

Service Guide

Keysight N5264B PNA-X Measurement Receiver

Notices

© Keysight Technologies, Inc.
2008-2022

No part of this manual may be reproduced in any form or by any means (including electronic storage and retrieval or translation into a foreign language) without prior agreement and written consent from Keysight Technologies, Inc. as governed by United States and international copyright laws.

Trademark Acknowledgments

Manual Part Number

N5264-90026

Edition

Edition 1, January 2022

Printed in USA/Malaysia

Published by:

Keysight Technologies
1400 Fountaingrove Parkway
Santa Rosa, CA 95403

Warranty

THE MATERIAL CONTAINED IN THIS DOCUMENT IS PROVIDED "AS IS," AND IS SUBJECT TO BEING CHANGED, WITHOUT NOTICE, IN FUTURE EDITIONS. FURTHER, TO THE MAXIMUM EXTENT PERMITTED BY APPLICABLE LAW, KEYSIGHT DISCLAIMS ALL WARRANTIES, EITHER EXPRESS OR IMPLIED WITH REGARD TO THIS MANUAL AND ANY INFORMATION CONTAINED HEREIN, INCLUDING BUT NOT LIMITED TO THE IMPLIED WARRANTIES OF MERCHANTABILITY AND FITNESS FOR A PARTICULAR PURPOSE. KEYSIGHT SHALL NOT BE LIABLE FOR ERRORS OR FOR INCIDENTAL OR CONSEQUENTIAL DAMAGES IN CONNECTION WITH THE FURNISHING, USE, OR PERFORMANCE OF THIS DOCUMENT OR ANY INFORMATION CONTAINED HEREIN. SHOULD KEYSIGHT AND THE USER HAVE A SEPARATE WRITTEN AGREEMENT WITH WARRANTY TERMS COVERING THE MATERIAL IN THIS

DOCUMENT THAT CONFLICT WITH THESE TERMS, THE WARRANTY TERMS IN THE SEPARATE AGREEMENT WILL CONTROL.

Technology Licenses

The hardware and/or software described in this document are furnished under a license and may be used or copied only in accordance with the terms of such license.

U.S. Government Rights

The Software is "commercial computer software," as defined by Federal Acquisition Regulation ("FAR") 2.101. Pursuant to FAR 12.212 and 27.405-3 and Department of Defense FAR Supplement ("DFARS") 227.7202, the U.S. government acquires commercial computer software under the same terms by which the software is customarily provided to the public.

Accordingly, Keysight provides the Software to U.S. government customers under its standard commercial license, which is embodied in its End User License Agreement (EULA), a copy of which can be found at

<http://www.keysight.com/find/sweula>

The license set forth in the EULA represents the exclusive authority by which the U.S. government may use, modify, distribute, or disclose the Software. The EULA and the license set forth therein, does not require or permit, among other things, that Keysight: (1) Furnish technical information related to commercial computer software or commercial computer software documentation that is not customarily provided to the public; or (2) Relinquish to, or otherwise provide, the government rights in excess of these rights customarily provided to the public to use, modify, reproduce, release, perform, display, or disclose commercial computer software or commercial computer software documentation. No additional

government requirements beyond those set forth in the EULA shall apply, except to the extent that those terms, rights, or licenses are explicitly required from all providers of commercial computer software pursuant to the FAR and the DFARS and are set forth specifically in writing elsewhere in the EULA. Keysight shall be under no obligation to update, revise or otherwise modify the Software. With respect to any technical data as defined by FAR 2.101, pursuant to FAR 12.211 and 27.404.2 and DFARS 227.7102, the U.S. government acquires no greater than Limited Rights as defined in FAR 27.401 or DFAR 227.7103-5 (c), as applicable in any technical data.

Safety Notices

CAUTION

A **CAUTION** notice denotes a hazard. It calls attention to an operating procedure, practice, or the like that, if not correctly performed or adhered to, could result in damage to the product or loss of important data. Do not proceed beyond a CAUTION notice until the indicated conditions are fully understood and met.

WARNING

A **WARNING** notice denotes a hazard. It calls attention to an operating procedure, practice, or the like that, if not correctly performed or adhered to, could result in personal injury or death. Do not proceed beyond a WARNING notice until the indicated conditions are fully understood and met.

1. Safety and Regulatory Information

Information in This Chapter 1-1
 Chapter One at-a-Glance 1-1
 Safety Symbols 1-2
 General Safety Considerations 1-3
 Safety Earth Ground 1-3
 Before Applying Power 1-3
 Servicing 1-5
 Electrostatic Discharge Protection 1-7
 Regulatory Information 1-9
 Instrument Markings 1-9
 Lithium Battery Disposal 1-11

2. General Product Information

Information in This Chapter 2-1
 Chapter Two at-a-Glance 2-1
 Maintenance 2-2
 Physical Maintenance 2-2
 Electrical Maintenance 2-2
 Analyzer Options and Accessories Available 2-3
 Pulse I/O Adapter-N1966A 2-3
 Upgrades Available 2-4
 Required Service Test Equipment 2-5
 Keysight Support, Services, and Assistance 2-8
 Service and Support Options 2-8
 Contacting Keysight 2-8
 Shipping Your Instrument to Keysight for Service or Repair 2-9

3. Tests and Adjustments

Information in This Chapter 3-1
 Conventions Used for Hardkeys, Softkeys, and Menu Items 3-1
 Chapter Three at-a-Glance 3-2
 Before You Begin 3-2
 Verify the Operating Environment 3-2
 Protect Against Electrostatic Discharge (ESD) 3-3
 Allow the Analyzer to Warm Up 3-3
 Review the Principles of Connector Care 3-3
 Adjustments 3-5
 Touchscreen Adjustment and Verification 3-5
 10 MHz Frequency Reference Adjustment (<6021 S/N Prefixes Only) 3-6

Contents

Synthesizer Bandwidth Adjustment (Option 108)	3-7
EE Default Adjustment (Option 108)	3-7
4. Troubleshooting	
Information in This Chapter	4-1
Chapter Four at-a-Glance	4-2
Conventions Used for Hardkeys, Softkeys, and Menu Items	4-2
Operating the Analyzer With Covers Removed	4-3
Protect Against Electrostatic Discharge (ESD)	4-4
Assembly Replacement Sequence	4-5
Getting Started with Troubleshooting	4-6
Check the Basics	4-6
Troubleshooting Organization	4-6
Power Up Troubleshooting	4-8
Power Supply Check	4-9
Troubleshooting LCD Display Problems	4-14
Front Panel Troubleshooting	4-16
Front Panel Keypad and RPG Test	4-16
A3 Display Test	4-19
Checking the A2 USB Board	4-20
A1 Front Panel Interface Board	4-21
Rear Panel Troubleshooting	4-23
Checking the USB Ports	4-23
Checking the CONTROLLER Port	4-23
LAN Troubleshooting	4-24
Instrument Block Diagram	4-30
N5264B PNA-X Measurement Receiver	4-30
5. Theory of Operation	
Information in This Chapter	5-1
Chapter Five at-a-Glance	5-1
Measurement Receiver System Operation	5-2
Functional Groups of the Measurement Receiver	5-2
Synthesized LO Group Operation (Option 108)	5-4
Basic Operation	5-4
A10 Frequency Reference Board	5-6
A11 13.5 GHz LO Synthesizer Board (Option 108)	5-7
A21 Multiplier/Amplifier 26.5 Board (HMA26.5) (Option 108)	5-7
A19 Test Set Motherboard	5-7
IF Multiplexer Group Operation	5-12

Rear Panel IF Inputs	5-12
A20 IF Multiplexer Board	5-12
Digital Processing and Digital Control Group Operation	5-14
Front Panel Subgroup	5-16
Data Acquisition and Processing Subgroup	5-17
Power Supply Group Operation	5-19
6. Replaceable Parts	
Information in This Chapter	6-1
Chapter Six at-a-Glance	6-1
Ordering Information	6-2
Assembly Fault Identification and Replacement Sequence	6-3
Replaceable Parts Listings	6-4
Front Panel Assembly, Front Side, All Options	6-6
Front Panel Assembly, Back Side, All Options.	6-7
Top Assemblies, All Options.	6-12
Top Cables, All Options	6-16
Bottom Assemblies, All Options.	6-18
Bottom Cables, All Options	6-20
Top Hardware and Miscellaneous Parts, All Options.	6-22
Bottom Hardware and Miscellaneous Parts, All Options.	6-24
Internal Hardware and Miscellaneous Parts, All Options	6-26
External Hardware and Miscellaneous Parts, All Options	6-28
Rear Panel Assembly, All Options	6-30
Miscellaneous Part Numbers	6-32
7. Repair and Replacement Procedures	
Information in This Chapter	7-1
Chapter Seven at-a-Glance	7-1
Personal Safety Warnings	7-2
Electrostatic Discharge (ESD) Protection.	7-3
Removal and Replacement Procedures.	7-4
Removing the Covers	7-5
Removing and Replacing the Front Panel Assembly.	7-7
Removing and Replacing the A1–A3 and Other Front Panel Subassemblies.	7-9
Removing and Replacing the A10, A11, and A12 Boards (For analyzers with serial numbers prefixed MY/SG/US5144 and below.)	7-17
Removing and Replacing the A10, A11, and A12 Boards (For analyzers with serial numbers prefixed MY/SG/US5204 and above.)	7-19
Removing and Replacing the A14 System Motherboard.	7-21

Contents

Removing and Replacing the A15 Midplane Board	7-24
Removing and Replacing the A16 Power Supply Assembly	7-26
Removing and Replacing the A17 CPU Board Assembly	7-28
Removing and Replacing the A18 GPIB Board	7-30
Removing and Replacing the A19 Test Set Motherboard	7-32
Removing and Replacing the A20 IF Multiplexer Board	7-35
Removing and Replacing the A21 HMA26.5	7-37
Removing and Replacing the A51 Solid State Drive (SSD)	7-39
Removing and Replacing the Rear Panel	7-41
Removing and Replacing the Fans	7-43
Removing and Replacing the Lithium Battery	7-45
Post-Repair Procedures	7-47
8. General Purpose Maintenance Procedures	
Information in This Chapter	8-1
Chapter Eight at-a-Glance	8-1
Conventions Used for Hardkeys, Softkeys, and Menu Items	8-1
Keysight License Manager	8-2
Accessing the Keysight License Manager	8-2
Software Entitlement Certificate	8-2
Enabling or Removing Options	8-3
Repairing and Recovering Option Data	8-3
Installing or Changing a Serial Number	8-3
Firmware Upgrades	8-4
How to Check the Current Firmware Version	8-4
Downloading from the Internet	8-4
Operating System Recovery	8-5
Recovering from Hard Disk Drive Problems	8-5

1 Safety and Regulatory Information

Information in This Chapter

This chapter provides safety information that will help protect you and your network analyzer. It also contains information that is required by various government regulatory agencies.

Chapter One at-a-Glance

Section Title	Summary of Content	Start Page
Safety Symbols	Descriptions of CAUTION and WARNING symbols used throughout this manual.	page 1-2
General Safety Considerations	A list of safety points to consider when servicing your network analyzer.	page 1-3
Electrostatic Discharge Protection	A discussion of electrostatic discharge (ESD) and related recommendations and requirements for ESD protection.	page 1-7
Regulatory Information	Definitions of instrument markings. Instructions for disposing of the analyzer's lithium battery.	page 1-9

Safety Symbols

The following safety symbols are used throughout this manual. Familiarize yourself with each of the symbols and its meaning before operating this instrument.

CAUTION

Caution denotes a hazard. It calls attention to a procedure that, if not correctly performed or adhered to, could result in damage to or destruction of the instrument. Do not proceed beyond a caution note until the indicated conditions are fully understood and met.

WARNING

Warning denotes a hazard. It calls attention to a procedure which, if not correctly performed or adhered to, could result in injury or loss of life. Do not proceed beyond a warning note until the indicated conditions are fully understood and met.

General Safety Considerations

Safety Earth Ground

WARNING

This is a Safety Class I product (provided with a protective earthing ground incorporated in the power cord). The mains plug shall only be inserted in a socket outlet provided with a protective earth contact. Any interruption of the protective conductor, inside or outside of the instrument, will make the instrument dangerous. Intentional interruption is prohibited.

CAUTION

Always use the three-prong AC power cord supplied with this product. Failure to ensure adequate grounding by not using this cord may cause product damage.

Before Applying Power

WARNING

If this product is not used as specified, the protection provided by the equipment could be impaired. This product must be used in a normal condition (in which all means for protection are intact) only.

WARNING

If an instrument handle is damaged, you should replace it immediately. Damaged handles can break while you are moving or lifting the instrument and cause personal injury or damage to the instrument.

CAUTION

This instrument has autoranging line voltage input. Be sure the supply voltage is within the specified range.

WARNING

Supply voltages which oscillate between the two normal input ranges of the autoranging line voltage input will damage the power supply. In rare cases, this damage has become a user safety concern. If unstable power levels are expected, the analyzer input power must be buffered by a line conditioner.

CAUTION

This product is designed for use in Installation Category II and Pollution Degree 2.

CAUTION

Do not operate the analyzer with the outer cover removed for more than 30 minutes, as this could cause the analyzer to overheat which could result in costly damage.

CAUTION

Ventilation Requirements: When installing the product in a cabinet, the convection into and out of the product must not be restricted. The ambient temperature (outside the cabinet) must be less than the maximum operating temperature of the instrument by 4 °C for every 100 watts dissipated in the cabinet. If the total power dissipated in the cabinet is greater than 800 watts, then forced convection must be used.

CAUTION

The measuring terminals on this instrument are designed to be used with external signals described in Measurement Category I, but NOT with external signals described in Categories II, III, and IV. The input of this instrument cannot be connected to the mains.

Servicing

WARNING

These servicing instructions are for use by qualified personnel only. To avoid electrical shock, do not perform any servicing unless you are qualified to do so.

WARNING

Danger of explosion if battery is incorrectly replaced. Replace only with the same or equivalent type recommended. Discard used batteries according to local ordinances and/or manufacturer's instructions.

WARNING

Procedures described in this document may be performed with power supplied to the product while protective covers are removed. Energy available at many points may, if contacted, result in personal injury.

CAUTION

Do not operate the analyzer with the outer cover removed for more than 30 minutes, as this could cause the analyzer to overheat which could result in costly damage.

WARNING

No operator serviceable parts inside. Refer servicing to qualified personnel. To prevent electrical shock, do not remove covers.

WARNING

The opening of covers or removal of parts may expose dangerous voltages. Disconnect the instrument from all voltage sources while it is being opened.

WARNING

The detachable power cord is the instrument disconnecting device. It disconnects the mains circuits from the mains supply before other parts of the instrument. The front panel switch is only a standby switch and is not a LINE switch (disconnecting device).

NOTE

There are no replaceable fuses in the mains input or within the power supply assembly.

NOTE

Keysight personnel: after calibration is completed, attach four "calibration void if seal broken" stickers to the PNA as shown in [Figure 1-1](#).

Figure 1-1 Location of Calibration Stickers on PNA



Install 4x calibration stickers where shown below

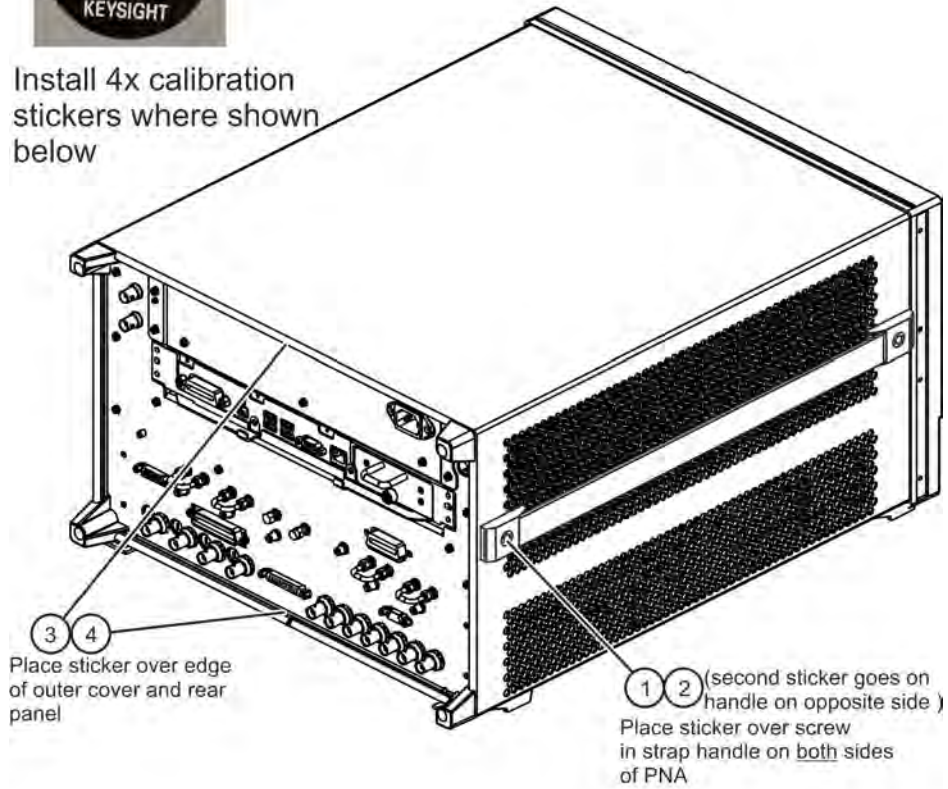

cal_void_sticker

Electrostatic Discharge Protection

Protection against electrostatic discharge (ESD) is essential while removing assemblies from or connecting cables to the network analyzer. Static electricity can build up on your body and can easily damage sensitive internal circuit elements when discharged. Static discharges too small to be felt can cause permanent damage. To prevent damage to the instrument:

- **always** have a grounded, conductive table mat in front of your test equipment.
- **always** wear a grounded wrist strap, connected to a grounded conductive table mat, having a 1 M Ω resistor in series with it, when handling components and assemblies or when making connections.
- **always** wear a heel strap when working in an area with a conductive floor. If you are uncertain about the conductivity of your floor, wear a heel strap.
- **always** ground yourself before you clean, inspect, or make a connection to a static-sensitive device or test port. You can, for example, grasp the grounded outer shell of the test port or cable connector briefly.
- **always** ground the center conductor of a test cable before making a connection to the analyzer test port or other static-sensitive device. This can be done as follows:
 1. Connect a short (from your calibration kit) to one end of the cable to short the center conductor to the outer conductor.
 2. While wearing a grounded wrist strap, grasp the outer shell of the cable connector.
 3. Connect the other end of the cable to the test port and remove the short from the cable.

Figure 1-2 shows a typical ESD protection setup using a grounded mat and wrist strap. Refer to **“ESD Supplies” on page 6-33** for part numbers.

Figure 1-2 ESD Protection Setup

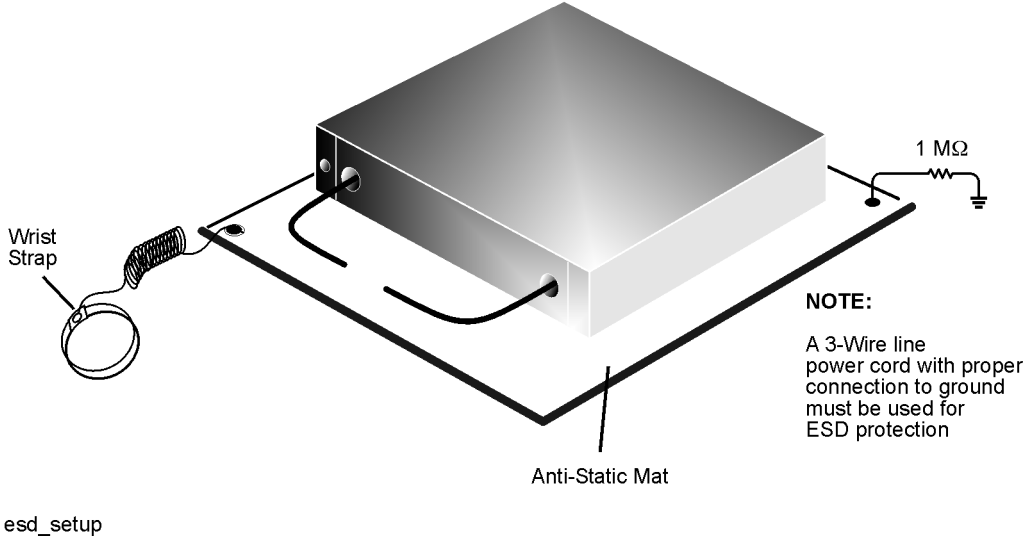

Regulatory Information











This section contains information that is required by various government regulatory agencies.

Instrument Markings



The table below lists the definitions of markings that may be on or with the product. Familiarize yourself with each marking and its meaning before operating the instrument.

NOTE

All labels and symbols may not appear on your instrument.

	This symbol marks the standby position of the power line switch.
	This symbol marks the ON position of the power line switch.
	This symbol marks the OFF position of the power line switch.
	This symbol indicates that the input power required is AC.
	This symbol indicates DC voltage
	This symbol indicates a three-phase alternating current.
	This symbol indicates Frame or chassis Terminal.
	The instruction documentation symbol. The product is marked with this symbol when it is necessary for the user to refer to the instruction in the documentation.
	This symbol indicate the presence of a Laser device.
	This symbol indicates the surface can be hot.
	This symbol indicated the product is sensitive to electrostatic discharge.

	This symbol identifies the Protective Conductor terminal.
	This symbol indicates the equipment is protected throughout by double or reinforced insulation.
	The CE mark is a registered trademark of the European Community (if accompanied by a year, it is the year when the design was proven). It indicates that the product complies with all the relevant directives.
	The UK conformity mark is a UK government owned mark. Products showing this mark comply with all applicable UK regulations.
	The Keysight email address is required by EU directives applicable to our product.
	The CSA mark is a registered trademark of the CSA International.
	Two person lift required.
CAN ICES/NMB-001(A)	Canada EMC label. Interference-Causing Equipment Standard for industrial, scientific and medical (ISM) equipment. Matériel industriel, scientifique et médical (ISM).
	CE/ICES/ISM label. (Old mark for reference only.) This is a space saver label that combines three markings - CE with CAN ICES and ISM (see above) and ISM (see below).
	This is a space saver label that combines three markings - CE with CAN ICES and ISM (see above) and ISM (see below).
	The RCM mark is a registered trademark of the Australian Communications and Media Authority.
	This is a space saver label that combines two markings - CAN ICES and ISM.
ISM 1-A	This is a symbol of an Industrial Scientific and Medical Group 1 Class A product (CISPR 11, Clause 5).
	South Korean Certification (KC) mark. It includes the marking's identifier code.

	The crossed-out wheeled bin symbol indicates that separate collection for waste electric and electronic equipment (WEEE) is required, as obligated by the EU DIRECTIVE and other National legislation. Please refer to www.keysight.com/go/takeback to understand your trade-in options with Keysight, in addition to product takeback instructions.
	China Restricted Substance Product Label. The EPUP (environmental protection use period) number in the center indicates the time period during which no hazardous or toxic substances or elements are expected to leak or deteriorate during normal use and generally reflects the expected useful life of the product.
	Universal recycling symbol. This symbol indicates compliance with the China standard GB 18455-2001 as required by the China RoHS regulations for paper/fiberboard packaging.
IP x y	This mark indicates product has been designed to meet the requirements of “IP x y”, where “x” is the solid particle protection and “y” is the liquid ingress protection.

Lithium Battery Disposal

If the battery on the A17 CPU board assembly needs to be disposed of, dispose of it in accordance with your country’s requirements. If required, you may return the battery to Keysight Technologies for disposal. Refer to **“Contacting Keysight” on page 2-8** for assistance.



**DO NOT THROW BATTERIES AWAY BUT
COLLECT AS SMALL CHEMICAL WASTE.**

For instructions on removing and replacing the battery on the A17 CPU board assembly, refer to **“Removing and Replacing the Lithium Battery” on page 7-45.**

Safety and Regulatory Information
Regulatory Information

2 General Product Information

Information in This Chapter

Chapter Two at-a-Glance

Section Title	Summary of Content	Start Page
Maintenance	Cleaning instructions for the external surfaces of your measurement receiver. Information about electrical maintenance of your measurement receiver.	page 2-2
Analyzer Options and Accessories Available	A hyperlink to the PNA Configuration Guide, which includes a list of options and accessories available for the microwave network analyzers.	page 2-3
Upgrades Available	A list of the upgrades available for your measurement receiver.	page 2-4
Required Service Test Equipment	A list of service equipment that is required to perform performance tests, adjustments, and troubleshooting.	page 2-5
Keysight Support, Services, and Assistance	The Internet address (URL) for on-line assistance. Service and support options available. Important information about shipping your measurement receiver to Keysight for service or repair.	page 2-8

Maintenance

Physical Maintenance

WARNING

To prevent electrical shock, disconnect the product from the mains source before cleaning. Use a dry cloth or one slightly dampened with water to clean the external case parts. Do not attempt to clean internally.

Electrical Maintenance

Refer to [“Review the Principles of Connector Care” on page 3-3.](#)

Analyzer Options and Accessories Available

To see a list of the options and accessories available for the network analyzers, including ordering information, refer to the Keysight PNA Family Microwave Network Analyzers Configuration Guide, available online at <https://www.keysight.com/us/en/assets/7018-05185/configuration-guides/5992-1465.pdf>.

Pulse I/O Adapter-N1966A

An adapter for connecting between the analyzer's rear-panel PULSE I/O connector and the coaxial inputs and outputs of external pulse generators and external pulse modulators. The adapter contains 11 SMB-male coaxial connectors and a mating connector for the rear-panel PULSE I/O connector.

This adapter can be ordered as model number N1966A.

Figure 2-1 Pulse I/O Adapter



N5242_001_201

Upgrades Available

The options described in this section can be ordered as upgrades. To order an upgrade for your measurement receiver, order the product's model number, followed by a "U", then indicate the option to be added:

- Your product's current model number followed by a "U". For example, N5264BU.
- The number of the desired option from the available list. For example, Time Domain option would be N5264BU-010.

Individual upgrade kits are also available and can be ordered by part number. Refer to **"Miscellaneous Part Numbers" on page 6-32** for a complete list of available kits.

The following table lists the upgrades that are available for your measurement receiver. Refer to the previous section, **"Analyzer Options and Accessories Available" on page 2-3**, for a complete description of each option upgrade.

Table 2-1 Upgrades Available

Upgrade	Order Number
Time Domain (Option 010)	N5264BU-010
LO Source (Option 108)	N5264BU-108
Fast CW Mode (Option 118)	N5264BU-118

Required Service Test Equipment

Equipment	Critical Specifications	Recommended Model or Part Number	Alternate Model or Part Number	Use ^a
Test Instruments and Software				
Frequency counter	Freq: 10 MHz to 10.5 GHz Accuracy : ±0.5 ppm	53151A Opt 001	None	P, A, T
Spectrum analyzer	Min Freq: 1 MHz Max Freq: > 4 GHz Resolution BW: 300 Hz	8565E	856xE	A, T
Signal generator	CW Freq: 1.185 GHz	N5181A, Option 503	E8257D, Option 520	P, A, T
Power meter	Accuracy: ±0.0068 dB	N1913A/14A	E4418A/B, E4419A/B ^b	P, A, T
Power sensor	Freq: 300 kHz to 3.0 GHz Range: -30 to +20 dBm	N8482A	8482A	P, A, T
Power sensor	Freq: 3.0 GHz to 26.5 GHz Range: -30 to +20 dBm	N8485A	U8485A	P, A, T
Dynamic accuracy test set	None specified	U3020AD01	None	P
Digital multi-meter	Voltage and resistance measurement capability Voltage resolution: 10 mV	Any	Any	T
Printer	N/A	Any printer with Microsoft Windows XP or Windows 7 driver		P
Internal test software ^c	N/A	Option 897/898	None	P

- a. P = Performance tests, A = Adjustments, T = Troubleshooting, V = System verification
b. If an accurate measurement of the dynamic accuracy specification is not required, the E4418A or E4419A can be used.
c. The recommended model or part number for all equipment listed with a "P" in the Use column is required for proper operation of the measurement receiver's internal test software.

Required Service Test Equipment (Cont'd)

Equipment ^a	Critical Specifications	Recommended Model or Part Number	Alternate Model or Part Number	Use ^b
Calibration and Verification Kits				
3.5 mm calibration kit	Freq: 10 MHz to 26.5 GHz	85052B	85052D	P,T,V

General Product Information
Required Service Test Equipment

Equipment ^a	Critical Specifications	Recommended Model or Part Number	Alternate Model or Part Number	Use ^b
3.5 mm verification kit	Freq: 10 MHz to 26.5 GHz	85053B	None	V
Cables				
BNC cable (2 required)	50 Ω , length \geq 60 cm	8120-1839	None	A
3.5 mm RF cable (Qty 2)	50 Ω , length \geq 60 cm	85131C	85131E	P,A,V
GPIB cable	N/A	10833A/B/C/D	None	P,A
Adapters				
3.5 mm (f) to 3.5 mm (f)	Return Loss: \geq 32 dB	83059B	85052-60012 ^c	P,A,T
3.5 mm (f) to type-N (m)	Return Loss: \geq 28 dB	1250-1743	None	P,A,T
Attenuators				
3.5 mm (m,f), 10-dB fixed attenuator	Accuracy: \pm 0.5 dB Freq: 10 MHz to 26.5 GHz	8493C Option 010	None	P
3.5 mm (m,f), 20-dB fixed attenuator	Accuracy: \pm 0.5 dB Freq: 10 MHz to 26.5 GHz	8493C Option 020	None	P

- a. Unless specified otherwise, equipment listed is required for all measurement receiver options.
b. P = Performance tests, A = Adjustments, T = Troubleshooting, R = Repair, V = System verification
c. Included in the 85052B/D calibration kits.

Required Service Test Equipment (Cont'd)

Equipment ^a	Critical Specifications	Recommended Model or Part Number	Alternate Model Number	Use ^b
Tools				
T-8 TORX driver	0.6 N-m (5 in-lb) setting	N/A	N/A	R
T-10 TORX driver	0.5, 0.8, and 1.0 N-m (4, 7, and 9 in-lb) settings	N/A	N/A	T, R
T-15 TORX driver	1.5 N-m (14 in-lb) setting	N/A	N/A	T, R
T-20 TORX driver	2.4 N-m (21 in-lb) setting	N/A	N/A	T, R
1/4 inch and 5/16 inch open-end wrench	Thin profile	8710-0510	N/A	A, R
5/16 inch, open-end torque wrench (metric equivalent is 8 mm)	1.1 and 2.4 N-m (10 and 21 in-lb) settings (for semi-rigid cables)	N/A	N/A	T, R

General Product Information
Required Service Test Equipment

Equipment ^a	Critical Specifications	Recommended Model or Part Number	Alternate Model Number	Use ^b
1 inch, open-end torque wrench (metric equivalent is 26 mm)	8.1 N-m (72 in-lb) setting (for Port 1 and Port 2 connector nuts)	N/A	N/A	R
20 mm, open-end torque wrench	0.9 N-m (8 in-lb) setting (for measurement port connections)	8710-1764	N/A	P, A, T
Static Safety Parts				
Adjustable antistatic wrist strap	N/A	9300-1367	None	P, A, T
Antistatic wrist strap grounding cord (5 foot)	N/A	9300-0980	None	P, A, T
Static control table mat and earth ground wire	N/A	9300-0797	None	P, A, T
Miscellaneous				
USB flash ROM drive	N/A	Any	None	P, A, R

a. Unless specified otherwise, equipment listed is required for all measurement receiver options.

b. P = Performance tests, A = Adjustments, T = Troubleshooting, R = Repair, V = System verification

Keysight Support, Services, and Assistance

Information on the following topics is included in this section.

- “Service and Support Options”
- “Contacting Keysight”
- “Shipping Your Instrument to Keysight for Service or Repair”

Service and Support Options

The analyzer’s standard warranty period is one-year from the time of initial delivery. All repairs require the analyzer to be shipped to the nearest Keysight Technologies service center. Extended warranty periods can be purchased with the initial product purchase.

There are many other repair and calibration options available from the Keysight Technologies support organization. These options cover a range of service agreements with a variety of time frames. The following support products with their associated options are available for purchase with the initial product purchase.

- R1280A Return to Keysight Warranty and Service Plan
Options are available to extend the warranty period to five years.
- R1288A Return to Keysight On-Site Warranty and Service Plan
Same as R1280A, but the service is provided at the customer site.

For more information on these and other service, please visit <https://www.keysight.com/us/en/support/N5231B/pna-l-microwave-network-analyzer-13-5-ghz.html> or <https://www.keysight.com/us/en/product/N5232B/pna-l-microwave-network-analyzer-20-ghz.html> or refer to “Contacting Keysight” on page 2-8. If the warranty or calibration plan period has expired, these services are available on a per-incident basis. Visit this InfoLine web site or contact Keysight to obtain a quote.

Contacting Keysight

Assistance with test and measurements needs and information or finding a local Keysight office are available on the Web at:
<http://www.keysight.com/find/assist>

If you do not have access to the Internet, please contact your Keysight field engineer.

NOTE

In any correspondence or telephone conversation, refer to the Keysight product by its model number and full serial number. With this information, the Keysight representative can determine whether your product is still within its warranty period.

Shipping Your Instrument to Keysight for Service or Repair

NOTE

Keysight Technologies reserves the right to reformat or replace the internal solid state drive in your measurement receiver as part of its repair. This will erase all user information stored on the solid state drive. It is imperative, therefore, that you make a backup copy of your critical test data located on the solid state drive before shipping the measurement receiver to Keysight for repair.

If you wish to send your instrument to Keysight Technologies for service or repair:

- Include a complete description of the service requested or of the failure and a description of any failed test and any error message.
- Ship the instrument using the original or comparable antistatic packaging materials.
- Contact Keysight for instructions on where to ship your instrument.

General Product Information
Keysight Support, Services, and Assistance

3 Tests and Adjustments

Information in This Chapter

This chapter contains procedures to help you check, verify, and adjust your PNA.

- The checks verify the operation of the assemblies in your analyzer.
- The verification compares the operation of your analyzer to a gold standard.
- The adjustments allow you to tune your analyzer for maximum response.

Conventions Used for Hardkeys, Softkeys, and Menu Items

The following conventions are used in this document:

Hardkey

This represents a “hardkey”, a key that is physically located on the instrument.

[Tab]

This represents a “tab”, whose label is determined by the instrument firmware.

Softkey

This represents a “softkey”, a key whose label is determined by the instrument firmware.

Menu Item

This represents an item in a drop-down or pop-up menu.

Chapter Three at-a-Glance

Section Title	Summary of Content	Start Page
Before You Begin	Items to consider or procedures to perform before testing is begun: <ul style="list-style-type: none">– Verify the Operating Environment– Protect Against Electrostatic Discharge (ESD)– Allow the Analyzer to Warm Up	page 3-2
Adjustments	Setups and procedures for adjusting your analyzer: <ul style="list-style-type: none">– Touchscreen Adjustment and Verification– 10 MHz Frequency Reference Adjustment (<6021 S/N Prefixes Only)– Synthesizer Bandwidth Adjustment (Option 108)– EE Default Adjustment (Option 108)	page 3-5

Before You Begin

Before checking or adjusting the analyzer, refer to the following paragraphs to:

- make sure the operating environment is within its requirements
- make sure that proper electrostatic discharge (ESD) protection is provided
- make sure the analyzer has warmed up properly to achieve system stability

NOTE

Keysight personnel: see Figure 1-1 on page 1-6 to review where the calibration stickers should be placed on the PNA.

Verify the Operating Environment

Due to their operating specifications, the verification and calibration kit devices determine your operating environment conditions. Open the calibration and verification kits and place all the devices on top of the foam inserts so they will reach room temperature. As the device dimensions change with temperature, their electrical characteristics change as well.

It is necessary to keep the environmental levels within the following limits:

- Temperature: $+23\text{ °C} \pm 3\text{ °C}$ (Error-corrected temperature range)

Once the measurement calibration has been done, the ambient temperature must be maintained to within $\pm 1\text{ °C}$ of the calibration temperature.

- Humidity: 0% to 95% at 40 °C maximum, non-condensing

- Altitude: 0 to 4,600 meters (^a15,000 feet.)

Protect Against Electrostatic Discharge (ESD)

This is important. If not properly protected against, electrostatic discharge can seriously damage your analyzer, resulting in costly repair.

CAUTION

To reduce the chance of electrostatic discharge, follow all of the recommendations outlined in “**Electrostatic Discharge Protection**” on page 1-7, for all of the procedures in this chapter.

Allow the Analyzer to Warm Up

NOTE

To achieve the maximum system stability, allow the analyzer to warm up for at least 90 minutes.

Review the Principles of Connector Care

Proper connector care and connection techniques are critical for accurate and repeatable measurements. Refer to **Table 3-1** for tips on connector care.

Prior to making connections to your analyzer, carefully review the information about inspecting, cleaning, and gaging connectors. Refer to the calibration kit documentation for detailed connector care information.

For course numbers about additional connector care instruction, contact Keysight Technologies. Refer to “**Contacting Keysight**” on page 2-8.

Table 3-1 Connector Care Quick Reference Guide

Handling and Storage			
Do	– Keep connectors clean	Do Not	– Touch mating-plane surfaces
	– Extend sleeve or connector nut		– Set connectors contact-end down
	– Use plastic end-caps during storage		– Store connectors or adapters loose
Visual Inspection			
Do	– Inspect all connectors carefully	Do Not	– Use a damaged connector - ever
	– Look for metal particles, scratches, and dents		
Connector Cleaning			
Do	– Try compressed air first	Do Not	– Use any abrasives
	– Use isopropyl alcohol ^a		• Get liquid into plastic support beads
	– Clean connector threads		
Gaging Connectors			

Table 3-1 Connector Care Quick Reference Guide

Do	<ul style="list-style-type: none"> – Clean and zero the gage before use – Use the correct gage type – Use correct end of calibration block – Gage all connectors before first use 	Do Not	<ul style="list-style-type: none"> – Use an out-of-specification connector
Making Connections			
Do	<ul style="list-style-type: none"> – Align connectors carefully – Make preliminary connection contact lightly – Turn only the connector nut – Use a torque wrench for final connection 	Do Not	<ul style="list-style-type: none"> – Apply bending force to connection – Over tighten preliminary connection – Twist or screw any connection – Tighten past torque wrench “break” point
<p>a. Cleaning connectors with alcohol shall only be done with the instrument’s power cord removed, and in a well-ventilated area. Allow all residual alcohol moisture to evaporate, and the fumes to dissipate prior to energizing the instrument.</p>			

Adjustments

Adjustments are firmware-driven tests that are used to fine-tune your analyzer. The 10 MHz Frequency Reference Adjustment is applicable to the standard N5264B and the Synthesizer BW Adjustment and EE Default Adjustment are applicable for the N5264B Option 108.

- [“Touchscreen Adjustment and Verification” on page 3-5](#)
- [“10 MHz Frequency Reference Adjustment \(<6021 S/N Prefixes Only\)” on page 3-6](#)
- [“Synthesizer Bandwidth Adjustment \(Option 108\)” on page 3-7](#)
- [“EE Default Adjustment \(Option 108\)” on page 3-7](#)

Touchscreen Adjustment and Verification

NOTE

For best results, use a touchscreen soft touch pen for the following adjustments.

The touchscreen adjustment (calibration) is used to correct the touchscreen accuracy when you replace your front panel, or your SSD. Refer to [“Calibration Procedure”](#).

The touchscreen verification can be run to verify the touchscreen has been correctly calibrated. Refer to [“Verification Procedure” on page 3-6](#).

Calibration Procedure

NOTE

If your touchscreen is not behaving as expected, you can reset your display using the Table PC Setting window and re-calibrate the touch settings using the [“Calibration Procedure”](#) below.

- Step 1.** Verify your instrument is powered up.
- Step 2.** Press **Instrument** > **Display** > **Display Setup** > **Calibrate Touchscreen...**
- Step 3.** In the Table PC Setting window that opens, press **Calibrate...**
- Step 4.** When the User Account Control opens, press **Yes**.
- Step 5.** After pressing all of the cross hair calibration points a Digitizer Calibration Tool window opens, press **Yes**.
- Step 6.** In the Tablet PC Settings window, press **OK**.

Verification Procedure

NOTE

If your display fails the verification process, you can reset your display using the Table PC Setting window. Refer to [“Calibration Procedure” on page 3-5](#).

- Step 1.** Verify your instrument is powered up.
- Step 2.** Press **System** > **Service** > **Display...** > **Display Setup** > **Calibrate Touchscreen...**
- Step 3.** In the Table PC Setting window that opens, press **Calibrate...**
- Step 4.** Follow the instrument’s display prompts.

10 MHz Frequency Reference Adjustment (<6021 S/N Prefixes Only)

The 10 MHz frequency adjustment is used to adjust the frequency accuracy of the network analyzer’s 10 MHz frequency reference on the A10 frequency reference board assembly.

Equipment Used for the 10 MHz Frequency Reference Adjustment

Equipment Type	Model or Part Number	Alternate Model or Part Number
Cable, BNC, 50Ω, 24 inch	8120-1839	Any
Frequency counter	53151A, Option 001	Any that will measure a signal at 10 MHz.

Procedure

NOTE

This adjustment typically adjusts to within ± 0.01 ppm.

1. Connect the equipment as shown in [Figure 3-1](#). Connect a GPIB cable between the network analyzer and the frequency counter.

Figure 3-1 Equipment Setup for the 10 MHz Frequency Reference Adjustment

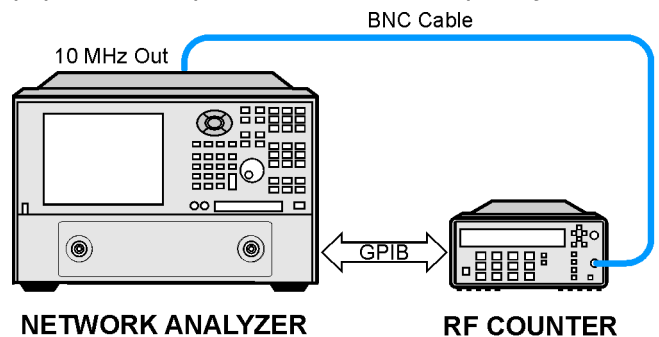

st511a

2. Press UTILITY **System**, then **Service**, then **Adjustment Routines**, then click 10 MHz Freq Adjustment.
3. Ensure the GPIB settings are correct.
4. Follow the instructions and prompts as they are displayed.

Synthesizer Bandwidth Adjustment (Option 108)

This adjusts the bandwidth of the 13.5 GHz synthesizers.

Procedure

1. Press UTILITY **System**, then **Service**, then **Adjustment Routines**, then click Synthesizer Bandwidth Adj.
2. Follow the instructions and prompts as they are displayed.

EE Default Adjustment (Option 108)

This sets the EEPROM data to their default values.

Procedure

1. Press UTILITY **System**, then **Service**, then **Adjustment Routines**, then click EE Default Adjustment.
2. On the dialog box, select Initialize rather than Adjust/Verify because an adjustment is typically unnecessary.
3. Follow the instructions and prompts as they are displayed.

Tests and Adjustments
Adjustments

4 Troubleshooting

Information in This Chapter

The information in this chapter helps you:

- Identify the portion of the analyzer at fault.
- Locate the specific troubleshooting procedure to identify the assembly or peripheral at fault.

The sections in this chapter are arranged in a logical troubleshooting order. The following table lists the sections and a brief summary of what to look for in that section.

Chapter Four at-a-Glance

Section Title	Summary of Content	Start Page
Getting Started with Troubleshooting	A starting point for troubleshooting.	page 4-6
Power Up Troubleshooting	Power-up problems: <ul style="list-style-type: none">– Power supply problems– LCD problems– Bootup for the network analyzer interface	page 4-8
Front Panel Troubleshooting	Problems occurring after the network analyzer interface is loaded: <ul style="list-style-type: none">– Does the display color appear correct?– Do the front panel keys function properly?– Does the front panel USB connector function properly?	page 4-16
Rear Panel Troubleshooting	Problems associated with the rear panel interconnects. The data found at these rear panel interconnects can be used to troubleshoot the CPU board.	page 4-23
Instrument Block Diagram	A block diagram for the analyzer including all options.	page 4-30

Conventions Used for Hardkeys, Softkeys, and Menu Items

The following conventions are used in this document:

Hardkey

This represents a “hardkey”, a key that is physically located on the instrument.

Tab

This represents a “tab”, whose label is determined by the instrument firmware.

Softkey

This represents a “softkey”, a key whose label is determined by the instrument firmware.

Menu Item

This represents an item in a drop-down or pop-up menu.

Operating the Analyzer With Covers Removed

CAUTION

Do not operate the analyzer with the outer cover removed for more than 30 minutes, as this could cause the analyzer to overheat which could result in costly damage.

Protect Against Electrostatic Discharge (ESD)

This is important. If not properly protected against, electrostatic discharge can seriously damage your analyzer, resulting in costly repair.

CAUTION

To reduce the chance of electrostatic discharge, follow all of the recommendations outlined in **“Electrostatic Discharge Protection”** on **page 1-7**, for all of the procedures in this chapter.

Assembly Replacement Sequence

After identifying the problem requiring an assembly to be replaced, follow these steps:

- Step 1.** Order a replacement assembly. Refer to [Chapter 6, “Replaceable Parts.”](#)
- Step 2.** Replace the faulty assembly and determine what adjustments are necessary. Refer to [Chapter 7, “Repair and Replacement Procedures.”](#)
- Step 3.** Perform the necessary adjustments. Refer to [Chapter 3, “Tests and Adjustments.”](#)
- Step 4.** Perform the necessary performance tests. Refer to [Chapter 3, “Tests and Adjustments.”](#)

Getting Started with Troubleshooting

Where you begin troubleshooting depends upon the symptoms of the failure. Start by checking the basics as outlined in the following section. Also review the flowchart in **Figure 4-1 on page 4-7**. You should then be able to determine where in the troubleshooting procedure to begin, to locate the failed assembly.

Check the Basics

A problem can often be solved by repeating the procedure you were following when the problem occurred. Before calling Keysight Technologies or returning the instrument for service, please perform the following checks:

1. Is there power at the mains receptacle? If not, correct this situation and proceed.
2. Is the instrument turned on? Check to see if the front panel line switch glows. This indicates the power supply is on. If the front panel line switch is on but the power supply does not appear to be on, go to **“Power Up Troubleshooting” on page 4-8**.
3. Is the Windows® operating system running? If not, refer to **“Operating System Recovery” in Chapter 8** for instructions.
4. If other equipment, cables, and connectors are being used with the instrument, make sure they are clean, connected properly and operating correctly.
5. Review the procedure for the measurement being performed when the problem appeared. Are all the settings correct? If not, correct them.
6. If the instrument is not functioning as expected, return the unit to a known state by pressing the UTILITY **Preset** key.
7. Is the measurement being performed, and the results that are expected, within the specifications and capabilities of the instrument? Refer to the embedded help in the analyzer for instrument specifications.
8. If the problem is thought to be due to firmware, check to see if the instrument has the latest firmware before starting the troubleshooting procedure. Refer to **“Firmware Upgrades” in Chapter 8** for instructions.
9. If the necessary test equipment is available, perform the operator’s check and system verification in **Chapter 3, “Tests and Adjustments.”**

Troubleshooting Organization

Follow the flowgraph in **Figure 4-1** to help direct you to the correct section for troubleshooting the analyzer.

Figure 4-1 Troubleshooting Organization Flowchart

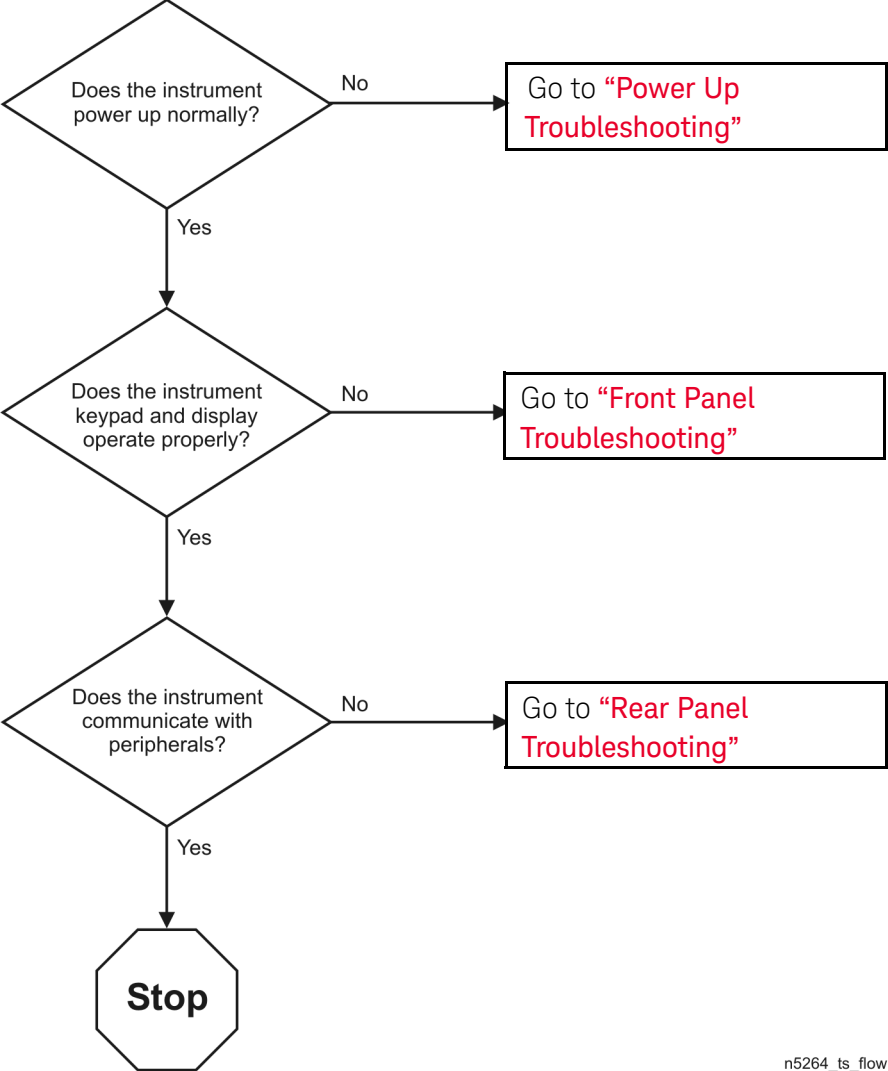

n5264_ts_flow

Power Up Troubleshooting

WARNING

Immediately unplug the instrument from the ac power line if the unit shows any of the following symptoms:

- Smoke, arcing, or unusual noise from inside the analyzer.
 - A circuit breaker or fuse on the main ac power line opens.
-

Check your network analyzer for evidence that it is powering up correctly. Perform the following steps and make sure that the analyzer is displaying correct behavior as noted in the following steps.

- Step 1.** Disconnect all peripherals and plug in the network analyzer. Before the analyzer is powered on, the line switch should glow yellow and no other lights should be on.
- Step 2.** Turn on the network analyzer.
- The line switch should glow green.
 - The fans should be audible.
 - The display should flash and then show the hardware boot-up sequence. This process checks the RAM and communication with the hard disk drive. These checks return an error message if a problem is detected.
 - The Windows operating system should start.
 - The network analyzer measurement interface should open with an S₁₁ measurement displayed.
- Step 3.** If the analyzer powers up correctly, continue troubleshooting with **“Front Panel Troubleshooting”** on page 4-16.
- Step 4.** If the analyzer does not power up correctly, follow these troubleshooting steps:
- If the line switch does not glow, go to **“Power Supply Check”** on page 4-9.
 - If you cannot hear the fans operating, go to **“If the Fans Are Not Operating”** on page 4-13.
 - If the line switch glows green and the fans are operating (audible), but the display remains dark, go to **“Troubleshooting LCD Display Problems”** on page 4-14.
 - If the instrument appears to abort the network analyzer measurement interface process, contact Keysight. Refer to **“Contacting Keysight”** on page 2-8.

Power Supply Check

NOTE

There are no fuses to replace within the power supply. If you determine that the power supply is the failed assembly, replace the power supply.

A catastrophic failure in the power supply can be determined by observing the line switch and the power supply LED indicators:

1. Ensure that the instrument is plugged in with the power switch in the standby position (power not switched on). Verify that the line switch glows yellow. A line switch that glows yellow indicates that the power supply is providing enough voltage to light the LED. (However, the voltage may not actually be the correct voltage.)
2. Turn on the instrument power and verify that the line switch glows green. When the line switch glows green, it is an indication that the power supply has received an “ON” command and that the power supply can provide enough current to light, at least, this LED.
3. You can determine which power supplies are functioning by viewing the LED indicators on the A15 midplane board. Refer to [Figure 4-2](#).

To view the LED indicators, it is necessary to remove the instrument's outer and inner covers. Refer to [“Removing the Covers” on page 7-5](#) for removal procedures. To determine the location of the A15 midplane board, refer to [“Top Assemblies, All Options” on page 6-12](#).

CAUTION

Do not operate the analyzer with the outer cover removed for more than 30 minutes, as this could cause the analyzer to overheat which could result in costly damage.

4. If any power supply voltage is missing, it is likely that the problem is a defective A16 power supply, the A15 midplane board, or another assembly that is loading down the A16 power supply. Continue with [“If Any Supply Voltage Is Missing” on page 4-11](#) to determine the cause of the problem.
5. If the line switch is lit correctly, and all the power supply voltages appear to be present, as indicated by the LEDs as shown in [Figure 4-2](#), the power supply has not suffered a catastrophic failure. However, the power supply could still be at fault. Continue at [“Measure the Individual Supply Voltages”](#) to verify that the actual supply voltages are correct.

Measure the Individual Supply Voltages

Measure the power supply voltages using a digital multi-meter. Use the point labeled ACOM as ground reference for analog supplies and the point marked DCOM as ground reference for digital supplies.

Refer to [Figure 4-2](#) for the power supply measurement points on the A15 midplane board. Refer to [Table 4-2 on page 4-11](#) for the correct voltages.

Figure 4-2 A15 Midplane Board Power Supply LED Indicators and Measurement Points

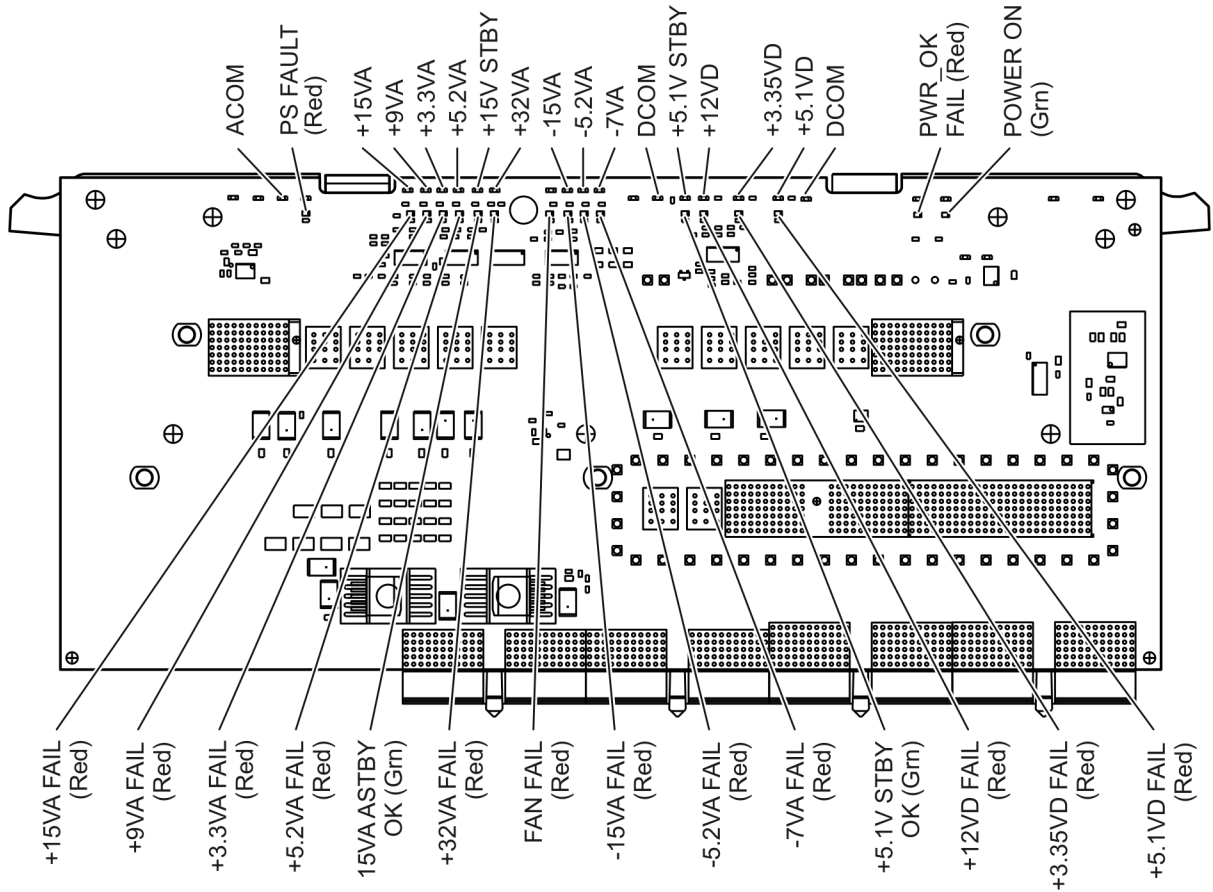

n5242_001_402

WARNING

The instrument contains potentially hazardous voltages. Refer to the safety symbols provided on the instrument and in **“General Safety Considerations”** on page 1-3 before operating the unit with the cover removed. Make sure that the safety instructions are strictly followed. Failure to do so can result in personal injury or loss of life.

CAUTION

Do not operate the analyzer with the outer cover removed for more than 30 minutes, as this could cause the analyzer to overheat which could result in costly damage.

NOTE

If any one individual voltage supply from the A16 power supply develops an over-voltage or over-current problem, all supplies are affected. The cause of the over-voltage or over-current condition can be the A16 power supply itself, or any assembly to which the A16 power supply provides voltage. To isolate the cause, continue to the assembly removal process as described in the section titled **“If Any Supply Voltage Is Missing”** on [page 4-11](#).

Table 4-1 Power Supply Measurement Points

Test Point	Supply Name	Expected Level (Vdc)	Test Point	Supply Name	Expected Level (Vdc)
TP517	Analog Ground	0 V	TP516	-5.2 V analog	-5.2 ±0.1
TP509	+15 V analog	+15.0 ±0.1	TP514	-7 V analog	-7.0 ±0.1
TP511	+9 V analog	+9.0 ±0.1	TP500	Digital Ground	0 V
TP515	+3.5 V analog	+3.5 ±0.1	TP502	+5.1 V standby	+5.1 ±0.1
TP513	+5.2 V analog	+5.2 ±0.1	TP503	+12 V digital	+12.0 ±0.1
TP501	+15 V standby	+15.0 ±0.1	TP507	+3.35 V digital	+3.35 ±0.1
TP504	+32 V analog	+32.0 ±0.1	TP505	+5.1 V digital	+5.1 ±0.1
TP512	-15 V analog	-15.0 ±0.1	TP519	Digital Ground	0 V

If All Supply Voltages are Present

If all of the supplies have measured within tolerances, and the instrument still is not functioning properly, refer to **“Front Panel Troubleshooting”** on [page 4-16](#).

If Any Supply Voltage Is Missing

WARNING

Disconnect the line-power cord before removing any assembly. Procedures described in this document may be performed with power supplied to the product while protective covers are removed. Energy available at many points may, if contacted, result in personal injury or loss of life

You must sequentially remove all of the assemblies, taking care to disconnect the line power cord before each removal, and then measure the supply voltages after each removal.

If the missing supply voltages return to a “power on” condition after removal of an assembly, suspect that assembly as being defective.

Remove the network analyzer assemblies in the order specified in the following steps (refer to [Chapter 7](#) for removal instructions).

1. Unplug the A19 test set motherboard ribbon cable from the A19 test set motherboard (refer to “[Removing and Replacing the A19 Test Set Motherboard](#)” on page 7-32).
2. Unplug the A19 test set motherboard to A20 IF multiplexer board ribbon cable from the A20 IF multiplexer board (refer to “[Removing and Replacing the A20 IF Multiplexer Board](#)” on page 7-35).
3. Unplug the front panel interface cable from the A1 front panel interface board (refer to “[Removing the A1 Front Panel Interface Board and Keypad Assembly](#)” on page 7-9).
4. Remove the A12 board (refer to “[Removing and Replacing the A10, A11, and A12 Boards \(For analyzers with serial numbers prefixed MY/SG/US5144 and below.\)](#)” on page 7-17).
5. Remove the A11 13.5 GHz synthesizer board (refer to “[Removing and Replacing the A10, A11, and A12 Boards \(For analyzers with serial numbers prefixed MY/SG/US5144 and below.\)](#)” on page 7-17).
6. Remove the A10 frequency reference board (refer to “[Removing and Replacing the A10, A11, and A12 Boards \(For analyzers with serial numbers prefixed MY/SG/US5144 and below.\)](#)” on page 7-17).
7. Remove the A18 GPIB board (refer to “[Removing and Replacing the A18 GPIB Board](#)” on page 7-30). Reinstall the A16 power supply assembly and the A17 CPU board assembly.
8. Unplug the A51 hard disk drive from the A17 CPU board (refer to “[Removing and Replacing the A51 Solid State Drive \(SSD\)](#)” on page 7-39).

The minimum required assemblies to power up the analyzer are:

- A16 power supply
- A15 midplane board
- A14 system motherboard
- A17 CPU board

To further isolate the failure in the three remaining assemblies, measure the resistance (with the power turned off) from the power supply test points to either ACOM or DCOM.

NOTE

Make sure that the only assemblies plugged in are the four minimum required assemblies listed above.

Check for shorts (zero Ω) or very low resistance (approximately 1 Ω). If a short or low resistance is measured, isolate each of the remaining four boards in the following order, and recheck the shorted test point after each board is removed. You should be able to determine if the shorted condition has changed.

Isolate the remaining three assemblies:

- remove the A17 CPU board
- remove the A16 power supply
- remove the A15 midplane board
- This leaves only the A14 system motherboard installed. If the resistance measurements are still incorrect, this is the suspected faulty assembly.

If the Fans Are Not Operating

CAUTION

The power supply may be in thermal shutdown if the instrument has been operating without the fans running. Allow the instrument to cool down before troubleshooting.

If all three fans are not operating, suspect a power supply problem or a defective A14 system motherboard. Refer to **“Power Supply Check” on page 4-9** to check the individual supplies. If the supplies are within specifications, the most probable cause is a defective A14 system motherboard. Refer to **“Removing and Replacing the A14 System Motherboard” on page 7-21**.

If only one or two fans are not functioning, and the power supplies are within specifications, suspect the A14 system motherboard or defective fan(s). Perform the following procedure.

1. Remove the fan bracket, with fans attached, from the analyzer to expose the fan power cable connections on the A14 system motherboard. Refer to **Figure 4-3** for location of these connections. Refer to **“Removing and Replacing the Fans” on page 7-43**.
2. Plug in the power cord and measure the fan voltages at all three connectors on the A14 system motherboard. **THIS MUST BE DONE QUICKLY AS THE ANALYZER WILL RAPIDLY OVERHEAT WITHOUT THE COOLING EFFECT OF THE FANS. DO NOT PLUG IN THE POWER CORD UNTIL READY TO PERFORM MEASUREMENTS.**

Figure 4-3 Fan Power Cable Connections

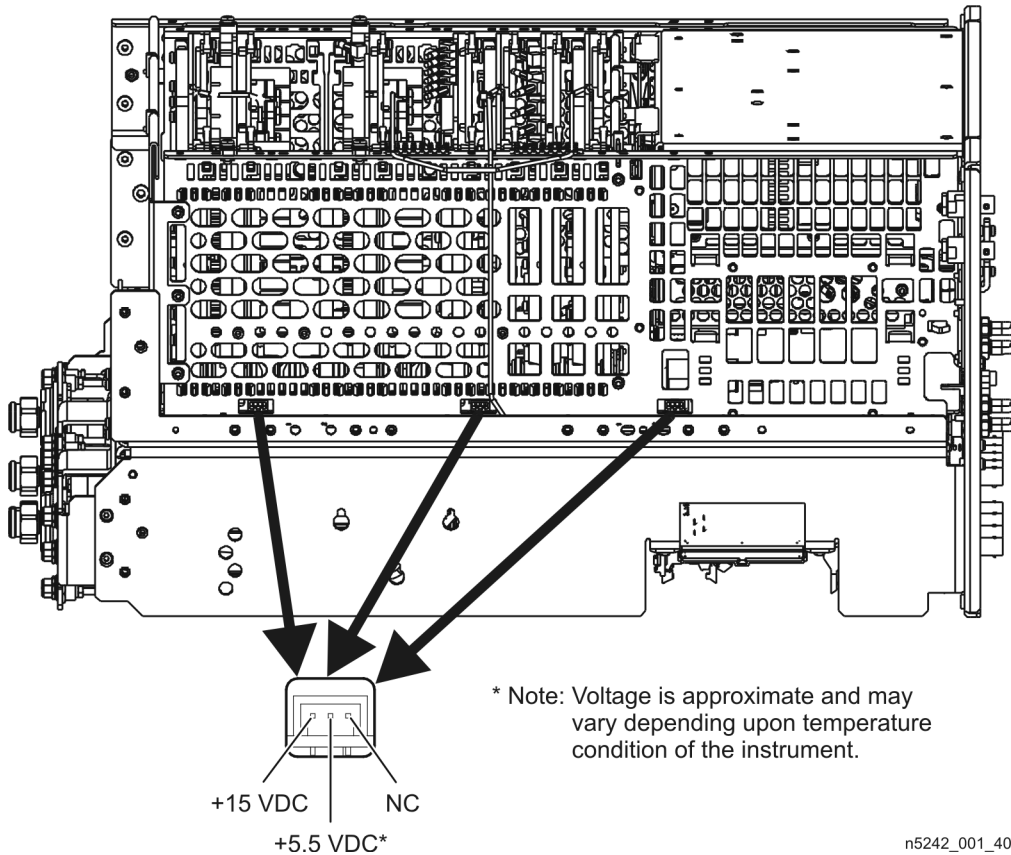

3. If the correct voltage is present at each connection and the fan connectors are in good mechanical condition, suspect a defective fan. Refer to [“Removing and Replacing the Fans” on page 7-43.](#)
4. If the correct voltage is not present, suspect a defective A14 system motherboard. Refer to [“Removing and Replacing the A14 System Motherboard” on page 7-21.](#)

Troubleshooting LCD Display Problems

This procedure is intended to isolate the faulty assembly when the display is dark. If the display is lit, but the color mix is faulty, refer to [“A3 Display Test” on page 4-19.](#)

NOTE

There are no front panel adjustments for intensity and contrast of the LCD.

1. If the display is dim, the A3 display assembly is defective. Refer to [“Removing and Replacing the A1–A3 and Other Front Panel Subassemblies” on page 7-9.](#)

2. If the display is dark (not visible), connect an external VGA monitor to the rear panel Monitor output connector. (Be aware that some multisync monitors might not be able to lock to a 60 Hz sync pulse.) If the video information is not present on the external VGA monitor, the most probable cause is the A17 CPU board. Refer to **“Removing and Replacing the A17 CPU Board Assembly” on page 7-28.**
3. If the external VGA monitor displays the correct information, verify that the front panel interface ribbon cable is properly plugged into the motherboard connector. Refer to **“Removing and Replacing the Front Panel Assembly” on page 7-7.**
4. If the front panel interface ribbon cable is properly connected, suspect that one or more of the following is defective:
 - inverter board (mounted on the display assembly)
 - A1 front panel interface board
 - A3 display assembly

Front Panel Troubleshooting

The front panel assembly consists of the A1 front panel interface board, the keypad, the A2 USB board, and the A3 display assembly. The following tests verify the operation of the front panel assembly when the analyzer is in the measurement mode. If the instrument fails to power up correctly, or it is difficult to verify due to a faulty display, refer to **“Power Up Troubleshooting” on page 4-8**.

Refer to the following sections to verify the operation of the noted assemblies.

- **“Front Panel Keypad and RPG Test”** on this page
- **“A3 Display Test” on page 4-19**
- **“Checking the A2 USB Board” on page 4-20**
- **“A1 Front Panel Interface Board” on page 4-21**

If all assemblies are working correctly, continue troubleshooting with **“Rear Panel Troubleshooting” on page 4-23**.

Front Panel Keypad and RPG Test

Test the front panel keypad by running the front panel test. To run the front panel test, perform the following:

Press UTILITY **System**, then **Service**, then **Diagnostics**, then **Front Panel Test**.

A **Front Panel Key Test Utility** dialog box will be displayed, as shown in **Figure 4-4**.

Figure 4-4 Front Panel Key Test Utility Dialog Box

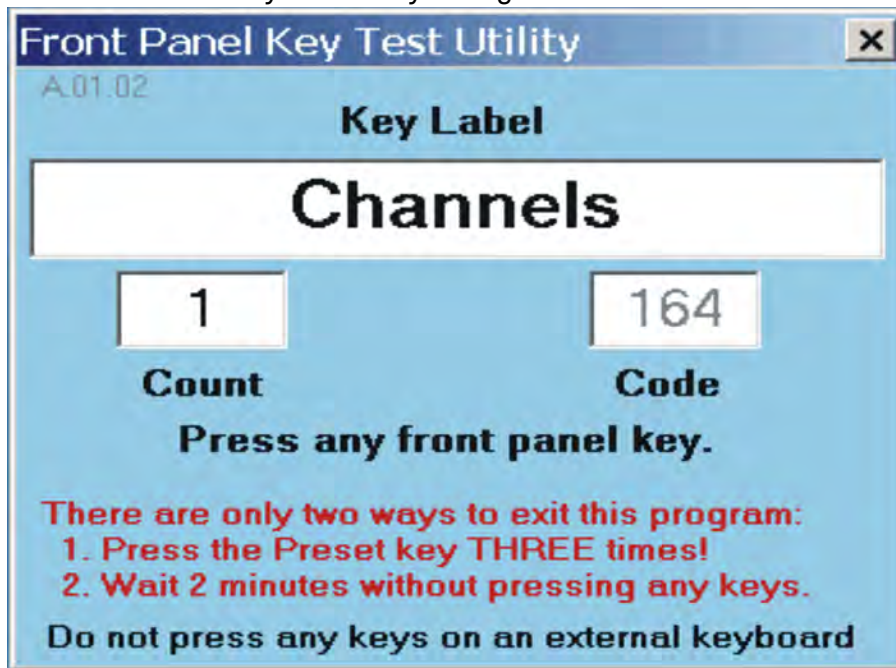

n5242_001_403

Checking the Front Panel Keys

To check the front panel keys, push each key and compare the name in the Key Label box to the name physically labeled on the key cap. These names are also in [Table 4-2](#) below. Verify that the Key Label and the Codes match.

- If all the key names are correct, then the front panel keypad is working. If some of the keys are not working, suspect a faulty keypad. To replace the keypad, refer to [“Removing the A1 Front Panel Interface Board and Keypad Assembly” on page 7-9](#).
- If none of the keys are working correctly, suspect a faulty touchscreen controller board or the A1 front panel interface board. To replace the touchscreen controller board, refer to [“Removing the Touchscreen Controller Board” on page 7-10](#). To replace the A1 front panel interface board, refer to [“Removing the A1 Front Panel Interface Board and Keypad Assembly” on page 7-9](#).
- To close the Key Label window and return to the instrument display, press **Preset** three times.

Table 4-2 Front Panel Keyboard Key Names

INSTRUMENT Keys	Keypad Code	STIMULUS Keys	Keypad Code	ENTRY^a Keys	Keypad Code	ENTRY^a Keys (cont.)	Keypad Code
Prev	239	Freq	223	OK	154	1	198
Next	240	Power	157	Cancel	186	2	199
Trace	160	Sweep	163	Bk Sp	233	3	192
Channel	164	Trigger	171	T/p	242	k/m	232
Display	238	Navigation^a Keys	Keypad Code	7	182	0	206
Setup	241	Knob (CW)	101	8	183	. (decimal point)	207
RESPONSE Keys	Keypad Code	Knob (CCW)	102	9	176	+/-	201
Meas	179	Click (Rotary Knob press)	159	G/n	177	Enter Off	193
Format	180	↑	151	4	190	UTILITY Keys	Keypad Code
Scale	181	←	150	5	191	Save/Recall	203
Math	197	→	152	6	184	Macro	213
Avg BW	172	↓	158	M/u	185	Undo	243
Cal	173					System	231
Marker	187					Help	170
Search	195					Preset	205

a. There are no Entry or Navigation labels on the display. Entry and Navigation titles are for functional reference only.

Checking the RPG (Front Panel Knob)

NOTE

This section assumes you have completed the introduction and opened the Front Panel Key Test Utility window. Refer to [“Front Panel Keypad and RPG Test” on page 4-16](#).

To check the RPG knob:

1. Rotate the knob clockwise (cw) and check for a fluid movement of numbers on the analyzer display and verify that **Knob Rotate CW** is displayed. Refer to [Figure 4-5](#).

Figure 4-5 RPG Knob Clockwise Verification

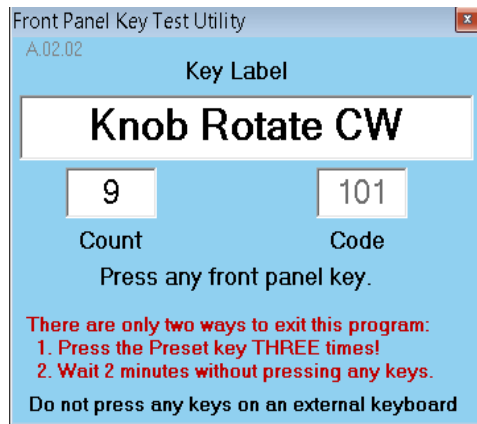

2. Rotate the knob counter clockwise (ccw) and check for a fluid movement of numbers on the analyzer display and verify that **Knob Rotate CCW** is displayed.
3. Press the knob and verify that **Knob Click** is displayed.
4. If the movement of numbers is not smooth or no numbers appear at all, suspect a faulty RPG board or the A1 front panel interface board. To replace the RPG board, refer to [“Removing the RPG Assembly” on page 7-9](#). To replace the A1 front panel interface board, refer to [“Removing the A1 Front Panel Interface Board and Keypad Assembly” on page 7-9](#).
5. When done to close the Key Label window and return to the instrument display, press **Preset** three times.

A3 Display Test

The display should be bright with all annotations and text readable. The display test allows you to check for non-functioning pixels and other problems.

NOTE

If the display is dark, refer to [“Removing the A3 Display Assembly and the Touchscreen” on page 7-11](#) and to [“Removing the Touchscreen Controller Board” on page 7-10](#).

What Is a Damaged Pixel?

A pixel is a picture element that combines to create the image on the display. A pixel is about the size of a small pin point.

A damaged pixel is a pixel that has a constant blue, green, red, black, or other color appearance that will not change.

How to Run the Display Test

To run the display test, perform the following:

Press UTILITY **System**, then **Service**, then **Diagnostics**, then **Display Test...**

A multi-color screen is displayed. Be prepared to look for the symptoms described in **“How to Identify a Faulty Display.”** Follow the instructions on the screen.

How to Identify a Faulty Display

A display is considered faulty if:

- More than 6 pixels and or any two faulty pixels within 15 mm of each other (used—under warranty) of the total pixels have a constant blue, green, red, or black appearance that will not change.
- Three or more consecutive pixels and or any two faulty pixels within 15 mm of each other, have a constant blue, green, red, purple, black and or other colors, appearance that will not change.
- Also, for the Gray gradient screen, verify their are no black vertical/horizontal lines

If the A3 display assembly is determined to be faulty, replace it. Refer to **“Removing the A3 Display Assembly and the Touchscreen” on page 7-11.**

Checking the A2 USB Board

To verify proper operation of the USB board:

1. Connect a known good USB device, such as a USB mouse, to a front panel USB port.
2. Wait 15 seconds for the analyzer to verify the device connection, and then check the operation of the USB device.
3. If the device performs correctly, the USB board is functioning properly.
Else, skip to step 5.
4. Repeat steps 1 thru 3 for all front and rear USB ports.

5. If the device does not perform correctly, the USB may need to be reset. Use Windows Device Manager to look for any cautions or warnings and repair those first. Refer to Windows Help.

NOTE

The Windows Device Manager can be used to enable/disable the USB drivers and may repair your USB hub(s). Refer to Windows Help.

6. If the device still does not perform correctly, the USB board is faulty. Refer to [“Removing the A2 USB Board” on page 7-9](#).

A1 Front Panel Interface Board

This assembly performs the following functions:

- All signals from the front panel interface board are routed through the motherboard/midplane board to the CPU.
- It routes USB signals between the front-panel USB connector and the A17 CPU board.
- The speaker produces the audio output from signals supplied by the A17 CPU board.
- It routes key pad commands from the keypad to the A17 CPU board.
- It routes display signals from the A17 CPU board to the A3 display assembly.

Checking the Speaker

If no audio is heard:

Verify that the volume is set correctly and the proper sound driver is loaded; do the following:

1. Press **File > Minimize Application**, then press the Speaker icon () on the Windows Toolbar.
2. The windows slider opens. Verify the volume is not muted, then slide volume up or down.
Else, skip to step 4.
3. Optional, if audible tone is heard, reset volume slider to zero or mute.
4. If the audio is still not heard, suspect a faulty speaker. Refer to [“Removing the A1 Front Panel Interface Board and Keypad Assembly” on page 7-9](#) and to [“Removing the Speaker Assembly” on page 7-11](#).

Checking the Operation of the Key Pad Commands

To verify the key pad functionality, refer to [“Front Panel Keypad and RPG Test” on page 4-16](#).

Troubleshooting
Front Panel Troubleshooting

Checking the Display

To verify the display functionality, refer to **“A3 Display Test”** on page 4-19.

Rear Panel Troubleshooting

Each rear panel connector is associated with a hardware group in the analyzer. You can use the data at these rear panel connectors to help troubleshoot these hardware groups in addition to testing the connectors.

The connectors discussed in this section are:

- USB x 4
- Monitor (VGA)
- GPIB (0) CONTROLLER
- GPIB (1) TALKER/LISTENER
- LAN

Checking the USB Ports

To verify proper operation of any rear panel USB port:

- Connect a known good USB device, such as a USB mouse.
- Wait 15 seconds for the analyzer to verify the device connection, and then check the operation of the USB device.
- If the device performs correctly, the USB port is functioning properly.
- If the device does not perform correctly, remove the non-working USB device, wait 15 seconds, and then reconnect the device to the rear panel USB port.
- If the USB device still does not work and has been verified to work elsewhere, then the A17 CPU board is faulty. Refer to **“Removing and Replacing the A17 CPU Board Assembly” on page 7-28.**

Checking the CONTROLLER Port

The network analyzer uses a National Instruments 488.2 GPIB controller and associated driver software. This software includes a test utility that scans the GPIB bus and returns the status of all the connected peripherals.

To run the test utility software and check the GPIB status:

1. Connect a known good peripheral to the analyzer using a **known good** GPIB cable.
2. Press UTILITY **System**, then **Configure**, then **SICL/GPIB...**. A **SICL/GPIB/SCPI** dialog box is displayed.
3. In the **GPIB** block, click **System Controller** to establish the analyzer as a controller. Wait for the analyzer to configure, and then click **OK**.

4. If the Window Desktop is not displayed, press UTILITY **System**, then **Configure**, then **Control Panel...** to view the Windows Taskbar menu at the bottom of the display.
5. On the **Windows Taskbar** menu, click Start then point to **Programs, National Instruments NI-488.2**, and then click **Explore GPIB** to open the **Measurement & Automation** window.
6. On the left side of the **Measurement & Automation** window under folders:
 - a. Click the plus sign to expand the **Measurement & Automation** folder.
 - b. Click the plus sign to expand the **Devices and Interfaces** folder.
 - c. Right click **GPIB0 (AT-GPIB/TNT)** to open a submenu.
7. On the submenu, click **Scan for Instruments** to run the test.
8. The state of all the peripherals found on the bus is returned.
9. If problems are detected, check the connections of all GPIB cables, and check all the GPIB addresses of the instruments on the bus.

NOTE

Address Information

- Each device must have its own unique address.
- The network analyzer's default GPIB address in the controller mode is 21.
- The address set on each device must match the one recognized by the analyzer (and displayed).

Refer to the manual of the peripheral to read or change its address.

Troubleshooting Systems with Controllers

Passing the preceding test indicates that the analyzer's peripheral functions are operating normally. Therefore, if the analyzer has not been operating properly with an external controller, check the following:

- The GPIB interface hardware is incorrectly installed or not operational. (Refer to the embedded help in your analyzer.)
- The programming syntax is incorrect. (Refer to the embedded help in your analyzer.)

LAN Troubleshooting

Problems with the Local Area Network (LAN) can be difficult to solve. Software and protocol problems can make it difficult to determine whether the analyzer's hardware is working properly, or if there is a problem with the LAN or cabling.

The purpose of this section is to determine if the analyzer's hardware is functioning properly. While the turn-on self-test verifies some LAN hardware functionality, it is limited to internal testing only. Incorrect IP addresses will prevent proper operation. Improper subnet masks may allow only one-way communication, while improper gateway addresses may exclude outside LAN access.

Ping Command

The analyzer has the built-in capability of performing a “ping” operation. Ping will request the analyzer to send a few bytes of information to a specific LAN device. That device will then signal the analyzer that it has received the information. The analyzer computes the approximate round trip time of the communication cycle and displays it. For a full test of two-way communications, a ping test should be performed in two directions.

- First: you should ping from the analyzer to the local area network.
- Second: you should ping from the local area network to the analyzer.

NOTE

In the second case, any other network device capable of sending a ping command could be used, assuming it is connected to the same network. This could be a computer or even another analyzer.

How to Ping from the Analyzer to the Local Area Network (LAN)

Follow the steps below to verify proper LAN operation (assuming you have a functioning LAN). If no network LAN is available, see [“Testing Between Two Analyzers” on page 4-27](#).

1. Make sure the IP address on the analyzer is set properly and that it is unique. If unsure how to check the IP address, refer to the embedded help in the analyzer.
2. Make sure the subnet mask is 0.0.0.0. If not, note the current setting (to allow setting it back later) and then set it to 0.0.0.0.
3. Find and note the IP address of another working LAN device on the same network. Make sure this device is turned on, connected, and is functioning properly.
4. To ping the network device:
 - a. If the Windows Desktop is not displayed, press UTILITY **System**, then **Configure**, then **Control Panel...** to view the Windows Taskbar menu at the bottom of the display.
 - b. On the **Windows Taskbar** menu, click **Start**, point to **Programs, Accessories**, and then click **Command Prompt**.
 - c. The command prompt window is displayed.

- d. At the prompt, type `ping xxx.xxx.xxx.xxx`¹ and press ENTRY Enter on the front panel. Refer to Step 5 for the results of a successful ping.
5. The analyzer attempts four cycles of communications with the indicated LAN device.
 - It displays the time it took to complete each cycle.
 - Each cycle times-out after one second if no communication is established and the message, `Request timed out`, is displayed.
 - It is common for the first of the four cycles to time-out even though subsequent cycles pass.
 - See below for an example output of a successful ping.

```
C:>ping 141.121.69.162
```

```
Pinging 141.121.69.162 with 32 bytes of data:
```

```
Reply from 141.121.69.162: bytes=32 time<10ms TTL=127
```

```
Reply from 141.121.69.162: bytes=32 time<10ms TTL=127
```

```
Reply from 141.121.69.162: bytes=32 time<10ms TTL=127
```

```
Reply from 141.121.69.162: bytes=32 time<10ms TTL=127
```

```
Ping statistics for 141.121.69.162:
```

```
Packets: Sent = 4, Received = 4, lost = 0 <0% loss>.
```

```
Approximate round trip times in milli-seconds:
```

```
Minimum = 0ms, Maximum = 0ms, Average = 0ms
```

6. The above message verifies that one way communication from the analyzer to the network has been established
7. If the subnet mask was changed in step 2, set it back at this time.

How to Ping from the Local Area Network (LAN) to the Analyzer

Reverse communication should also be verified. Determining this, though, is dependent upon your network setup and software. Generally, you need to issue a ping command using the IP address of the analyzer to be tested. For example, using Windows 95, 98, 2000, XP, or 7 and while at a DOS prompt, type in `ping xxx.xxx.xxx.xxx`². Then press ENTRY Enter on the front panel. If full communication can be established, then the computer display shows the cycle time for each of four cycle attempts (similar to that in step 5). Other software may behave somewhat differently, but basically the same.

1. The letters x represent the IP address of the other device on the network.
2. The letters x represent the IP address of the analyzer.

If the analyzer can talk to the network, but the network can not talk to the analyzer, then the computer or device used from the network may have a subnet mask that excludes communication with the IP address chosen for the analyzer. Any subnet mask other than 0.0.0.0 will exclude operation from some addresses. Changing the subnet mask of a computer or other device should only be attempted by a qualified network administrator. Failure to communicate due to a subnet mask incompatibility does not indicate any failure of the analyzer.

If the analyzer fails to ping in either direction, and assuming the subnet masks are set properly, then the fault must be isolated to the analyzer or to the network. Contact a qualified network administrator.

Testing Between Two Analyzers

The ability of the analyzer's LAN to function can be easily tested by connecting two analyzers together using a "crossover cable" (a short length of cable with an RJ-45 connector on each end).

Some network hubs have the capability to make a crossover connection using two normal, or straight-through, cables. If this capability is not available and a crossover cable is not available, a crossover cable can be made by following the directions in **"Constructing a Crossover Cable" on page 4-27**.

Set the IP addresses on two analyzers. The addresses can be set to anything, but they must be different. Make sure the subnet mask and gateway addresses are set to 0.0.0.0 and that the LAN is active on both analyzers. Connect the two analyzers together using either a crossover cable or a crossover hub.

Now follow the steps in **"How to Ping from the Analyzer to the Local Area Network (LAN)" on page 4-25** to have the first analyzer ping the second analyzer. When done, repeat the procedure having the second analyzer ping the first. If both procedures function properly, the LAN circuitry on both analyzers is verified.

If neither function properly:

- One or both IP addresses could be wrong.
- One or both LAN states could be set to off.
- The crossover cable could be miswired.
- One or both analyzers could be defective.

If possible, eliminate the possibility of a defective analyzer by substitution of a known working unit. Once the analyzer has been proven to be working properly, concentration can be placed on the network itself to determine the cause of the failure.

Constructing a Crossover Cable

A crossover cable can be made from a standard LAN cable by connecting pin 1 from each connector to pin 3 of the other connector, and pin 2 from each connector to pin 6 of the other connector.

1. Strip away a few inches of the outside jacket insulation from the middle of a standard LAN cable that has an RJ-45 connector on each end.

NOTE

Pins 1, 2, 3, and 6 of the connectors must be located to determine which wires to cut in the following steps. Most, but not all, LAN cables use the color coding listed in [Table 4-3](#). If your cable does not use this color scheme, you will have to determine the locations of the appropriate wires before proceeding with this procedure.

Table 4-3 LAN Pin Definitions and Wire Color Codes

Pin Number	Color	Pin Number	Color
1 (transmit +)	White/orange	5	White/blue
2 (transmit -)	Orange	6 (receive -)	Green
3 (receive +)	White/green	7	White/brown
4	Blue	8	Brown

2. Cut the wires going to pins 1, 2, 3, and 6. Strip away a small amount of insulation from each of the eight cut ends.
 - a. Connect the wire from pin 1 on one end of the cable to the wire from pin 3 on the other end of the cable.
 - b. Connect the wire from pin 3 on one end of the cable to the wire from pin 1 on the other end of the cable.
 - c. Connect the wire from pin 2 on one end of the cable to the wire from pin 6 on the other end of the cable.
 - d. Connect the wire from pin 6 on one end of the cable to the wire from pin 2 on the other end of the cable.
3. Insulate all exposed wires so that they cannot short together.
4. Label this as a crossover cable so that it cannot be confused with a standard cable.

Figure 4-6 Construction of a Crossover Cable

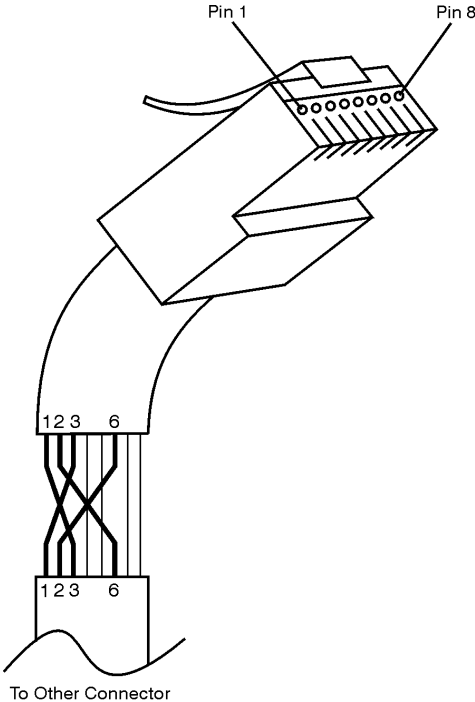

sd623c

Instrument Block Diagram

N5264B PNA-X Measurement Receiver

REAR PANEL INTERCONNECTS

N5264B Overall Block Diagram
 (Includes Options 700 - Standard; 108 - LO Source
 Service Guide: N5264-90026

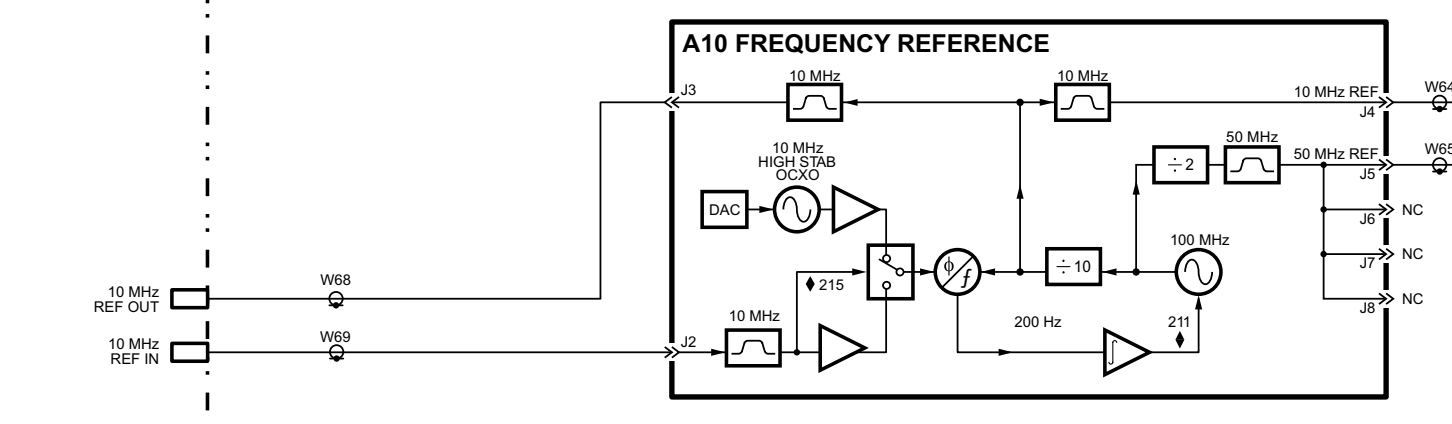
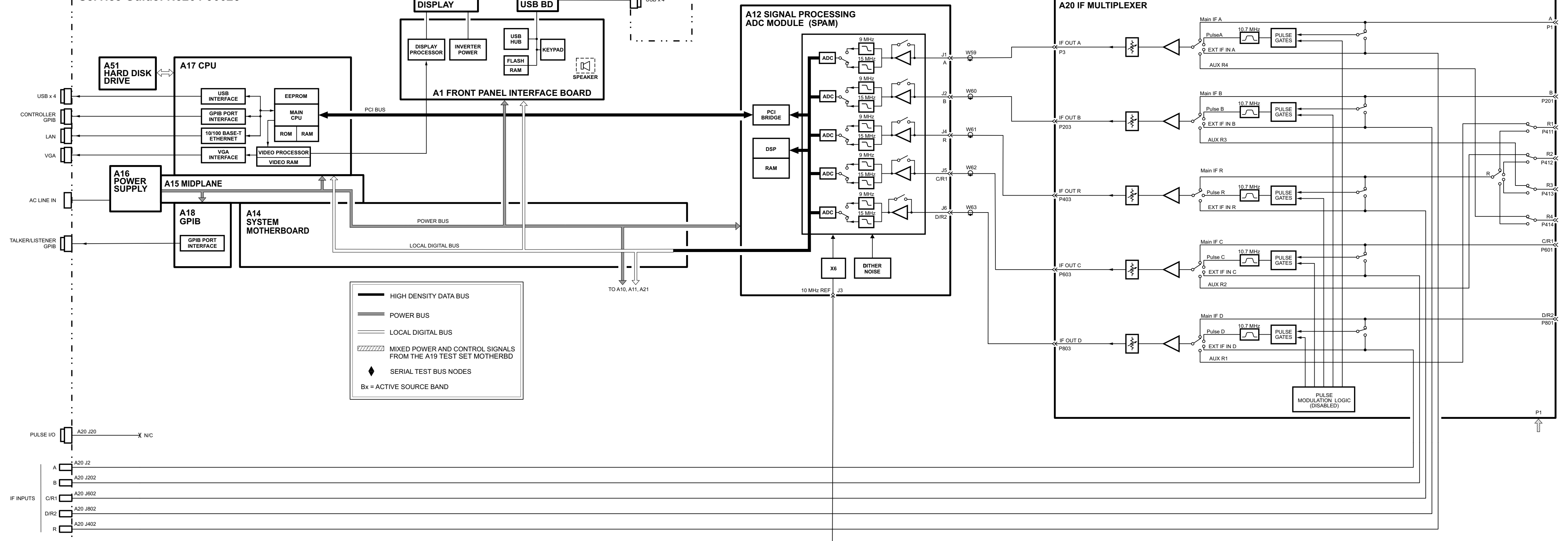

OPTION 108

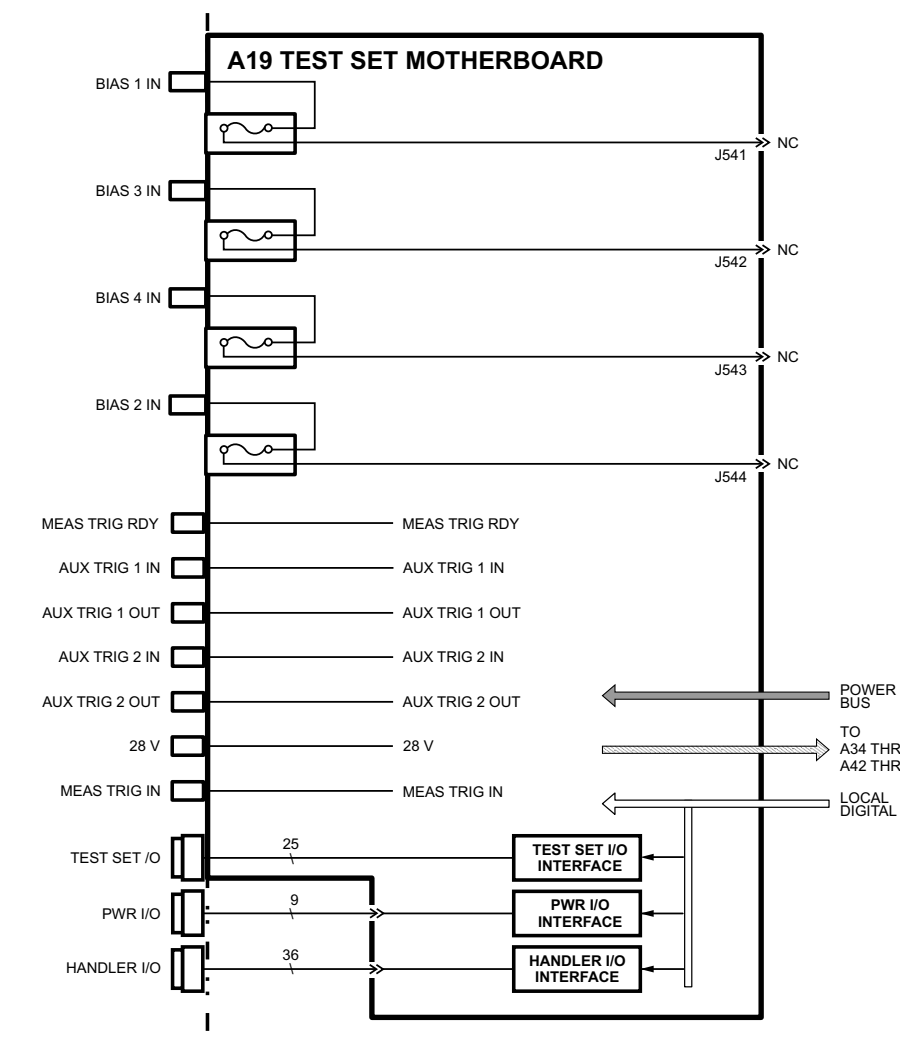
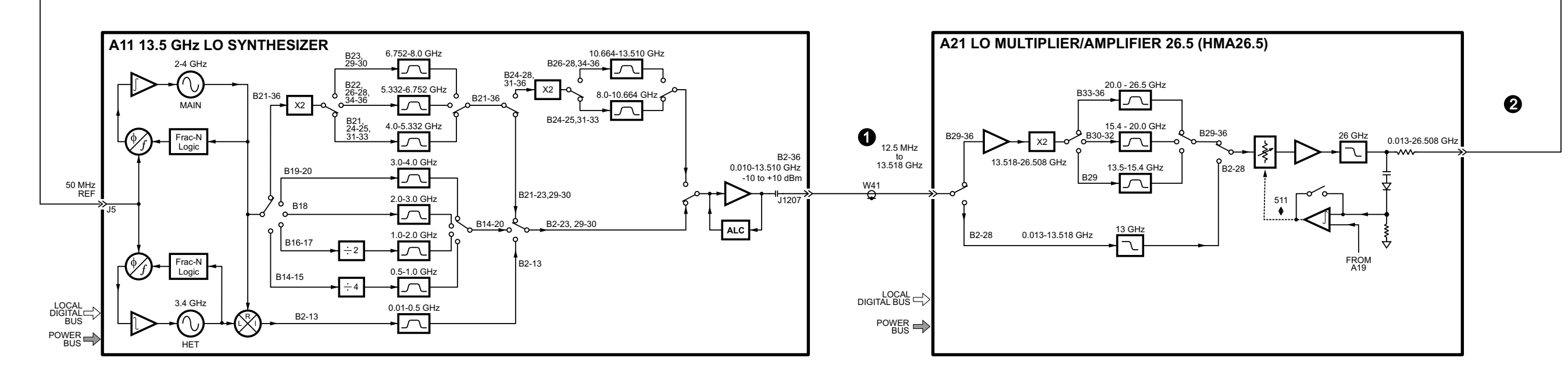

Band	Mixer Brick L.O. Harmonic Number (N)	1 A11 Synthesizer Frequency (GHz)	2 A21 HMA26.5 Frequency (GHz)
0	-	-	-
1	-	-	-
2	1	0.01761 to 0.50761	0.01761 to 0.50761
3	1	0.50761 to 1.00761	0.50761 to 1.00761
4	1	1.00761 to 2.00761	1.00761 to 2.00761
5	1	2.00761 to 3.00761	2.00761 to 3.00761
6	1	3.00761 to 4.00761	3.00761 to 4.00761
7	1	4.00761 to 5.33961	4.00761 to 5.33961
8	1	5.33961 to 6.75961	5.33961 to 6.75961
9	1	6.75961 to 8.00761	6.75961 to 8.00761
10	1	8.00761 to 10.67161	8.00761 to 10.67161
11	1	10.67161 to 13.51761	10.67161 to 13.51761
12	1	6.758803 to 7.703803	13.51761 to 15.40761
13	1	7.703803 to 8.003803	15.40761 to 16.00761
14	1	8.003803 to 10.00381	16.00761 to 20.00761
15	1	10.00381 to 10.66781	20.00761 to 21.33561
16	1	10.66781 to 13.25381	21.33561 to 26.50761

Troubleshooting
Instrument Block Diagram

5 Theory of Operation

Information in This Chapter

This chapter provides a general description of the operating theory of the N5264B PNA-X measurement receiver.

- Theory of operation is explained to the assembly level only.
- Component-level circuit theory is not provided.
- A simplified block diagram is included for each functional group.
- A more detailed block diagram is located at the end of **Chapter 4, “Troubleshooting.”**

NOTE

Although simplified block diagrams are included within the description of each functional group, it is recommended that the more detailed block diagram, located at the end of **Chapter 4**, be available for reference as you read the information in this chapter.

Chapter Five at-a-Glance

Section Title	Summary of Content	Start Page
Measurement Receiver System Operation	A summary of the theory of operation for the analyzer. A summary of the operation of the major functional groups of the analyzer.	page 5-2
Synthesized LO Group Operation (Option 108)	Operation of the assemblies associated with the source group.	page 5-4
IF Multiplexer Group Operation	Operation of the assemblies associated with the receiver group.	page 5-12
Digital Processing and Digital Control Group Operation	Operation of the assemblies associated with digital processing and digital control.	page 5-14
Power Supply Group Operation	Operation of the power supply assembly group.	page 5-19

Measurement Receiver System Operation

External IF INPUT signals are routed through the IF multiplexer to the digital processor where they are processed for display.

The Option 108 PNA-X measurement receiver generates an LO signal from the internal synthesized source that is available at the rear panel LO OUT connector.

Figure 5-1 is a simplified block diagram of the measurement receiver system.

Figure 5-1 System Simplified Block Diagram

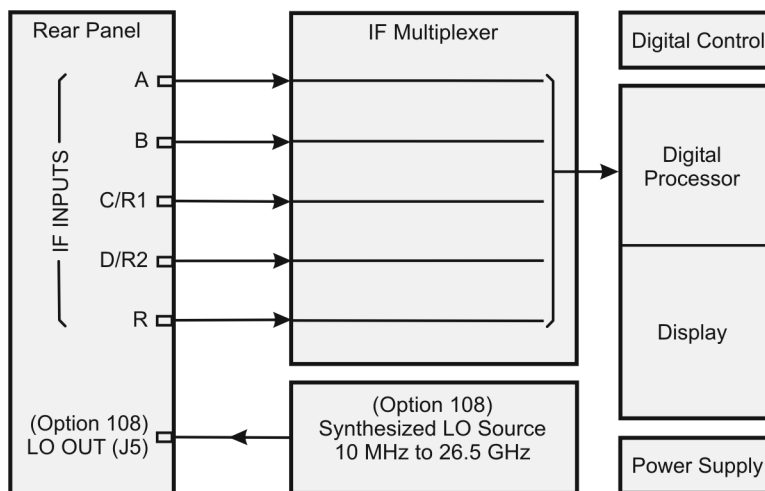

n5264_001_501

Functional Groups of the Measurement Receiver

The operation of the network analyzer can be separated into major functional groups. Each group consists of assemblies that perform a distinct function in the instrument. Some of the assemblies are related to more than one group, and all of the groups, to some extent, are interrelated and affect each other's performance. The major functional groups are:

- **Synthesized LO Group (Option 108)**
- **IF Multiplexer Group**
- **Digital Processor and Digital Control Group**
- **Power Supply Group**

Synthesized LO Group (Option 108)

The built-in synthesized source generates a swept, stepped, or continuous wave (CW) signal in the frequency ranges as listed in [Table 5-2](#).

The LO signal is sent directly to the rear panel LO OUT connector.

Refer to [“Synthesized LO Group Operation \(Option 108\)” on page 5-4](#).

IF Multiplexer Group

The IF multiplexer group provides five rear panel IF input signals that are sent to the A12 SPAM board for digital processing.

Refer to [“IF Multiplexer Group Operation” on page 5-12](#).

Digital Processor and Digital Control Group

The digital processor and digital control group are divided into a front panel group and a data acquisition and processing group. The front panel group provides communication to the network analyzer. The data acquisition and processing group provides the output to the display, in addition to signal processing and analyzer control.

Refer to [“Digital Processing and Digital Control Group Operation” on page 5-14](#).

Power Supply Group

The power supply functional group provides power for the other assemblies in the instrument.

Refer to [“Power Supply Group Operation” on page 5-19](#).

Synthesized LO Group Operation (Option 108)

The LO group produces a stable LO output signal by phase locking a synthesized voltage-controlled oscillator (VCO). Refer to [Table 5-2 on page 5-6](#) for the full frequency range of the source. The outputs at the front panel test ports are swept, stepped or CW signals. Maximum leveled output powers are listed in [Table 5-2 on page 5-6](#). For a simple block diagram of the source group, refer to [Figure 5-2 on page 5-5](#).

In this section the following are described:

- **Basic Operation**
- **A10 Frequency Reference Board** (including rear-panel interconnects)
- **A11 13.5 GHz LO Synthesizer Board (Option 108)**
- **A21 Multiplier/Amplifier 26.5 Board (HMA26.5) (Option 108)**
- **A19 Test Set Motherboard** (including rear-panel interconnects)

Basic Operation

[Table 5-2 on page 5-6](#) lists the A11 LO synthesizer frequency and the A21 HMA26.5 output frequency for each band. This table is referred to throughout this chapter and also appears on the overall block diagram at the end of [Chapter 4, “Troubleshooting.”](#)

The A10 frequency reference board produces a constant phase locked reference signal of 50 MHz that is sent to the A11 13.5 GHz LO synthesizer board.

The A11 13.5 GHz synthesizer board produces an LO signal that is sent through the A21 multiplier/amplifier 26.5 (HMA26.5) to the rear panel LO OUT connector.

Figure 5-2 Synthesized LO Group (Option 108)

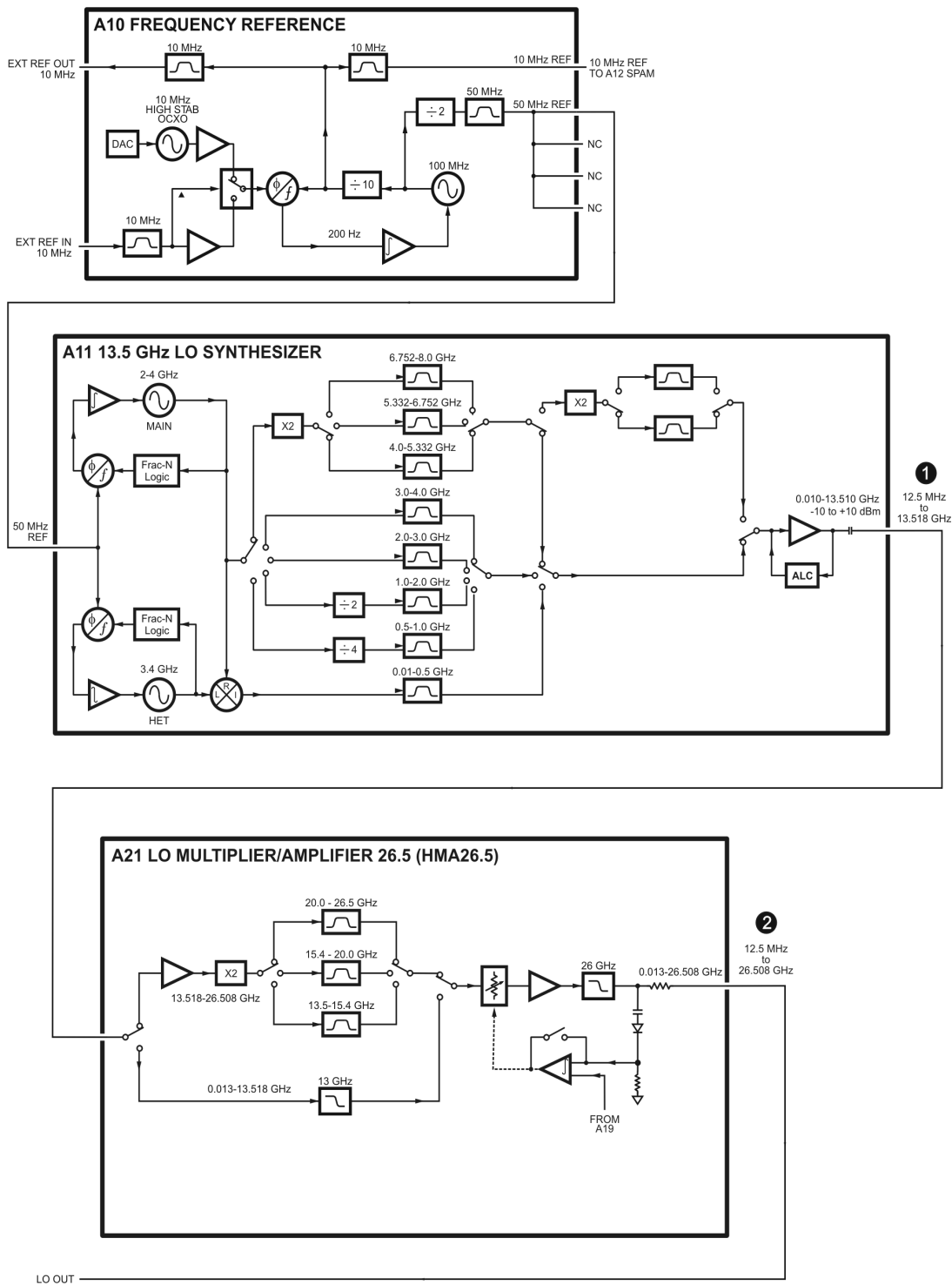

n5264_001_502

Band	LO Harmonic Number (N)	A11 Synthesizer Frequency (GHz)	A21 HMA26.5 Frequency (GHz)
0	-	-	-
1	-	-	-
2	1	0.01761 to 0.50751	0.01761 to 0.50751
3	1	0.50761 to 1.00761	0.50761 to 1.00761
4	1	1.00761 to 2.00761	1.00761 to 2.00761
5	1	2.00761 to 3.00761	2.00761 to 3.00761
6	1	3.00761 to 4.00761	3.00761 to 4.00761
7	1	4.00761 to 5.33961	4.00761 to 5.33961
8	1	5.33961 to 6.75961	5.33961 to 6.75961
9	1	6.75961 to 8.00761	6.75961 to 8.00761
10	1	8.00761 to 10.67161	8.00761 to 10.67161
11	1	10.67161 to 13.51761	10.67161 to 13.51761
12	1	6.758803 to 7.703803	13.51761 to 15.40761
13	1	7.703803 to 8.003803	15.40761 to 16.00761
14	1	8.003803 to 10.00381	16.00761 to 20.00761
15	1	10.00381 to 10.66781	20.00761 to 21.33561
16	1	10.66781 to 13.25381	21.33561 to 26.50761

A10 Frequency Reference Board

This assembly provides stable reference frequencies to the rest of the instrument. A high stability 10 MHz oven-controlled crystal oscillator (OCXO) normally provides the frequency standard. However, if a 10 MHz external reference signal is detected at the 10 MHz EXT REF IN port on the rear panel, it is used as the frequency reference instead.

The 10 MHz reference signal is used to phase lock a 100 MHz VCO. The output of this VCO is then divided by ten to produce the 10 MHz EXT REF OUT rear panel signal and also a 10 MHz reference signal for the A12 signal processing ADC module (SPAM) board. The VCO output is also divided by two to produce a 50 MHz reference signal for the A11 13.5 GHz LO synthesizer board.

Rear-Panel Interconnects

10 MHz REF INPUT (s/n prefixes <6021 only)	A BNC connector that allows an external frequency reference signal to be used to phase lock the analyzer for increased frequency accuracy. The analyzer automatically enables the external frequency reference feature when a signal is connected to this input. When the signal is removed, the analyzer automatically switches back to its internal frequency reference.
10 MHz REF OUTPUT (s/n prefixes <6021 only)	A BNC connector that allows a 10 MHz reference signal, produced by the A10 frequency reference board, to be output for use in phase locking external test equipment.

A11 13.5 GHz LO Synthesizer Board (Option 108)

The A11 13.5 GHz LO synthesizer board uses the 50 MHz reference signal from the A10 frequency reference board to tune two VCO circuits: one that sweeps from 2 GHz to 4 GHz and one that is set to a fixed CW frequency of 3.4 GHz.

In bands 2-13, the 3.4 GHz signal is mixed with 3.41 GHz to 3.90 GHz signals from the 2-4 GHz oscillator to produce the output frequencies of 10 MHz to 500 MHz as listed in [Table 5-2](#).

In bands 14 and 15, the output of the swept VCO is passed through a divide-by-4 circuit to produce the output frequencies listed in [Table 5-2](#).

In bands 16 and 17, the swept VCO signal is passed through a divide-by-2 circuit to produce the output frequencies listed in [Table 5-2](#).

In bands 18-20, the swept VCO signal is passed directly to the output of the synthesizer board to produce the output frequencies listed in [Table 5-2](#).

In bands 21-36, the swept VCO signal is passed through a doubler circuit where bands 21-23 and 29-30 are sent directly to the output of the synthesizer board while bands 26-28 and 34-36 are passed through another doubler circuit then to the output of the synthesizer board to produce the output frequencies listed in [Table 5-2](#).

A21 Multiplier/Amplifier 26.5 Board (HMA26.5) (Option 108)

In bands 2-28, the synthesized LO input is filtered, amplified, and passed through to the rear panel LO OUT connector. In bands 29-36, the input is amplified, doubled, and filtered, then sent to the output.

Together, these signal paths create the full output frequency range of 12.5 MHz to 26.508 GHz that is sent to the rear panel LO OUT connector.

A19 Test Set Motherboard

The A19 test set motherboard serves these functions:

- to act as an interface between the A17 CPU board and the auxiliary rear panel interconnects.

- to provide ALC signals to the A21 HMA26.5.

Rear Panel Interconnects

The A19 test set motherboard includes the following rear panel interconnects.

TEST SET I/O	<p>A DB-25 female connector that is used to control external test sets. The external test set bus consists of 13 multiplexed address and data lines, three control lines, and an open-collector interrupt line. Pin assignments are listed in Table 5-1 on page 5-8.</p> <p>Up to 16 test sets may be “daisy-chained” on the bus at one time.</p> <p>The Test Set I/O is not compatible with 8753 network analyzer test sets.</p>
HANDLER I/O	<p>A rectangular 36-pin, female connector providing four independent parallel input/output ports, nine control signal lines, one ground, and a power supply line. This connector has Type 2 output pin assignments as listed in Table 5-2 on page 5-9.</p> <p>All signals are TTL-compatible. Data input/output ports consist of two 8-bit output ports (Port A and Port B) and two 4-bit bidirectional ports (Port C and Port D).</p> <p>Connector settings can be changed using SCPI and COM commands. The settings are not accessible from the front panel.</p>
PWR I/O	<p>A DB-9 female connector. Pin assignments are listed in Table 5-3 on page 5-10.</p>

Table 5-1 TEST SET I/O Connector Pin Assignments

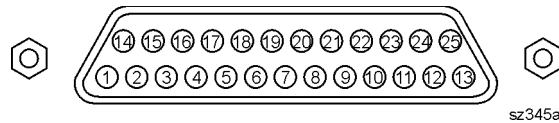

DB-25 Female Connector

Pin Numbers	Name	Function
1	SELO	TTL out, test set select bit 0, tied to 0 V
2	Sweep Holdoff In	TTL in, low level holds off sweep
3-6	AD12-AD8	TTL I/O, address and latched data
7	GND	0 V, ground reference
8	LAS	TTL out, active low address strobe (1 μ s min)
9-11	AD4-AD2	TTL I/O, address and latched data
12	GND	0 V, ground reference
13	Interrupt In	TTL in, low level (10 μ s min) aborts sweep
14	+22 V	+22 Vdc, 100 mA max.
15-16	SEL1-2	TTL out, test set select bits 1-2, tied to 0 V
17	AD11	TTL I/O, address and latched data

Table 5-1 TEST SET I/O Connector Pin Assignments

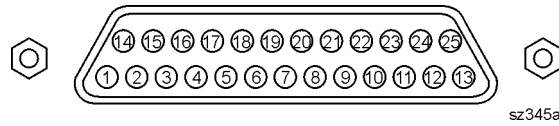

DB-25 Female Connector

Pin Numbers	Name	Function
18	SEL3	TTL out, test set select bit 3, tied to 0 V
19–21	AD7–5	TTL I/O, address and latched data
22–23	AD0–1	TTL I/O, address and latched data
24	LDS	TTL out, active low data strobe (1 μ s min)
25	RLW	TTL out, high = read, low = write

Table 5-2 HANDLER I/O Connector Pin Assignments

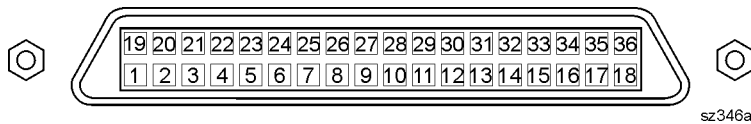

Rectangular 36-Pin Female Connector

Pin Numbers	Name	Function
1	GND	0 V, ground reference
2	INPUT1	TTL in, negative pulse (1 μ s min) latches OUTPUT1-2
3–4	OUTPUT1–2	TTL out, latched
5–12	Port A0–7 Out	TTL out, latched
13–20	Port B0–7 Out	TTL out, latched
21–24	Port C I/O	TTL I/O, latched
25–28	Port D I/O	TTL I/O, latched
29	Port C Status	TTL out, low = input mode, high = output mode
30	Port D Status	TTL out, low = input mode, high = output mode
31	Output Strobe Write Strobe	TTL out, active low data write strobe (1 μ s min)
32	No connect	Not used
33	Pass Fail	TTL out, latched, indicates pass fail (programmable polarity)

Table 5-2 HANDLER I/O Connector Pin Assignments

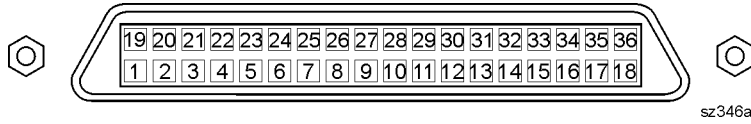

Rectangular 36-Pin Female Connector

Pin Numbers	Name	Function
34	+5 V	+5 Vdc, 100 mA max.
35	Sweep End	TTL out, active low (10 μ s min) indicates sweep done
36	Pass/Fail Write Strobe	TTL out, active low pass/fail write strobe (1 μ s min)

Table 5-3 PWR I/O Connector Pin Assignments

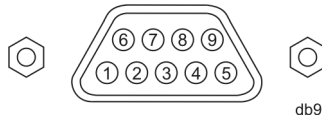

DB-9 Female Connector

Pin	Name	Description
1	+15V	+15 V @ 400 mA
2	-15V	-15 V @ 400 mA
3	AnalogOut1	Analog Output Voltage Programmable ± 10 V @ 100 mA out Nominally 0 ohms 2.44 mV typical resolution 1 MHz BW
4	AnalogOut2	Analog Output Voltage Programmable ± 10 V @ 100 mA out Nominally 0 ohms 2.44 mV typical resolution 1 MHz BW
5	ACOM	System ground
6	GndSense	Ground sense for Analog In and Analog Out Connected with 51.1 ohms to ACOM

Table 5-3 PWR I/O Connector Pin Assignments

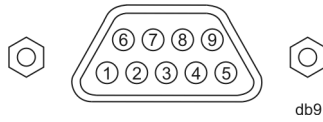

DB-9 Female Connector

Pin	Name	Description
7	AnalogIn1	Analog input: $\pm 10\text{ V @ } 1.22\text{ mV}$ typical resolution $R_{in} > 1\text{ M-ohm}$ $BW \approx 1\text{ MHz}$ ADC conversion time $< 1\text{ us}$ typical
8	AnalogIn2	Analog input: $\pm 10\text{ V @ } 1.22\text{ mV}$ typical resolution $R_{in} > 1\text{ M-ohm}$ $BW \approx 1\text{ MHz}$ ADC conversion time $< 1\text{ us}$ typical
9	Power Button	Open collector input Active low replicates power button key press.

IF Multiplexer Group Operation

The IF multiplexer group provides five rear panel IF input signals to the **Digital Processor and Digital Control Group**.

A block diagram of the IF multiplexer group is shown in **Figure 5-4 on page 5-15**.

The IF multiplexer group consists of:

- **Rear Panel IF Inputs**
- **A20 IF Multiplexer Board**

Rear Panel IF Inputs

These inputs provide the five IF input signals that are sent to the A12 SPAM board for digital processing.

A20 IF Multiplexer Board

The A20 IF multiplexer board routes the five rear panel IF input signals to the A12 SPAM board.

Figure 5-3 IF Multiplexer Group

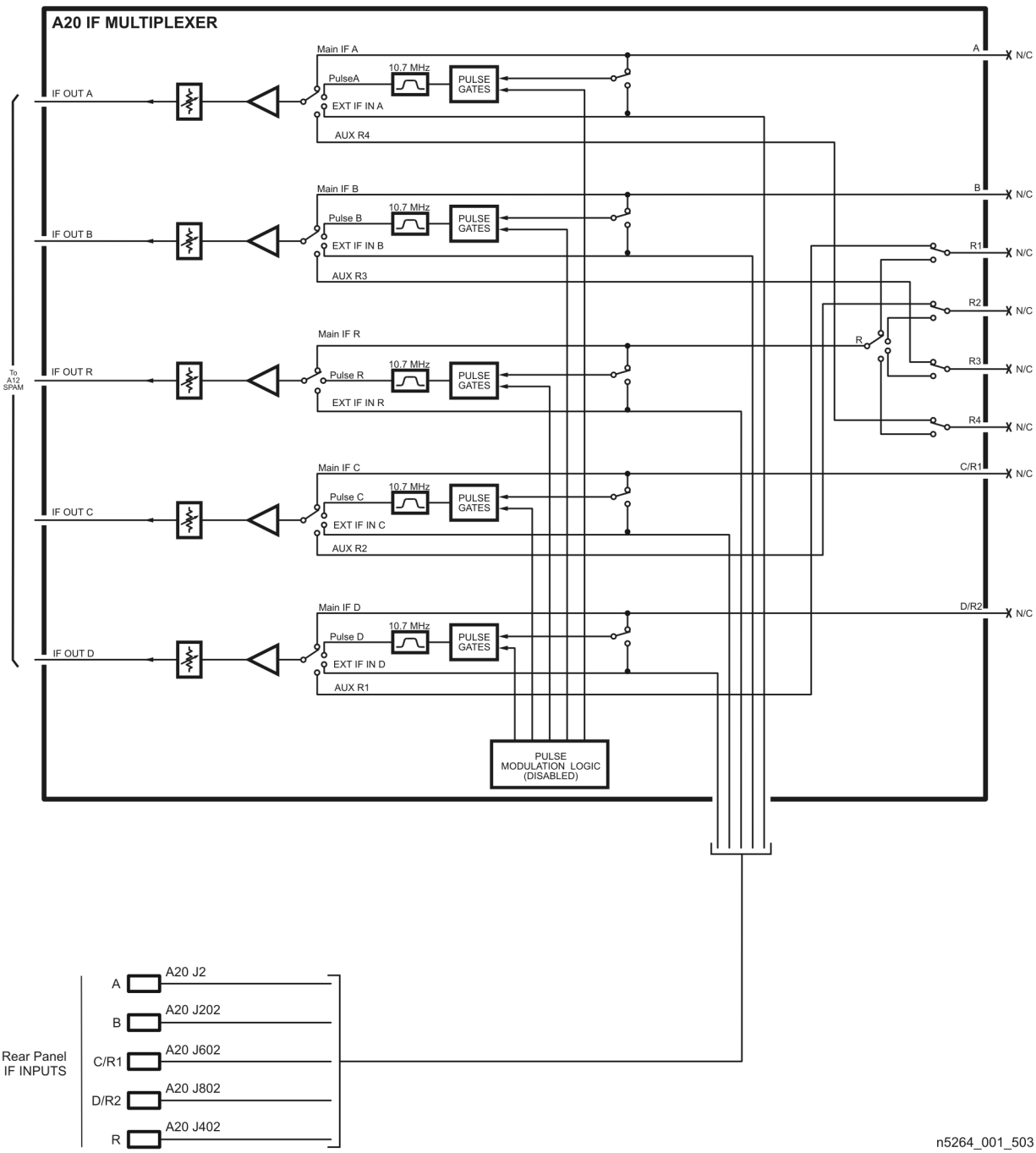

Digital Processing and Digital Control Group Operation

The digital processor and control group provides digital control for the entire analyzer. It provides:

- front panel operation,
- output to the display,
- math processing functions, and
- communications between the analyzer and an external controller or peripherals.

A block diagram of the digital control functional group is shown in **Figure 5-4 on page 5-15**.

The digital control functional group consists of two subgroups:

- **Front Panel Subgroup**
 - **A1 Front Panel Interface Board**
 - **A2 USB Board**
 - **A3 Display Assembly**
 - **Keypad Assembly**
 - A14 system motherboard
- **Data Acquisition and Processing Subgroup**
 - **A12 SPAM Board**
 - **A17 CPU Board**
 - **A51 Solid State Drive**

Figure 5-4 Digital Processing and Digital Control Group

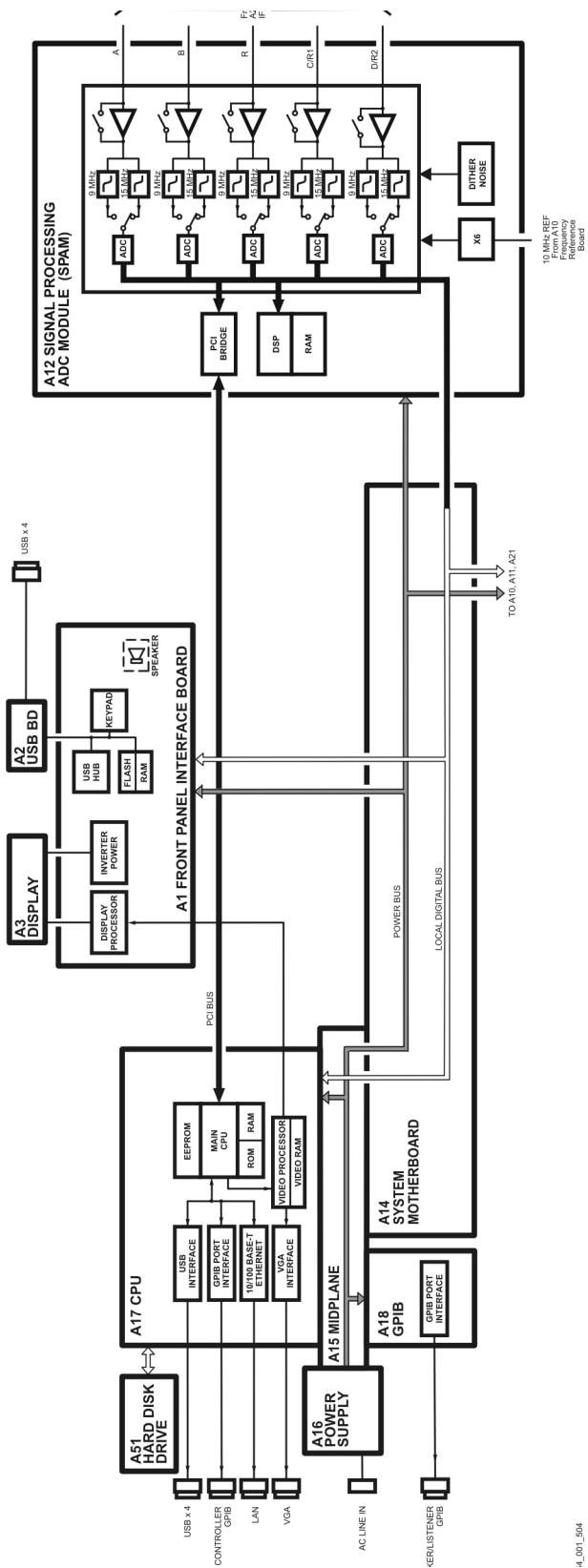

-4_001_504

Front Panel Subgroup

The front panel subgroup contains the following assemblies:

- **A1 Front Panel Interface Board**
- **A2 USB Board**
- **A3 Display Assembly**
- **Keypad Assembly**

A1 Front Panel Interface Board

The A1 front panel interface board detects and decodes user inputs from the keypad assembly and front panel knob, and transmits them to the A17 CPU board by way of the A14 system motherboard. It also decodes video data from the video processor on the A17 CPU board and supplies this to the A3 display assembly. Power from the power bus on the A14 system motherboard is buffered and routed to the keypad assembly and the A3 display assembly. All data and power signals are routed through a single cable connector to the A14 system motherboard.

The A1 front panel interface board also includes a speaker that emits the audio signals received from the A17 CPU board.

A2 USB Board

This board provides four universal serial bus (USB) jacks that are industry standard 4-pin connectors allowing multiple USB devices to be connected to the analyzer's front panel.

A3 Display Assembly

The A3 display assembly contains an 10-inch LCD with associated drive circuitry and backlight inverter. Two cables between the A3 display assembly and the A1 front panel display board provide all necessary power and data for normal operation. The two cables are:

- 1. A cable to the inverter that supplies buffered power.**
- 2. A cable to the display circuitry that supplies decoded data from the video processor on the A17 CPU board and the necessary drive circuit power.**
The video data received from the A17 CPU board includes the following:

- digital TTL horizontal sync
- digital TTL red video
- blanking
- digital TTL vertical sync
- digital TTL green video
- data clock
- digital TTL blue video

Keypad Assembly

The keypad assembly provides user interface to the analyzer. The front panel rotary pulse generator (RPG) knob is not electrically connected to the keypad, but rather provides user inputs directly to the front panel processor.

Data Acquisition and Processing Subgroup

The data acquisition and processing subgroup contain the following assemblies. See **Figure 5-4 on page 5-15**.

- **A12 SPAM Board**
- **A17 CPU Board** (including rear panel interconnects)
- **A51 Solid State Drive**

A12 SPAM Board

The digital signal processor (DSP) receives digitized data from the digital circuitry of the A12 SPAM board. It computes discrete Fourier transforms to extract the complex phase and magnitude data from the analog IF signal. The resulting raw data is written into the main random access memory (RAM). The data taking sequence is triggered either externally from the rear panel or by firmware on the A17 CPU board.

A17 CPU Board

The A17 CPU board contains the circuitry to control the operation of the analyzer. Some of the components include the central processing unit (CPU), memory (EEPROM, ROM, RAM), bus lines to other board assemblies, and connections to the rear panel. Some of the main components are described next:

- **CPU**
- **Main RAM**
- **Rear Panel Interconnects**

CPU

The central processing unit (CPU) is a microprocessor that maintains digital control over the entire instrument through the instrument bus. The CPU receives external control information from the keypad, any USB device, LAN or GPIB, and performs processing and formatting operations on the raw data in the main RAM. It controls the DSP, the video processor, and the interconnect port interfaces. In addition, when the analyzer is in the system controller mode, the CPU controls peripheral devices through the peripheral port interfaces.

Front panel settings are stored in SRAM, with a battery providing at least five years of backup storage when external power is off.

Main RAM

The main random access memory (RAM) is shared memory for the CPU and the DSP. It stores the raw data received from the DSP while additional calculations are performed on it by the CPU. The CPU reads the resulting formatted data from the main RAM, converts it to a user-definable display format, and writes this to the video processor for display.

Rear Panel Interconnects

The rear panel includes the following interfaces:

USB x4	Four universal serial bus (USB) jacks (industry standard 4-pin connectors).
GPIB (0) Controller	A 24-pin, female, type D-24 connector that meets IEEE-488 standards.
GPIB (1) Talker/Listener	A 24-pin, female, type D-24 connector that meets IEEE-488 standards.
LAN	A standard 8-pin, 10/100BaseT, Ethernet connection. It auto selects between the two data rates.
Display (VGA)	A 15-pin, female, D-sub connector that provides a video output of the analyzer display that can be viewed on an external VGA monitor.

A51 Solid State Drive

The hard disk drive assembly (SSD) is an integrated development environment (IDE) data storage device which is connected directly to, and physically mounted within the enclosure of, the A17 CPU board. The full operating system and firmware for the network analyzer is stored on the A51 hard disk drive.

Power Supply Group Operation

The A16 power supply assembly is a switching power supply operating at 103 kHz switching frequency. The input power ranges for the power supply are 90 to 132 Vac or 195 to 250 Vac. The power supply automatically senses the input voltage and switches between these two ranges.

WARNING

Supply voltages which oscillate between the two normal input ranges of the autoranging line voltage input will damage the power supply. In rare cases, this damage has become a user safety concern. If unstable power levels are expected, the analyzer input power must be buffered by a line conditioner.

The dc output voltages of the A16 power supply assembly are:

- +15 V analog
- +9 V analog
- +3.3 V analog
- +5.2 V analog
- +15 V standby (always on)
- +32 V analog
- –15 V analog
- –5.2 V analog
- –7 V analog
- +5.1 V standby
- +12 V digital
- +3.35 V digital
- +5.1 V digital

The +15 V standby supply remains on continuously whenever the power supply is plugged in. This supply is used to provide power to front panel LEDs and CPU components when the analyzer is turned off.

Theory of Operation
Power Supply Group Operation

6 Replaceable Parts

Information in This Chapter

This chapter:

- identifies the replaceable parts for the Keysight PNA-X measurement receiver.
- includes several tables and illustrations to assist you in identifying the correct part for your measurement receiver.
- contains ordering information for new assemblies and rebuilt-exchange assemblies.

Chapter Six at-a-Glance

Section Title	Summary of Content	Start Page
Ordering Information	How to order a replaceable part from Keysight Technologies.	page 6-2
Assembly Fault Identification and Replacement Sequence	The correct sequence for determining the failure of, and replacing, a defective assembly.	page 6-3
Replaceable Parts Listings	Tables that list the assemblies by reference designator with their associated part number and description. Illustrations that indicate the location of each of the replaceable parts in your measurement receiver: <ul style="list-style-type: none">– Assemblies (front panel, top, and bottom)– Cables (top and bottom)– Hardware (top, bottom, internal, external, and rear panel)– Miscellaneous replaceable parts	page 6-4

Ordering Information

To order a part listed in the replaceable parts lists:

- include the part number
- indicate the quantity required
- Contact Keysight Technologies for instructions on where to send the order.
Refer to
“Contacting Keysight” on page 2-8.

To order a part **that is not listed** in the replaceable parts lists:

- include the instrument model number and complete instrument serial number
- include the description and function of the part
- indicate the quantity required
- Contact Keysight Technologies for instructions on where to send the order.
Refer to
“Contacting Keysight” on page 2-8.

Assembly Fault Identification and Replacement Sequence

The following steps describe the procedure to identify, and then replace, a faulty assembly.

- Step 1.** Identify the faulty group. Begin with **Chapter 4, “Troubleshooting.”** Follow up with the appropriate troubleshooting chapter that identifies the faulty assembly.
- Step 2.** Order a replacement assembly. Refer to **Chapter 6, “Replaceable Parts.”** (this chapter).
- Step 3.** Replace the faulty assembly and determine what adjustments are necessary. Refer to **Chapter 7, “Repair and Replacement Procedures.”**
- Step 4.** Determine the necessary adjustments and performance tests to be performed. Refer to **Table 7-2, “Related Service Procedures,”** on page 47.
- Step 5.** Perform the necessary adjustments. Refer to **Chapter 3, “Tests and Adjustments.”**
- Step 6.** Perform the necessary performance tests. Refer to **Chapter 3, “Tests and Adjustments.”**
- Step 7.** Keysight personnel: see **Figure 1-1 on page 1-6** to review where the calibration stickers should be placed on the PNA.

Replaceable Parts Listings

This section contains the replacement part numbers and their descriptions for your Keysight microwave PNA. You can find the locations of replaceable parts in this section:

- listed by reference designator in **Table 6-1**, or
- listed by the type of part in **Table 6-2**.

Table 6-1 Part Number Location by Reference Designator

Reference Designator	Description	Location
A1	Front panel interface board	"Front Panel Assembly, Back Side, All Options" on page 6-7
A2	USB board	
A3	Display assembly	
A10	Frequency reference board	"Top Assemblies, All Options" on page 6-12
A11	13.5 GHz synthesizer board (Option 108)	
A12	Signal processing ADC module (SPAM) board	
A14	System motherboard	
A15	Midplane board	
A16	Power supply	
A17	CPU board	
A18	GPIB board	
A19	Test set motherboard	"Bottom Assemblies, All Options" on page 6-18
A20	IF multiplexer board	
A21	LO multiplier/amplifier 26.5 (HMA26.5) (Option 108)	
A51	Hard disk drive	"Top Assemblies, All Options" on page 6-12

Table 6-2 Part Number Location by Type of Part

Type of Part	Location
Assemblies	<ul style="list-style-type: none"> – "Front Panel Assembly, Front Side, All Options" on page 6-6 – "Front Panel Assembly, Back Side, All Options" on page 6-7 – "Top Assemblies, All Options" on page 6-12 – "Bottom Assemblies, All Options" on page 6-18 – "Rear Panel Assembly, All Options" on page 6-30

Table 6-2 Part Number Location by Type of Part (Continued)

Type of Part	Location
Cables	<ul style="list-style-type: none">– “Top Cables, All Options” on page 6-16– “Bottom Cables, All Options” on page 6-20
Hardware	<ul style="list-style-type: none">– “Top Hardware and Miscellaneous Parts, All Options” on page 6-22– “Bottom Hardware and Miscellaneous Parts, All Options” on page 6-24– “Internal Hardware and Miscellaneous Parts, All Options” on page 6-26– “External Hardware and Miscellaneous Parts, All Options” on page 6-28– “Rear Panel Assembly, All Options” on page 6-30
Miscellaneous	<ul style="list-style-type: none">– Service Tools on page 6-32– Documentation on page 6-32– GPIB Cables/GPIB Adapter on page 6-32– Fuses on page 6-32– ESD Supplies on page 6-33– Memory Modules on page 6-32– Upgrades Orderable by Model Number on page 6-32– USB Accessories on page 6-33– Rack Mount Kits and Handle Kits on page 6-33– Touch-up Paint on page 6-33

Front Panel Assembly, Front Side, All Options

NOTE

The N5264-60010 (Was N5264-60006) front panel assembly contains the items shown in the following table.

Reference Designator	Part Number	Qty	Description
①	N5240-20089	1	Front frame, machined, 1-piece, 2-port (frame only, not the assembly). (Requires: Lower front panel overlay. See below.)
	8160-0660	1.2 m	RFI gasket material, 1.2 meters in length (Must be ordered separately from front frame.)
②	0515-2044	12	Machine screw, M4.0 x 12 flat head (To attach front frame to chassis.)
③	5042-8434	2	With handles—front handle side trim
	5041-7908	2	Without handles—trim strip, filler
④	N5240-80040	1	Keypad overlay
⑤	N5264-80005	1	Lower front panel overlay
⑥	W1312-40180	1	Front (RPG) knob
⑦	N5264-80004	1	Nameplate
⑧	N5264-00005	1	Panel, lower dress.
⑨	N5240-40002	1	Trim, bottom, goes on the outside, underneath the Front Frame frame (①). (All PNA models)
⑩	0515-1946	10 ^a	Machine screw, M3 x 6 mm flat head (To attach lower dress panel overlay frame to chassis.)
Not shown	5023-3074	2	Front handle
Not Shown	N5242-00048	2	Guard, jumper cables, side—2-Port & 4-Port
Not Shown	N5242-00049	1	Guard, jumper cables, center—4-Port

a. Some options require 14 of the 0515-1946 screws to secure dress panel overlay subpanel.

Figure 6-1 Front Panel Assembly, Front Side, All Options

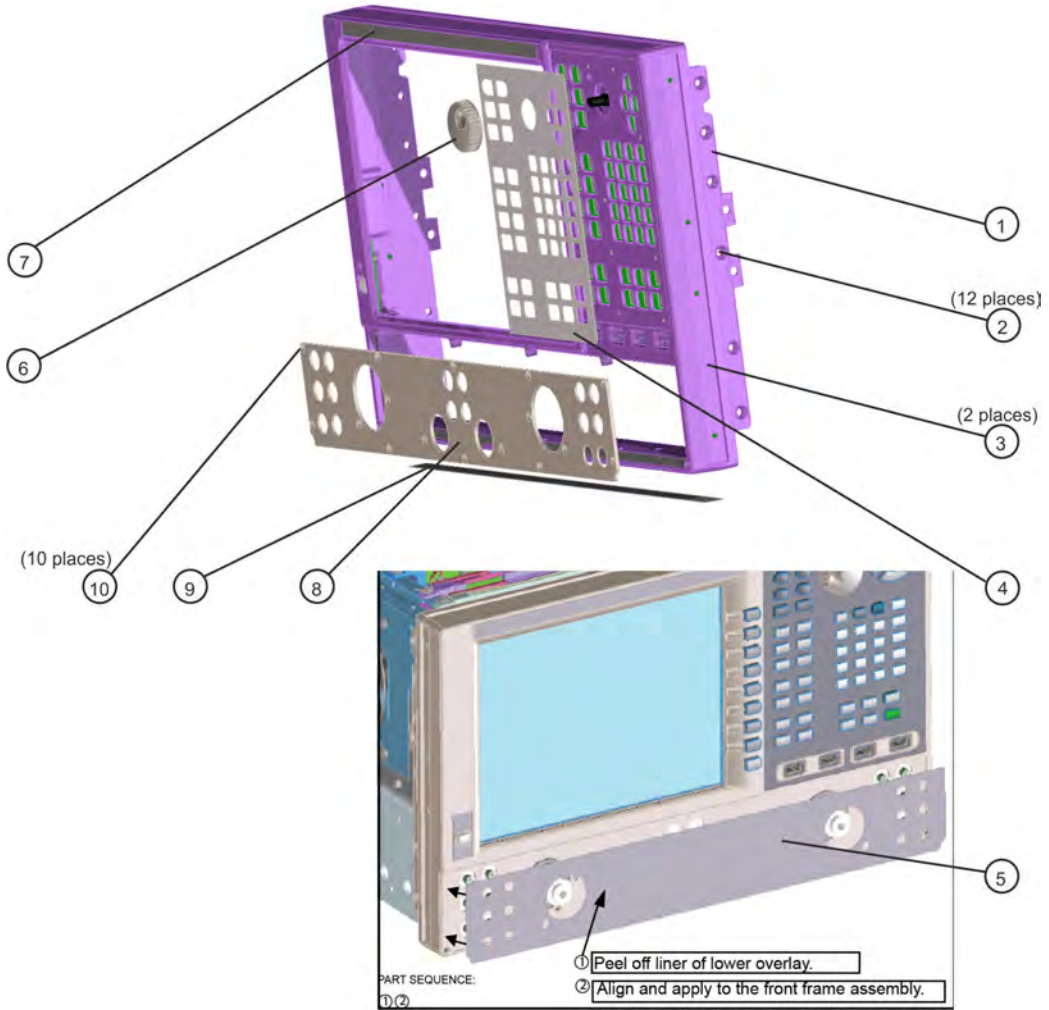

Front Panel Assembly, Back Side, All Options

Reference Designator	Part Number	Qty	Description
A1	N5240-63081	1	Front panel interface board
A2	N5240-63082	1	USB board
not shown	N5240-60090	1	Ribbon cable, 60-wire, A14 system motherboard J9 to A1 front panel interface board J1
①	N5240-40004	1	Keypad assembly

Replaceable Parts
 Replaceable Parts Listings

Reference Designator	Part Number	Qty	Description
②	0515-0430	34	Machine screw, M3.0 x 6 mm pan head (6 to attach LCD Mounting plate to LCD brackets, 3 to attach LCD cable to mounting plate, 7 to attach keypad assembly onto front frame, 5 to attach USB board to front panel interface board, 2 to attach power switch board to slot in front frame, and 11 to attach LCD assembly to front frame.)
③	0535-1157	1	Nut-Hex M9 x 2 mm (to attach RPG board)
④	2190-0016	1	Washer, RPG secure (to attach RPG board)
⑤	N5240-63083	1	RPG board.
⑥	2090-1092	1	Touch display LCD, 12.1 inch
⑦	N5242-00045 (LCD)	1	LCD Mounting plate
⑧	W1312-40016	1	Foam mount, speaker (to attach speaker assembly)
⑨	N5240-60072	1	Speaker assembly (Do NOT touch top of speaker's clear diaphragm! Attach cable to interface board J11.)
⑩	2090-1088	1	Touch screen controller board
⑪	0515-1934	6	Machine screw, M2.5 x 6 pan head (4 to attach controller board to LCD mounting plate and 2 to attach LED driver board to LCD mounting plate)
⑫	0950-5452 (LED)	1	LED Driver board (Backlight converter board)
⑬	0380-5485	2	Standoff-Hex nuts Male-Female M3 x 4.5 mm (To attach to keypad PCA)
⑭	1400-1334	2	Cable clamp (with adhesive backing)
⑮	N5240-63084	1	Power switch board (PCA for Power button keypad)
⑯	N5242-40014	1	Power button keypad
A3			Display assembly
⑰	N9912-20043	2	Tape (To secure cable E5071-61653 to 2090-1092 LCD's connector and to secure cable E5071-61653 to J8 on the interface board)
A3			Display assembly (continued from previous page)
⑱	0515-2151	4	Machine screw, M2.0 x 4mm pan head (4 -2 for each bracket - to attach LCD side bracket(s) to 2090-1092 LCD)
⑲	N5242-00046 (LCD)	2	LCD display side bracket (in Figure 6-4 on page 6-11 , only one bracket is shown.)
⑳	8121-2173	1	LCD Cable assembly 30 AWG 300V 12-pin plug to 8-pin plug
㉑	E5071-61653	1	LCD display cable

Replaceable Parts
Replaceable Parts Listings

Reference Designator	Part Number	Qty	Description
②②	N5240-60073	1	Touch screen controller board cable
②③	N5242-60075	1	Cable, A3 LED Driver board (Backlight converter board to interface board)
②④	N5242-60074	1	Power switch cable
②⑤	E5071-61660	1	Wire assembly, RPG (to attach RPG board (N5240-63083) to Interface board (J10))

Figure 6-2 Front Panel Assembly, Back Side, All Options

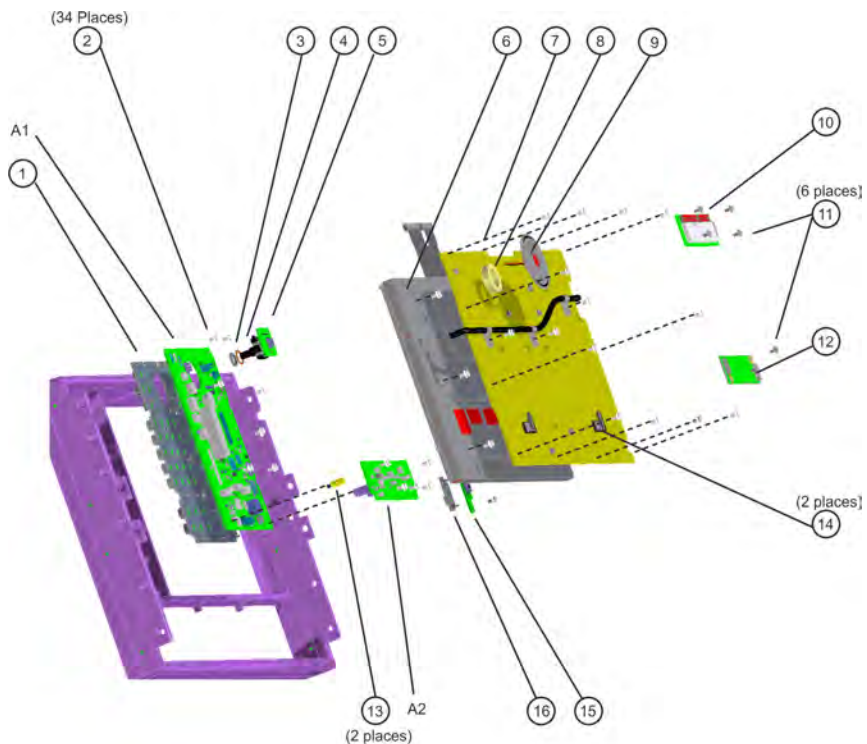

Figure 6-3 A3 Display Assembly with Interface Board/USB Assemblies

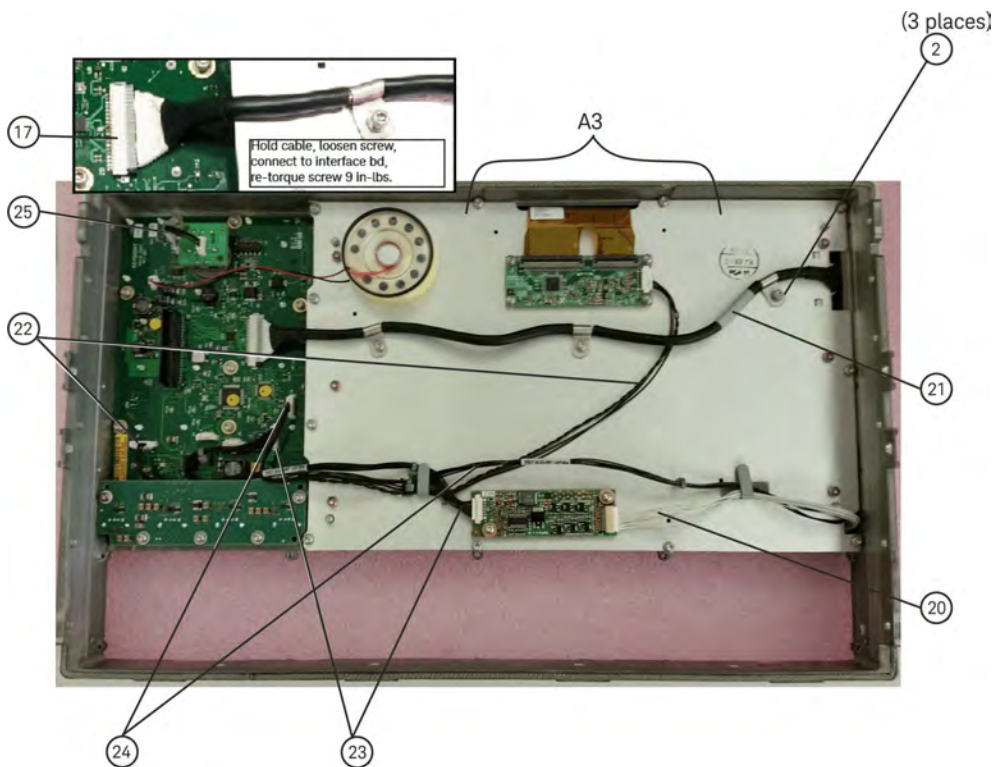
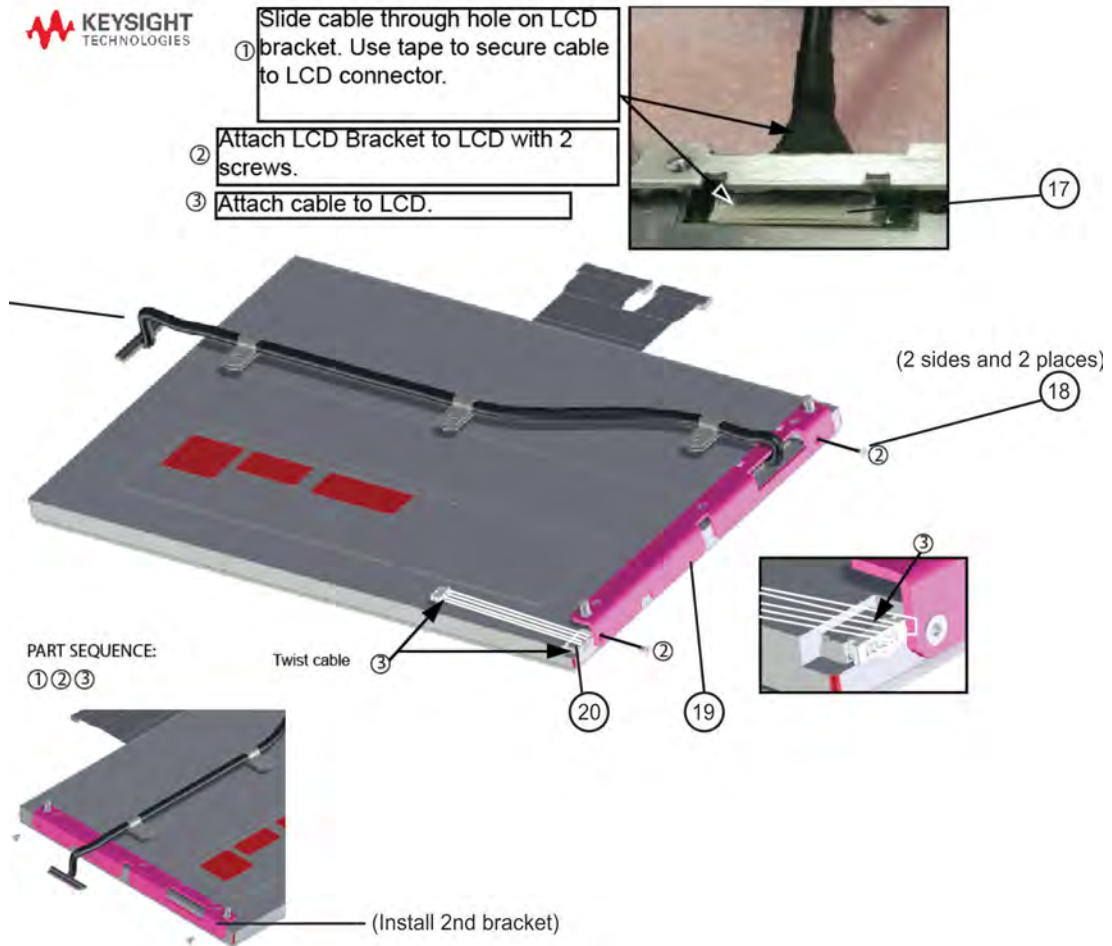

Figure 6-4 A3 Display Assembly with LCD Display 2090-1092 (LED) and Side Brackets



Top Assemblies, All Options

NOTE

When replacing an old assembly, install an assembly with either the same part number or the new part number.

NOTE

In February 2012, the N5264B analyzer underwent significant hardware changes. These changes included a redesigned Signal Processing ADC Module (SPAM) board, Frequency Reference board, left side inner bracket, and right side inner bracket. It is very important that this redesigned hardware be used only with analyzer serial numbers prefixed MY/SG/US5204 and above. If you have an analyzer whose serial number is prefixed MY/SG/US5144 and below, you must use the previous version of hardware rather than the redesigned hardware. Both versions of the affected boards are included in the following table.

Be very careful to use the appropriate hardware in your analyzer. Using the wrong hardware can ruin analyzer components, resulting in additional customer costs.

Reference Designator	Serial Number Prefixes Affected ^a	Part Number	Qty	Description
A10	5204 and above	N5240-60069	1	Frequency reference board
	5144 and below	N5240-60061 Was N5240-60042		
A11	All prefixes	N5240-60074 Was: N5230-60002	1	13.5 GHz LO synthesizer board
A12	5204 and above	N5240-60077 Was N5240-60056	1	Signal Processing ADC Module (SPAM) board
	5144 and below	N5245-60126 Was N5240-60041, or N5264-60005		
A14	All prefixes	N5242-60151 Was N5240-60044	1	System motherboard
A15	All prefixes	W1312-60095 Was W1312-60002	1	Midplane board
A16	All prefixes	0950-4934 Was 0950-4900, or 0950-4457	1	Power supply

Replaceable Parts
Replaceable Parts Listings

Reference Designator	Serial Number Prefixes Affected ^a	Part Number	Qty	Description
A17	All prefixes – Version 8	W1312-60522	1	CPU board assembly ^b
	All prefixes – Version 7	W1312-60213 Was: W1312-60211 Was: W1312-20210		
A18	All prefixes	N5240-60059 Was N5240-60052	1	GPIB board
A51 ^c	All prefixes – Version 8	N5242-60136	1	Solid state drive (SSD) for Windows 7 Operating System - to be used with the Version 8, System CPU ^d
	All prefixes – Version 7	N5242-60135		Solid state drive (SSD) for Windows 10 Operating System - to be used with the Version 7, System CPU ^d
	All prefixes – Version 7	N8985A ^e		Solid state drive (SSD) upgrade for Windows 10 Operating System - to be used with the Version 7, System CPU ^d
	All prefixes – Version 7	N5242-60134		Solid state drive (SSD) for Windows 7 Operating System - to be used with the Version 7, System CPU ^d
①	All prefixes	1420-0356	1	Battery, lithium manganese dioxide, 3V, 0.22A-hr ^f

- a. In this table, the two letters that indicate the PNA manufacturing location have been removed from each serial number prefix.
- b. For the latest information on CPUs and associated drives, visit:
<http://na.support.keysight.com/pna/hdnumbers.html>.
- c. The A51 solid state drive for the 2.2 GHz CPU board plugs into the A17 CPU board assembly from the rear panel. Refer to **“Removing and Replacing the A51 Solid State Drive (SSD)” on page 7-39** for an illustration.
- d. You can learn your System CPU version using the PNA software. On the PNA front panel, press **Help > About Network Analyzer**. In the window displayed, find “System CPU Version.”
- e. For more information on the N8985A SSD, refer to the Windows 10 Operating System Upgrade Kit Installation Note, available online at <https://www.keysight.com/us/en/assets/9018-04733/installation-guides/9018-04733.pdf> (N8985-90001).
- f. The lithium battery is located inside the A17 CPU board assembly. Refer to **“Removing and Replacing the Lithium Battery” on page 7-45** for an illustration.

Figure 6-5 Top Assemblies, All Options

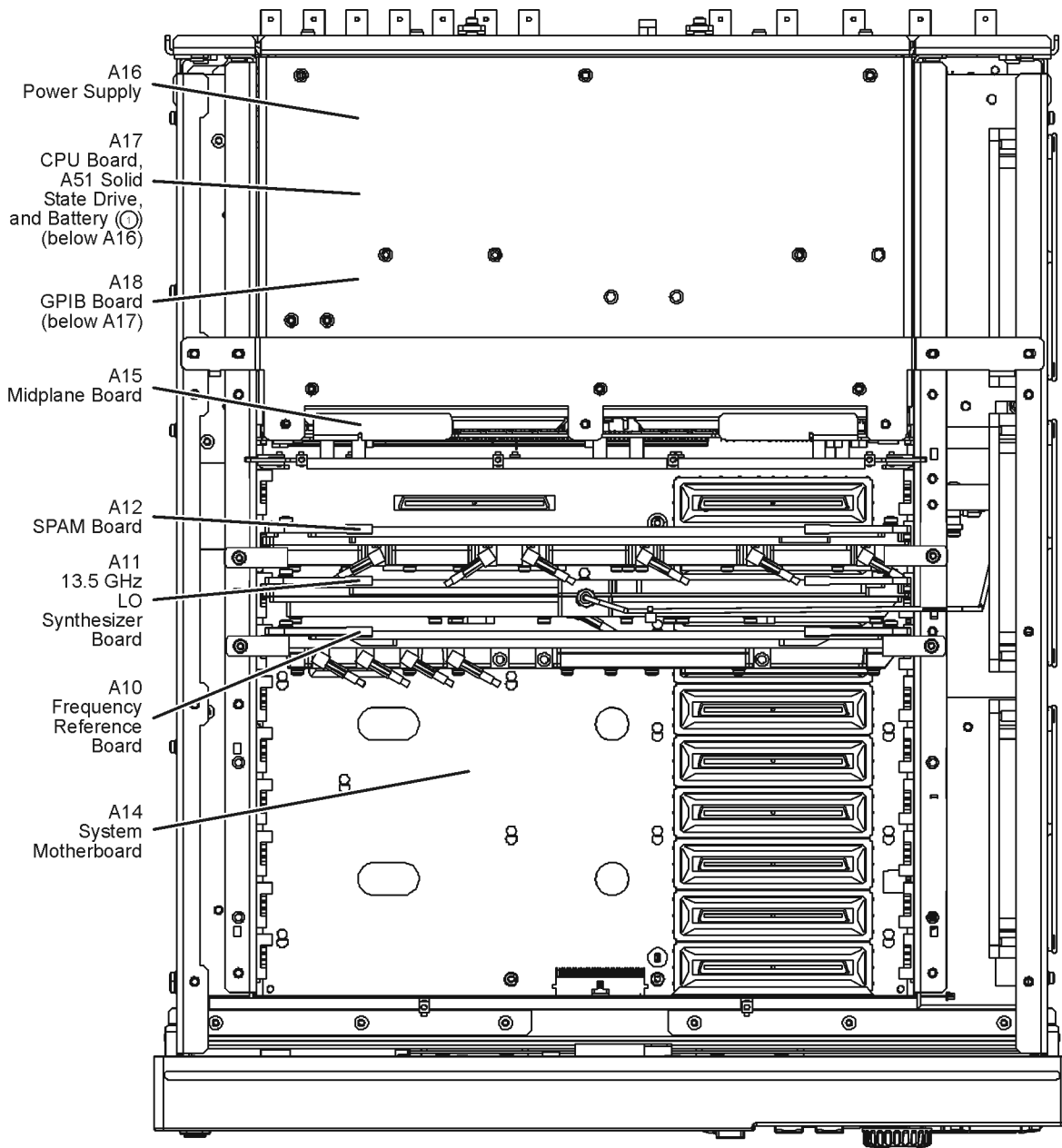

Replaceable Parts
Replaceable Parts Listings

This page is intentionally left blank.

Replaceable Parts
Replaceable Parts Listings

Top Cables, All Options

Reference Designator	Type ^a	Part Number	Qty	Description
W41	SR	N5242-20110	1	A11 13.5 GHz (LO) synthesizer board J1207 to A21 HMA26.5
W59	F	N5242-60012	1	A20 IF multiplexer board P3 to A12 SPAM board J1
W60	F	N5242-60013	1	A20 IF multiplexer board P203 to A12 SPAM board J2
W61	F	N5242-60014	1	A20 IF multiplexer board P403 to A12 SPAM board J4
W62	F	N5242-60015	1	A20 IF multiplexer board P603 to A12 SPAM board J5
W63	F	N5242-60016	1	A20 IF multiplexer board P803 to A12 SPAM board J6
W64	F	N5242-60027	1	A10 frequency reference board J4 to A12 SPAM board J3
W65	F	N5242-60028	1	A10 frequency reference board J5 to A11 13.5 GHz (LO) synthesizer board J5
W68	F	8120-5063	2	Rear-panel 10 MHz REF IN to A10 frequency reference board J2
W69				A10 frequency reference board J3 to rear-panel 10 MHz REF OUT

a. SR = semirigid coaxial cable; F = flexible coaxial cable

Figure 6-6 Top Cables, All Options

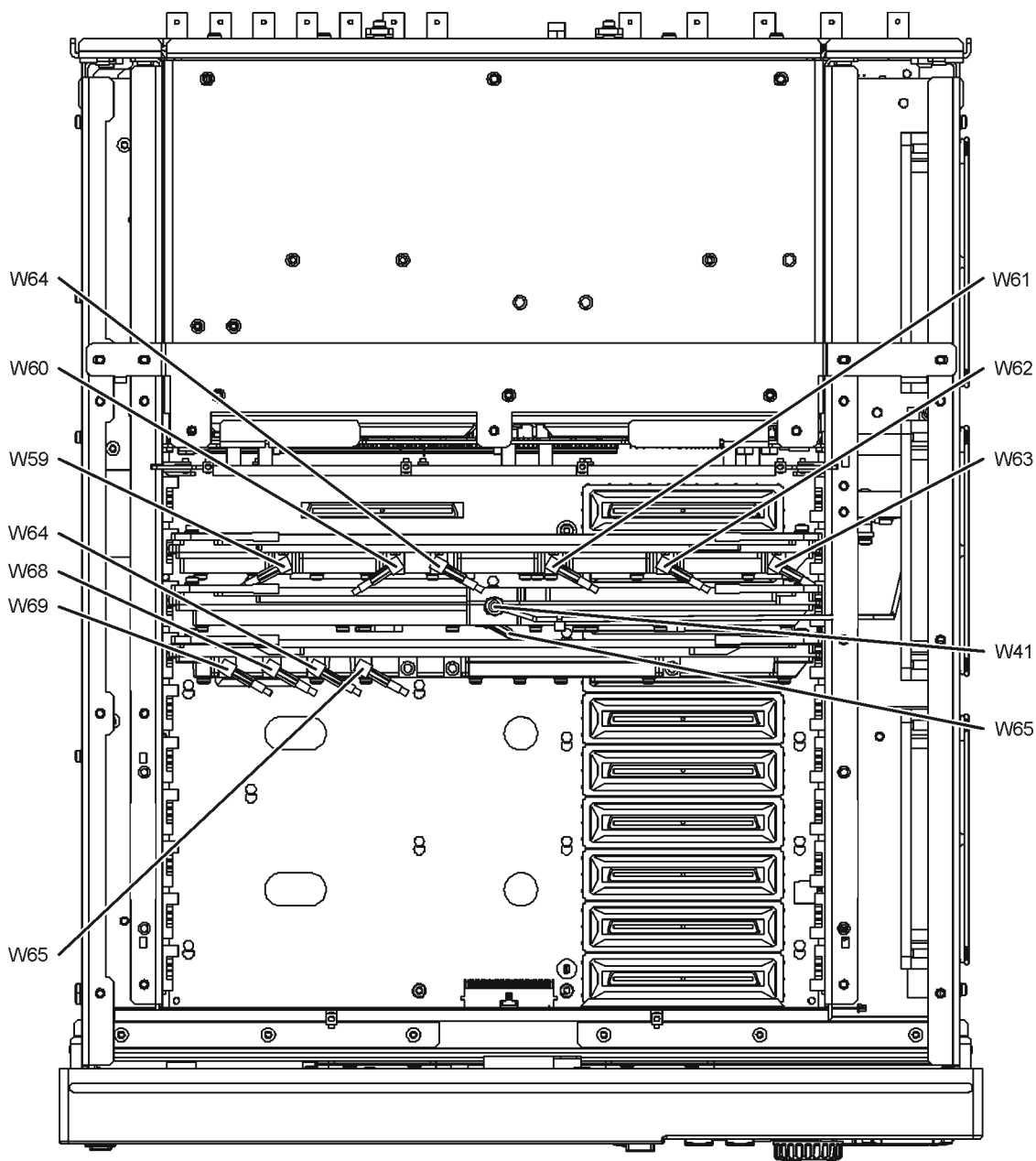

n5264_001_603

Replaceable Parts
Replaceable Parts Listings

Bottom Assemblies, All Options

Reference Designator	Part Number	Qty	Description
A19	N5245-60163 Was N5245-60003 or N5240-60043	1	Test set motherboard
A20	N5240-60062 ^a Was N5240-60045	1	IF multiplexer board
A21	5087-7765 Was 5087-7711	1	LO Multiplier/amplifier 26.5 (HMA26.5) (Option 108)

- a. All new units built after August 2009, no longer use the N5242-60031 cable that was attached to connector P1001 and Source 2. As a result of this change, the IF multiplexer boards have had their P1001 connectors removed. If your instrument contains a N5242-60031 cable, remove it from your instrument.

Figure 6-7 Bottom Assemblies, All Options

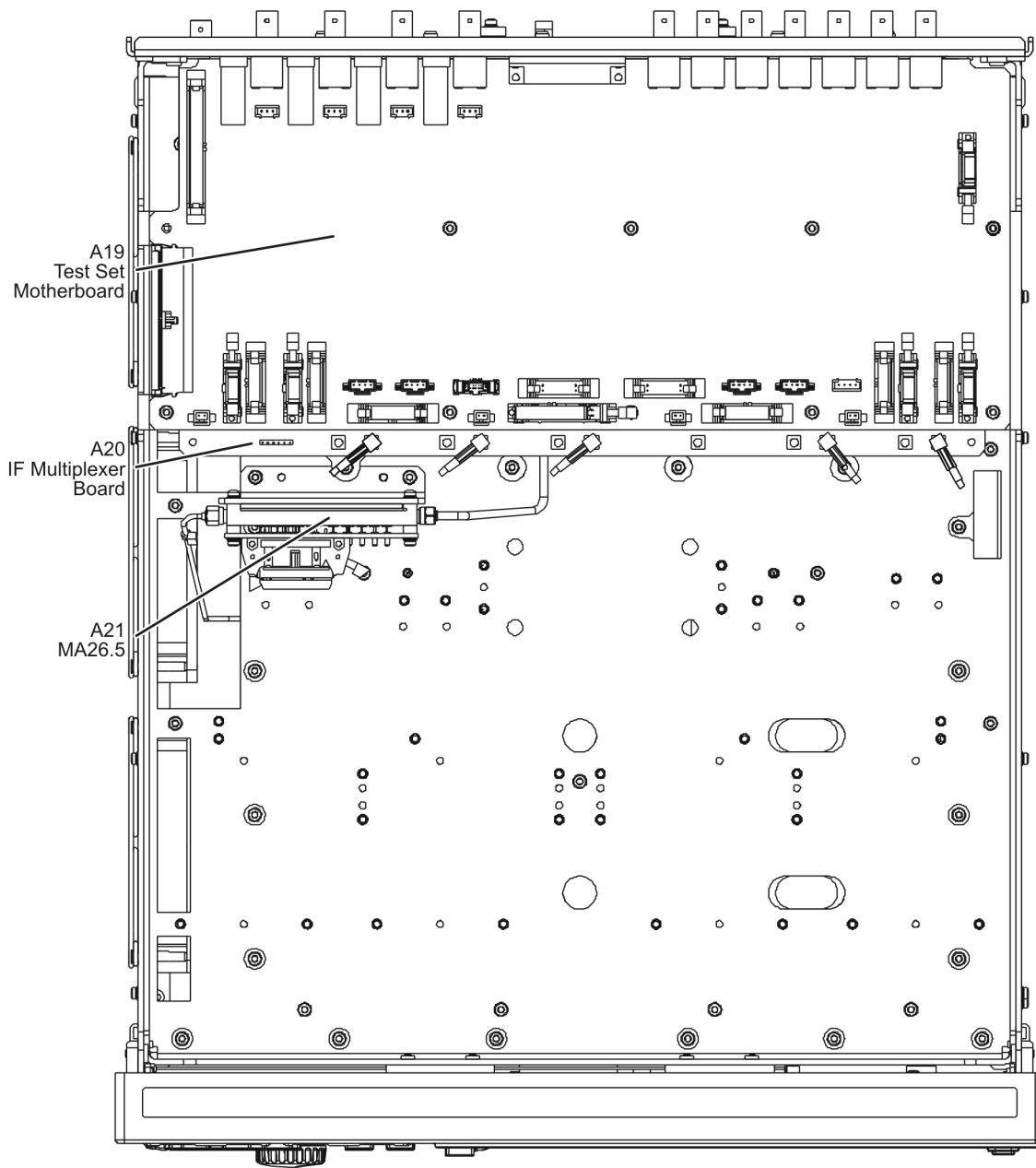

n5264_001_604

Replaceable Parts
 Replaceable Parts Listings

Bottom Cables, All Options

Reference Designator	Type ^a	Part Number	Qty	Description
W41	SR	N5242-20110	1	A11 13.5 GHz synthesizer to A21 HMA26.5
W47	SR	N5264-20002	1	A21 HMA26.5 to rear-panel LO OUT (J5)
W59	F	N5242-60012	1	A20 IF multiplexer (P3) to A12 SPAM (J1)
W60	F	N5242-60013	1	A20 IF multiplexer (P203) to A12 SPAM (J2)
W61	F	N5242-60014	1	A20 IF multiplexer (P403) to A12 SPAM (J4)
W62	F	N5242-60015	1	A20 IF multiplexer (P603) to A12 SPAM (J5)
W63	F	N5242-60016	1	A20 IF multiplexer (P803) to A12 SPAM (J6)
①	10R	N5242-60005	1	Rear-panel PWR I/O to A19 test set motherboard J301
②	24R	N5230-60014 Was N5242-60011	1	A19 test set motherboard J209 to A21 HMA26.5
③	100R	N5242-60004	1	A14 system motherboard J1 to A19 test set motherboard J1 to A20 IF multiplexer board J1
④	36R	8121-0834	1	Rear-panel HANDLER I/O to A19 test set motherboard J400

a. SR = semirigid coaxial cable; F = flexible coaxial cable; nR = n wires in a ribbon (flat) cable

Figure 6-8 Bottom Cables, All Options

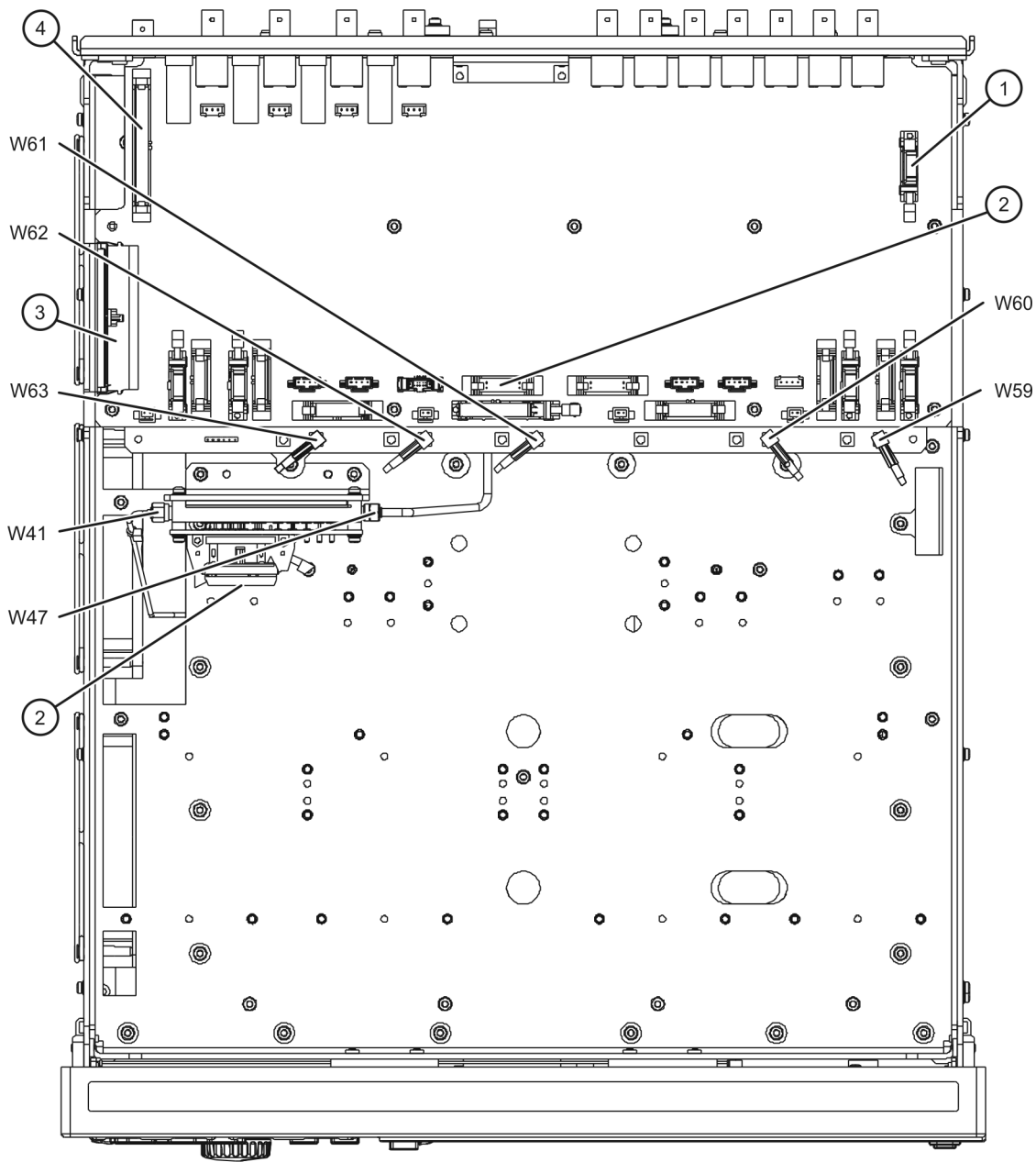

n5264_001_605

Top Hardware and Miscellaneous Parts, All Options

Reference Designator	Part Number	Qty	Description
B1	3160-4199	3	Fan
①	3160-0281 Was 3160-4198	3	Fan guard
②	0361-1272	12	Fan rivet
③	N5242-00015	1	Fan bracket
④	0515-0372	12	Machine screw, M3.0 x 8, pan head (5 to attach fan bracket to chassis, 4 to attach power supply bracket to inner panels, left side bracket, and fan bracket, and 3 to attach A14 system motherboard to the chassis.)
n	Chassis (Refer to “Internal Hardware and Miscellaneous Parts, All Options” on page 6-26.)		
⑥	0515-1227	3	Machine screw, M3.0 x 6, flat head (To attach power supply bracket to power supply.)
⑦	W1312-00062	1	Power supply bracket
⑧	0515-0375	6	Machine screw, M3.0 x 16, pan head (To attach midplane board to midplane bracket.)
⑨	0400-0353	5	Midplane board grommets

Figure 6-9 Top Hardware and Miscellaneous Parts, Side View, All Options

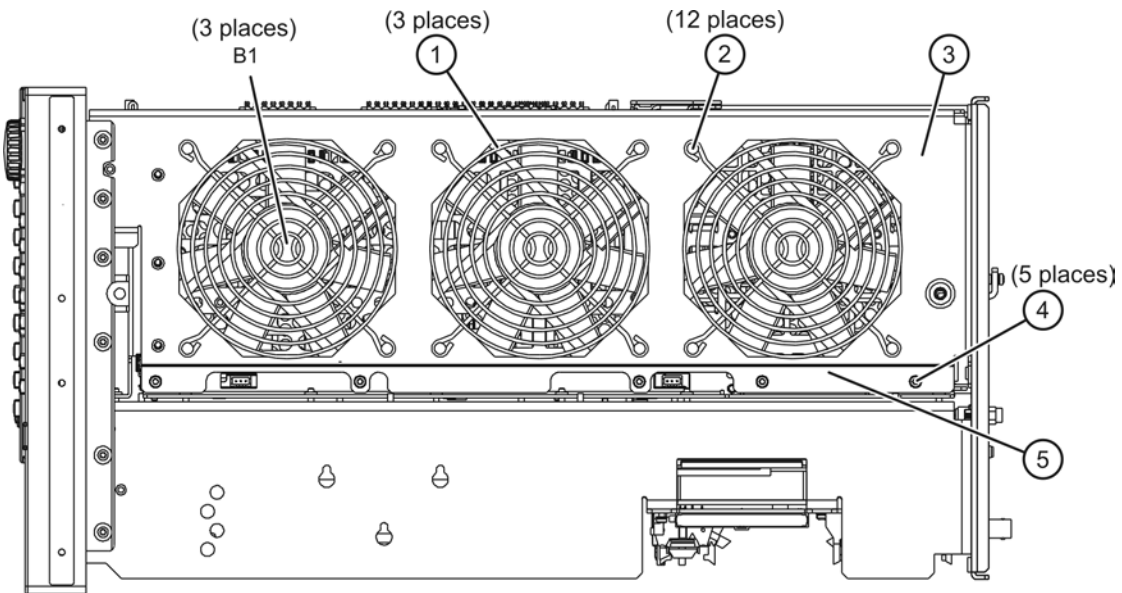

n5264_001_606-1

Figure 6-10 Top Hardware and Miscellaneous Parts, Top View, All Options

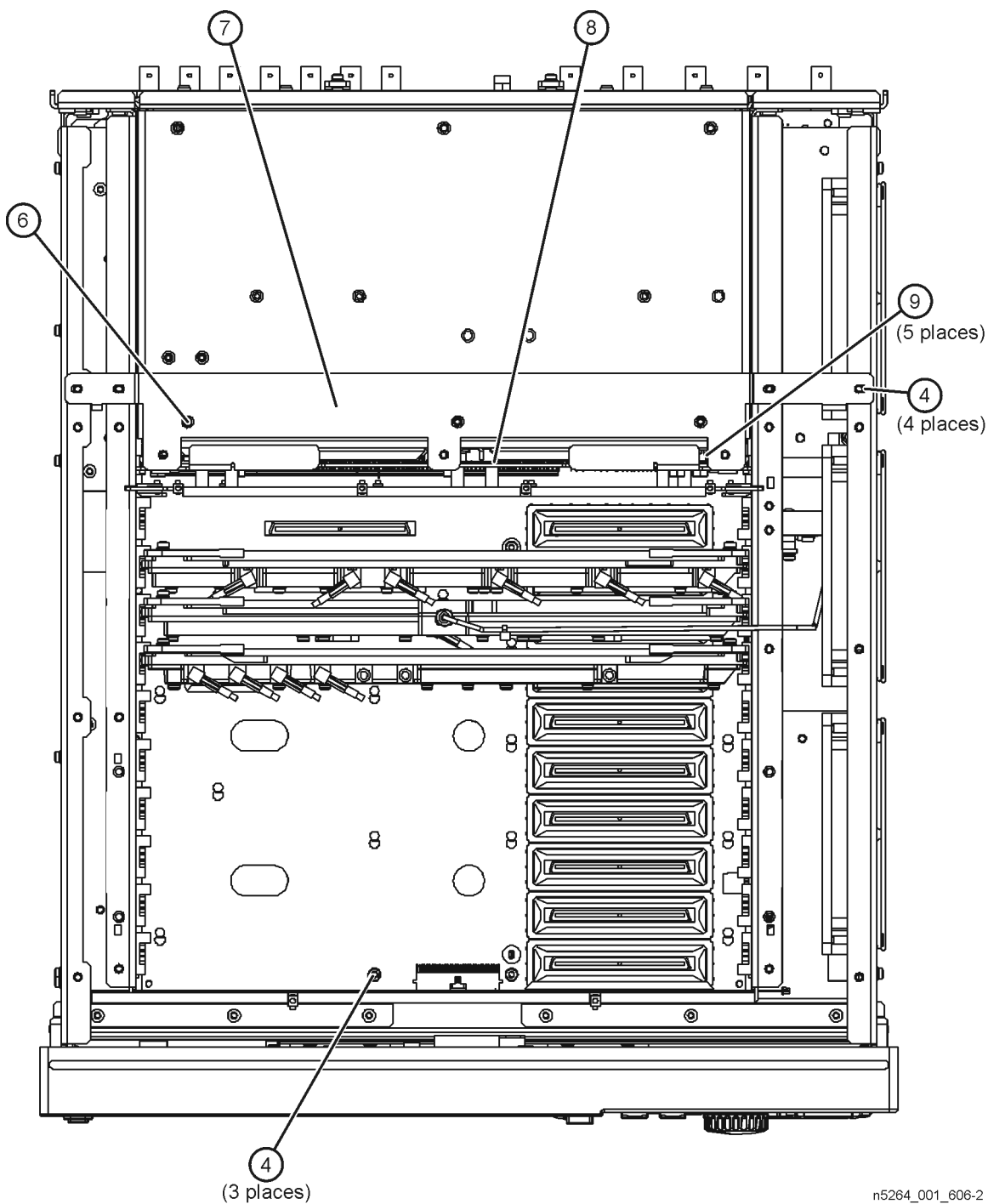

n5264_001_606-2

Replaceable Parts
 Replaceable Parts Listings

Bottom Hardware and Miscellaneous Parts, All Options

Reference Designator	Part Number	Qty	Description
①	0515-0372	39	Machine screw, M3.0 x 8, pan head (4 to attach A19 test set motherboard to test set deck, 6 to attach A19 test set motherboard to stabilizer bracket, 4 to attach stabilizer bracket to A20 IF mux board, 17 to attach test set deck to chassis, 4 to attach A21 HMA26.5 to its mounting bracket, and 4 to attach test set front sub panel to front of test set deck.)
②	0515-0430	2	Machine screw M3.0 x 6 pan head to attach HMA26.5 bracket to test set deck.)
③	N5235-00018	1	Bracket (For ribbon cable clamp)
④	N5242-00005	1	Bracket (For A21 HMA26.5.)
n	N5242-00019	1	Stabilizer bracket (Between A19 test set motherboard and A20 IF mux board.)
⑥	1250-4261 Was: 1810-0118	2	Termination, 50-ohm load
⑦	N5221-00006 Was N5242-00018	1	Test set front sub panel
⑧	0515-1227	4	Machine screw M3.0 x 6 flat head (to attach test set front sub panel to front of side brackets.)
⑨	N5221-00005 Was N5242-00002	1	Test set deck

Figure 6-11 Bottom Hardware and Miscellaneous Parts, All Options

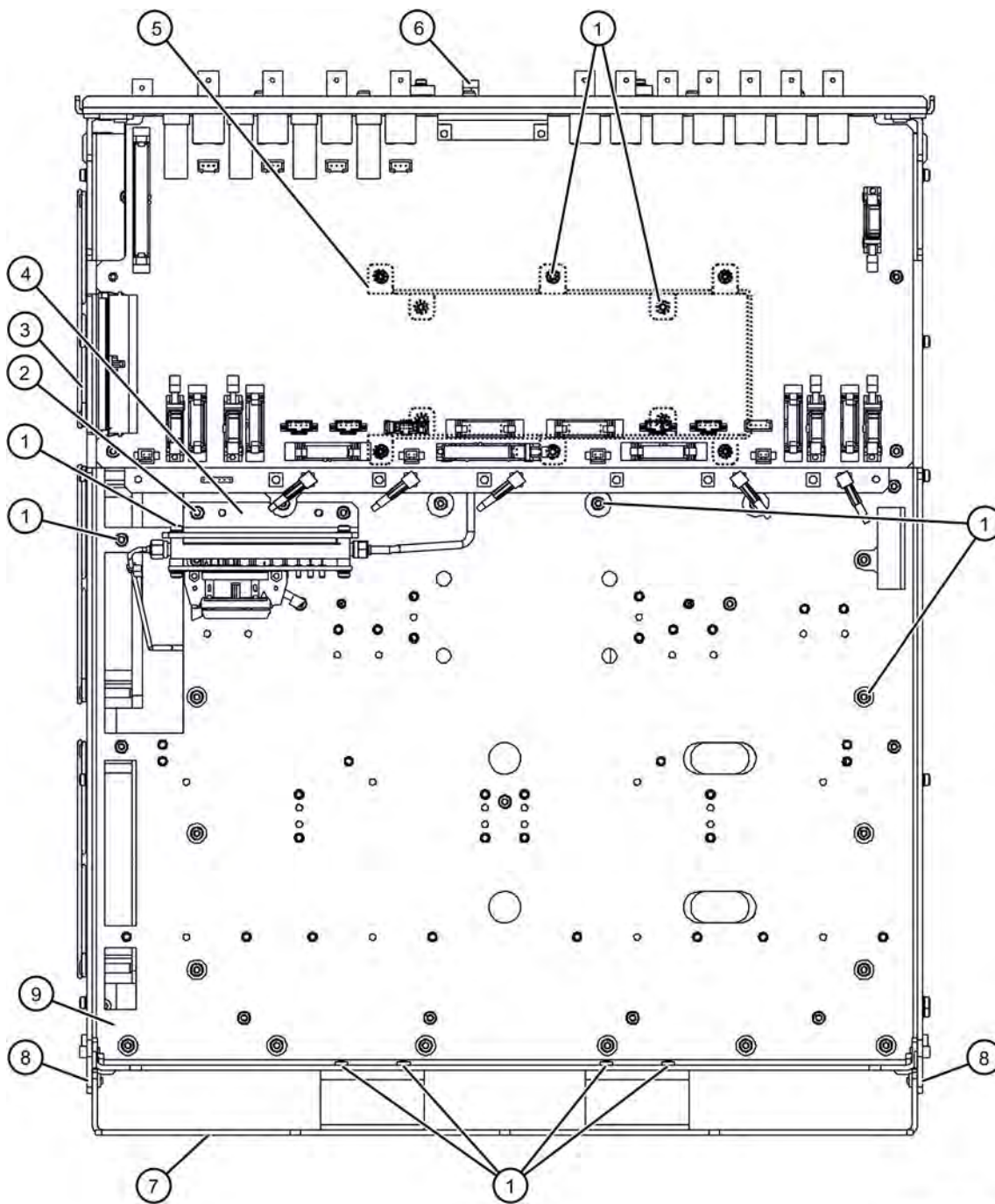

n5264_001_607

Replaceable Parts
 Replaceable Parts Listings

Internal Hardware and Miscellaneous Parts, All Options

Reference Designator	Serial Number Prefixes Affected ^a	Part Number	Qty	Description
①	5204 and above	N5221-00003	1	Left side inner bracket
	5144 and below	W1312-00051		
②	All prefixes	W1312-00048	1	Midplane bracket
③	5204 and above	N5221-00002	1	Right side inner bracket
	5144 and below	N5242-00033		
④	All prefixes	N5242-00001	1	Chassis
⑤	All prefixes	0515-0372	39	Machine screw, M3.0 x 8, pan head (4 to attach midplane bracket to left and right side inner brackets, 6 to attach front bracket to left and right side inner brackets, 2 to attach side bracket to front bracket, 5 to attach side bracket to chassis, 22 to attach chassis to left and right side inner brackets, midplane bracket, and front bracket.)
⑥	All prefixes	N5242-00017	1	Front bracket
⑦	All prefixes	N5242-40002	16	PC board guides
⑧	All prefixes	N5242-00016	1	Side bracket (left)

a. In this table, the two letters that indicate the PNA manufacturing location have been removed from each serial number prefix.

Figure 6-12

Internal Hardware and Miscellaneous Parts, All Options

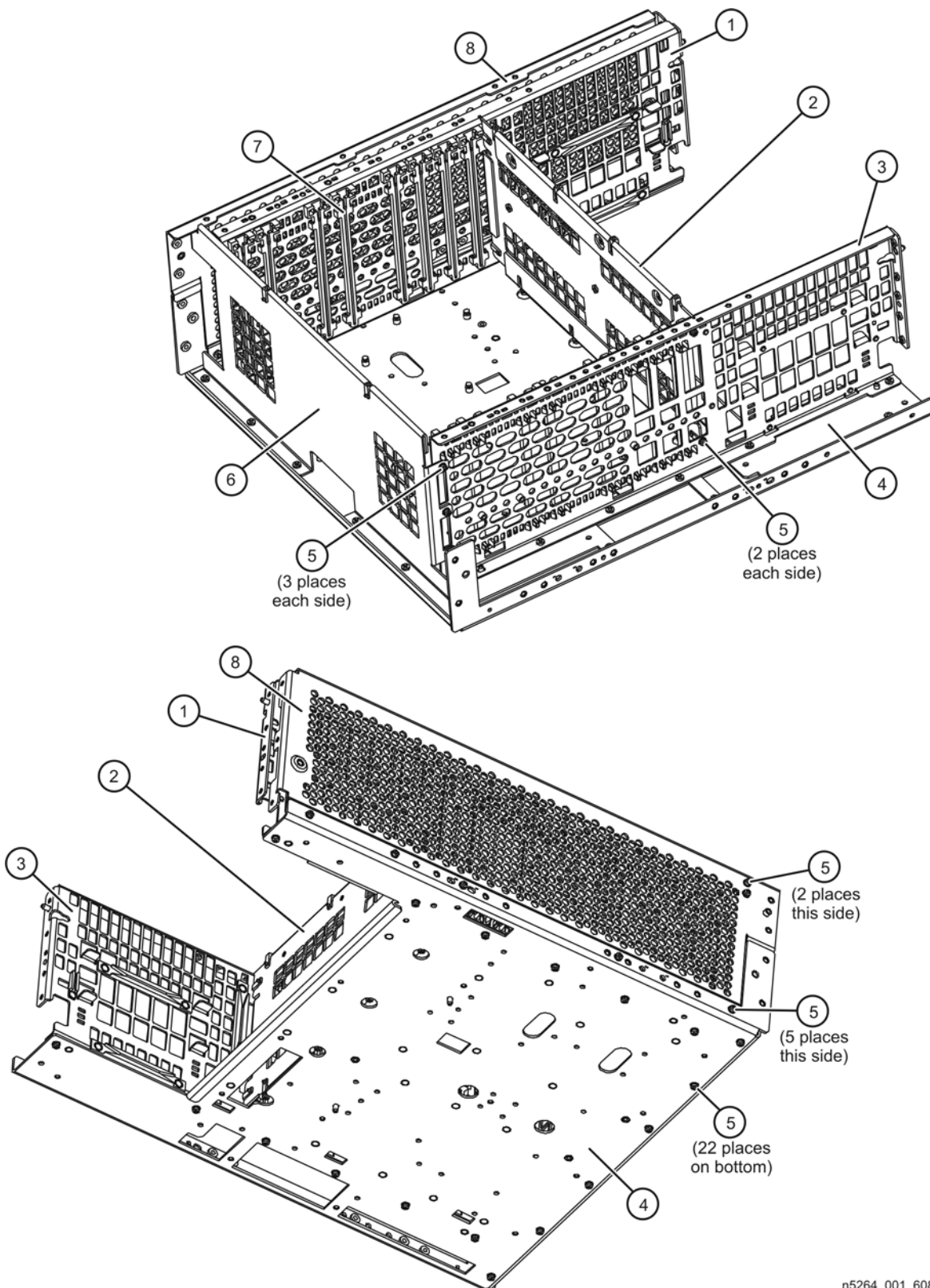

n5264_001_608

Replaceable Parts
 Replaceable Parts Listings

External Hardware and Miscellaneous Parts, All Options

Reference Designator	Part Number	Qty	Description
①	N5242-00047	1	Outer cover
②	5041-7903	4	Rear foot
③	0515-1619	4	Machine screw M4.0 x 25, pan head (To attach rear foot.)
④	N5242-60076	2	Strap handle assembly (Includes item ⑤)
n	0515-0710	4	Machine screw M5.0 x 18, flat head (To attach strap handle.)
⑥	5021-2840	4	Key lock (for bottom foot)
⑦	5041-7906	4	Bottom foot
	W1312-40032	4	Hole plug (When instrument is rack mounted.)
⑧	0515-0372	12	Machine screw, M3.0 x 8, pan head (To attach inner cover.)
⑨	N5221-00001 Was N5264-00003	1	Inner cover (retaining shield)
⑩	0515-1227	9	Machine screw, M3.0 x 6, flat head (To attach inner cover.)
Not shown	N9040-40007	1	Front impact cover
Not shown	N9040-40008	1	Rear impact cover

Figure 6-13 External Hardware and Miscellaneous Parts, All Options

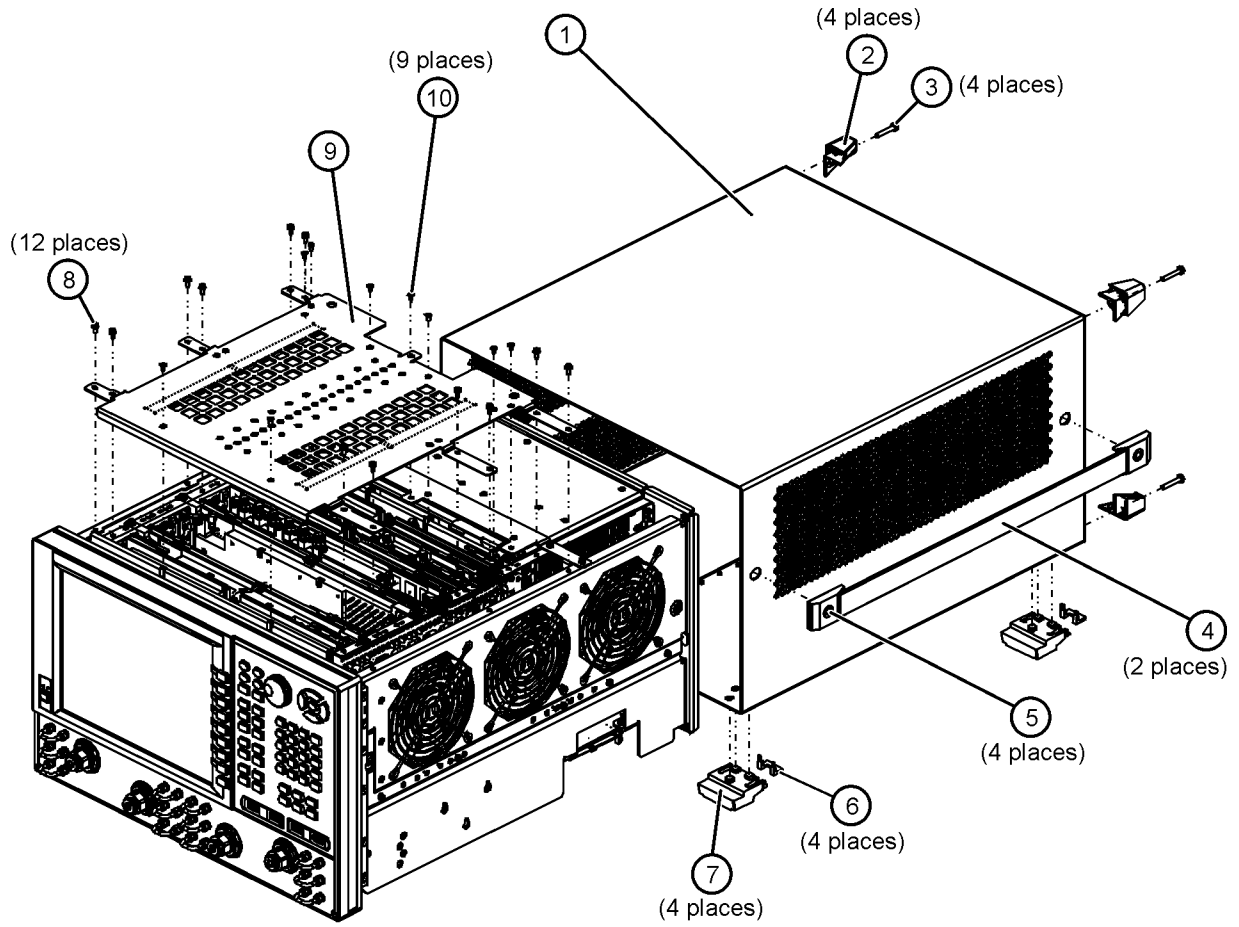

n5264_001_609

Replaceable Parts
Replaceable Parts Listings

Rear Panel Assembly, All Options

Item Number	Part Number	Qty	Description
①	N5240-00012	1	Power supply rear panel
②	0515-0372	28	Machine screw, M3.0 x 8, pan head
③	Rear foot and screw (Refer to “External Hardware and Miscellaneous Parts, All Options” on page 6-28.)		
④	6960-0149	1	Hole plug
n	N5242-00010	1	Rear panel
⑥	2190-0958 Was 2190-0034	--	Lock washer
⑦	0380-0644	--	Jack screw
⑧	2190-0584	--	Lock washer
⑨	0380-4670 Was 1251-7812	--	Jack screw, 0.442 inch length
	1251-7812	--	Jack screw, 0.5 inch length
⑩	N5242-60005	1	PWR I/O cable assembly
⑪	1250-4261 Was: 1810-0118	1	Termination, 50 ohm load
⑫	8121-0834	1	HANDLER I/O cable assembly
⑬	2190-0068	--	Lock washer
⑭	2950-0054	--	Hex nut
⑮	Bottom foot (Refer to “External Hardware and Miscellaneous Parts, All Options” on page 6-28.)		
⑯	6960-0076	10	Hole plug
⑰	2190-0102	--	Lock washer
⑱	2950-0035	--	Hex nut

Figure 6-14 Rear Panel Assembly, All Options

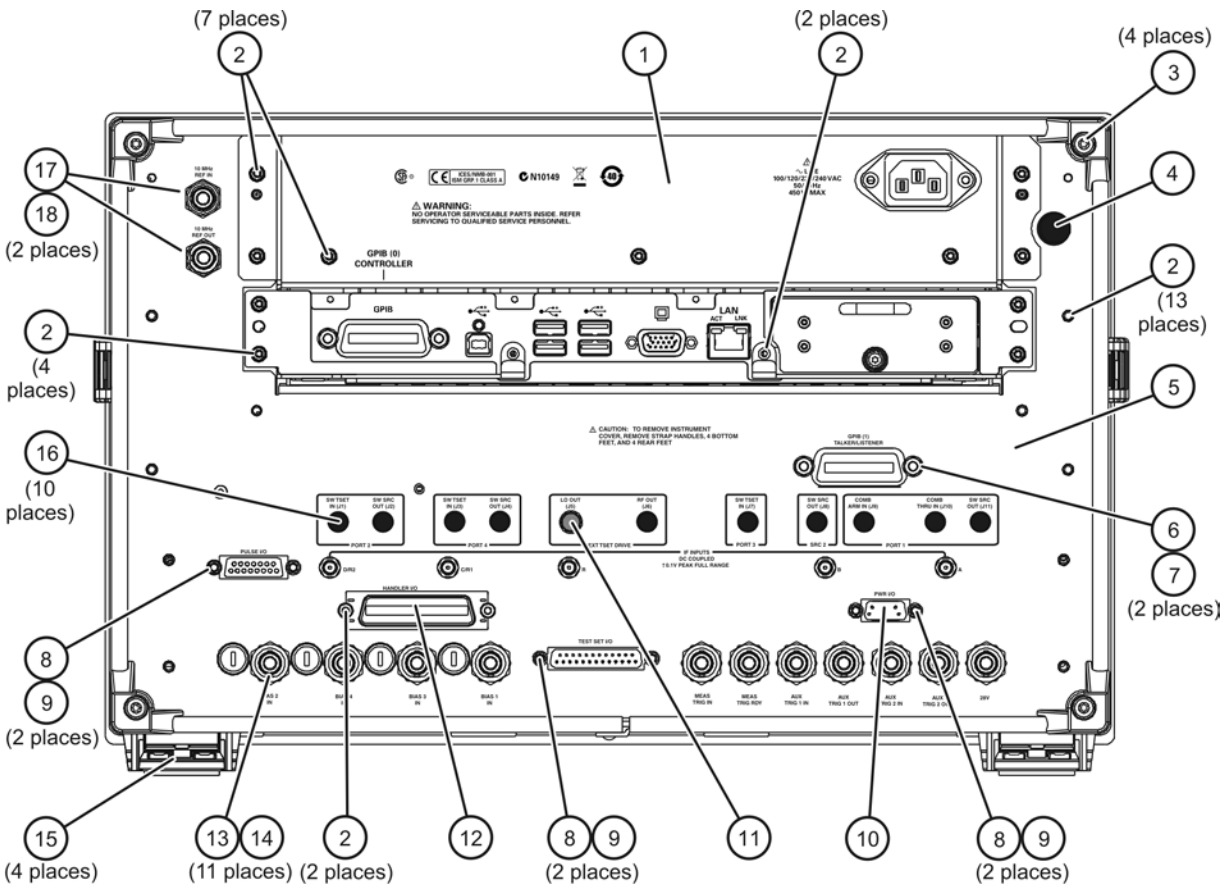

n5264_001_610

Miscellaneous Part Numbers

Table 6-3 Part Numbers for Miscellaneous Parts and Accessories

Description	Model or Part Number
Service Tools	
T-10 TORX driver (set to 9 in-lbs)	N/A
T-20 TORX driver (set to 21 in-lbs)	N/A
Pozidriv screwdriver	N/A
5/16 inch (8 mm), open-end torque wrench; 0.9 N-m (8 in-lb)	8710-1765
Documentation	
Installation and Quick Start Guide (for all PNA series analyzers) (Cannot be ordered. Part number is for reference only. Must be printed from the Keysight Web site.)	E8356-90001
Service Guide. (Not available in printed form. Part number is for reference only. Must be printed from the Keysight Web site.)	N5264-90001
GPIB Cables/GPIB Adapter	
GPIB cable, 0.5 meter (1.6 feet)	10833D
GPIB cable, 1 meter (3.3 feet)	10833A
GPIB cable, 2 meter (6.6 feet)	10833B
GPIB cable, 4 meter (13.2 feet)	10833C
GPIB cable to GPIB cable adapter	10834A
Fuses	
Rear Panel Bias Input Fuse; Ports 1, 2, 3, and 4 (0.5 A, 125 V)	2110-0824 Was 2110-0046
Memory Modules	
1 GB module, DDR SDRAM, 166 MHz, 184-pin	1819-0329
Battery	
Battery, lithium manganese dioxide, 3V, 0.22A-hr (located on A17 CPU board assembly)	1420-0356
Upgrade Kits orderable by Part Number	
Add Option 010, Time Domain	--
Add Option 108, LO Source	N5264-60101
Add Option 118, Fast CW Mode	--
Upgrades Orderable by Model Number	

Table 6-3 Part Numbers for Miscellaneous Parts and Accessories (Continued)

Description	Model or Part Number
Time Domain (Option 010)	N5264BU-010
LO Source (Option 108)	N5264BU-108
Fast CW Mode (Option 118)	N5264BU-118
USB Accessories	
Mouse, optical	0960-3248 Was 1150-7799
Keyboard (U.S. style)	0960-3245 Was 1150-7896
USB to GPIB adapter	82357B
ESD Supplies	
Adjustable antistatic wrist strap	9300-1367
Antistatic wrist strap grounding cord (5 foot length)	9300-0980
Static control table mat and earth ground wire	9300-0797
ESD heel strap	9300-1126
Rack Mount Kits and Handle Kits	
Rack mount kit for analyzers without handles (Option 1CM)	N5231AU-1CM or N5232AU-1CM or N5239AU-1CM
Option 1CM includes the following separately orderable items:	
Rack mount kit (rack mount flanges and hardware)	1CM042A Was 5063-9217
Rack mount rail set	E3663AC
Rack mount kit for analyzers with handles (Option 1CP)	N5231AU-1CP or N5232AU-1CP or N5239AU-1CP
Option 1CP includes the following separately orderable items:	
Rack mount kit (rack mount flanges and hardware)	5063-9237
Rack mount rail set	E3663AC
Front handle kit (two classic ^a handles and hardware)	5063-9230
Touch-up Paint	

Table 6-3 Part Numbers for Miscellaneous Parts and Accessories (Continued)

Description	Model or Part Number
Phantom gray (for use on frame around front panel and painted portion of handles and for use on rack mount flanges, rack support flanges, and front panels)	6010-3330
Titanium (for use on cover)	6010-3329

- a. For rack mount use, you must replace factory installed ruggedized handles (thick aluminum, no trim) with classic handles (thin aluminum with plastic trim), included with Option 1CP.

7 Repair and Replacement Procedures

Information in This Chapter

This chapter contains procedures for removing and replacing the major assemblies of your Keysight Technologies PNA-X measurement receiver.

Chapter Seven at-a-Glance

Section Title	Summary of Content	Start Page
Personal Safety Warnings	Warnings and cautions pertaining to personal safety.	page 7-2
Electrostatic Discharge (ESD) Protection	Information pertaining to ESD protection.	page 7-3
Table of Removal and Replacement Procedures	A table of removal and replacement procedures and the corresponding page number where they are located.	page 7-4
Removal and Replacement Procedures	The actual procedures for removing and replacing the major assemblies in your measurement receiver. The procedures occur in assembly reference designator numerical order.	See Table 7-1 on page 7-4 for specific procedures.
Post-Repair Procedures	A table for the proper tests, verifications, and adjustments to perform on your measurement receiver after repair.	page 7-47

CAUTION

The PNA contains extremely sensitive components that can be ruined if mishandled. Follow instructions carefully when making cable connections, especially wire harness connections.

The person performing the work accepts responsibility for the full cost of the repair or replacement of damaged components.

Personal Safety Warnings

WARNING

These servicing instructions are for use by qualified personnel only. To avoid electrical shock, do not perform any servicing unless you are qualified to do so.

WARNING

The opening of covers or removal of parts is likely to expose dangerous voltages. Disconnect the instrument from all voltage sources while it is being opened.

WARNING

Procedures described in this document may be performed with power supplied to the product while protective covers are removed. Energy available at many points may, if contacted, result in personal injury.

WARNING

The power cord is connected to internal capacitors that may remain live for 10 seconds after disconnecting the plug from its power supply assembly. Wait at least 10 seconds, after disconnecting the plug, before removing the covers.

WARNING

The detachable power cord is the instrument disconnecting device. It disconnects the mains circuits from the mains supply before other parts of the instrument. The front panel switch is only a standby switch and is not a LINE switch (disconnecting device).

WARNING

Danger of explosion if battery is incorrectly replaced. Replace only with the same or equivalent type recommended. Discard used batteries according to manufacturer's instructions.

Electrostatic Discharge (ESD) Protection

CAUTION

Many of the assemblies in this instrument are very susceptible to damage from electrostatic discharge (ESD). Perform the following procedures only at a static-safe workstation and wear a grounded wrist strap.

This is important. If not properly protected against, electrostatic discharge can seriously damage your measurement receiver, resulting in costly repair.

To reduce the chance of electrostatic discharge, follow all of the recommendations outlined in “[Electrostatic Discharge Protection](#)” on [page 1-7](#), for all of the procedures in this chapter.

Removal and Replacement Procedures

Table 7-1 List of Procedures

Reference Designator	Assembly Description	Location
N/A	Covers, outer and inner	page 7-5
N/A	Fan bracket and fans	page 7-43
N/A	Front panel assembly	page 7-7
N/A	Front panel LED boards	
A1	Front panel display board	page 7-9
A2	USB board	
A3	Display assembly	
A10	Frequency reference board	page 7-17
A11	13.5 GHz LO synthesizer board (Option 108)	
A12	Signal processing ADC module (SPAM) board	
A14	System motherboard	page 7-21
A15	Midplane board	page 7-24
A16	Power supply	page 7-26
A17	CPU board	page 7-28
A18	GPIB board	page 7-30
A19	Test set motherboard	page 7-32
A20	IF multiplexer board	page 7-35
A21	Multiplier/amplifier 26.5 (HMA26.5) (Option 108)	page 7-37
A51	Solid state drive	page 7-39

Removing the Covers

Tools Required

- T-10 TORX driver (set to 9 in-lb)
- T-20 TORX driver (set to 21 in-lb)

Removing the Outer Cover

CAUTION

Do not place the instrument on its front panel. This will damage the front panel assemblies.

Refer to **Figure 7-1** for this procedure.

1. Disconnect the power cord.
2. Remove the strap handles (item ①) by loosening the screws (item ②), with a T-20 TORX driver, on both ends until the handle is free of the measurement receiver.
3. Remove the foot locks (item ③) from the four bottom feet (item ④) and then remove the four bottom feet from the outer cover.
4. Remove the four rear panel feet (item ⑤) by removing the center screws (item ⑥) with a T-20 TORX driver.
5. Slide the outer cover toward the rear of the measurement receiver and remove it.

Removing the Inner Cover

Refer to **Figure 7-1** for this procedure.

1. With a T-10 TORX driver, remove the 12 pan head screws (item ⑦).
2. With a T-10 TORX driver, remove the 9 flat head screws (item ⑧).
3. Lift off the cover.

Replacement Procedure

1. On the top side of the PNA, carefully position the gray flex cables so they can't be pinched between the covers and the rails.
2. On the bottom side of the PNA, carefully fold or push down the ribbon cables and wires so they can't be pinched between the hardware and the outer cover. Ribbon cables and wires must never be positioned on top of hardware.
3. Reverse the order of the removal procedures above.

Figure 7-1 Outer and Inner Cover Removal

Outer Cover Removal

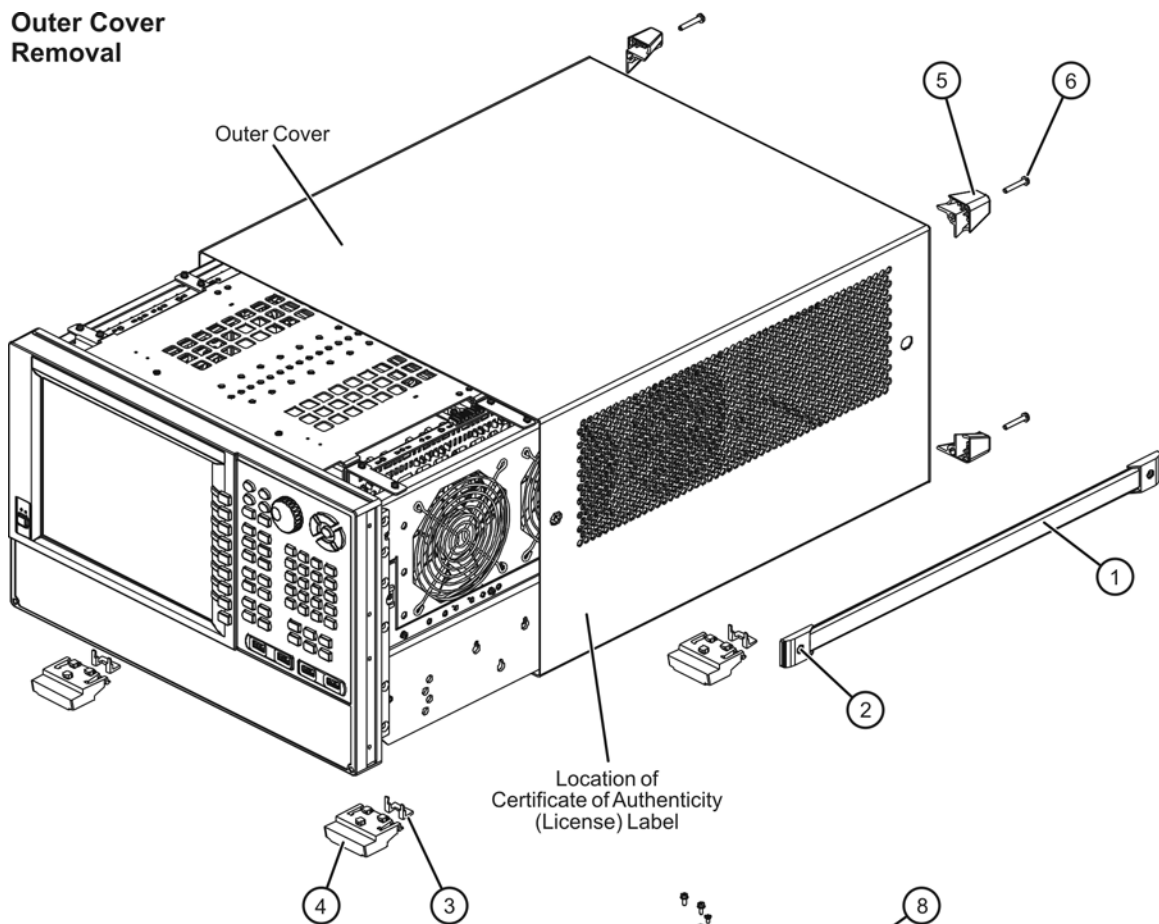

Inner Cover Removal

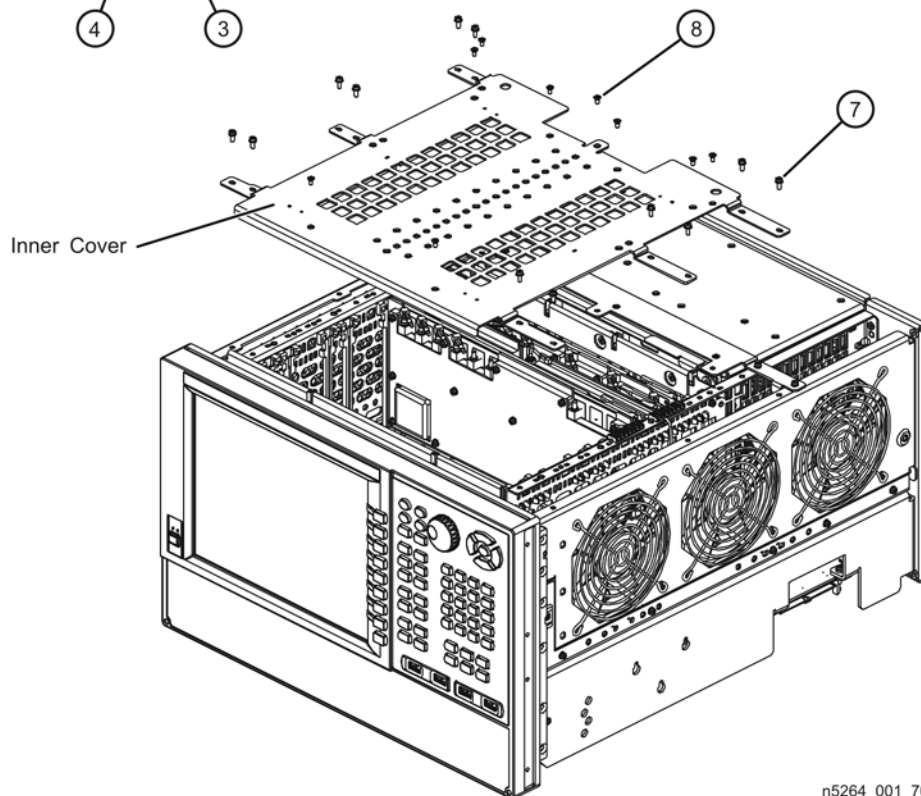

n5264_001_701

Removing and Replacing the Front Panel Assembly

Tools Required

- T-10 TORX driver (set to 9 in-lb)
- T-20 TORX driver (set to 21 in-lb)
- 5/16 inch open-end torque wrench (set to 10 in-lb)
- ESD grounding wrist strap

Removal Procedure

Refer to [Figure 7-2 on page 7-8](#) for this procedure.

1. Disconnect the power cord.
2. Remove the outer cover. Refer to [“Removing the Covers” on page 7-5](#).
3. With a 5/16 inch torque wrench, remove all the semi-rigid jumpers (item ①) from the front panel.
4. With a T-10 TORX driver, remove the 12 screws (item ②) from the sides of the frame.
5. Remove the lower panel overlay.
6. With a T-10 TORX, remove the 2 screws (2-Port) or 4 screws (4-Port).

CAUTION

Before removing the front panel from the analyzer, lift and support the front of the analyzer frame.

7. Slide the front panel over the test port connectors.
8. Disconnect the ribbon cable (item ③) from the A1 front panel interface board.

Replacement Procedure

NOTE

When reconnecting the front-panel jumpers, torque the connectors to 10 in-lb.

1. Reverse the order of the removal procedure.
2. Perform the post-repair adjustments, verifications, and performance tests that pertain to this removal procedure. Refer to [Table 7-2 on page 7-47](#).

Figure 7-2 Front Panel Assembly Removal

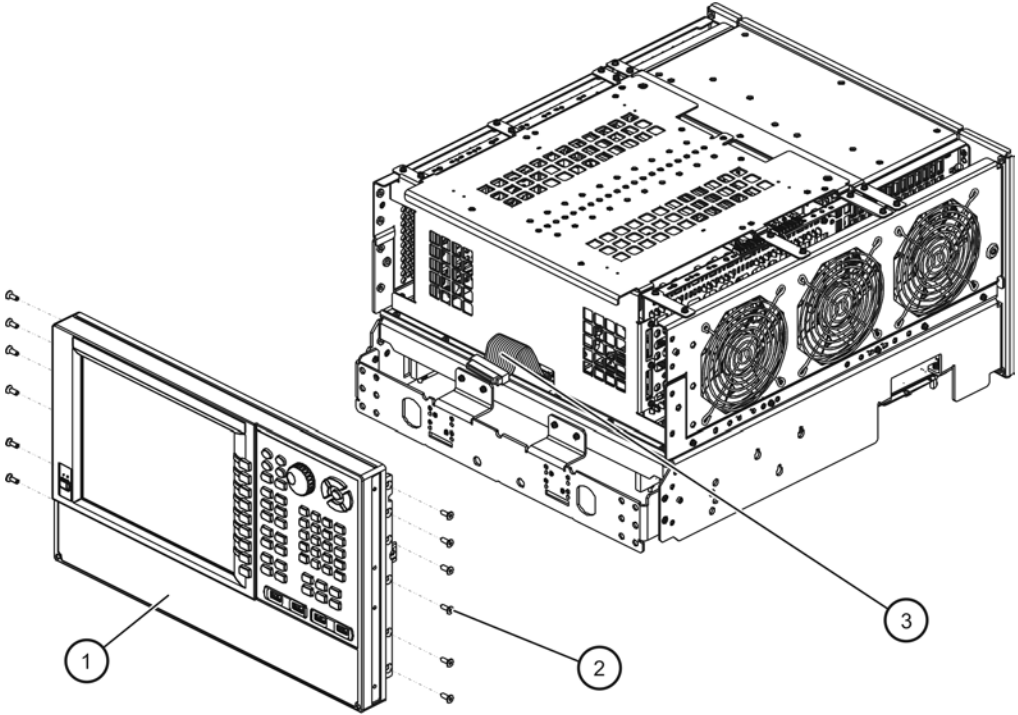

n5264_001_702

Removing and Replacing the A1–A3 and Other Front Panel Subassemblies

Tools Required

- T-6 TORX driver (set to 3 in-lb)
- T-8 TORX driver (set to 8 in-lb)
- T-10 TORX driver (set to 9 in-lb)
- T-20 TORX driver (set to 21 in-lb)
- 5/16 inch open-end torque wrench (set to 9 in-lb)
- 5/16 inch open-end torque wrench (set to 10 in-lb)
- 11 mm socket wrench (set to 9 in-lb)
- ESD grounding wrist strap

Refer to [Figure 7-3 on page 7-12](#), [Figure 7-4 on page 7-13](#), [Figure 7-5 on page 7-13](#), [Figure 7-6 on page 7-14](#), [Figure 7-7 on page 7-14](#), and [Figure 7-8 on page 7-15](#) for the following procedures.

Pre-removal Procedure

1. Disconnect the power cord.
2. Remove the front panel assembly. Refer to [“Removing and Replacing the Front Panel Assembly” on page 7-7](#).

Removing the RPG Assembly

1. Remove the round knob (RPG) from the front panel by gently pulling the knob forward.
2. Disconnect the RPG to Interface board cable (item [24]).
3. With the 11 mm socket wrench, remove the RPG board’s washer and hex nut.
4. Remove RPG assembly from the interface board.

Removing the A2 USB Board

1. Remove the five retaining screws (item ②) from the USB board and unplug it from the A1 front panel interface board.

Removing the A1 Front Panel Interface Board and Keypad Assembly

1. Remove the A2 USB board as outlined above.
2. Remove the RPG assembly as outlined above.
3. Disconnect the following cables from the A1 front panel interface board: tape (item [14]) from connector and the LCD display to interface board cable (item [18]), LED driver board (backlight converter board) to interface

board (item [11]), touch screen controller board to interface board cable (item [13]), power switch board to interface board cable (item [12]), and the speaker assembly cable.

4. Remove the seven screws (item ⑨) from the keypad/board and the two standoff-hex nuts (item ①) from the keypad/board assembly and remove it from the front panel assembly.
5. The keypad assembly can now be removed from the A1 front panel interface board by gently pulling each of the rubber tabs through the PC board.

Removing the LED Driver Inverter Board

1. Disconnect the LED driver inverter board to interface board cable connection (item [11]) and the LCD display cable (item [19]) from the LED driver inverter board.
2. Remove two screws (item ⑩) and remove the LED driver inverter board.

Removing the Touchscreen Controller Board

1. Disconnect the touchscreen controller board cable (item [13]) from the touchscreen controller board and front panel interface board.
2. Raise the retaining clamps on the LCD display flat flex cable's two connectors (item [15]).
3. Disconnect the flat flex cable from the touchscreen (item [15]).
4. With the T-8 TORX, remove the 4 screws (item ④) on the touchscreen controller board.
5. Remove the touchscreen controller board from the mounting plate.

Removing the Power Switch Board and Power Button Keypad

1. Disconnect the following cables from the A1 front panel interface board: tape (item [14]) from connector and the LCD display to interface board cable (item [18]), LED driver board (backlight converter board) to interface board (item [11]), touch screen controller board to interface board cable (item [13]), power switch board to interface board cable (item [12]), and the speaker assembly cable.
2. With the T-10 TORX, remove the eleven outer screws on the LCD mounting plate (item ⑤) and remove the A3 display assembly from the front panel assembly.
3. Disconnect the power switch cable (item [13]) from the power switch board.
4. Remove two screws (item ③) and remove the power switch board.
5. The power button keypad can now be removed from the power switch board by gently pulling each of the rubber tabs through the PC board.

Removing the Speaker Assembly

1. Disconnect the speaker cable from the interface board.
2. Remove the speaker assembly and speaker foam.

CAUTION

When handling the speaker avoid touching the top of the speaker. Hold only the sides of the speaker when re-attaching the new foam.

Avoid covering the Mounting Plate screw.

Removing the A3 Display Assembly and the Touchscreen

1. Disconnect the following cables from the A1 front panel interface board: tape (item [14]) from connector and the LCD display to interface board cable (item [18]), LED driver board (backlight converter board) to interface board (item [11]), touch screen controller board to interface board cable (item [13]), power switch board to interface board cable (item [12]), and the speaker assembly cable.
2. Remove eleven outer screws (item ⑤) from the A3 display assembly's mounting plate and remove the A3 display assembly from the front panel assembly.
3. Raise the retaining clamps on the LCD display flat flex cable's two connectors (item [15]).
4. Disconnect the flat flex cable from the touchscreen (item [15]).
5. The LED driver board cable (item 22) can be removed from the connection on the LCD Display.
6. The LCD display cable (item [18]) can be removed by removing the three screws (item [17]) that attach it to the LCD display mounting bracket.
7. Remove the 3 screws on the slotted hole side of the mounting plate (item [20]).
8. Remove the 3 screws on the round hole side of the mounting plate (item [20]).
9. With a T-6 TORX (set to 3-in-lb), remove the 2 screws (item [23]) on the side bracket that has the LCD cable (item [18]) attached to the LCD display.

CAUTION

During re-assembly of the side brackets to the LCD display, it is very important to avoid over-tightening.

10. With a T-6 TORX (set to 3-in-lb), remove the 2 screws (item 23) on the 2nd side bracket (item [21]).

CAUTION

During re-assembly of the side brackets to the LCD display, it is very important to avoid over-tightening.

11. The touch screen can now be removed from the front panel assembly.
Note the orientation of the touch screen in the front panel assembly for installation of the new touch screen.

Figure 7-3 Front Panel Sub-assemblies Removal

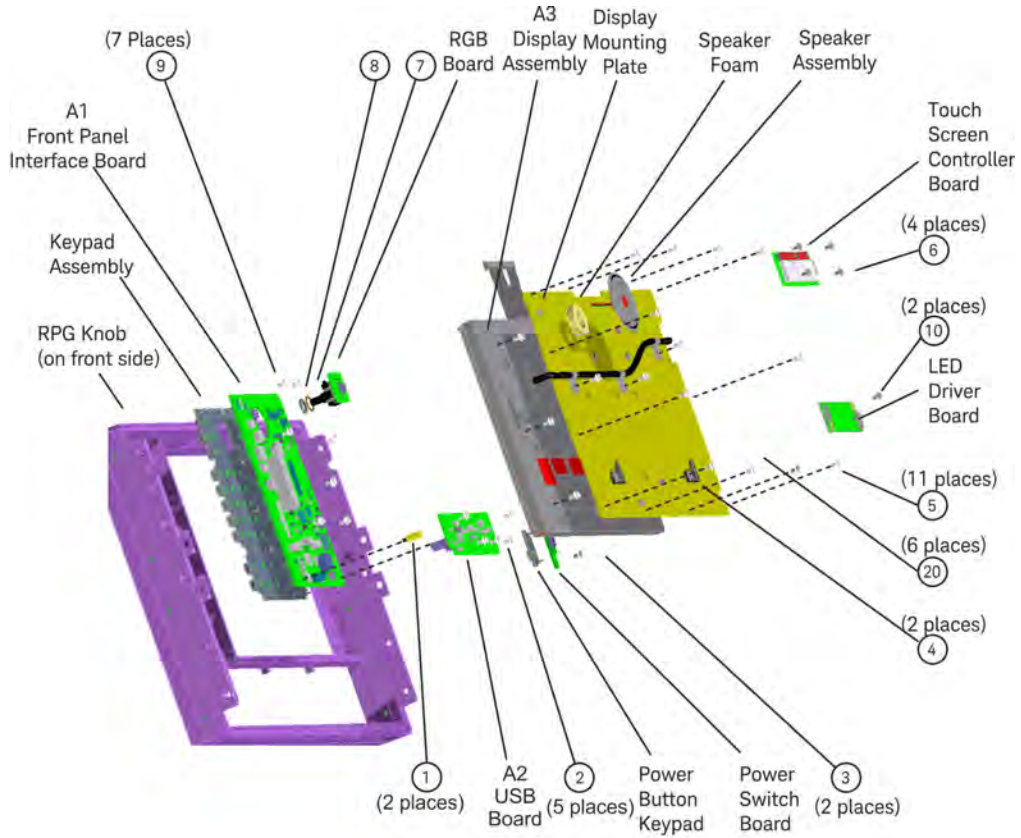

Figure 7-4 A3 Display Assembly with LCD Display - Cables

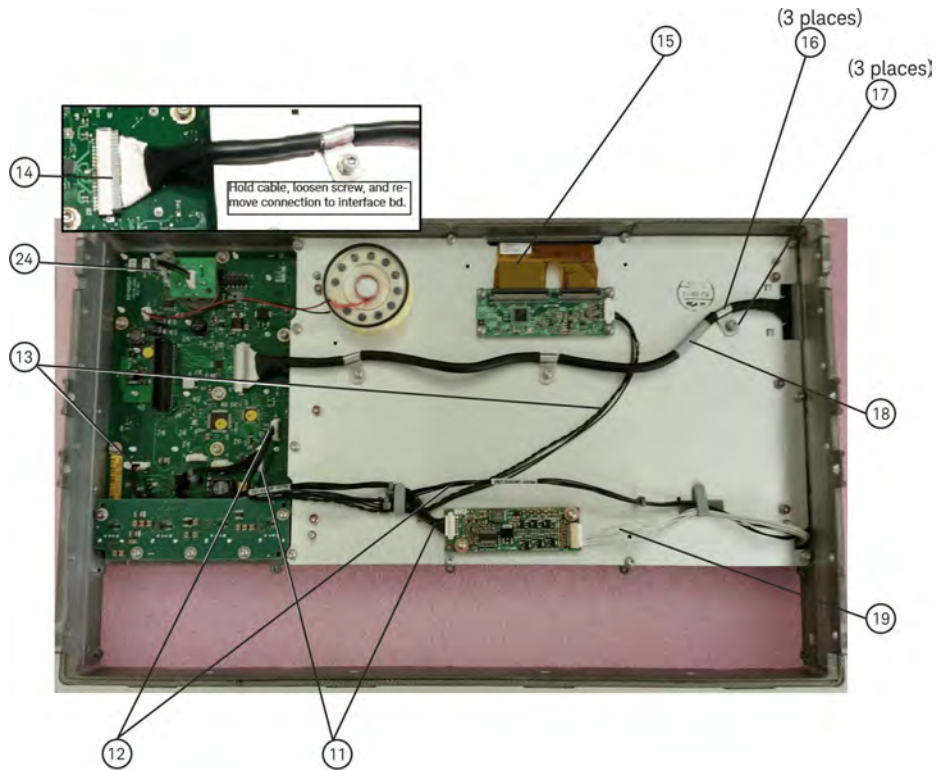

Figure 7-5 Remove LCD Cable, LCD to LED Inverter Board Cable, & Side Brackets

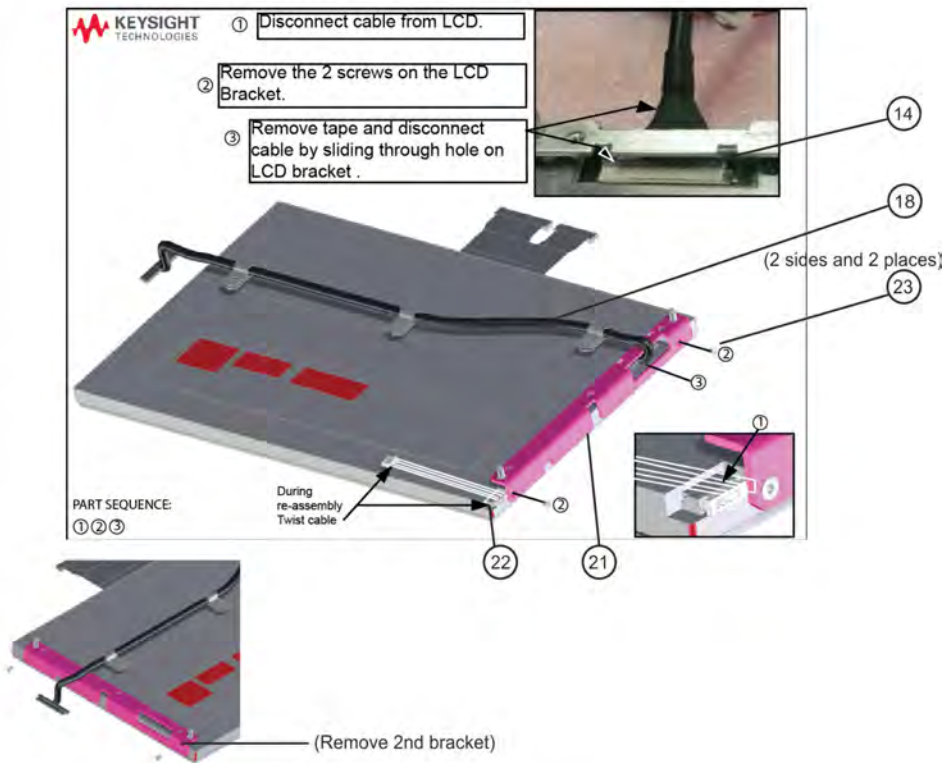

Figure 7-6

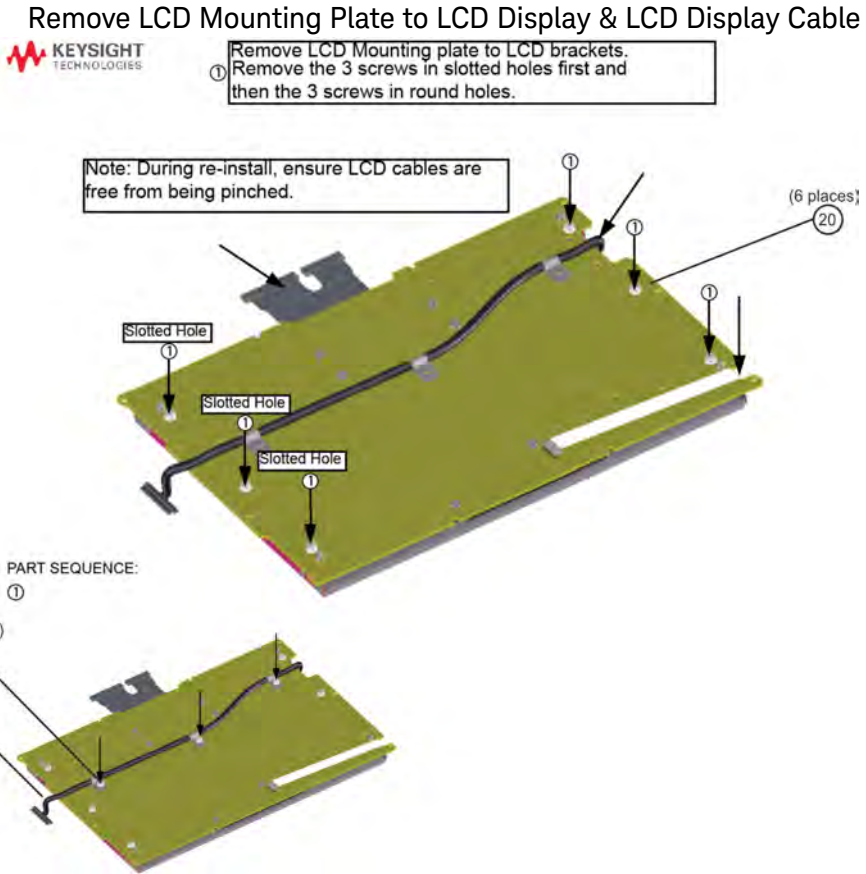

Figure 7-7 Removing the Flat Flex Cable from the LCD to the Controller Board

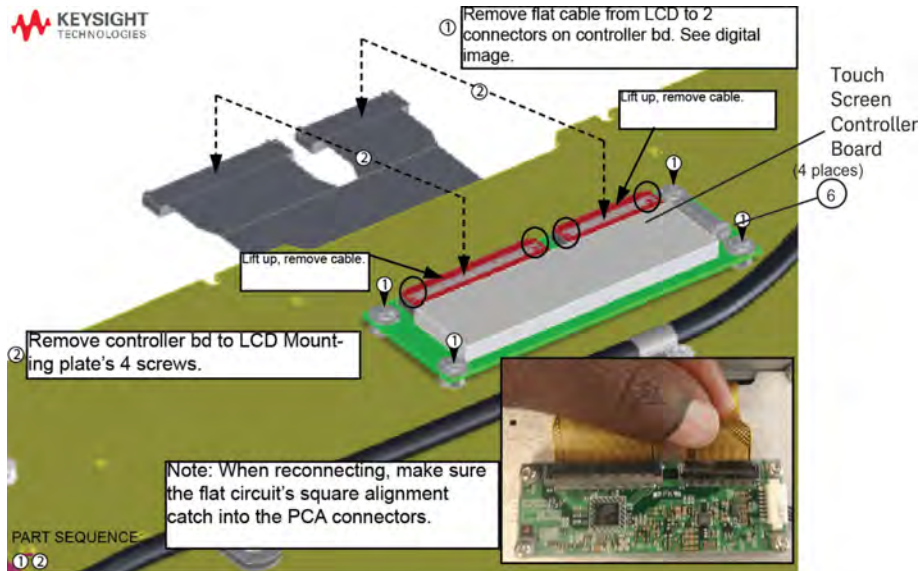

Figure 7-8

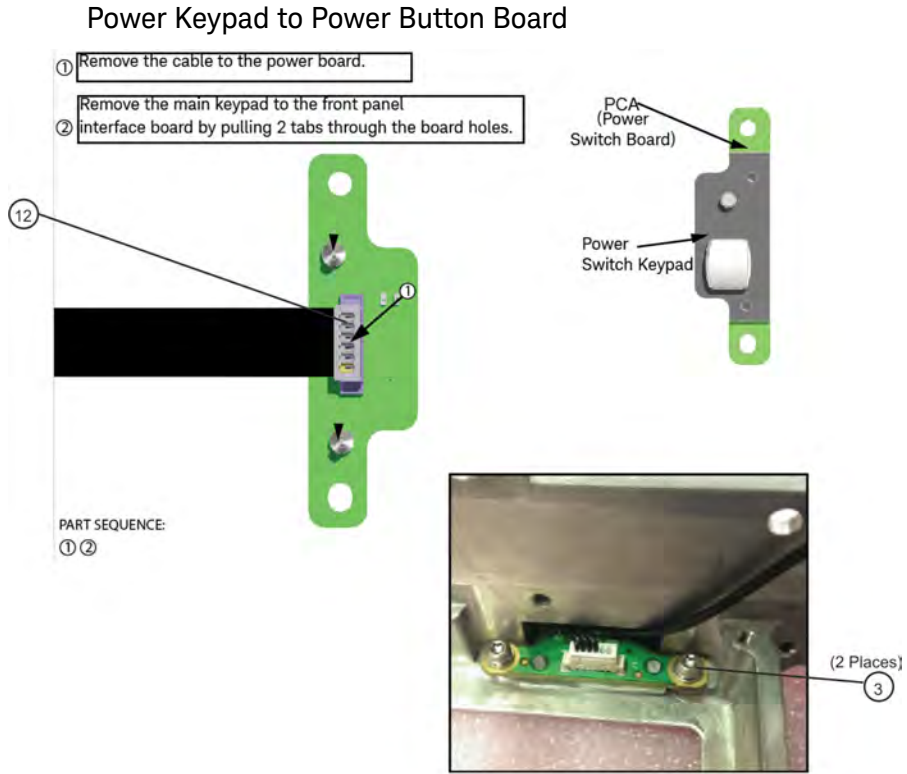
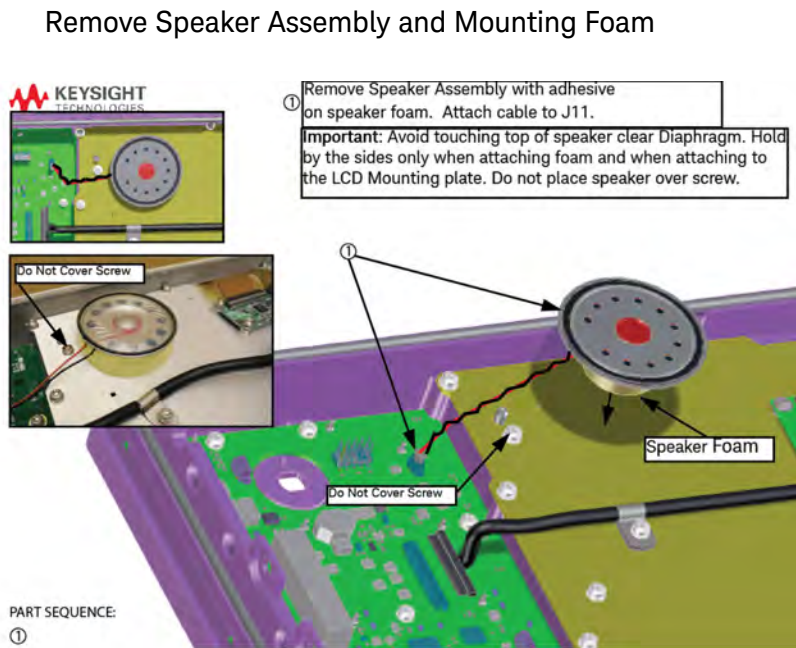

Figure 7-9



Replacement Procedure

1. Reverse the order of the removal procedure.
2. Perform the post-repair adjustments, verifications, and performance tests that pertain to this removal procedure. Refer to [Table 7-2 on page 7-47](#).

Removing and Replacing the A10, A11, and A12 Boards (For analyzers with serial numbers prefixed MY/SG/US5144 and below.)

NOTE

In February 2012, the N5264B analyzer underwent significant hardware changes. These changes included a redesigned Signal Processing ADC Module (SPAM) board, left side inner bracket, and right side inner bracket. It is very important that this redesigned hardware be used only with analyzer serial numbers prefixed MY/SG/US5204 and above. If you have an analyzer whose serial number is prefixed MY/SG/US5144 and below, you must use the previous version of hardware rather than the redesigned hardware - refer to **“Top Assemblies, All Options” on page 6-12.**

Be very careful to use the appropriate hardware in your analyzer. Using the wrong hardware can ruin analyzer components, resulting in additional customer costs.

Tools Required

- T-10 TORX driver (set to 9 in-lb)
- T-20 TORX driver (set to 21 in-lb)
- 5/16 inch open-end torque wrench (set to 10 in-lb)
- ESD grounding wrist strap

Removal Procedure

Refer to **Figure 7-10** for this procedure.

1. Disconnect the power cord.
2. Remove the outer and inner covers. Refer to **“Removing the Covers” on page 7-5.**
3. Remove all cables connected to the top of the board to be removed. Note the location of each cable for reinstallation.
4. Lift the two extractors (item ①), (one at each end of the board), and lift the board.
5. Before removing the board completely, check the bottom of the board for any attached cables and, if any, disconnect them.

Replacement Procedure

1. Reverse the order of the removal procedure.
2. Remember to connect any necessary cables to the bottom of the board before reinstalling it.
3. Perform the post-repair adjustments, verifications, and performance tests that pertain to this removal procedure. Refer to **Table 7-2 on page 7-47.**

Figure 7-10

A10, A11, and A12 Boards Removal

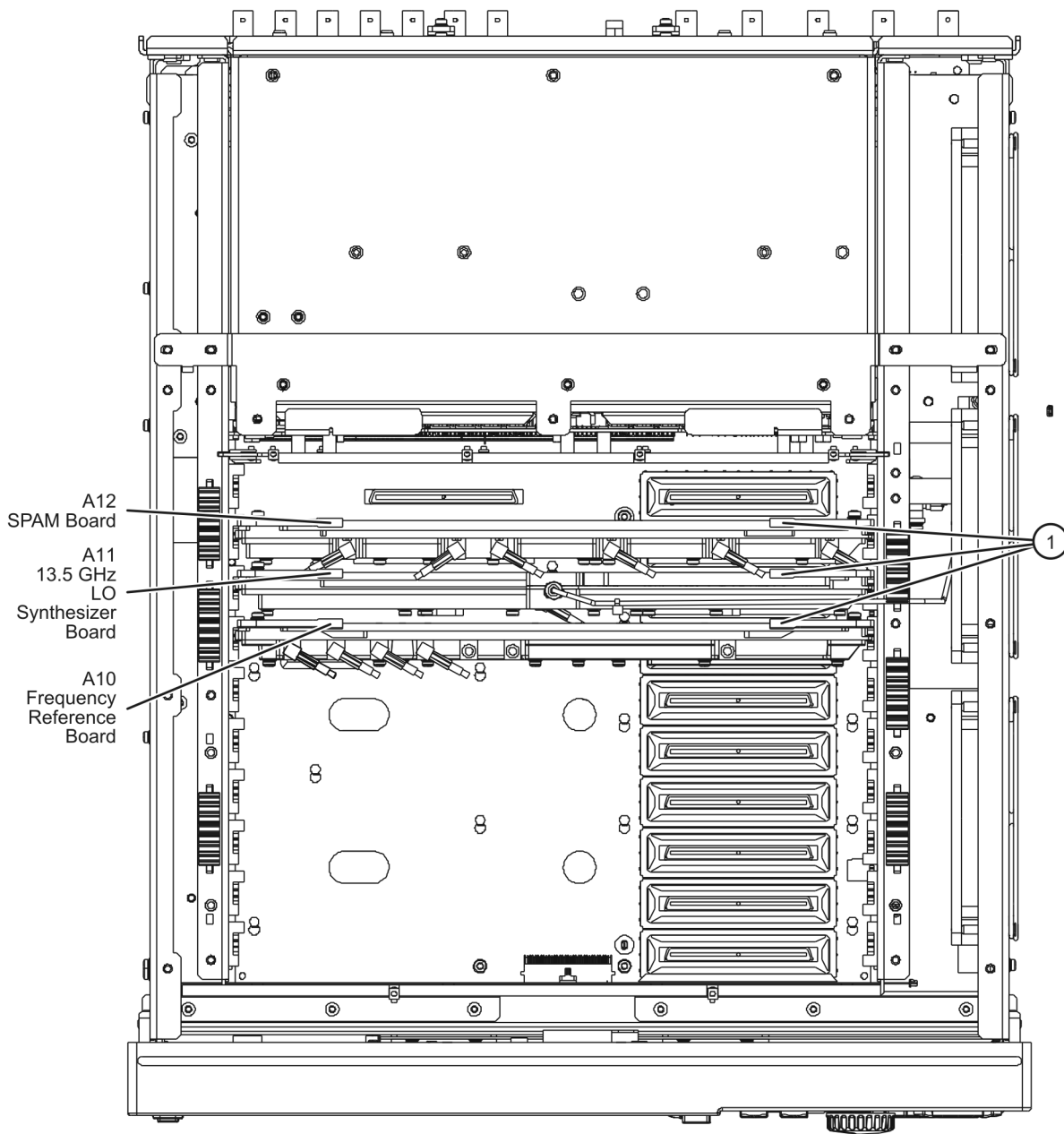

n5264_001_706

Removing and Replacing the A10, A11, and A12 Boards (For analyzers with serial numbers prefixed MY/SG/US5204 and above.)

NOTE

In February 2012, the N5264B analyzer underwent significant hardware changes. These changes included a redesigned Signal Processing ADC Module (SPAM) board, left side inner bracket, and right side inner bracket. It is very important that this redesigned hardware be used only with analyzer serial numbers prefixed MY/SG/US5204 and above. If you have an analyzer whose serial number is prefixed MY/SG/US5144 and below, you must use the previous version of hardware rather than the redesigned hardware - refer to **“Top Assemblies, All Options” on page 6-12.**

Be very careful to use the appropriate hardware in your analyzer. Using the wrong hardware can ruin analyzer components, resulting in additional customer costs.

Tools Required

- T-10 TORX driver (set to 9 in-lb)
- T-20 TORX driver (set to 21 in-lb)
- 5/16 inch open-end torque wrench (set to 10 in-lb)
- ESD grounding wrist strap

Removal Procedure

Refer to **Figure 7-10** for this procedure.

1. Disconnect the power cord.
2. Remove the outer and inner covers. Refer to **“Removing the Covers” on page 7-5.**
3. Remove all cables connected to the top of the board to be removed. Note the location of each cable for reinstallation.
4. On the top side of the analyzer, remove two screws (item ②), one at each end of the board, from the A12 SPAM board.
5. Lift the two extractors (item ①), (one at each end of the board), and lift the board.
6. Before removing the board completely, check the bottom of the board for any attached cables and, if any, disconnect them.

Replacement Procedure

1. Reverse the order of the removal procedure.
2. Remember to connect any necessary cables to the bottom of the board before reinstalling it.

3. Perform the post-repair adjustments, verifications, and performance tests that pertain to this removal procedure. Refer to [Table 7-2 on page 7-47](#).

Figure 7-11 A10, A11, and A12 Boards Removal

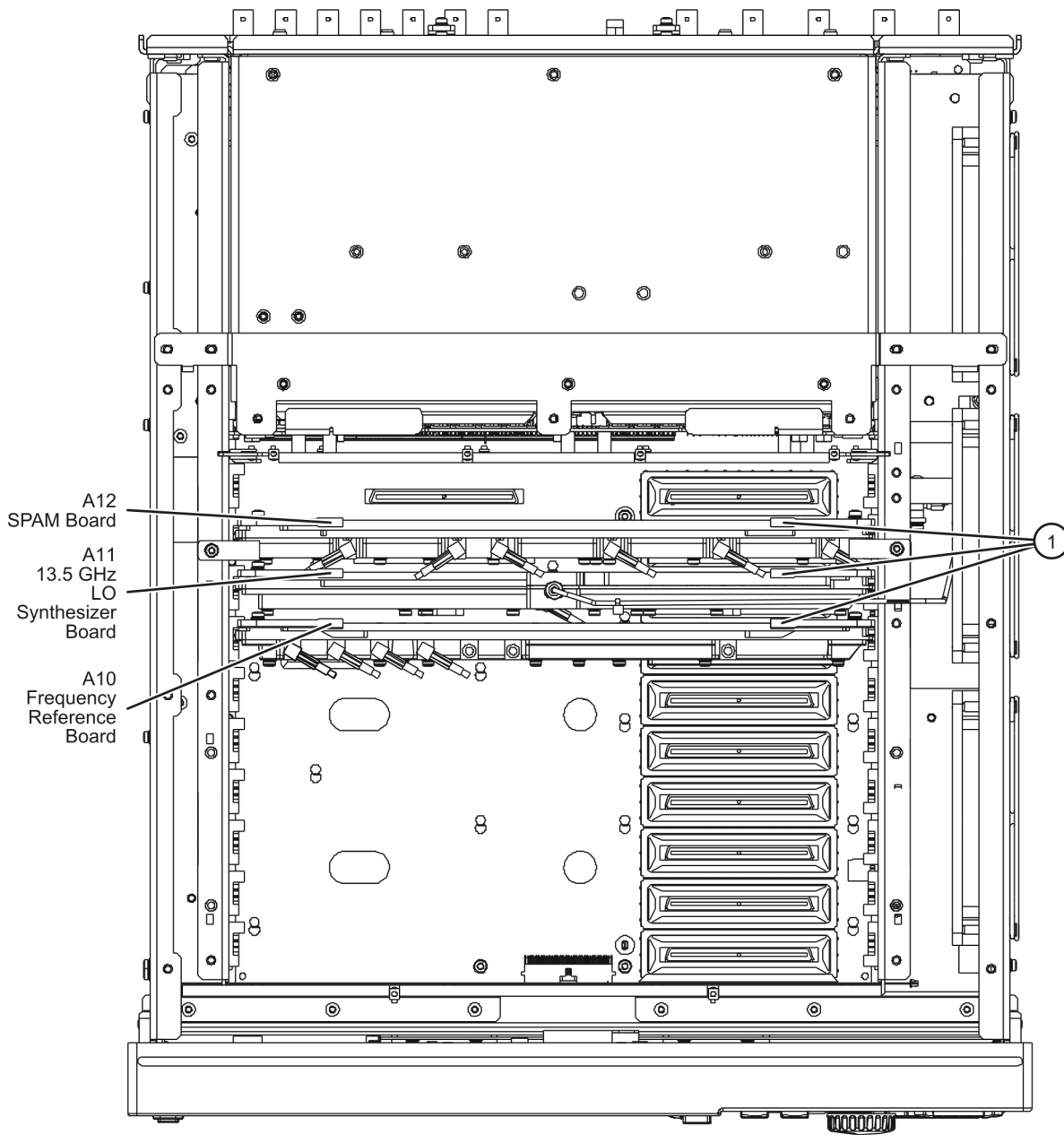

Some analyzers contain the N5245-60126 SPAM board (not shown). This board does not have tabs that attach to side rails with screws as shown above.

N5264_001_719

Removing and Replacing the A14 System Motherboard

Tools Required

- T-10 TORX driver (set to 9 in-lb)
- T-20 TORX driver (set to 21 in-lb)
- ESD grounding wrist strap

Removal Procedure

Refer to **Figure 7-12** for this procedure.

1. Disconnect the power cord.
2. Remove the outer and inner covers. Refer to **“Removing the Covers”** on page 7-5.
3. Remove the front panel assembly. Refer to **“Removing and Replacing the Front Panel Assembly”** on page 7-7.
4. Remove the A18 GPIB board. Refer to **“Removing and Replacing the A18 GPIB Board”** on page 7-30. (This results in the A16 power supply assembly and the A17 CPU board assembly also being removed.)
5. Remove the A15 midplane board. Refer to **“Removing and Replacing the A15 Midplane Board”** on page 7-24.
6. Remove the A10, A11, and A12 boards. Refer to **“Removing and Replacing the A10, A11, and A12 Boards (For analyzers with serial numbers prefixed MY/SG/US5144 and below.)”** on page 7-17.
7. Remove the fan bracket and fans. Refer to **“Removing and Replacing the Fans”** on page 7-43.
8. Turn the measurement receiver over so that the bottom side is up and remove four screws (item ①), that secure the bottom of the midplane bracket to the chassis.
9. Turn the measurement receiver back over so that the top side is up. Remove seven screws (item ②) that secure the left side bracket to the chassis left inner panel.
10. Remove two screws (item ③) from each side that secure the midplane bracket to the chassis left and right inner panels. Lift the midplane bracket out of the measurement receiver.
11. Remove three screws (item ④) that secure the A14 system motherboard to the chassis.
12. Slide the A14 system motherboard toward the rear of the measurement receiver to release it from the 15 keyhole standoffs (item ⑤) on the chassis.

- 13.** Lift the A14 system motherboard just enough to unplug the ribbon cable from the bottom side, then lift it out of the measurement receiver.

Replacement Procedure

1. Reverse the order of the removal procedure.
2. Perform the post-repair adjustments, verifications, and performance tests that pertain to this removal procedure. Refer to [Table 7-2 on page 7-47](#).

Figure 7-12 A14 System Motherboard Removal

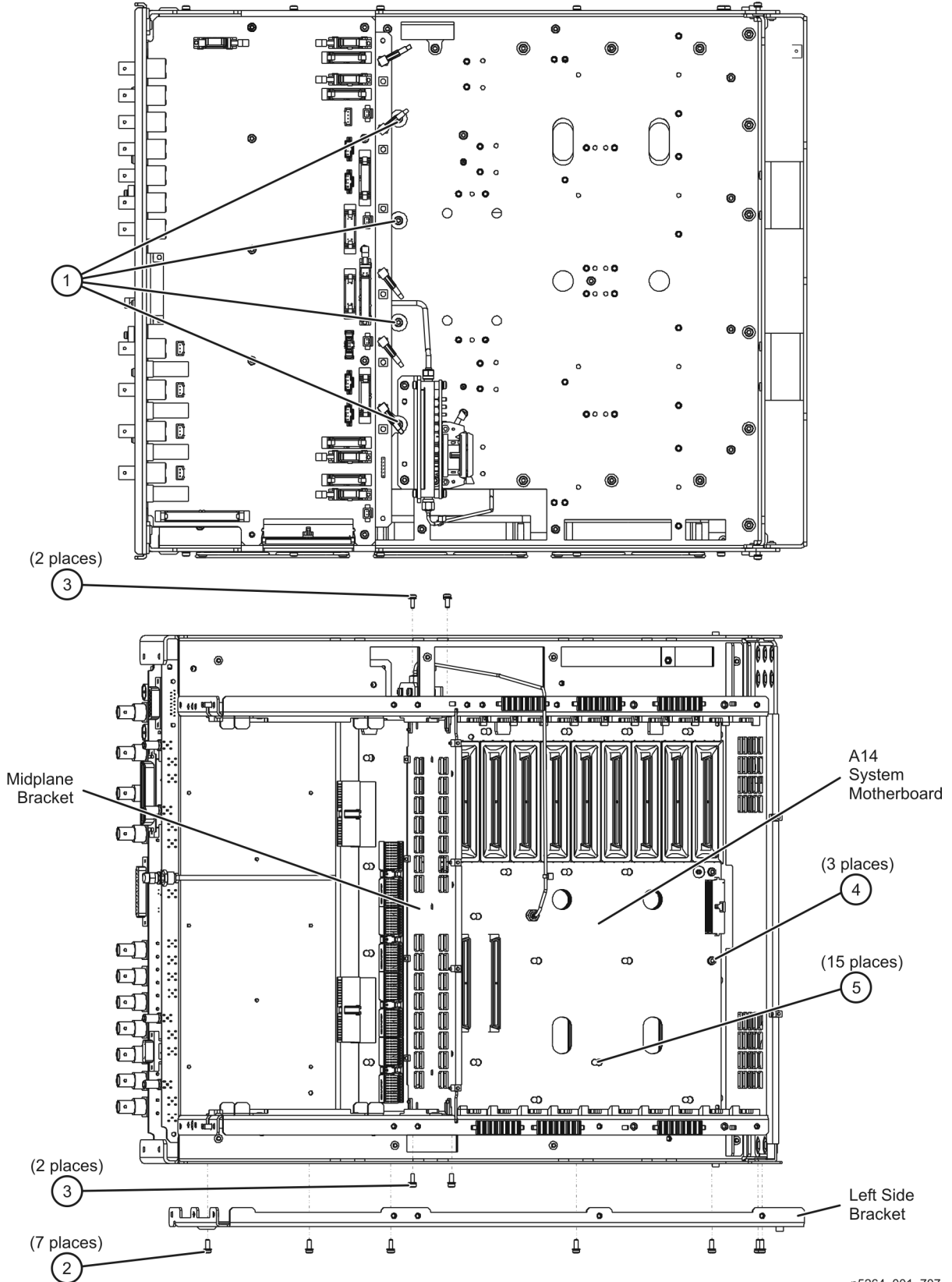

n5264_001_707

Removing and Replacing the A15 Midplane Board

Tools Required

- T-10 TORX driver (set to 9 in-lb)
- T-20 TORX driver (set to 21 in-lb)
- ESD grounding wrist strap

Removal Procedure

Refer to **Figure 7-13** for this procedure.

1. Disconnect the power cord.
2. Remove the outer and inner covers. Refer to **“Removing the Covers”** on **page 7-5**.
3. Remove the A16 power supply assembly. Refer to **“Removing and Replacing the A16 Power Supply Assembly”** on **page 7-26**.
4. Remove the A17 CPU board assembly. Refer to **“Removing and Replacing the A17 CPU Board Assembly”** on **page 7-28**.
5. Remove six screws (item ①) from the A15 midplane board.
6. Lift the board ejectors (item ②) to the upright position to disengage the A15 midplane board from the A14 system motherboard.
7. Note the positions of the five rubber grommets (item ③) on the bottom three A15 midplane board alignment pins. Remove these rubber grommets and retain them for reinstallation on the new A15 midplane board.
8. Lift the A15 midplane board out of the measurement receiver.

Replacement Procedure

1. Reverse the order of the removal procedure.

Be careful to align the guide pins on the A15 midplane board connectors with the slots on the A14 system motherboard connectors.

The board ejectors should be in the upright position when installing the A15 midplane board. Align these ejectors with the slots in the chassis inner panels as the board is lowered into position and then push them down flat.

Remember to install the five rubber grommets on the bottom three alignment pins: one on the alignment pin closest to the fans and two each on the other two alignment pins.

2. Perform the post-repair adjustments, verifications, and performance tests that pertain to this removal procedure. Refer to **Table 7-2** on **page 7-47**.

Figure 7-13 A15 Midplane Board Removal

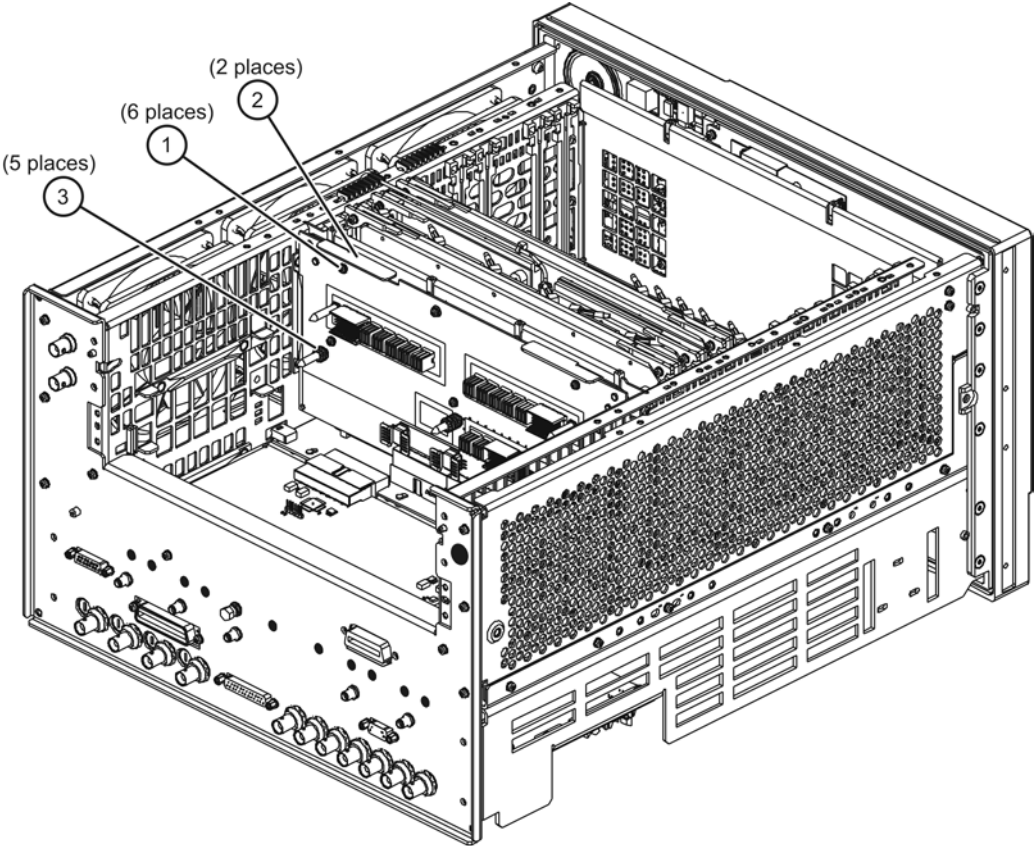

n5264_001_708

Removing and Replacing the A16 Power Supply Assembly

Tools Required

- T-10 TORX driver (set to 9 in-lb)
- T-20 TORX driver (set to 21 in-lb)
- ESD grounding wrist strap

Removal Procedure

Refer to **Figure 7-14** for this procedure.

1. Disconnect the power cord.
2. Remove the outer and inner covers. Refer to **“Removing the Covers”** on **page 7-5**.
3. Remove the three flat head screws (item ①) from the power supply bracket.
4. Remove the seven pan head screws (item ②) from the power supply rear panel.
5. Slide the A16 power supply assembly out the rear of the measurement receiver.

Replacement Procedure

1. Reverse the order of the removal procedure.
2. Perform the post-repair adjustments, verifications, and performance tests that pertain to this removal procedure. Refer to **Table 7-2** on **page 7-47**.

Figure 7-14 A16 Power Supply Assembly Removal

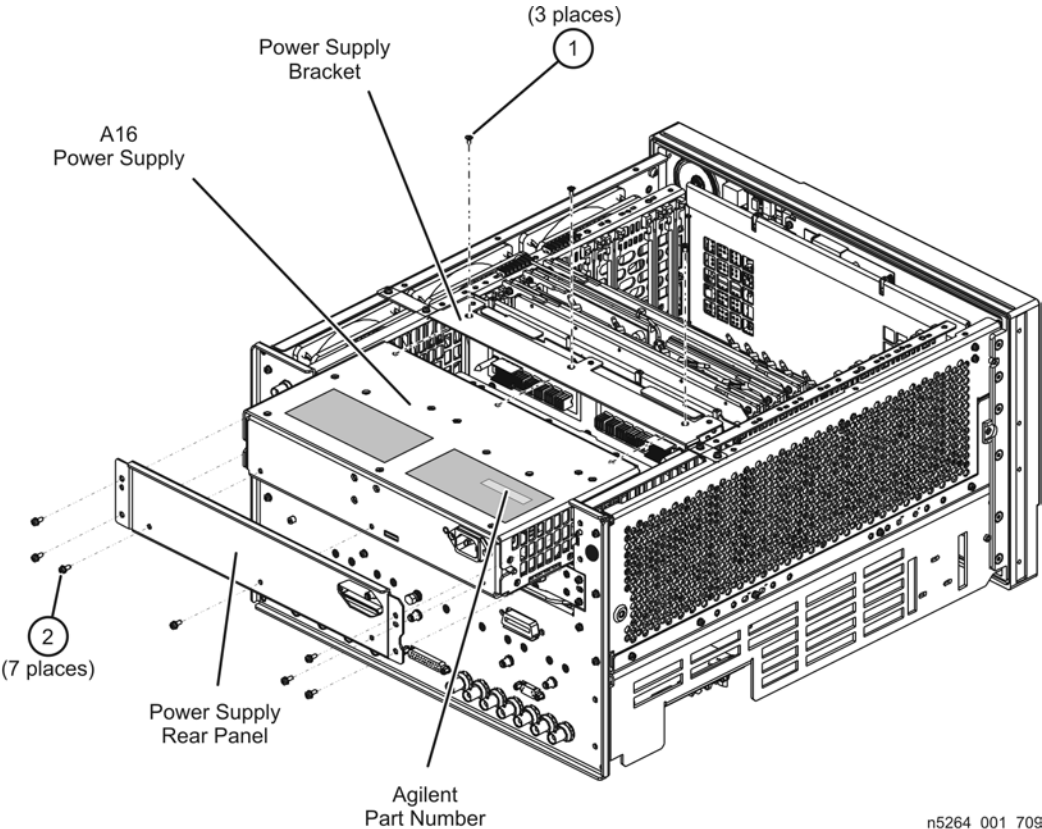

n5264_001_709

Removing and Replacing the A17 CPU Board Assembly

Tools Required

- T-10 TORX driver (set to 9 in-lb)
- T-20 TORX driver (set to 21 in-lb)
- ESD grounding wrist strap

Removal Procedure

Refer to **Figure 7-15** for this procedure.

1. Disconnect the power cord.
2. It is **not** necessary to remove the instrument cover(s) to remove the A17 CPU board assembly.
3. Remove six screws (item ①) from the A17 CPU board assembly; four from the CPU assembly rear panel and two from the ejector handles.
4. Grasp the two ejector handles and rotate them outward toward the sides of the measurement receiver as shown in the illustration. This will disengage the A17 CPU board assembly from the A15 midplane board.
5. Slide the A17 CPU board assembly out the rear of the measurement receiver.
6. If the A17 CPU board assembly is being replaced, you must first remove the A51 hard disk drive for reinstallation in the new A17 CPU board assembly. Refer to **“Removing and Replacing the A51 Solid State Drive (SSD)”** on page 7-39.

Replacement Procedure

1. Reverse the order of the removal procedure.
2. Perform the post-repair adjustments, verifications, and performance tests that pertain to this removal procedure. Refer to **Table 7-2** on page 7-47.

Figure 7-15 A17 CPU Board Assembly Removal

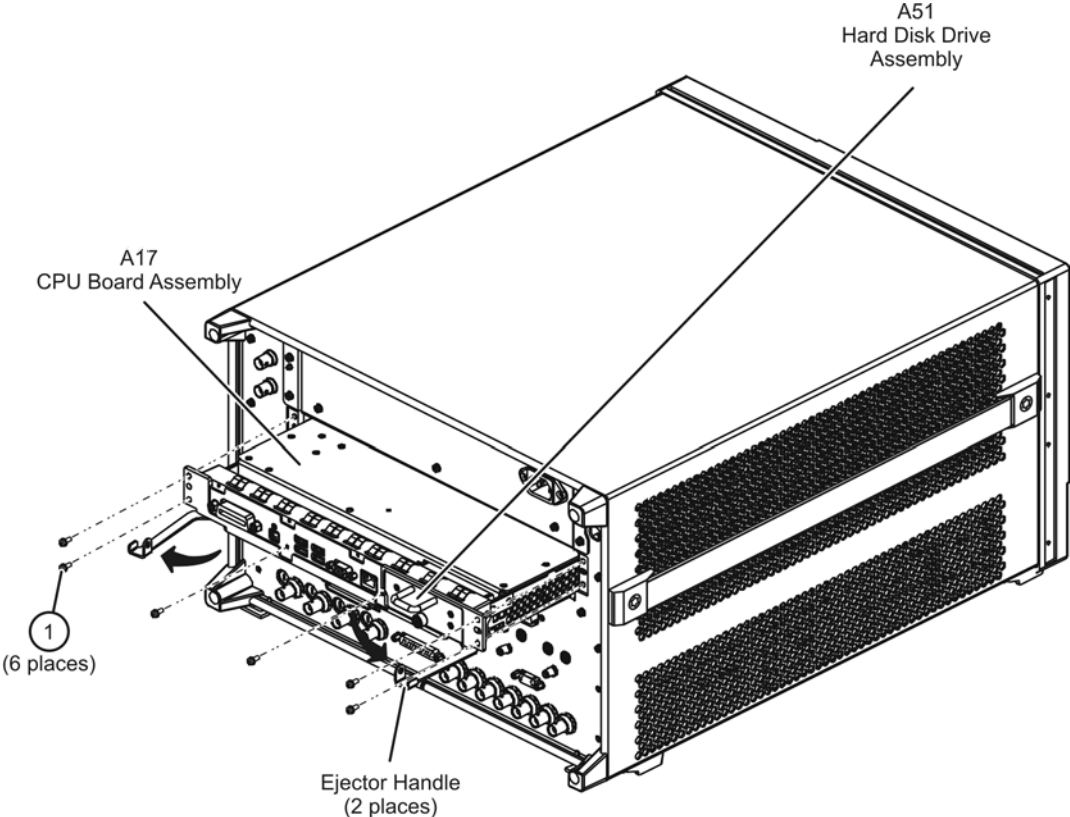

n5264_001_710

Removing and Replacing the A18 GPIB Board

Tools Required

- T-10 TORX driver (set to 9 in-lb)
- T-20 TORX driver (set to 21 in-lb)
- ESD grounding wrist strap

Removal Procedure

Refer to **Figure 7-16** for this procedure.

1. Disconnect the power cord.
2. Remove the A16 power supply assembly. Refer to **“Removing and Replacing the A16 Power Supply Assembly”** on page 7-26.
3. Remove the A17 CPU board assembly. Refer to **“Removing and Replacing the A17 CPU Board Assembly”** on page 7-28.
4. Remove the rear panel. Refer to **“Removing and Replacing the Rear Panel”** on page 7-41.
5. Slide the A18 GPIB board out the rear of the measurement receiver.

Replacement Procedure

1. Reverse the order of the removal procedure.
2. Perform the post-repair adjustments, verifications, and performance tests that pertain to this removal procedure. Refer to **Table 7-2** on page 7-47.

Figure 7-16 A18 GPIB Board Removal

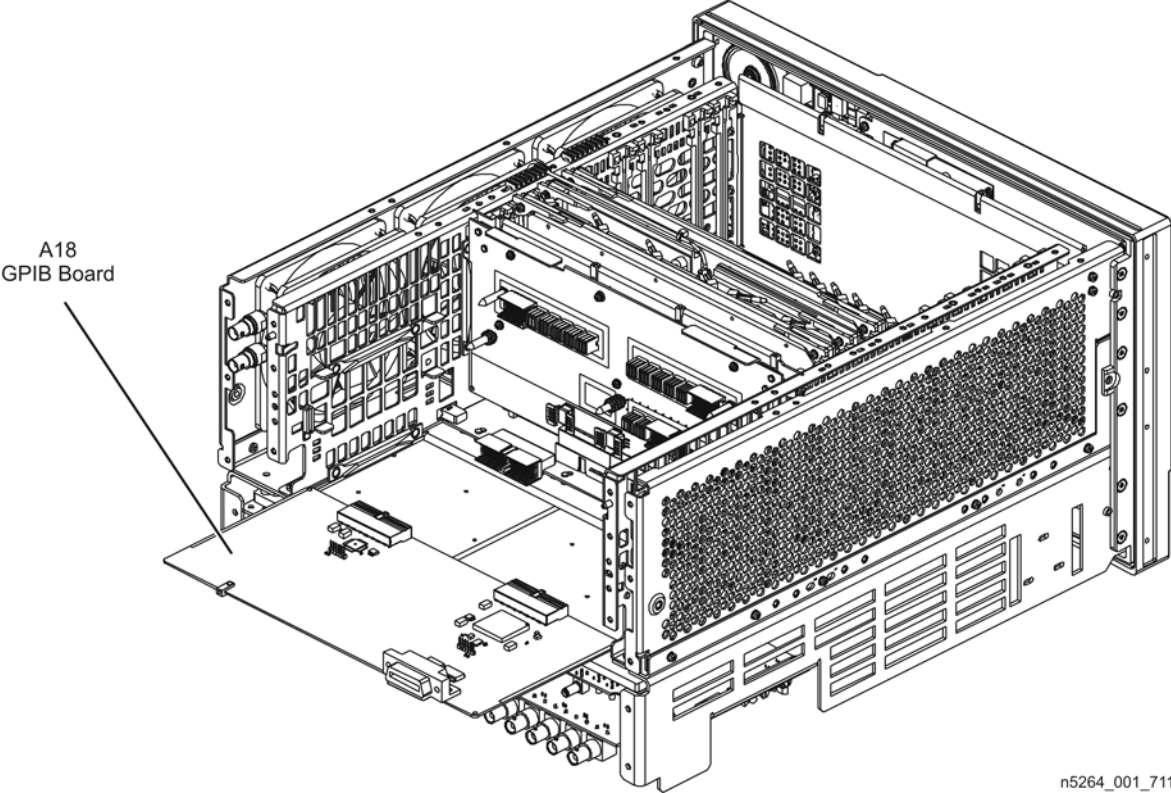

n5264_001_711

Removing and Replacing the A19 Test Set Motherboard

CAUTION

Before replacing the A19 board, if possible:

Run EEBackup.exe using the directory for your Windows operating system:

Windows 7 OS:

C:/Program Files (x86)/Agilent/Network Analyzer/Service/EEBackup.exe.
Click on Save EEPROM Backup, and then click on Backup TSMB Memory.

Windows 10 OS (32-bit):

C:/Program Files (x86)/Keysight/Network Analyzer/Service/EEBackup.exe.
Click on Save EEPROM Backup, and then click on Backup TSMB Memory.

The firmware revision numbers for Win10 (32-bit) are A.13.30.xx through A.13.95.xx.

Windows 10 OS (64-bit):

C:/Program Files/Keysight/Network Analyzer/Service/EEBackup.exe. Click on Save EEPROM Backup, and then click on Backup TSMB Memory.

The firmware revision numbers for Win10 (64-bit) are A.14.00.xx and up.

If it is not possible to back up the EEPROMs and the TSMB Memory, the data files might not be the most current. In this case, the backup data will contain the original factory information. If you have problems, “[Contacting Keysight](#)” on page 2-8.

Tools Required

- T-10 TORX driver (set to 9 in-lb)
- T-20 TORX driver (set to 21 in-lb)
- ESD grounding wrist strap

Removal Procedure

Refer to [Figure 7-17](#) for this procedure.

1. Disconnect the power cord.
2. Remove the outer cover. Refer to “[Removing the Covers](#)” on page 7-5.
3. Position the measurement receiver bottom side up.
4. Disconnect ALL ribbon cables (item ①) and ALL wire harnesses (item ②) from the A19 test set motherboard.
5. Remove connector hardware (item ③) from 11 rear panel BNC connectors.
6. Remove connector hardware (item ④) from the rear panel TEST SET I/O connector.
7. Remove 10 screws (item ⑤) from the A19 test set motherboard.

8. Slide the A19 test set motherboard toward the front of the instrument until the rear panel BNC connectors are free of the rear panel, then lift the motherboard and remove it from the measurement receiver.

Replacement Procedure

1. Reverse the order of the removal procedure.
2. Perform the post-repair adjustments, verifications, and performance tests that pertain to this removal procedure. Refer to [Table 7-2 on page 7-47](#).

Figure 7-17 A19 Test Set Motherboard Removal

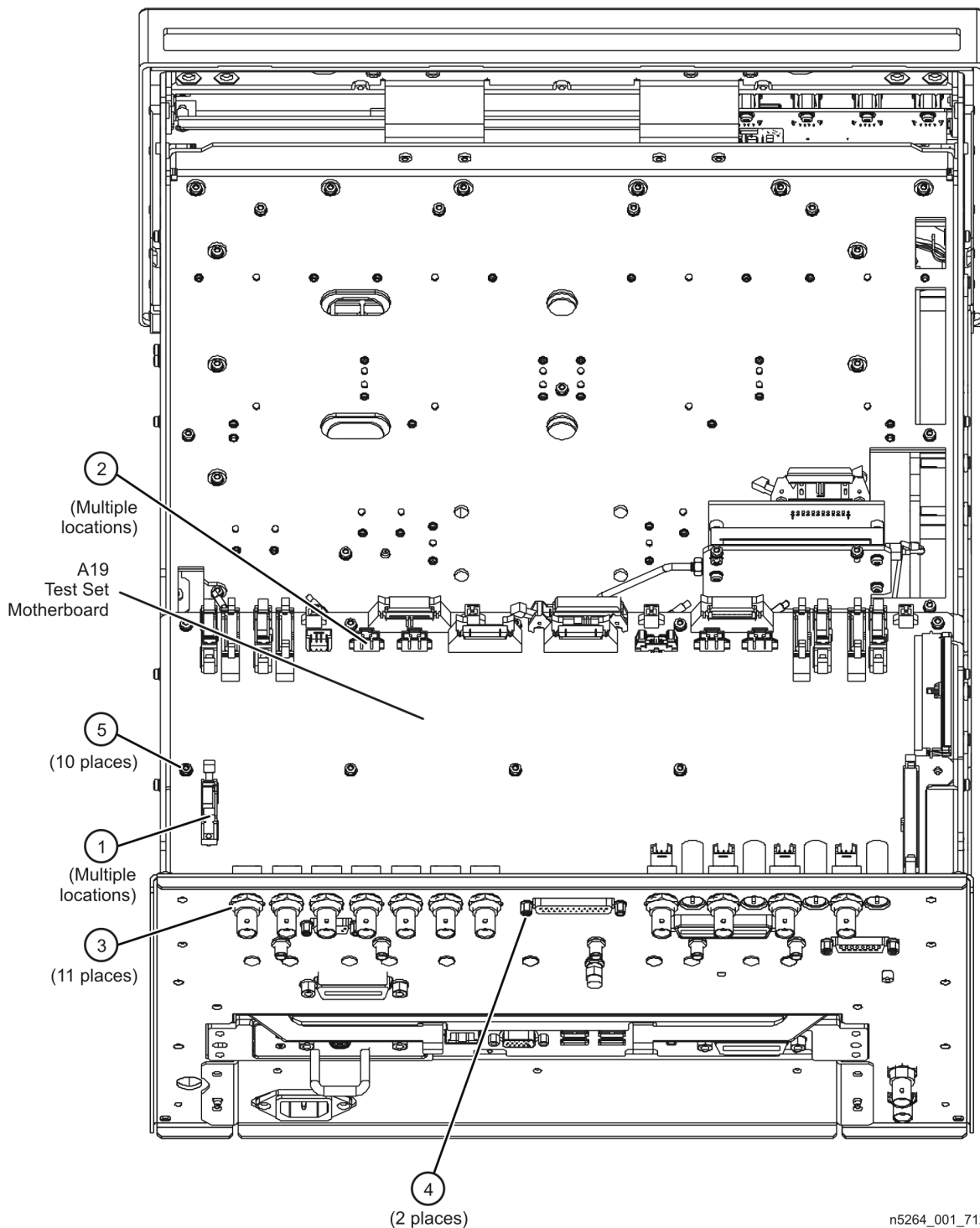

n5264_001_712

Removing and Replacing the A20 IF Multiplexer Board

Tools Required

- T-10 TORX driver (set to 9 in-lb)
- T-20 TORX driver (set to 21 in-lb)
- ESD grounding wrist strap

Removal Procedure

Refer to **Figure 7-18** for this procedure.

1. Disconnect the power cord.
2. Remove the outer cover. Refer to **“Removing the Covers”** on page 7-5.
3. Position the measurement receiver bottom side up.
4. Remove the A19 test set motherboard. Refer to **“Removing and Replacing the A19 Test Set Motherboard”** on page 7-32.
5. Disconnect the ribbon cable (item ①) from the A20 IF multiplexer board.
6. Disconnect ALL gray flexible RF cables (item ②) from the A20 IF multiplexer board.
7. Remove connector hardware (item ③) from five rear panel RF connectors.
8. Remove connector hardware (item ④) from the rear panel PULSE I/O connector.
9. Remove four screws (item ⑤) from the stabilizer bracket and remove the stabilizer bracket.
10. Remove four screws (item ⑥) from the A20 IF multiplexer board.
11. Slide the A20 IF multiplexer board toward the front of the instrument until the rear panel connectors are free of the rear panel, then lift the motherboard and remove it from the measurement receiver.

Replacement Procedure

1. Reverse the order of the removal procedure.

Attach the stabilizer bracket to the new A20 IF multiplexer board using the screws removed from the old one.

Torque rear panel RF connector nuts to 21 in-lbs and PULSE I/O connector screws to 6 in-lbs.

2. Perform the post-repair adjustments, verifications, and performance tests that pertain to this removal procedure. Refer to **Table 7-2** on page 7-47.

Figure 7-18 A20 IF Multiplexer Board Removal

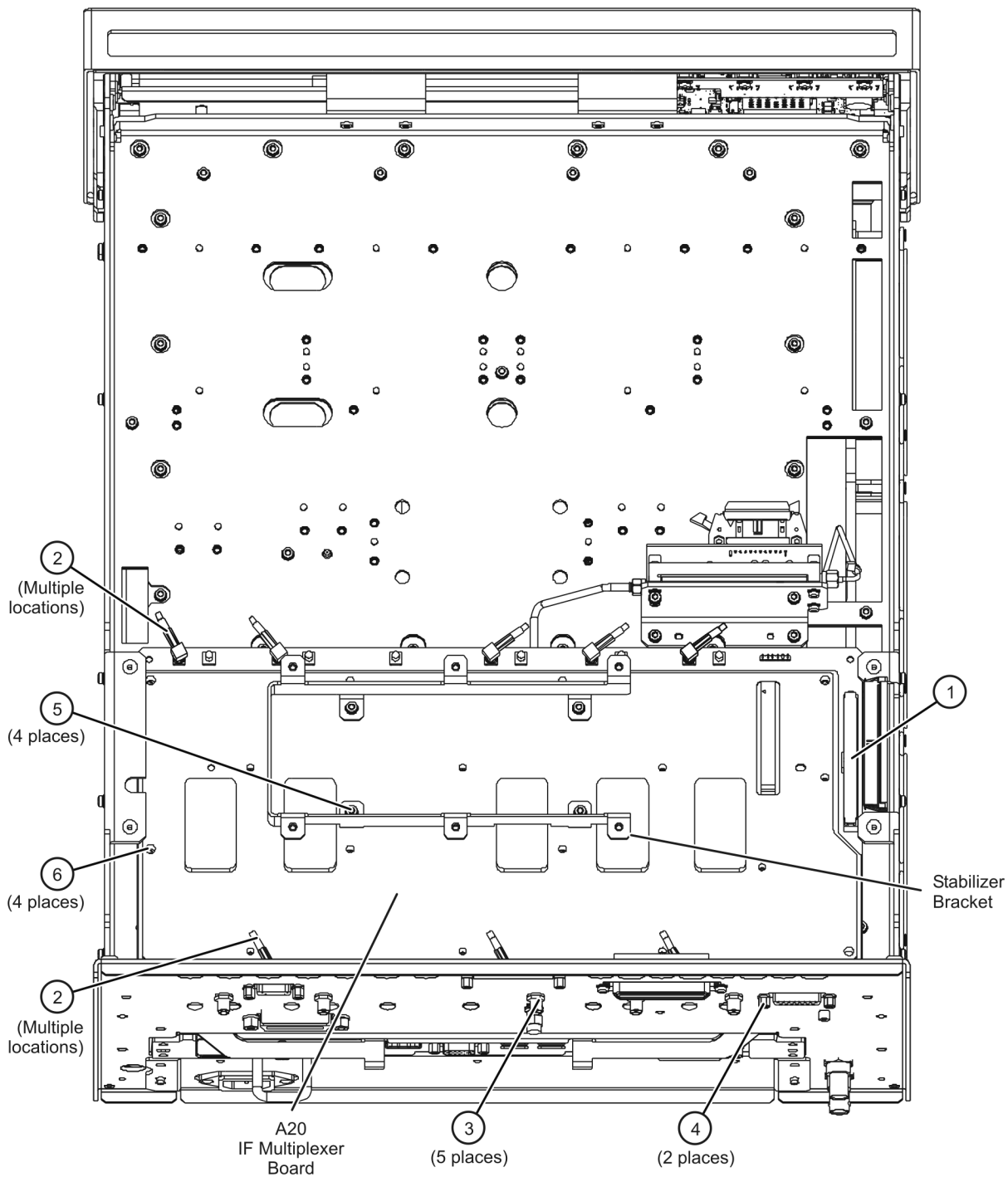

n5264_001_713

Removing and Replacing the A21 HMA26.5

Tools Required

- T-10 TORX driver (set to 9 in-lb)
- T-20 TORX driver (set to 21 in-lb)
- 5/16 inch open-end torque wrench (set to 10 in-lb)
- ESD grounding wrist strap

Removal Procedure

Refer to [Figure 7-19](#) for this procedure.

CAUTION

Be careful not to damage the center pins of the semirigid cables. Some flexing of the cables is necessary to remove the assembly. However, do not over-bend the semirigid cables.

1. Disconnect the power cord.
2. Remove the outer cover. Refer to [“Removing the Covers” on page 7-5](#).
3. Position the measurement receiver bottom side up.
4. Disconnect the ribbon cable (item ①) from the A21 HMA26.5 assembly.
5. Disconnect cable W41 from the A21 HMA26.5.
6. Disconnect cable W47 at the A21 HMA26.5.
7. Remove two screws (item ②) from the A21 HMA26.5 mounting bracket.
8. Remove the mounting bracket, with the A21 HMA26.5 attached, from the measurement receiver.
9. Remove four screws (item ③) that attach the A21 HMA26.5 to the mounting bracket.

Replacement Procedure

1. Reverse the order of the removal procedure.
Torque all RF cable connectors to 10 in-lbs.
2. Perform the post-repair adjustments, verifications, and performance tests that pertain to this removal procedure. Refer to [Table 7-2 on page 7-47](#).

Figure 7-19 A21 HMA26.5 Removal

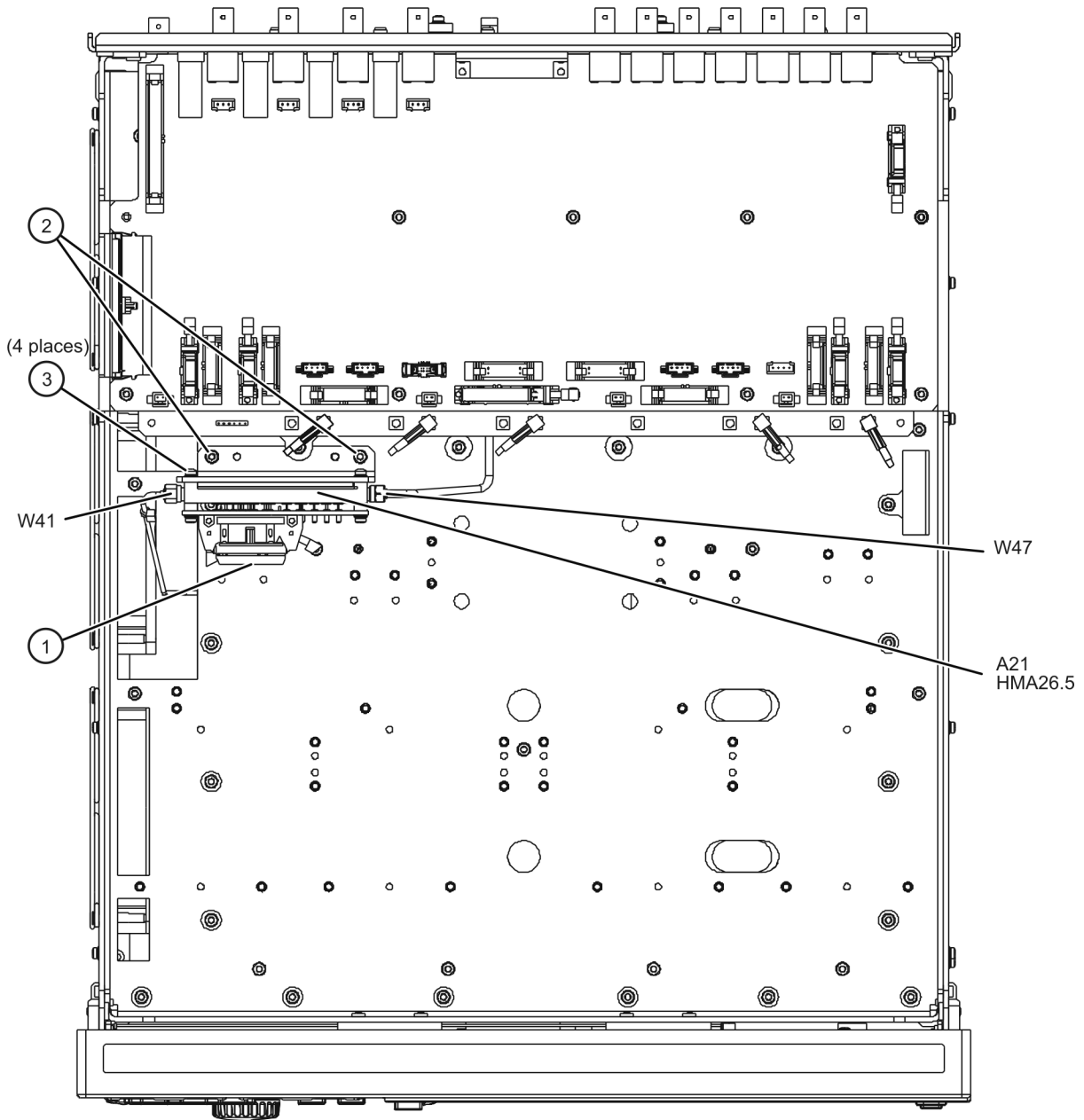

n5264_001_714

Removing and Replacing the A51 Solid State Drive (SSD)

Certain unique files exist on the SSD that are necessary for proper operation of your analyzer. These files must be copied to another location to allow them to be installed onto the new SSD after it has been installed.

If you are replacing the SSD, the following procedure must be performed first.

Copy Unique Files from the Hard Disk

- If installing an SSD for Windows XP: if the user has loaded unique calibration kit information, navigate to `C:\Program Files\Keysight\Network Analyzer` and copy USER_CALKITFILE to a USB flash memory drive. Also copy any personal user files that you wish to preserve.

Obsolete. Reference only.

- If installing an SSD for Windows 7: for more information on the N8984A SSD, refer to the *Windows 7 Operating System Upgrade Kit Installation Note*, available online at <https://www.keysight.com/us/en/assets/9018-04311/installation-guides/9018-04311.pdf> (N8984-90001).

Obsolete. Reference only.

- If installing an SSD for Windows 10: for more information on the N8985A SSD, refer to the *Windows 10 Operating System Upgrade Kit Installation Note*, available online at <https://www.keysight.com/us/en/assets/9018-04733/installation-guides/9018-04733.pdf> (N8985-90001).

Tools Required

- T-10 TORX driver (set to 9 in-lb; for hard disk drive replacement)
- ESD grounding wrist strap

Removal Procedure

Refer to **Figure 7-20** for this procedure.

1. Disconnect the analyzer power cord.
2. Position the analyzer for access to the rear panel.
3. Loosen the SSD assembly thumb screw (item ①).
4. Pull the SSD assembly out from the CPU assembly, using the handle (item ②).

Figure 7-20 SSD Assembly Removal

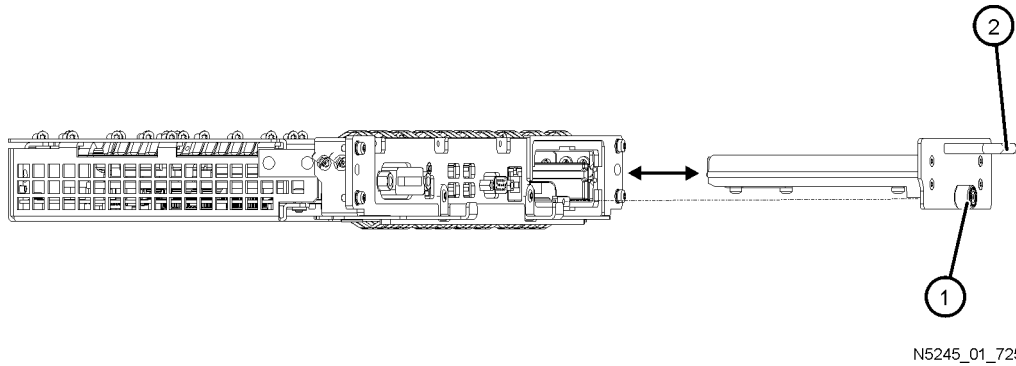

Reinstalling the SSD

1. Reverse the order of the removal procedure.

Install Backup Files onto the New SSD

The files that were previously saved onto a USB flash memory drive must now be installed onto the new SSD. The network analyzer must be powered up and operating.

Removing and Replacing the Rear Panel

Tools Required

- T-10 TORX driver (set to 9 in-lb)
- T-20 TORX driver (set to 21 in-lb)
- ESD grounding wrist strap

Removal Procedure

Refer to **Figure 7-21** for this procedure.

1. Disconnect the power cord.
2. Remove the outer and inner covers. Refer to **“Removing the Covers”** on **page 7-5**.
3. Remove the A16 power supply assembly. Refer to **“Removing and Replacing the A16 Power Supply Assembly”** on **page 7-26**.
4. Remove the A17 CPU board assembly. Refer to **“Removing and Replacing the A17 CPU Board Assembly”** on **page 7-28**.
5. Remove the termination (item ①).
6. Remove the connector hardware (item ②) from each of the five multi-pin connectors. The hardware is not the same on each connector so note which hardware goes with which connector.
7. Remove the connector hardware (item ③) from each of the RF connectors. The hardware is not the same on each connector so note which hardware goes with which connector.
8. Remove the 13 screws (item ④) that attach the rear panel to the chassis.
9. Slide the rear panel over the cable connectors and off of the measurement receiver.

Replacement Procedure

1. Reverse the order of the removal procedure.
2. Perform the post-repair adjustments, verifications, and performance tests that pertain to this removal procedure. Refer to **Table 7-2** on **page 7-47**.

Figure 7-21 Rear Panel Removal

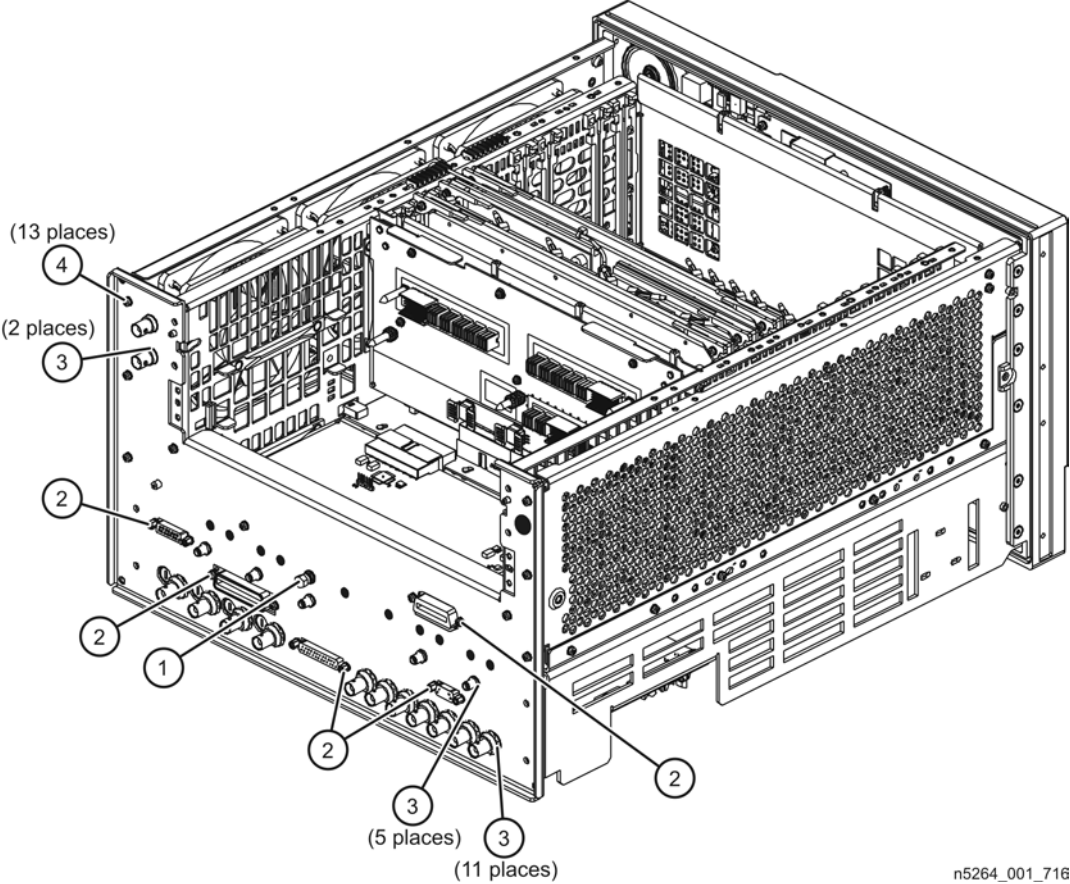

n5264_001_716

Removing and Replacing the Fans

Tools Required

- T-10 TORX driver (set to 9 in-lb)
- T-20 TORX driver (set to 21 in-lb)
- Pozidriv screw driver
- ESD grounding wrist strap

Removal Procedure

Refer to **Figure 7-22** for this procedure.

1. Disconnect the power cord.
2. Remove the outer and inner covers. Refer to **“Removing the Covers”** on **page 7-5**.
3. Remove the front panel assembly. Refer to **“Removing and Replacing the Front Panel Assembly”** on **page 7-7**.
4. Remove the power supply bracket. It is not necessary to remove the entire power supply, just the power supply bracket. Refer to **“Removing and Replacing the A16 Power Supply Assembly”** on **page 7-26**.
5. Remove five screws (item ①) that attach the fan bracket to the chassis.
6. Remove three screws (item ②) that attach the rear panel to the fan bracket.
7. Raise the fan bracket out of the measurement receiver just enough to access the fan cables. Disconnect the fan cables from the A14 system motherboard connectors (item ③).
8. Remove the fan bracket and fans from the measurement receiver.
9. To remove a fan or fan guard from the fan bracket:
 - a. Before removing a fan or fan guard, note the orientation of each fan and fan guard for reinstallation.
 - b. Pull up the center pin of each of the fan rivets as shown by (item ④) in the illustration.
 - c. Pull out the rivet completely (as shown by (item ⑤) in the illustration) to release the fan and fan guard.

Replacement Procedure

1. Reverse the order of the removal procedure.
2. Perform the post-repair adjustments, verifications, and performance tests that pertain to this removal procedure. Refer to **Table 7-2** on **page 7-47**.

Figure 7-22 B1 Fan Removal

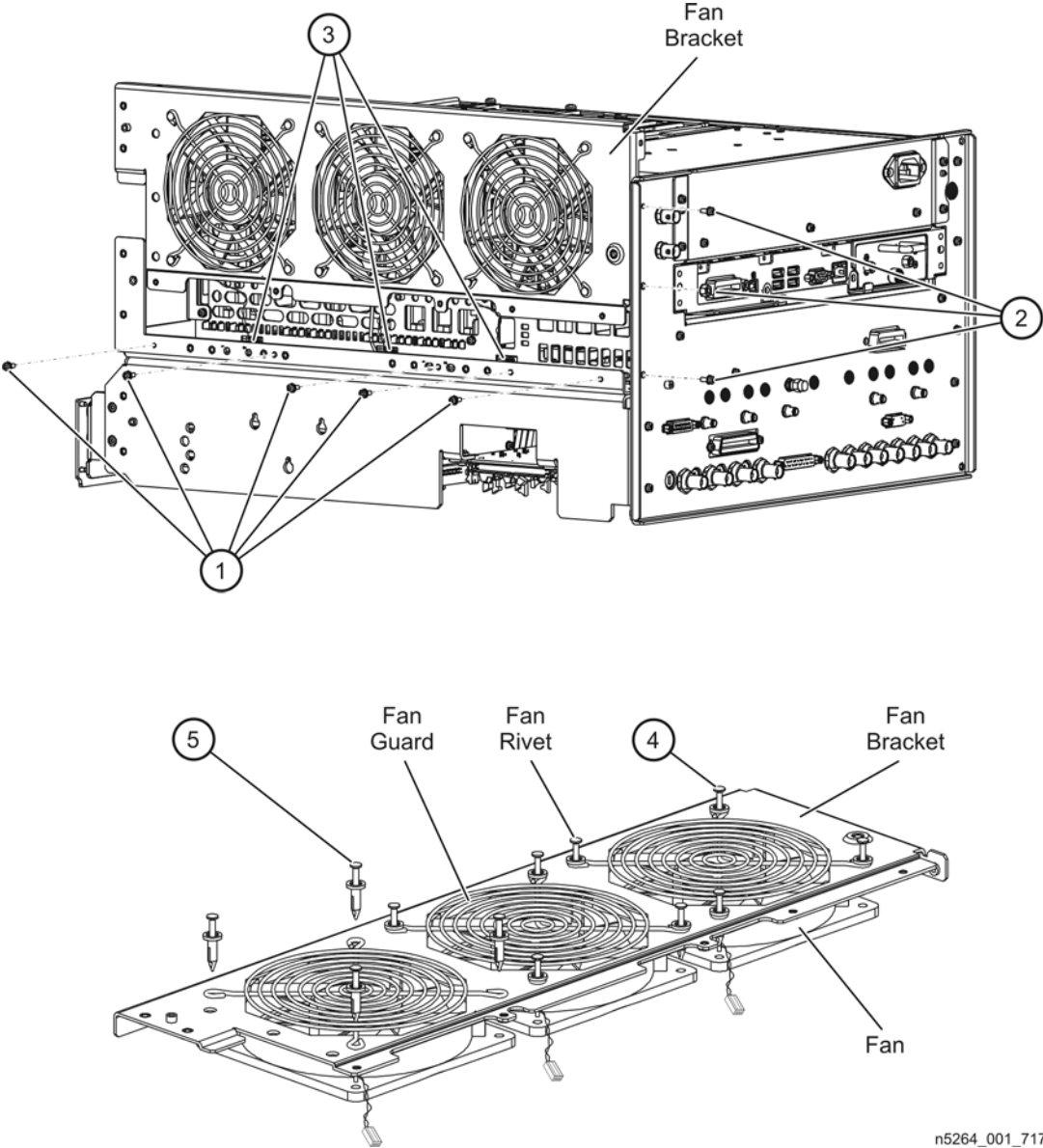

n5264_001_717

Removing and Replacing the Lithium Battery

Tools Required

- T-10 TORX driver (set to 9 in-lb)
- T-20 TORX driver (set to 21 in-lb)
- ESD grounding wrist strap

Removal Procedure

Refer to **Figure 7-23** for this procedure.

1. Disconnect the power cord.
2. Remove the A17 CPU board. Refer to **“Removing and Replacing the A17 CPU Board Assembly” on page 7-28**.
3. Remove top cover attachment screws (item ①) and (item ②).
4. Lift the top cover off of the CPU board assembly.
5. Remove the battery from the battery holder by lifting it at the open end of the holder and then sliding it from under the clip (item ③).
6. **DO NOT THROW AWAY THE BATTERY. COLLECT IT AS SMALL CHEMICAL WASTE.** Refer to **“Lithium Battery Disposal” on page 1-11** for additional information on battery disposal.

Replacement Procedure

1. Reverse the order of the removal procedure following all instructions included with the new battery.
2. Perform the post-repair adjustments, verifications, and performance tests that pertain to this removal procedure. Refer to **Table 7-2 on page 7-47**.

Figure 7-23 Lithium Battery Removal

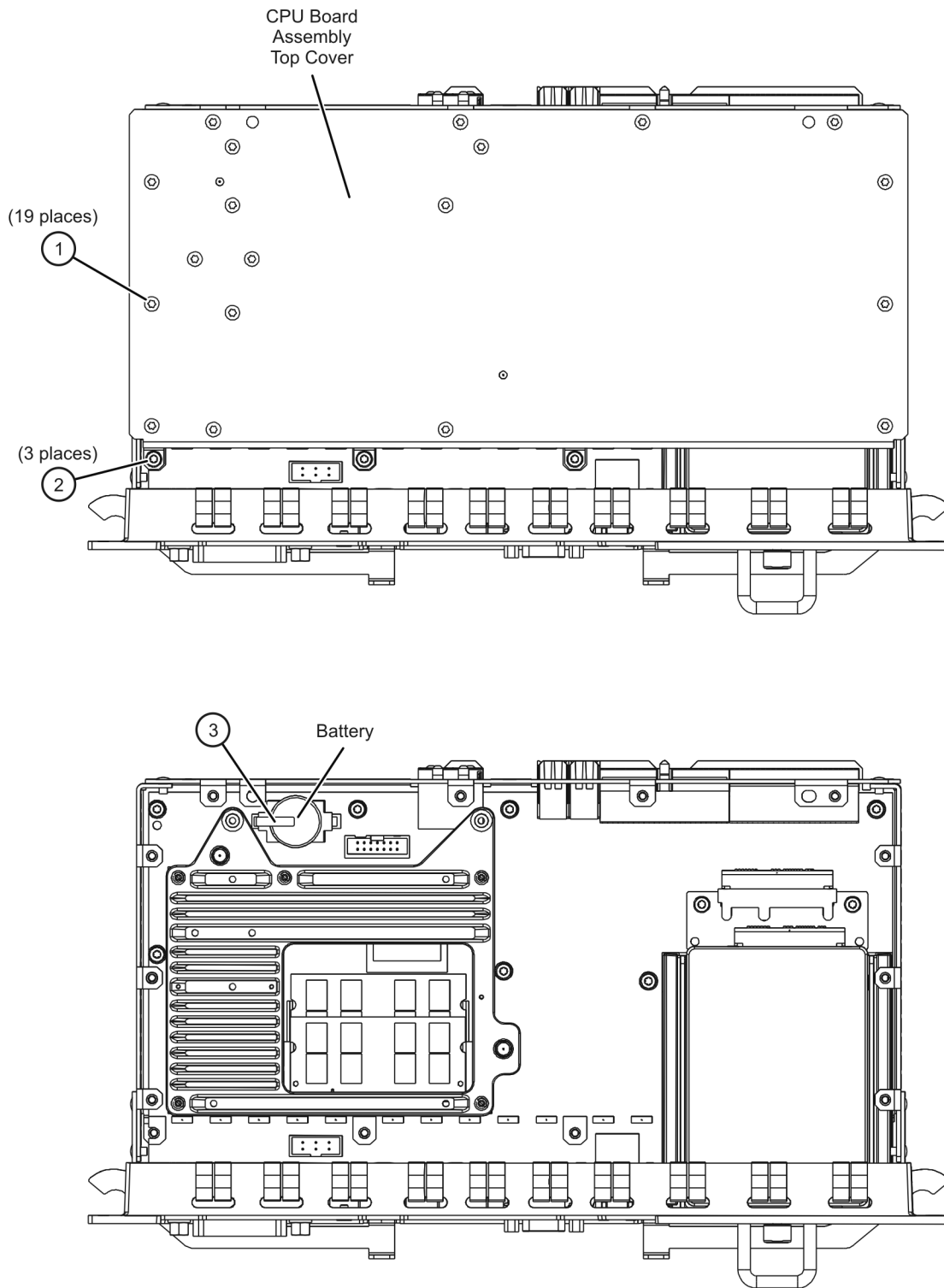

n5242_001_728.1

Post-Repair Procedures

After the replacement of an assembly, you must perform the service procedures in the order listed in [Table 7-2](#).

Procedures referenced in this table are located in [Chapter 3, “Tests and Adjustments,”](#) unless specified otherwise.

WARNING

STOP! Before returning the repaired instrument to the customer, it is critical to ensure the product is safe for use. Before powering on the instrument, verify there is ground continuity between the ground terminal on the AC Inlet and the metal frame of the product. It is also critical to perform a voltage test on the outer surfaces of the product to confirm the instrument does not present an electric shock hazard.

CAUTION

IMPORTANT! Before you begin any testing on a System or instrument, always inspect the connectors on the instrument, the calibration kit, cables and adapters.

NOTE

Keysight personnel: see [Figure 1-1 on page 1-6](#) to review where the calibration stickers should be placed on the PNA.

Table 7-2 Related Service Procedures

Replaced Assembly	Adjustments and Other Procedures	Verification, Performance, and Other Tests and Procedures
A1 front panel display board	No adjustment needed	Front Panel Keypad and RPG Test and A3 Display Test in Chapter 4
A2 USB board	No adjustment needed	Check for proper operation
A3 display assembly	Touchscreen Adjustment and Verification	A3 Display Test in Chapter 4
A10 frequency reference board	10 MHz Frequency Reference Adjustment (<6021 S/N Prefixes Only) Restore option data (Refer to “Repairing and Recovering Option Data” in Chapter 8 .)	
A11 fractional-N synthesizer board (Option 108)	EE Default Adjustment (Option 108) Synthesizer Bandwidth Adjustment (Option 108)	None needed
A12 SPAM board	No adjustment needed	None needed

Table 7-2 Related Service Procedures (Continued)

Replaced Assembly	Adjustments and Other Procedures	Verification, Performance, and Other Tests and Procedures
A14 system motherboard	No adjustment needed	Front Panel Keypad and RPG Test and A3 Display Test in Chapter 4
A15 midplane board	No adjustment needed	None needed
A16 power supply assembly	No adjustment needed	None needed
A17 CPU board	No adjustment needed	None needed
A18 GPIB board	No adjustment needed	None needed
A19 test set motherboard	Reinstall the serial number. (Refer to “Installing or Changing a Serial Number” in Chapter 8 .) Re-enable all hardware options. (Refer to “Software Entitlement Certificate” in Chapter 8 .)	None needed
A20 IF multiplexer board	None needed	None needed
A21 HMA26.5 (Option 108)	EE Default Adjustment (Option 108)	None needed
A51 hard disk drive	None needed	Read and write to the drive
B1 fan	No adjustment needed	Check for fan operation
Battery	No adjustment needed	None

8 General Purpose Maintenance Procedures

Information in This Chapter

Chapter Eight at-a-Glance

Section Title	Summary of Content	Start Page
Keysight License Manager	How to use the option enable utility to: <ul style="list-style-type: none">– enable options that have been added to your measurement receiver,– repair lost or damaged option data,– install or change a serial number.	page 8-2
Firmware Upgrades	How to check your measurement receiver's current firmware revision and where to locate firmware upgrades.	page 8-4
Operating System Recovery	Where to find the information on recovering from a damaged operating system.	page 8-5

Conventions Used for Hardkeys, Softkeys, and Menu Items

The following conventions are used in this document:

Hardkey

This represents a “hardkey”, a key that is physically located on the instrument.

Tab

This represents a “tab”, whose label is determined by the instrument firmware.

Softkey

This represents a “softkey”, a key whose label is determined by the instrument firmware.

Menu Item

This represents an item in a drop-down or pop-up menu.

Keysight License Manager

Accessing the Keysight License Manager

To start the Keysight License Manager:

- Press **Start** > **Keysight License Manager** > **Keysight License Manager**. A Keysight License Manager dialog box will appear.

Figure 8-1 Keysight License Manager Window

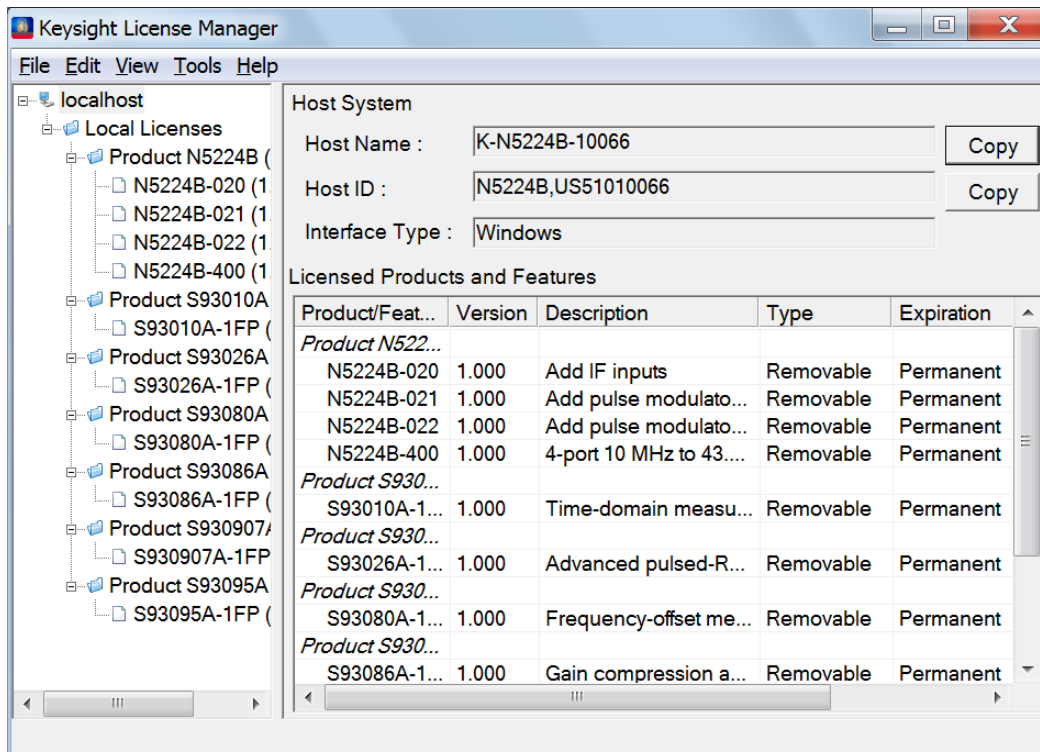

Software Entitlement Certificate

If you have received an "Software Entitlement Certificate", follow the instructions on the certificate, under "HOW TO USE THIS CERTIFICATE:", to obtain license key file(s) for the option(s) listed on the certificate. See the important note below.

NOTE

When upgrading from one model number to another, a new software entitlement certificate will be issued. When the new certificate is redeemed for a license key file, the automated system will ask for the instrument's Host ID. Be sure to use the old Host ID that is associated with the old model number.

Enabling or Removing Options

There are two types of options:

- **Hardware:** Hardware options involve adding additional hardware to the analyzer. After the proper hardware has been installed in the analyzer, the appropriate license can be installed using the Keysight License Manager.

It is necessary to re-enable all installed hardware options, if the midplane board is replaced.

- **Software:** Software options add features or functionality to the analyzer without the need for additional hardware. These options are enabled by installing the appropriate licenses using the Keysight License Manager (KLM). Refer to <https://www.keysight.com/us/en/assets/9018-04534/installation-guides/9018-04534.pdf> (N5242-90024).

NOTE

Some applications require a license key file that is provided by Keysight. If you do not have the required license key file, contact Keysight for assistance. Refer to [“Contacting Keysight” on page 2-8](#).

To enable or remove an option:

1. Start the Keysight License Manager. Refer to [“Accessing the Keysight License Manager” on page 8-2](#).
2. In the Keysight License Manager window that opens, in the left hand column, press **Local host > Local licenses**. A list of available options, similar to the list below, will appear. Refer to [Figure 8-1 on page 8-2](#).

S93010A - Time domain analysis

S93118A - Fast CW measurements

3. Press and hold (or right click with a mouse) the option that you wish to either enable or remove, and then click **Install** or **Delete**, whichever is appropriate.

Repairing and Recovering Option Data

For information on repairing or recovering option data, refer to Keysight License Manager help on your instrument.

Installing or Changing a Serial Number

It is necessary to reinstall the instrument serial number if the test set midplane board is replaced.

NOTE

To change an incorrect serial number, it is necessary for your instrument to be connected directly to the LAN and to a Keysight IP network. Refer to [“Contacting Keysight” on page 2-8](#).

Firmware Upgrades

How to Check the Current Firmware Version

1. Press UTILITY **System** , then **Help** , then **About NA...** .

A dialog box showing the current installed Application Code Version is displayed.

2. To determine if a firmware update is available, proceed to **“Downloading from the Internet.”**

Downloading from the Internet

If your measurement receiver is connected to the Internet, there are two methods available for checking the availability of, and downloading, new firmware:

- Download directly from <https://www.keysight.com/us/en/support/N5231B/pna-l-microwave-net-work-analyzer-13-5-ghz.html> or <https://www.keysight.com/us/en/product/N5232B/pna-l-microwave-net-work-analyzer-20-ghz.html> or refer to **“Contacting Keysight”** on page 2-8. (Select your measurement receiver’s model number in this web site to view available upgrades.)
- Press UTILITY **System** , then **Service** , then **AgileUpdate** .

AgileUpdate compares the firmware revision currently installed in your measurement receiver to the latest version available and assists you in downloading and installing the most recent version.

Operating System Recovery

Recovering from Hard Disk Drive Problems

If you suspect that you have a hard disk drive problem, go to the “Hard Drive Recovery” link on the Keysight PNA Series: Service & Support Home Page on the Internet.

The URL for the Keysight PNA Series: Service & Support Home Page is:

<http://mktwww.srs.is.keysight.com/field/service/network/pna/>

The URL for the Hard Drive Recovery page is:

<http://na.support.keysight.com/pna/hdrecovery.html>

General Purpose Maintenance Procedures
Operating System Recovery

Index

Numerics

- 13.5 GHz LO synthesizer board
 - illustrated, 6-14
 - operation, 5-7
 - part number, 6-12
 - removal and replacement
 - illustrated, 7-18, 7-20
 - procedure, 7-17, 7-19

A

- A1 front panel interface board
 - illustrated, 6-10
 - operation, 5-16
 - part number, 6-7
 - removal and replacement
 - illustrated, 7-12
 - procedure, 7-9
 - troubleshooting, 4-14, 4-16
- A10 frequency reference board
 - illustrated, 6-14
 - operation, 5-6
 - part number, 6-12
 - removal and replacement
 - illustrated, 7-18, 7-20
 - procedure, 7-17, 7-19
- A11 13.5 GHz LO synthesizer board
 - illustrated, 6-14
 - operation, 5-7
 - part number, 6-12
 - removal and replacement
 - illustrated, 7-18, 7-20
 - procedure, 7-17, 7-19
- A12 SPAM board
 - illustrated, 6-14
 - operation, 5-17
 - part number, 6-12
 - removal and replacement
 - illustrated, 7-18, 7-20
 - procedure, 7-17, 7-19
- A14 system motherboard
 - illustrated, 6-14
 - operation, 5-16

- part number, 6-12
- removal and replacement
 - illustrated, 7-23
 - procedure, 7-21
- A15 midplane board
 - illustrated, 6-14
 - part number, 6-12
 - removal and replacement
 - illustrated, 7-25
 - procedure, 7-24
- A16 power supply assembly
 - illustrated, 6-14
 - operation, 5-19
 - part number, 6-12
 - removal and replacement
 - illustrated, 7-27
 - procedure, 7-26
 - troubleshooting, 4-9
- A17 CPU board
 - illustrated, 6-14
 - operation, 5-17
 - part number, 6-12
 - removal and replacement
 - illustrated, 7-29
 - procedure, 7-28
 - troubleshooting, 4-23
- A18 GPIB board
 - illustrated, 6-14
 - part number, 6-12
 - removal and replacement
 - illustrated, 7-31
 - procedure, 7-30
- A19 test set motherboard
 - illustrated, 6-19
 - operation, 5-7
 - part number, 6-18
 - removal and replacement
 - illustrated, 7-34
 - procedure, 7-32
- A2 USB board
 - illustrated, 6-10
 - part number, 6-7
 - removal and replacement
 - illustrated, 7-12

- procedure, 7-9
- troubleshooting, 4-16
- A20 IF multiplexer board
 - illustrated, 6-19
 - operation, 5-12
 - part number, 6-18
 - removal and replacement
 - illustrated, 7-36
 - procedure, 7-35
- A21 HMA26.5
 - illustrated, 6-19
 - operation, 5-7
 - part number, 6-18
 - removal and replacement
 - illustrated, 7-38
 - procedure, 7-37
- A3 display assembly
 - illustrated, 6-10
 - operation, 5-16
 - part number, 6-7
 - removal and replacement
 - procedure, 7-11
 - troubleshooting, 4-14, 4-16
- A51 solid state drive
 - illustrated, 6-14
 - operation, 5-18
 - part number, 6-12
 - removal and replacement
 - procedure, 7-39
- accessories
 - analyzer, 2-3
 - USB
 - part numbers, 6-33
- adapters
 - required for servicing, 2-6
- adding
 - options, 8-3
- adjustment
 - touchscreen, 3-5
- adjustments
 - EE default, 3-7
 - frequency
 - at 10 MHz, 3-6
 - synthesizer bandwidth, 3-7
 - system, 3-1, 3-5

- getting ready, 3-2
- agile update
 - downloading firmware from the internet, 8-4
- analyzer
 - accessories, 2-3
 - block diagram
 - digital control group, 5-15
 - digital processor group, 5-15
 - IF multiplexer group, 5-13
- covers
 - illustrated, 6-29
 - part numbers, 6-28
 - removal and replacement, 7-5
- external replaceable parts
 - illustrated, 6-29
 - part numbers, 6-28
- feet
 - illustrated, 6-29
 - part numbers, 6-28
- front panel
 - interconnects, 5-16
- internal replaceable parts
 - illustrated, 6-27
 - part numbers, 6-26
- miscellaneous replaceable parts
 - part numbers, 6-32
- operation
 - keypad assembly, 5-17
 - main RAM, 5-18
- rear panel
 - interconnects, 5-7, 5-18
- rear panel replaceable parts
 - illustrated, 6-31
 - part numbers, 6-30
- strap handle
 - illustrated, 6-29
 - part number, 6-28
- upgrades, 2-3
- warmup time, 3-3
- assemblies
 - location of part numbers, 6-4
 - replacement list of procedures, 7-4
- sequence, 6-3
- attenuators
 - required for servicing, 2-6
- B
- B1 fan
 - removal and replacement illustrated, 7-44
 - procedure, 7-43
- bandwidth, synthesizer
 - adjustment, 3-7
- battery
 - disposal, 1-11
 - illustrated, 6-14
 - part number, 6-12, 6-32
 - removal and replacement illustrated, 7-46
 - procedure, 7-45
- before applying power, 1-3
- block diagram
 - digital control group, 5-15
 - digital processor group, 5-15
 - IF multiplexer group, 5-13
- bottom assembly, all options hardware
 - illustrated, 6-25
 - part numbers, 6-24
- replaceable assemblies
 - illustrated, 6-19
 - part numbers, 6-18
- replaceable RF cables
 - illustrated, 6-21
 - part numbers, 6-20
- replaceable ribbon cables
 - part numbers, 6-20
- replaceable ribbon wire harnesses
 - part numbers, 6-20
- C
- cables
 - GPIB
 - part numbers, 6-32
 - required for servicing, 2-6
 - RF
 - in bottom assembly, *See bottom assembly, all*
- options, 6-20
- in top assembly, all options, *See top assembly, all options, 6-16*
- ribbon
 - in bottom assembly, *See bottom assembly, all options, 6-20*
 - in top assembly, *See top assembly, all options, 6-16*
- wire harnesses
 - in bottom assembly, *See bottom assembly, all options, 6-20*
 - in top assembly, all options, *See top assembly, all options, 6-16*
- calibration
 - kits, 2-5
 - touchscreen, 3-5
- care of connectors, 3-3
- caution, 1-2
- changing
 - a serial number, 8-3
- channel, *See receiver*
- checks
 - system, 3-1
 - getting ready, 3-2
- connectors
 - care
 - principles of, 3-3
 - quick reference, 3-3
 - care of, 3-3
 - front panel, 5-16
 - rear panel, 5-7, 5-8, 5-18
 - Display, 5-18
 - EXT 10 MHz REF IN, 5-7
 - EXT 10 MHz REF OUT, 5-7

- GPIB, 5-18
 - HANDLER I/O, 5-8, 5-9
 - PWR I/O, 5-10
 - TEST SET I/O, 5-8
 - USB, 5-18
 - VGA, 5-18
- contacting Keysight, 2-8
- controllers
 - troubleshooting with, 4-24
- covers, analyzer
 - illustrated, 6-29
 - part numbers, 6-28
 - removal and replacement
 - illustrated, 7-6
 - procedure, 7-5
 - removal warning, 1-5
- CPU board
 - illustrated, 6-14
 - operation, 5-17
 - part number, 6-12
 - removal and replacement
 - illustrated, 7-29
 - procedure, 7-28
 - troubleshooting, 4-23
- cross-over cable, LAN, 4-27
- D
 - dangerous voltage, 1-5
 - data
 - option
 - recovering, 8-3
 - repairing, 8-3
 - storage
 - hard disk, 5-18
 - IDE, 5-18
 - data acquisition and processing
 - operation, 5-17
 - subgroup, 5-12, 5-14
 - default, EE
 - adjustment, 3-7
 - description
 - functional
 - digital control group, 5-3
 - digital processing group, 5-3
 - IF multiplexer, 5-3
 - IF multiplexer
 - group, 5-3
 - power supply group, 5-3
 - synthesized LO group, 5-3
 - digital control group
 - block diagram, 5-15
 - functional description of, 5-3
 - operation, 5-14
 - disabling
 - options, 8-3
 - display
 - assembly
 - illustrated, 6-10
 - operation, 5-16
 - parts list, 6-7
 - troubleshooting, 4-14, 4-16
 - port
 - rear panel connector, 5-18
 - display assembly
 - removal and replacement procedure, 7-11
 - display cable
 - removal and replacement procedure, 7-11
 - display test
 - running, 4-20
 - documentation
 - part numbers, 6-32
 - dress panel
 - lower front panel
 - illustrated, 6-7
 - part number, 6-6
- E
 - earth ground, 1-3
 - EE default
 - adjustment, 3-7
 - electrostatic discharge, *See ESD*
 - enabling
 - options, 8-3
 - entitlement certificate,
 - option, 8-2
 - environment, operating specifications, 3-2
 - verification, 3-2
 - equipment
 - service test
 - required, 2-5
- ESD
 - protection, 1-7, 3-3, 4-3, 4-4, 7-3
 - supplies
 - part numbers, 6-33
- EXT 10 MHz REF IN connector
 - rear panel, 5-7
- EXT 10 MHz REF OUT
 - connector
 - rear panel, 5-7
- external
 - analyzer
 - replaceable parts, 6-28, 6-29
 - monitor, 4-15
- F
 - fan
 - bracket
 - removal and replacement, 7-43, 7-44
 - removal and replacement
 - illustrated, 7-44
 - procedure, 7-43
 - troubleshooting, 4-13
 - feet
 - analyzer
 - illustrated, 6-29
 - part numbers, 6-28
 - firmware
 - checking current version, 8-4
 - upgrades, 8-4
 - frequency
 - adjustment
 - at 10 MHz, 3-6
 - reference board
 - illustrated, 6-14
 - operation, 5-6
 - part number, 6-12
 - removal and replacement, 7-17, 7-18, 7-19, 7-20
 - front frame
 - illustrated, 6-7
 - part number, 6-6
 - front panel
 - assembly
 - replaceable parts, 6-6,

- 6-7, 6-10
- assembly, removal and replacement
 - illustrated, 7-8
 - procedure, 7-7
- display assembly
 - illustrated, 6-10
 - parts list, 6-7
- display board
 - operation, 5-16
- front frame
 - illustrated, 6-7
 - part number, 6-6
- interconnects, 5-16
- interface board
 - illustrated, 6-10
 - part number, 6-7
 - replacement, 7-9, 7-12
 - troubleshooting, 4-14, 4-16
- inverter board
 - illustrated, 6-10
 - part number, 6-7
- keypad assembly
 - illustrated, 6-10
 - parts list, 6-7
 - replacement, 7-12
 - troubleshooting, 4-16
- knob
 - illustrated, 6-7
 - part number, 6-6
 - test, 4-19
 - troubleshooting, 4-16
- LCD assembly
 - illustrated, 6-10
 - parts list, 6-7
- LED board
 - illustrated, 6-19, 6-25
 - part number, 6-18, 6-24
- lower dress panel
 - illustrated, 6-7
 - part number, 6-6
- lower overlay
 - illustrated, 6-7
 - part number, 6-6
- nameplate
 - illustrated, 6-7
 - part number, 6-6
- operation, 5-16

- power switch board
 - illustrated, 6-10
 - parts list, 6-7
- power switch overlay
 - illustrated, 6-7
 - part number, 6-6
- subassemblies, removal and replacement
 - illustrated, 7-12
 - procedures, 7-9
- subgroup, 5-14
- touch screen
 - illustrated, 6-10
 - parts list, 6-7
- trim strip, filler
 - illustrated, 6-7
 - part number, 6-6
- troubleshooting, 4-16
- USB board
 - illustrated, 6-10
 - part number, 6-7
- USB controller board
 - illustrated, 6-10
 - part number, 6-7
- functional groups, 5-2
- fuses, 6-32
- G
- general safety
 - considerations, 1-3
- government
 - regulatory information, 1-9
- GPIO
 - board
 - illustrated, 6-14
 - part number, 6-12
 - removal and replacement, 7-30, 7-31
 - cables
 - part numbers, 6-32
 - CONTROLLER
 - port, 4-23
 - systems check, 4-23
 - port
 - rear panel connector, 5-18
- ground, safety earth, 1-3
- groups

- functional, 5-2
- H
- handle
 - damaged, 1-3
- HANDLER I/O
 - connector
 - pin assignments, 5-9
 - rear panel, 5-8
- hardware
 - in bottom assembly
 - illustrated, 6-25
 - part numbers, 6-24
 - in external analyzer
 - illustrated, 6-29
 - part numbers, 6-28
 - in internal analyzer
 - illustrated, 6-27
 - part numbers, 6-26
 - in rear panel assembly
 - illustrated, 6-31
 - part numbers, 6-30
 - in top assembly
 - illustrated, 6-22, 6-23
 - part numbers, 6-22
 - location of part numbers, 6-5
 - options, 8-3
 - upgrades, 2-4
- HDD, *See solid state drive*
- HMA26.5
 - illustrated, 6-19
 - operation, 5-7
 - part number, 6-18
 - removal and replacement
 - illustrated, 7-38
 - procedure, 7-37
- I
- IDE
 - data storage, 5-18
- IF inputs
 - operation, 5-12
- IF multiplexer
 - block diagram, 5-13
- board
 - illustrated, 6-19
 - operation, 5-12
 - part number, 6-18

- removal and replacement, 7-35, 7-36
 - functional description of, 5-3
 - group
 - operation, 5-12
- IF multiplexer group
 - block diagram, 5-13
- installing
 - a serial number, 8-3
- interconnects
 - front panel, 5-16
 - HANDLER I/O
 - pin assignments, 5-9
 - PWR I/O
 - pin assignments, 5-10
 - rear panel, 5-7, 5-8, 5-18
 - Display, 5-18
 - EXT 10 MHz REF IN, 5-7
 - EXT 10 MHz REF OUT, 5-7
 - GPIO, 5-18
 - HANDLER I/O, 5-8
 - LAN, 5-18
 - TEST SET I/O, 5-8
 - USB, 5-18
 - VGA, 5-18
 - TEST SET I/O
 - pin assignments, 5-8
- internal analyzer
 - replaceable hardware
 - illustrated, 6-27
 - part numbers, 6-26
 - replaceable parts
 - illustrated, 6-27
 - part numbers, 6-26
- inverter board
 - illustrated, 6-10
 - part number, 6-7
 - removal and replacement
 - illustrated, 7-12
 - procedure, 7-10
 - troubleshooting, 4-14
- IP address, LAN, 4-25
- K
 - keypad assembly
 - illustrated, 6-10
 - operation, 5-17
 - parts list, 6-7
 - replacement
 - illustrated, 7-12
 - procedure, 7-9
 - test, 4-17
 - troubleshooting, 4-16
- Keysight
 - contacting, 2-8
 - License Manager, 8-2
 - support, 2-8
- kits
 - calibration, 2-5
 - rack mount
 - part numbers, 6-33
 - upgrade
 - order numbers, 6-32
 - part numbers, 6-32
 - verification, 2-5
- knob
 - front panel
 - illustrated, 6-7
 - part number, 6-6
 - test, 4-19
 - troubleshooting, 4-16
- L
 - LAN
 - connector
 - rear panel, 5-18
 - cross-over cable, 4-27
 - IP address, 4-25
 - ping command, 4-25
 - ping to and from, 4-24
 - subnet mask, 4-25
 - testing between
 - analyzers, 4-27
 - troubleshooting, 4-24
 - LCD assembly
 - illustrated, 6-10
 - parts list, 6-7
 - LED board
 - illustrated, 6-19, 6-25
 - part number, 6-18, 6-24
 - License Manager, Keysight
 - option enable, 8-2
 - accessing, 8-2
 - lithium battery
 - disposal, 1-11
 - removal and replacement
 - illustrated, 7-46
 - LO
 - procedure, 7-45
- LO
 - functional group, 5-2
 - synthesizer board
 - removal and replacement, 7-17, 7-18, 7-19, 7-20
- locating
 - assembly part numbers, 6-4
 - hardware part numbers, 6-5
 - miscellaneous part numbers, 6-5
 - replaceable part numbers
 - by reference designator, 6-4
 - by type of part, 6-4
- M
 - machine screws
 - in bottom assemblies
 - illustrated, 6-25
 - part numbers, 6-24
 - in external analyzer
 - illustrated, 6-29
 - part numbers, 6-28
 - in rear panel assembly
 - illustrated, 6-31
 - part numbers, 6-30
 - maintenance
 - cleaning, 2-2
 - measurement receiver
 - frequency reference board assembly, 5-6
 - functional groups, 5-2
 - digital control, 5-3
 - digital processing, 5-3
 - IF multiplexer, 5-3
 - power supply, 5-3
 - synthesized source, 5-3
 - operation
 - 13.5 GHz LO synthesizer board, 5-7
 - CPU board, 5-17
 - data acquisition subgroup, 5-17
 - digital control group, 5-14
 - digital processor group, 5-14

- display assembly, 5-16
- front panel display board, 5-16
- front panel subgroup, 5-16
- HMA 26.5, 5-7
- IF inputs, 5-12
- IF multiplexer board, 5-12
- IF multiplexer group, 5-12
- power supply group, 5-19
- processing subgroup, 5-17
- solid state drive, 5-18
- SPAM board, 5-17
- synthesized LO group, 5-4
- test set motherboard, 5-7
- rear panel interconnects, 5-8
- system block diagram, 5-2
- system operation theory of, 5-2
- upgrades, 2-4
- memory modules part numbers, 6-32
- midplane board illustrated, 6-14
- part number, 6-12
- removal and replacement illustrated, 7-25
- procedure, 7-24
- miscellaneous replaceable parts location of part numbers, 6-5
- part numbers, 6-32
- required for servicing, 2-7
- monitor, external, 4-15
- motherboard, system, *See* A14
- motherboard, test set, *See* A19
- N
- N1966A pulse I/O adapter, 2-3
- nameplate front panel illustrated, 6-7
- part number, 6-6
- network analyzer, *See* analyzer
- O
- OCXO (oven-controlled crystal oscillator) frequency adjustment, 3-6
- theory of operation, 5-6
- operating environment specifications, 3-2
- verification, 3-2
- system recovery, 8-5
- operation 13.5 GHz LO synthesizer board, 5-7
- CPU board, 5-17
- data acquisition, 5-17
- digital control, 5-14
- digital processor, 5-14
- display assembly, 5-16
- frequency reference board, 5-6
- front panel, 5-16
- front panel display board, 5-16
- HMA 26.5, 5-7
- IF inputs, 5-12
- IF multiplexer board, 5-12
- IF multiplexer group, 5-12
- keypad assembly, 5-17
- LO group, 5-4
- main RAM, 5-18
- power supply, 5-19
- processing subgroup, 5-17
- solid state drive, 5-18
- SPAM board, 5-17
- system motherboard, 5-16
- test set motherboard, 5-7
- option data recovering, 8-3
- repairing, 8-3
- enable License Manager, Keysight, 8-2
- enabling and removing, 8-3
- entitlement certificate, 8-2
- hardware, 8-3
- Keysight License Manager accessing, 8-2
- service and support, 2-8
- software, 8-3
- ordering information options and upgrades, 2-3
- replaceable parts, 6-2
- overlay lower front panel illustrated, 6-7
- part number, 6-6
- power switch part number, 6-6, 6-7
- P
- pads required for servicing, 2-6
- paint touch-up part numbers, 6-33
- part numbers, *See* section in Chapter 6 titled *Replaceable Parts Listings*
- parts in bottom assembly illustrated, 6-25
- part numbers, 6-24
- in external analyzer illustrated, 6-29
- part numbers, 6-28
- in internal analyzer illustrated, 6-27
- part numbers, 6-26
- in rear panel assembly illustrated, 6-31
- part numbers, 6-30
- in top assembly, all options illustrated, 6-22, 6-23
- miscellaneous part numbers, 6-32
- required for servicing, 2-7
- pin assignments

- connectors
 - HANDLER I/O, 5-9
 - PWR I/O, 5-10
 - TEST SET I/O, 5-8
- ping
 - command, LAN, 4-25
 - from network, 4-26
 - to analyzer, 4-25
- pixel
 - damaged, 4-20
 - definition, 4-20
- post-repair procedures, 7-47
- power button keypad
 - removal and replacement
 - illustrated, 7-12
 - procedure, 7-10
- power supply
 - check, 4-9
 - functional description of, 5-3
 - functional group, 5-2
- power supply assembly
 - part number, 6-12
- power supply, *See* A16
- power switch
 - board
 - illustrated, 6-10
 - parts list, 6-7
 - overlay
 - part number, 6-6, 6-7
- power switch board
 - removal and replacement
 - illustrated, 7-12
 - procedure, 7-10
- power up
 - troubleshooting, 4-8
- pre-repair
 - procedures
 - caution about, 7-2
 - warnings about, 7-2
- processing subgroup
 - operation, 5-17
- protection
 - against ESD, 1-7, 3-3, 4-3, 4-4, 7-3
- pulse I/O adapter, N1966A, 2-3
- PWR I/O
 - connector
 - pin assignments, 5-10

R

- rack mount kits
 - part numbers, 6-33
- RAM, main
 - operation, 5-18
- rear panel
 - connectors
 - Display, 5-18
 - EXT 10 MHz REF IN, 5-7
 - GPIB, 5-18
 - HANDLER I/O, 5-8
 - LAN, 5-18
 - TEST SET I/O, 5-8
 - USB, 5-18
 - VGA, 5-18
 - interconnects, 5-7, 5-8, 5-18
 - removal and replacement
 - illustrated, 7-42
 - procedure, 7-41
 - replaceable parts
 - illustrated, 6-31
 - part numbers, 6-30
 - troubleshooting, 4-23
 - USB
 - troubleshooting, 4-23
- receiver
 - functional group, 5-2
- recovery
 - operating system, 8-5
 - option data, 8-3
- regulatory information, 1-9
- removing
 - assemblies, *See specific assembly.*
 - cover, 1-5
 - options, 8-3
 - parts, *See specific part.*
- repair
 - option data, 8-3
 - post-repair procedures, 7-47
 - procedures
 - caution about, 7-2
 - warnings about, 7-2
- replaceable cables, ribbon,
 - See cables, ribbon, 6-16*
- replaceable cables, *See cables, wire harnesses, 6-16*

- replaceable hardware
 - in bottom assembly
 - illustrated, 6-25
 - part numbers, 6-24
 - in external analyzer
 - illustrated, 6-29
 - part numbers, 6-28
 - in internal analyzer
 - illustrated, 6-27
 - part numbers, 6-26
 - in rear panel assembly
 - illustrated, 6-31
 - part numbers, 6-30
 - in top assembly
 - illustrated, 6-22, 6-23
 - part numbers, 6-22
- replacement
 - A1 front panel interface board
 - illustrated, 7-12
 - procedure, 7-9
 - A2 USB board
 - illustrated, 7-12
 - procedure, 7-9
 - A3 display assembly
 - procedure, 7-11
- assembly
 - sequence, 6-3
- display cable
 - procedure, 7-11
- front panel assembly
 - procedure, 7-7
- front panel subassemblies
 - illustrated, 7-12
 - procedures, 7-9
- inverter board
 - illustrated, 7-12
 - procedure, 7-10
- keypad assembly
 - illustrated, 7-12
 - procedure, 7-9
- power button keypad
 - illustrated, 7-12
 - procedure, 7-10
- power switch board
 - illustrated, 7-12
 - procedure, 7-10
- touch screen
 - procedure, 7-11
- USB controller board

- illustrated, 7-12
 - procedure, 7-10
- replacement sequence, 4-5
- replacement, *See section in Chapter 7 titled Removal and Replacement Procedures*, 7-4
- RF cables
 - in bottom assembly, all options
 - illustrated, 6-21
- RF cables, *See cables, RF*
- ribbon cables, *See cables, ribbon*
- rotary pulse generator (RPG)
 - illustrated, 6-7
 - part number, 6-6
 - test, 4-19
 - troubleshooting, 4-16

S

- safety
 - considerations, 1-3
 - earth ground, 1-3
 - symbols, 1-2
- screws
 - for bottom assemblies
 - illustrated, 6-25
 - part numbers, 6-24
 - in external analyzer
 - illustrated, 6-29
 - part numbers, 6-28
 - in rear panel assembly
 - illustrated, 6-31
 - part numbers, 6-30
- serial number
 - changing, 8-3
 - installing, 8-3
- service
 - battery
 - part numbers, 6-32
 - contacting Keysight, 2-8
 - memory modules
 - part numbers, 6-32
 - miscellaneous parts
 - required, 2-7
 - options, 2-8
 - procedures
 - caution about, 7-2

- post-repair, 7-47
 - warnings about, 7-2
- static safety parts
 - part numbers, 6-33
 - required, 2-7
- test equipment
 - required, 2-5
- tools
 - part numbers, 6-32
 - required, 2-6
- warnings, 1-5
- warranty
 - one-year return to Keysight, 2-8
 - standard, 2-8
- shipment for service or repair, 2-9
- signal processing ADC module (SPAM) board
 - illustrated, 6-14
 - part number, 6-12
- software
 - options, 8-3
- solid state drive
 - copying files from, 7-39
 - data storage, 5-18
 - illustrated, 6-14
 - operation, 5-18
 - part number, 6-12
 - removal and replacement
 - illustrated, 7-40
 - procedure, 7-39
 - unique files located on, 7-39
- SPAM board
 - illustrated, 6-14
 - operation, 5-17
 - part number, 6-12
 - removal and replacement
 - illustrated, 7-18, 7-20
 - procedure, 7-17, 7-19
- speaker
 - troubleshooting, 4-16
- specifications
 - stabilization, warm up time, 3-3
- SSD, *See solid state drive*
- stabilization
 - warm up time, 3-3
- static safety parts
 - required for servicing, 2-7

- storage data
 - IDE, 5-18
- strap handle
 - analyzer
 - illustrated, 6-29
 - part number, 6-28
- subgroup
 - data acquisition and processing, 5-12, 5-14
 - front panel, 5-14
 - subnet mask, LAN, 4-25
- supplies
 - battery
 - part number, 6-32
 - ESD
 - part numbers, 6-33
 - memory modules
 - part numbers, 6-32
- support
 - contacting Keysight, 2-8
 - options, 2-8
 - organization, 2-8
- synthesized LO
 - functional description of, 5-3
 - operation, 5-4
- synthesizer bandwidth
 - adjustment, 3-7
- system
 - adjustments, 3-1
 - EE default, 3-7
 - frequency at 10 MHz, 3-6
 - getting ready, 3-2
 - synthesizer bandwidth, 3-7
 - checks, 3-1
 - getting ready, 3-2
 - operating, recovery, 8-5
 - verification, 3-1
 - getting ready, 3-2
- system motherboard, *See A14*, 5-16

T

- test
 - adjustments, 3-5
 - equipment
 - required for service, 2-5
 - required for servicing, 2-5

- TEST SET I/O
 - connector
 - pin assignments, 5-8
 - rear panel, 5-8
 - test set motherboard
 - illustrated, 6-19
 - operation, 5-7
 - part number, 6-18
 - removal and replacement
 - illustrated, 7-34
 - procedure, 7-32
 - tools
 - required for servicing, 2-6
 - service, part numbers, 6-32
 - top assembly, all options
 - replaceable cables, all
 - illustrated, 6-17
 - part numbers, 6-16
 - touch screen
 - illustrated, 6-10
 - parts list, 6-7
 - removal and replacement
 - procedure, 7-11
 - touchscreen
 - adjustment, 3-5
 - calibration, 3-5
 - verification, 3-5
 - touch-up
 - paint
 - part numbers, 6-33
 - trim strip, filler
 - front panel
 - illustrated, 6-7
 - part number, 6-6
 - troubleshooting
 - A1 front panel interface
 - board, 4-14, 4-16
 - A16 power supply
 - assembly, 4-9
 - A17 CPU board, 4-23
 - A3 display assembly, 4-14, 4-16
 - check the basics, 4-6
 - fans, 4-13
 - front panel, 4-16
 - front panel keypad, 4-16
 - front panel knob, 4-16
 - front-panel USB, 4-16
 - GPIB CONTROLLER port, 4-23
 - inverter board, 4-14
 - LAN, 4-24
 - ping command, 4-25
 - power up, 4-8
 - power supply check, 4-9
 - rear panel, 4-23
 - rear-panel USB, 4-23
 - RPG, 4-16
 - speaker, 4-16
 - using controllers to system
 - troubleshoot, 4-24
 - where to begin, 4-6
 - U
 - upgrade
 - analyzer, 2-3
 - firmware, 8-4
 - downloading from the internet, 8-4
 - how to order, 2-3
 - kits
 - order numbers, 6-32
 - part numbers, 6-32
 - to measurement receiver, 2-4
 - USB
 - accessories
 - part numbers, 6-33
 - board
 - front panel,
 - illustrated, 6-10
 - front panel, part number, 6-7
 - controller board
 - front panel,
 - illustrated, 6-10
 - front panel, part number, 6-7
 - port
 - rear panel
 - connector, 5-18
 - rear panel
 - troubleshooting, 4-23
 - USB board
 - removal and replacement
 - illustrated, 7-12
 - procedure, 7-9
 - troubleshooting, 4-16
 - USB controller board
 - removal and replacement
 - illustrated, 7-12
 - procedure, 7-10
- V
 - VCO (voltage-controlled oscillator)
 - defined, 5-4
 - ventilation requirements, 1-3
 - verification
 - kits, 2-5
 - of operating environment, 3-2
 - of operating specifications, 3-2
 - system, 3-1
 - getting ready, 3-2
 - touchscreen, 3-5
- VGA
 - monitor, 4-15
 - port
 - rear panel
 - connector, 5-18
- W
 - warm up
 - analyzer, 3-3
 - warning, 1-2
 - for servicing, 1-5
 - warranty
 - service
 - one-year return to Keysight, 2-8
 - standard, 2-8
- Windows, 2-5
- wire harnesses, *See cables, wire harnesses*, 6-20



This information is subject to change without notice.

© Keysight Technologies 2011-2022

Edition 1, January 2022

N5264-90026

www.keysight.com