

User Guide

Keysight M9005A PXIe Chassis

Notices

© Keysight Technologies, Inc. 2016

No part of this manual may be reproduced in any form or by any means (including electronic storage and retrieval or translation into a foreign language) without prior agreement and written consent from Keysight Technologies, Inc. as governed by United States and international copyright laws.

Manual Part Number

M9005-90001

Edition

First Edition, July 2016

Published by

Keysight Technologies, Inc.
900 S. Taft Ave.
Loveland, CO 80537 USA

Trademarks

PICMG[®], Compact PCI[®] are registered trademarks of the PCI Industrial Computer Manufacturers Group.

AdvancedTCA[®] and ATCA are registered trademarks of the PCI Industrial Computer Manufacturers Group.

PCI-SIG[®], PCI Express[®], and PCIe[®] are registered trademarks of PCI-SIG.

Technology Licenses

The hardware and/or software described in this document are furnished under a license and may be used or copied only in accordance with the terms of such license.

Declaration of Conformity

Declarations of Conformity for this product and for other Keysight products may be downloaded from the Web. Go to <http://keysight.com/go/conformity>.

You can then search by product number to find the latest Declaration of Conformity.

U.S. Government Rights

The Software is “commercial computer software,” as defined by Federal Acquisition Regulation (“FAR”) 2.101. Pursuant to FAR 12.212 and 27.405-3 and Department of Defense FAR Supplement (“DFARS”) 227.7202, the U.S. government acquires commercial computer software under the same terms by which the software is customarily provided to the public. Accordingly, Keysight provides the Software to U.S. government customers under its standard commercial license, which is embodied in its End User License Agreement (EULA), a copy of which can be found at <http://www.keysight.com/find/sweula>. The license set forth in the EULA represents the exclusive authority by which the U.S. government may use, modify, distribute, or disclose the Software. The EULA and the license set forth therein, does not require or permit, among other things, that Keysight: (1) Furnish technical information related to commercial computer software or commercial computer software documentation that is not customarily provided to the public; or (2) Relinquish to, or otherwise provide, the government rights in excess of these rights customarily provided to the public to use, modify, reproduce, release, perform, display, or disclose commercial computer software or commercial computer software documentation. No additional government requirements beyond those set forth in the EULA shall apply, except to the extent that those terms, rights, or licenses are explicitly required from all providers of commercial computer software pursuant to the FAR and the DFARS and are set forth specifically in writing elsewhere in the EULA. Keysight shall be under no obligation to update, revise or otherwise modify the Software. With respect to any technical data as defined by FAR 2.101, pursuant to FAR 12.211 and 27.404.2 and DFARS 227.7102, the U.S. government acquires no greater than Limited Rights as defined in FAR 27.401 or DFARS 227.7103-5 (c), as applicable in any technical data.

Warranty

THE MATERIAL CONTAINED IN THIS DOCUMENT IS PROVIDED “AS IS,” AND IS SUBJECT TO BEING CHANGED, WITHOUT NOTICE, IN FUTURE EDITIONS. FURTHER, TO THE MAXIMUM EXTENT PERMITTED BY APPLICABLE LAW, KEYSIGHT DISCLAIMS ALL WARRANTIES, EITHER EXPRESS OR IMPLIED, WITH REGARD TO THIS MANUAL AND ANY INFORMATION CONTAINED HEREIN, INCLUDING BUT NOT LIMITED TO THE IMPLIED WARRANTIES OF MERCHANTABILITY AND FITNESS FOR A PARTICULAR PURPOSE. KEYSIGHT SHALL NOT BE LIABLE FOR ERRORS OR FOR INCIDENTAL OR CONSEQUENTIAL DAMAGES IN CONNECTION WITH THE FURNISHING, USE, OR PERFORMANCE OF THIS DOCUMENT OR OF ANY INFORMATION CONTAINED HEREIN. SHOULD KEYSIGHT AND THE USER HAVE A SEPARATE WRITTEN AGREEMENT WITH WARRANTY TERMS COVERING THE MATERIAL IN THIS DOCUMENT THAT CONFLICT WITH THESE TERMS, THE WARRANTY TERMS IN THE SEPARATE AGREEMENT SHALL CONTROL.

Keysight Technologies does not warrant third-party system-level (combination of chassis, controllers, modules, etc.) performance, safety, or regulatory compliance unless specifically stated.

Safety Information

The following general safety precautions must be observed during all phases of operation of this instrument. Failure to comply with these precautions or with specific warnings or operating instructions in the product manuals violates safety standards of design, manufacture, and intended use of the instrument. Keysight Technologies assumes no liability for the customer's failure to comply with these requirements.

General

Do not use this product in any manner not specified by the manufacturer. The protective features of this product must not be impaired if it is used in a manner specified in the operation instructions.

Before Applying Power

Verify that all safety precautions are taken. Make all connections to the unit before applying power. Note the external markings described under "Safety Symbols".

Ground the Instrument

Keysight chassis are provided with a grounding-type power plug. The instrument chassis and cover must be connected to an electrical ground to minimize shock hazard. The ground pin must be firmly connected to an electrical ground (safety ground) terminal at the power outlet. Any interruption of the protective (grounding) conductor or disconnection of the protective earth terminal will cause a potential shock hazard that could result in personal injury.

Do Not Operate in an Explosive Atmosphere

Do not operate the module/chassis in the presence of flammable gases or fumes.

Do Not Operate Near Flammable Liquids

Do not operate the module/chassis in the presence of flammable liquids or near containers of such liquids.

Cleaning

Clean the outside of the Keysight module/chassis with a soft, lint-free, slightly dampened cloth. Do not use detergent or chemical solvents.

Do Not Remove Instrument Cover

Only qualified, service-trained personnel who are aware of the hazards involved should remove instrument covers. Always disconnect the power cable and any external circuits before removing the instrument cover.

Keep Away From Live Circuits

Operating personnel must not remove equipment covers or shields. Procedures involving the removal of covers and shields are for use by service-trained personnel only. Under certain conditions, dangerous voltages may exist even with the equipment switched off. To avoid dangerous electrical shock, DO NOT perform procedures involving cover or shield removal unless you are qualified to do so.

Do NOT Operate Damaged Equipment

Whenever it is possible that the safety protection features built into this product have been impaired, either through physical damage, excessive moisture, or any other reason, REMOVE POWER and do not use the product until safe operation can be verified by service-trained personnel. If necessary, return the product to a Keysight Technologies Sales and Service Office for service and repair to ensure the safety features are maintained.

Do NOT Block The Primary Disconnect

The primary disconnect device is the appliance connector/power cord when a chassis used by itself, but when installed into a rack or system the disconnect may be impaired and must be considered part of the installation.

Do NOT Modify the Instrument

Do not install substitute parts or perform any unauthorized modification to the product. Return the product to a Keysight Sales and Service Office to ensure that safety features are maintained.

In Case of Damage

Instruments that appear damaged or defective should be made inoperative and secured against unintended operation until they can be repaired by qualified service personnel.

Safety Symbols







CAUTION

A CAUTION denotes a hazard. It calls attention to an operating procedure or practice, that, if not correctly performed or adhered to could result in damage to the product or loss of important data. Do not proceed beyond a CAUTION notice until the indicated conditions are fully understood and met.

WARNING

A WARNING denotes a hazard. It calls attention to an operating procedure or practice, that, if not correctly performed or adhered to, could result in personal injury or death. Do not proceed beyond a WARNING notice until the indicated conditions are fully understood and met.

Products display the following symbols:

-  Warning, risk of electric shock
-  Refer to manual for additional safety information.
-  Earth Ground.
-  Chassis Ground.
-  Alternating Current (AC).
-  Standby Power. Unit is not completely disconnected from AC mains when switch is in standby.
-  Antistatic precautions should be taken.
- CAT I IEC Measurement Category I, II, III, or IV
- CAT II
- CAT III
- CAT IV

For localized Safety Warnings, Refer to Keysight Safety document (p/n 9320-6792).



The UL Listing Mark indicates this product is Listed to applicable UL Standards and requirements by UL. Refer to the product Declaration of Conformity for details.



Notice for European Community: This product complies with the relevant European legal Directives: EMC Directive (2014/30/EU) and Low Voltage Directive (2014/35/EU).



The Regulatory Compliance Mark (RCM) mark is a registered trademark. This signifies compliance with the Australia EMC Framework regulations under the terms of the Radio Communication Act of 1992.

ICES/NMB-001

ICES/NMB-001 indicates that this ISM device complies with the Canadian ICES-001.



This symbol represents the time period during which no hazardous or toxic substance elements are expected to leak or deteriorate during normal use. Forty years is the expected useful life of this product.



MSIP-REM-Kst-
BL16191

South Korean Class A EMC Declaration. this equipment is Class A suitable for professional use and is for use in electromagnetic environments outside of the home.

A 급 기기 (업무용 방송통신기자재) 이 기기는 업무용 (A 급) 전자파적합 기기로서 판 매자 또는 사용자는 이 점을 주의하시기 바라 며 , 가정외의 지역에서 사용하는 것을 목적으로 합니다.



Waste Electrical and Electronic Equipment (WEEE) Directive 2002/96/EC

This product complies with the WEEE Directive (2002/96/EC) marking requirement. The affixed product label (see below) indicates that you must not discard this electrical/electronic product in domestic household waste.

Product Category: With reference to the equipment types in the WEEE directive Annex 1, this product is classified as a "Monitoring and Control Instrumentation" product.

Do not dispose in domestic household waste.

To return unwanted products, contact your local Keysight office for more information.



Contents

1 Getting Started

Unpacking	2
What You Need to Get Started	2
Key Features	3
Chassis Description	4
Additional Equipment	6
EMC Filler Panels	6
Slot Blockers	6
Rack Mount Kit	6
M9005A Chassis Backplane Overview	7
Interoperability with CompactPCI	7
Interface	8
Hybrid Peripheral Slots	8
PXI Express Peripheral Slots	8
PXI Local Bus	9
PXI Trigger Bus	9
System Reference Clock	10

2 Installation and Configuration

Safety Information	14
Chassis Cooling Considerations	14
Providing Adequate Clearance	15
Chassis Ambient Temperature Definition	16
Setting Fan Speed	16
Installing EMC Filler Panels	16
Installing Slot Blockers	16
Rack Mounting	16
Connecting Safety Ground	17
Connecting to Power Source	17
Getting Started With The System	17
Unpacking the Host Card	18
Hardware Installation	19
Installing an ExpressCard Module	19
Installing a PCI Express Host Card	20
Cabling	22
Powering Up the System	23
Powering Down the System	23
Checking LEDs for Status	23
Functional Overview	24
Installing Peripheral Modules	25

PXI Express System Configuration with Keysight Connection Expert	26
Basic PXI System Configuration	28
Trigger Configuration	29
Using System Configuration and Initialization Files	31

3 Maintenance

Service Interval	33
Preparation	33
Cleaning	33
Interior Cleaning	34
Exterior Cleaning	34

4 Troubleshooting

Chassis Not Recognized by Adapter Card	35
Chassis Will Not Turn On	36
Returning the Chassis	36

5 Specifications

M9005A Specifications	40
Electrical	40
AC Input	40
DC Output	40
Chassis Cooling	41
Module cooling	41
Power supply cooling	41
Environmental	42
Operating Environment	42
Storage Environment	42
Shock and Vibration	42
Random Vibration	42
Acoustic Emissions	43
Sound Pressure Level (at Operator Position)	43
Sound Power	43
Backplane	43
System Synchronization Clocks (PXI_CLK10, PXIe_CLK100, PXIe_SYNC100)	44
10 MHz System Reference Clock: PXI_CLK10	44
100 MHz System Reference Clock: PXIe_CLK100 and PXIe_SYNC100	44
Mechanical	45
Overall dimensions (standard chassis)	45
Adapter Card Specifications	49
Physical	49
Power Requirements	49
Environmental	49
Operating Environment	50
Storage Environment	50

6 Pinouts

Hybrid Slot Pinouts. 51

Index

1 Getting Started

This chapter describes the key features of the M9005A chassis, and lists the kit contents and optional equipment you can order from Keysight.

Unpacking

Carefully inspect the shipping container and the chassis for damage. Check for visible damage to the metal work. Check to make sure all handles, hardware, and switches are undamaged. Inspect the inner chassis for any possible damage, debris, or detached components. If damage appears to have been caused during shipment, file a claim with the carrier. Retain the packing material for possible inspection and/or reshipment.

What You Need to Get Started

The M9005A chassis kit contains the following items:

- M9005A PXIe Chassis User Guide
- Four filler panels. Additional filler panels (part number Y1213A) are available.
- AC power cable
- M9005 PXIe Chassis Product Software and Information CD (part number M9005-10001)
- KT-for Your Safety Guide (included on M9005 PXIe Chassis Product Software and Information CD)
- Chassis number labels
- x1 cable
- x1 adapter card

Key Features

The M9005A chassis combines a 5-slot PXI backplane with a structural design that has been optimized for maximum usability in a wide range of applications.

The key features of the chassis include the following:

- Accepts 3U PXI Express, CompactPCI Express, and hybrid slot compatible PXI-1/CompactPCI (PICMG EXP.0 R1.0) modules
- 5 peripheral slots in a rugged, compact chassis with universal AC input, and automatic voltage/frequency ranging
- Integrated controller
- On/Standby momentary power switch on the front panel for easy access
- AUTO/HIGH temperature-controlled fan speed based on air-intake temperature to minimize audible noise
- Rack mountable

CAUTION

There are no rail guides or backplane connections in slot 1 to accommodate a controller or interface module. Do *not* try to install an embedded controller or interface module into the M9005A chassis.

The controller for the M9005A is built into the chassis and is accessed through the controller connector located on the rear of the chassis. Refer to [Figure 2](#) on page 5 for the controller connector location.

Chassis Description

Figure 1 and Figure 2 show the key features of the M9005A chassis front and rear panels. Figure 1 shows the front view of the M9005A. Figure 2 shows the rear view of the M9005A. Figure 3 shows the bottom of the chassis.

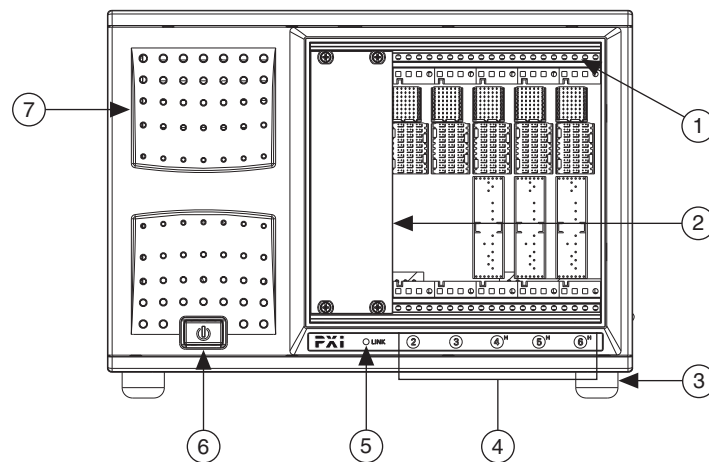

-
- | | |
|----------------------------|-------------------------------------|
| 1 Captive Screw | 5 Link LED |
| 2 PXI Filler Panel | 6 Power Switch |
| 3 Rubber Foot | 7 Power Supply Airflow Intake Vents |
| 4 Generic Peripheral Slots | |
-

Figure 1 Front View of the M9005A Chassis

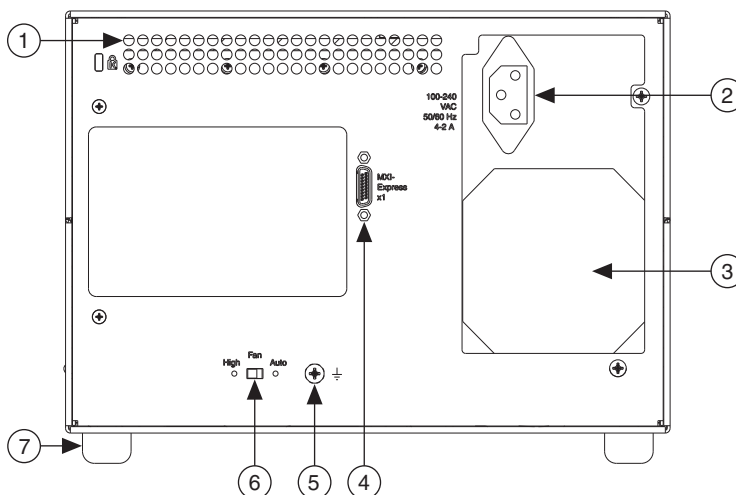

- | | |
|--------------------------------|---------------------------------------|
| 1 Rear Exhaust Vents | 5 Chassis Ground Screw |
| 2 AC Input | 6 Auto/High Fan Speed Selector Switch |
| 3 Power Supply Fan Exhaust | 7 Rubber Foot |
| 4 Chassis Controller Connector | |

Figure 2 Rear View of the M9005A Chassis

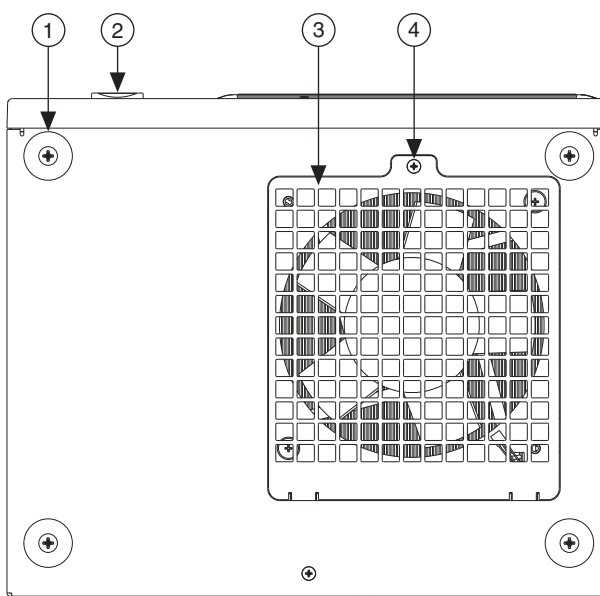

- | | |
|----------------|--------------------------|
| 1 Rubber Foot | 3 Fan Intake Cover |
| 2 Power Switch | 4 Fan Intake Cover Screw |

Figure 3 Bottom View of the M9005A Chassis

Additional Equipment

Contact Keysight to order the following options for the M9005A chassis.

EMC Filler Panels

EMC filler panel kits (part number Y1213A) are available from Keysight.

Slot Blockers

Slot blocker kits (part number Y1212A) are available from Keysight for improved thermal performance when all slots are not used.

Rack Mount Kit

A rack mount kit (part number Y1274A) is available for mounting the M9005A chassis into a 19 in. instrument cabinet. Refer to [Figure 19](#) on page 48 for more information.

M9005A Chassis Backplane Overview

Interoperability with CompactPCI

The design of the M9005A chassis provides you the flexibility to use the following devices in a single PXI Express chassis:

- PXI Express compatible products
- CompactPCI Express compatible Type-2 peripheral products
- PXI hybrid slot compatible peripheral products
- Standard CompactPCI peripheral products

Refer to [Figure 4](#) for an overview of the M9005A architecture.

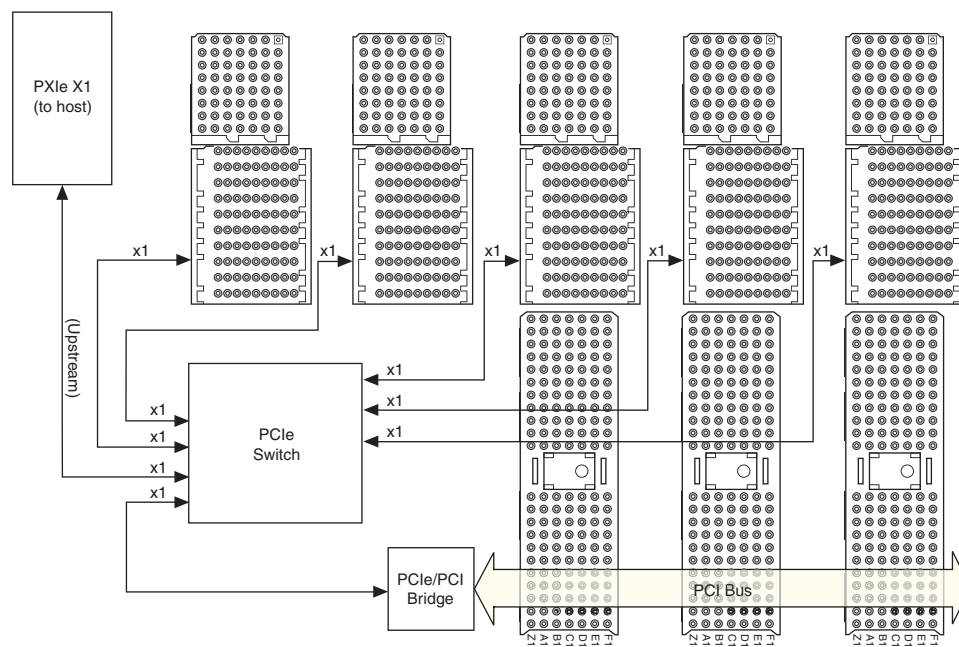

Figure 4 M9005A Backplane Architecture

The chassis backplane has +5 V V(I/O). Refer to the **CompactPCI PICMG 2.0 R 3.0 Specification** for details regarding V(I/O).

Interface

The M9005A chassis has a built-in x1 interface that can be accessed through the chassis controller connector on the back of the chassis, as shown in [Figure 2](#).

The interface can be cabled to a remote system with a host card using a x1 cable to provide control of the M9005A chassis. Keysight offers two options:

- M9005A-001—PCIe Express Card Adapter for M9005A with 3 m cable.
- M9005A-002—PCIe Desktop Adapter for M9005A with 3 m cable.

NOTE

The M9005A chassis does not have a slot number 1 because it is replaced by the rear connector.

Hybrid Peripheral Slots

The chassis provides three (3) hybrid peripheral slots (slot numbers 4–6) as defined in the **PXI-5 PXI Express Hardware Specification**. These hybrid peripheral slots can accept the following peripheral modules:

- A PXI Express Peripheral with a x1 PCI Express link through the PCI Express switch to the upstream PC.
- A CompactPCI Express Type-2 Peripheral with a x1 PCI Express link through a PCI Express switch to the upstream PC.
- A hybrid-compatible PXI Peripheral module that has been modified by replacing the J2 connector with an XJ4 connector installed in the upper eight rows of J2. Refer to the **PXI Express Specification** for details. The PXI Peripheral communicates through the backplane's 32-bit PCI bus.
- A CompactPCI 32-bit peripheral on the backplane's 32-bit PCI bus.

The hybrid peripheral slots provide full PXI Express functionality and 32-bit PXI functionality except for PXI Local Bus. The hybrid peripheral slot only connects to PXI Local Bus 6 left and right.

PXI Express Peripheral Slots

There are two (2) PXI Express peripheral slots: slots 2 and 3. PXI Express peripheral slots can accept the following modules:

- A PXI Express Peripheral with a x1 PCI Express link through the PCI Express switch to the upstream PC.
- A CompactPCI Express Type-2 Peripheral with a x1 PCI Express link through a PCI Express switch to the upstream PC.

PXI Local Bus

The PXI backplane local bus is a daisy-chained bus that connects each peripheral slot with the adjacent peripheral slots to the left and right (refer to [Figure 5](#)).

The backplane routes PXI Local Bus 6 between adjacent PXI slots. The left local bus 6 from slot 2 is not routed anywhere and the right local bus signal from slot 6 is not routed anywhere.

Local bus signals may range from high-speed TTL signals to analog signals as high as 42 V.

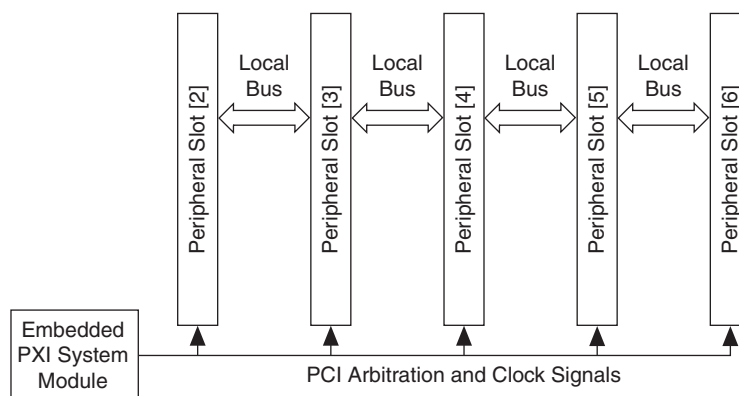

Figure 5 Local Bus Routing

PXI Trigger Bus

All slots share eight PXI trigger lines. You can use these trigger lines in a variety of ways. For example, you can use triggers to synchronize the operation of several different PXI peripheral modules. Modules can pass triggers to one another, allowing precisely timed responses to asynchronous external events the system is monitoring or controlling.

The PXI trigger lines allow you to send trigger signals to, and receive trigger signals from, every slot in the chassis. Static trigger routing (user-specified line assignments) can be configured through Keysight Connection Expert. Dynamic routing of triggers (automatic line assignments) is supported through certain Keysight drivers.

System Reference Clock

The M9005A provides a 10 MHz clock (PXI_CLK10) and 100 MHz clock (PXIe_CLK100) to each peripheral slot. The 100 MHz clock is a high speed LVPECL clock, while the 10 MHz clock is a TTL/CMOS clock. The backplane also provides a PXIe_SYNC100 signal which asserts a 10 ns pulse which is synchronous to PXIe_CLK100.

An independent buffer (having a source impedance matched to the backplane and a skew of less than 250 ps between slots) drives PXI_CLK10 to each peripheral slot. You can use this common reference clock signal to synchronize multiple modules in a measurement or control system.

An independent buffer drives PXIe_CLK100 to each peripheral slot. These clocks are matched in skew to less than 100 ps. The differential pair must be terminated on the peripheral with LVPECL termination for the buffer to drive PXIe_CLK100 so that when there is no peripheral or a peripheral that does not connect to PXIe_CLK100, there is no clock being driven on the pair to that slot. Refer to [Figure 6](#) for a termination example.

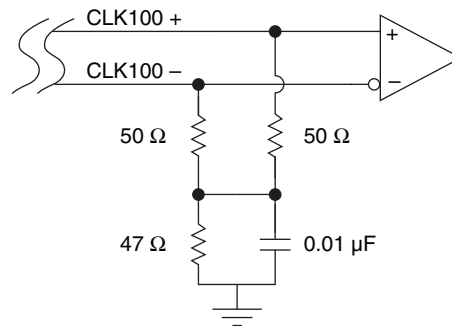

Figure 6 CLK100 Termination

An independent buffer drives PXIe_SYNC100 to each peripheral slot. The differential pair must be terminated on the peripheral with LVPECL termination for the buffer to drive PXIe_SYNC100 so that when there is no peripheral or a peripheral that does not connect to PXIe_SYNC100, there is no SYNC100 signal being driven on the pair to that slot. Refer to [Figure 6](#) for a termination example.

PXI_CLK10, PXIE_CLK100, and PXIE_SYNC100 are driven to every peripheral slot and have the default timing relationship described in [Figure 7](#).

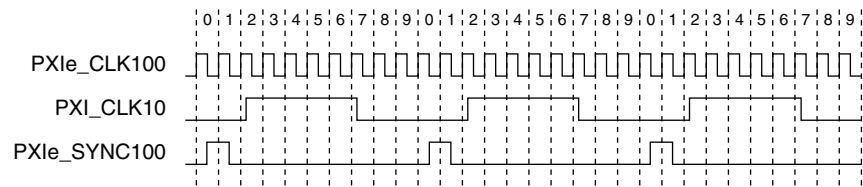

Figure 7 System Reference Clock Default Behavior

2 Installation and Configuration

This chapter describes how to install, configure, and use the M9005A chassis.

NOTE

There is no IVI driver included with this chassis. Also, there is no Soft Front Panel. The software provided on the M9005A PXIe Chassis Software and Product Information CD allows the PXI Resource manager to enumerate both the M9005A chassis and installed peripheral modules.

Before connecting the chassis to a power source, read this chapter and the **KT-for Your Safety Guide** included on M9005 PXIe Chassis Product Software and Information CD.

Safety Information

CAUTION

Before undertaking any troubleshooting, maintenance, or exploratory procedure, carefully read the following caution notices.

This equipment contains voltage hazardous to human life and safety, and is capable of inflicting personal injury.

- **Chassis Grounding**—The chassis requires a connection from the premise wire safety ground to the chassis ground. The earth safety ground must be connected during use of this equipment to minimize shock hazards. Refer to “**Connecting Safety Ground**” on page 17 for instructions on connecting safety ground.
- **Live Circuits**—Operating personnel and service personnel must not remove protective covers when operating or servicing the chassis. Adjustments and service to internal components must be undertaken by qualified service technicians. During service of this product, the mains connector to the premise wiring must be disconnected. Dangerous voltages may be present under certain conditions; use extreme caution.
- **Explosive Atmosphere**—Do not operate the chassis in conditions where flammable gases are present. Under such conditions, this equipment is unsafe and may ignite the gases or gas fumes.
- **Part Replacement**—Only service this equipment with parts that are exact replacements, both electrically and mechanically. Contact Keysight for replacement part information. Installation of parts with those that are not direct replacements may cause harm to personnel operating the chassis. Furthermore, damage or fire may occur if replacement parts are unsuitable.
- **Modification**—Do not modify any part of the chassis from its original condition. Unsuitable modifications may result in safety hazards.

Chassis Cooling Considerations

The M9005A chassis is designed to operate on a bench or in an instrument rack. Determine how you want to use the chassis and follow the appropriate installation instructions.

Providing Adequate Clearance

CAUTION

Failure to provide adequate clearances may result in thermal related failures in the chassis or modules.

Apertures in the top, bottom, front, rear, and along the right side of the chassis facilitate power supply and module cooling. Air enters through a fan intake in the bottom of the chassis for module cooling. It then exits through the upper sections at the right side, back, and through the top, as shown in [Figure 8](#). Air cooling the power supply enters the front of the chassis, which is shown in [Figure 1](#) on page 4, then exits through the rear of the chassis, which is shown in [Figure 2](#) on page 5. Place the chassis on a bench top or in an instrument rack so that the fans (air intakes) and the air outlet apertures along the right side, the top, and the back of the chassis have adequate ventilation. Provide at least 44.5 mm (1.75 in.) clearance above, behind, and on the sides of the unit for adequate venting. High-power applications may require additional clearance.

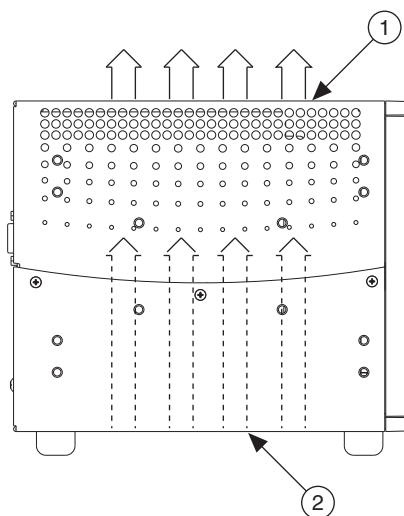

1 Air Outlets

2 Air Intake

Figure 8 M9005A Module Cooling Airflow Side View

CAUTION

Do not block air intake. This could lead to overheating.

Chassis Ambient Temperature Definition

The chassis fan control system uses intake air temperature as the input for controlling fan speeds when in Auto Fan Speed mode. Because of this, the chassis ambient temperature is defined as the temperature that exists just outside of the fan intake vent on the bottom of the chassis. Note that this temperature may be higher than ambient room temperature depending on the surrounding equipment and/or blockages present. It is the user's responsibility to ensure that this ambient temperature does not exceed the rated ambient temperature as stated in the "Specifications" on page 39.

CAUTION

Slot 6 will have higher temperature rise than other slots.

Setting Fan Speed

The AUTO/HIGH fan-speed selector switch is on the rear panel of the M9005A. Refer to [Figure 2](#) on page 5, to locate the fan-speed selector switch. Select HIGH for maximum cooling performance (recommended) or AUTO for quieter operation. When set to AUTO, the fan speed is determined by chassis intake air temperature.

NOTE

High power PXI modules should be installed in slot 2, 3, or 4 with the fan speed set to HIGH.

Installing EMC Filler Panels

To improve module cooling performance, install EMC filler panels (part number Y1213A) in unused or empty slots. Secure with the captive mounting screws provided.

Installing Slot Blockers

The cooling performance of the chassis can be improved by installing optional slot blockers (part number Y1212A).

Rack Mounting

Rack mount applications require the optional rack mount kits available from Keysight. Refer to [Figure 19](#) on page 48, and the instructions supplied with the rack mount kits to install your chassis in an instrument rack.

CAUTION

When rack-mounting, leave a 1 U air gap above and below the chassis.

NOTE

You may want to remove the feet from the chassis when rack mounting. To do so, remove the screws holding the feet in place.

Connecting Safety Ground

CAUTION

The M9005A chassis is designed with a three-position inlet that connects the cord set ground line to the chassis ground. To minimize shock hazard, make sure the electrical power outlet you use to power the chassis has an appropriate earth safety ground.

Connecting to Power Source

CAUTION

- Do *not* install modules prior to performing the following power-on test.
 - To completely remove power, you *must* disconnect the power cable.
-

Attach input power through the rear AC inlet using the appropriate AC power cable supplied. Refer to [Figure 2](#) on page 5, to locate the AC inlet.

The power switch allows you to power on the chassis or place it in standby mode. Press the power switch to turn on the chassis. Observe that the fan becomes operational.

Getting Started With The System

To set up and use your cards, you need the following:

- One host card (PCI Express or ExpressCard) and one M9005A chassis
- A x1 copper cable
- A host PC with an available x1 (or wider) PCI Express slot or a laptop with an available ExpressCard slot

Unpacking the Host Card

Your card is shipped in antistatic packages to prevent electrostatic damage (ESD) to the devices. ESD can damage several components on the device.

CAUTION

Never touch the exposed pins of connectors. Doing so may damage the device.

To avoid such damage in handling the device, take the following precautions:

- Ground yourself using a grounding strap or by holding a grounded object.
- Touch the antistatic package to a metal part of the computer chassis before removing the device from the package.

Remove the device from the package and inspect the device for loose components or any sign of damage. Notify Keysight if the device appears damaged in any way. Do not install a damaged device into the computer or PXI/CompactPCI chassis.

Store the device in the antistatic envelope when not in use.

Hardware Installation

The following are general instructions for installing the card. Consult your computer user manual or technical reference manual for specific instructions and warnings.

NOTE

The software for your kit is included with the M9005 PXIe Chassis Product Software and Information CD.

Installing an ExpressCard Module

Because a laptop is not grounded, follow this procedure to safely connect it to your PXI system:

- 1** Unpack the ExpressCard module as directed in the previous section.
- 2** Touch the ExpressCard module and a metal part of the PXI chassis simultaneously.
- 3** Connect the cable to the ExpressCard module and the M9005A chassis.
- 4** Plug the ExpressCard module into an available ExpressCard slot.

If your computer is already running (or hibernating) when you install ExpressCard module, you must reboot to detect the PXI system. Otherwise, the PXI system is detected when you start your computer.

Figure 9 shows how to insert the ExpressCard module and connect the cable.

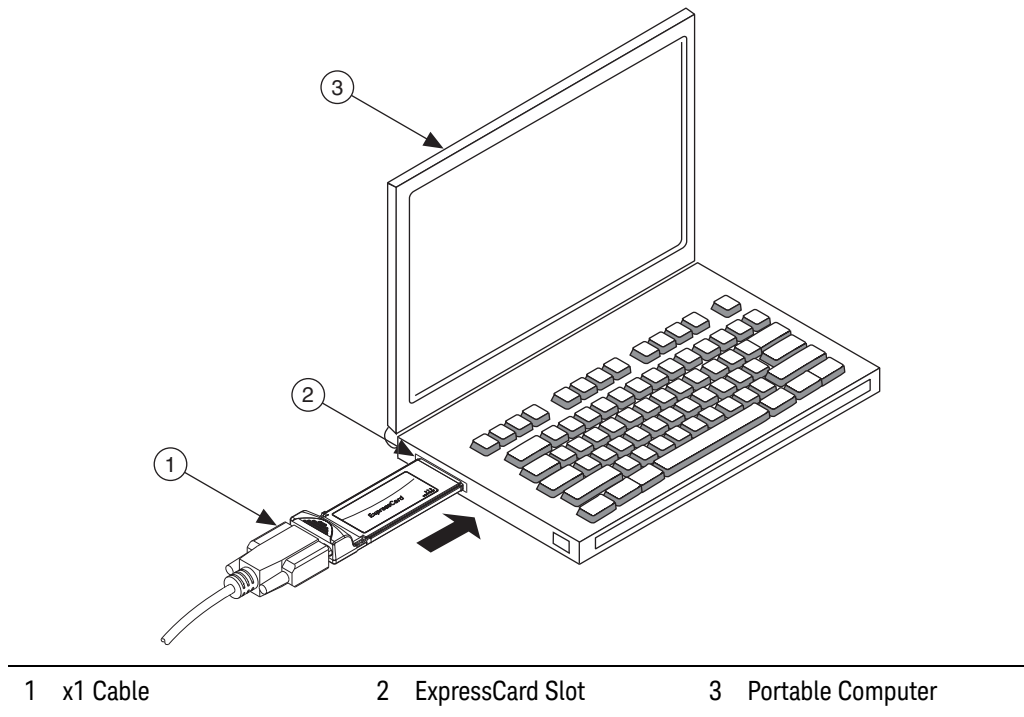

Figure 9 Installing the ExpressCard Module

Installing a PCI Express Host Card

The following steps detail the process of installing an PCI Express host card. Refer to [Figure 10](#) to assist you in completing this procedure.

- 1 Power off your computer, but leave it plugged in while installing the PCI Express host card. The power cord grounds the chassis and protects it from electrical damage while you install the card.

CAUTION

To protect both yourself and the computer from electrical hazards, your computer should remain off until you finish installing the PCI Express host card.

- 2 Remove the top cover or access port to the PCI Express bus.
- 3 Select any available PCI Express expansion slot (x1 or wider).

NOTE

The BIOS or motherboard may not support the PCI Express host card in a slot intended for a graphics card.

- 4 Locate the metal bracket that covers the cut-out in the back panel of the computer for the slot you have selected. Remove and save the bracket-retaining screw and the bracket cover.
- 5 Touch the metal part of the power supply case inside the computer to discharge any static electricity that might be on your clothes or body.
- 6 Line up the PCI Express host card with the slot on the back panel. Slowly push down on the top of the PCI Express host card until its card-edge connector is resting on the expansion slot receptacle. Using slow, evenly distributed pressure, press the PCI Express host card straight down until it seats in the expansion slot.
- 7 Reinstall the bracket-retaining screw to secure the PCI Express host card to the back panel rail.
- 8 Replace the computer cover.

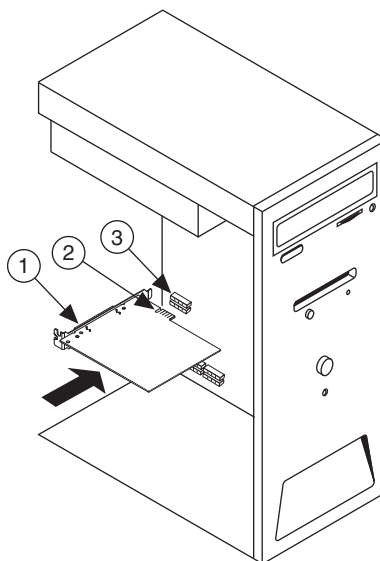

1 PCI Express Host Card

2 PCI Express x1 Card-Edge Connector

3 PCI Express Slot

Figure 10 Installing the PCI Express Host Card

Figure 11 shows the cable connection with which a PCI Express host card controls the M9005A chassis.

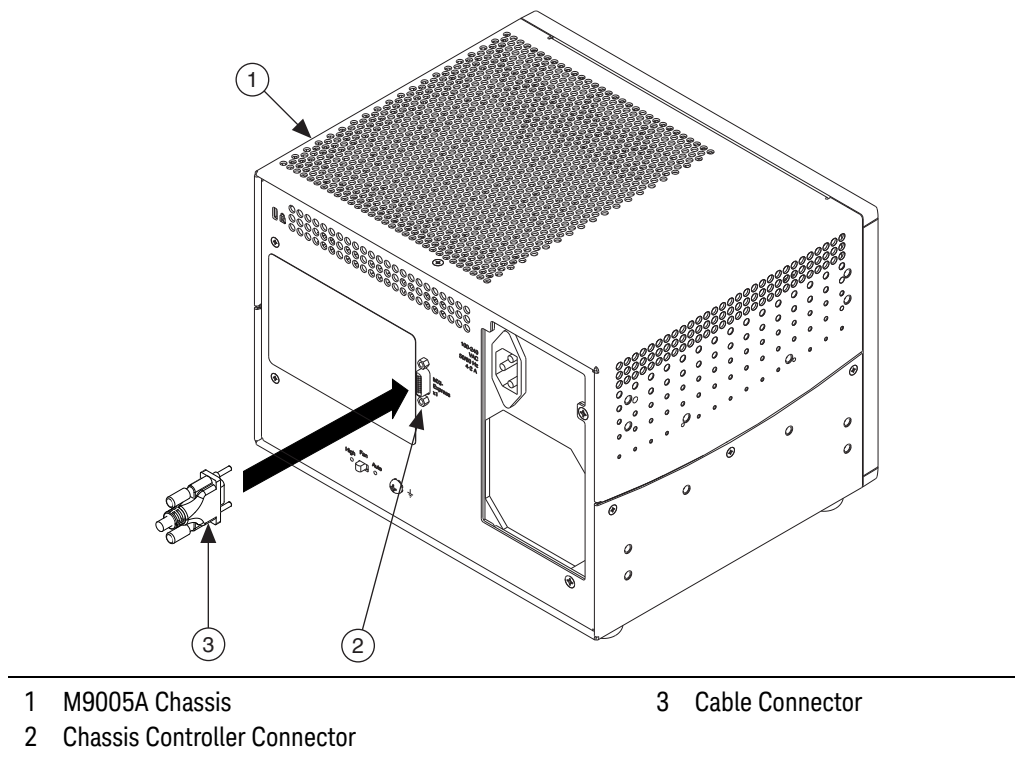

Figure 11 PCI Express Host Card Cable Connection

Cabling

Connect the appropriate cable to the PCI Express card and M9005A chassis. The cables have no polarity, so either end may be connected to either connector.

CAUTION

Do *not* remove the cable after the system is powered up. Doing so can hang or cause errors in applications communicating with devices.

If a cable becomes unplugged, do *not* plug it back into the system. Complete the following steps when a cable is unplugged:

- 1 Power down the PC.
- 2 Power down the chassis
- 3 Reconnect the cable.
- 4 Power up the chassis.
- 5 Power up the PC.

Powering Up the System

- 1 Power up the chassis.
- 2 Power up the host.

Typical PCI-PCI bridges are used to add PCI devices to a PCI hierarchy in which all the bridges and devices are contained within a single chassis. Because of this, BIOSes and operating systems make the assumption that all PCI devices in the entire hierarchy will be available as soon as code execution begins at power-up time. This assumption means that all of the expansion chassis must be turned on before the host PC for the BIOS and OS to correctly configure a system.

NOTE

The M9005A chassis will assert a wake signal on power up. The host PC also will power on if it supports this functionality.

Powering Down the System

Because operating systems and drivers commonly make the assumption that PCI Express/PCI devices will be present in the system from power-up to power-down, it is important not to power off the expansion chassis until after the host PC is powered off. Powering off the expansion chassis while the host is still on can cause crashes or hangs. As a result, the user must press and hold the power button for 3 seconds in order to power down a linked-up M9005A. The order in which expansion chassis are powered off, relative to each other, is not important.

NOTE

If the M9005A experiences a fan or power supply failure, the chassis will power down and remain in standby indefinitely until AC power has been cycled. This failure could cause the upstream system to crash or hang.

Checking LEDs for Status

After powering on the M9005A chassis you should check the LEDs for status to ensure that all connected systems have linked. The following table defines the LED states.

Table 1 LED Status for the M9005A Chassis

LED	Color	Meaning
PWR	Off	No power
	Green	Power is within spec
	Red	Fan failure
	Blinking Red	Power is out of spec
LINK	Off	Link not established
	Green	Link established

NOTE

- If the system fan fails the chassis will shut down automatically, preventing the chassis and modules from damage due to overheating. The chassis will not attempt another power on until AC power has been cycled.
- If the power supply has a failure, the chassis will prevent potential damage by shutting down automatically. The chassis will not attempt another power on until AC power has been cycled.

Functional Overview

PCI Express is a high-speed serial computer expansion bus. The ExpressCard standard specifies the PCIe slots built into a computer and the PCIe expansion cards to insert in the slots. ExpressCard is a laptop expansion card interface. Plugging the ExpressCard into a laptop provides point-to-point connectivity to the PCIe connector, in this case, built into the M9005A chassis. The PCI Express-to-PCI bridge architecture is transparent to device drivers, so no additional software is needed to support using PXI and CompactPCI devices in a connected chassis.

The link between the PC and the chassis is a x1 cabled PCI Express link. This link is a dual-simplex communication channel comprised of a low-voltage, differentially driven signal pair. The link can transmit at a rate of 2.5 Gbps in each direction simultaneously.

Installing Peripheral Modules

CAUTION

The M9005A chassis has been designed to accept a variety of peripheral module types in different slots. To prevent damage to the chassis, ensure that the peripheral module is being installed into a slot designed to accept it. Refer to “[M9005A Chassis Backplane Overview](#)” on page 7, for a description of the various slot types.

This section contains general installation instructions for installing a peripheral module in a M9005A chassis. Refer to your peripheral module user manual for specific instructions and warnings. To install a module, complete the following steps:

CAUTION

Do not insert a hybrid PXI module (with J1 and XJ4 connectors) into slot 2 or 3, or pin damage may occur.

- 1 Inspect the slot for any physical damage or bent pins before installing the peripheral module.
- 2 Connect the AC power source to the PXI Express chassis before installing the module. The AC power cord grounds the chassis and protects it from electrical damage while you install the module.
- 3 Ensure that the chassis is powered off.
- 4 Install a module into a chassis slot by first placing the module card PCB into the front of the card guides (top and bottom), as shown in [Figure 12](#). Slide the module to the rear of the chassis, making sure that the injector/ejector handle is pushed down as shown in [Figure 12](#).
- 5 When you begin to feel resistance, push up on the injector/ejector handle to fully seat the module into the chassis frame. Secure the module front panel to the chassis using the module front-panel mounting screws.

NOTE

You must install your module driver software provided by the module manufacturer before using the modules in the chassis.

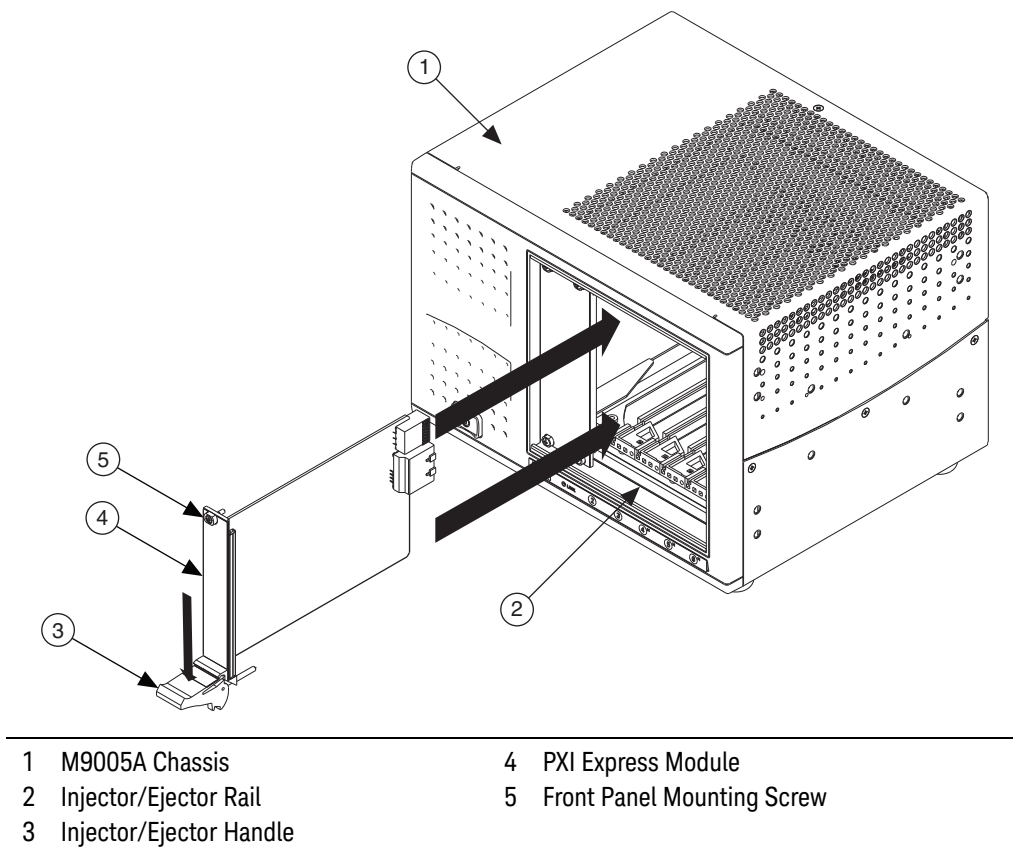

Figure 12 Installing PXI or CompactPCI Modules

PXI Express System Configuration with Keysight Connection Expert

Chassis driver software provided with the M9005 allows the system PXI Resource manager to enumerate the M9005 chassis and its installed peripheral modules. You can configure both PXIe and PXI-1 chassis through Keysight IO Libraries (version 17.2 or later), which is available through www.keysight.com/find/iosuite. Keysight IO Libraries contains a PXI Resource Manager that will enumerate the PXI system and generate the **pxiesys.ini** and **pxisys.ini** files, which define your PXI system parameters. Keysight IO Libraries also provides an interface to reserve PXI trigger lines so that dynamic routing done by some PXI instrument drivers will not double-drive a trigger line (potentially damaging trigger hardware). For more information about routing and reserving PXI triggers, refer to the **Chassis Trigger** section of **IO Libraries Suite Help**.

The configuration steps for single or multiple-chassis systems are the same.

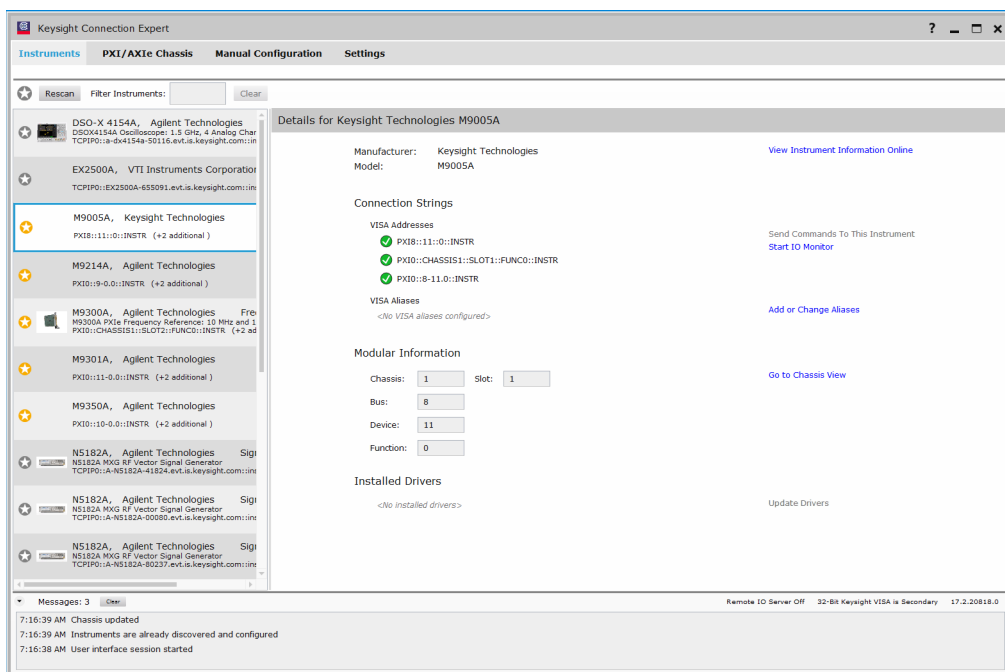

Figure 13 Instruments View in Keysight Connection Expert

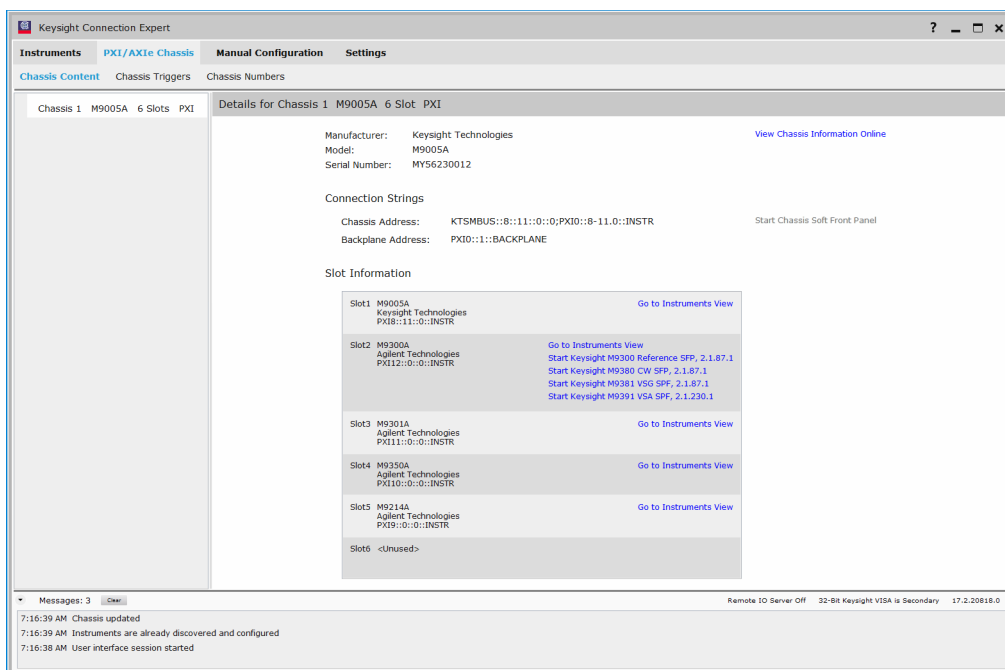

Figure 14 PXI/AXIe Chassis View in Keysight Connection Expert

Basic PXI System Configuration

The M9005A chassis driver software provided on the **M9005 PXIe Chassis Product Software and Information CD** will automatically detect your M9005A chassis. To manually configure your chassis follow the steps outlined below. Refer to [Figure 14](#) while completing the following steps:

- 1 Install **IO Libraries** version 17.2 or later.
- 2 Power down the computer.
- 3 Ensure the PXIe/PXI/PCI modules are installed correctly in the chassis.
- 4 Connect the chassis to the computer via PCIe ExpressCard adapter and cable.
- 5 Power up the chassis and then the computer.
- 6 Run **Keysight Technologies Connection Expert**.
- 7 Instrument Discovery Service will auto-discover many instruments that are physically connected to your PC or are on your local LAN subnet. Auto-discovered instruments are shown in the **Instruments** view automatically; either when discovered or when you click **Rescan**. [Figure 13](#) shows the **Instruments** view.
Once Connection Expert identifies your chassis, and all modules in it, the required **pxisys.ini** and **pxiesys.ini** files are created.
- 8 Click on the **PXI/AXIe** tab as shown in [Figure 14](#). In the **Chassis Content** view, you will see a list of all the chassis that have been discovered or manually added. In the **Chassis/Module Detail** view, you will see manufacturer, model number, serial number, addresses, etc. Access to soft front panels is available if applicable. The **Chassis Triggers** selection allows you to reserve trigger lines and create trigger routes. The **Chassis Numbers** selection allows you to change the numbering of the chassis to better correspond to your system's physical layout or to match the numbering used by an existing test program.
- 9 Apply the chassis number labels (shown in [Figure 15](#)) included with your kit to each chassis in your PXI system, and write in the chassis number accordingly in the white space.



Figure 15 Chassis Number Label

The PXI specification allows for many combinations of PXI chassis and system modules. To assist system integrators, the manufacturers of PXI chassis and system modules must document the capabilities of their products. PXI Express devices must provide a driver and **.ini** file for identification. The minimum documentation requirements for PXI-1 are contained in **.ini** files, which consist of ASCII text. System integrators, configuration utilities, and device drivers can use these **.ini** files.

The capability documentation for a PXI-1 chassis is contained in a **chassis.ini** file provided by the chassis manufacturer. The information in this file is combined with information about the system controller to create a single PXI-1 system initialization file called **pxisys.ini** (PXI System Initialization). The system controller uses Keysight IO Libraries to generate the **pxisys.ini** file from the **chassis.ini** file.

Device drivers and other utility software read the **pxiesys.ini** and **pxisys.ini** file to obtain system information. For detailed information about initialization files, refer to the PXI specification at www.pxisa.org.

Trigger Configuration

Each chassis has one or more trigger buses, each with eight lines numbered 0 through 7 that can be reserved and routed statically or dynamically. Static reservation pre-allocates a trigger line to prevent its configuration by a user program. Dynamic reservation/routing/deallocation is performed on the fly within a user program based upon Keysight APIs. Static reservation of trigger lines can be implemented by Keysight Connection Expert through the **PXI/AXIe Chassis > Triggers** tab. Reserved trigger lines will not be used by PXI modules dynamically configured by programs. This prevents the instruments from double-driving the trigger lines, possibly damaging devices in the chassis. For example, if trigger line 3 is asserted, by default it will not be automatically asserted by any other module.

Complete the following steps to reserve these trigger lines in Keysight Connection Expert.

- 1 In the **Chassis Content** view, click the PXI chassis you want to configure.
- 2 Select the **PXIe/AXIe Chassis > Chassis Triggers** tab.
- 3 Select which trigger lines you want to statically reserve. **Figure 16** shows Trigger 3 reserved.
- 4 Click the **Accept** button.

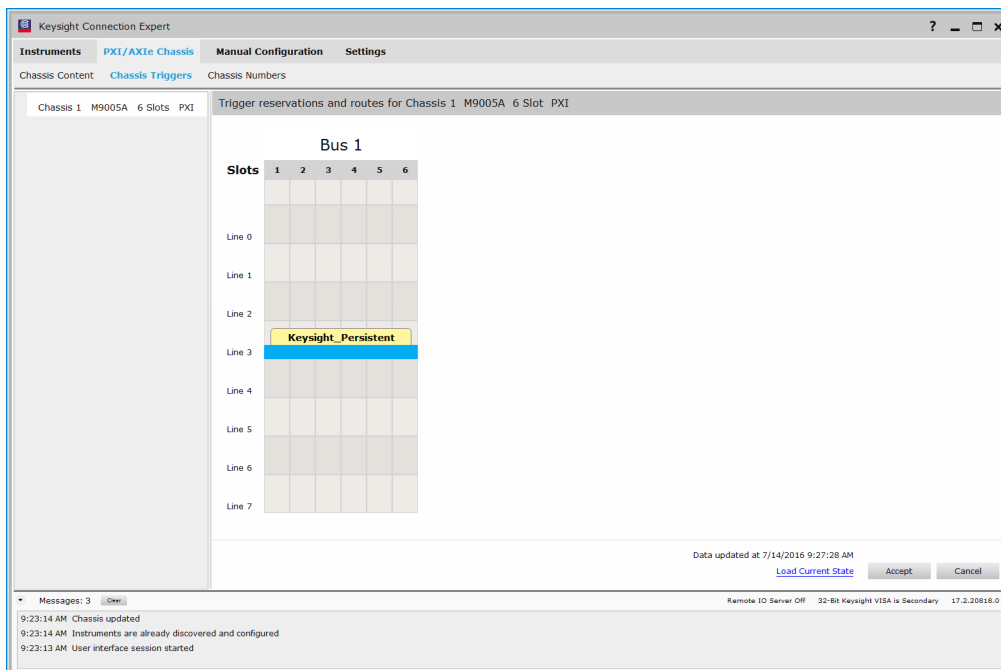

Figure 16 Reserving a Trigger Line in Keysight Connection Expert

Using System Configuration and Initialization Files

The PXI Express specification allows many combinations of PXI Express chassis and system modules. To assist system integrators, the manufacturers of PXI Express chassis and system modules must document the capabilities of their products. The minimum documentation requirements are contained in **.ini** files, which consist of ASCII text. System integrators, configuration utilities, and device drivers can use these **.ini** files.

The capability documentation for the M9005A chassis is contained in the **chassis.ini** file on the software media that comes with the chassis. The information in this file is combined with information about the system controller to create a single system initialization file called **pxisys.ini** (PXI System Initialization). The system controller manufacturer either provides a **pxisys.ini** file for the particular chassis model that contains the system controller or provides a utility that can read an arbitrary **chassis.ini** file and generate the corresponding **pxisys.ini** file. The Keysight IO Libraries provide the Resource Manager which is responsible for creating the **pxisys.ini** system description file according to the PXI specification.

Device drivers and other utility software read the **pxisys.ini** file to obtain system information. The device drivers should have no need to directly read the **chassis.ini** file. For detailed information regarding initialization files, refer to the PXI Express specification at www.pxisa.org.

3 Maintenance

This chapter describes basic maintenance procedures you can perform on the M9005A chassis.

CAUTION

Disconnect the power cables prior to servicing the chassis.

Service Interval

Clean dust from the chassis exterior (and interior) as needed, based on the operating environment. Periodic cleaning increases reliability and cooling performance.

Preparation

The information in this chapter is designed for use by qualified service personnel. Read the **KT-for Your Safety Guide** document included on M9005 PXIe Chassis Product Software and Information CD before attempting any procedures in this chapter.

CAUTION

Many components within the chassis are susceptible to static discharge damage. Service the chassis only in a static-free environment. Observe standard handling precautions for static-sensitive devices while servicing the chassis. Always wear a grounded wrist strap or equivalent while servicing the chassis.

Cleaning

CAUTION

Always disconnect the AC power cable before cleaning or servicing the chassis.

Cleaning procedures consist of exterior and interior cleaning of the chassis. Refer to your module user documentation for information on cleaning individual CompactPCI or PXI modules.

Interior Cleaning

Use a dry, low-velocity stream of air to clean the interior of the chassis. Use a soft-bristle brush for cleaning around components.

Exterior Cleaning

CAUTION

- Avoid getting moisture inside the chassis during exterior cleaning, especially through the top vents. Use just enough moisture to dampen the cloth.
 - Do not wash the front- or rear-panel connectors or switches. Cover these components while cleaning the chassis.
 - Do not use harsh chemical cleaning agents; they may damage the chassis. Avoid chemicals that contain benzene, toluene, xylene, acetone, or similar solvents.
-

Clean the exterior surfaces of the chassis with a dry lint-free cloth or a soft-bristle brush. If any dirt remains, wipe with a cloth moistened in a mild soap solution. Remove any soap residue by wiping with a cloth moistened with clear water. Do not use abrasive compounds on any part of the chassis.

4 Troubleshooting

The points of possible failures are the drivers, the PCIe MXI or ExpressCard, the PCIe cable, the chassis, the modules inside the chassis, or the host computer in general.

Chassis Not Recognized by Adapter Card

Performing the following steps can assist in narrowing down what's causing the issue. This troubleshooting process assumes the chassis powers on fine and can communicate with the adapter card via Keysight Connection Expert (part of the Keysight IO Libraries Suite).

- 1 Remove all modules from the chassis before troubleshooting.
- 2 Ensure that the chassis is turned on before the computer.
- 3 Make sure the PCIe is oriented correctly. The x1 cables can be rotated 180 degrees and inserted with a little force. This has happened many times.
- 4 If in a desktop, try all PCIe slots.
- 5 Check the host PC's device manager, are there any errors? Is anything missing? If there are, check if they are driver related. Double click on the device that has a **yellow exclamation mark (!)** beside it and look at the status. Try reinstalling the drivers or looking at Microsoft KBs for more help on general Device Manager and driver troubleshooting.
- 6 If no PCIe slots work, try a different desktop PC. If using a laptop, try a different laptop. Does it work in the other computer? If so, reexamine steps 1 through 4. If the system works on a different computer, it's the computer having an issue and not the chassis or PCIe card.

- 7 If the PCIe card or ExpressCard doesn't show up, ensure the drivers are installed and check device manager as in step 6. Has the card ever worked? For the PCIe case, do other PCIe cards work in the same slot? Does it work in different slots? If it works in some slots or some computers the card is good. If it doesn't work in any slots or computers and other cards work in them, the card is bad and should be replaced.
- 8 If the PCIe card is showing up but not the chassis, check the link light. If it shows no link, double check the orientation and try different PCIe cables. This scenario means the PCIe card is likely working, as it's showing up, but the link isn't being established, which points towards a issue or (less likely) an issue with the integrated MXI on the chassis. If it ends up being the chassis, return the chassis to Keysight. Note that it should only be returned after being tested on multiple systems, preferably with multiple PCIe cables and even PCIe/ExpressCards.

Chassis Will Not Turn On

- 1 Remove all modules from the chassis.
- 2 Check the PWR LED. Refer to [Table 1](#) on page 24.
- 3 If it's a fan failure, as indicated by the LED mentioned in Step 2, power cycle the chassis or try a different outlet. If the problem persists, return the chassis to Keysight.
- 4 If it's a power failure, try different outlets and cables. If different outlets and cables won't allow it to boot and the LED shows a power failure, return the chassis to Keysight.

Returning the Chassis

Complete the following steps to return the chassis:

- 1 If your chassis is being returned for service, review your chassis warranty information. This can be found online by going to: www.keysight.com/find/warranty and entering your product number **M9005A** and your serial number. The serial number is affixed to the rear of the chassis.
- 2 Contact Keysight to obtain a Return Material Authorization (RMA) and shipping address. For Keysight contact information, go to www.keysight.com/find/assist (worldwide contact information for repair and service) or refer to the **Support** information on the product web page at www.keysight.com/find/pxi-chassis. When you contact Keysight, you will typically be assigned a case ID number—please be sure to retain this number.

- 3** Write the following information on a tag and attach it to the chassis:
 - Name and address of owner. A P.O. box is not an acceptable address.
 - Product model number (for example, **M9005A**)
 - Product serial number (for example, **TWnnnnnnnn**). The serial number label is located on the back of the chassis. **IMPORTANT:** Keep a copy of the serial number for your records.
- 4** Remove and retain all modules and slot covers from the chassis, including the slot 1 module.
- 5** Carefully pack the chassis in its original packaging. If the original packaging is not available, use bubble wrap or packing peanuts, and place the chassis in a sturdy, sealed container and mark the container **“FRAGILE”**.
- 6** On the shipping label, write **ATTENTION REPAIR DEPARTMENT** and the RMA number provided by Keysight in step 2.

NOTE

Keep a copy of the chassis serial number, your Keysight-assigned case ID number, and the RMA number for your records. Provide these numbers in any future communications along with the chassis model number (M9005A).

5 Specifications

This chapter contains specifications for the M9005A chassis.

CAUTION

If the M9005A chassis is used in a manner inconsistent with the instructions or specifications listed by Keysight, the protective features of the chassis may be impaired.

NOTE

Specifications are subject to change without notice.

M9005A Specifications

Electrical

AC Input

- Input voltage range
100 to 240 VAC
- Operating voltage range
90 to 264 VAC
- Input frequency
50/60 Hz
- Operating frequency range
47 to 63 Hz
- Input current rating
4 to 2 A
- Efficiency
70% at full load, normal input voltage
- Power disconnect

The AC power cable provides main power disconnect. The front-panel power switch controls the internal chassis power supply that provides DC power to the CompactPCI/PXI backplane.

DC Output

Table 2 DC current capacity (I_{MP})

Voltage	Maximum Current
+3.3 V	15 A
+5 V	7.5 A
+5 V _{AUX}	1.0 A
+12 V	15 A
-12 V	0.75 A

NOTE

The maximum total power is 150 W. This represents 30 W per slot for each of the five slots of the chassis.

- Over-current protection
All outputs protected from short circuit

Table 3 Over-voltage protection

Over-voltage at	Active Range	
	Minimum	Maximum
+3.3 V	3.76 V	4.3 V
+5 V	5.74 V	7.0 V
+12 V	13.4 V	15.6 V

Chassis Cooling

- Per slot cooling capacity
38.25 W
- Slot airflow direction
Bottom of module to top of module

Module cooling

- System
Forced air circulation (positive pressurization) through a 126 CFM fan with High/Auto speed selector
- Intake
Bottom of chassis
- Exhaust
Along rear, right side, and top of chassis

Power supply cooling

- System
Forced air circulation through integrated fan
- Intake
Front side of chassis

- Exhaust
Rear side of chassis

Environmental

- Maximum altitude
2,000 m (800 mbar) (at 25 °C ambient)
- Measurement Category
II
- Pollution Degree
2
- For indoor use only.

Operating Environment

- Ambient temperature range
0 to 50 °C (Tested in accordance with IEC-60068-2-1 and IEC-60068-2-2.
Meets MIL-PRF-28800F Class 3 low temperature limit and high temperature limit.)
- Relative humidity range
20 to 80%, noncondensing (Tested in accordance with IEC-60068-2-56.)

Storage Environment

- Ambient temperature range
–20 to 70 °C (Tested in accordance with IEC-60068-2-1 and IEC-60068-2-2.
Meets MIL-PRF-28800F Class 3 limits.)
- Relative humidity range
10 to 95%, noncondensing (Tested in accordance with IEC-60068-2-56.)

Shock and Vibration

- Operational shock
30 g peak, half-sine, 11 ms pulse (Tested in accordance with IEC-60068-2-27. Meets MIL-PRF-28800F Class 2 limits.)

Random Vibration

- Operating
5 to 500 Hz, 0.3 g_{rms}

- Nonoperating
5 to 500 Hz, 2.4 g_{rms}
(Tested in accordance with IEC-60068-2-64. Nonoperating test profile exceeds the requirements of MIL-PRF-28800F, Class 3.)

Acoustic Emissions

Sound Pressure Level (at Operator Position)

Tested in accordance with ISO 7779. Meets MIL-PRF-28800F requirements.

- Auto fan (at 25 °C ambient)
43.3 dBA
- High fan
58.3 dBA

Sound Power

Tested in accordance with ISO 7779.

- Auto fan (at 25 °C ambient)
51.3 dBA
- High fan
64.6 dBA

Backplane

- Size
3U-sized; integrated controller and 5 peripheral slots. Compliant with IEEE 1101.10 mechanical packaging. PXI Express Specification compliant. Accepts both PXI Express and CompactPCI (PICMG 2.0 R3.0) 3U modules.
- V(I/O)¹
+5 V
- Backplane bare-board material
UL 94 V-0 recognized
- Backplane connectors
Conform to IEC 917 and IEC 1076-4-101, and are UL 94 V-0 rated

¹ V(I/O) is connected to the +5 V DC power plane, so the same specifications apply to V(I/O) and +5 V.

System Synchronization Clocks (PXI_CLK10, PXIe_CLK100, PXIe_SYNC100)

10 MHz System Reference Clock: PXI_CLK10

- Maximum slot-to-slot skew
250 ps
- Accuracy
 ± 25 ppm max. (guaranteed over the operating temperature range)

NOTE

The 10 MHz system reference clock does not require calibration.

- Maximum jitter
5 ps RMS phase-jitter (10 Hz–1 MHz range)
- Duty-factor
45%–55%
- Unloaded signal swing
3.3 V \pm 0.3 V

NOTE

For other specifications refer to the PXI-1 Hardware Specification.

100 MHz System Reference Clock: PXIe_CLK100 and PXIe_SYNC100

- Maximum slot-to-slot skew
100 ps
- Accuracy
 ± 25 ppm max. (guaranteed over the operating temperature range)
- Maximum jitter
3 ps RMS phase-jitter (10 Hz–12 kHz range) 2 ps RMS phase-jitter (12 kHz–20 MHz range)
- Duty-factor for PXIe_CLK100
45%–55%

- Absolute single-ended voltage swing (When each line in the differential pair has 50 Ω termination to 1.30 V or Thévenin equivalent)
400 to 1000 mV

NOTE

For other specifications refer to the PXI-5 PXI Express Hardware Specification.

Mechanical

Overall dimensions (standard chassis)

- Height
177 mm (6.97 in.)

NOTE

12.7 mm (0.50 in.) is added to height when feet are installed.

- Width
257.1 mm (10.12 in.)
- Depth
212.8 mm (8.38 in.)
- Weight
5 kg (11.0 lbs)
- Chassis materials
Sheet Aluminum, Extruded Aluminum, Cold Rolled Steel, Nylon
- Finish
Clear Chromate Conversion Coat on Aluminum
Electrodeposited Nickel Plate on Cold Rolled Steel
Polyester Urethane Powder Paint

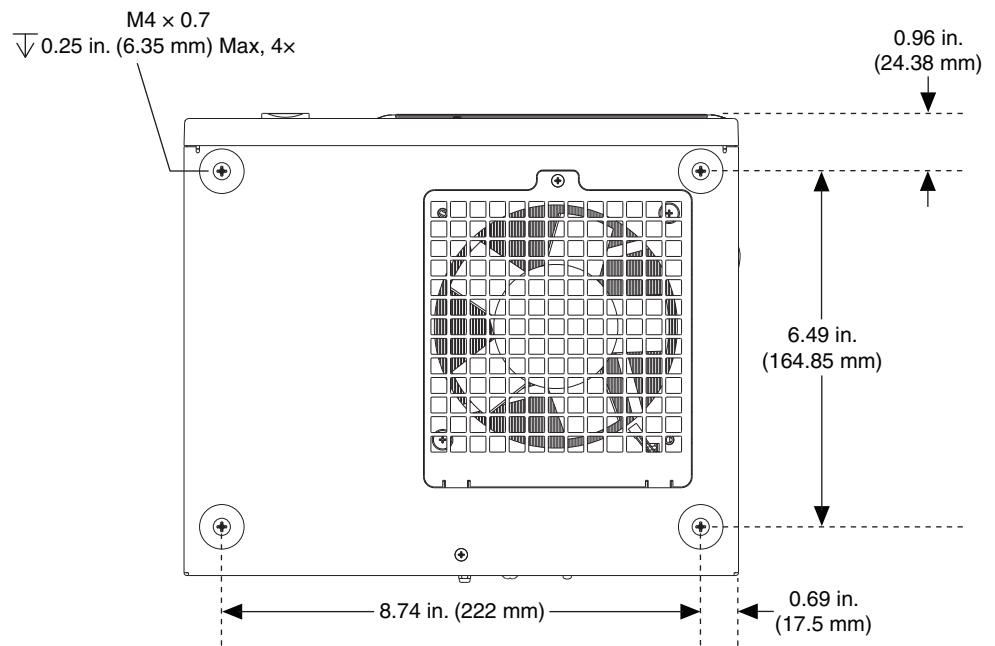

Figure 18 M9005A Chassis Dimensions (Bottom)

Figure 19 shows the Y1274A rack mount kit for the M9005A chassis.

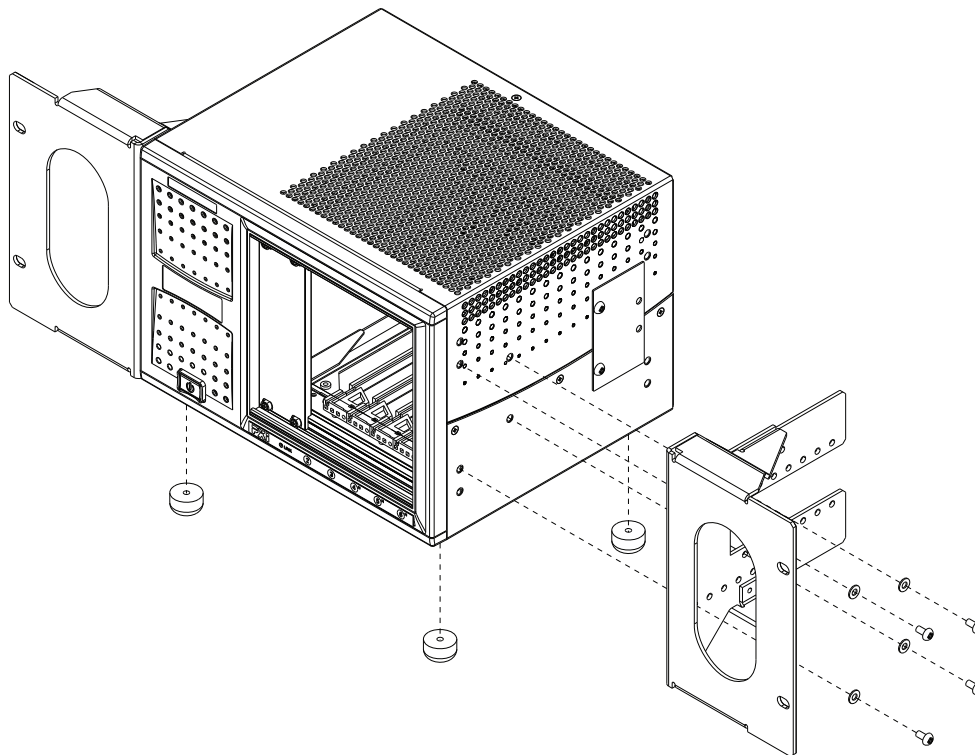

Figure 19 M9005A Chassis Rack Mount Kit Components

To mount the M9005A in an instrument rack, complete the following steps.

- 1** Remove the bottom feet and COA label plate (as required) from the M9005A chassis.
- 2** Install the mounting brackets onto the front or rear of each side of the chassis using the M4 × 8 panhead screws and lock washers supplied. Notice that you can recess the chassis in the cabinet rack at .5 in. increments.
- 3** Install the chassis in the instrument rack using four screws (not supplied).

Adapter Card Specifications

NOTE

These specifications are typical at 25 °C, unless otherwise stated, and are subject to change without notice.

Physical

- Dimensions
6.7 cm × 7.1 cm (2.6 in. × 2.8 in.)
- Maximum cable length 3 m
Slot requirements One slot (PCI Express, standard height or low profile)
- Compatibility
Fully compatible with the PCI Express Specification, Revision 1.0a
- Weight
0.04 kg (0.08 lb) typical

Power Requirements

Power Rail	Typical Current	Maximum Current
+3.3 V	360 mA	450 mA
+3.3 VAux	1 mA	10 mA
+12 V	0 A	0 A

Environmental

- Maximum altitude
2,000 m
- Pollution Degree
2
- For indoor use only.

Operating Environment

- Ambient temperature range
0 to 50 °C (Tested in accordance with IEC 60068-2-1 and IEC 60068-2-2.)
- Relative humidity range
20 to 80%, noncondensing (Tested in accordance with IEC 60068-2-56.)

CAUTION

Moisture condensation inside this product may lead to a permanent malfunction. If condensation is observed on the product, do not connect AC Mains power. When condensation is present, disconnect the AC Mains power cord and allow the product to stabilize at room temperature. Let dry for at least 60 minutes, or until all moisture has evaporated.

Moisture condenses when a product is significantly cooler than the surrounding air that holds traces of humidity. Typically this happens when there is sudden change in air temperature or humidity:

- Moving the product from an air-conditioned room to a warmer, humid environment.
- Moving the product from a very cold environment into a warm room with moderate humidity.

Storage Environment

- Ambient temperature range
-20 to 70 °C (Tested in accordance with IEC 60068-2-1 and IEC 60068-2-2.)
- Relative humidity range
10 to 95%, noncondensing (Tested in accordance with IEC 60068-2-56.)

6 Pinouts

This chapter describes the connector pinouts for the M9005A backplane.

Figure 20 illustrates the types of PXI Express connectors by providing a layout of a PXI Express Hybrid peripheral slot.

Table 4 shows the XP4 Connector Pinout for the PXI Express and Hybrid peripheral slots.

Table 5 shows the XP3 Connector Pinout for the PXI Express and Hybrid peripheral slots.

Table 6 shows the P1 Connector Pinout for the Hybrid peripheral slots.

For more detailed information, refer to the **PXI-5 PXI Express Hardware Specification**, Revision 2.0. Contact the PXI Systems Alliance for a copy of the specification.

Hybrid Slot Pinouts

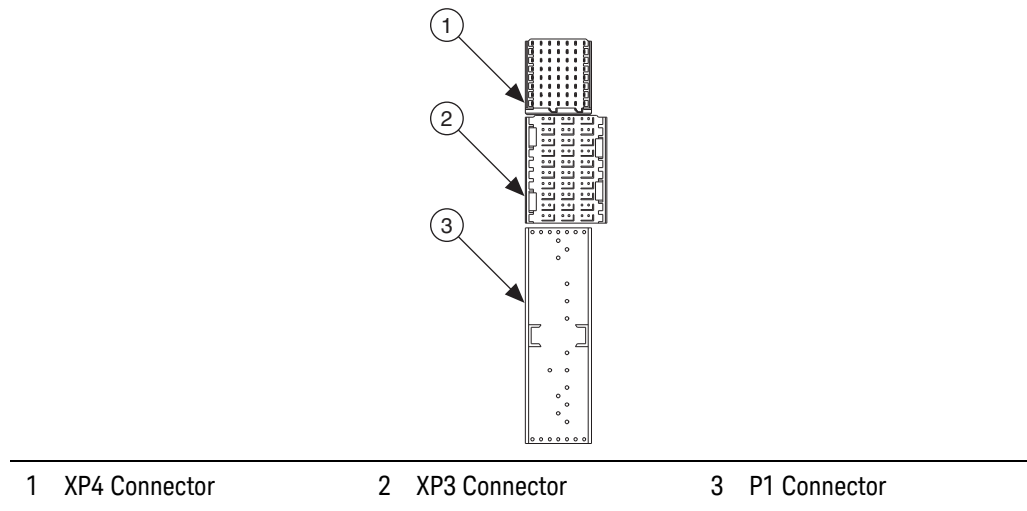

Figure 20 PXI Express System Hybrid Slot Layout

Table 4 XP4 Connector Pinout for the PXI Express/Hybrid Slot

Pin	Z	A	B	C	D	E	F
1	GND	GA4	GA3	GA2	GA1	GA0	GND
2	GND	5Vaux	GND	SYSEN#	WAKE#	ALERT#	GND
3	GND	12V	12V	GND	GND	GND	GND
4	GND	GND	GND	3.3V	3.3V	3.3V	GND
5	GND	PXI_TRIG3	PXI_TRIG4	PXI_TRIG5	GND	PXI_TRIG6	GND
6	GND	PXI_TRIG2	GND	ATNLED	PXI_STAR	PXI_CLK10	GND
7	GND	PXI_TRIG1	PXI_TRIG0	ATNSW#	GND	PXI_TRIG7	GND
8	GND	RSV	GND	RSV	PXI_LBL6	PXI_LBR6	GND

Table 5 XP3 Connector Pinout for the PXI Express/Hybrid Slot

Pin	A	B	ab	C	D	cd	E	F	ef
1	PXle_ CLK100+	PXle_ CLK100-	GND	PXle_ SYNC100+	PXle_ SYNC100-	GND	PXle_ DSTARC+	PXle_ DSTARC-	GND
2	PRSNT#	PWREN#	GND	PXle_ DSTARB+	PXle_ DSTARB-	GND	PXle_ DSTARA+	PXle_ DSTARA-	GND
3	SMBDAT	SMBCLK	GND	RSV	RSV	GND	RSV	RSV	GND
4	MPWRGD*	PERST#	GND	RSV	RSV	GND	1RefClk+	1RefClk-	GND
5	1PETp0	1PETn0	GND	1PERp0	1PERn0	GND	1PETp1	1PETn1	GND
6	1PETp2	1PETn2	GND	1PERp2	1PERn2	GND	1PERp1	1PERn1	GND
7	1PETp3	1PETn3	GND	1PERp3	1PERn3	GND	1PETp4	1PETn4	GND
8	1PETp5	1PETn5	GND	1PERp5	1PERn5	GND	1PERp4	1PERn4	GND
9	1PETp6	1PETn6	GND	1PERp6	1PERn6	GND	1PETp7	1PETn7	GND
10	RSV	RSV	GND	RSV	RSV	GND	1PERp7	1PERn7	GND

Table 6 P1 Connector Pinout for the Hybrid Slot

Pin	Z	A	B	C	D	E	F
25	GND	5V	REQ64#	ENUM#	3.3V	5V	GND
24	GND	AD[1]	5V	V(I/O)	AD[0]	ACK64#	GND
23	GND	3.3V	AD[4]	AD[3]	5V	AD[2]	GND
22	GND	AD[7]	GND	3.3V	AD[6]	AD[5]	GND
21	GND	3.3V	AD[9]	AD[8]	M66EN	C/BE[0]#	GND
20	GND	AD[12]	GND	V(I/O)	AD[11]	AD[10]	GND
19	GND	3.3V	AD[15]	AD[14]	GND	AD[13]	GND
18	GND	SERR#	GND	3.3V	PAR	C/BE[1]#	GND
17	GND	3.3V	IPMB_SCL	IPMB_SDA	GND	PERR#	GND
16	GND	DEVSEL#	GND	V(I/O)	STOP#	LOCK#	GND
15	GND	3.3V	FRAME#	IRDY#	BD_SEL#	TRDY#	GND
12-14	Key Area						
11	GND	AD[18]	AD[17]	AD[16]	GND	C/BE[2]#	GND
10	GND	AD[21]	GND	3.3V	AD[20]	AD[19]	GND
9	GND	C/BE[3]#	IDSEL	AD[23]	GND	AD[22]	GND
8	GND	AD[26]	GND	V(I/O)	AD[25]	AD[24]	GND
7	GND	AD[30]	AD[29]	AD[28]	GND	AD[27]	GND
6	GND	REQ#	GND	3.3V	CLK	AD[31]	GND
5	GND	BRSVP1A5	BRSVP1B5	RST#	GND	GNT#	GND
4	GND	IPMB_PWR	HEALTHY#	V(I/O)	INTP	INTS	GND
3	GND	INTA#	INTB#	INTC#	5V	INTD#	GND
2	GND	TCK	5V	TMS	TDO	TDI	GND
1	GND	5V	-12V	TRST#	+12V	5V	GND

Pinouts

Index

A

adapter card
specifications, 49

B

backplane
architecture (figure), 7
hybrid peripheral slots, 8
interoperability with
CompactPCI, 7
local bus, 9
overview, 7
PXI Express peripheral slot, 8
specifications, 43
system reference clock, 10
default behavior
(figure), 11
trigger bus, 9

C

cabling, 22
chassis ambient temperature
definitions, 16
chassis cooling considerations
ambient temperature
definitions, 16
chassis initialization file, 31
chassis number label, 28
checking LEDs for status, 23
CLK100 termination (figure), 10
CompactPCI
interoperability with M9005A
backplane, 7
configuration. *See* installation,
configuration, and operation
connecting to the power
supply, 17
cooling
air cooling of M9005A, 15

filler panel installation, 16
setting fan speed, 16
slot blocker installation, 16

E

EMC filler panel kit, 6
ExpressCard module, 19

F

fan, setting speed, 16
filler panel installation, 16

G

getting started, 1, 17
ground, connecting, 17

H

hybrid peripheral slots,
overview, 8
hybrid slot pinouts
P1 connector (table), 53
XP3 connector (table), 52
XP4 connector (table), 52

I

installation
cabling, 22
hardware, 19
of an ExpressCard module, 19
of an PCI Express host
card, 20
powering down the
system, 23
powering up the system, 23
installation, configuration, and
operation
chassis initialization file, 31
connecting safety ground, 17
filler panel installation, 16

module installation, 25
rack mounting, 16
setting fan speed, 16
site considerations, 14
slot blocker installation, 16
testing power up, 17
unpacking, 2
interface description, 8
interoperability with
CompactPCI, 7

L

local bus
local bus routing (figure), 9
routing (figure), 9

M

M9005A
backplane, 7
fan speed, setting, 16
key features, 3
maintenance. *See*
maintenance of M9005A
optional equipment, 6
rack mounting, 16
safety ground, connecting, 17
system reference clock
default behavior
(figure), 11
maintenance of M9005A, 33
cleaning
exterior, 34
interior, 34
preparation, 33
service interval, 33

O

overview, functional, 24

Index

P

PCI Express host card
 installation, 20
 pinouts, 51
 power switch, 17
 power up, testing, 17
PXI Express peripheral slot
 description, 8

R

rack mount kit, 6
rack mounting, 16

S

safety
 and caution notices, 14
 ground, connecting, 17
service interval, 33
setting fan speed, 16
slot blocker installation, 16
slot blockers, 6
specifications, M9005A
 AC input, 40
 acoustic emissions, 43
 backplane, 43
 chassis cooling, 41
 DC output, 40
 dimensions, 45
 environmental, 42
 shock and vibration, 42
system
 configuration, 26
 getting started, 17
system reference clock, 10
 default behavior (figure), 11

T

testing power up, 17
trigger bus, 9
troubleshooting, 35

U

unpacking
 host card, 18
 overview, 2



This information is subject to change
without notice

© Keysight Technologies 2016

Edition 1 August 2016

Published in USA



M9005-90001

www.keysight.com