

Keysight N8975A  
Option K40  
Blockdown Converter

Operating and  
Service Manual  
Special  
Supplement

# Notices

© Keysight Technologies, Inc.  
2007-2021

No part of this manual may be reproduced in any form or by any means (including electronic storage and retrieval or translation into a foreign language) without prior agreement and written consent from Keysight Technologies, Inc. as governed by United States and international copyright laws.

## Trademark Acknowledgments

## Manual Part Number

N8975-90002

## Edition

Edition 1, November 2021

Supersedes, April 2019

Printed in USA/Malaysia

Published by:  
Keysight Technologies  
1400 Fountaingrove Parkway  
Santa Rosa, CA 95403

## Warranty

THE MATERIAL CONTAINED IN THIS DOCUMENT IS PROVIDED "AS IS," AND IS SUBJECT TO BEING CHANGED, WITHOUT NOTICE, IN FUTURE EDITIONS. FURTHER, TO THE MAXIMUM EXTENT PERMITTED BY APPLICABLE LAW, KEYSIGHT DISCLAIMS ALL WARRANTIES, EITHER EXPRESS OR IMPLIED WITH REGARD TO THIS MANUAL AND ANY INFORMATION CONTAINED HEREIN, INCLUDING BUT NOT LIMITED TO THE IMPLIED WARRANTIES OF MERCHANTABILITY AND FITNESS FOR A PARTICULAR PURPOSE. KEYSIGHT SHALL NOT BE LIABLE FOR ERRORS OR FOR INCIDENTAL OR CONSEQUENTIAL DAMAGES IN CONNECTION WITH THE FURNISHING, USE, OR PERFORMANCE OF THIS DOCUMENT OR ANY INFORMATION CONTAINED HEREIN. SHOULD KEYSIGHT AND THE USER HAVE A SEPARATE WRITTEN AGREEMENT WITH WARRANTY TERMS

COVERING THE MATERIAL IN THIS DOCUMENT THAT CONFLICT WITH THESE TERMS, THE WARRANTY TERMS IN THE SEPARATE AGREEMENT WILL CONTROL.

## Technology Licenses

The hardware and/or software described in this document are furnished under a license and may be used or copied only in accordance with the terms of such license.

## U.S. Government Rights

The Software is "commercial computer software," as defined by Federal Acquisition Regulation ("FAR") 2.101. Pursuant to FAR 12.212 and 27.405-3 and Department of Defense FAR Supplement ("DFARS") 227.7202, the U.S. government acquires commercial computer software under the same terms by which the software is customarily provided to the public.

Accordingly, Keysight provides the Software to U.S. government customers under its standard commercial license, which is embodied in its End User License Agreement (EULA), a copy of which can be found at

<http://www.keysight.com/find/sweula>

The license set forth in the EULA represents the exclusive authority by which the U.S. government may use, modify, distribute, or disclose the Software. The EULA and the license set forth therein, does not require or permit, among other things, that Keysight: (1) Furnish technical information related to commercial computer software or commercial computer software documentation that is not customarily provided to the public; or (2) Relinquish to, or otherwise provide, the government rights in excess of these rights customarily provided to the public to use, modify, reproduce, release, perform, display, or disclose commercial computer software or commercial computer software

documentation. No additional government requirements beyond those set forth in the EULA shall apply, except to the extent that those terms, rights, or licenses are explicitly required from all providers of commercial computer software pursuant to the FAR and the DFARS and are set forth specifically in writing elsewhere in the EULA. Keysight shall be under no obligation to update, revise or otherwise modify the Software. With respect to any technical data as defined by FAR 2.101, pursuant to FAR 12.211 and 27.404.2 and DFARS 227.7102, the U.S. government acquires no greater than Limited Rights as defined in FAR 27.401 or DFAR 227.7103-5 (c), as applicable in any technical data.

## Safety Notices

### CAUTION

A **CAUTION** notice denotes a hazard. It calls attention to an operating procedure, practice, or the like that, if not correctly performed or adhered to, could result in damage to the product or loss of important data. Do not proceed beyond a CAUTION notice until the indicated conditions are fully understood and met.

### WARNING

A **WARNING** notice denotes a hazard. It calls attention to an operating procedure, practice, or the like that, if not correctly performed or adhered to, could result in personal injury or death. Do not proceed beyond a WARNING notice until the indicated conditions are fully understood and met.

## Where to Find the Latest Information

Documentation is updated periodically. For the latest information about these products, including instrument software upgrades, application information, and product information, browse to one of the following URLs, according to the name of your product:

<http://www.keysight.com/find/n8975a>

<http://www.keysight.com/find/n8975b>

To receive the latest updates by email, subscribe to Keysight Email Updates at the following URL:

<http://www.keysight.com/find/MyKeysight>

Information on preventing instrument damage can be found at:

[www.keysight.com/find/PreventingInstrumentRepair](http://www.keysight.com/find/PreventingInstrumentRepair)

## Is your product software up-to-date?

Periodically, Keysight releases software updates to fix known defects and incorporate product enhancements. To search for software updates for your product, go to the Keysight Technical Support website at:

<http://www.keysight.com/find/techsupport>



Table of Contents

**1. General Information**

Section 1.01 Introduction . . . . . 7

Section 1.02 Specifications . . . . . 7

Section 1.03 Safety Consideration . . . . . 8

Section 1.04 Description. . . . . 9

Section 1.05 Options. . . . . 9

Section 1.06 Accessories Supplied. . . . . 9

Section 1.07 Equipment Required but not Supplied . . . . . 10

Section 1.08 Electrical Equipment Available . . . . . 10

Section 1.09 Chassis Slide Mount Kit. . . . . 10

Section 1.10 Recommended Test Equipment . . . . . 10

Section 1.11 Symbols and Labels . . . . . 11

**2. Installation**

Section 2.01 Introduction . . . . . 13

Section 2.02 Initial Inspection . . . . . 13

Section 2.03 Power Requirements . . . . . 14

Section 2.04 Line Voltage and Fuse Selection. . . . . 14

Section 2.05 Power Cables. . . . . 14

Section 2.06 Mating Connectors . . . . . 15

Section 2.07 Operating Environment . . . . . 16

Section 2.08 Bench Operation . . . . . 16

Section 2.09 Rack Mounting . . . . . 16

Section 2.10 Storage and Shipment Environment. . . . . 16

Section 2.11 Packaging . . . . . 17

**3. Operation**

Section 3.01 Introduction . . . . . 19

Section 3.02 Panel Features . . . . . 19

Section 3.03 Front Panel Features . . . . . 20

Section 3.04 Rear Panel Features . . . . . 20

Section 3.05 Operating Characteristics . . . . . 22

Section 3.06 Operator's Maintenance . . . . . 22

Section 3.07 General Operating Instructions. . . . . 22

Section 3.08 Turn-On Procedure . . . . . 22

Section 3.09 Down Converter Operation . . . . . 23

Section 3.10 Calibration and Measurement Procedure (N8975A). . . . . 24

Section 3.11 Calibration and Measurement Procedure (N8975B). . . . . 26

Section 3.12 Sales and Service Offices . . . . . 31

# Contents

<b>4. Performance Tests</b>	
Section 4.01 Introduction . . . . .	33
Section 4.02 Equipment Required . . . . .	33
Section 4.03 Performance Test Record . . . . .	33
Section 4.04 Calibration Cycle . . . . .	33
Section 4.05 Performance Test Procedures . . . . .	34
Section 4.06 Frequency Range and Noise Figure (N8975A) . . . . .	34
Section 4.07 Frequency Range and Noise Figure (N8975B) . . . . .	37
Section 4.08 LO Frequency Accuracy . . . . .	40
<b>5. Adjustments</b>	
<b>6. Service</b>	
Section 6.01 Introduction . . . . .	45
Section 6.02 Service Sheets . . . . .	45
Section 6.03 Safety Considerations . . . . .	45
Section 6.04 Servicing the Instrument . . . . .	46
Section 6.05 Pozidrive Screwdrivers . . . . .	47
Section 6.06 Hardware . . . . .	47
Section 6.07 Assembly Locations . . . . .	47
Section 6.08 Parts and Cable Locations . . . . .	47
Section 6.09 Test Point Locations . . . . .	47
Section 6.10 Cover Removal . . . . .	48
Section 6.11 Cleaning Intervals . . . . .	48
Section 6.12 Six Month Cleaning . . . . .	48
Section 6.13 Twelve Month Cleaning . . . . .	49
Section 6.14 Overall Troubleshooting . . . . .	49
Section 6.15 Principles of Operation . . . . .	50
Section 6.16 Troubleshooting . . . . .	50
Section 6.17 Check List . . . . .	50
<b>7. Operating the Down Converter with the 8970B/8971C NF System</b>	
<b>8. Service Replaceable Parts</b>	
Section 8.01 Introduction . . . . .	57
Section 8.02 Accessories . . . . .	57

# 1 General Information

## Section 1.01 Introduction

This Operating and Service Manual contains information required to install, operate, test and service the Model N8975A Option K40 Block Down Converter. Throughout this manual the Model N8975A Option K40 will also be referred to as the Down Converter.

The Down Converter Operating and Service Manual has eight sections consisting of:

- Section 1 **General Information**
- Section 2 **Installation**
- Section 3 **Operation**
- Section 4 **Performance Tests**
- Section 5 **Adjustments**
- Section 6 **Service**
- Section 7 **Operating the Down Converter with the 8970B/8971C NF System**
- Section 8 **Service Replaceable Parts**

## Section 1.02 Specifications

Instrument specifications for the Down Converter are listed in **Table 1-1**. These specifications are the performance standards against which the instrument may be tested. Supplemental characteristics are listed in **Table 1-2**. Supplemental characteristics are not warranted specifications, but are typical characteristics included as additional information for the user.

Table 1-1

Specifications

Characteristics	Performance Limits	Conditions
Input Frequency	26.5 - 40 GHz	

Table 1-1

**Specifications**

Characteristics	Performance Limits	Conditions
Output Frequency	18 - 4.5 GHz	
LO Frequency	44.5 GHz $\pm$ 50 MHz	
Noise Figure	20 dB Maximum <15 dBm Typ	
Temperature Range		
Specification Range	15° to 35 °C	
Operating Range	0 to 50 °C	
Storage	-40° to +70 °C	

Table 1-2

**Supplemental Characteristics**

Characteristics	Performance Limits	Conditions
Conversion Gain	18 dB Nominal	@33 GHz
Humidity	20 - 80% R.H.	@40 °C
Altitude	2000 Meters MAX (6562ft)	
Power Consumption	60W Max.	50 - 60Hz 100-240V AC
Dimensions	88.5mm H x 212.6mm W x 348.3mm D	Excluding front and rear panel protrusions
Weight	Net 4.5 Kg (9.9 lbs) Shipping 8.4 Kg (18.5 lbs)	

**CAUTION**

This instrument is designed for use in an Installation Category II and Pollution Degree 2 environment, per IEC 61010.

## Section 1.03 Safety Consideration

This instrument has been designed and tested in accordance with IEC publication 61010-1:2001, Safety Requirements for Electrical Equipment for Measurement, Control, and Laboratory Use, and has been supplied in a safe condition. The instruction documentation contains information and warnings that must be followed by the user to ensure safe operation and to maintain the instrument in a safe condition.



**WARNING**

This is a safety Class 1 product (provided with a protective earthing ground incorporated in the power cord). The mains plug shall only be inserted in a socket outlet provided with a protective earth contact. Any interruption of the protective conductor inside or outside the instrument is likely to make the instrument dangerous. Intentional interruption is prohibited.

---

## Section 1.04 Description

The N8975A Option K40 Block Down Converter is designed to be used with the N8975A or N8975B Noise Figure Analyzer. The Option K40 extends the frequency range of the N8975A/B by down converting the 26.5 GHz to 40 GHz frequency band. In addition to the N8975A/B a Noise Source (346C K01 recommended) is required for a complete Noise Figure measurement system.

The Down Converter uses an internal 44.5 GHz LO for down conversion of the 26.5 GHz to 40 GHz input. The resulting 18 GHz to 4.5 GHz signal is processed by the N8975A/B Noise Figure Analyzer to give information about the noise figure and gain of a Device Under Test (DUT).

## Section 1.05 Options

There are no electrical or mechanical options to the N8975A Option K40 Down Converter.

## Section 1.06 Accessories Supplied

The N8975A Option K40 Down Converter is supplied with a three wire power cable. Different cables are available for different power mains configurations. Check with you local Keysight Technologies office for descriptions and part numbers for these cables.

A rack mount kit is supplied for mounting the N8975A Option K40 in a standard 19 inch EIA rack. The part number for the rack mount kit is 5063-9240.

An RF cable, part number 08971-60128 is supplied. This cable is used to connect the Down Converter RF OUTPUT to the NFA INPUT.

An APC 2.4 mm female to female coax adapter is supplied (part number 1250-2188). This is supplied to connect the 346C K01 to the Down Converter RF Input for calibration.

## Section 1.07 Equipment Required but not Supplied

To form a noise figure measurement system for measurements in the 26.5 to 40 GHz band the additional equipment required:

- N8975A/B Noise Figure Analyzer
- 346C K01 Noise Source

## Section 1.08 Electrical Equipment Available

Waveguide/Coax Adapters R281A WR28 to 2.4mm APC

Waveguide Noise Source R347B 26.5 to 40GHz

## Section 1.09 Chassis Slide Mount Kit

This kit is used to install one or more instruments in a sliding support shelf, Order shelf part number 5063-9255, and slide kit 1494-0015 (for a single instrument, also order filler panel 5002-3999).

## Section 1.10 Recommended Test Equipment

**Table 1-3** lists the test equipment recommended for use in testing, adjusting and servicing the Down Converter. The Critical Specification column describes the essential requirement for each piece of test equipment. Other equipment may be substituted if it meets or exceeds the critical specifications.

The recommended model column may suggest more than one model. The first model shown is usually the least expensive, single-purpose model. Alternate models are suggested, with additional features, that would be a better choice in some applications.

Table 1-3

**Recommended Test Equipment**

<b>Instrument</b>	<b>Critical Specification</b>	<b>Recommended Model</b>
Noise Figure Analyzer	Noise Figure Measurements 4.5-18 GHz	N8975A/B
Synthesizer	26.5 - 40 GHz 0 dBm	83640A
Noise Source	ENR >9dB 10 MHz - 40 GHz	346C #K01
Spectrum Analyzer	Signal Analysis 2-18 GHz	E4407B, 8566A/B
Coaxial Adapter	APC 2.4mm female to 3.5mm female	1250-2277

## Section 1.11 Symbols and Labels



The Caution, risk of danger symbol. The product is marked with this symbol when it is necessary for the user to refer to the instructions in the supplied documentation.



The out position of a bistable push control switch.



The in position of a bistable push control switch.



The ON/OFF symbol.



The ON symbol.



Indicates a Protective Conductor Terminal that must be connected to earth ground before operating the equipment protects against electrical shock in case of a fault.

**WARNING**

Warning denotes a hazard. It calls attention to a procedure which, if not correctly performed or adhered to, could result in injury or loss of life. Do not proceed beyond a warning note until indicated conditions are fully understood and met.

**CAUTION**

Caution denotes a hazard. It calls attention to a procedure which, if not correctly performed or adhered to, could result in damage to or destruction of the instrument. Do not proceed beyond a caution note until the indicated conditions are fully understood and met.

ICES/NMB-001  
ISM GRP.1 CLASS A

This ISM device complies with Canadian ICES-001. Cet appareil ISM est conforme à la norme NMB-001 du Canada.



The Caution, risk of danger symbol. The product is marked with this symbol when it is necessary for the user to refer to the instructions in the supplied documentation.



The CE mark shows that the product complies with all applicable European Directives.

General Information  
Section 1.11 Symbols and Labels



The UK conformity mark is a UK government owned mark. Products showing this mark comply with all applicable UK regulations.



The CSA mark is a registered trademark of the Canadian Standards Association.



ICES/ISM Label.

This is a space saver label that combines two markings – CAN ICES and ISM.



The RCM mark is a registered trademark of the Australian Communications Authority. This signifies compliance with the Australian EMC Framework Regulations under the terms of the Radio Communications Act of 1992.



This is the symbol for an Industrial, Scientific and Medical, Group 1 Class product.



The crossed-out wheeled bin symbol indicates that separate collection for waste electric and electronic equipment (WEEE) is required, as obligated by the EU DIRECTIVE and other National legislation. Please refer to [www.keysight.com/go/takeback](http://www.keysight.com/go/takeback) to understand your trade-in options with Keysight, in addition to product takeback instructions.



This symbol not only indicates the presence of hazardous or toxic substances above the MCV, but also specifies that the material/product is recyclable and should not be "thrown away casually", as well as the length of the environmental protection use period EPUP (Environmental Protection Use Period) is stated in the number of years, starting with the date of manufacture, located in the center of the symbol.



**South Korean Class A EMC Declaration**  
A 급 기기 ( 업무용 방송통신기자재 )

이 기기는 업무용 (A 급) 전자파적합기기로서 판매자 또는 사용자는 이 점을 주의하시기 바라 며 , 가정외의 지역에서 사용하는 것을 목적으로 합니다 .

This equipment is Class A suitable for professional use and is for use in electromagnetic environments outside of the home.

## 2 Installation

### Section 2.01 Introduction

This section provides the information needed to install the N8975A Option K40 Down Converter. Included is information pertinent to initial inspection, power requirements, line voltage selection, power cables, interconnection, environment, storage and shipment.

#### WARNING

If this instrument is not used as specified, the protection provided by the equipment could be impaired. This instrument must be used in a normal condition (in which all means for protection are intact) only.

---

#### WARNING

Appliance Coupler (mains input powercord) is the power disconnect device. Do not position the instrument such that access to the coupler is impaired.

---

### Section 2.02 Initial Inspection

#### WARNING

To avoid hazardous electrical shock, do not perform electrical tests when there are signs of shipping damage to any portion of the outer enclosure (covers, panels, connectors).

---

Inspect the shipping container for damage. If the shipping container or cushioning material is damaged, it should be kept until the contents of the shipment have been checked for completeness and the instrument has been checked mechanically and electrically. The contents of the shipment should include the accessories specified in **“Section 1.06 Accessories Supplied” on page 9**. Procedures for checking electrical performance are given in **Chapter 4, “Performance Tests”, on page 33**. If the contents are incomplete or if there is mechanical damage or defect notify the nearest Keysight Technologies office. If the shipping container is damaged, or the cushioning material shows signs of stress, notify the carrier as well as the Keysight Technologies office. Keep the shipping material for carrier's inspection.

## Section 2.03 Power Requirements

The N8975A Option K40 Down Converter requires a power source of between 100V AC to 240 V AC single phase. Line frequency is 50-60Hz. The rated power consumption is 100V AC 45VA and 240V AC 70VA maximum.

### WARNING

This is a safety class 1 product (that is, provided with a protective earth terminal). An un-interruptable safety earth ground must be provided from the main power source to the product input wiring terminals, power cord or supplied power cord set.

Whenever it is likely that the protection has been impaired, the product must be made inoperative and be secured against any unintended operation.

---

## Section 2.04 Line Voltage and Fuse Selection

### CAUTION

This instrument has an auto-ranging line voltage input, be sure the supply voltage is within the specified range. The mains supply voltage fluctuations are not to exceed  $\pm 10\%$  of the nominal supply voltage.

---

The Down Converter will operate with voltages between 100V AC and 240V AC and so requires no switching or change of fuse.

## Section 2.05 Power Cables

### WARNING

Before connecting this instrument, the protective earth terminals of this instrument must be connected to the protective conductor of the line (Mains) power cable. The line plug shall only be inserted in a socket outlet provided with a protective earth contact. The protective action must not be negated by the use of an extension cord (power cable) without a protective conductor (grounding). Grounding one conductor of a two conductor outlet is not sufficient protection.

---

This instrument is equipped with a three-wire power cable. When connected to an appropriate AC power receptacle, this cable grounds the instrument cabinet. The type of power cable plug shipped with each instrument depends on the country of destination. See [Figure 2-1](#) Power Cable and Line (Mains) Plug part numbers, for the part numbers of available power cables. Cables are

available in different lengths or with right angle plugs to the instrument. Check with your nearest Keysight Technologies service center for descriptions and part numbers of these cables.



External Protective Earth Terminal

While this is a Class I product, provided with a protective earthing conductor in a power cord, an external protective earthing terminal has also been provided. This terminal is for use where the earthing cannot be assured. At least an 18AWG earthing conductor should be used in such an instance, to ground the instrument to an assured earth terminal.

Figure 2-1 Power Cable and Mains Plug Part Numbers

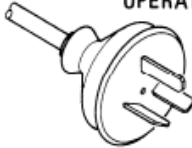
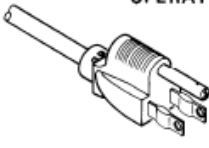
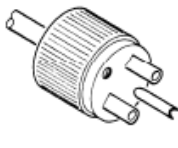
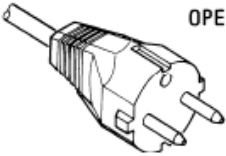
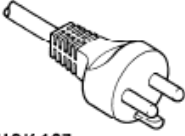
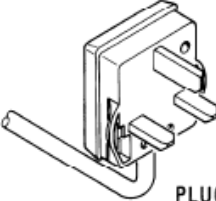
<p style="text-align: center;"><b>220/240V OPERATION</b></p>  <p><b>PLUG*:</b> SEV 1011.1959-24507  <b>TYPE 12</b>  <b>CABLE*:</b> 8120-2104</p>	<p style="text-align: center;"><b>220/240V OPERATION</b></p>  <p><b>PLUG*:</b> NZSS 198/AS C112  <b>CABLE*:</b> 8120-1369</p>	<p style="text-align: center;"><b>100/120V OPERATION</b></p>  <p><b>PLUG*:</b> NEMA 5-15P  <b>CABLE*:</b> 8120-1378</p>	<p style="text-align: center;"><b>220/240V OPERATION</b></p>  <p><b>PLUG*:</b> NEMA 6-15P  <b>CABLE*:</b> 8120-0698</p>
<p style="text-align: center;"><b>220/240V OPERATION</b></p>  <p><b>PLUG*:</b> CEE7-VII  <b>CABLE*:</b> 8120-1689</p>	<p style="text-align: center;"><b>220/240V OPERATION</b></p>  <p><b>PLUG*:</b> DHCK 107  <b>CABLE*:</b> 8120-2956</p>	<p style="text-align: center;"><b>220/240V OPERATION</b></p>  <p><b>PLUG*:</b> BS 1363A  <b>CABLE:</b> 8120-1351</p>	
<p><b>*The number shown for the plug is the industry identifier for the plug only.                  The number shown for the cable is a part number for a complete cable including the plug.</b></p>			

## Section 2.06 Mating Connectors

Mating connectors used with the Down Converter are 50Ω, 2.4mm APC male RF INPUT connector and a 50Ω, 3.5mm APC male RF OUTPUT connector located on the front panel. Mating connectors used with the Down Converter should be of the same type and US MIL-C-39012 compatible.

## Section 2.07 Operating Environment

The operating environment for the Down Converter should be maintained within the following limitations:

Specified Temperature Range	15 °C to 35 °C
Operating temperature range	0 °C to 50 °C
Humidity	20% to 80% RH @40 °C
Altitude	<2000 meters (6562 feet)

For indoor use only.

### CAUTION

**VENTILATION REQUIREMENTS** When installing the instrument in a cabinet, the convection into and out of the instrument must not be restricted. The ambient temperature (outside the cabinet) must be less than the maximum operating temperature of the instrument by 4 °C for every 100 Watts dissipated in the cabinet. If the total power dissipated in the cabinet is greater than 800 Watts, then forced convection must be used.

## Section 2.08 Bench Operation

The instrument has rubber feet for convenience in bench operation.

## Section 2.09 Rack Mounting

Rack mounting information is provided with the rack mount kit that is supplied with the instrument.

## Section 2.10 Storage and Shipment Environment

The instrument should be stored in a clean, dry environment. The following environment limitations apply to both storage and shipment: limitations:

Temperature	-40 °C to +70 °C
Humidity	<95% relative
Altitude	<15,300 Meters (50,000 feet)



## Section 2.11 Packaging

The instrument should be stored in a clean, dry environment. The following environment limitations apply to both storage and shipment limitations:

### Original Packaging:

Containers and materials identical to those used in factory packaging are available through Keysight Technologies offices. Mark the container "FRAGILE" to assure careful handling. In any correspondence refer to the instrument by model number and full serial number.

### Other Packing:

The following general instructions should be used for re-packaging with commercially available materials:

- Wrap the instrument in heavy paper or plastic. If shipping to a Keysight Technologies office or service center, attach a tag indicating the type of service required, return address, model number, and full serial number.
- Use a strong shipping container. A double wall carton made of 2.4 MPa (350 psi) test material is adequate.
- Use enough shock absorbing material 75 to 100mm (3 to 4 inches) thick around all sides of the instrument to provide a firm cushion and prevent movement in the container.
- Protect the front panel with an appropriate type of cushioning material to prevent damage during shipment.
- Seal the container.
- Mark the container "FRAGILE" to assure careful handling.
- In any correspondence, refer to the instrument by model number and full serial number.



## 3 Operation

### Section 3.01 Introduction

This section provides complete operating information for the Down Converter. Included in this section are descriptions of the front and rear panel connectors and indicators, maintenance, and operating instructions.

When using the Down Converter with a N8975A/B Noise Figure Analyzer, refer to the N8975A/B Operating and Service Manual for additional operating information.

When using the Down Converter with the 8970B/8971C noise figure system a 20 dB attenuator connected to the output of the Down Converter is required so that the nominal gain of the Down Converter plus attenuator is approximately 0 dB.

### Section 3.02 Panel Features

The front and rear panel features are shown in **Figure 3-1**.

Any explanation of all connectors and indicators is given in **Section 3.03 Front Panel Features** and **Section 3.04 Rear Panel Features**.

## Section 3.03 Front Panel Features

**a. RF Input (J1)**

A 2.4mm female connector provides the input to the Down Converter. The maximum input to avoid damage, when used with an N8975A/B Noise Figure Analyzer, is +10 dBm. The impedance is 50Ω. Generally, the noise source is attached to this connector for calibration, and the device under test is attached to this connector for noise figure measurement.

**b. RF Output (J2)**

A 3.5 mm male connector provides the down converted output to the N8975A/B. Signals of 26.5 GHz to 40 GHz at the RF INPUT are mixed with a fixed 44.5 GHz LO in the N8975A Option K40 to produce the down converted 18 GHz to 4.5 GHz output.

**NOTE**

The LOWER SIDEBAND is down converted.

---

**c. Power (S1)**

This switch turns the instrument power supply between stand-by and on. When it is in the ON (1) position the instrument is operational.

## Section 3.04 Rear Panel Features

**a. Power (MP1)**

Line power module connects the power cord to the Down Converter and contains the line over current protection fuse. Center conductor is a chassis connection for safety earth ground.

**b. Fuse**

An F3.15AH fuse is installed for all voltage supplies.

Figure 3-1 Front and Rear Panel

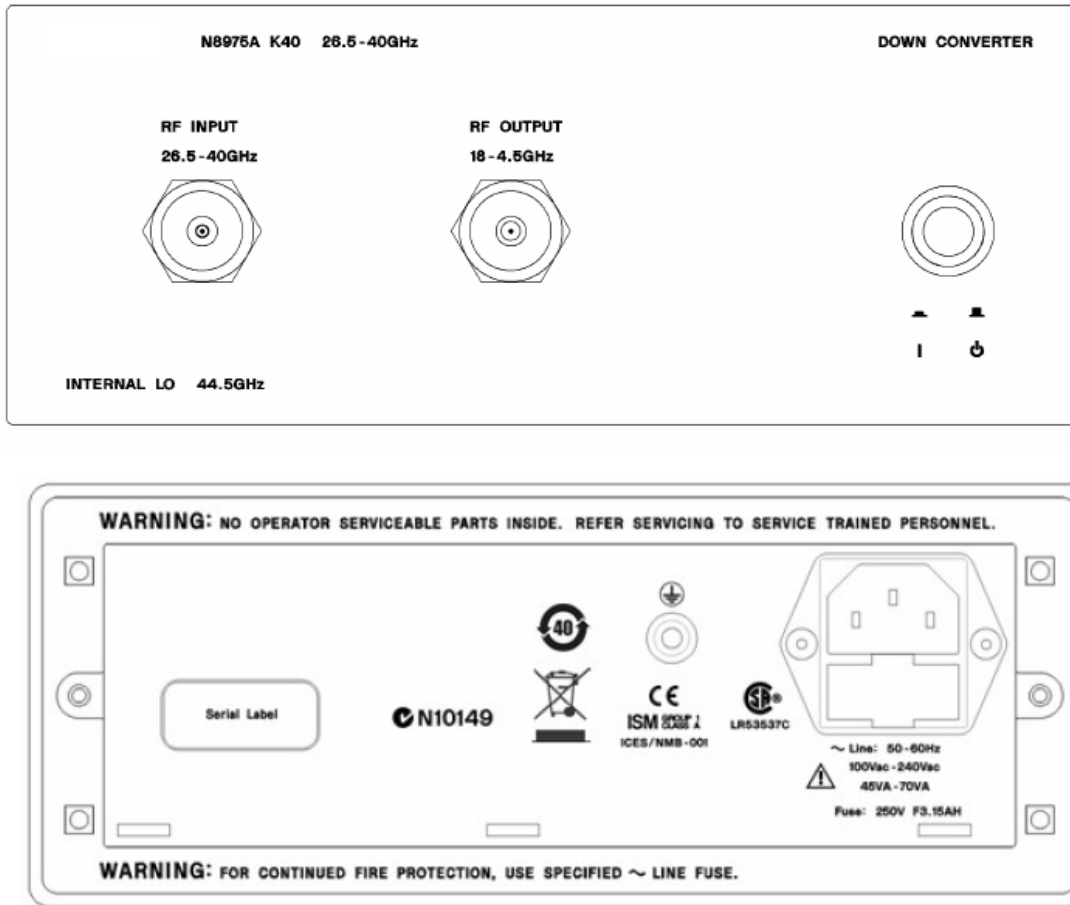

## Section 3.05 Operating Characteristics

The Down Converter, when used with N8975A/B Noise Figure Analyzer, extends the frequency up into the 26.5–40 GHz band.

Down Converter Performance Specifications and Supplemental Characteristics are contained in [Table 1-1](#) and [Table 1-2](#).

## Section 3.06 Operator's Maintenance

### WARNING

For continued protection against fire hazard, replace the line fuse only with the same type and rating (F3.15AH, 250V). The use of other fuses or materials is prohibited.

---

Replacing a defective primary fuse, Keysight Part Number 2110-0957. This fuse is located in the line module assembly.

Clean the cabinet, Using a damp cloth only.

### WARNING

No Operator serviceable parts inside. Refer servicing to qualified personnel. To prevent electric shock do not remove covers.

---

## Section 3.07 General Operating Instructions

### WARNING

Before the instrument is switched on, all protective earth terminals, extension cords, auto transformers, and devices connected to the instrument should be connected to a protective earth grounded socket. Any interruption of the protective earth grounding will cause a potential shock hazard that could result in personal injury.

---

## Section 3.08 Turn-On Procedure

If the Down Converter is not plugged in, follow these instructions:

1. Check the line voltage is correct to operate the Down Converter.
2. Plug in the power cable.
3. Press the line switch on the front panel to ON.

## Section 3.09 Down Converter Operation

The Down Converter must be used with a N8975A/B Noise Figure Analyzer for a complete 26.5 GHz to 40 GHz noise figure measurement system.

As an example, the following procedure would be used to calibrate and measure the noise figure and gain of an amplifier from 26.5 GHz to 40 GHz every 500 MHz.

### 1. ENR Data

Before noise figure and gain measurements can be made, the ENR of the Noise Source must be entered into the N8975A/B. Information on how to enter the data is found in the ENR Table Entry procedure in Chapter 2 in the section on "Entering Excess Noise Ratio Data" of the N8975A Users Guide (N8972-90115). It is not necessary to input all ENR data points, but the data must cover the measurement frequency.

### 2. Connections - Calibration

To calibrate the N8975A/B and the K40 Down Converter as a system make the following connections as shown in [Figure 3-2](#) or [Figure 3-3](#):

- Connect 346C K01 Noise Source to the K40 RF INPUT using adapter 1250-2188.
- Connect the K40 RF OUTPUT to the N8975A/B INPUT using cable 08971-60128.
- Connect the N8975A/B Noise Source Drive Output to the 346C K01 INPUT.

## Section 3.10 Calibration and Measurement Procedure (N8975A)

**NOTE**

Section 3.10 is specifically for the N8975A. For the N8975B Setup and Calibration Procedure proceed to “[Section 3.11 Calibration and Measurement Procedure \(N8975B\)](#)”.

### Calibration Procedure

Figure 3-2 N8975A Test Set-up for Calibration and Measurement of Noise Figure

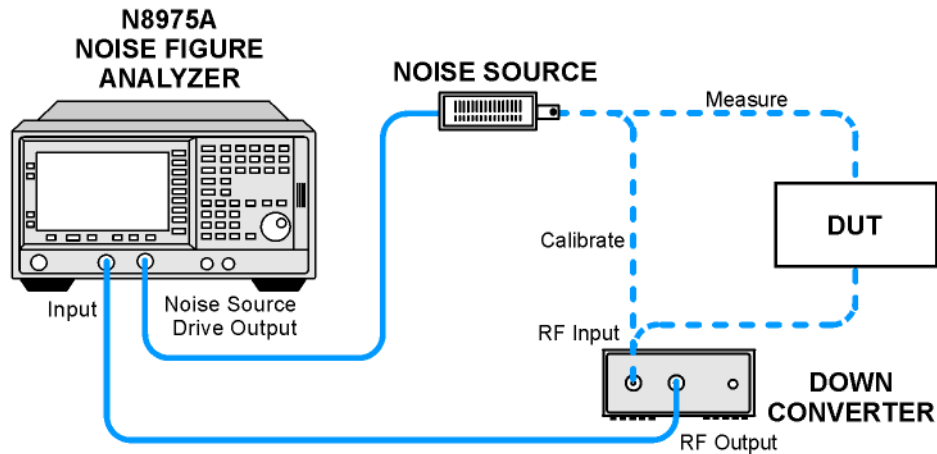

1. Switch on the N8975A and the K40 Down Converter allow half an hour to warm up.
2. Press [System] then softkey {External LO} then {Max Freq} and enter [5] [0] {GHz}.
3. Press key [Meas Mode] then softkey {Amplifier} then key [Tab→].
4. Press Sys Downconv softkey {On}. Note LO Mode should be "Fixed".
5. Press key [Mode Setup]. Note LO Frequency should be highlighted, if not press [Tab→] key until it is.



6. Enter using numeric keys [4] [4] [.] [5] then softkey {GHz}. Note IF Frequency is blank, Sideband should be LSB, LO Control should be Off. If not use the [Tab→] key to highlight the parameter to change and then press the appropriate softkey.
7. Press key [Frequency/Points] then softkey {Start Freq} and enter [2] [6] [.] [5] {GHz} then softkey {Stop Freq} and enter [4] [0] {GHz}.
8. Press softkey {More 1 of 2} then softkey {Points} and enter [2] [8] [Enter].
9. Press [System] then softkey {Alignment} then softkey {Alignment Mode} to Point.

**NOTE**

Alignment should be ON.

- 
10. Press key [Averaging/Bandwidth] then softkey {Averages} and enter [3] [2] [Enter]. Press softkey {Averaging} to On.
  11. Press [Calibrate] twice and wait for calibration to complete.

## Measurement Procedure

### 1. Measurement Procedure

After calibration disconnect the noise source from the RF INPUT of the K40 Down Converter. Connect the noise source output to the input of the device under test (DUT) and the output of the DUT to the K40 Down Converter RF INPUT, as shown in [Figure 3-2](#). Press [Restart] and wait for the measurement sweep to complete. Record the results.

**NOTE**

For the Noise Figure Measurement System specifications to be valid, the measurement must use the same START FREQ, STOP FREQ and STEP SIZE that was used for calibration. None of the calibrated points can be skipped. Also, the measurement must be done in the same direction as the calibration, for example, from start frequency to stop frequency.

### 2. Measurement Accuracy

The noise figure of the N8975A K40 test system is in the order of 15 dB. So the noise figure plus Gain of the DUT must be much higher than 15 dB for accurate measurement uncertainty. If the DUT has low gain and low noise figure then a pre-amplifier will be required as part of the system and included in the calibration so that the measurement uncertainty is reduced.

## Section 3.11 Calibration and Measurement Procedure (N8975B)

**NOTE**

Section 3.11 is specifically for the N8975B. For the N8975A Setup and Calibration Procedure proceed to “[Section 3.10 Calibration and Measurement Procedure \(N8975A\)](#)”.

### Calibration Procedure

Figure 3-3 N8975B Test Set-up for Calibration and Measurement of Noise Figure

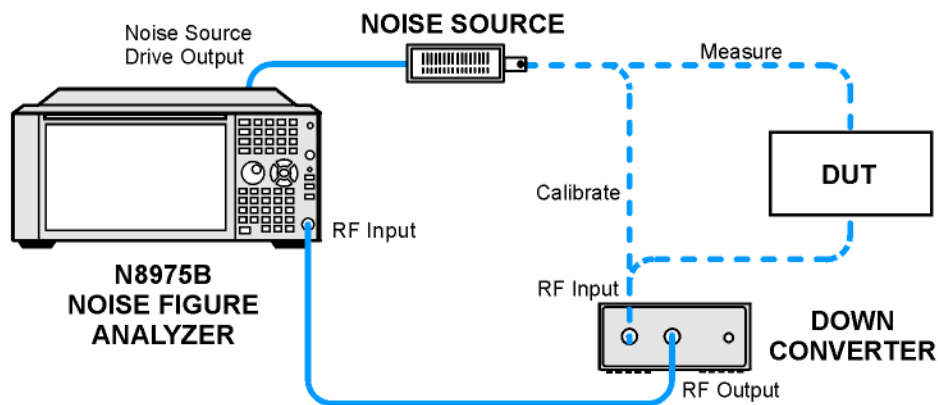

1. Switch on the N8975B and the K40 Down Converter and allow 30 minutes to warm up.
2. Press the [Meas Setup] hardkey then {DUT Setup & Calibration} softkey.

3. Referring to the image below, tap the screen in the Sys Downconverter block.

Figure 3-4

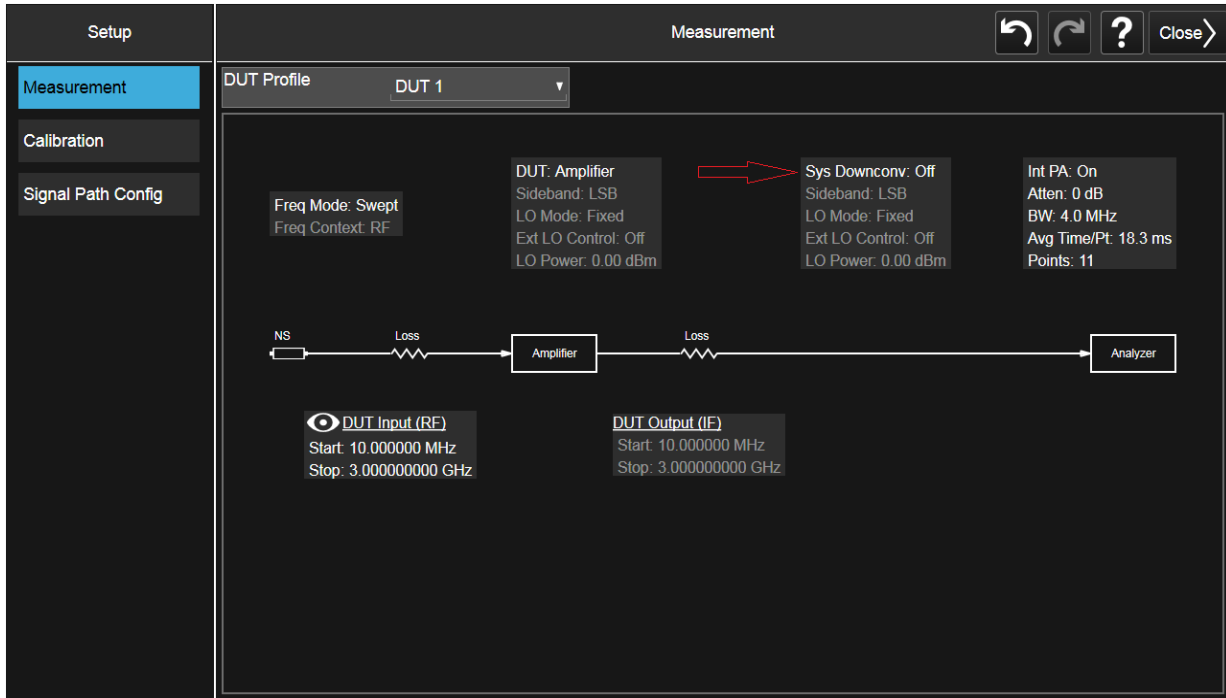

4. Toggle the Sys Downconv switch to On.
5. Set the Downconverter properties as follows:
  - a. Sideband → USB
  - b. LO Mode → Fixed
  - c. Ext LO Control → Off
  - d. LO Power → 0.00 dBm

6. See the figure below to verify the settings are correct and then mouse click or tap outside the Sys Downconverter parameter window.

Figure 3-5

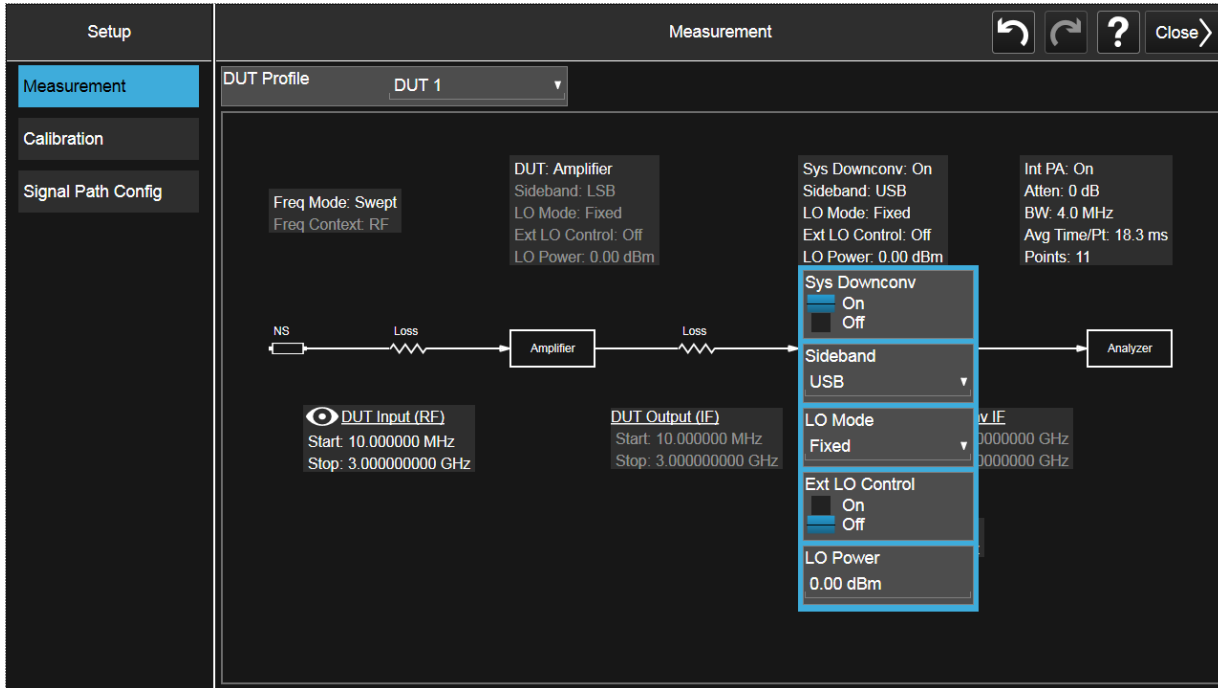

7. Tap Sys Downconv LO Block and using the numeric keypad enter the following Sys Downconverter LO frequency:
  - N8975AZ-K40, LO frequency is 44.5 GHz
8. Tap DUT Input (RF) block and change the start and stop frequency to the corresponding block downconverter model being used:
  - N8975AZ-K40, start frequency = 26.5 GHz, stop frequency = 40 GHz
9. Tap the Int PA block and change the point from 11 to 28.

10. See the figure below to verify the settings are correct then select Close.

Figure 3-6

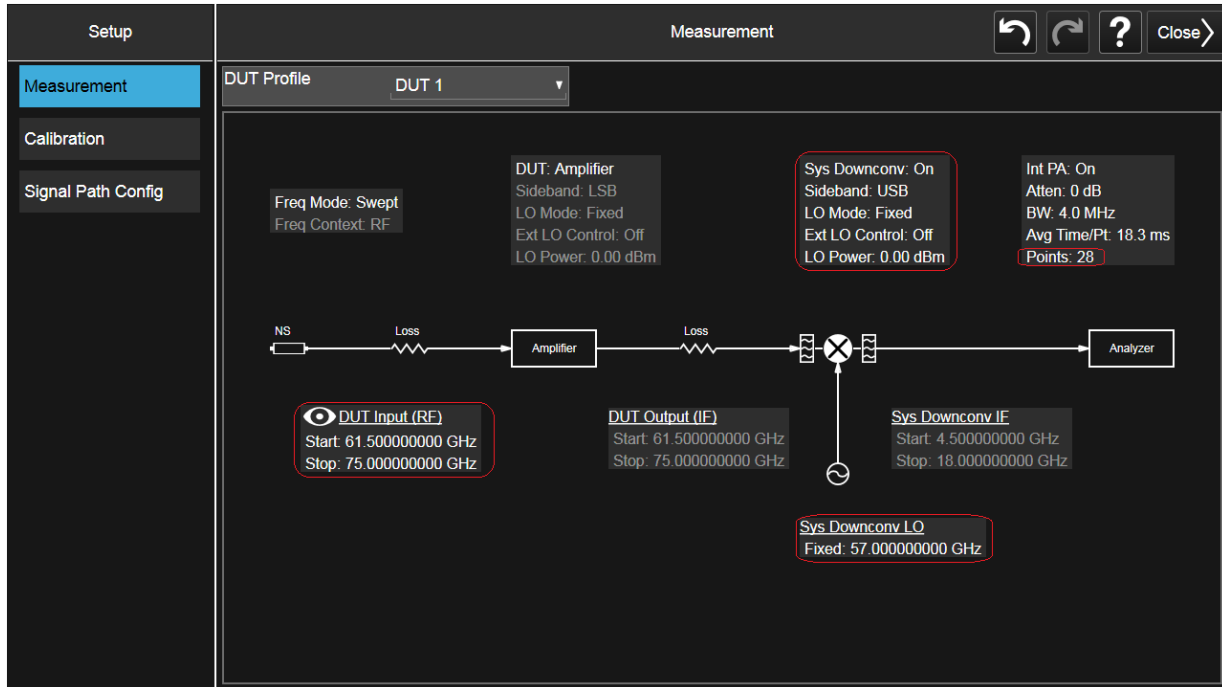

11. Verify you are in the Meas Setup menu. If not, press the [Meas Setup] hardkey.
12. Toggle the Averaging switch to On.
13. Tap Avg/Hold Num and change the number to 32.
14. Tap the {Calibrate} softkey, then select OK and wait for the calibration to complete.

## Measurement Procedure

### 1. Measurement Procedure

After calibration disconnect the noise source from the RF INPUT of the K40 Down Converter. Connect the noise source output to the input of the device under test (DUT) and the output of the DUT to the K40 Down Converter RF INPUT, as shown in [Figure 3-3](#). Press [Restart] and wait for the measurement sweep to complete. Record the results.

#### NOTE

For the Noise Figure Measurement System specifications to be valid, the measurement must use the same START FREQ, STOP FREQ and STEP SIZE that was used for calibration. None of the calibrated points can be skipped. Also, the measurement must be done in the same direction as the calibration, for example, from start frequency to stop frequency.

---

### 2. Measurement Accuracy

The noise figure of the N8975A K40 test system is in the order of 15 dB. So the noise figure plus Gain of the DUT must be much higher than 15 dB for accurate measurement uncertainty. If the DUT has low gain and low noise figure then a pre-amplifier will be required as part of the system and included in the calibration so that the measurement uncertainty is reduced.

## Section 3.12 Sales and Service Offices

An up-to-date list of Keysight Offices is available through the Keysight Website at URL: <http://www.keysight.com>.





## 4 Performance Tests

### Section 4.01 Introduction

The procedures in this section test the Down Converter's electrical performance using the specifications of **Table 1-1** as performance standards. These tests are suitable for incoming inspection, troubleshooting, and preventative maintenance. All tests can be performed without access to the interior of the Down Converter.

### Section 4.02 Equipment Required

Equipment required for the performance tests is listed in **Table 1-3**, Recommended Test Equipment. Any equipment that satisfies the critical specifications given in the table may be substituted for the recommended models.

### Section 4.03 Performance Test Record

Results of performance tests may be recorded in **Table 4-1**, Performance Test Record. This lists all test specifications and the acceptable limits for each specification. Results recorded at incoming inspection can be used for comparison in periodic maintenance and troubleshooting, and after repairs.

### Section 4.04 Calibration Cycle

This instrument requires periodic verification of performance. Depending of the use and environmental conditions, the instrument should be checked, using the performance tests, at least once a year.

## Section 4.05 Performance Test Procedures

It is assumed that the person performing the following test understands how to operate the test equipment. Equipment settings are stated in general terms. It is also assumed that the technician will select the cables and adapters required to complete the test set-ups illustrated in this section.

### NOTE

To consider the performance test valid, the following conditions must be met:

1. The Down Converter and all test equipment must have a minimum of 30 minutes warm up time.
  2. The line voltage must be 100 to 240 VAC.
  3. The Ambient temperature must be +15° C to +35 °C, from start of the warm up period to the completion of all tests.
- 

## Section 4.06 Frequency Range and Noise Figure (N8975A)

The Noise Figure Analyzer uses Measurement Mode DUT is Down Converter in fixed LO mode to measure the noise figure of the N8975A Option K40.

### Specification

Frequency Range	26.5 GHz to 40 GHz
Noise Figure	20 dB Maximum

### Equipment

Noise Figure Analyzer	N8975A
Noise Source	346C Option K01
Adapter APC 2.4mm female to APC 3.5mm female)	1250-2277

## Calibration Procedure

1. Connect the test equipment as shown in **Figure 4-1** for calibration.

**Figure 4-1** N8975A Test Set-up for Calibration

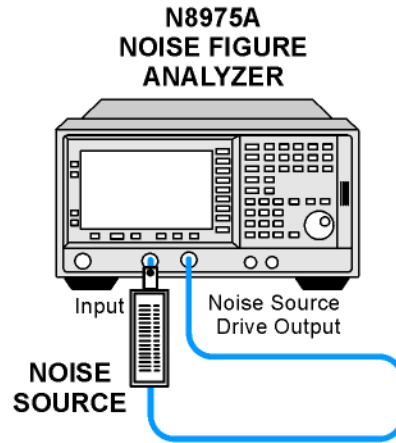

2. Switch on the N8975A and the N8975A K40 Down Converter allow half an hour to warm up.
3. Preset all instruments, then enter the ENR data for the 346C Option K01 into the N8975A. See chapter 3 ENR Data for details. Only data from 4 to 18 GHz and 26.5 to 40 GHz is needed for the performance test.
4. From N8975A, press [System] then softkey {External LO} then {Max Freq} and enter [5] [0]{GHz}.
5. Press key [Meas Mode] then softkey {Downconv}. Note LO Mode should be "Fixed".
6. Press key [Mode Setup]. Note LO Frequency should be highlighted, if not press [Tab→] key until it is.
7. Enter using numeric keys [4] [4].[.] [5] then softkey {GHz}. Note IF Frequency is blank, Sideband should be LSB, LO Control should be Off. If not use the [Tab→] key to highlight the parameter to change and then press the appropriate softkey.
8. Press key [Frequency/Points] then softkey {Start Freq} and enter [4] [.] [5] {GHz} then softkey {Stop Freq} and enter [1] [8] {GHz}.
9. Press softkey {More 1 of 2} then softkey {Points} and enter [2] [8] [Enter].

10. Press [System] then softkey {Alignment} then softkey {Alignmnt Mode} to Point.

**NOTE**

Alignment should be ON.

11. Press key [Averaging/Bandwidth] then softkey {Averages} and enter [3] [2] [Enter]. Press softkey {Averaging} to On.
12. Press [Calibrate] twice and wait for calibration to complete.

### Measurement Procedure

1. Connect the Down Converter as shown in [Figure 4-2](#) for measurement then press [Restart] and wait for the sweep to complete before reading off the results. Use the table format for the results and single sweep so the results can be easily read. For table format press [Format] then softkey {Format} then softkey {Table}.

Figure 4-2 N8975A Test Set-up for Measurement

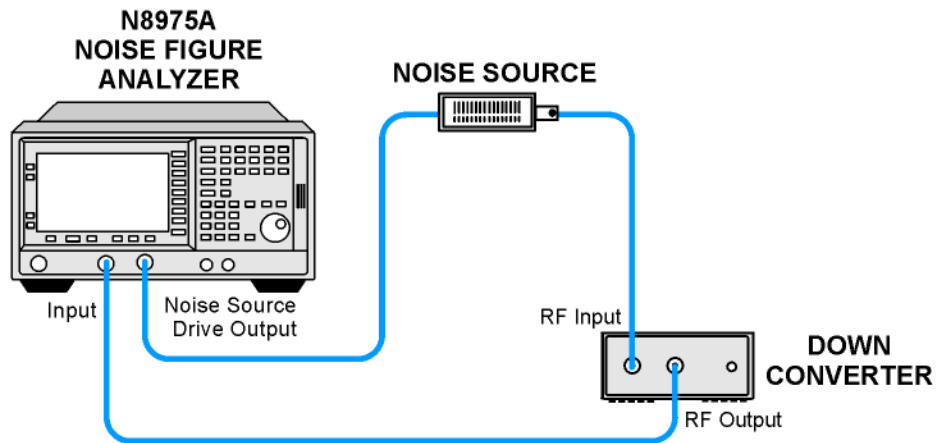

## Section 4.07 Frequency Range and Noise Figure (N8975B)

The Noise Figure Analyzer uses Measurement Mode DUT is Down Converter in fixed LO mode to measure the noise figure of the N8975A Option K40.

### Specification

Frequency Range	26.5 GHz to 40 GHz
Noise Figure	20 dB Maximum

### Equipment

Noise Figure Analyzer	N8975B
Noise Source	346C Option K01
Adapter APC 2.4mm female to APC 3.5mm female)	1250-2277

### Calibration Procedure

1. Connect the test equipment as shown in [Figure 4-3](#) for calibration.

**Figure 4-3** N8975B Test Set-up for Calibration

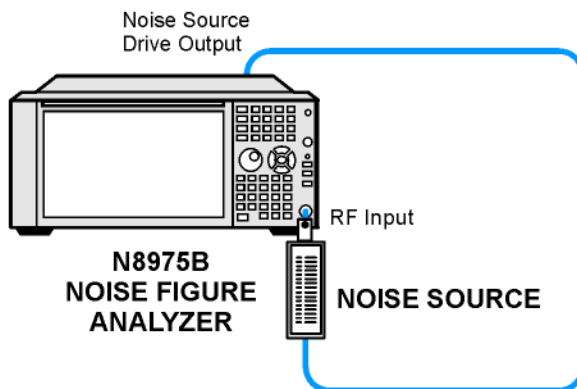

2. Switch on the N8975B and the K40 Down Converter and allow 30 minutes to warm up.
3. Preset all instruments, then enter the ENR data for the noise sources into the N8975B. See [Chapter 3](#) ENR Data for details. Only data from 4 to 18 GHz (from the 346CK01) and 26.5 to 40 GHz (from the high frequency noise source) is needed for the performance test.

4. Press the [Meas Setup] hardkey, then the {DUT Setup & Calibration} softkey.
5. Tap the DUT block and change the DUT from Amplifier to Downconv.
6. Set the remaining parameters as follows:
  - a. Sideband → USB
  - b. LO Mode → Fixed
  - c. Ext LO Control → Off
  - d. LO Power → 0.00 dBm
7. Tap the DUT LO block and using the numeric keypad enter 44.5 GHz.
8. Tap the DUT Output (IF) and enter a start frequency of 4.5 GHz and a stop frequency of 18 GHz.
9. Tap Int PA block and change the Points from 11 to 28 and select Enter.
10. Referring the figure below, verify all the parameters have been correctly set and then select Close on the DUT Setup & Calibration screen:

Figure 4-4

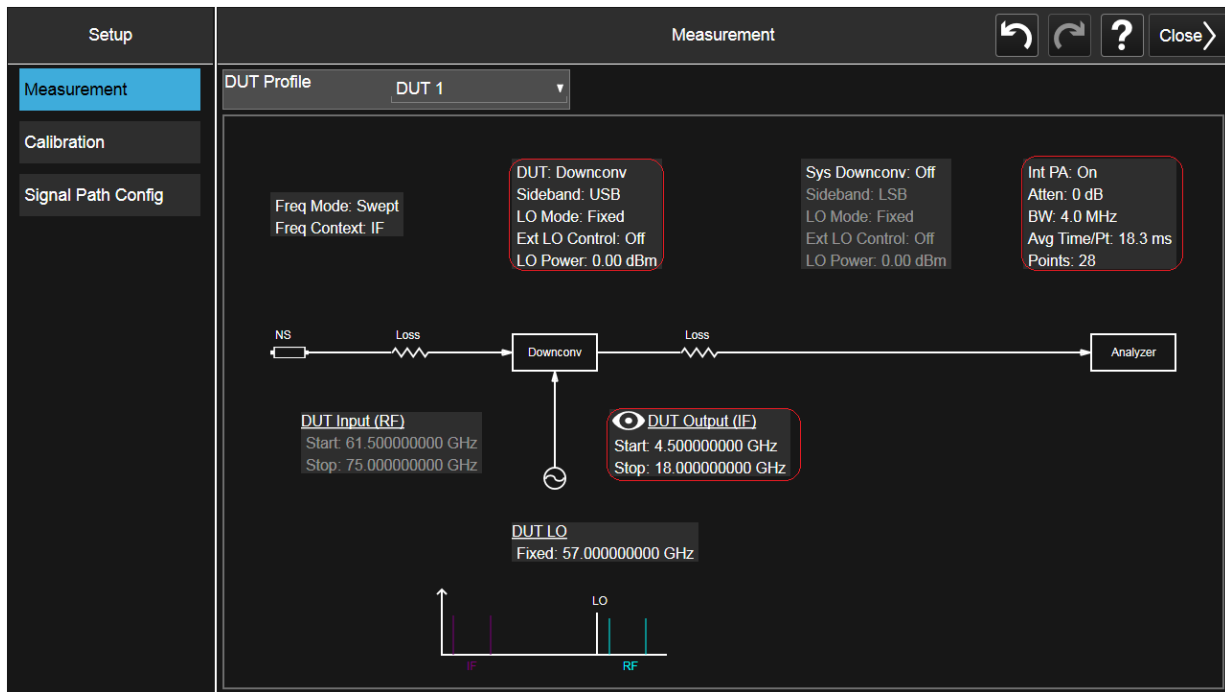

11. Press the Meas Setup hardkey and toggle the Averaging switch to On.
12. Tap Avg/Hold Num and change the number of averages from 10 to 32.
13. Press the {Calibrate} softkey, then select OK and wait for the calibration to complete.

## Measurement Procedure

1. Connect the Down Converter as shown in **Figure 4-5** for measurement then press [Restart] and wait for the sweep to complete before reading off the results. Use the table format for the results and single sweep so the results can be easily read. For table format press [Format] then softkey {Format} then softkey {Table}.

Figure 4-5 N8975B Test Set-up for Measurement

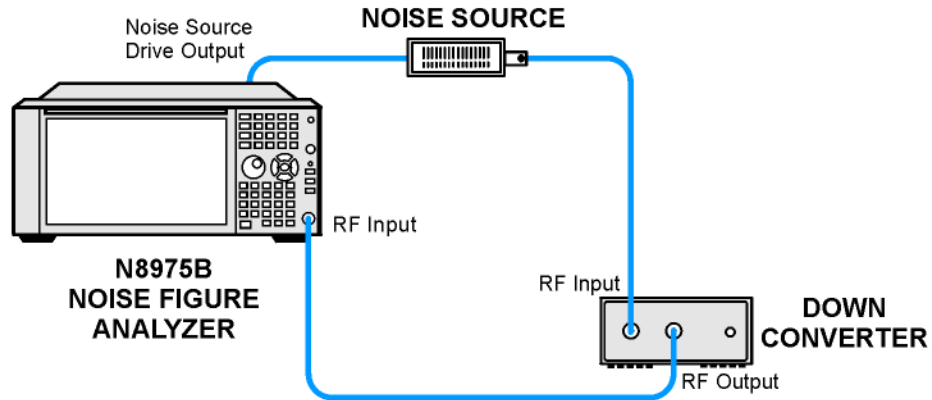

## Section 4.08 LO Frequency Accuracy

This test measures the Local Oscillator frequency by observing the output frequency at the RF OUTPUT when a highly stable and accurate 26500 MHz is input.

Specification

---

44.5 GHz  $\pm$  50 MHz

---

Equipment

---

Frequency Synthesizer	83640A
-----------------------	--------

---

Spectrum Analyzer	E4407B
-------------------	--------

---

Figure 4-6

Test Set-up for LO Accuracy and Troubleshooting

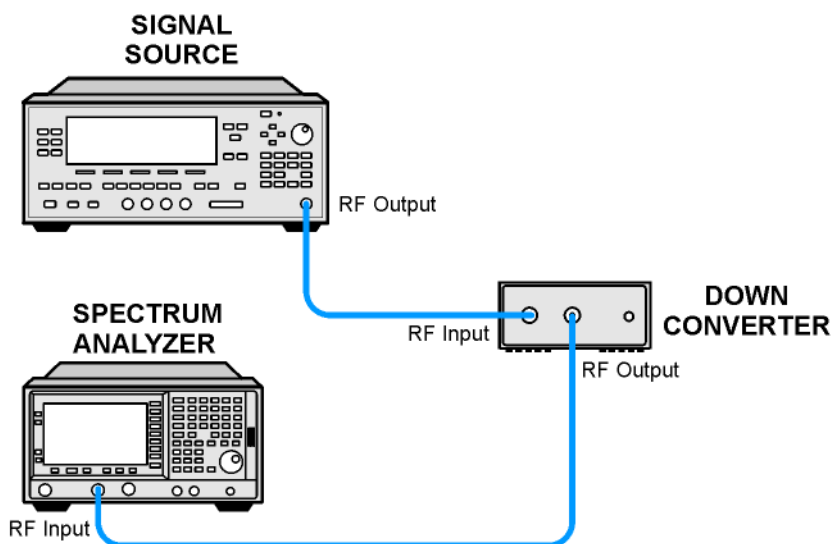



## LO Frequency Accuracy Measurement Procedure

1. Set the 83640A combination for a CW signal of 26500 MHz at -30dBm
2. Connect the equipment as shown in **Figure 4-6**. Connect the RF output of the 83640A to the N8975A Option K40 RF INPUT and connect the E4407B input to the N8975A Option K40 RF OUTPUT.
3. From E4407B, press [PRESET] on the Spectrum Analyzer then press [CENTER FREQ] [1] [8] [GHz], [FREQ SPAN] [1] [0] [0] [MHz]. An 18 GHz signal at about -30 dBm should be observed near the center of the display.
4. Press Spectrum Analyzer [Marker NORMAL] and [PEAK SEARCH]. Read the frequency in the upper right hand corner of the display. The indicated frequency should be 18000 MHz  $\pm$ 50. Record the frequency to the Test Record Card.

Table 4-1

Performance Test Record

Test		Results	
Noise Figure Vs. Frequency		Gain	Actual NF
Frequency (GHz)		(dB)	(dB)
IF	RF		Max NF
			(dB)
18.00	26.50		20.00
17.50	27.00		20.00
16.50	28.00		20.00
15.50	29.00		20.00
14.50	30.00		20.00
13.50	31.00		20.00
12.50	32.00		20.00
11.50	33.00		20.00
10.50	34.00		20.00
9.50	35.00		20.00
8.50	36.00		20.00
7.50	37.00		20.00
6.50	38.00		20.00
5.50	39.00		20.00
4.50	40.00		20.00
LO Frequency Accuracy		Min (MHz)	Actual
		17950	Max (MHz)
			18050

## 5 Adjustments

The N8975A Option K40 has no internal adjustments.

## Adjustments

## 6 Service

### Section 6.01 Introduction

This section contains information for troubleshooting and repairing the Down Converter. Included are block diagrams, schematic diagrams, principles of operation, and procedures for troubleshooting, repair, disassembly, and re-assembly.

### Section 6.02 Service Sheets

The pages following the service introduction are the service sheets comprising of block diagrams, schematics, supplemental diagrams, theory, and troubleshooting information.

### Section 6.03 Safety Considerations

The pages following the service introduction are the service sheets comprising of block diagrams, schematics, supplemental diagrams, theory, and troubleshooting information.

#### **a. Before Applying Power**

Verify that the instrument is set to match the available line voltage and that the correct fuse is installed. An uninterrupted safety earth ground must be provided from the main power source to the instrument input wiring terminals, power cable, or supplied power cable set.

#### **i. Warnings and Cautions**

Pay attention to WARNINGS and CAUTIONS. They must be followed for your protection and to avoid damage to the equipment.

### WARNING

Maintenance described herein is performed with power supplied to the instrument and with protective covers removed. Such maintenance should be performed only by service-trained personnel who are aware of the hazards involved (for example, fire and electrical shock). Where maintenance can be performed without power supplied, the power should be removed.

Any interruption of the protective (grounding) conductor (inside of outside the instrument) or disconnecting the protective earth terminal will cause a potential shock hazard that could result in personal injury. (Grounding one conductor of a two conductor outlet is not sufficient protection). In addition, verify that a common ground exists between the unit under test and this instrument prior to energizing either unit.

Whenever it is likely that the protection has been impaired, the instrument must be made inoperative and be secured against any unintended operation.

If this instrument is to be powered via an auto-transformer (for voltage reduction) make sure that the common terminal is connected to neutral (that is, the grounded side of the mains supply).

Servicing instructions are for use by service trained personnel only. To avoid dangerous electric shock, do not perform any servicing unless qualified to do so.

Adjustments described in the manual are performed with power supplied to the instrument while protective covers are removed. Energy available at many points may, if contacted, result in personal injury.

Capacitors inside the instrument may still be charged even if the instrument has been disconnected from its source of supply.

For continued protection against fire hazard, replace the line fuse(s) only with 250V fuse(s) of the same current rating and type (F3.15AH, 250V). Do not use repaired fuses or short circuited fuse holders.

### CAUTION

Do not disconnect or remove any carriers or boards in the instrument unless the instrument is unplugged. Some boards contain devices that can be damaged if the board is removed when the power is on.

## Section 6.04 Servicing the Instrument

Once an error has been detected, and the fault is known to be within the instrument, it is necessary to place the instrument in a serviceable position. refer to Top and Bottom Covers removal procedure near the end of this section.

## Section 6.05 Pozidrive Screwdrivers

Many screws in the Down Converter appear to be Phillips type, but are not. To avoid damage to the screw headshots, Pozidrive screwdrivers should be used. 8710-0899 is the number 1 Pozidrive. 8710-0900 is number 2 Pozidrive.

## Section 6.06 Hardware

The Down Converter has a mixture of unified national (inch) and metric screws. The metric screws are defined in Industrial Fasteners Publication (IFI 500) and are identified in the list as metric. The unified national screws are identified in the list as non-metric. To prevent thread damage, ensure that the same type of screw and nut is used in each application.

## Section 6.07 Assembly Locations

Assemblies in the Down Converter are numbered in groups, both by function and by location. Refer to the service sheets for identification of assemblies.

## Section 6.08 Parts and Cable Locations

The location of individual components mounted on the assemblies are shown near the schematic diagram. The part reference designator is the assembly designator plus the parts designator. For example, A2R9 is R9 on the A2 assembly. For specific component descriptions and ordering information, refer to [Table 8-1 on page 57](#), in Section 8-2.

## Section 6.09 Test Point Locations

There are no test point locations identified.

## Section 6.10 Cover Removal

### Cover Removal

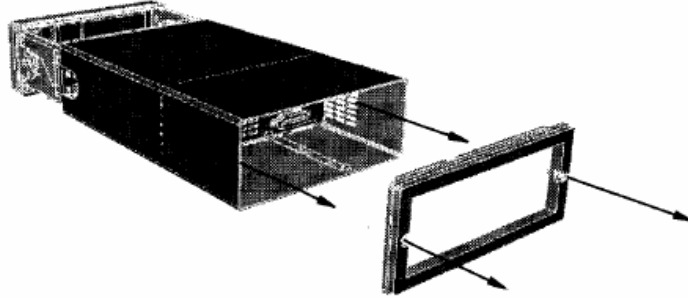

To remove the cover, remove the two screws that hold the rear bezel, as shown in the above picture.

When replacing the cover re-tighten the captive screws in the rear bezel using a 9 in-lbs T15 -screwdriver.

## Section 6.11 Cleaning Intervals

Keysight Technologies recommends a 12 month interval between cleaning for some parts of the Down Converter. Front panel connectors should be cleaned every 6 months. Cleaning intervals, are dependent upon where the Down Converter is used. It should be cleaned more frequently if the environment used is a dusty or very humid area.

## Section 6.12 Six Month Cleaning

Clean the cabinet of the instrument with a damp cloth only. Careful cleaning of front panel connectors is essential to assure long, reliable connector life, to prevent accidental damage to connectors, and to obtain maximum measurement accuracy and repeatability.

Dirt and stubborn contaminants should be removed with a cotton swab or lint-free cleaning cloth moistened with a solvent.

### NOTE

Use the least amount of solvent possible, and avoid wetting any plastic parts in the connectors with the solvent.

---

Use liquid solvents rather than spray. If a spray must be used, always spray the solvent onto a cloth or swab, never directly into a connector.



Very dirty connectors can be cleaned with 91% isopropyl alcohol, Part Number 8500-0559.

**WARNING**

**Do not use aromatic or chlorinated hydrocarbons, esters, trepans, higher alcohol's, keytones of ether-alcohols such as benzene toluene, turpentine, dioxin, gasoline, cellosolve acetate, or carbon tetrachloride.**

---

Whichever solvent is used, carefully avoid wetting the plastic support bead inside the connector and blow the connector dry immediately with a gently stream of compressed air. Support beads are easily damaged by solvents.

Interior surfaces, especially on precision 3.5 mm connectors, are very difficult to reach, and it is easy to damage connectors in trying to clean them. One suitable method is to cut off the sharp tip of a round wooden toothpick and then to wrap it with a single layer of lint-free cleaning cloth. (A round wooden toothpick or a very small diameter wooden rod is required: metal must never be used because it will scratch the plated surface; diameter must not exceed 0.070 in. or 1.7mm. Moisten the cloth with a small amount of cleaning solvent and carefully insert it into the connector to clean the interior surfaces. Use an illuminated magnifying glass or microscope to see clearly the areas you wish to clean. When you have cleaned a connector, always be sure that it is completely dry before using it. Blow the connector dry with a gently stream of clean compressed air and inspect it again under a magnifying glass to be sure that no particles or solvent residues remain.

## Section 6.13 Twelve Month Cleaning

**WARNING**

**Before cleaning, make sure the Down Converter is dis-connected from the power source. This is to eliminate the possibility of electrical shock.**

---

1. Remove the top and bottom covers to gain access to the interior of the instrument.
2. Using a brush, remove dirt from the fan guard and fan blades.
3. Using compressed air, remove dust and dirt from the area behind the fan. Blow air out through the fan and remove loose dirt.
4. Using air and/or a soft bristle brush, clean all other accessible areas of the instrument, starting from the top, including the A1, A2 and A3 assemblies.
5. Replace the instrument covers.

## Section 6.14 Overall Troubleshooting

The Overall Troubleshooting section consists of Principles of Operation and Troubleshooting information for the Down Converter.

## Section 6.15 Principles of Operation

Input frequencies from 26.5 to 40 GHz are coupled into the A2 Down Converter by coax to waveguide transition. A2FL1 prevents frequencies above and below the 26.5 GHz to 40 GHz band from entering the mixer A2U1. Frequencies above 40 GHz, in the image band (49–62.5 GHz), could mix with the 44.5 GHz LO and cause spurious outputs. Frequencies from 26.5 to 40 GHz will mix with this LO and create an Intermediate Frequency of 18 to 4.5 GHz which is amplified by A2AR1 and routed to the RF OUTPUT. Further IF filtering is performed with the input YIG filter in the N8975A/B. Note that the N8975A Option K40 uses a LO below the incoming RF so that increasing RF frequency results in increasing IF frequencies e.g. 26.5 GHz input corresponds to 18 GHz output.

## Section 6.16 Troubleshooting

This information is in the form of suggestions to allow the technician troubleshooting the Down Converter to isolate the problem area as rapidly as possible.

The information contained in the Block and Schematic Diagrams, should be used to isolate a malfunction.

Failures generally fall into two categories: catastrophic failures or performance degradation. In both cases it is important to first verify that the failure is in the Down Converter, and not the test equipment.

## Section 6.17 Check List

Make a visual inspection of the Down Converter and the connectors of any test instruments. Look for damage to the coax connectors and check that the internal fan is operating.

If the failure is catastrophic, check the +15 volt power supply.

If the LO frequency is incorrect A2A1 is faulty, replace A2 assembly.

If the problem is high noise figure, or low conversion gain, (but the LO frequency is correct), the problem is most likely a failed A2AR1 IF amplifier, or A2U1 mixer, or the input isolator, replace A2 assembly.

The IF amp has a gain of about 25 dB, and a noise figure of about 6 dB. The mixer has a conversion loss and noise figure of about 7 dB. If these components are OK, check that the LO is driving the L port of the mixer with about +12 dBm.

After completing any repairs to the Up/Down Converter, the tests in **Chapter 4, "Performance Tests", on page 33** should be performed to ensure that the instrument is operating within the specified limits.

**NOTE**

The complete A2 assembly should be returned to Keysight Technologies, if faulty. It will be repaired and re-aligned before returning to the customer.

Figure 6-1 Blockdown Converter

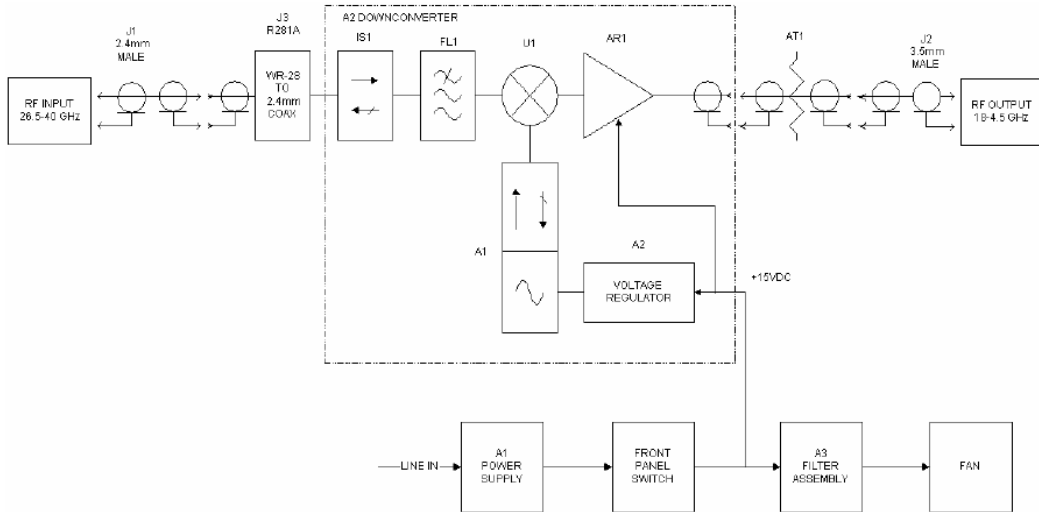

N8975A OPTION K40 BLOCK DOWNCONVERTER BLOCK DIAGRAM

Figure 6-2 Internal Assemblies Layout

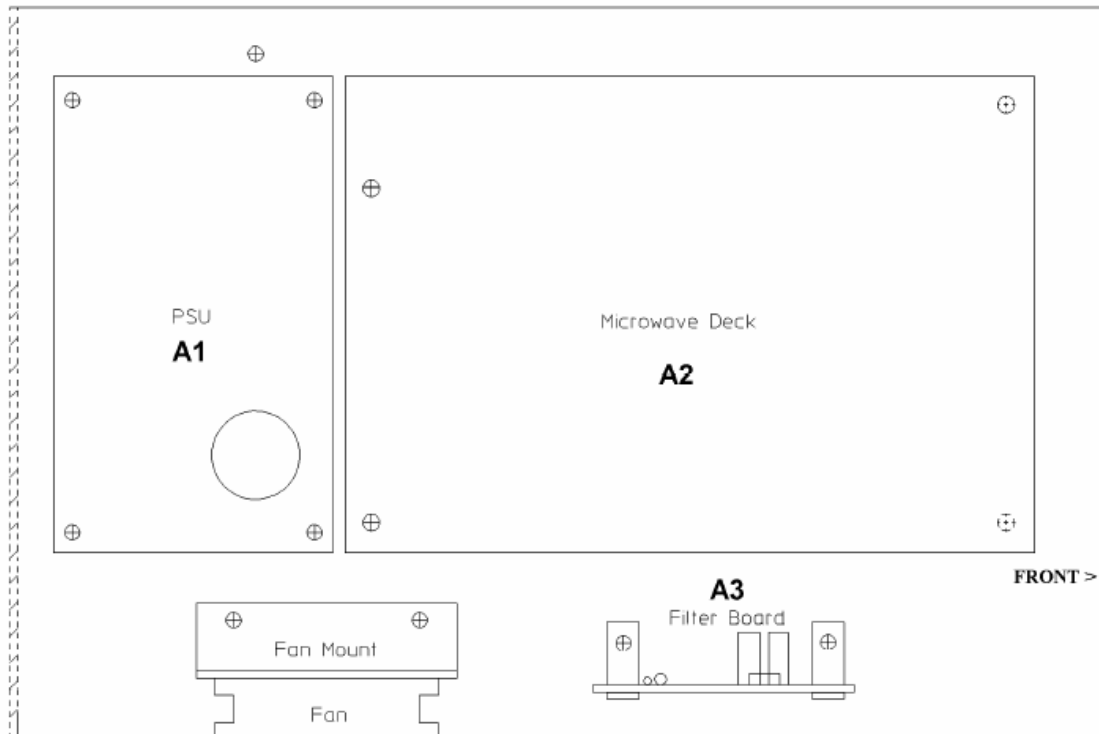

Figure 6-3 Layout of A2 Block Down Converter

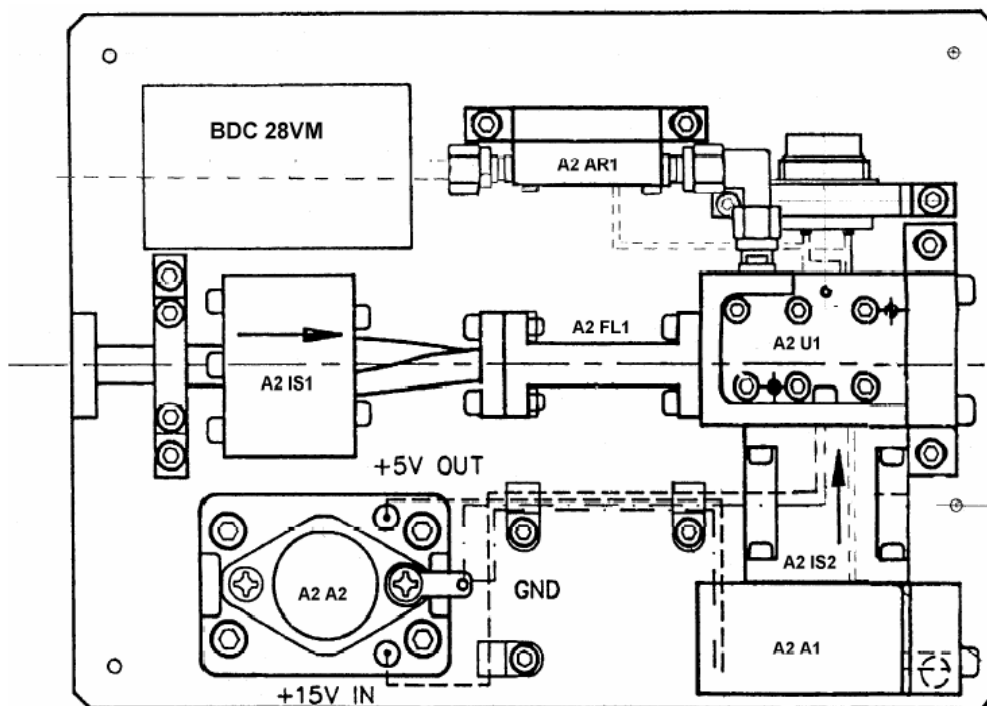
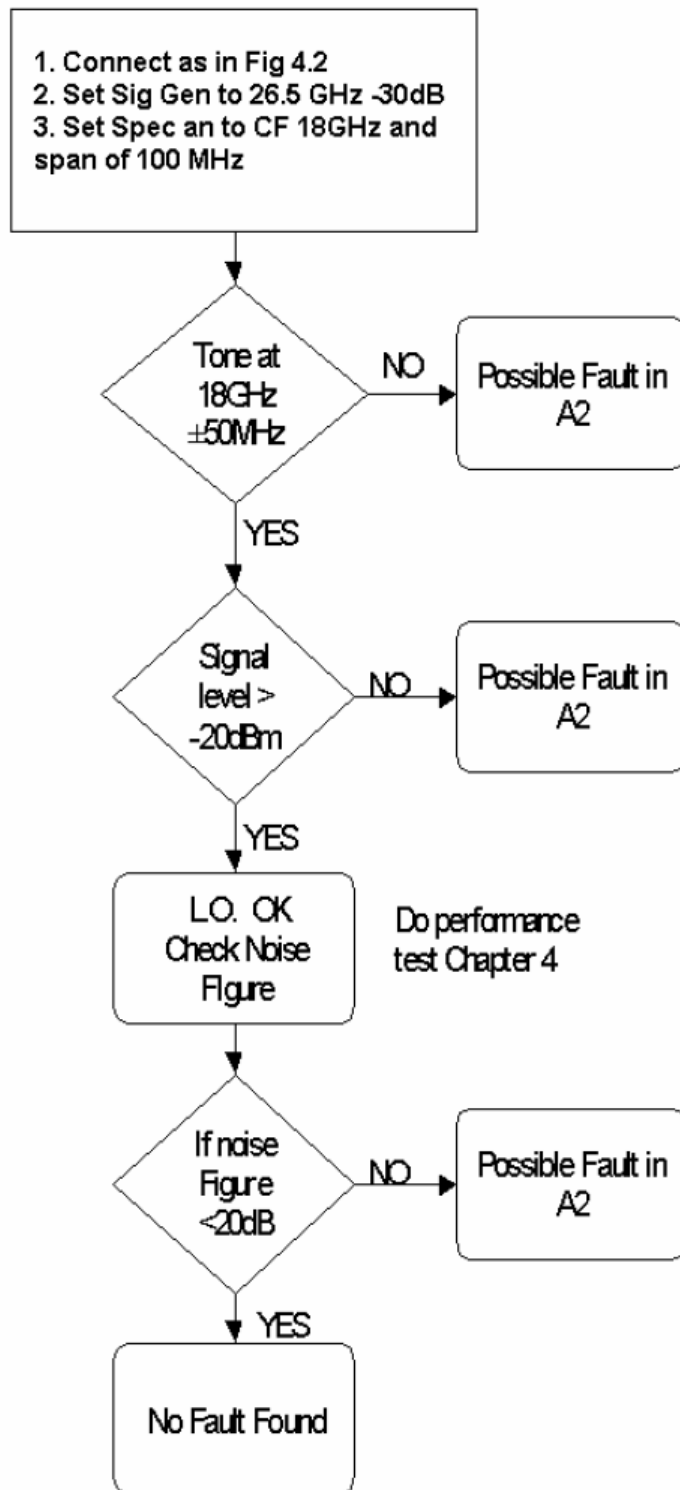

Figure 6-4 Troubleshooting Flow Diagram



Service  
Section 6.17 Check List

## 7 Operating the Down Converter with the 8970B/8971C NF System

To operate the Down Converter with the 8970S/V Noise Figure Measurement System set-up the 8970S/V as indicated in Section 3-13 of the 8970B Operating and Service Manual. Connect the N8975A Option K40 as shown in **Figure 7-1**.

Load the ENR data to cover the frequency range to be measured.

### i. Calibration and Measurement Procedure

As an example, the following procedure would be used to calibrate and measure the noise figure and gain of an amplifier from 26.5 to 40 GHz every 500 MHz.

1. Set up the measurement parameters with the following key strokes;
  - a. Press [0] [.] [9] [SPECIAL FUNCTION]. Press [0] [.] [9] [SPECIAL FUNCTION] (This initializes the special functions)
  - b. Press [1] [.] [7] [SPECIAL FUNCTION] (Sets up fixed LO variable IF operation).
  - c. Press [4] [1] [.] [n] [SPECIAL FUNCTION] (Where n selects the correct system local oscillator program).  
If a 8673x Synthesizer is used, Press [4] [1] [.] [3] [SPECIAL FUNCTION].
  - d. Press [2] [.] [1] [SPECIAL FUNCTION] (Sets up lower sideband operation).
  - e. Press [START FREQ] [2] [6] [5] [0] [0] [ENTER] (Start frequency 26.5 GHz). (Ignore error E28, since the system is not yet calibrated).
  - f. Press [STOP FREQ] [4] [0] [0] [0] [0] [ENTER] (Stop frequency 40 GHz).
  - g. Press [STEP SIZE] [5] [0] [0] [ENTER] (Frequency step 500 MHz).
  - h. Press [3] [.] [1] [SPECIAL FUNCTION] [4] [4] [5] [0] [0] [ENTER] (N8975A Option K40 internal LO is 44.5 GHz).

2. Calibrate the system by attaching the Noise Source to the N8975A Option K40 RF INPUT. When the Calibrate indicator goes out, and all bus activity has ceased, the system is calibrated.
3. Connect the device under test between the Noise Source and the N8975A Option K40 RF INPUT. Press [CORRECTED NOISE FIGURE AND GAIN]. The 8970B will display the measurement frequency, the gain and the noise figure of the amplifier at each selected frequency.

**NOTE**

For the Noise Figure Measurement System specifications to be valid, the measurement must use the same START FREQ, STOP FREQ and STEP SIZE that was used for calibration. None of the calibrated points can be skipped. Also, the measurement must be done in the same direction as the calibration, for example, from start frequency to stop frequency.

Figure 7-1 Test Setup for Calibration and Measurement with 8970B/71C

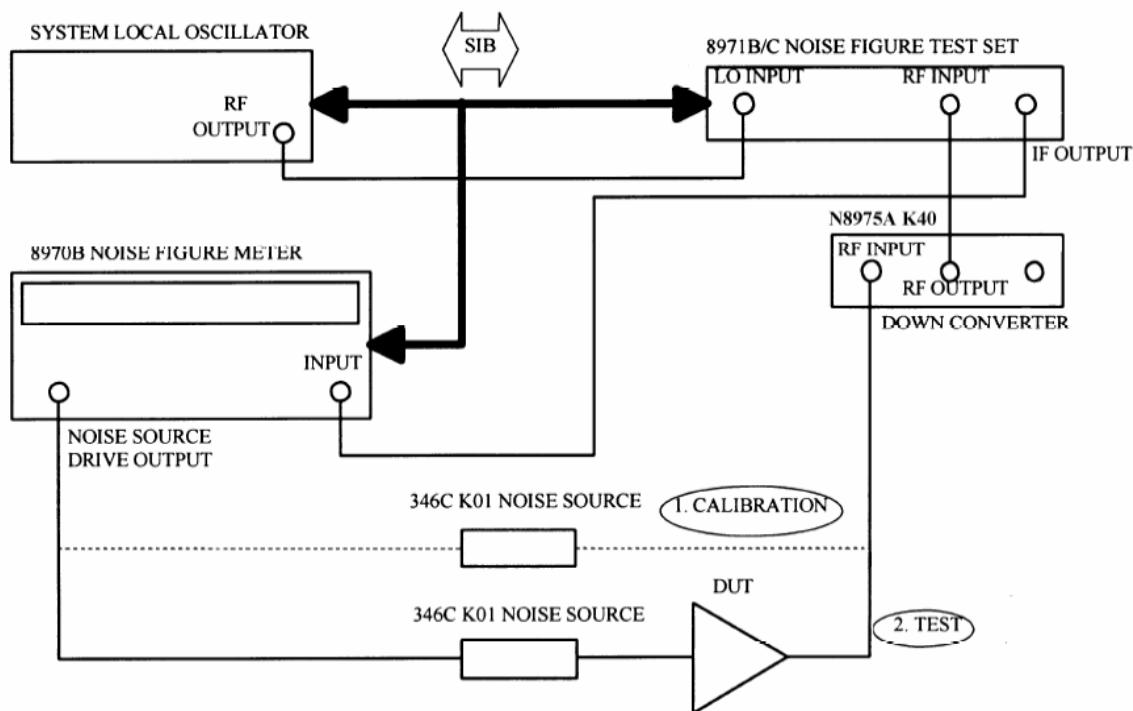



## 8 Service Replaceable Parts

### Section 8.01 Introduction

This section contains information for ordering parts. Table 8-1 lists all in reference designator order.

### Section 8.02 Accessories

Table 8-1

ITEM	PART NUMBER	QTY	DESCRIPTION	SUPPLIER
1	E4418-61025	1	CHASSIS	Keysight Technologies
2	N8975-40001	1	BEZEL	Keysight Technologies
3	N8975-00001	1	BASE PLATE	Keysight Technologies
4	N8975-00002	1	DC FILTER PLATE	Keysight Technologies
5	N8975-00008	1	FRONT PANEL	Keysight Technologies
6	N8975-80001	1	REAR PANEL	Keysight Technologies
7	N8975-00003	2	FAN MOUNTING PLATE	Keysight Technologies
8	N8975-61005	1	FAN 12VDC	Keysight Technologies
9	0380-4210	4	PSU/FILTER STANDOFFS	Keysight Technologies
10	N8975-61006	1	PSU	Keysight Technologies
11	5062-6615	1	CONN CX 2.4 RF INPUT	Keysight Technologies
12	2950-0132	1	NUT for RF INPUT	Keysight Technologies
13	5062-1247	1	CONN 3.5 IF OUTPUT	Keysight Technologies
14	2950-0132	1	NUT for above	Keysight Technologies
15	2190-0068	2	WASHER for above connectors	Keysight Technologies
16	N8975-00016	1	EMI SCRNM	Keysight Technologies
17	3101-2359	1	Panel push switch	Keysight Technologies
18	R281A-FG	1	ADAPTER	Keysight Technologies

Service Replaceable Parts  
Section 8.02 Accessories

Table 8-1

ITEM	PART NUMBER	QTY	DESCRIPTION	SUPPLIER
19	08970-60104	1	PCA Filter Assembly	Keysight Technologies
20	0515-0886	10	SCREW M3x6mm PAN	Keysight Technologies
21	0535-0025	4	NUT M3	Keysight Technologies
22	0515-1111	4	SCREW M3x16mm PAN	Keysight Technologies
23	0515-1232	2	SCREWS M3.5x8mm	Keysight Technologies
24	0535-0007	2	N U TS M3.5	Keysight Technologies
25	1251-0670	2	CRIMPS CONT-CONN F	Keysight Technologies
26	1251-2993	1	CONN SHELL POST .156	Keysight Technologies
27	0535-0023	6	NUT M4	Keysight Technologies
28	2190-0640	7	LOCK WASHERS M4	Keysight Technologies
29	1400-1552	4	ADHESIVE CABLE TIES	Keysight Technologies
30	E4418-61027	1	COVER	Keysight Technologies
31	34401-45011	1	HANDLE	Keysight Technologies
32	E4418-20008	1	REAR FRAME	Keysight Technologies
33	34401-86011	1	RUBBER BUMPER (FRONT)	Keysight Technologies
34	34401-86012	1	RUBBER BUMPER (REAR)	Keysight Technologies
35	8150-0449	1	RED WIRE	Keysight Technologies
36	8150-0456	1	BLUE WIRE	Keysight Technologies
37	8150-0452	1	GREEN WIRE	Keysight Technologies
38	N8975-20001	1	SEMI-RIGID CABLE I/P	Keysight Technologies
39	N8975-20002	1	SEMI-RIGID CABLE O/P	Keysight Technologies
40	0360-0016	1	TERMINAL SOLDER	Keysight Technologies
41	8150-0005	AR	BLACK WIRE	Keysight Technologies
42	N8975-60001	1	Block Down Converter	Keysight Technologies
43	0515-0433	4	SCREW M4x8mm PAN	Keysight Technologies

Table 8-2 Accessories

ITEM	PART NUMBER	QTY	DESCRIPTION	SUPPLIER
44	5063-9240	1	RACK ADAPTER KIT	Keysight Technologies
45	1250-2188	1	ADAPTER-COAX STR F-2.4 mm	Keysight Technologies
46	08971-60128	1	RF CABLE	Keysight Technologies



This information is subject to change without notice.

© Keysight Technologies 2007-2021

Edition 1, November 2021

N8975-90002

[www.keysight.com](http://www.keysight.com)