

Keysight 8494/95/96A/B Attenuators



Operating and
Service Manual

Notices

Copyright Notice

© Keysight Technologies 2011 - 2021
No part of this manual may be reproduced in any form or by any means (including electronic storage and retrieval or translation into a foreign language) without prior agreement and written consent from Keysight Technologies as governed by United States and international copyright laws.

Manual Part Number

08494-90008

Edition

Edition 7, November 12, 2021

Printed in:

Printed in Malaysia

Published by:

Keysight Technologies
Bayan Lepas Free Industrial Zone,
11900 Penang, Malaysia

Technology Licenses

The hardware and/or software described in this document are furnished under a license and may be used or copied only in accordance with the terms of such license.

Declaration of Conformity

Declarations of Conformity for this product and for other Keysight products may be downloaded from the Web. Go to <http://www.keysight.com/go/conformity>. You can then search by product number to find the latest Declaration of Conformity.

U.S. Government Rights

The Software is "commercial computer software," as defined by Federal Acquisition Regulation ("FAR") 2.101. Pursuant to FAR 12.212 and 27.405-3 and Department of Defense FAR Supplement ("DFARS") 227.7202, the U.S. government acquires commercial computer software under the same terms by which the software is customarily provided to the public. Accordingly, Keysight provides the Software to U.S. government customers under its standard commercial license, which is embodied in its End User License Agreement (EULA), a copy of which can be found at <http://www.keysight.com/find/sweula>. The license set forth in the EULA represents the exclusive authority by which the U.S. government may use, modify, distribute, or disclose the Software. The EULA and the license set forth therein, does not require or permit, among other things, that Keysight: (1) Furnish technical information related to commercial computer software or commercial computer software documentation that is not customarily provided to the public; or (2) Relinquish to, or otherwise provide, the government rights in excess of these rights customarily provided to the public to use, modify, reproduce, release, perform, display, or disclose commercial computer software or commercial computer software documentation. No additional government requirements beyond those set forth in the EULA shall apply, except to the extent that those terms, rights, or licenses are explicitly required from all providers of commercial computer software pursuant to the FAR and the DFARS and are set forth specifically in writing elsewhere in the EULA. Keysight shall be under no obligation to update, revise or otherwise modify the Software. With respect to any technical data as defined by FAR 2.101, pursuant to FAR 12.211 and 27.404.2 and DFARS 227.7102, the U.S. government acquires no greater than Limited Rights as defined in FAR 27.401 or DFAR 227.7103-5 (c), as applicable in any technical data.

Warranty

THE MATERIAL CONTAINED IN THIS DOCUMENT IS PROVIDED "AS IS," AND IS SUBJECT TO BEING CHANGED, WITHOUT NOTICE, IN FUTURE EDITIONS. FURTHER, TO THE MAXIMUM EXTENT PERMITTED BY APPLICABLE LAW, KEYSIGHT DISCLAIMS ALL WARRANTIES, EITHER EXPRESS OR IMPLIED, WITH REGARD TO THIS MANUAL AND ANY INFORMATION CONTAINED HEREIN, INCLUDING BUT NOT LIMITED TO THE IMPLIED WARRANTIES OF MERCHANTABILITY AND FITNESS FOR A PARTICULAR PURPOSE. KEYSIGHT SHALL NOT BE LIABLE FOR ERRORS OR FOR INCIDENTAL OR CONSEQUENTIAL DAMAGES IN CONNECTION WITH THE FURNISHING, USE, OR PERFORMANCE OF THIS DOCUMENT OR FOR ANY INFORMATION CONTAINED HEREIN. SHOULD KEYSIGHT AND THE USER HAVE A SEPARATE WRITTEN AGREEMENT WITH WARRANTY TERMS COVERING THE MATERIAL IN THIS DOCUMENT THAT CONFLICT WITH THESE TERMS, THE WARRANTY TERMS IN THE SEPARATE AGREEMENT SHALL CONTROL.

Safety Information

CAUTION

A CAUTION notice denotes a hazard. It calls attention to an operating procedure, practice, or the like that, if not correctly performed or adhered to, could result in damage to the product or loss of important data. Do not proceed beyond a CAUTION notice until the indicated conditions are fully understood and met.

WARNING

A WARNING notice denotes a hazard. It calls attention to an operating procedure, practice, or the like that, if not correctly performed or adhered to, could result in personal injury or death. Do not proceed beyond a WARNING notice until the indicated conditions are fully understood and met.

Environmental Conditions

The table below shows the general environmental requirements for this instrument.

Environmental condition	Requirement
Temperature	Operating condition: – 0 °C to +55 °C Storage condition: – –40 °C to +75 °C
Humidity	<95% relative
Altitude	Operating condition: – <4600 m (15000 ft) Storage condition: – <7600 m (25000 ft)
Shock	Operating condition: – 10 Gs, 6 ms, on six sides, three blows Non-operating condition: – 500 Gs, 1.8 ms, in six directions
Vibration	5 Gs, 34 Hz to 2000 Hz
EMC	Radiated interference is within the requirements of MIL-STD-461, RE02

Regulatory Markings

 <p>This symbol indicates the time period during which no hazardous or toxic substance elements are expected to leak or deteriorate during normal use. Forty years is the expected useful life of the product.</p>	 <p>This instrument complies with the WEEE Directive (2002/96/EC) marking requirement. This affixed product label indicates that you must not discard this electrical or electronic product in domestic household waste.</p>
---	---

Waste Electrical and Electronic Equipment (WEEE) Directive 2002/96/EC

This instrument complies with the WEEE Directive (2002/96/EC) marking requirement. This affixed product label indicates that you must not discard this electrical or electronic product in domestic household waste.

Product category

With reference to the equipment types in the WEEE directive Annex 1, this instrument is classified as a "Monitoring and Control Instrument" product.

The affixed product label is as shown below.



Do not dispose in domestic household waste.

To return this unwanted instrument, contact your nearest Keysight Service Center, or visit <http://about.keysight.com/en/companyinfo/environment/takeback.shtml> for more information.

Sales and Technical Support

To contact Keysight for sales and technical support, refer to the support links on the following Keysight websites:

- www.keysight.com/find/mta
(product-specific information and support, software and documentation updates)
- www.keysight.com/find/assist
(worldwide contact information for repair and service)

THIS PAGE HAS BEEN INTENTIONALLY LEFT BLANK.

Table of Contents

Environmental Conditions	3
Regulatory Markings	4
Waste Electrical and Electronic Equipment (WEEE) Directive 2002/96/ EC	5
Product category	5
Sales and Technical Support	5
1 Introduction	
Product Overview	14
2 Installation	
Initial Inspection	16
Instrument Options	17
Mating Connectors	17
Installation Instructions	18
3 Specifications	
Specifications	20
Frequency range and attenuation	20
Attenuation accuracy	20
Maximum SWR	21
Maximum residual attenuation	21
Attenuation repeatability	21
RF power handling capability	22
Operating life	22
Physical specifications	22
4 Operating Guide	
Operating Instructions	26
Operator's check	27
Performance Tests	29

Service Instructions	29
Adjustment	29
Repair	29
Maintenance	29

List of Figures

Figure 3-1	Dimensions of Keysight 8494/95/96A/B Attenuators	.23
Figure 4-1	Operator's check setup27

THIS PAGE HAS BEEN INTENTIONALLY LEFT BLANK.

List of Tables

Table 2-1	Instrument options	17
Table 3-1	Frequency range and attenuation	20
Table 3-2	Attenuation accuracy	20
Table 3-3	Maximum SWR	21
Table 3-4	Maximum residual attenuation	21
Table 3-5	Physical specifications	22
Table 4-1	Attenuator switching order	26
Table 4-2	Attenuator and SWR settings	28

THIS PAGE HAS BEEN INTENTIONALLY LEFT BLANK.

1 Introduction

Product Overview 14

This chapter provides an overview of the Keysight 8494/95/96A/B Attenuators.

Product Overview

The Keysight 8494A/B, 8495A/B, and 8496A/B are 50- Ω coaxial step attenuators.

For the 8494A/B, the attenuation can be varied in 1 dB steps, or 10 dB steps for the 8495A/B and 8496A/B. The attenuation shown on the control knob is the additional attenuation added in the signal path over the insertion loss of the attenuator in the 0 dB position.

- The Keysight 8494A/B instruments are four-section attenuators with a range of 0 dB to 11 dB in 1 dB steps.
- The 8495A/B is a three-section attenuator with a range of 0 dB to 70 dB in 10 dB steps.
- The 8496A/B is a four-section attenuator with a range of 0 dB to 110 dB in 10 dB steps.

The attenuator sections are connected in cascade. Each section consists of a precision, thin-film attenuator card, a lossless thru-line, and a ganged pair of edge-line transmission lines. The edge-lines are flexed to make contact with either the attenuator card or the thru-line. The edge-line contacts are gold-plated leaf springs which ensure long life and high repeatability. Low-torque cams flex the edge lines. [Table 4-1](#) shows the switching arrangements.

CAUTION

Do not exceed the RF power rating of 1 W average or 100 W peak with a maximum pulse width of 10 μ s. Do not connect an attenuator RF input or output connector to greater than ± 7 Vdc. If the attenuator must be connected to a device with a potential greater than ± 7 Vdc, use a blocking capacitor.

2 Installation

Initial Inspection	16
Instrument Options	17
Mating Connectors	17
Installation Instructions	18

This chapter provides you important information on how to check and prepare your instrument for operation.

Initial Inspection

- 1 Unpack and inspect the shipping container and its contents thoroughly to ensure that nothing was damaged during shipment. If the shipping container or cushioning material is damaged, the contents should be checked both mechanically and electrically.
 - Check for mechanical damage such as scratches or dents.
 - Procedures for checking electrical performance are given under “**Operator’s check**” on page 27.
- 2 If the contents are damaged or defective, contact your nearest Keysight Technologies Service and Support Office. Refer to “**Sales and Technical Support**” on page 5 of this manual. Keysight Technologies will arrange for repair or replacement of the damaged or defective equipment. Keep the shipping materials for the carrier’s inspection.
- 3 If you are returning the instrument under warranty or for service, repackaging the instrument requires original shipping containers and material or their equivalents. Keysight Technologies can provide packaging materials identical to the original materials. Refer to “**Sales and Technical Support**” on page 5 of this manual for the Keysight Technologies nearest to you. Attach a tag indicating the type of service required, return address, model number, and serial number. Mark the container **FRAGILE** to insure careful handling. In any correspondence, refer to the instrument by model number and serial number.

Instrument Options

Each instrument is specified with an option number which denotes the configuration of the input and output connectors.

Table 2-1 Instrument options

Option	Connector description
001	Both connectors Type-N female
002	Both connectors SMA female
003 ^[a]	Both connectors APC-7

[a] Option 003 is not available with the 8494A, 8495A, and 8496A.

Mating Connectors

Mating RF connectors used with the Option 001 must be Type-N male connectors, which comply with U.S. military standard MIL-C-39012.

For Option 002, male SMA connectors must be used.

For Option 003, APC- 7 mating connectors must be used.

CAUTION

When installing the instrument, make sure that the connectors do not support weight or bear torque. The preferred procedure is to set up all equipment in position before connecting the instrument. Either connector may be used as the input or output connector.

Installation Instructions

The attenuators may be installed with or without the base. The base is removed by unscrewing the two fillister head screws from the bottom of the base. The attenuator may be mounted without the base by inserting two 4-40 screws into the screw holes in the bottom of the attenuator. Removing the base and mounting the attenuator does not affect the performance of the attenuator.

3 Specifications

Specifications 20

This chapter provides the specifications of the 8494/95/96A/B attenuators.

Specifications

Frequency range and attenuation

Table 3-1 Frequency range and attenuation

Specification	8494A	8494B	8495A	8495B	8496A	8496B
Frequency range	DC to 4 GHz	DC to 18 GHz	DC to 4 GHz	DC to 18 GHz	DC to 4 GHz	DC to 18 GHz
Attenuation	0 dB to 11 dB	0 dB to 11 dB	0 dB to 70 dB	0 dB to 70 dB	0 dB to 110 dB	0 dB to 110 dB
Step	1 dB	1 dB	10 dB	10 dB	10 dB	10 dB

Attenuation accuracy

(±dB): (Referenced from 0 dB)

Table 3-2 Attenuation accuracy

8494A/B	8495A/B 8496A/B	8494A		8494B			8495A			8495B			8496A			8496B		
		Attenuation selection (dB)	DC to 4 GHz	DC to 12.4 GHz	DC to 12.4 GHz	DC to 18 GHz	DC to 12.4 GHz	DC to 18 GHz	DC to 4 GHz	DC to 12.4 GHz	DC to 18 GHz	DC to 4 GHz	DC to 12.4 GHz	DC to 18 GHz	DC to 4 GHz	DC to 12.4 GHz	DC to 18 GHz	
1	10	0.2	0.3	0.7	0.2	0.5	0.6	0.2	0.5	0.6	0.2	0.5	0.6	0.2	0.5	0.6		
2	20	0.2	0.3	0.7	0.4	0.7	0.8	0.4	0.7	0.8	0.4	0.7	0.8	0.4	0.7	0.8		
3	30	0.3	0.4	0.7	0.5	0.9	1.2	0.5	0.9	1.2	0.5	0.9	1.2	0.5	0.9	1.2		
4	40	0.3	0.4	0.7	0.7	1.2	1.6	0.7	1.2	1.6	0.7	1.2	1.6	0.7	1.2	1.6		
5	50	0.3	0.5	0.7	0.8	1.5	2.0	0.8	1.5	2.0	0.8	1.5	2.0	0.8	1.5	2.0		
6	60	0.3	0.5	0.8	1.0	1.8	2.4	1.0	1.8	2.4	1.0	1.8	2.4	1.0	1.8	2.4		
7	70	0.4	0.6	0.8	1.2	2.1	2.8	1.2	2.1	2.8	1.2	2.1	2.8	1.2	2.1	2.8		
8	80	0.4	0.6	0.8	–	–	–	1.3	2.4	3.2	1.3	2.4	3.2	1.3	2.4	3.2		
9	90	0.4	0.6	0.8	–	–	–	1.5	2.7	3.6	1.5	2.7	3.6	1.5	2.7	3.6		
10	100	0.4	0.6	0.9	–	–	–	1.6	3.0	4.0	1.6	3.0	4.0	1.6	3.0	4.0		
11	110	0.5	0.7	0.9	–	–	–	1.8	3.3	4.4	1.8	3.3	4.4	1.8	3.3	4.4		

Maximum SWR

Table 3-3 Maximum SWR

Instrument	Frequency range (GHz)	Maximum SWR
8495A	DC to 4	1.35
8495B	DC to 8	1.35
	8 to 12.4	1.5
	12.4 to 18	1.7
8494A, 8496A	DC to 4	1.5
8494B, 8496B	DC to 8	1.5
	8 to 12.4	1.6
	12.4 to 18	1.9

Maximum residual attenuation

Table 3-4 Maximum residual attenuation

Instrument	Maximum residual attenuation
8494A, 8494B	0.6 dB + 0.09 dB/GHz
8495A, 8495B	0.4 dB + 0.07 dB/GHz
8496A, 8496B	0.6 dB + 0.09 dB/GHz

Attenuation repeatability

± 0.03 dB, typical (5 million cycles per section).

3 Specifications

RF power handling capability

1 W average, 100 W peak with maximum pulse width of 10 microseconds (all models).

Operating life

5 million cycles per section.

Physical specifications

Table 3-5 Physical specifications

Instrument	Dimensions ^[a]	Weight ^[b]
8494A/B	Per Figure 3-1	15 oz (425 g)
8495A/B	Per Figure 3-1	11 oz (312 g)
8496A/B	Per Figure 3-1	15 oz (425 g)

[a] Dimensions are for general information only. If dimensions are required for building special enclosures, contact your Keysight field engineer.

[b] Weight and width of the instrument vary with the option selected due to the type of connectors.

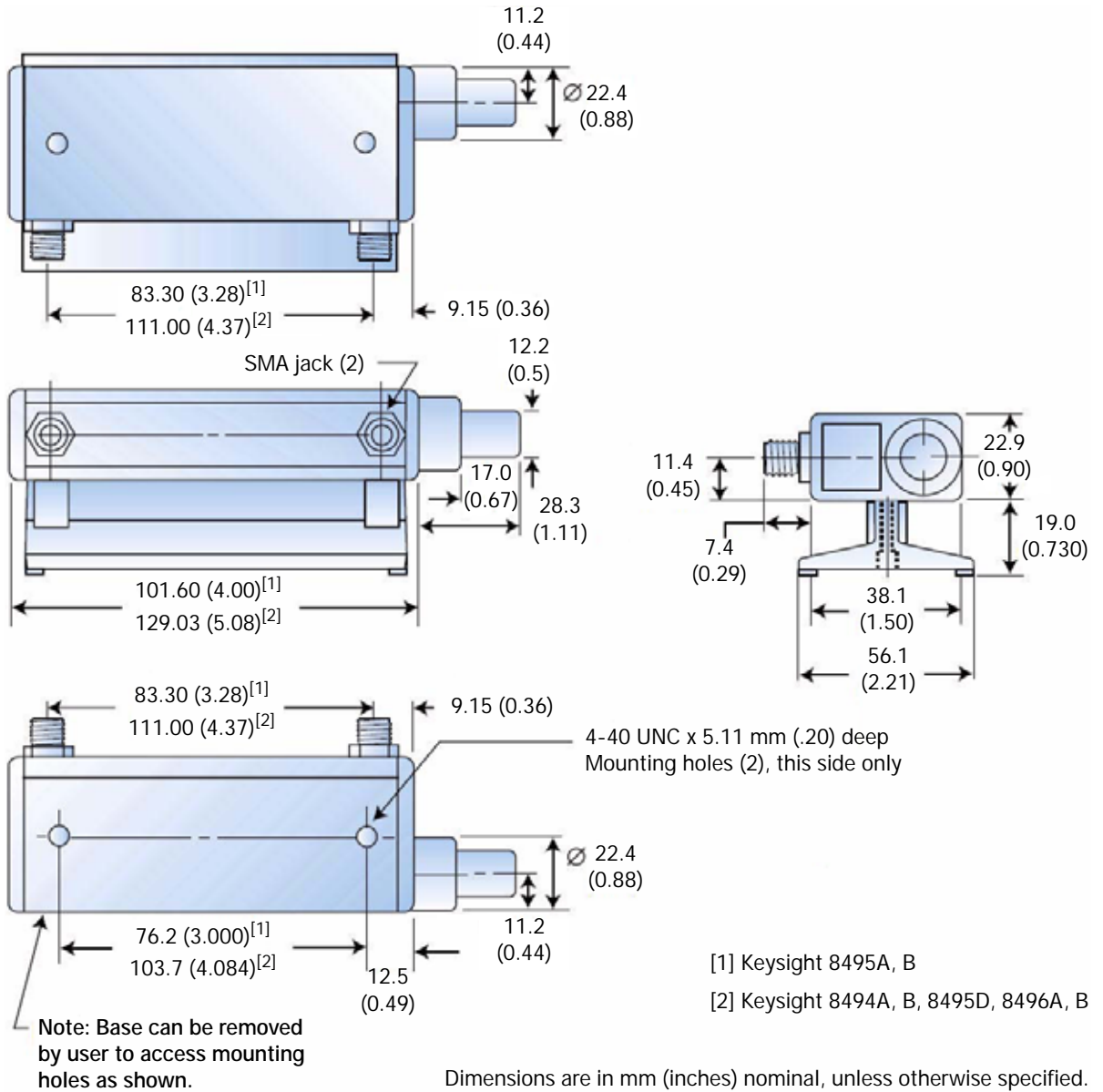

Figure 3-1 Dimensions of Keysight 8494/95/96A/B Attenuators

THIS PAGE HAS BEEN INTENTIONALLY LEFT BLANK.

4 Operating Guide

Operating Instructions	26
Performance Tests	29
Service Instructions	29

This chapter provides simple quick-check instructions to verify the attenuators' functionality prior to usage. It also provides information on service and maintenance of the attenuators.

Operating Instructions

CAUTION

Do not apply RF power greater than 1 W average, or 100 W peak with a maximum pulse width of 10 microseconds. If these limits are exceeded, the attenuators may be damaged.

After the instrument is connected, the attenuation may be selected. Turn counterclockwise to increase attenuation or clockwise to decrease attenuation. Either connector may be used as the input or output. [Table 4-1](#) lists the attenuator switching order.

Table 4-1 Attenuator switching order

8494A/B attenuator sections					8495A/B attenuator sections				8496A/B attenuator sections					
Atten (dB)	1 dB	2 dB	3 dB	4 dB	Atten (dB)	10 dB	20 dB	30 dB	40 dB	Atten (dB)	10 dB	20 dB	30 dB	40 dB
0					0					0				
1	x				10	x				10	x			
2		x			20		x			20		x		
3	x	x			30	x	x			30	x	x		
4				x	40			x		40				x
5	x		x		50	x		x		50	x		x	
6		x	x		60		x	x		60		x	x	
7	x	x	x		70	x	x	x		70	x	x	x	
8			x	x						80			x	x
9	x		x	x						90	x		x	x
10		x	x	x						100		x	x	x
11	x	x	x	x						110	x	x	x	x

CAUTION

Do not attempt to force the switch between 0 and the highest value position as there is a stop between these switch positions.

Operator's check

The operator's check allows the operator to make a quick check of the instrument prior to use or if a failure is suspected.

Description

The attenuator is driven from a 50- Ω signal source at 1 kHz. The output level from the attenuator is detected by a narrow-bandwidth voltmeter. The attenuator and detector range switches are stepped together and the variations in level noted. This verifies that each attenuator section is being properly switched and checks the low-frequency accuracy of the attenuator.

NOTE

The SWR meter used in this check is calibrated for a square-law detector. Therefore, the range changes and errors (read in dB) are twice that indicated by the meter.

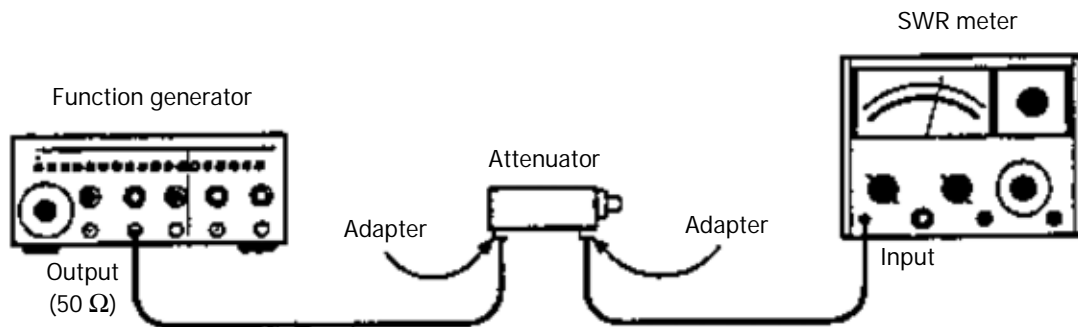

Figure 4-1 Operator's check setup

Procedure

- 1 Connect equipment as shown in [Figure 4-1](#) with the attenuator set to 0 dB attenuation.
- 2 Set the test oscillator to 0.3 Vrms at 1 kHz.
- 3 Set the SWR meter range to 2 dB (expanded) [or for the 8494A/B to 10 dB (expanded)] and adjust its bandwidth to the center of the adjustment range. Fine-tune the oscillator frequency to obtain maximum meter indication.
- 4 Set the attenuator and the SWR meter range switch as listed in [Table 4-2](#) and verify that the SWR meter indicates within the limits shown.

Table 4-2 Attenuator and SWR settings

SWR meter range (dB)		Attenuation (dB)			Meter indication (dB)					
					Minimum		Actual		Maximum	
8494A/B	8495A/B 8496A/B	8494A/B	8495A/B	8496A/B	8494A/B	8495A/B 8496A/B	8494A/B	8495A/B 8496A/B	8494A/B	8495A/B 8496A/B
10	2	0	0	0	–	–	Set to 0.0	Set to 0.5	–	–
10	6	1	10	10	0.40	1.40	–	–	0.60	1.60
10	12	2	20	20	0.90	0.30	–	–	1.10	0.70
10	16	3	30	30	1.35	1.25	–	–	1.65	1.75
10 ^[a]	22	4	40	40	1.85	0.15	–	–	2.15	0.85
12	26	5	50	50	0.35	1.10	–	–	0.65	1.90
12	32	6	60	60	0.85	0.00	–	–	1.15	1.00
12	36 ^[a]	7	70	70	1.30	0.90	–	–	1.70	2.10
12 ^[a]	42 ^[a]	8	–	80	1.80	–0.15	–	–	2.20	1.15
14	46 ^[a]	9	–	90	0.30	0.75	–	–	0.70	2.25
14	52 ^[a]	10	–	100	0.80	–0.30	–	–	1.20	1.30
14	56 ^[a]	11	–	110	1.75	0.60	–	–	1.75	2.40

[a] Adjust range by 2 dB, if needed, to obtain an on-scale indication.

Performance Tests

The Keysight 8494/95/96A/B Attenuators can be tested to the accuracy of the specifications with a network analyzer or equivalent equipment of suitable accuracy. If a network analyzer is available, test instrument using the procedure in the analyzer's operating manual.

Service Instructions

Adjustment

The Keysight 8494/95/96A/B Attenuators do not have internal adjustments and should not be opened.

Repair

The Keysight 8494/95/96A/B Attenuators are not recommended for repair as most components are not easily removed.

Maintenance

The connectors, particularly the connector faces, must be kept clean. For instruction on connecting and care of your connectors, refer to the *Microwave Connector Care Quick Reference Card (08510-90360)*.

THIS PAGE HAS BEEN INTENTIONALLY LEFT BLANK.



This information is subject to change without notice. Always refer to the English version at the Keysight website for the latest revision.

© Keysight Technologies 2011 - 2021
Edition 7, November 12, 2021

Printed in Malaysia



08494-90008

www.keysight.com