

Keysight 81610A/11A/12A/ 13A/14A Return Loss Module

NOTICE: This document contains references to Agilent Technologies. Agilent's former Test and Measurement business has become Keysight Technologies. For more information, go to www.keysight.com.



Notices

This document contains proprietary information that is protected by copyright. All rights are reserved.

No part of this document may be reproduced in (including electronic storage and retrieval or translation into a foreign language) without prior agreement and written consent from Keysight Technologies Deutschland GmbH as governed by United States and international copyright laws.

© Copyright 2000, 2015 by:
Keysight Technologies Deutschland GmbH
Herrenberger Str. 130
71034 Böblingen
Germany

Subject Matter

The material in this document is subject to change without notice.

Keysight Technologies *makes no warranty of any kind with regard to this printed material, including, but not limited to, the implied warranties of merchantability and fitness for a particular purpose.*

Keysight Technologies shall not be liable for errors contained herein or for incidental or consequential damages in connection with the furnishing, performance, or use of this material.

Printing History

New editions are complete revisions of the guide reflecting alterations in the functionality of the instrument. Updates are occasionally made to the guide between editions. The date on the title page changes when an updated guide is published. To find out the current revision of the guide, or to purchase an updated guide, contact your Keysight Technologies representative.

Control Serial Number: First Edition applies directly to all instruments.

Warranty

This Keysight Technologies instrument product is warranted against defects in material and workmanship for a period of one year from date of shipment. During the warranty period, Keysight will, at its option, either repair or replace products that prove to be defective.

For warranty service or repair, this product must be returned to a service facility designated by Keysight. Buyer shall prepay shipping charges to Keysight and Keysight shall pay shipping charges to return the product to Buyer. However, Buyer shall pay all shipping charges, duties, and taxes for products returned to Keysight from another country.

Keysight warrants that its software and firmware designated by Keysight for use with an instrument will execute its programming instructions when properly installed on that instrument. Keysight does not warrant that the operation of the instrument, software, or firmware will be uninterrupted or error free.

Limitation of Warranty

The foregoing warranty shall not apply to defects resulting from improper or inadequate maintenance by Buyer, Buyer-supplied software or interfacing, unauthorized modification or misuse, operation outside of the environmental specifications for the product, or improper site preparation or maintenance.

No other warranty is expressed or implied. Keysight Technologies specifically disclaims the implied warranties of Merchantability and Fitness for a Particular Purpose.

Exclusive Remedies

The remedies provided herein are Buyer's sole and exclusive remedies. Keysight Technologies shall not be liable for any direct, indirect, special, incidental, or consequential damages whether based on contract, tort, or any other legal theory.

Assistance

Product maintenance agreements and other customer assistance agreements are available for Keysight Technologies products. For any assistance contact your nearest Keysight Technologies Sales and Service Office.

Certification

Keysight Technologies certifies that this product met its published specifications at the time of shipment from the factory.

Keysight Technologies further certifies that its calibration measurements are traceable to the United States National Institute of Standards and Technology, NIST (formerly the United States National Bureau of Standards, NBS) to the extent allowed by the Institutes's calibration facility, and to the calibration facilities of other International Standards Organization members.

ISO 9001 Certification

Produced to ISO 9001 international quality system standard as part of our objective of continually increasing customer satisfaction through improved process control.

Edition 6: 81610-90A15 February 2015

Edition 1:
81610-90014 E0900
September 2000

Edition 2:
81610-90014 E1000
October 2000

Edition 3:
81610-90014 E0201
February 2001

Edition 4:
81610-90014 E0401
April 2001

Edition 5:
81610-90A15
February 2002

Safety Considerations

The following general safety precautions must be observed during all phases of operation, service, and repair of this instrument. Failure to comply with these precautions or with specific warnings elsewhere in this manual violates safety standards of design, manufacture, and intended use of the instrument. Keysight Technologies assumes no liability for the customer's failure to comply with these requirements.

Before operation, review the instrument and manual, including the red safety page, for safety markings and instructions. You must follow these to ensure safe operation and to maintain the instrument in safe condition.

WARNING

The WARNING sign denotes a hazard. It calls attention to a procedure, practice or the like, which, if not correctly performed or adhered to, could result in injury or loss of life. Do not proceed beyond a WARNING sign until the indicated conditions are fully understood and met.

Safety Symbols



The apparatus will be marked with this symbol when it is necessary for the user to refer to the instruction manual in order to protect the apparatus against damage.



Hazardous laser radiation.

Initial Inspection

Inspect the shipping container for damage. If there is damage to the container or cushioning, keep them until you have checked the contents of the shipment for completeness and verified the instrument both mechanically and electrically.

The Performance Tests give procedures for checking the operation of the instrument. If the contents are incomplete, mechanical damage or defect is apparent, or if an instrument does not pass the operator's checks, notify the nearest Keysight Technologies Sales/Service Office.

WARNING

To avoid hazardous electrical shock, do not perform electrical tests when there are signs of shipping damage to any portion of the outer enclosure (covers, panels, etc.).

WARNING

You *MUST* return instruments with malfunctioning laser modules to a Keysight Technologies Service Center for repair and calibration.

Line Power Requirements

Keysight 81610A/13A Return Loss Modules operate when installed in the Keysight 8163A/B Lightwave Multimeter, Keysight 8164A/B Lightwave Measurement System, and Keysight 8166A/B Lightwave Multichannel System.

Operating Environment

The safety information in the Keysight 8163A/B Lightwave Multimeter, Keysight 8164A/B Lightwave Measurement System, and Keysight 8166A/B Lightwave Multichannel System User's Guide summarizes the operating ranges for Keysight 81610A/13A Return Loss Modules. In order for these modules to meet specifications, the operating environment must be within the limits specified for the Keysight 8163A/B Lightwave Multimeter, Keysight 8164A/B Lightwave Measurement System, and Keysight 8166A/B Lightwave Multichannel System.

Storage and Shipment

This module can be stored or shipped at temperatures between -40°C and $+70^{\circ}\text{C}$. Protect the module from temperature extremes that may cause condensation within it.

Initial Safety Information for Return Loss Modules

The laser sources specified by this user guide are classified according to IEC 60825-1 (2007).

The laser sources comply with 21 CFR 1040.10 except for deviations pursuant to Laser Notice No. 50 dated 2007-June-24:

Table 1 Return Loss Modules Laser Safety Information

	Keysight 81613A
<i>Laser type</i>	FP-Laser InGaAsP
<i>Wavelength ($\pm 15\text{nm}$)</i>	1550/1625 nm
<i>Max. CW output power*</i>	<1.8mW
<i>Beam waist diameter</i>	9 μm
Numerical aperture	0.1
<i>Laser Class according to IEC 60825-1 (2007)</i>	1
<i>Max. permissible CW output power</i>	10 mW
* Max. CW output power is defined as the highest possible optical power that the laser source can produce at its output connector	

Laser Safety Labels

Laser class 1 label

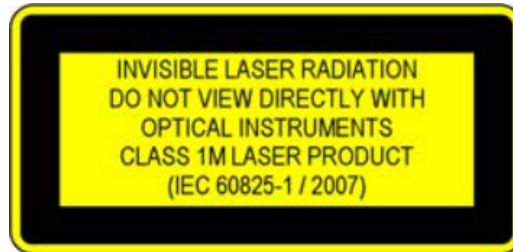

Figure 1 Class 1 Safety Label - Keysight 81613A

WARNING

Please pay attention to the following laser safety warnings:

- Under no circumstances look into the end of an optical cable attached to the optical output when the device is operational. The laser radiation can seriously damage your eyesight.
- Do not enable the laser source when there is no fiber attached to the optical output connector.
- The laser is enabled by pressing the gray button close to the optical output connector on the front panel of the module. The laser is on when the green LED on the front panel of the instrument is lit.
- The use of optical instruments with this product will increase eye hazard.
- The laser module has a built-in safety circuitry which will disable the optical output in the case of a fault condition.
- Refer servicing only to qualified and authorized personnel.

Environmental Information

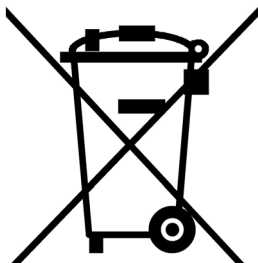

This product complies with the WEEE Directive (2002/96/EC) marking requirements. The affixed label indicates that you must not discard this electrical/ electronic product in domestic household waste.

Product Category: With reference to the equipment types in the WEEE Directive Annex I, this product is classed as a "Monitoring and Control instrumentation" product.

Do not dispose in domestic household waste.

To return unwanted products, contact your local Keysight office, or see <http://about.keysight.com/en/companyinfo/environment/takeback.shtml> for more information.

The Structure of this Manual

This manual is divided into two categories:

- Getting Started
This section gives an introduction to the Tunable Laser modules, and aims to make these modules familiar to you:
 - “*Getting Started with Return Loss*” on page 15.
- Additional Information
This is supporting information of a non-operational nature, this contains information concerning accessories, specifications, and performance tests:
 - “*Accessories*” on page 47,
 - “*Specifications*” on page 49
 - “*Performance Tests*” on page 59

Conventions used in this manual

- Hardkeys are indicated by italics, for example, *Config*, or *Channel*.
- Softkeys are indicated by normal text enclosed in square brackets, for example, [Menu] or [Details].
- Parameters are indicated by italics enclosed by square brackets, for example, [*RLref*], or [*Para*].
- Menu items are indicated by italics enclosed in brackets, for example, <*Terminated Calibration*>, or <*Continuous*>.

Table of Contents

Safety Considerations	5
<hr/>	
Safety Symbols	5
Initial Inspection	5
Line Power Requirements	6
Operating Environment	6
Storage and Shipment	6
Initial Safety Information for Return Loss Modules	7
Laser Safety Labels	8
Environmental Information	9
The Structure of this Manual	10
Conventions used in this manual	10
Getting Started with Return Loss	15
<hr/>	
The Return Loss Module	16
A Description of the Front Panel	18
Optical Output	18
What is Return Loss?	19
What is Insertion Loss?	20
How to Choose a Light Source	21
Calibration Measurements	22
Making a Return Loss Measurement	22
Setup	23
Calibrating the Return Loss Module	25
Calibration using the Keysight 81000BR Reference Reflector	26
Reflectance Calibration	26
Termination Calibration	28
Calibration using the Keysight 81610CC Reference Cable	29
Reflectance Calibration	29
Front Panel Delta Calibration	30
Termination Calibration using the Measurement Patchcord	32
How to Measure Return Loss	34
Viewing the Calibration Values	35
Keysight 81610A/11A/12A/13A/14A Return Loss Module, Edition 6	11

Table of Contents

A Background to Return Loss Measurement	38
Measuring the Reflected Power from a Component with Known Reflection Factor	38
Measuring the Power Transmitted Through the Reflection Reference	39
Measuring the Power when there are No Reflections	39
Measuring the Power Transmitted Through the Measurement Patchcord	40
Measuring the Reflections from the DUT	40
Measuring the Power Transmitted Through the DUT	41
Calculating the Return Loss of the DUT	41
Calculating the Front Panel Delta	43
Calculating the Insertion Loss of the DUT	45
Accessories	47
<hr/>	
Modules and Options	48
Specifications	49
<hr/>	
Definition of Terms	50
Return Loss	50
Return loss of the reference cable	50
Dynamic Range	51
External Input Power Range	51
External Input Damage Power	51
Center Wavelength	51
Wavelength Range	51
Relative Uncertainty	51
Total Uncertainty	53
Plug & Play	53
Return Loss Module Specifications	54
Return Loss Module Specifications with Internal Source	56
Performance Tests	59
<hr/>	
Equipment Required	60
Test Record	61
Test Failure	61

Instrument Specification	61
Performance Test Instructions	62
Keysight 81610A: Relative Uncertainty of Return Loss and Dynamic Range Test	62
Example for Keysight 81610A Return Loss module	66
Keysight 81610A/13A: Relative Uncertainty of Return Loss and Dynamic Range	67
Calibrating the 81610CC Reference Cable	72
Cleaning Information	87
<hr/>	
Safety Precautions	88
Why is it important to clean optical devices?	88
What do I need for proper cleaning?	89
Standard Cleaning Equipment	89
Dust and shutter caps	89
Isopropyl alcohol	90
Cotton swabs	90
Soft tissues	90
Pipe cleaner	91
Compressed air	91
Additional Cleaning Equipment	92
Microscope with a magnification range about 50X up to 300X	92
Ultrasonic bath	92
Warm water and liquid soap	92
Premoistened cleaning wipes	93
Polymer film	93
Infrared Sensor Card	93
Preserving Connectors	93
Cleaning Instrument Housings	94
Which Cleaning Procedure should I use ?	94
How to clean connectors	95
How to clean connector adapters	96
How to clean connector interfaces	97
How to clean bare fiber adapters	98
How to clean lenses	99
How to clean instruments with a fixed connector interface	99
How to clean instruments with an optical glass plate	101

Table of Contents

How to clean instruments with a physical contact interface	101
How to clean instruments with a recessed lens interface	102
How to clean optical devices which are sensitive to mechanical stress and pressure	103
How to clean metal filters or attenuator gratings	104
Additional Cleaning Information	105
How to clean bare fiber ends	105
How to clean large area lenses and mirrors	105
Other Cleaning Hints	107

Getting Started with Return Loss

This chapter describes the use of use the Keysight 81610A Return Loss module.

Here you will find:

- an introduction to the features of the module, its front panel, and connectors.
- a brief explanation of the terms Return Loss and Insertion Loss,
- a description of how to use the module to measure Return Loss and Insertion Loss,
- a brief discussion of the theoretical background to Return Loss measurements using Keysight 8161x series Return Loss modules.

The Return Loss Module

What is a Return Loss Module? Keysight 8161xA series Return Loss modules are compact modules for use with the Keysight 8163B Lightwave Multimeter, the Keysight 8164B Lightwave Measurement System, and the Keysight 8166B Lightwave Multichannel System. They are used for making return loss measurements and, in conjunction with a power meter module, insertion loss measurements.

A return loss module allows you to measure the light reflected and scattered as light passes through an optical component. In many applications, these affects are unwanted because they can affect the emission characteristics of any laser in the system.

Keysight 81610A Return Loss module The Keysight 81610A Return Loss Module includes a power sensor, monitor diode and two couplers in one module.

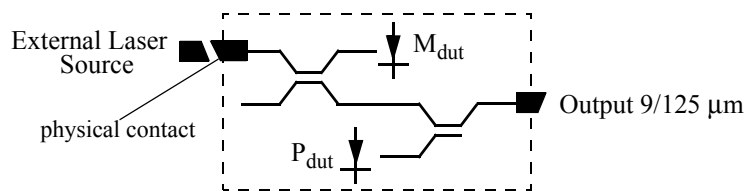

Figure 2 The Keysight 81610A Return Loss module

The Keysight 81610A series Return Loss module does not include an internal laser source. It is used in conjunction with an appropriate external source to perform return loss measurements on both WDM components and broadband devices.

Keysight 81613A Return Loss modules Keysight 81613A Return Loss module include a power sensor, monitor diode, three couplers, and two internal laser source in one module. They are for use in the Keysight 8163B Lightwave Multimeter, the Keysight 8164B Lightwave Measurement System, and the Keysight 8166B Lightwave Multichannel System for making return loss measurements.

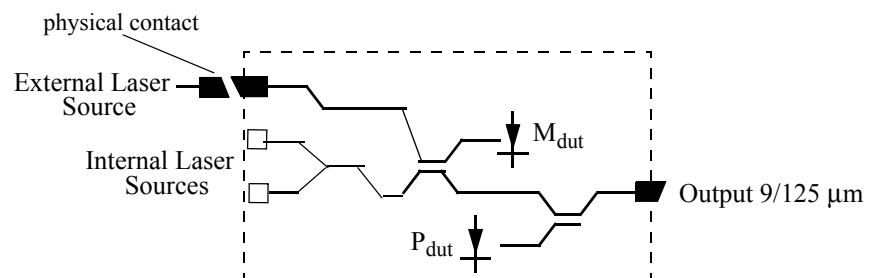

Figure 3 The Contents of the Keysight 81613A Return Loss modules

All Keysight 8161x series Return Loss modules include a monitor diode to compensate for power variation in the light source.

A Description of the Front Panel

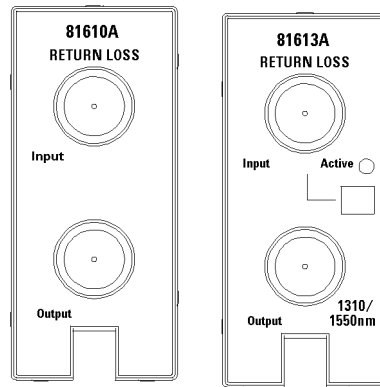

Figure 4 Front Panel of Keysight 816010A/13A Return Loss Modules

Inserting the module The procedure for inserting a module into your mainframe is described in your mainframe's User's Guide.

Optical Output

Keysight 8161x series Return Loss modules are equipped with angled (8°) contact optical input and output connectors.



Figure 5 Angled Contact Connector Symbols

Figure 5 shows the symbol for angled contact connectors. This symbol is colored green.

CAUTION

- In order to obtain reliable return loss values connectors must be in good condition.

Damage to connectors is not included in the warranty for the Keysight 8161x series Return Loss modules

What is Return Loss?

When light passes through an optical component most of it travels in the intended direction, but some light is reflected or scattered. In many applications these reflections are unwanted, because they can affect the emission characteristics of any laser in the system. In such applications, it is important to measure the reflections for the components of the system.

The reflection factor for a component is a measure of how much light the component reflects. It is a ratio of the power reflected by the device to the power incident on the device. More normally we talk about the return loss of a component. The return loss has units of dB. Return loss is given by:

$$\text{Return Loss}(dB) = -10\log(\text{Reflection Factor}) (dB)$$

or

$$\text{Return Loss}(dB) = -10\log\frac{\text{Reflected Power}}{\text{Incident Power}} (dB)$$

Return loss can be measured in several ways. A typical setup using the Keysight 81610A Return Loss module, where the DUT is a connector pair, is described in [Figure 6](#).

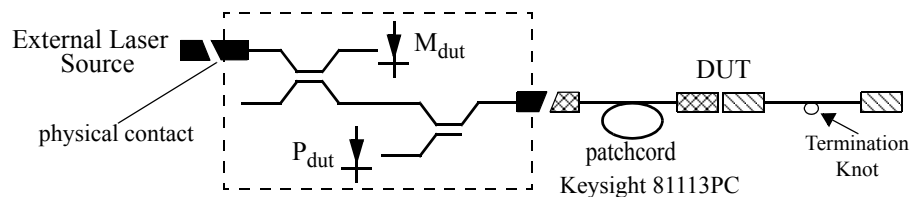

Figure 6 Return Loss Equipment

What is Insertion Loss?

Light that is absorbed, scattered, or reflected by a component also affects how much light a component transmits.

The transmission factor for a component is a measure of how much light the component transmits. It is a ratio of the power transmitted by the device to the power incident on the device. More normally we talk about the Insertion Loss of a component. The insertion loss has units of dB. Insertion Loss is given by:

$$\text{Insertion Loss}(dB) = -10\log(\text{Transmission Factor}) (dB)$$

or

$$\text{Insertion Loss}(dB) = -10\log\left(\frac{\text{Transmitted Power}}{\text{Incident Power}}\right) (dB)$$

Insertion Loss can be measured in several ways.

A typical setup using the Keysight 81610A Return Loss module, where the DUT is a connector pair, is described in [Figure 7](#)

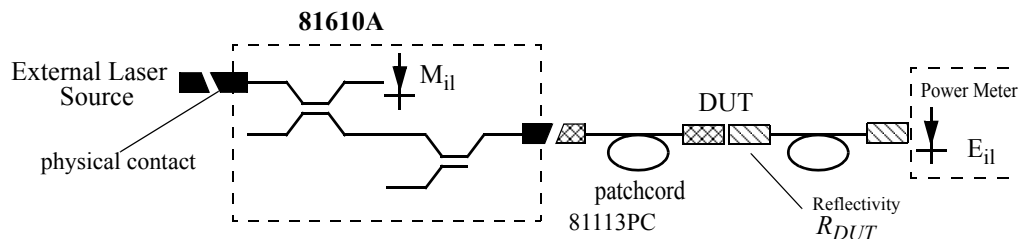

Figure 7 Measuring the Power transmitted through the Device Under Test

You can use E_{il} to calculate the insertion loss, see “*Calculating the Insertion Loss of the DUT*” on page 45

How to Choose a Light Source

Highly accurate return loss measurement requires that you use a light source with a subset of the following properties:

- low coherence length
- high power

If a return loss module with at least one internal source (such as the Keysight 81613A) is not available, we recommend that you use any of the following as part of your return loss measurement setup:

- *Laser Source modules.*
Refer to the “*Accessories*” section of your mainframe’s User’s Guide for a list of the modules that can be installed. Refer to the note below that explains use with highly coherent light sources.
- *Tunable Lasers* when you want to measure Return Loss over a wavelength range.
Refer to the “*Accessories*” section of your mainframe’s User’s Guide for a list of the modules that can be installed. Refer to the note below that explains use with highly coherent light sources.
- *LED sources.*
The intensity of the output of LED sources is very stable over time, although the low power output of LEDs restricts the dynamic range of return loss measurement.

NOTE

If you use high-coherence light sources, you can improve performance by:

- modulating the output signal at 2 kHz or higher, or
- using the coherence control to reduce the coherence length of the signal.

Calibration Measurements

Before measuring the reflection factor of a device under test (DUT), take calibration measurements as described in “[Calibrating the Return Loss Module](#)” on page 25. These calibrations eliminate wavelength dependencies, coupler directivity, insertion losses, backscattering and other non-ideal characteristics of the system.

Making a Return Loss Measurement

Connectors Fiber patchcords for measurement or calibration must have an angled, APC, connector at the return loss module output port.

Setup

The Return Loss measurement setup described uses a Keysight 81654A Source module, inserted as a second module in the the same mainframe as the Return Loss module.

- 1 Making sure all the connectors are clean, set up the instrument as shown in **Figure 8** if you are using an External Source,

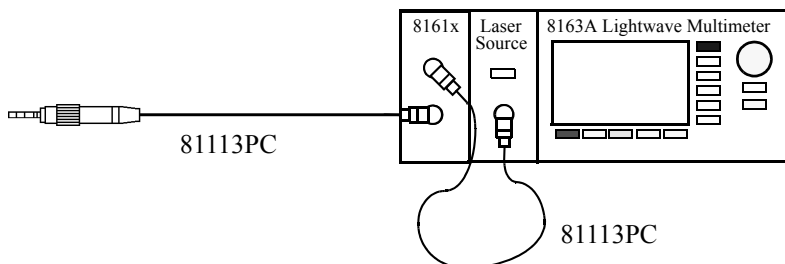

Figure 8 Return Loss Measurement Setup - External Source used

or **Figure 9** if you are using an internal source (Keysight 81613A Return Loss module only).

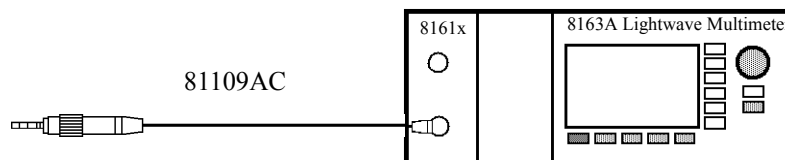

Figure 9 Return Loss Measurement Setup - Internal Source used

- If an external source is used, connect the external source to the Return Loss module Input.

NOTE

If you are using a Fabry-Perot source, you must fix its output cable to ensure minimum cable movement.

- Attach the high return loss connector of the patchcord to the Return Loss module Output.

- 2 **Remove electrical offsets** Make sure that the source is not active and that you have covered the end of the patchcord to prevent light being coupled into the end. Move to the Return Loss module channel and press [Zero] to remove electrical offsets in the instrument.

- Set Averaging Time** 3 Move to the [AveTime] parameter (the measurement averaging time). Make sure that the selected averaging time is suitable for your measurements.
- Use an averaging time of at least 200 ms, but increase this to at least 1 s for return losses greater than 50 dB. Longer averaging times give more accurate results, but reduce the speed at which the instrument can complete a measurement.

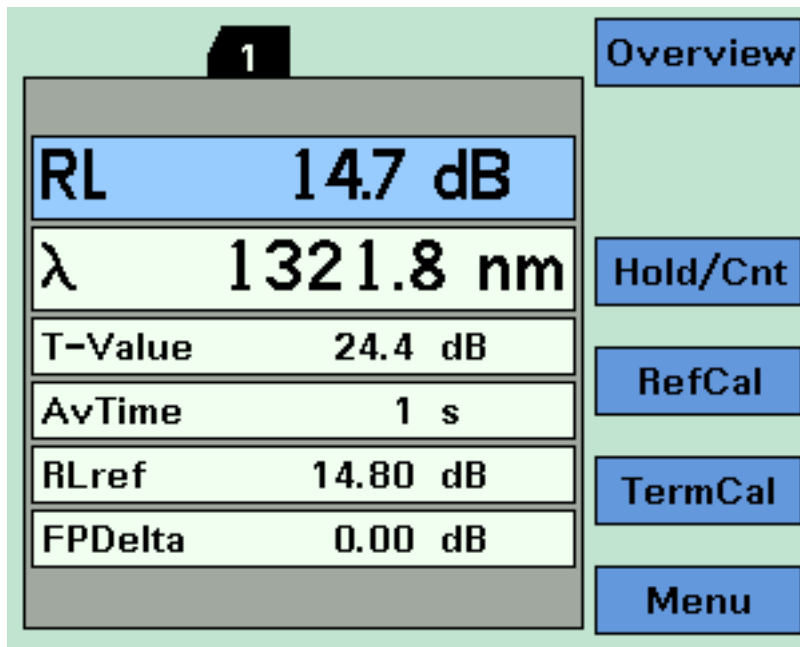

Figure 10 Keysight 8161x Details Screen

- Set Wavelength** 4 Move to [λ], then set this parameter to *Extern*.
- 5 Enable the source.

Calibrating the Return Loss Module

Whenever a Return Loss module is in the mainframe, a return loss value is displayed. The calibration values used are either the most recently measured, where these are available, or factory default values.

If you are unsure of any of the calibration values that you are using, or if you have changed the measurement setup, take the appropriate calibration measurements again.

- First, calibrate the return loss module against a component of known reflectance.
 - The Keysight 81000BR Reference Reflector allows you to make a Reflectance Calibration and a Termination Calibration. These procedures are described in “[Calibration using the Keysight 81000BR Reference Reflector](#)” on page 26.
 - The Keysight 81610CC Reference Cable also allows you to make a Reflectance Calibration. Use the measurement patchcord to make a Termination Calibration.

To measure insertion loss and the front panel delta of the system (see “*Calculating the Front Panel Delta*” on page 43), you must also measure the insertion loss of the Reference Cable and measurement patchcord.

These procedures are described in “[Calibration using the Keysight 81610CC Reference Cable](#)” on page 29.

Calibration using the Keysight 81000BR Reference Reflector

You can use the Keysight 81000BR Reference Reflector to make a Reflectance Calibration, and a Termination Calibration.

Reflectance Calibration

Use this procedure to calibrate the Return Loss module against a component of known return loss.

- 1 Making sure all the connectors are clean, set up the instrument as shown in [Figure 11](#) if you are using an External Source,

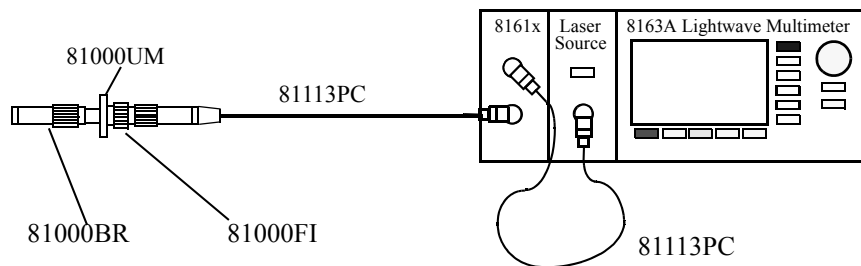

Figure 11 Reflectance Calibration - External Source

or [Figure 12](#) if you are using an internal source (Keysight 81613A Return Loss module only).

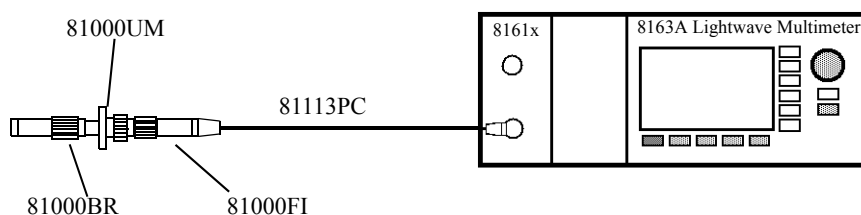

Figure 12 Reflection Calibration - Internal Source

- TIP** For best results and higher repeatability, fix the cable.
- 2 Attach a component with a known return loss to the end of the patchcord.
- TIP** The Keysight 81000BR Back Reflector is such a component, offering a return loss of 0.18 ± 0.1 dB.
- 3 Move to the Return Loss channel, then press [Details]
 - 4 Move to [*FPDelta*], press [Edit], set the value to 0.000, then press [OK].
 - 5 Move to [*RLref*>] and make sure that the displayed value is correct. Set [*RLref*] to the value of the return loss of the reference reflection you are

using. For example, if you are using the Keysight 81000BR reference reflector, set $[RLref]$ to 0.18 dB.

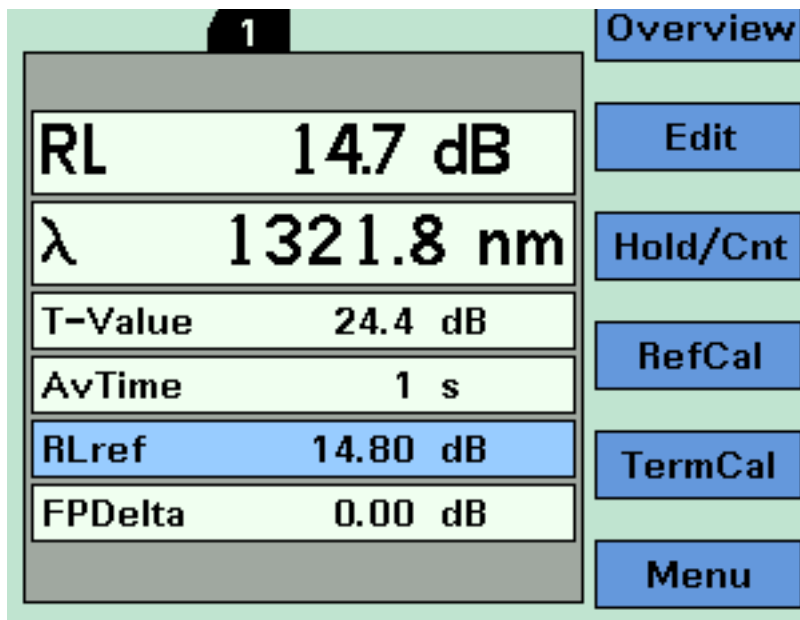

Figure 13 Measuring the Reflection Reference

- 6 Press [Menu]. Move to *<Reflectance calibration>* and press [Enter]. The instrument measures the power reflected by the back reflector. The $[RL]$ value changes to the same value as entered for $[RLref]$.

Tip An alternative step 6 is to select the Return Loss module's [Detail] screen, then press [RefCal]

Termination Calibration

Use this procedure to calibrate the Return Loss module against a terminated cable, that is when there are no reflections returning from its end.

- 1 Making sure all the connectors are clean, set up the instrument as shown in [Figure 14](#)

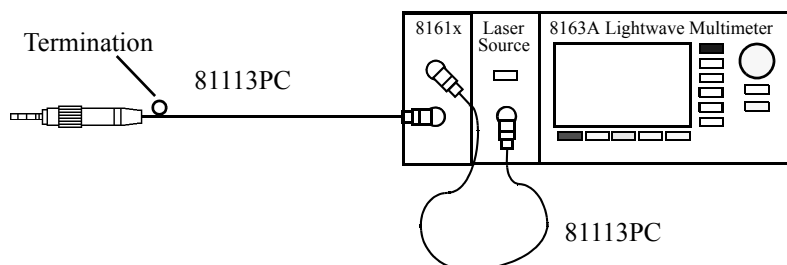

Figure 14 Termination Calibration - External source

or [Figure 15](#) if you are using an internal source (Keysight 81613A Return Loss module only).

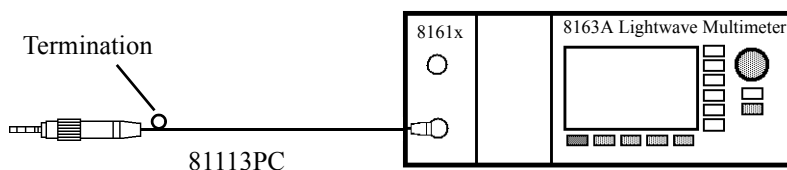

Figure 15 Termination Calibration - Internal Source

NOTE

If you are using a Fabry-Perot source, you must fix its output cable to ensure minimum cable movement.

- 2 Terminate the cable so that there are no reflections coming from the end.

TIP You can do this by wrapping the fiber five times around the shaft of a screwdriver (or some similar object with a diameter of between 5mm and 7mm).

- 3 Press [Menu] to access the menu.
- 4 Move to *<Terminated calibration>* and press [Enter]. The instrument measures the power reflected by the cable, and sets the [Para] values used by the Return Loss monitor's power sensor and monitor diode.

TIP An alternative steps 3 and 4 is to select the Return Loss module's [Details] screen, then press [TermCal].

Calibration using the Keysight 81610CC Reference Cable

Use the Keysight 816100CC Reference Cable to make a Reflectance Calibration, and the measurement patchcord to make a Termination Calibration.

To measure insertion loss and the front panel delta of the system (see “Calculating the Front Panel Delta” on page 43), you must also measure the insertion loss of the Reference Cable and measurement patchcord.

Reflectance Calibration

Use this procedure to calibrate the Return Loss module against a component of known return loss.

- 1 Attach the source to the Return Loss module’s input as shown in Figure 16. Attach the high return loss connector of the reference cable to the output.

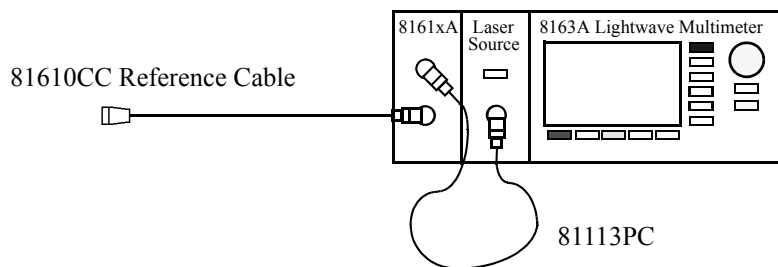

Figure 16 Measuring the Return Loss of the Reference Cable - External source or Figure 17 if you are using an internal source (Keysight 81613A Return Loss modules only).

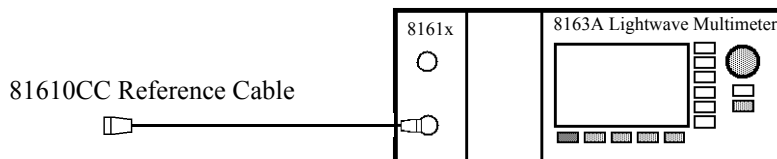

Figure 17 Measuring the Return Loss of the Reference Cable - Internal Source

Attach the high return loss connector of the reference cable to the output.

TIP For best results and higher repeatability, fix the cable.

- 2 Move to [FPDelta], press [Edit], set the value to 0.000, then press [OK].
- 3 Move to [RLref], press [Edit]. Make sure that the displayed value of $\langle RLref \rangle$ is correct. If it is not, move to [RLref], press [Edit], set the value the return loss value of the reference cable you are using, then press [OK].

- 4 Press [Menu]. Move to <Reflectance calibration> and press Enter. The instrument measures the power reflected by the reference cable. The [RL] value changes to the same value as entered for [RLref].

Front Panel Delta Calibration

For higher accuracy we recommend that you also calibrate for *Front Panel Delta*. This is the difference between the insertion loss of the reference cable, and the insertion loss of the patchcord used for return loss measurement.

Measuring the Power Transmitted through the Reference Cable

First, measure the power transmitted through the Reference Cable.

- 1 Making sure all the connectors are clean, set up the instrument as shown in **Figure 18**

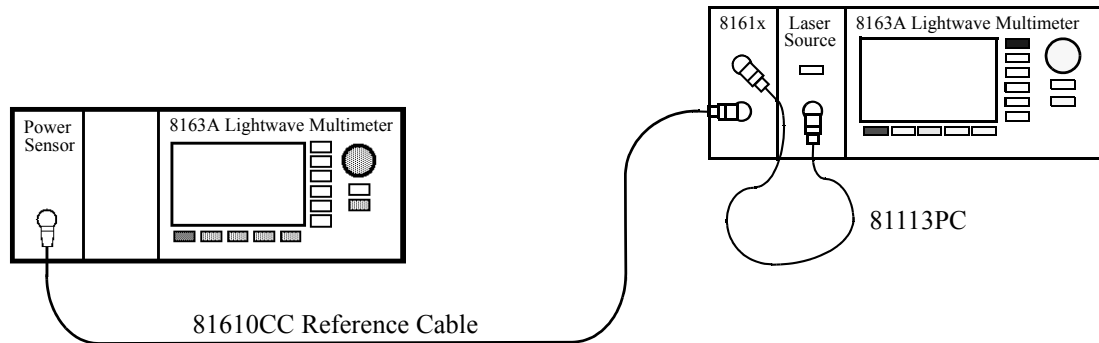

Figure 18 Measuring the Power Transmitted through the Reference Cable - External Source

or **Figure 19** if you are using an internal source (Keysight 81613A Return Loss modules only).

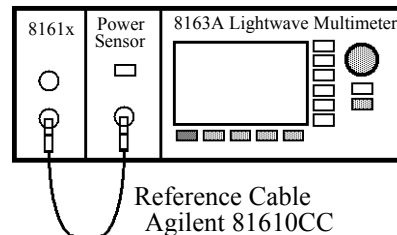

Figure 19 Measuring the Power Transmitted through the Reference Cable - Internal Source

- 2 Move to the Power Sensor channel:
 - Press [Menu].

- Move to *<Pwr unit>*, move to *<dB>* and press *Enter*.
 - Move to *<Display to Reference>* and press *Enter*. This sets the power transmitted through the reference cable, E_{Meas} , as the reference value *<Ref>*.
- 3 Press [Close] to exit from the menu.

Measuring the Power Transmitted through the Measurement Patchcord

Next, measure the power transmitted through the measurement patch cord.

- 1 Making sure all the connectors are clean, set up the instrument as shown in **Figure 20**

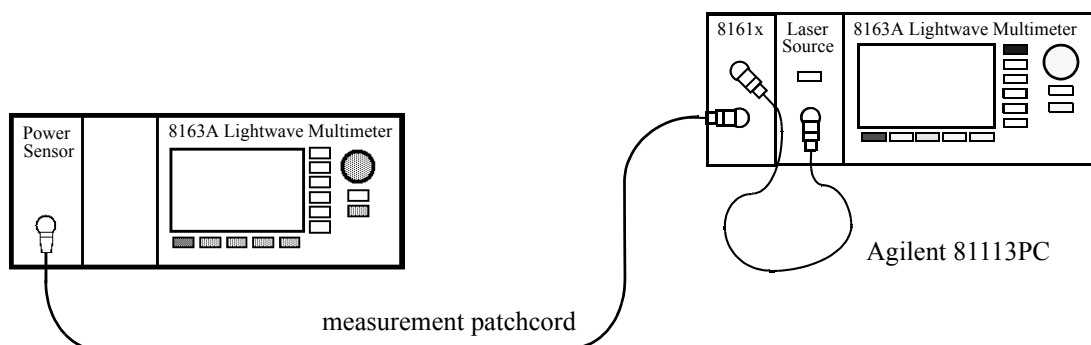

Figure 20 Measuring the Power Transmitted through the Measurement Patchcord or **Figure 21** if you are using an internal source (Keysight 81613A Return Loss modules only).

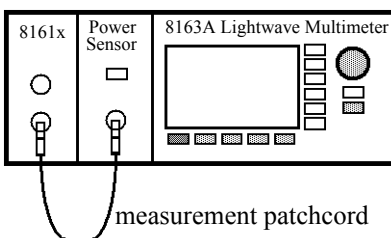

Figure 21 Measuring the Power Transmitted through the Measurement Patchcord - Internal Source

- 2 Move to the Power Sensor channel:
- Press [Menu].
 - If necessary, move to *<Pwr unit>*, move to *<dB>* and press *Enter*.
 - The Power Sensor channel displays a power value in dB that is equal to the front panel delta of the measurement system.
 - Press [Close] to exit from the menu.
- 3 Move to the Return Loss module channel:

- Press [Menu], move to <FPDelta>, press [OK]
- Enter the power value in dB, [P], displayed by the power sensor, as the front panel delta, then press [OK].
- Press [Close] to exit from the menu.

Termination Calibration using the Measurement Patchcord

Use this procedure to calibrate the Return Loss module against a terminated patchcord, that is when there are no reflections returning from its end.

- 1 Making sure all the connectors are clean, set up the instrument as shown in [Figure 22](#)

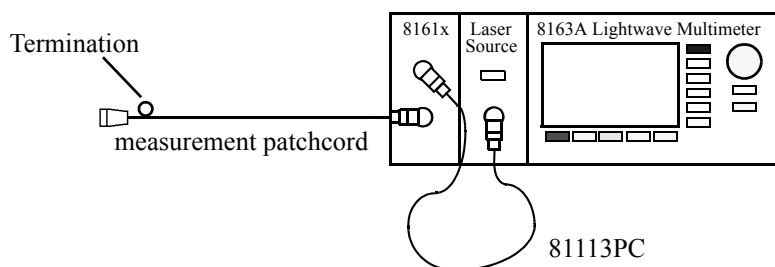

Figure 22 Measuring the Termination Parameter - External Source

or [Figure 23](#) if you are using an internal source (Keysight 81613A Return Loss modules only).

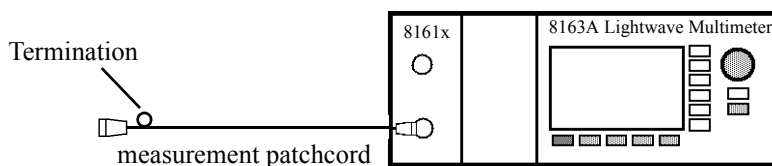

Figure 23 Measuring the Termination Parameter - Internal Source

- 2 Terminate the measurement patchcord so that there are no reflections coming from the end.

TIP You can do this by wrapping the fiber five times around the shaft of a screwdriver (or some similar object with a diameter of between 5mm and 7mm).

- 3 Move to *<Terminated calibration>* and press *Enter*. The instrument measures the power reflected by the component, and sets the [Para] values used by the Return Loss monitor's power sensor and monitor diode.

How to Measure Return Loss

It is not necessary to make new calibration measurements for each DUT. You can make the calibration measurements for your system, and then measure the return loss of many devices.

The value shown in the result field for the Return Loss channel is the measured return loss.

- 1 Attach the DUT to the measurement patchcord. In the example shown in [Figure 24](#), the DUT is a connector pair.

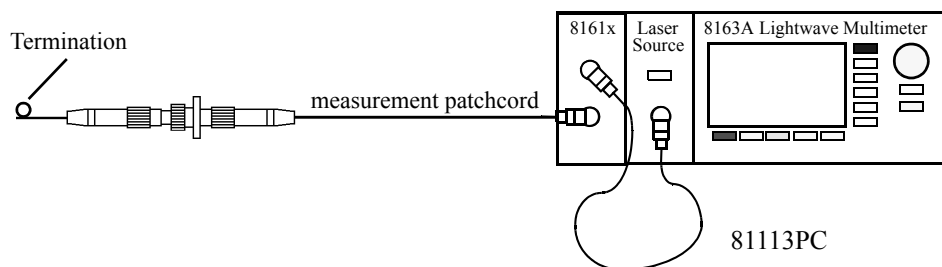
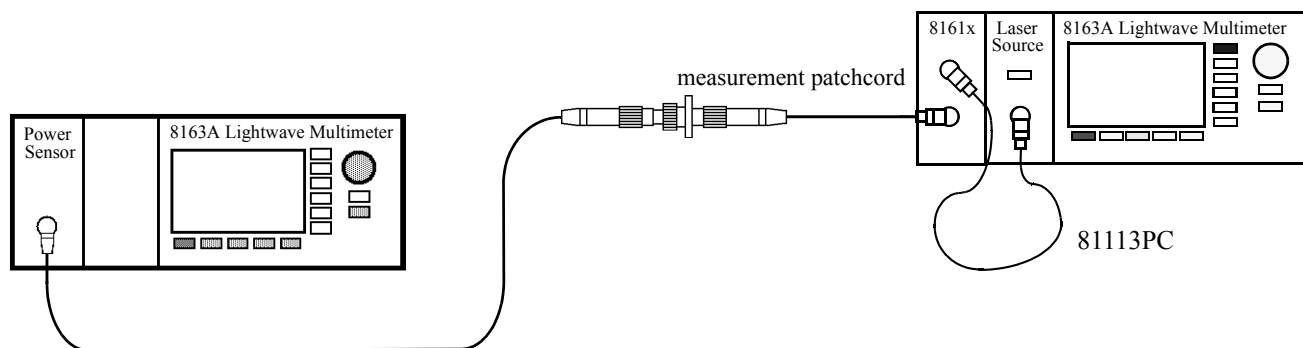

Figure 24 Measuring the Return Loss of the DUT (in this example: a Connector Pair)

TIP Terminate your system close to the DUT to make sure that you are only measuring reflections from the DUT.

Figure 25 Measuring the Power Transmitted through the DUT (a Connector Pair)



Measuring the Insertion Loss To measure insertion loss, you measure the power transmitted through the DUT, as shown in [Figure 25](#).

As you have already, in [Step 2 on page 30](#), set the [Ref] parameter to the power transmitted through the Reference Cable. The displayed power in dB is equal to the insertion loss.

NOTE

Set the *Front Panel Delta* as described on [“Front Panel Delta Calibration” on page 30](#).

Viewing the Calibration Values

The Return Loss module calibration values used are either the most recently measured, where these are available, or factory default values.

If you are unsure of the calibration values you are using, or if you have changed your measurement setup, make the appropriate calibration measurements again.

1 Press [Menu]. Move to the *<Show calibration>* menu item. The *Calibration parameters* screen for the *Return Loss Diode* appears, as displayed in [Figure 26](#). This screen shows current value for the following quantities:

- [Para], the parasitic power value measured by the Return loss Module’s internal power sensor in dBm. This value is determined by the termination calibration, or you can use the default setting held in the factory calibration.
- [Ref], the power measured by the Return loss Module’s internal power sensor during the reflectance calibration in dBm
- [Meas], the power currently measured by the Return loss Module’s internal power sensor in dBm

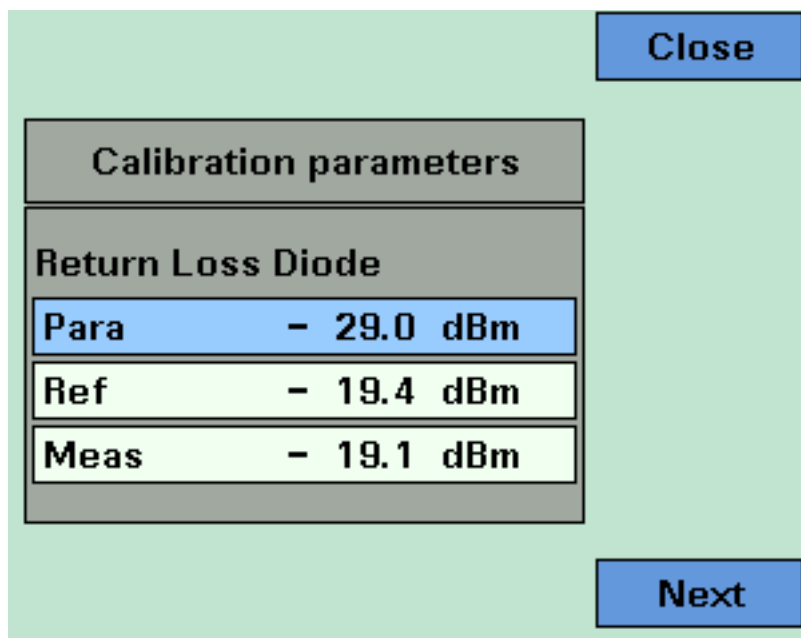

Figure 26 The Calibration Parameters Screens - Return Loss Diode

2 Press [Next]. The *Calibration parameters* screen for the *Monitor Diode* appears, as displayed in [Figure 27](#). This screen shows current value for the following quantities:

- [Para], the parasitic power value measured by the Return Loss module's monitor diode in dBm. This value is determined by the termination calibration, or you can use the default setting held in the factory calibration.
- [Ref], the power measured by the Return Loss module's monitor diode during the reflectance calibration in dBm
- [Meas], the power currently measured by the Return loss Module's internal monitor diode in dBm

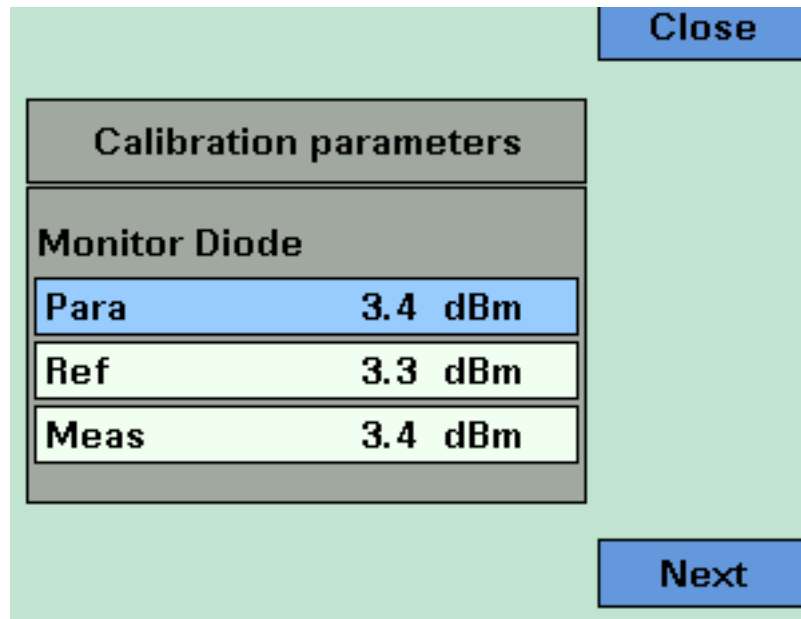

Figure 27 The Calibration Parameters Screens - Monitor Diode

3 Press [Next]. The *Calibration parameters* screen for *User Data* appears, as displayed in [Figure 28](#). This screen shows current value for the following quantities:

- [FPDelta], the loss correction, in dB, due to differences in loss between the reference cable and the measurement patchcord.

- $[RL_{ref}]$, the value of the return loss of the reference relector used. If you are using a reference cable, this value will be around 14.6 dB

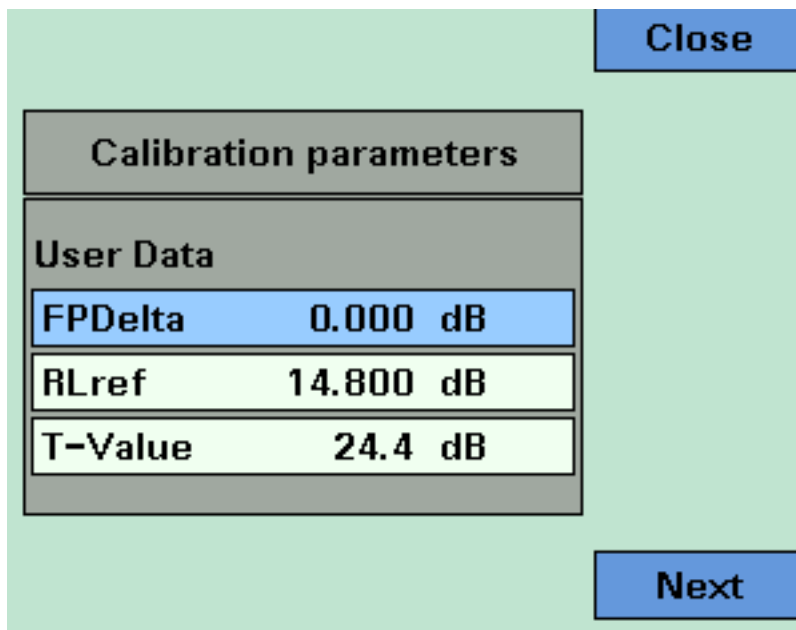

Figure 28 The Calibration Parameters Screens - User Data

A Background to Return Loss Measurement

Measuring the Reflected Power from a Component with Known Reflection Factor

First, attach a component with a known reflection factor in place of the DUT, and measure the power reflected. This component is called the reflection reference.

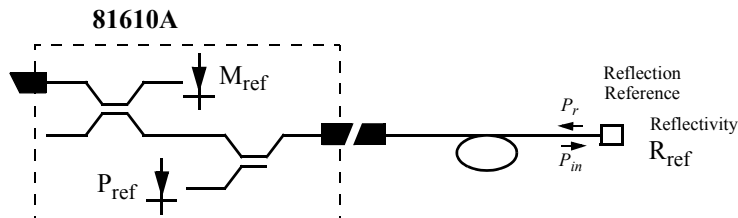

Figure 29 Measuring the Power from a Component with a Known Reflection Factor

This measured power from the reflection reference is called P_{Ref} .

The following two components are recommended for use as a reflection reference:

- the Keysight 81610CC Reference Cable, or
- the Keysight 81000BR Back Reflector.

NOTE

Note you can only measure the Front Panel Delta if you use a Reflection Reference Cable.

The reflection factor for the component is called R_R . Normally the return loss for the component (RL_R) is specified, but these values are related:

$$RL_R = -10\log R_R = -10\log \frac{P_r}{P_{in}}$$

Measuring the Power Transmitted Through the Reflection Reference

NOTE

Note you can only measure the Front Panel Delta if you use the a Reflection Reference Cable.

Connect your a Reflection Reference Cable to a Power Meter and measure the transmitted power, E_{ref} . You can use E_{ref} to calculate the front panel delta, see “Calculating the Front Panel Delta” on page 43.

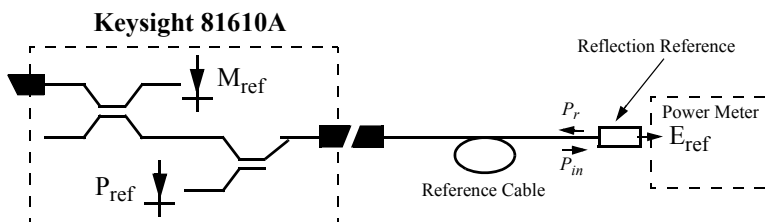

Figure 30 Measuring the Power transmitted through the Reflection Reference

Measuring the Power when there are No Reflections

Next, terminate the measurement patchcord so that there are no reflections from the end. All the power measured by the sensor now, is due to the non-ideal nature of the measurement system. This is our termination parameter.

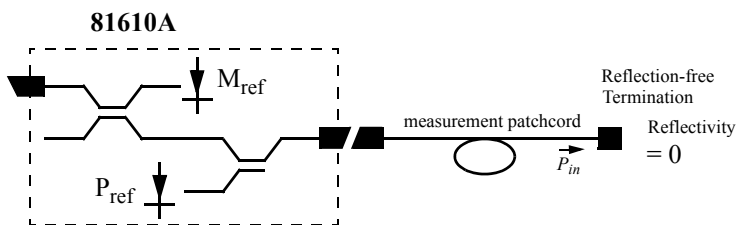

Figure 31 Measuring the Power with the Connector Terminated

This measured power for the termination parameter is called P_T .

Measuring the Power Transmitted Through the Measurement Patchcord

Connect the measurement patch cord (the cable you will use to connect to the Device Under Test, DUT) directly to a Power Meter and measure the transmitted power, E_{Meas} . You can use E_{Meas} to calculate the front panel delta, see “Calculating the Front Panel Delta” on page 43 and to calculate the insertion loss, see “Calculating the Insertion Loss of the DUT” on page 45.

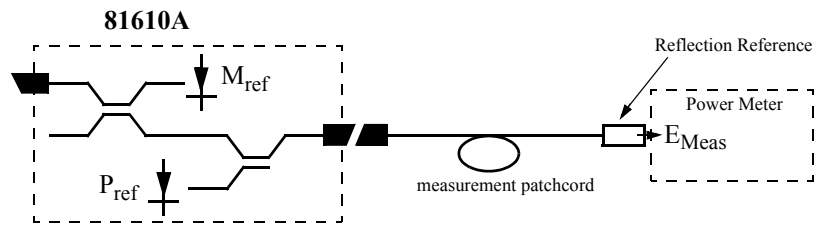

Figure 32 Measuring the Power transmitted through the Measurement Patchcord

Measuring the Reflections from the DUT

Now detach the measurement patchcord from the Power Meter and attach it to the DUT. The DUT should be terminated.

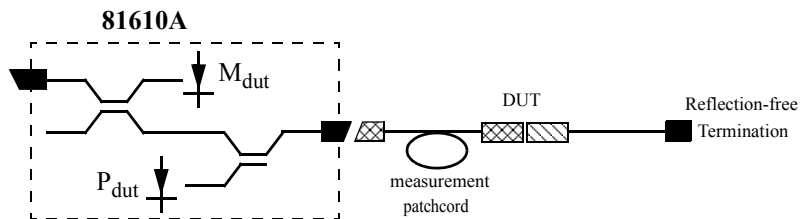

Figure 33 Measuring the Reflections from the Device Under Test

The instrument measures the power reflected from the DUT. This power is called P_{DUT} .

Measuring the Power Transmitted Through the DUT

Unterminate the DUT and connect the DUT to a Power Meter so that the power that is transmitted through the DUT can be measured. This power is called E_{il}

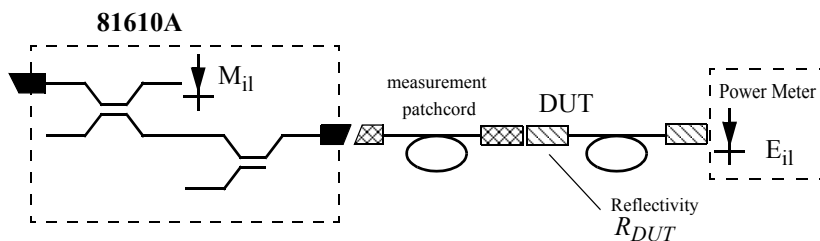
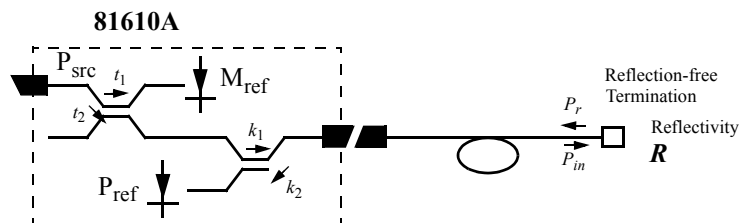

Figure 34 Measuring the Power transmitted through the Device Under Test

You can use E_{il} to calculate the insertion loss, see “*Calculating the Insertion Loss of the DUT*” on page 45.

Calculating the Return Loss of the DUT

The system may be represented by the general diagram shown below:



The reflected power, measured by the instrument, (P), from the component with the known reflection factor, is given by the sum of:

- the part of the power, reflected by the component, which is transmitted through the coupler, and
- the reflections due to the measurement system.

That is:

$$P = t_2 k_1 k_2 P_{src} R + t_2 s M$$

where:

$$M = t_1 P_{src}$$

$$c_1 = \frac{t_2}{t_1} k_1 k_2$$

$$c_2 = \frac{t_2}{t_1} s$$

$$\Rightarrow P = c_1 M R + c_2 M \quad (1)$$

The constants t_1 , t_2 , k_1 and k_2 are multipliers giving the proportion of power transmitted through the coupler from the Input port to the Output port and from the Output port to the sensor port respectively. In other words, when optical power is input at the Output port, k_2 times that power is output at the sensor port. It is not necessary to know the value for these constants, they can be eliminated later.

The constant s is a multiplier giving the scattering factor. The scattering factor accounts for the directivity of the second coupler, backscatter in the fiber, and reflections of connectors. The calibration procedure helps you to eliminate the affect of these on return loss measurements.

For “*Making a Return Loss Measurement*” on page 22, the reflection factor of the component is known. Here we refer to the reflection factor as R_{Ref} . This gives the following equation:

$$P_{Ref} = c_1 M_{Ref} R_{Ref} + c_2 M_{Ref} \quad (2)$$

For “*Measuring the Power when there are No Reflections*” on page 39, the value of the reflection factor is zero. This gives the following equation:

$$P_{para} = c_2 M_{para} \quad (3)$$

For “*Measuring the Reflections from the DUT*” on page 40, the value of the reflection factor of the DUT is called R_{DUT} . This gives the following equation:

$$P_{DUT} = c_1 M_{DUT} R_{DUT} + c_2 M_{DUT} \quad (4)$$

If we substitute equation 3 into equations 2 and 4, this gives us the following two equations:

$$P_{Ref} = c_1 M_{Ref} R_{Ref} + \frac{M_{ref}}{M_{para}} P_{para} \quad (5)$$

$$P_{DUT} = c_1 M_{DUT} R_{DUT} + \frac{M_{DUT}}{M_{para}} P_{para} \quad (6)$$

If we subtract P_{para} from equations 5 and 6, this gives us the following equations:

$$P_{Ref} - \frac{M_{Ref}}{M_{para}} P_{para} = c_1 M_{Ref} R_{Ref} \quad (7)$$

$$P_{DUT} - \frac{M_{DUT}}{M_{para}} P_{para} = c_1 M_{DUT} R_{DUT} \quad (8)$$

If we divide equation 8 by equation 7, this gives us the following equations:

$$R_{DUT} = \frac{M_{Ref}}{M_{DUT}} \frac{P_{DUT} - \frac{M_{DUT}}{M_{para}} P_{para}}{P_{Ref} - \frac{M_{Ref}}{M_{para}} P_{para}} R_{Ref} \quad (9)$$

Thus we can use the equation below to calculate return loss:

$$\begin{aligned} RL_{DUT} &= -10 \log R_{DUT} \\ &= -10 \log \frac{M_{Ref}}{M_{DUT}} \frac{P_{DUT} - \frac{M_{DUT}}{M_{para}} P_{para}}{P_{Ref} - \frac{M_{Ref}}{M_{para}} P_{para}} - 10 \log R_{Ref} \end{aligned} \quad (10)$$

The return loss of the reference reflection is given by:

$$RL_{Ref} = -10 \log R_{Ref} \quad (11)$$

Calculating the Front Panel Delta

The Front Panel Delta is the change in loss variation that is caused by replacing the reference cable, as used in “*Reflectance Calibration*” on page 29, with the measurement patchcord, as used in “*How to Measure Return Loss*” on page 34. This is caused by differences in reflections from the front panel connector and also differences in the backscatter level of the fibers.

To measure the front panel delta you must measure the power transmitted through the reference cable, “*Measuring the Power Transmitted Through the Reflection Reference*” on page 39, and the power transmitted through the measurement cable, see “*Measuring the Power Transmitted Through the Measurement Patchcord*” on page 40. The system may be represented by **Figure 35**:

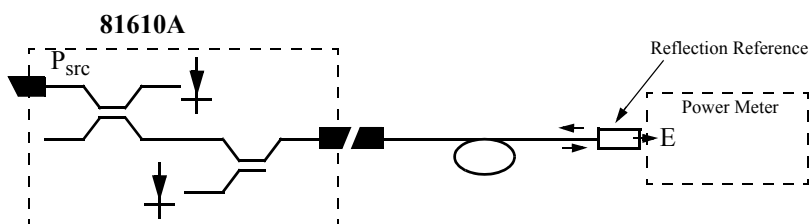

Figure 35 Generalization of a Return Loss Measurement

The transmitted power, (E), is directly proportional P_{src} .

That is:

$$E = aP_{src} \quad (12)$$

The constant a is a multiplier giving the proportion of power that the light source emits that is measured by the power meter.

The constants a_{Ref} and a_{Meas} apply to the setups described in “*Measuring the Power Transmitted Through the Reflection Reference*” on page 39 and in “*Measuring the Power Transmitted Through the Measurement Patchcord*” on page 40 respectively.

This gives the following two equations:

$$E_{Ref} = a_{Ref}P_{src} \quad (13)$$

$$E_{Meas} = a_{Meas}P_{src} \quad (14)$$

If we divide equation 11 by equation 12, this gives the following equation:

$$\frac{E_{Ref}}{E_{Meas}} = \frac{a_{Ref}}{a_{Meas}} \quad (15)$$

The loss variation, ΔL , due to exchanging the reference cable for the measurement cable is given by:

$$\Delta L = -10 \log \frac{a_{Ref}}{a_{Meas}} = -10 \log \frac{E_{Ref}}{E_{Meas}} \quad (16)$$

When you enter a value for the Front Panel Delta, $\langle FPDelta \rangle$, the instrument automatically performs the following calculation:

$$RL = RL_{DUT} + 2\Delta L \quad (17)$$

Calculating the Insertion Loss of the DUT

Insertion Loss is explained in “*What is Insertion Loss?*” on page 20.

To measure the insertion loss you must measure the power transmitted through the measurement cable, see “*Measuring the Power Transmitted Through the Measurement Patchcord*” on page 40 and the power transmitted through the DUT, see “*Measuring the Power Transmitted Through the DUT*” on page 41.

The equation below gives the insertion loss of the DUT, IL_{DUT} :

$$IL_{DUT} = -10 \log \frac{E_{il}}{E_{Meas}} \quad (18)$$

Accessories

Keysight 8161x series Return Loss modules are available in various configurations for the best possible match to the most common applications.

This chapter provides information on the available options and accessories.

Modules and Options

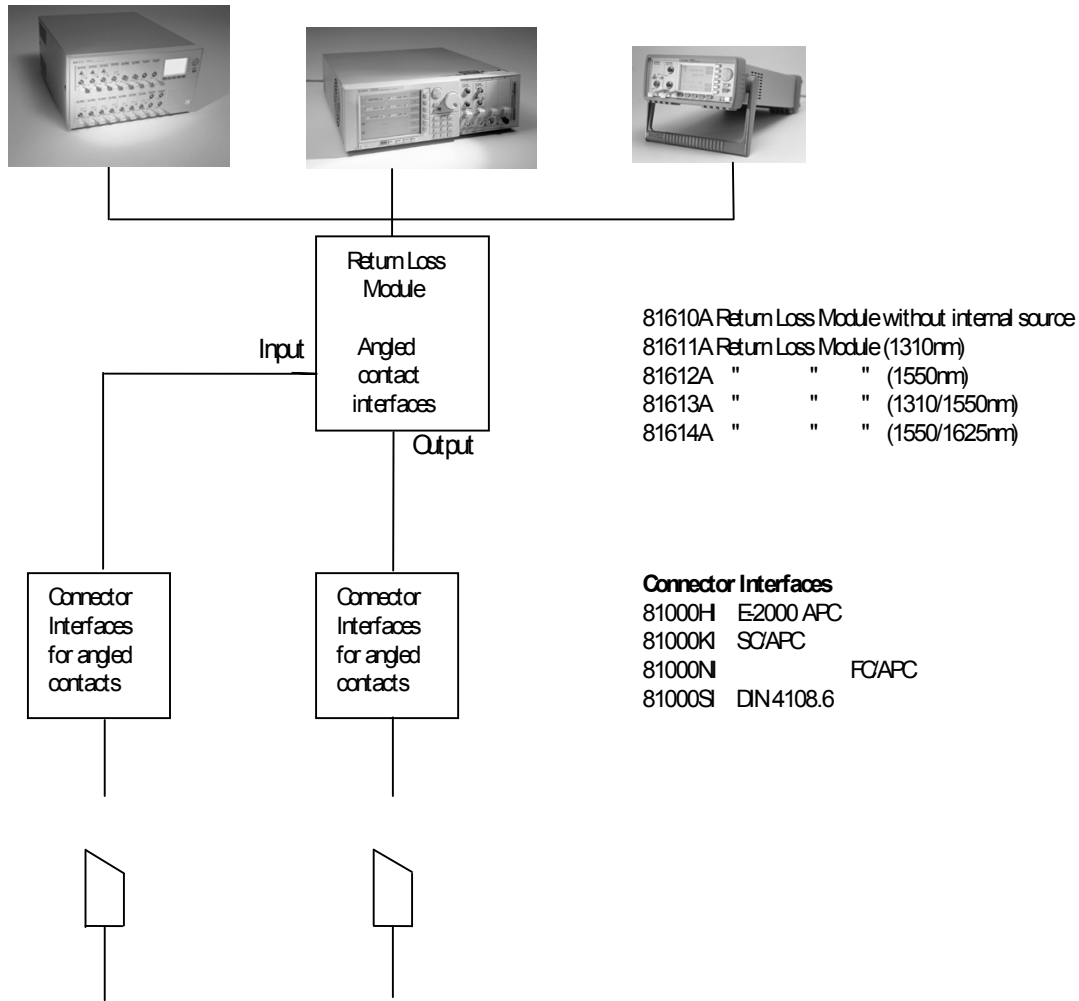

Reference Cable

81610CC Reference Cable – for calibration of all 8161xA Return Loss Modules
 Connectors - DIN4108.6 (connectors to modules) and FC/APC supplied (w/calibrated return loss values)
 An 81000SI connector interface is required to connect this cable to the module.
 This cable is used for calibration only, not for measurements.

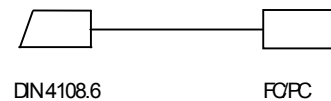

Figure 36 Recommended Connector Interfaces

Specifications

Keysight 81610A/11A/12A/13A/14A Return Loss Modules are produced to the ISO 9001 international quality system standard as part of Keysight Technologies's commitment to continually increasing customer satisfaction through improved quality control.

Specifications describe the modules' warranted performance. Supplementary performance characteristics describe the modules' non-warranted typical performance.

Because of the modular nature of the instrument, these performance specifications apply to these modules rather than the mainframe unit.

Definition of Terms

This section defines terms that are used both in this chapter and .

Generally, all specifications apply for the given environmental conditions and after warmup time.

Measurement principles are indicated. Alternative measurement principles of equal value are also acceptable.

Return Loss

The ratio between incident optical power P_{in} and reflected optical power P_{back} of an optical component is called return loss, symbol RL , expressed in dB :

$$RL[\text{dB}] = 10 \log \frac{P_{in}}{P_{back}} = P_{in}[\text{dBm}] - P_{back}[\text{dBm}]$$

Return loss of the reference cable

The return loss of the reference cable is defined as the return loss caused by the reflection from the surface of its straight end (reference surface).

Conditions: The reference surface shall never be brought into physical contact with anything, to avoid mechanical damage (no physical connection!).
Temperature and wavelength ranges as specified.

NOTE

The return loss of the reference cable is defined by the transition from the reference surface to air.

Dynamic Range

The range of return losses for which the specified uncertainties apply, with a lower limit of 0 dB (corresponds to an upper limit of 100 % reflection).

Conditions: As specified.

External Input Power Range

The range of external input power levels for which the specified uncertainties apply.

External Input Damage Power

The maximum power level that can be applied to the input port without permanent change of the return loss meter characteristics.

Center Wavelength

The center wavelength is defined as the spectral center of gravity. For a Fabry-Perot type laser source with discrete longitudinal modes, this definition can be expressed as:

$$\lambda_c = \frac{P_i \lambda_i}{\sum P_i}$$

where: P_i = power levels of the individual longitudinal lines
 λ_i = wavelengths of the individual longitudinal lines

Conditions: Warmup time as specified, temperature as specified.

Wavelength Range

The range of external input wavelengths for which the specified uncertainties apply.

Relative Uncertainty

The maximum difference between a change of measured return loss and the correspondent change of actual return loss. Symbol ΔR_{rel} , expressed in dB :

$$\Delta R_{rel} = (R_x' - R_0') - (R_x - R_0) \quad (\text{all quantities expressed in dB})$$

where R_x is the actual return loss, R_0 is an arbitrary return loss reference, and apostrophe (') indicates measured quantities.

The relative uncertainty includes receiver nonlinearity, receiver polarization sensitivity, and uncertainty of input power monitoring.

Conditions: “Termination calibration” prior to measurement. Constant ambient temperature, constant wavelength and source polarization state. Other conditions as specified.

NOTE

This parameter is needed to determine the accuracy of return loss *changes*, for example caused by adjusting an optical component.

Total Uncertainty

The maximum difference between measured return loss and actual return loss. Symbol ΔR_{total} , expressed in dB.

$$\Delta R_{total} = R_x' - R_x \quad (\text{all quantities expressed in dB})$$

where R_x' is the measured return loss, R_x the actual return loss.

The total uncertainty includes receiver nonlinearity, receiver polarization sensitivity, uncertainty of input power monitoring, insertion loss uncertainty of the reference cable, and reflection uncertainty of the reference cable.

Conditions: Full calibration (reflectance calibration, termination calibration, and front panel delta) prior to measurement, constant ambient temperature, measurement at wavelengths for which the calibration was carried out, and constant source polarization state. Other conditions as specified.

NOTE

Wavelength dependent measurements of the actual return loss can be performed by fully calibrating at each needed wavelength and using the corresponding calibration settings for each measurement.

Plug & Play

The operation mode at which the factory settings for parasitics (no termination calibration) and reference value (no reflectance calibration) and a front panel delta of zero (no front panel calibration) are used.

Conditions: Measurement patchcord connectors in perfect optical condition. Length of measurement patchcord and connector return loss as specified. Other conditions as specified.

Return Loss Module Specifications

All modules require angled contact (8°) at input and output connectors

Table 2 Return Loss Module Specifications

	Keysight 81610A	
Internal source	external input only ^[1]	
Sensor element	InGaAs	
Fiber type	Standard single-mode 9 / 125 μm	
External input	max input power:	10 dBm
	min input power:	0 dBm
	damage input power:	16 dBm
Wavelength range for external input	1250 nm to 1640 nm	
Dynamic Range	70 dB	
Relative uncertainty of Return Loss (RL)^[2]	with broadband source	with Keysight FP sources
RL ≤ 55 dB	< ± 0.25 dB	typ. < ± 0.5 dB
RL ≤ 60 dB	< ± 0.3 dB	typ. < ± 1.0 dB
RL ≤ 65 dB	< ± 0.65 dB	typ. < ± 2.0 dB
RL ≤ 70 dB	< ± 1.7 dB	
Total uncertainty	add ± 0.2 dB	add typ. ± 0.2 dB
Dimensions (H x W x D)	75mm x 32mm x 335mm (2.8" x 1.3" x 13.2")	
Weight	0.6 kg	
Recalibration period	2 years	
Operating temperature	10°C to 40°C	
Humidity	Non-condensing	
Warm-up time^[3]	20 minutes	
<p>^[1] Insertion Loss is in the range of 7dB.</p> <p>^[2] Averaging Time 1 s, calibration prior to measurement, constant temperature, Broadband source: 83438A FP Sources: 81650A, 81651A, 81652A, 81654A with active coherence control Reference Cable 81610CC used for total uncertainty Length of measurement patchcord ≤ 2m, angled connector in optimal optical conditions</p> <p>^[3] Warm-up time 60 minutes if not previously stored at the same temperature.</p>		

Table 3 Reference Cable Specifications

	81610CC Reference Cable
Return Loss	as printed on cable
Return loss uncertainty	± 0.2 dB ^[1]
Wavelengths	1310 and 1550 nm ± 20 nm
^[1] Clean reference reflector in perfect optical condition (Do not use with contact-type connectors).	

NOTE

To connect to Return Loss Modules the cable requires connector interface 81000SI DIN47256.

Return Loss Module Specifications with Internal Source

NOTE

For use with external sources the specifications of the Keysight 81610A Return Loss Module apply.

All modules require angled contact (8°) at input and output connectors

Table 4 Return Loss Module Specifications with Internal Source

	81611A	81612A	Keysight 81613A	81614A
Source	Fabry-Perot Laser (internal)			
Output Power	typ. -4dBm			
Center wavelength ^[1]	1310 nm ± 20 nm typ.	1550 nm ± 20 nm typ.	1310/1550 nm ± 20 nm typ.	1550/1625 nm ± 20 nm typ.
Sensor element	InGaAs			
Fiber type	Standard single-mode 9/125 μm			
Dynamic Range ^[1]	75 dB			
Relative uncertainty of Return Loss (RL)	User Calibration ^[2]		Plug and Play ^[3]	
RL ≤ 55 dB	< ±0.5 dB (typ. < ±0.3 dB)		typ. < ±0.6 dB	
RL ≤ 60 dB	< ±0.6 dB (typ. < ±0.4 dB)		typ. < ±1.5 dB	
RL ≤ 65 dB	< ±0.8 dB (typ. < ±0.5 dB)			
RL ≤ 70 dB	< ±1.9 dB (typ. < ±0.8 dB) ^[4]			
RL ≤ 75 dB	typ. < ±2.0 dB ^[4]			
Total uncertainty	add ±0.2 dB		add typ. ±0.2 dB	
Dimensions (H x W x D)	75 mm x 32 mm x 335 mm (2.8" x 1.3" x 13.2")			
Weight	1 kg			
Recalibration period	2 years			
Operating temperature	10 to 40°C			
Humidity	Non-condensing			
Warm-up time ^[5]	20 minutes			
<p>^[1] At 25°C constant temperature, coherence control on warm-up time after laser turn on >5 min.</p> <p>^[2] Averaging Time 1 s, calibration prior to measurement, constant temperature, coherence control on, warm-up time after laser turn on >5 min length of measurement patchcord ≥ 2m, angled connector in optimal optical condition Reference Cable 81610CC used for total uncertainty.</p> <p>^[3] Factory defaults are set to (no user calibration necessary): length of measurement patchcord ≤ 2 m, return loss of connectors ≥70 dB</p> <p>^[4] For measurements performed immediately after calibration</p> <p>^[5] Warm-up time 60 minutes if not previously stored at the same temperature.</p>				

Performance Tests

The procedures in this section test the performance of the instrument. The complete specifications to which the Keysight 81610A Return Loss module, and the Keysight 81610CC Reference Cable, are tested are given in “*Specifications*” on page 49. The Return Loss of Keysight 81610CC Reference Cable is printed on the cable. All tests can be performed without access to the interior of the instrument. Where not otherwise specified, the performance tests refer to tests carried out with Diamond HMS -10 connectors.

Equipment Required

Equipment required for the performance test is listed below. Any equipment that satisfies the critical specifications may be substituted for the recommended models.

Instrument/Accessory	Recommended Model	81610A	81610CC	81611A/12A/ 13A/14A	Required Characteristics	Alternative Models
Multimeter Mainframe	8163A/B	x	x	x		8164A/B
Multimeter Mainframe	8163A/B	–	x	–		8164A/B
ASE Source	83438A	x	–	–		
Power Meter Standard	81634A	x	x	x		81633A
Optical Attenuator	8156A #201	x	–	–		
Optical Attenuator	8156A #101	–	x	–		
Special Optical Attenuator	8156A Special	–	–	x		
Polarization Controller	11896A #020 #021	–	x	x		
Dual Laser Source	81654A	–	x	–		
Reference Cable	81610CC (1 ea)	x	DUT	x		
Singlemode Fibers	81113PC (1 ea)	x	x	–		
	81113SC (1 ea)	x	–	–		
Connector Interfaces	81000FI	x (2 ea)	x (4 ea)	x		
	81000SI	x (4 ea)	x (2 ea)	x		
Connector Feedthrough	1005-0256	–	–	x		
Plastic Cap	5040-9351 (2 ea)	x	–			

Test Record

Results of the performance test may be tabulated on the Test Record provided after the test procedures. It is recommended that you fill out the Test Record and refer to it while doing the test. Since the test limits and setup information are printed on the Test Record for easy reference, you can also use the record as an abbreviated test procedure (if you are already familiar with the test procedures). You can also use the test record as a permanent record and it may be reproduced without written permission from Keysight Technologies.

Test Failure

If the Keysight 81610A/13A Return Loss module fails any performance test, return the instrument to the nearest Keysight Technologies Sales/Service Office for repair. The 81610CC Reference Cable may be recalibrated using the procedure given in [“Calibrating the 81610CC Reference Cable” on page 72](#); a repair is not possible.

Instrument Specification

Specifications are the performance characteristics of the instrument that are certified. These specifications, listed in *“Specifications” on page 49*, are the performance standards or limits against which the Keysight 81610A/13A Return Loss module can be tested. *“Specifications” on page 49* also lists some supplemental characteristics of the Keysight 81610A/13A Return Loss module. Supplemental characteristics should be considered as additional information.

Any changes in the specifications due to manufacturing changes, design, or traceability to the National Institute of Standards and Technology (NIST), are covered in a manual change supplement, or revised manual. Such specifications supersede any that were previously published.

Performance Test Instructions

CAUTION

Do not connect a Keysight 81000BR Reference Reflector directly to the Keysight 81610A/13A Return Loss module.

NOTE

Make sure that all optical connections of the test setups given in the procedure are dry and clean. **DO NOT USE INDEX MATCHING OIL.** For cleaning, use the cleaning instructions given in “*Cleaning Information*” on page 87.

Keysight 81610A: Relative Uncertainty of Return Loss and Dynamic Range Test

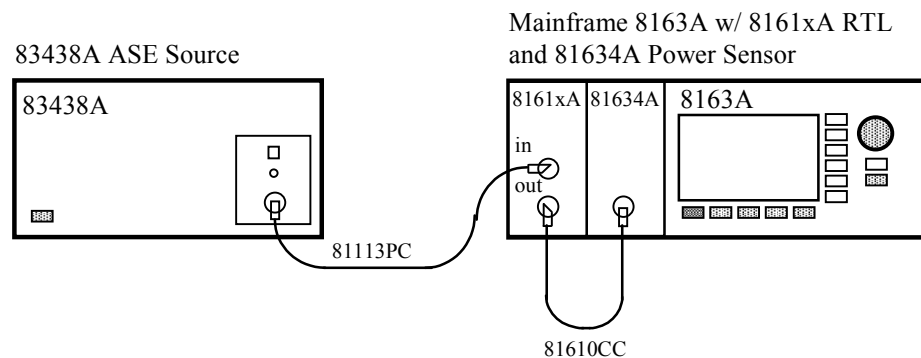

Figure 37 Relative Uncertainty of Return Loss - Calibration Setup

The maximum range of the Return Loss meter is significantly affected by all parasitic reflections and backscatter returned to the optical output of the Return Loss meter.

To minimize these effects, it is essential to use clean connectors, and to minimize the fiber lengths and the number of optical connections used in the measurement setup.

- 1 Make sure that all cable connectors are clean.

- 2 Setup the equipment as shown in [Figure 37](#).
- 3 Press [Preset] on the mainframe
- 4 Zero the Return Loss meter and the Power meter.
- 5 Enable the ASE source, and allow 20 minutes for it to stabilize.
- 6 At the Power meter:
 - a Set the averaging time [*Av Time*] to 1 s
 - b Set the wavelength [λ] to the wavelength of the ASE source.
 - c Set [Pwr unit] to *<dB>*.
- 7 At the Return Loss meter:
 - a Set the averaging time [*Av Time*] to 1 s
 - b Set the wavelength [λ] to the wavelength of the ASE source.
 - c Enter the Return Loss Reference value [*RLref*] of the 81610CC reference cable for this wavelength. Note this value in the Test Record as RLref
 - d Press [RefCal] to calibrate the Return Loss module at reference condition.
- 8 At the Power meter, press [Disp → Ref].
The Power meter should now read 0.0 dB.

- 9 Setup the equipment as shown in **Figure 38**. Use an optical attenuator with angled connectors, and connect the angled connector of the 81610CC Reference Cable to the output of the attenuator.

The optical cable from the laser source, and the optical cables to and from the 8156A Attenuator, must be fixed to the table to ensure minimal cable movement during the tests.

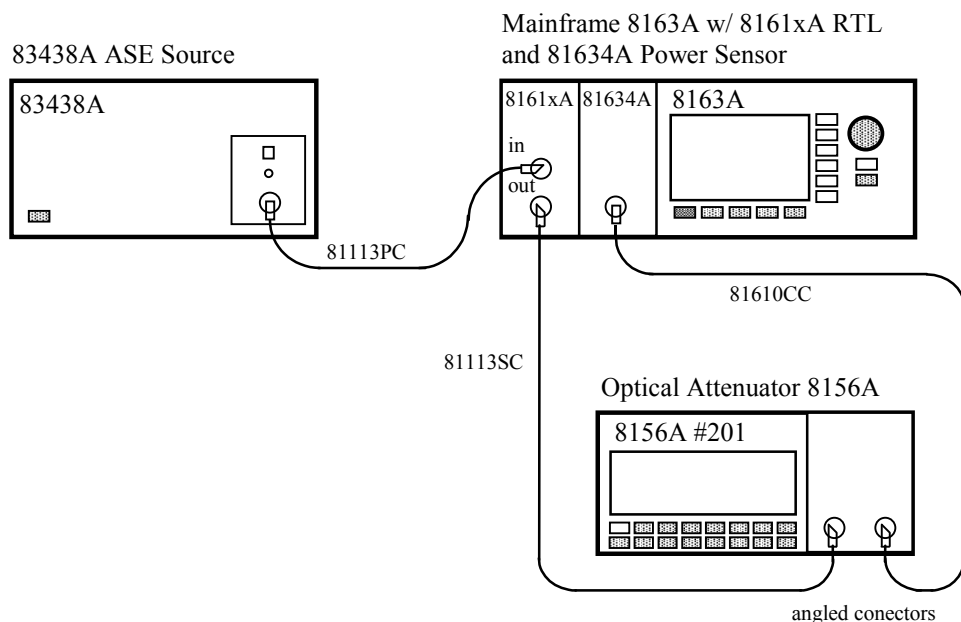

Figure 38 Relative Uncertainty of Return Loss - Performance Test Setup

NOTE

To ensure traceability, use the 81610CC Reference Cable for calibration measurements.

Do not use the 81610CC Reference Cable for measurements on a Device Under Test. Instead, use a measurement patchcord.

CAUTION

It is important to maintain the quality of the straight connector end of the 81610CC Reference Cable.

Never add another connector to the straight end of the 81610CC Reference Cable, since a physical connection is made.

When the straight end of the 81610CC Reference Cable is connected to the 81634A Power Sensor module, no physical connection is made, so there should be no degradation of connector quality.

10 Enter the power [P] reading on the Power meter as [$FP\ Delta$] on the Return Loss meter.

Make sure you enter the sign of this value correctly.

11 At the optical attenuator:

- a** Set 'Attenuation' to 60.0 dB
- b** Set 'Wavelength' to the wavelength of the ASE source
- c** Enable the attenuator.

12 At the Return Loss meter, press [TermCal] to calibrate the Return Loss module at termination condition.

13 At the optical attenuator, set the 'Attenuation' to 0.0 dB

The measured Return Loss should now be identical to the [$RLref$] value entered at **step 7**.

14 Note this return loss value in the Test Record.

15 At the optical attenuator, increase the 'Attenuation' setting until the Return Loss reading matches the next value in the Test Record. Note this 'Attenuation' setting in the Test Record as 'Actual Attenuation'.

16 Repeat steps 13 and 14 for each value in the test record.

17 For each Return Loss reading, calculate the result by:

- a** Calculating the Effective Attenuation by multiplying the Actual Attenuation by 2.
- b** Subtracting the $RLref$ value from the Return Loss value, then subtracting the Effective Attenuation value.

An example follows:

Example for Keysight 81610A Return Loss module

Actual Return Loss Reading [dB]	Actual Attenuation [dB]	Subtract		Result [dB]
		Effective Attenuation [dB]	RLref [dB]	
RL	AA	EA=2AA	RLref	= RL - EA - RLref
14.8	0.00	0.0	14.81	+0.0
20.0	2.55	5.1		+0.1
25.0	5.10	10.2		+0.0
30.0	7.60	15.2		+0.0
35.0	10.10	20.2		+0.0
40.0	12.55	25.1		+0.1
45.0	15.10	30.2		+0.0
50.0	17.55	35.1		+0.1
52.5	18.55	37.7		+0.0
55.0	20.05	40.1		+0.1
57.5	21.25	42.5		+0.2
60.0	22.50	45.0		+0.2
62.5	23.70	47.4		+0.3
65.0	24.90	49.8		+0.4

Keysight 81610A/13A: Relative Uncertainty of Return Loss and Dynamic Range

The maximum return loss range at the Return Loss Meter is significantly affected by all parasitic reflections and backscatter returned to the optical output of the Return Loss Meter.

To minimize these effects, it is essential to use clean connectors, and to minimize the fiber lengths and the number of optical connections used in the measurement setup.

- 1 Make sure that all connectors are clean.
- 2 Setup the equipment as shown in [Figure 39](#).
- 3 Press [Preset] on the mainframe.

Mainframe 8163A w/ 8161xA RTL
and 81634A Power Sensor

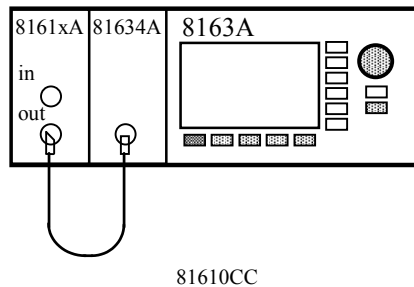

Figure 39 Relative Uncertainty of Return Loss - Calibration Setup

NOTE To ensure traceability, use the 81610CC Reference Cable for calibration measurements. Do not use the 81610CC Reference Cable for measurements on a Device Under Test. Instead, use a measurement patchcord.

CAUTION

It is important to maintain the quality of the straight connector end of the 81610CC Reference Cable. Never add another connector to the straight end of the 81610CC Reference Cable, since a physical connection is made. When the straight end of the 81610CC Reference Cable is connected to the 81634A Power Sensor module, no physical connection is made, so there should be no degradation of connector quality.

- 4 Zero the return loss meter as well as the power meter.
- 5 Enable the internal laser source of the return loss module and allow 20min for it to stabilize.

- 6 At the Power meter:
 - a Set the averaging time [Av Time] to 1s
 - b Set the wavelength [l] to the wavelength of the RTL source.
 - c Set [Pwr unit] to <dB>.
- 7 At the return loss meter:
 - a Set the averaging time [Av Time] to 1s.
 - b Enter the Return Loss Reference value RL_{ref} of the 81610CC reference cable for this wavelength. Note this value in the Test Record as RL_{ref} .
 - c Press [RefCal] to calibrate the Return Loss module at reference condition.
- 8 At the powermeter press [Disp@Ref]. The Power meter should now read 0.0dB.
- 9 Setup the equipment as shown in figure D-4. Use an special pigtailed optical attenuator w/ an angled input and straight output connector and connect the angled connector to the output of the 81611-14A return loss module. The output fiber of the optical attenuator is connected to the input of the powermeter. All optical cables used in this setup should be fixed.

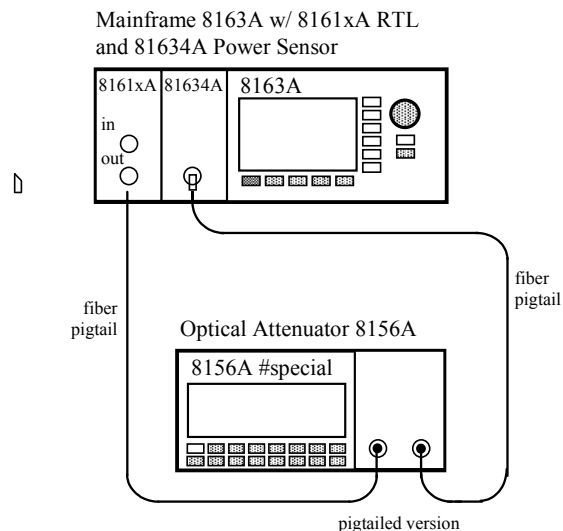

Figure 40 Relative Uncertainty of Return Loss - Performance Test Setup

- 10 Enter the power [P] reading on the Power meter as [FPDelta] on the Return Loss meter. Make sure you enter the sign of this value correctly.
- 11 At the optical attenuator:
 - a Set 'Attenuation' to 60.0dB.
 - b Set 'Wavelength' to the wavelength of the RTL source.
 - c Enable the attenuator.

- 12 At the Return Loss meter, press [TermCal] in order to calibrate the Return Loss module at termination condition.
- 13 At the optical attenuator, set the 'Attenuation' to 0.0dB. The measured Return Loss should now be identical to the RLref value entered at step 7.b).
- 14 Note this return loss value in the Test Record.
- 15 At the powermeter press [Disp®Ref]. The Power meter should now read 0.0dB.
- 16 At the optical attenuator, increase the 'Attenuation' setting until the Return Loss reading matches the next value in the Test Record. Note the value on the power meter in the Test Record as 'Actual Powermeter Reading'.
- 17 Repeat step 15) and 16) each value in the test record.
- 18 Now, determine once the maximum polarization uncertainty for this setup. Connect the equipment as shown in figure D-5.

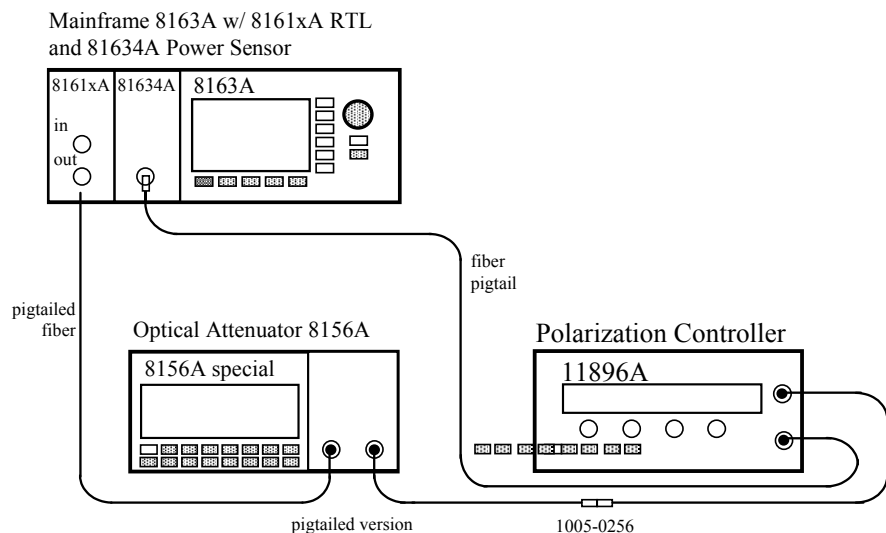

Figure 41 Relative Uncertainty of Polarization

- 19 Adjust the attenuation of the attenuator until the displayed return loss value is about 25dB.
- 20 At the polarization controller:
 - a Set the scan rate to 3
 - b Press the 'autoscan' button to start scrambling the polarization.
- 21 At the return loss module:
 - a Set the averaging time [Averaging time] to 50ms.
 - b Set [Data Points] to 1000.
 - c Select [MinMax mode], select the [continuous] mode.

- d** Fix the cables on the table and ensure no movement of the fibers.
- e** Select [Reset MinMax]
- f** Wait 50 seconds.
- g** Note the DP reading on the return loss module as the PDL value into the test record.

22 For each Return Loss reading, calculate the result by:

- a** Calculating the Effective Attenuation by multiplying the Actual Powermeter Reading (APR) by 2.
- b** Calculate the total attenuation by totaling the effective attenuations up to the current reading.
- c** To calculate the relative uncertainty of return loss, subtract the RLref and the TA value from the RL value.
- d** Calculate the revised specification by subtracting the PDL uncertainty from the specifications.

For reference, see example below.

Actual Return Loss Reading [dB]	Actual Powermeter Reading [dB]	Subtract			Result	rev Spec	PDL	Spec
		Effective Attenuation [dB]	Total Attenuation [dB]	RLref [dB]	[dB]	[dB]		
RL	APR	EA = 2*APR	TA = $\sum_{i \leq n} EA_i$	RLref	= RL - TA -RLref	Spec-PDL	max. PDL [dB]	[dB]
14.8	0.00	0.00	0.00		-0.01	<±0.38		<±0.5
20.0	-2.55	-5.10	-5.10		+0.09	<±0.38		<±0.5
25.0	-2.55	-5.10	-10.20		-0.01	<±0.38		<±0.5
30.0	-2.50	-5.10	-15.20		-0.01	<±0.38		<±0.5
35.0	-2.50	-5.00	-20.20		-0.01	<±0.38		<±0.5
40.0	-2.45	-4.90	-25.10		+0.09	<±0.38		<±0.5
45.0	-2.55	-5.10	-30.20		-0.01	<±0.38		<±0.5
50.0	-2.45	-4.90	-35.10	14.81	-0.09	<±0.38	0.12	<±0.5
52.5	-1.30	-2.60	-37.70		-0.01	<±0.38		<±0.5
55.0	-1.20	-2.40	-40.10		+0.09	<±0.38		<±0.5
57.5	-1.20	-2.40	-42.50		+0.19	<±0.48		<±0.6
60.0	-1.25	-2.50	-45.00		+0.19	<±0.48		<±0.6
62.5	-1.20	-2.40	-47.40		+0.29	<±0.68		<±0.8
65.0	-1.20	-2.40	-49.80		+0.39	<±0.68		<±0.8
67.5	-1.25	-2.40	-52.30		+0.39	<±1.78		<±1.9
70.0	-1.00	-2.00	-54.30		+0.89	<±1.78		<±1.9

Calibrating the 81610CC Reference Cable

The 81610CC Reference Cable may be recalibrated using this procedure. Repair is not possible.

- 1 Make sure that all cable connectors are clean.
- 2 Setup the equipment as shown in [Figure 42](#).

Make sure that the output port of the Attenuator has a straight connector. Clean this connector very carefully, and connect it to the straight end of the 81610CC Reference Cable.

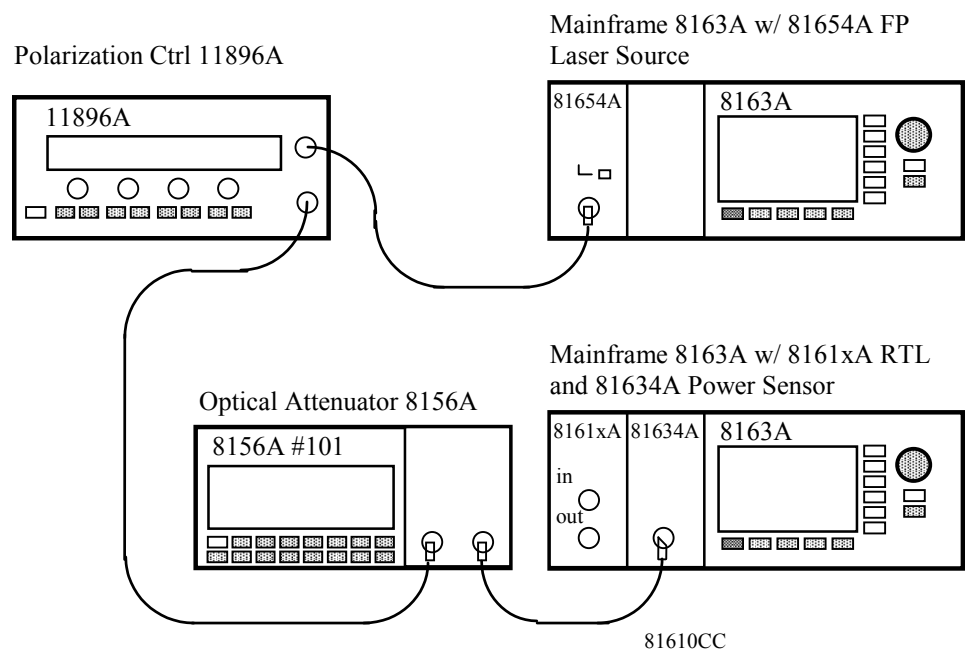

Figure 42 81610CC Reference Cable - Initial Setup

- 3 At the Laser Source module,
 - a Enable the Laser Source
 - b Set the wavelength [λ] to 1310 nm
 - c Press [*Mod Src*] and select *<Coherence Ctrl>* to modulate the source using coherence control.

NOTE

Allow the Laser Source to stabilize for at least 20 minutes.

- 4 At the Attenuator, set the 'Wavelength' to the wavelength of the Laser source.
- 5 At the Power Sensor module,
 - a Set the wavelength [λ] to the wavelength of the Laser Source.
 - b Set [Pwr unit] to $\langle dB \rangle$.
- 6 At the Return Loss module,
 - a Make sure [FP Delta] is set to 0.00 dB
 - b Make sure [RL ref] is set to 0.00 dB
 - c Set the averaging time [Av Time] to 10 s
 - d Set $\langle Source\ wavelenth \rangle$ to External.
- 7 Turn on the 11896A Polarization Controller.
 - a Set the 'Scan Rate' to 8
 - b Press the 'Autoscan' button to begin scrambling the polarization states.
- 8 Enable the Attenuator, and set the 'Attenuation' such that the Power Sensor shows a power [P] reading of exactly -20.0000 dB
- 9 Moving the cable as little as possible, disconnect the 81610CC Reference Cable from the Power Sensor module, and connect it to the output of the Return Loss module as shown in [Figure 43](#)

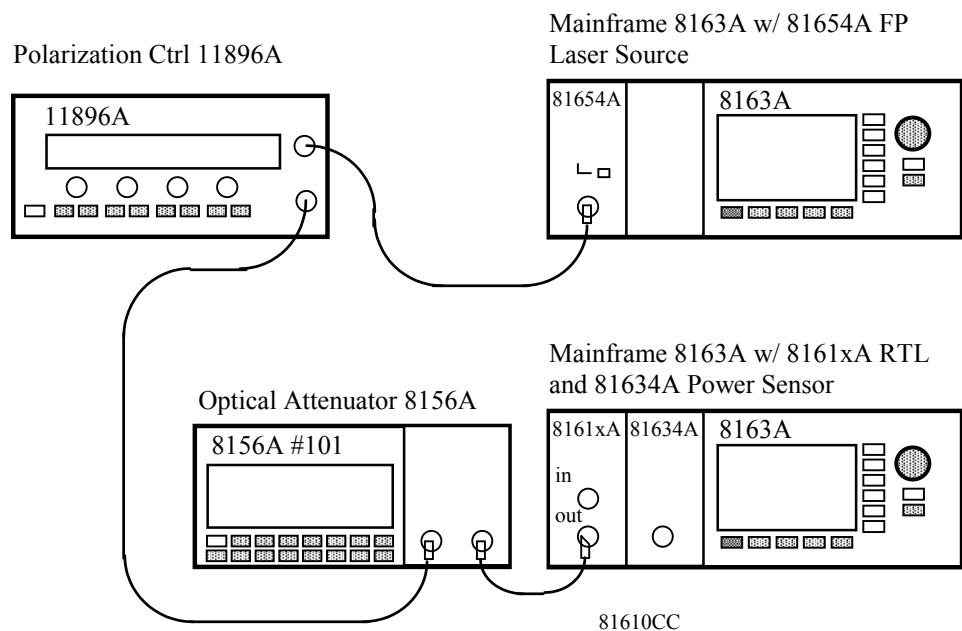

Figure 43 81610CC Reference Cable - Setting the Calibration Reference

10 At the Return Loss module, press [RefCal].

11 Disconnect the 81610CC Reference Cable from the Attenuator, and connect the straight end to the Power Sensor module, as shown in **Figure 44**

Use an additional 81113PC patchcord to connect the the straight Attenuator output to the angled Return Loss module input.

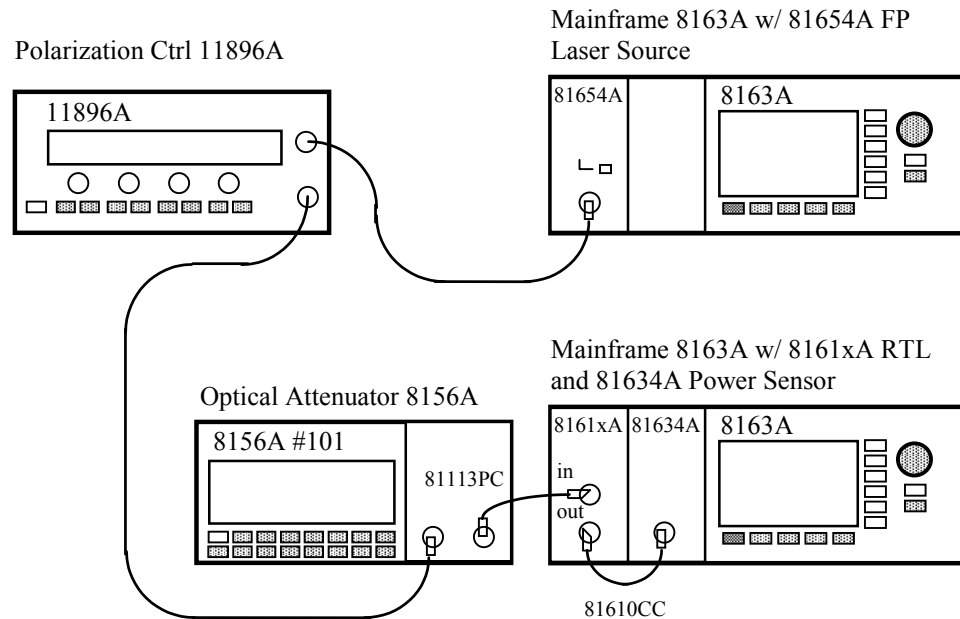

Figure 44 81610CC Reference Cable - Adjusting Input Power to 0.0 dB Return Loss

12 Set the 'Attenuation' such that the Power Sensor shows a power [P] reading of exactly -20.0000 dB

13 At the Return Loss module,

- a** Press [Menu], scroll to <Show calibration>, and press [Ok]
- b** On the 'Calibration parameters' page labelled 'Return Loss Diode', note the values of [Ref] and [$Meas$].

14 Calculate the Return Loss, RL, for this wavelength

$$RL @ \text{_____ nm} = Ref - Meas$$

15 Repeat steps 1 to 14 for the upper wavelength, that is 1550 nm

NOTE

If the return loss of the 81610CC Reference Cable differs from the value printed on the cable, use the newly measured return loss value as the Reference Reflectance for the wavelength at which it was measured.

Performance Test for the Keysight 81610A

Page 1 of 3

Model	Keysight 81610A Return Loss module	Date	_____
Serial No.	_____	Ambient Temperature	_____ °C
Options	_____	Relative Humidity	_____ %
Firmware Rev.	_____	Line Frequency	_____ Hz
Test Facility	_____	Customer	_____
Performed by	_____	Report No	_____

Special Notes

Performance Test for the Keysight 81610A

Test Equipment Used

Page 2 of 3

	Description	Model No.	Trace No	Cal. Due Date
1a1	Lightwave Multimeter (Std.)	8163A	_____	_____
1a2	Lightwave Multimeter	8163A	_____	_____
1b	TLS Mainframe	8164A	_____	_____
2	Sensor Module	81634A	_____	_____
3	ASE Source	83438A	_____	_____
4	Optical Attenuator	8156A #201	_____	_____
5	_____	_____	_____	_____
6	_____	_____	_____	_____
7	_____	_____	_____	_____
8	_____	_____	_____	_____
9	_____	_____	_____	_____
10	_____	_____	_____	_____
11	_____	_____	_____	_____
12	_____	_____	_____	_____
13	_____	_____	_____	_____
14	_____	_____	_____	_____
15	_____	_____	_____	_____

Accessories	#	Product	#	Product	#	Product
Calibration Cable	1	81610CC				
Singemode Fibers	1	81113PC	1	81113SC		
Connector Interfaces	2	81000FI	4	81000SI		

Performance Test for the Keysight 81610A

Page 3 of 3

Model: Keysight 81610A Return Loss module

Report No _____

Date _____

Test Number	Test Description				Min. Spec.	Result [dB]	Max. Spec.	Measurement Uncertainty
I	Relative Uncertainty of RL [dB]							
	RL	AA	EA = 2AA	RLref		= RL - EA - RL-ref		
	15.0				-0.25<		<+0.25	
	20.0				-0.25<		<+0.25	
	25.0				-0.25<		<+0.25	
	30.0				-0.25<		<+0.25	
	35.0				-0.25<		<+0.25	
	40.0				-0.25<		<+0.25	
	45.0				-0.25<		<+0.25	
	50.0				-0.25<		<+0.25	
	52.5				-0.25<		<+0.25	
	55.0				-0.25<		<+0.25	
	57.5				-0.50<		<+0.50	
	60.0				-0.50<		<+0.50	
	62.5				-1.00<		<+1.00	
	65.0				-1.00<		<+1.00	

Performance Test for the Keysight 81613A

Page 1 of 3

Model	Keysight 81613A Return Loss module	Date	_____
Serial No.	_____	Ambient Temperature	_____ °C
Options	_____	Relative Humidity	_____ %
Firmware Rev.	_____	Line Frequency	_____ Hz
Test Facility	_____	Customer	_____
Performed by	_____	Report No	_____

Special Notes

Performance Test for the Keysight 81613A

Test Equipment Used

Page 2 of 3

	Description	Model No.	Trace No	Cal. Due Date
1a1	Lightwave Multimeter (Std.)	8163A	_____	_____
1a2	Lightwave Multimeter	8163A	_____	_____
1b	TLS Mainframe	8164A	_____	_____
2	Sensor Module	81634A	_____	_____
3	Optical Attenuator	8156A special	_____	_____
4	Polarization Controller	11896A	_____	_____
5	_____	_____	_____	_____
6	_____	_____	_____	_____
7	_____	_____	_____	_____
8	_____	_____	_____	_____
9	_____	_____	_____	_____
10	_____	_____	_____	_____
11	_____	_____	_____	_____
12	_____	_____	_____	_____
13	_____	_____	_____	_____
14	_____	_____	_____	_____
15	_____	_____	_____	_____

Accessories	#	Product	#	Product	#	Product
Calibration Cable	1	81610CC				
Fiber Feedthrough	1	1005-0256				
Connector Interfaces	2	81000SI	1	81000FI		

Performance Test for the Keysight 81613A

Page 3 of 3

Model: **Keysight 81613A Return Loss module** Report No _____ Date _____

Test Number	Test Description					Result [dB]	Revised Spec.	PDL [dB]	Spec.	Measurement Uncertainty
I	Relative Uncertainty of RL [dB]									
	RL	APR	EA = 2APR	$\sum_{EA_i}^{EA_n}$ i ≤ n	RLref	= RL - $\sum_{EA_i}^{EA_n}$ - RLref	= RL - EA - RL-ref			
	15.0								<+0.5	
	20.0								<+0.5	
	25.0								<+0.5	
	30.0								<+0.5	
	35.0								<+0.5	
	40.0								<+0.5	
	45.0								<+0.5	
	50.0								<+0.5	
	52.5								<+0.5	
	55.0								<+0.5	
	57.5								<+0.6	
	60.0								<+0.6	
	62.5								<+0.8	
	65.0								<+0.8	
	67.5								<+1.9	
	70.0								<+1.9	

Calibration of 81610CC Reference Cable

Test Equipment Used

Page 2 of 3

	Description	Model No.	Trace No	Cal. Due Date
1a1	Lightwave Multimeter (Std.)	8163A	_____	_____
1a2	Lightwave Multimeter	8163A	_____	_____
1b	TLS Mainframe	8164A	_____	_____
2	Sensor Module	81634A	_____	_____
3	Dual FP Laser Source	81654A	_____	_____
4	Optical Attenuator	8156A #101	_____	_____
5	Polarization Controller	11896A #020, #021	_____	_____
6	_____	_____	_____	_____
7	_____	_____	_____	_____
8	_____	_____	_____	_____
9	_____	_____	_____	_____
10	_____	_____	_____	_____
11	_____	_____	_____	_____
12	_____	_____	_____	_____
13	_____	_____	_____	_____
14	_____	_____	_____	_____
15	_____	_____	_____	_____

Accessories	#	Product	#	Product	#	Product
Singemode Fibers	1	81113PC				
Connector Interfaces	4	81000FI	2	81000SI		

Calibration of 81610CC Reference Cable

Page 3 of 3

Model: 81610CC Reference Cable

Report No _____

Date _____

Test Number	Test Description			Min. Spec.	Result [dB]	Max. Spec.	Measurement Uncertainty
II	Reference Reflectance						
	Wave-length	Ref	Meas		= Ref - Meas		
	1310 nm						± 0.20 dB
	1550 nm						± 0.20 dB

Cleaning Information

The following Cleaning Information contains some general safety precautions, which must be observed during all phases of cleaning. Consult your specific optical device manuals or guides for full information on safety matters.

Please try, whenever possible, to use physically contacting connectors, and dry connections. Clean the connectors, interfaces, and bushings carefully after use.

If you are unsure of the correct cleaning procedure for your optical device, we recommend that you first try cleaning a dummy or test device.

Keysight Technologies assume no liability for the customer's failure to comply with these requirements.

Cleaning Instructions for this Instrument

This Cleaning Information applies to a number of different types of Optical Equipment.

“[How to clean instruments with a physical contact interface](#)” on page 101 is particularly relevant to this module.

Safety Precautions

Please follow the following safety rules:

- Do not remove instrument covers when operating.
- Ensure that the instrument is switched off throughout the cleaning procedures.
- Use of controls or adjustments or performance of procedures other than those specified may result in hazardous radiation exposure.
- Make sure that you disable all sources when you are cleaning any optical interfaces.
- Under no circumstances look into the end of an optical device attached to optical outputs when the device is operational. The laser radiation is not visible to the human eye, but it can seriously damage your eyesight.
- To prevent electrical shock, disconnect the instrument from the mains before cleaning. Use a dry cloth, or one slightly dampened with water, to clean the external case parts. Do not attempt to clean internally.
- Do not install parts or perform any unauthorized modification to optical devices.
- Refer servicing only to qualified and authorized personnel.

Why is it important to clean optical devices?

In transmission links optical fiber cores are about 9 μm (0.00035") in diameter. Dust and other particles, however, can range from tenths to hundredths of microns in diameter. Their comparative size means that they can cover a part of the end of a fiber core, and as a result will reduce the performance of your system.

Furthermore, the power density may burn dust into the fiber and cause additional damage (for example, 0 dBm optical power in a single mode fiber causes a power density of approximately 16 million W/m^2). If this happens, measurements become inaccurate and non-repeatable.

Cleaning is, therefore, an essential yet difficult task. Unfortunately, when comparing most published cleaning recommendations, you will discover that they contain several inconsistencies. In this section, we want to suggest ways to help you clean your various optical devices, and thus significantly improve the accuracy and repeatability of your lightwave measurements.

What do I need for proper cleaning?

Some **Standard Cleaning Equipment** is necessary for cleaning your instrument. For certain cleaning procedures, you may also require certain **Additional Cleaning Equipment**.

Standard Cleaning Equipment

Before you can start your cleaning procedure you need the following standard equipment:

- **Dust and shutter caps**
- **Isopropyl alcohol**
- **Cotton swabs**
- **Soft tissues**
- **Pipe cleaner**
- **Compressed air**

Dust and shutter caps

All of Keysight Technologies' lightwave instruments are delivered with either laser shutter caps or dust caps on the lightwave adapter. Any cables come with covers to protect the cable ends from damage or contamination.

We suggest these protective coverings should be kept on the equipment at all times, except when your optical device is in use. Be careful when replacing dust caps after use. Do not press the bottom of the cap onto the fiber too hard, as any dust in the cap can scratch or pollute your fiber surface.

If you need further dust caps, please contact your nearest Keysight Technologies sales office.

Isopropyl alcohol

This solvent is usually available from any local pharmaceutical supplier or chemist's shop.

If you use isopropyl alcohol to clean your optical device, do not immediately dry the surface with compressed air (except when you are cleaning very sensitive optical devices). This is because the dust and the dirt is solved and will leave behind filmy deposits after the alcohol is evaporated. You should therefore first remove the alcohol and the dust with a soft tissue, and then use compressed air to blow away any remaining filaments.

If possible avoid using denatured alcohol containing additives. Instead, apply alcohol used for medical purposes.

Never drink this alcohol, as it may seriously damage to your health.

Do not use any other solvents, as some may damage plastic materials and claddings. Acetone, for example, will dissolve the epoxy used with fiber optic connectors. To avoid damage, only use isopropyl alcohol.

Cotton swabs

We recommend that you use swabs such as Q-tips or other cotton swabs normally available from local distributors of medical and hygiene products (for example, a supermarket or a chemist's shop). You may be able to obtain various sizes of swab. If this is the case, select the smallest size for your smallest devices.

Ensure that you use natural cotton swabs. Foam swabs will often leave behind filmy deposits after cleaning.

Use care when cleaning, and avoid pressing too hard onto your optical device with the swab. Too much pressure may scratch the surface, and could cause your device to become misaligned. It is advisable to rub gently over the surface using only a small circular movement.

Swabs should be used straight out of the packet, and never used twice. This is because dust and dirt in the atmosphere, or from a first cleaning, may collect on your swab and scratch the surface of your optical device.

Soft tissues

These are available from most stores and distributors of medical and hygiene products such as supermarkets or chemists' shops.

We recommend that you do not use normal cotton tissues, but multi-layered soft tissues made from non-recycled cellulose. Cellulose tissues are very absorbent and softer. Consequently, they will not scratch the surface of your device over time.

Use care when cleaning, and avoid pressing on your optical device with the tissue. Pressing too hard may lead to scratches on the surface or misalignment of your device. Just rub gently over the surface using a small circular movement.

Use only clean, fresh soft tissues and never apply them twice. Any dust and dirt from the air which collects on your tissue, or which has gathered after initial cleaning, may scratch and pollute your optical device.

Pipe cleaner

Pipe cleaners can be purchased from tobacconists, and come in various shapes and sizes. The most suitable one to select for cleaning purposes has soft bristles, which will not produce scratches.

There are many different kinds of pipe cleaner available from tobacco nists.

The best way to use a pipe cleaner is to push it in and out of the device opening (for example, when cleaning an interface). While you are cleaning, you should slowly rotate the pipe cleaner.

Only use pipe cleaners on connector interfaces or on feed through adapters. Do not use them on optical head adapters, as the center of a pipe cleaner is hard metal and can damage the bottom of the adapter.

Your pipe cleaner should be new when you use it. If it has collected any dust or dirt, this can scratch or contaminate your device.

The tip and center of the pipe cleaner are made of metal. Avoid accidentally pressing these metal parts against the inside of the device, as this can cause scratches.

Compressed air

Compressed air can be purchased from any laboratory supplier.

It is essential that your compressed air is free of dust, water and oil. Only use clean, dry air. If not, this can lead to filmy deposits or scratches on the surface of your connector. This will reduce the performance of your transmission system.

When spraying compressed air, hold the can upright. If the can is held at a slant, propellant could escape and dirty your optical device. First spray into the air, as the initial stream of compressed air could contain some condensation or propellant. Such condensation leaves behind a filmy deposit.

Please be friendly to your environment and use a CFC-free aerosol.

Additional Cleaning Equipment

Some Cleaning Procedures need the following equipment, which is not required to clean each instrument:

- Microscope with a magnification range about 50X up to 300X
- Ultrasonic bath
- Warm water and liquid soap
- Premoistened cleaning wipes
- Polymer film
- Infrared Sensor Card

Microscope with a magnification range about 50X up to 300X

A microscope can be found in most photography stores, or can be obtained through or specialist mail order companies. Special fiber-scopes are available from suppliers of splicing equipment.

Ideally, the light source on your microscope should be very flexible. This will allow you to examine your device closely and from different angles.

A microscope helps you to estimate the type and degree of dirt on your device. You can use a microscope to choose an appropriate cleaning method, and then to examine the results. You can also use your microscope to judge whether your optical device (such as a connector) is severely scratched and is, therefore, causing inaccurate measurements.

Ultrasonic bath

Ultrasonic baths are also available from photography or laboratory suppliers or specialist mail order companies.

An ultrasonic bath will gently remove fat and other stubborn dirt from your optical devices. This helps increase the life span of the optical devices.

Only use isopropyl alcohol in your ultrasonic bath, as other solvents may cause damage.

Warm water and liquid soap

Only use water if you are sure that there is no other way of cleaning your optical device without causing corrosion or damage. Do not use hot water, as this may cause mechanical stress, which can damage your optical device.

Ensure that your liquid soap has no abrasive properties or perfume in it. You should also avoid normal washing up liquid, as it can cover your device in an iridescent film after it has been air dried.

Some lenses and mirrors also have a special coating, which may be sensitive to mechanical stress, or to fat and liquids. For this reason we recommend you do not touch them.

If you are not sure how sensitive your device is to cleaning, please contact the manufacturer or your sales distributor.

Premoistened cleaning wipes

Use pre-moistened cleaning wipes as described in each individual cleaning procedure. Cleaning wipes may be used in every instance where a moistened soft tissue or cotton swab is applied.

Polymer film

Polymer film is available from laboratory suppliers or specialist mail order companies.

Using polymer film is a gentle method of cleaning extremely sensitive devices, such as reference reflectors and mirrors.

Infrared Sensor Card

Infrared sensor cards are available from laboratory suppliers or specialist mail order companies.

With this card you are able to control the shape of laser light emitted. The invisible laser beam is projected onto the sensor card, then becomes visible to the normal eye as a round spot.

Take care never to look into the end of a fiber or any other optical component, when they are in use. This is because the laser can seriously damage your eyes.

Preserving Connectors

Listed below are some hints on how best to keep your connectors in the best possible condition.

Making Connections Before you make any connection you must ensure that all cables and connectors are clean. If they are dirty, use the appropriate cleaning procedure.

When inserting the ferrule of a patchcord into a connector or an adapter, make sure that the fiber end does not touch the outside of the mating connector or adapter. Otherwise you will rub the fiber end against an unsuitable surface, producing scratches and dirt deposits on the surface of your fiber.

Dust Caps and Shutter Caps Be careful when replacing dust caps after use. Do not press the bottom of the cap onto the fiber as any dust in the cap can scratch or dirty your fiber surface.

When you have finished cleaning, put the dust cap back on, or close the shutter cap if the equipment is not going to be used immediately.

Always keep the caps on the equipment when it is not in use.

All of Keysight Technologies' lightwave instruments and accessories are shipped with either laser shutter caps or dust caps. If you need additional or replacement dust caps, contact your nearest Keysight Technologies Sales/Service Office.

Immersion Oil and Other Index Matching Compounds Wherever possible, do not use immersion oil or other index matching compounds with your device. They are liable to impair and dirty the surface of the device. In addition, the characteristics of your device can be changed and your measurement results affected.

Cleaning Instrument Housings

Use a dry and very soft cotton tissue to clean the instrument housing and the keypad. Do not open the instruments as there is a danger of electric shock, or electrostatic discharge. Opening the instrument can cause damage to sensitive components, and in addition your warranty will be voided.

Which Cleaning Procedure should I use ?

Light dirt If you just want to clean away light dirt, observe the following procedure for all devices:

- Use compressed air to blow away large particles.

- Clean the device with a dry cotton swab.
- Use compressed air to blow away any remaining filament left by the swab.

Heavy dirt If the above procedure is not enough to clean your instrument, follow one of the procedures below. Please consult “*Cleaning Instructions for this Instrument*” on page 87 for the procedure relevant for this instrument.

If you are unsure of how sensitive your device is to cleaning, please contact the manufacturer or your sales distributor

How to clean connectors

Cleaning connectors is difficult as the core diameter of a single-mode fiber is only about 9 μm . This generally means you cannot see streaks or scratches on the surface. To be certain of the condition of the surface of your connector and to check it after cleaning, you need a microscope.

In the case of scratches, or of dust that has been burnt onto the surface of the connector, you may have no option but to polish the connector. This depends on the degree of dirtiness, or the depth of the scratches. This is a difficult procedure and should only be performed by a skilled person, and as a last resort as it wears out your connector.

WARNING

Never look into the end of an optical cable that is connected to an active source.

To assess the projection of the emitted light beam you can use an infrared sensor card. Hold the card approximately 5 cm from the output of the connector. The invisible emitted light is projected onto the card and becomes visible as a small circular spot.

Preferred Procedure Use the following procedure on most occasions.

- 1 Clean the connector by rubbing a new, dry cotton swab over the surface using a small circular movement.
- 2 Blow away any remaining lint with compressed air.

Procedure for Stubborn Dirt Use this procedure when there is greasy dirt on the connector:

- 1 Moisten a new cotton swab with isopropyl alcohol.

- 2 Clean the connector by rubbing the cotton swab over the surface using a small circular movement.
- 3 Take a new, dry soft tissue and remove the alcohol, dissolved sediment and dust, by rubbing gently over the surface using a small circular movement.
- 4 Blow away any remaining lint with compressed air.

An Alternative Procedure A better, more gentle, but more expensive cleaning procedure is to use an ultrasonic bath with isopropyl alcohol.

- 1 Hold the tip of the connector in the bath for at least three minutes.
- 2 Take a new, dry soft tissue and remove the alcohol, dissolved sediment and dust, by rubbing gently over the surface using a small circular movement.
- 3 Blow away any remaining lint with compressed air.

How to clean connector adapters

CAUTION

Some adapters have an anti-reflection coating on the back to reduce back reflection. This coating is extremely sensitive to solvents and mechanical abrasion. Extra care is needed when cleaning these adapters.

Preferred Procedure Use the following procedure on most occasions.

- 1 Clean the adapter by rubbing a new, dry cotton swab over the surface using a small circular movement.
- 2 Blow away any remaining lint with compressed air.

Procedure for Stubborn Dirt Use this procedure when there is greasy dirt on the adapter:

- 1 Moisten a new cotton swab with isopropyl alcohol.
- 2 Clean the adapter by rubbing the cotton swab over the surface using a small circular movement.
- 3 Take a new, dry soft tissue and remove the alcohol, dissolved sediment and dust, by rubbing gently over the surface using a small circular movement.

- 4 Blow away any remaining lint with compressed air.

How to clean connector interfaces

CAUTION

Be careful when using pipe cleaners, as the core and the bristles of the pipe cleaner are hard and can damage the interface.

Do not use pipe cleaners on optical head adapters, as the hard core of normal pipe cleaners can damage the bottom of an adapter.

Preferred Procedure Use the following procedure on most occasions.

- 1 Clean the interface by pushing and pulling a new, dry pipe cleaner into the opening. Rotate the pipe cleaner slowly as you do this.
- 2 Then clean the interface by rubbing a new, dry cotton swab over the surface using a small circular movement.
- 3 Blow away any remaining lint with compressed air.

Procedure for Stubborn Dirt Use this procedure when there is greasy dirt on the interface:

- 1 Moisten a new pipe cleaner with isopropyl alcohol.
- 2 Clean the interface by pushing and pulling the pipe cleaner into the opening. Rotate the pipe cleaner slowly as you do this.
- 3 Moisten a new cotton swab with isopropyl alcohol.
- 4 Clean the interface by rubbing the cotton swab over the surface using a small circular movement.
- 5 Using a new, dry pipe cleaner, and a new, dry cotton swab remove the alcohol, any dissolved sediment and dust.
- 6 Blow away any remaining lint with compressed air.

How to clean bare fiber adapters

Bare fiber adapters are difficult to clean. Protect from dust unless they are in use.

CAUTION

Never use any kind of solvent when cleaning a bare fiber adapter as solvents can:

- Damage the foam inside some adapters.

Deposit dissolved dirt in the groove, which can then dirty the surface of an inserted fiber.

Preferred Procedure Use the following procedure on most occasions.

- 1 Blow away any dust or dirt with compressed air.

Procedure for Stubborn Dirt Use this procedure when there is greasy dirt on the adapter:

- 1 Clean the adapter by pushing and pulling a new, dry pipe cleaner into the opening. Rotate the pipe cleaner slowly as you do this.

CAUTION

Be careful when using pipe cleaners, as the core and the bristles of the pipe cleaner are hard and can damage the adapter.

- 2 Clean the adapter by rubbing a new, dry cotton swab over the surface using a small circular movement.
- 3 Blow away any remaining lint with compressed air.

How to clean lenses

Some lenses have special coatings that are sensitive to solvents, grease, liquid and mechanical abrasion. Take extra care when cleaning lenses with these coatings.

Lens assemblies consisting of several lenses are not normally sealed. Therefore, use as little alcohol as possible, as it can get between the lenses and in doing so can change the properties of projection.

Preferred Procedure Use the following procedure on most occasions.

- 1 Clean the lens by rubbing a new, dry cotton swab over the surface using a small circular movement.
- 2 Blow away any remaining lint with compressed air.

Procedure for Stubborn Dirt Use this procedure when there is greasy dirt on the lens:

- 1 Moisten a new cotton swab with isopropyl alcohol.
- 2 Clean the lens by rubbing the cotton swab over the surface using a small circular movement.
- 3 Using a new, dry cotton swab remove the alcohol, any dissolved sediment and dust.
- 4 Blow away any remaining lint with compressed air.

How to clean instruments with a fixed connector interface

You should only clean instruments with a fixed connector interface when it is absolutely necessary. This is because it is difficult to remove any used alcohol or filaments from the input of the optical block.

It is important, therefore, to keep dust caps on the equipment at all times, except when your optical device is in use.

If you do discover filaments or particles, the only way to clean a fixed connector interface and the input of the optical block is to use compressed air.

If there are fluids or fat in the connector, please refer the instrument to the skilled personnel of Keysight's service team.

CAUTION

Only use clean, dry compressed air. Make sure that the air is free of dust, water, and oil. If the air that you use is not clean and dry, this can lead to filmy deposits or scratches on the surface of your connector interface. This will degrade the performance of your transmission system.

Never try to open the instrument and clean the optical block by yourself, because it is easy to scratch optical components, and cause them to become misaligned.

How to clean instruments with an optical glass plate

Some instruments, for example, the optical heads from Keysight Technologies have an optical glass plate to protect the sensor. Clean this glass plate in the same way as optical lenses (see “*How to clean lenses*” on page 99).

How to clean instruments with a physical contact interface

Remove any connector interfaces from the optical output of the instrument before you begin the cleaning procedure.

Cleaning interfaces is difficult as the core diameter of a single-mode fiber is only about 9 μm . This generally means you cannot see streaks or scratches on the surface. To be certain of the degree of pollution on the surface of your interface and to check whether it has been removed after cleaning, you need a microscope.

WARNING

Never look into an optical output, because this can seriously damage your eyesight.

To assess the projection of the emitted light beam you can use an infrared sensor card. Hold the card approximately 5 cm from the interface. The invisible emitted light is projected onto the card and becomes visible as a small circular spot.

Never look into an optical output, because this can seriously damage your eyesight.

To assess the projection of the emitted light beam you can use an infrared sensor card. Hold the card approximately 5 cm from the interface. The invisible emitted light is projected onto the card and becomes visible as a small circular spot.

Preferred Procedure Use the following procedure on most occasions.

- 1 Clean the interface by rubbing a new, dry cotton swab over the surface using a small circular movement.
- 2 Blow away any remaining lint with compressed air.

Procedure for Stubborn Dirt Use this procedure when there is greasy dirt on the interface:

- 1 Moisten a new cotton swab with isopropyl alcohol.
- 2 Clean the interface by rubbing the cotton swab over the surface using a small circular movement.
- 3 Take a new, dry soft tissue and remove the alcohol, dissolved sediment and dust, by rubbing gently over the surface using a small circular movement.
- 4 Blow away any remaining lint with compressed air.

How to clean instruments with a recessed lens interface

WARNING

For instruments with a deeply recessed lens interface (for example the Keysight 81633A and 81634A Power Sensors) do NOT follow this procedure. Alcohol and compressed air could damage your lens even further.

Keep your dust and shutter caps on when your instrument is not in use. This should prevent it from getting too dirty. If you must clean such instruments, please refer the instrument to the skilled personnel of Keysight's service team.

Preferred Procedure Use the following procedure on most occasions.

- 1 Blow away any dust or dirt with compressed air.
If this is not sufficient, then
- 2 Clean the interface by rubbing a new, dry cotton swab over the surface using a small circular movement.
- 3 Blow away any remaining lint with compressed air.

Procedure for Stubborn Dirt Use this procedure when there is greasy dirt on the interface, and using the preferred procedure is not sufficient. Using isopropyl alcohol should be your last choice for recessed lens interfaces because of the difficulty of cleaning out any dirt that is washed to the edge of the interface:

- 1 Moisten a new cotton swab with isopropyl alcohol.
- 2 Clean the interface by rubbing the cotton swab over the surface using a small circular movement.
- 3 Take a new, dry soft tissue and remove the alcohol, dissolved sediment and dust, by rubbing gently over the surface using a small circular movement.
- 4 Blow away any remaining lint with compressed air.

How to clean optical devices which are sensitive to mechanical stress and pressure

Some optical devices, such as the Keysight 81000BR Reference Reflector, which has a gold plated surface, are very sensitive to mechanical stress or pressure. Do not use cotton swabs, soft tissues or other mechanical cleaning tools, as these can scratch or destroy the surface.

Preferred Procedure Use the following procedure on most occasions.

- 1 Blow away any dust or dirt with compressed air.

Procedure for Stubborn Dirt To clean devices that are extremely sensitive to mechanical stress or pressure you can also use an optical clean polymer film. This procedure is time-consuming, but you avoid scratching or destroying the surface.

- 1 Put the film on the surface and wait at least 30 minutes to make sure that the film has had enough time to dry.

- 2 Remove the film and any dirt with special adhesive tapes.

Alternative Procedure For these types of optical devices you can often use an ultrasonic bath with isopropyl alcohol. Only use the ultrasonic bath if you are sure that it won't cause any damage any part of the device.

- 1 Put the device into the bath for at least three minutes.
- 2 Blow away any remaining liquid with compressed air.

If there are any streaks or drying stains on the surface, repeat the cleaning procedure.

How to clean metal filters or attenuator gratings

This kind of device is extremely fragile. A misalignment of the grating leads to inaccurate measurements. Never touch the surface of the metal filter or attenuator grating. Be very careful when using or cleaning these devices. Do not use cotton swabs or soft tissues, as there is the danger that you cannot remove the lint and that the device will be destroyed by becoming mechanically distorted.

Preferred Procedure Use the following procedure on most occasions.

- 1 Use compressed air at a distance and with low pressure to remove any dust or lint.

Procedure for Stubborn Dirt Do not use an ultrasonic bath as this can damage your device.

Use this procedure when there is greasy dirt on the device:

- 1 Put the optical device into a bath of isopropyl alcohol, and wait at least 10 minutes.
- 2 Remove the fluid using compressed air at some distance and with low pressure. If there are any streaks or drying stains on the surface, repeat the whole cleaning procedure.

Additional Cleaning Information

The following cleaning procedures may be used with other optical equipment:

- [How to clean bare fiber ends](#)
- [How to clean large area lenses and mirrors](#)

How to clean bare fiber ends

Bare fiber ends are often used for splices or, together with other optical components, to create a parallel beam. The end of a fiber can often be scratched. You make a new cleave. To do this:

- 1 Strip off the cladding.
- 2 Take a new soft tissue and moisten it with isopropyl alcohol.
- 3 Carefully clean the bare fiber with this tissue.
- 4 Make your cleave and immediately insert the fiber into your bare fiber adapter in order to protect the surface from dirt.

How to clean large area lenses and mirrors

Some mirrors, as those from a monochromator, are very soft and sensitive. Therefore, never touch them and do not use cleaning tools such as compressed air or polymer film.

Some lenses have special coatings that are sensitive to solvents, grease, liquid and mechanical abrasion. Take extra care when cleaning lenses with these coatings.

Lens assemblies consisting of several lenses are not normally sealed. Therefore, use as little liquid as possible, as it can get between the lenses and in doing so can change the properties of projection.

Preferred Procedure Use the following procedure on most occasions.

- 1 Blow away any dust or dirt with compressed air.

Procedure for Stubborn Dirt Use this procedure when there is greasy dirt on the lens:

CAUTION

Only use water if you are sure that there is no other way of cleaning your optical device without causing corrosion or damage.

Only use water if you are sure that there is no other way of cleaning your optical device without causing corrosion or damage. Do not use hot water, as this may cause mechanical stress, which can damage your optical device.

Ensure that your liquid soap has no abrasive properties or perfume in it. You should also avoid normal washing up liquid, as it can cover your device in an iridescent film after it has been air dried.

Some lenses and mirrors also have a special coating, which may be sensitive to mechanical stress, or to fat and liquids. For this reason we recommend you do not touch them.

If you are not sure how sensitive your device is to cleaning, please contact the manufacturer or your sales distributor.

- 1 Moisten the lens or the mirror with water.
- 2 Put a little liquid soap on the surface and gently spread the liquid over the whole area.
- 3 Wash off the emulsion with water, being careful to remove it all, as any remaining streaks can impair measurement accuracy.
- 4 Take a new, dry soft tissue and remove the water, by rubbing gently over the surface using a small circular movement.
- 5 Blow away remaining lint with compressed air.

Alternative Procedure A To clean lenses that are extremely sensitive to mechanical stress or pressure you can also use an optical clean polymer film. This procedure is time-consuming, but you avoid scratching or destroying the surface.

- 1 Put the film on the surface and wait at least 30 minutes to make sure that the film has had enough time to dry.
- 2 Remove the film and any dirt with special adhesive tapes.

Alternative Procedure B If your lens is sensitive to water then:

- 1 Moisten the lens or the mirror with isopropyl alcohol.
- 2 Take a new, dry soft tissue and remove the alcohol, dissolved sediment and dust, by rubbing gently over the surface using a small circular movement.
- 3 Blow away remaining lint with compressed air.

Other Cleaning Hints

Selecting the correct cleaning method is an important element in maintaining your equipment and saving you time and money. This Appendix highlights the main cleaning methods, but cannot address every individual circumstance.

This section contains some additional hints which we hope will help you further. For further information, please contact your local Keysight Technologies representative.

Making the connection Before you make any connection you must ensure that all lightwave cables and connectors are clean. If not, then use the appropriate cleaning methods.

When you insert the ferrule of a patchcord into a connector or an adapter, ensure that the fiber end does not touch the outside of the mating connector or adapter. Otherwise, the fiber end will rub up against something which could scratch it and leave deposits.

Lens cleaning papers Some special lens cleaning papers are not suitable for cleaning optical devices like connectors, interfaces, lenses, mirrors and so on. To be absolutely certain that a cleaning paper is applicable, please ask the salesperson or the manufacturer.

Immersion oil and other index matching compounds Do not use immersion oil or other index matching compounds with optical sensors equipped with recessed lenses. They are liable to dirty the detector and impair its performance. They may also alter the property of depiction of your optical device, thus rendering your measurements inaccurate.

Cleaning the housing and the mainframe When cleaning either the mainframe or the housing of your instrument, only use a dry and very soft cotton tissue on the surfaces and the numeric pad.

Never open the instruments as they can be damaged. Opening the instruments puts you in danger of receiving an electrical shock from your device, and renders your warranty void.

Index

C

Conventions 10

D

Definition of Terms 50

Dynamic Range 51

External Input Damage Power 51

External Input Power Range 51

Relative Uncertainty 51

Return Loss 50

Total Uncertainty 53

Wavelength Range 51

I

Initial Safety Information 7

Insertion Loss 20

O

Optical Output 18

P

Performance Tests 59

81610A 75, 79, 83

Dynamic Range 62

Relative Uncertainty 62

Required Equipment 60

Test Failure 61

R

Recommended Connector Interfaces 48

Return Loss 15

Getting Started 16

Light Source 21

This information is subject to change without notice.
© Keysight Technologies 2000, 2015
Edition 6, February 2015



81610-90A15

www.keysight.com