

Errata

Title & Document Type: 6206B DC Power Supply Operating and Service Manual

Manual Part Number: 06206-90002

Revision Date: February 1970

About this Manual

We've added this manual to the Agilent website in an effort to help you support your product. This manual provides the best information we could find. It may be incomplete or contain dated information, and the scan quality may not be ideal. If we find a better copy in the future, we will add it to the Agilent website.

HP References in this Manual

This manual may contain references to HP or Hewlett-Packard. Please note that Hewlett-Packard's former test and measurement, life sciences, and chemical analysis businesses are now part of Agilent Technologies. The HP XXXX referred to in this document is now the Agilent XXXX. For example, model number HP8648A is now model number Agilent 8648A. We have made no changes to this manual copy.

Support for Your Product

Agilent no longer sells or supports this product. You will find any other available product information on the Agilent Test & Measurement website:

www.agilent.com

Search for the model number of this product, and the resulting product page will guide you to any available information. Our service centers may be able to perform calibration if no repair parts are needed, but no other support from Agilent is available.



Agilent Technologies



**DC POWER SUPPLY
LAB SERIES
MODEL 6206B**

OPERATING AND SERVICE MANUAL

FOR SERIALS 8M2352 - UP*

***For Serials Above 8M2351
Check for inclusion of change page.**

***For Serials Below 8M2352
Refer to Appendix B**

100 Locust Avenue, Berkeley Heights, New Jersey 07922

TABLE OF CONTENTS

Section	Page No.	Section	Page No.
I GENERAL INFORMATION	1-1	IV PRINCIPLES OF OPERATION	4-1
1-1 Description	1-1	4-1 Overall Description	4-1
1-6 Specifications	1-1	4-8 Detailed Circuit Analysis	4-2
1-8 Options	1-1	4-9 Feedback Loop	4-2
1-10 Accessories	1-2	4-13 Series Regulator	4-2
1-12 Instrument and Service Manual Identification	1-2	4-15 Constant Voltage Comparator	4-2
1-15 Ordering Additional Manuals	1-2	4-19 Error Amplifier and Driver	4-2
II INSTALLATION	2-1	4-22 Current Limit Circuit	4-3
2-1 Initial Inspection	2-1	4-26 Reference Circuit	4-3
2-3 Mechanical Check	2-1	4-29 Meter Circuit	4-3
2-5 Electrical Check	2-1	V MAINTENANCE	5-1
2-7 Installation Data	2-1	5-1 Introduction	5-1
2-9 Location	2-1	5-3 General Measurement Techniques	5-1
2-11 Outline Diagram	2-1	5-8 Test Equipment Required	5-2
2-13 Rack Mounting	2-1	5-10 Performance Test	5-3
2-17 Input Power Requirements	2-3	5-12 Constant Voltage Tests	5-3
2-19 Connections for 230 Volt Operation	2-3	5-38 Output Impedance	5-7
2-21 Power Cable	2-3	5-48 Troubleshooting	5-9
2-24 Repackaging for Shipment	2-3	5-53 Overall Troubleshooting Procedure	5-9
III OPERATING INSTRUCTIONS	3-1	5-58 Repair and Replacement	5-12
3-1 Turn-on Checkout Procedure	3-1	5-50 Adjustment and Calibration	5-13
3-3 Operating Modes	3-1	5-62 Meter Zero	5-13
3-5 Normal Operating Mode	3-1	5-64 Ammeter Tracking	5-13
3-7 Constant Voltage	3-1	5-66 Constant Voltage Programming Current	5-13
3-9 Changing Current Limit	3-2	5-69 Reference Circuit Adjustments	5-15
3-11 Connecting Load	3-2	5-71 Constant Voltage Transient Recovery Time	5-15
3-14 Operation Beyond Normal Rated Output	3-2	5-73 Current Limit Adjustment	5-15
3-16 Optional Operating Modes	3-2	VI REPLACEABLE PARTS	6-1
3-17 Remote Programming, Constant Voltage	3-2	6-1 Introduction	6-1
3-25 Remote Sensing	3-3	6-4 Ordering Information	6-1
3-30 Series Operation	3-4	APPENDIX A	A-1
3-35 Auto-Tracking Operation	3-5	APPENDIX B	B-1
3-38 Special Operating Considerations	3-6	VII CIRCUIT DIAGRAMS	7-1
3-39 Pulse Loading	3-6		
3-41 Output Capacitance	3-6		
3-43 Reverse Voltage Loading	3-6		
3-45 Reverse Current Loading	3-6		

LIST OF ILLUSTRATIONS

Figure		Page No.	Figure		Page No.
2-1	Outline Diagram,	2-1	4-2	Multiple Range Meter Circuit, Simplified Schematic	4-4
2-2	Rack Mounting, Two Units	2-2	5-1	Front Panel Terminal Connections	5-1
2-3	Rack Mounting, One Unit	2-2	5-2	Output Current Measurement Technique	5-1
2-4	Primary Connections	2-3	5-3	Differential Voltmeter Substitute, Test Setup	5-2
3-1	Front Panel Controls and Indicators	3-1	5-4	Output Current, Test Setup	5-4
3-2	Normal Strapping Pattern	3-1	5-5	Load Regulation, Test Setup	5-4
3-3	Current Limit Alteration	3-2	5-6	CV Ripple and Noise, Test Setup	5-5
3-4	Remote Resistance Programming	3-3	5-7	CV Noise Spike, Test Setup	5-6
3-5	Remote Voltage Programming	3-3	5-8	Transient Recovery Time, Test Setup	5-7
3-6	Remote Sensing	3-3	5-9	Transient Recovery Time, Waveforms	5-7
3-7	Normal Series Connections	3-4	5-10	Output Impedance, Test Setup	5-8
3-8	Auto-Series, Two and Three Units	3-4	5-11	Servicing Printed Wiring Boards	5-14
3-9	Auto-Parallel, Two and Three Units	3-5			
3-10	Auto-Tracking, Two and Three Units	3-5			
4-1	Overall Block Diagram	4-1			

LIST OF TABLES

Table	Page No.
1-1 Specifications	1-3
5-1 Test Equipment Required	5-2
5-2 Reference Circuit Troubleshooting	5-9
5-3 Overall Troubleshooting	5-9
5-4 High Output Voltage Troubleshooting	5-11
5-5 Low Output Voltage Troubleshooting	5-11
5-6 Selected Semiconductor Characteristics	5-12
5-7 Checks and Adjustments After Replacement of Semiconductor Devices	5-12
6-1 Reference Designators	6-1
6-2 Description Abbreviations	6-1
6-3 Code List of Manufacturers	6-2
6-4 Replaceable Parts	6-5

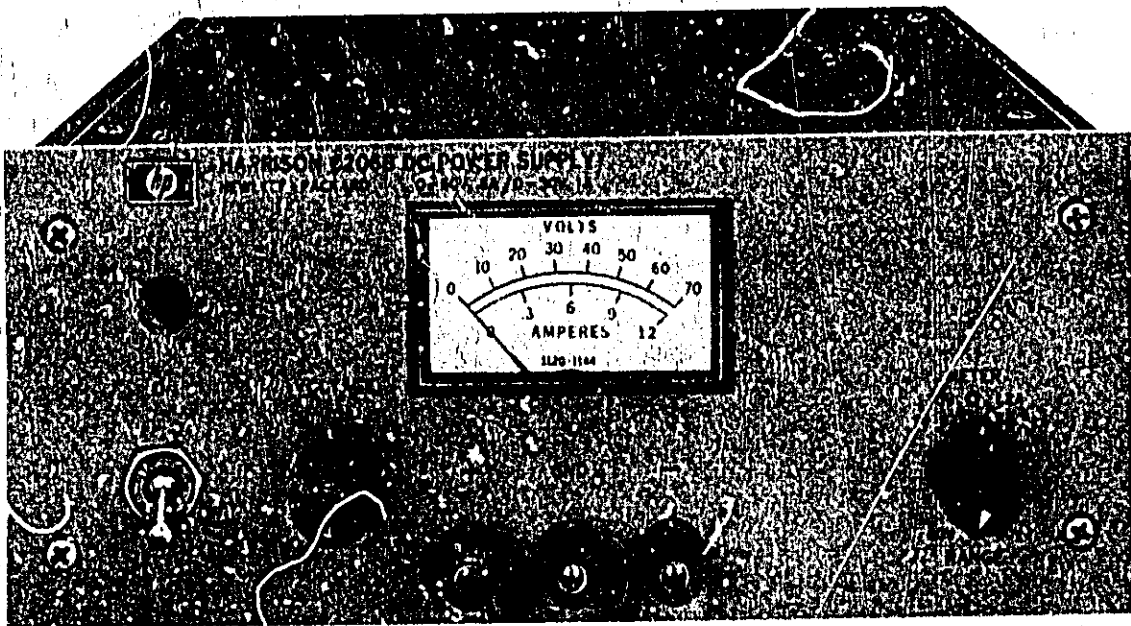

Figure 1-1. DC Power Supply, Model 6206B

SECTION I GENERAL INFORMATION

1-1 DESCRIPTION

1-2 This power supply, Figure 1-1, is completely transistorized and suitable for either bench or relay rack operation. It is a dual range, compact, regulated, Constant Voltage/Current Limiting supply. The unit can be operated in one of two modes with selection of the operating mode provided by the front panel RANGE switch. The output voltage can be continuously adjusted throughout either output range. The power supply is fully protected from overloads by a fixed current limit which is set by means of an internal adjustment.

1-3 The power supply has both front and rear terminals. Either the positive or negative output terminal may be grounded or the power supply can be operated floating at up to a maximum of 300 Volts off ground.

1-4 A single meter is used to measure either output voltage or output current in one of two ranges for each operating mode. The voltage or current range is selected by the METER switch on the front panel.

1-5 The programming terminals located at the rear of the unit allow ease in adapting to the many operational capabilities of the power supply. A brief description of these capabilities is given below:

a. Remote Programming. The power supply may be programmed from a remote location by means of an external voltage source or resistance.

b. Remote Sensing. The degradation in regulation which would occur at the load because of the voltage drop which takes place in the load leads can be reduced by using the power supply in the remote sensing mode of operation.

c. Series and Auto-Series Operation. Power supplies may be used in series when a higher output voltage is required in the voltage mode of operation or when greater voltage compliance is required in the constant current mode of operation. Auto-Series operation permits one knob control of the total output voltage from a "master" supply.

d. Parallel and Auto-Parallel Operation. The power supply may be operated in parallel with a similar unit when greater output current capability is required. Auto-Parallel operation permits one knob control of the total output current from a "master" supply.

e. Auto-Tracking. The power supply may be used as a "master" supply, having control over one (or more) "slave" supplies that furnish various voltages for a system.

1-6 SPECIFICATIONS

1-7 Detailed specifications for the power supply are given in Table 1-1.

1-8 OPTIONS

1-9 Options are factory modifications of a standard instrument that are requested by the customer. The following options are available for the instrument covered by this manual. Where necessary, detailed coverage of the options is included throughout the manual.

<u>Option No.</u>	<u>Description</u>
07	Voltage 10-Turn Pot: A single control that replaces both coarse and fine voltage controls and improves output settability.
11	Overvoltage Protection "Crowbar": A completely separate circuit for protecting delicate loads against power supply failure or operator error. This independent device monitors the output voltage and within 10 μ sec imposes a virtual short-circuit (crowbar) across the power supply output if the preset trip voltage is exceeded. When Option 11 is requested by the customer the device is connected at the factory. Trip Voltage Range: 2.5 to 44 Volts, screwdriver adjustable. Detailed coverage of Option 11 is included in Appendix A at the rear of manuals that support power supplies containing Option 11.
13	Three Digit Graduated Decadal Voltage Control: Control that replaces coarse and fine voltage controls permitting accurate resettability.
28	230Vac Input: Supply as normally

Option No.

Description

(28) shipped is wired for 115Vac input. Option 28 consists of reconnecting the input transformer for 230Vac operation.

1-10 ACCESSORIES

1-11 The accessories listed in the following chart may be ordered with the power supply or separately from your local Hewlett-Packard field sales office (refer to list at rear of manual for addresses).

HP Part No.

Description

- C05 8" Black Handle that can be attached to side of supply.
- 14513A Rack Kit for mounting one 3 1/2" high supply. (Refer to Section II for details.)
- 14523A Rack Kit for mounting two 3 1/2" high supplies. (Refer to Section II for details.)

1-12 INSTRUMENT AND SERVICE MANUAL IDENTIFICATION

1-13 Hewlett-Packard power supplies are identified

by a three-part serial number tag. The first part is the power supply model number. The second part is the serial number prefix, which consists of a number-letter combination that denotes the date of a significant design change. The number designates the year, and the letter A through L designates the month, January through December respectively, with "I" omitted. The third part is the power supply serial number.

1-14 If the serial number prefix on your power supply does not agree with the prefix on the title page of this manual, change sheets are included to update the manual. Where applicable, back-dating information is given in an appendix at the rear of the manual.

1-15 ORDERING ADDITIONAL MANUALS

1-16 One manual is shipped with each power supply. Additional manuals may be purchased from your local Hewlett-Packard field office (see list at rear of this manual for addresses). Specify the model number, serial number prefix, and HP part number provided on the title page.

Table 1-1. Specifications

<p>INPUT: 115Vac \pm 10%, single phase, 48-440Hz.</p> <p>OUTPUT: 0-30 volts @ 1 ampere or 0-60 volts @ 0.5 ampere.</p> <p>LOAD REGULATION: Less than 0.01% plus 4mV for a full load to no load change in output current.</p> <p>LINE REGULATION: Less than 0.01% plus 4mV for any line voltage change within the input rating.</p> <p>RIPPLE AND NOISE: Less than 200μVrms / 15mV peak-to-peak.</p> <p>TEMPERATURE RANGES: Operating: 0 to 55°C. Storage: -40 to +75°C.</p> <p>TEMPERATURE COEFFICIENT: Less than 0.02% plus 1mV per degree Centigrade.</p> <p>STABILITY: Less than 0.10% plus 5mV total drift for eight hours after an initial warm-up time of 30 minutes at constant ambient, constant line voltage, and constant load.</p> <p>INTERNAL IMPEDANCE AS A CONSTANT VOLTAGE SOURCE: Less than 0.02 ohms from dc to 1kHz, Less than 0.5 ohms from 1kHz to 100kHz, Less than 3.0 ohms from 100kHz to 1MHz.</p> <p>TRANSIENT RECOVERY TIME: Less than 50μsec for output recovery to within 10mV following a full load current change in the output.</p> <p>OVERLOAD PROTECTION: A fixed current limiting circuit protects the power supply for all overloads including a direct short placed across the terminals in constant voltage operation. The current limit can be changed by utilizing terminals available at the rear of the unit.</p>	<p>METER: The front panel meter can be used as either a 0-70V or 0-7V voltmeter or as a 0-1.2A or 0-0.12 ampere ammeter.</p> <p>OUTPUT CONTROLS: Range switch selects desired operating mode. Coarse and fine voltage controls set desired output voltage.</p> <p>OUTPUT TERMINALS: Three "five-way" output posts are provided on the front panel and an output terminal strip is located on the rear of the chassis. All power supply output terminals are isolated from the chassis and either the positive or negative terminal may be connected to the chassis through a separate ground terminal located on the output terminal strip.</p> <p>ERROR SENSING: Error sensing is normally accomplished at the front terminals if the load is attached to the front or at the rear terminals if the load is attached to the rear terminals. Also, provision is included on the rear terminal strip for remote sensing.</p> <p>REMOTE PROGRAMMING: Remote programming of the supply output at approximately 300 ohms per volt in constant voltage operation is made available at the rear terminals.</p> <p>COOLING: Convection cooling is employed. The supply has no moving parts.</p> <p>SIZE: 3$\frac{1}{2}$" H x 12-5/8" D x 8$\frac{1}{2}$" W. Two of the units can be mounted side by side in a standard 19" relay rack.</p> <p>WEIGHT: 10 lbs. net, 13 lbs. shipping.</p> <p>FINISH: Light gray panel with dark gray case.</p> <p>POWER CORD: A three-wire, five-foot power cord is provided with each unit.</p>
--	--

SECTION II INSTALLATION

2-1 INITIAL INSPECTION

2-2 Before shipment, this instrument was inspected and found to be free of mechanical and electrical defects. As soon as the instrument is unpacked, inspect for any damage that may have occurred in transit. Save all packing materials until the inspection is completed. If damage is found, a claim should be filed with the carrier. Hewlett-Packard Sales and Service office should be notified.

2-3 MECHANICAL CHECK

2-4 This check should confirm that there are no broken knobs or connectors, that the cabinet and panel surfaces are free of dents and scratches, and that the meter is not scratched or cracked.

2-5 ELECTRICAL CHECK

2-6 The instrument should be checked against its electrical specifications. Section V includes an "in-cabinet" performance check to verify proper instrument operation.

2-7 INSTALLATION DATA

2-8 The instrument is shipped ready for bench operation. It is necessary only to connect the instrument to a source of power and it is ready for operation.

2-9 LOCATION

2-10 This instrument is air cooled. Sufficient space should be allotted so that a free flow of cooling air can reach the sides and rear of the instrument when it is in operation. It should be used in an area where the ambient temperature does not exceed 50°C.

2-11 OUTLINE DIAGRAM

2-12 Figure 2-1 is an outline diagram showing the dimensions of the instrument.

2-13 RACK MOUNTING

2-14 This instrument may be rack mounted in a standard 19 inch rack panel either alongside a similar unit or by itself. Figures 2-2 and 2-3 show

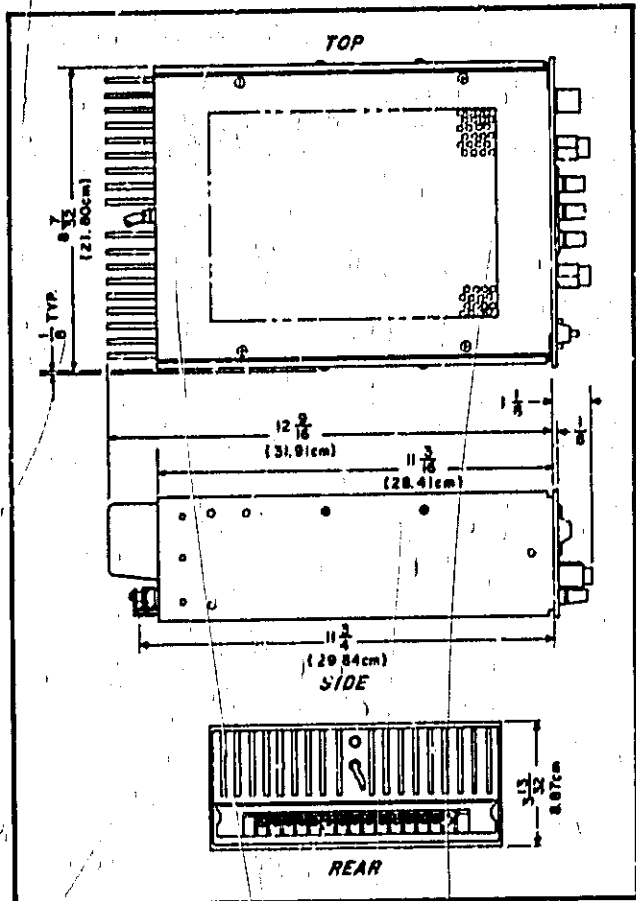

Figure 2-1. Outline Diagram

how both types of installations are accomplished.

2-15 To mount two units side-by-side, proceed as follows:

- a. Remove the four screws from the front panels of both units.
- b. Slide rack mounting ears between the front panel and case of each unit.
- c. Slide combining strip between the front panels and cases of the two units.
- d. After fastening rear portions of units together using the bolt, nut, and spacer, replace panel screws.

2-16 To mount a single unit in the rack panel, proceed as follows:

- a. Bolt rack mounting ears, combining straps, and angle brackets to each side of center

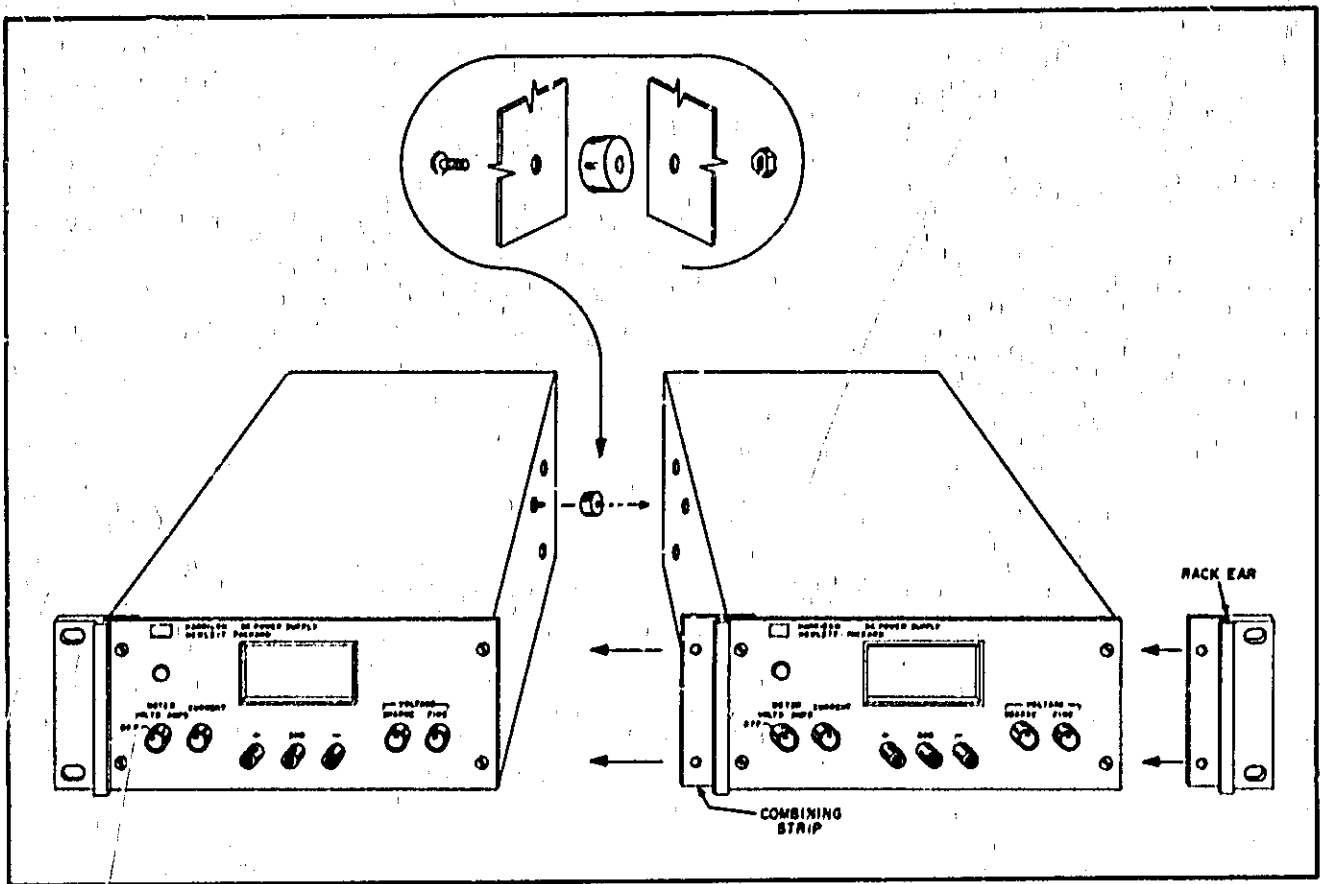

Figure 2-2. Rack Mounting, Two Units

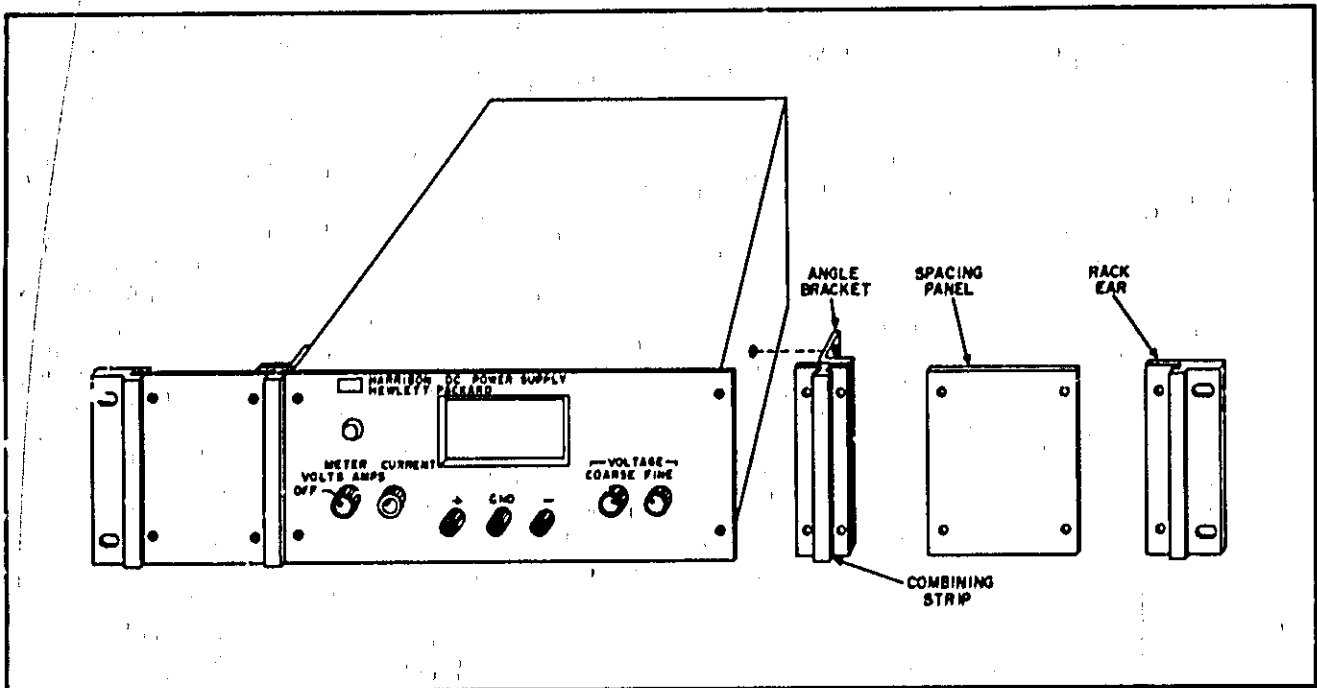

Figure 2-3. Rack Mounting, One Unit

spacing panels. Angle brackets are placed behind combining straps as shown in Figure 2-3.

b. Remove four screws from front panel of unit.

c. Slide combining strips between front panel and case of unit.

d. Bolt angle brackets to front sides of case and replace front panel screws.

2-17 INPUT POWER REQUIREMENTS

2-18 This power supply may be operated from either a nominal 115 Volt or 230 Volt 48-440 Hertz power source. The unit, as shipped from the factory, is wired for 115 Volt operation. The input power required when operated from a 115 Volt 60 Hertz power source at full load is 31 Watts and 0.35 Amperes.

2-19 CONNECTIONS FOR 230 VOLT OPERATION

2-20 Normally, the two primary windings of the input transformer are connected in parallel for operation from 115 Volt source. To convert the power supply to operation from a 230 Volt source, the power transformer windings are connected in series as follows:

a. Unplug the line cord and remove the unit from case.

b. Break the copper between 54 and 55 and also between 50 and 51 on the printed circuit board. These are shown in Figure 2-4, and are labeled on copper side of printed circuit board.

c. Add strap between 50 and 55.

d. Replace existing fuse with 1 Ampere, 230 Volt fuse. Return unit to case and operate normally.

2-21 POWER CABLE

2-22 To protect operating personnel, the National Electrical Manufacturers Association (NEMA) recommends that the instrument panel and cabinet be grounded. This instrument is equipped with a three conductor power cable. The third conductor is the ground conductor and when the cable is plugged into an appropriate receptacle, the instrument is grounded. The offset pin on the power cable three-prong connector is the ground connection.

2-23 To preserve the protection feature when operating the instrument from a two-contact outlet, use a three-prong to two-prong adapter and connect the green lead on the adapter to ground.

2-24 REPACKAGING FOR SHIPMENT

2-25 To insure safe shipment of the instrument, it is recommended that the package designed for the

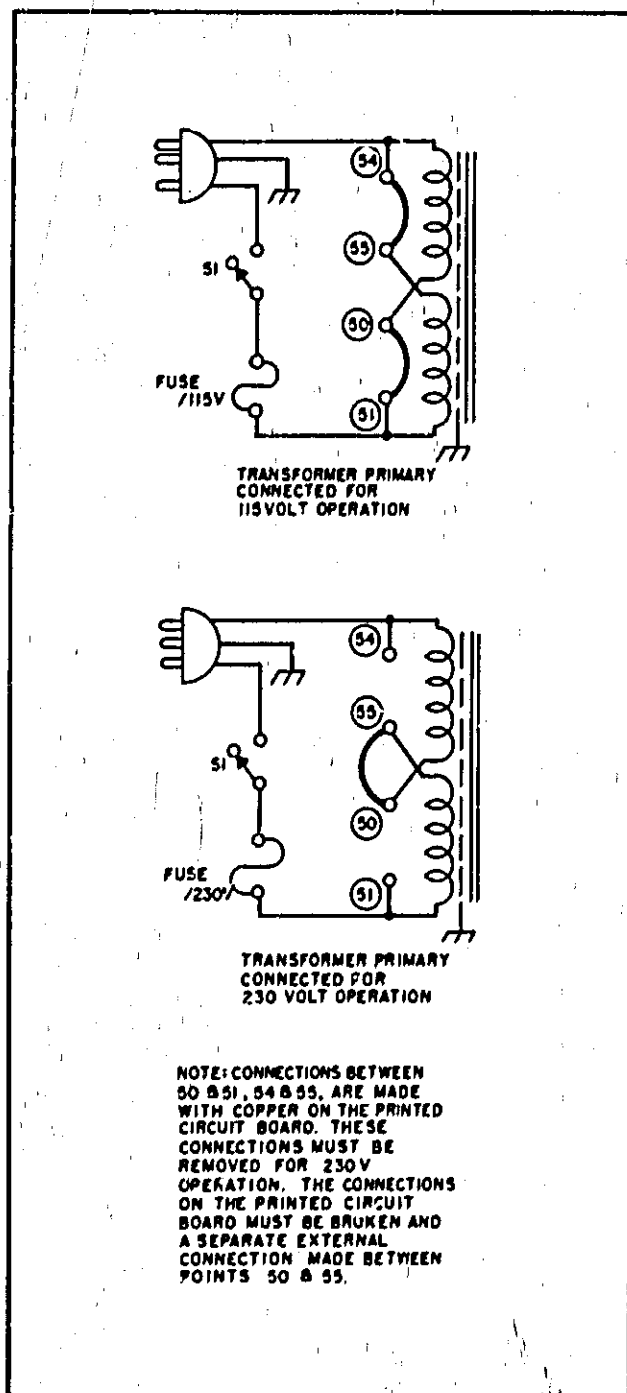

Figure 2-4. Primary Connections

Instrument be used. The original packaging material is reusable. If it is not available, contact your local Hewlett-Packard field office to obtain the materials. This office will also furnish the address of the nearest service office to which the instrument can be shipped. Be sure to attach a tag to the instrument which specifies the owner, model number, full serial number, and service required, or a brief description of the trouble.

SECTION III OPERATING INSTRUCTIONS

3-1 TURN-ON CHECKOUT PROCEDURE

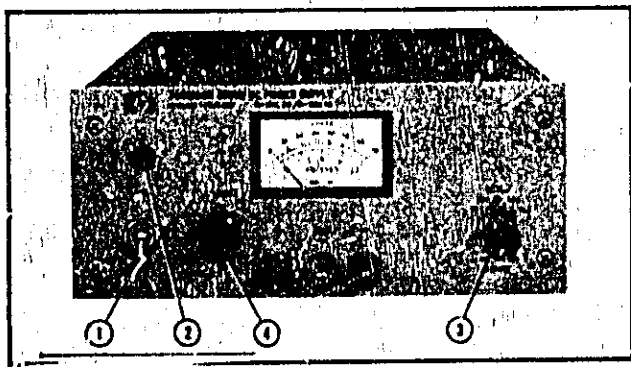

Figure 3-1. Front Panel Controls and Indicators

3-2 The front panel controls and indicators are shown in Figure 3-1. The normal turn-on sequence, is described below:

- A. Set ac power switch to on (1).
- B. Observe that pilot light goes on (2).
- C. Set range switch (3) to desired operating mode and meter switch to desired voltage range.
- D. Adjust coarse and fine voltage controls (4) until desired output voltage is indicated on meter.
- E. Set meter switch to highest current range and short circuit output terminals.
- F. Observe short circuit output current on meter.
- G. Remove short and connect load to output terminals (front or rear).

3-3 OPERATING MODES

3-4 The power supply is designed so that its mode of operation can be selected by making strapping connections between particular terminals on the terminal strip at the rear of the power supply. The terminal designations are stenciled in white on the power supply above their respective terminals. Although the strapping patterns illustrated in this section show the positive terminal grounded, the operator can ground either terminal or operate the power supply up to 300Vdc off ground (floating). The following paragraphs describe the procedures for utilizing the various operational capabilities of the supply. A more theo-

retical description concerning these operational features is contained in Application Note 90 and in various Tech Letters. Copies of these can be obtained from your local Hewlett-Packard field office.

3-5 NORMAL OPERATING MODE

3-6 The power supply is normally shipped with its rear terminal strapping connections arranged for Constant Voltage/Current Limiting, local sensing, local programming, single unit mode of operation. This strapping pattern is illustrated in Figure 3-2. The operator selects a constant voltage output using the front panel controls (local programming, no strapping changes are necessary),

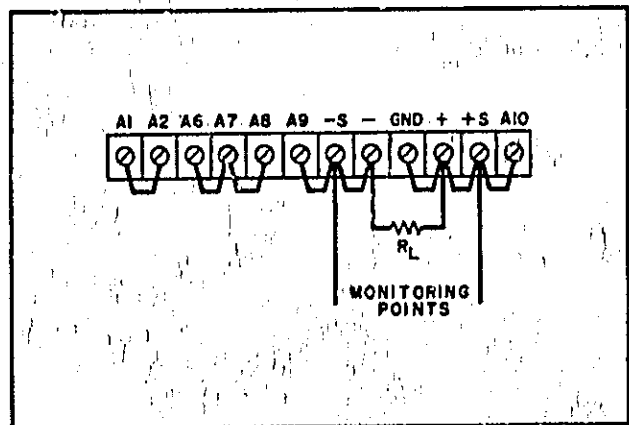

Figure 3-2. Normal Strapping Pattern

3-7 CONSTANT VOLTAGE

3-8 To select a constant voltage output turn on the supply and, with no load connected, adjust the VOLTAGE controls for the desired output voltage. To check the current limit, connect an external ammeter across the output of the supply, turn the VOLTAGE controls fully clockwise, and observe the reading. The current limit is factory adjusted to approximately 100mA above the current rating of the supply. If the existing current limit is not compatible with the anticipated load requirements, the limit can be changed as outlined in the following paragraphs.

3-9 CHANGING CURRENT LIMIT

3-10 The current limit can be varied by adjusting resistor R81, located on the printed wiring board. This adjustment procedure is described in Paragraph 5-74. In Models 6204B and 6206B, the current limit may be reduced to a value lower than that attainable by adjusting R81, by adding an external resistor as shown in Figure 3-3. The approximate value of the external resistance (R_X) can be determined by using the following equation.

$$R_X \approx \frac{1.75}{I_E} - R_I$$

where: I_E = the output current

R_I = the internal current sampling resistance for the particular operating mode to be used.

1.75 = the approximate voltage drop across the internal sampling resistance at the current limit crossover point.

NOTE

The power supply's performance will be somewhat degraded if it is operated too close to (within 100mA) the current limit crossover point.

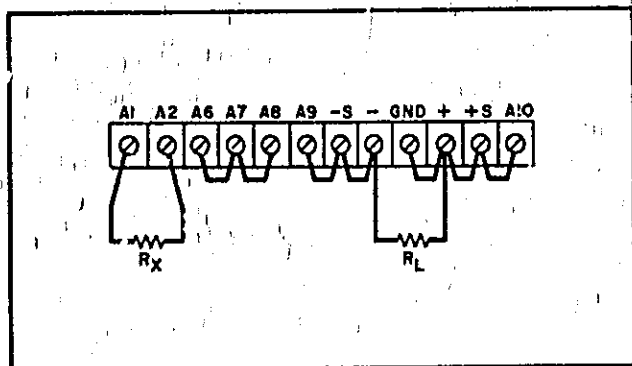

Figure 3-3. Current Limit Alteration

3-11 CONNECTING LOAD

3-12 Each load should be connected to the power supply output terminals using separate pairs of connecting wires. This will minimize mutual coupling effects between loads and will retain full advantage of the low output impedance of the power supply. Each pair of connecting wires should be as short as possible and twisted or shielded to reduce noise pickup. (If shield is used, connect one end to power supply ground terminal and leave the other end unconnected.)

3-13 If load considerations require that the output power distribution terminals be remotely located from the power supply, then the power supply output terminals should be connected to the remote distribution terminals via a pair of twisted or shielded wires and each load separately connected to the remote distribution terminals. For this case, remote sensing should be used (Paragraph 3-25).

3-14 OPERATION BEYOND NORMAL RATED OUTPUT

3-15 Although the supply can deliver greater than the rated output on both the lower and higher voltage ranges without being damaged, it can not be guaranteed to meet all of its performance specifications. Generally when operating the supply in this manner, the output is unstable when connected to a load. When greater than the lower rated voltage is required, the higher voltage range should be used. This range will deliver half as much output current and all specifications will apply as listed in Table 1-1. However, if the line voltage is maintained above its nominal value, the supply will probably operate within specifications above its rated output.

3-16 OPTIONAL OPERATING MODES

3-17 REMOTE PROGRAMMING, CONSTANT VOLTAGE

3-18 The constant voltage output of the power supply can be programmed (controlled) from a remote location if required. Either a resistance or voltage source can be used for the programming device. The wires connecting the programming terminals of the supply to the remote programming device should be twisted or shielded to reduce noise pickup. The VOLTAGE controls on the front panel are disabled according to the following procedures.

3-19 Resistance Programming (Figure 3-4). In this mode, the output voltage will vary at a rate determined by the programming coefficient (200 ohms per Volt for Model 6204B and 6205B or 300 ohms per Volt for Model 6206B). The output voltage will increase by 1 Volt for each 200 ohms (or 300 ohms) added in series with the programming terminals. The programming accuracy is 1% of the programmed voltage. If greater programming accuracy is required, it may be achieved by changing resistor R13 as outlined in Section V.

3-20 The output voltage of the power supply should be zero Volts \pm 20 millivolts when zero ohms is connected across the programming terminals. If a zero ohm voltage closer than this is required, it may be achieved by changing resistor R6 or R8 as described in Section V.

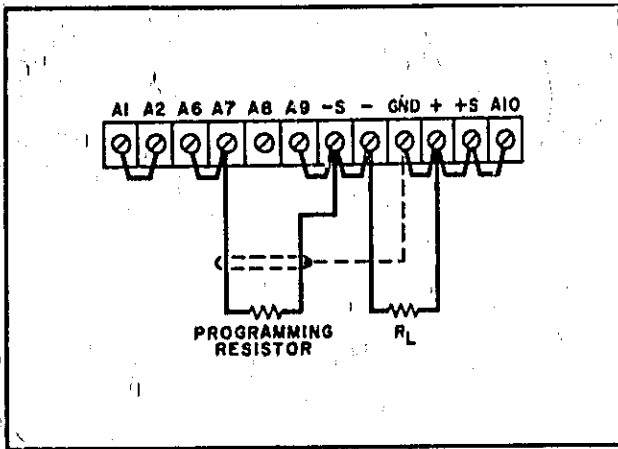

Figure 3-1. Remote Resistance Programming

3-21 To maintain the stability and temperature coefficient of the power supply, use programming resistors that have stable, low noise, and low temperature (less than 30ppm per degree Centigrade) characteristics. A switch can be used in conjunction with various resistance values in order to obtain discrete output voltages. The switch should have make-before-break contacts to avoid momentarily opening the programming terminals during the switching interval.

3-22 Voltage Programming (Figure 3-5). Employ the strapping pattern shown on Figure 3-5 for voltage programming. In this mode, the output voltage will vary in a 1 to 1 ratio with the programming voltage (reference voltage) and the load on the programming voltage source will not exceed 25 microamperes.

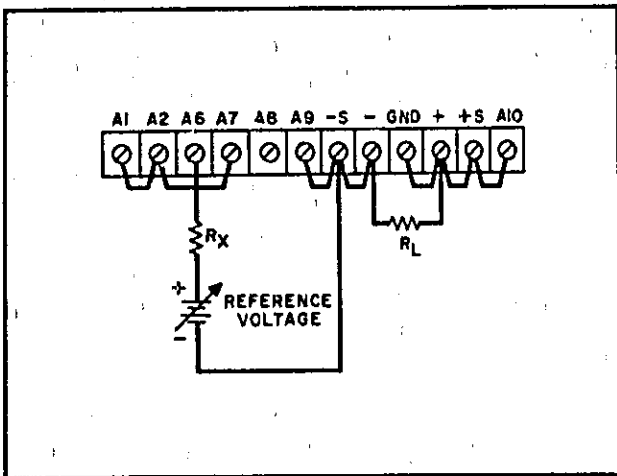

Figure 3-5. Remote Voltage Programming

3-23 The impedance (R_x) looking into the external

programming voltage source should be approximately 1000 ohms if the temperature and stability specifications of the power supply are to be maintained. The programming accuracy is 1% of the programmed voltage.

3-24 Methods of voltage programming with gain are discussed in Application Note 90, Power Supply Handbook; available at no charge from your local Sales Office.

3-25 REMOTE SENSING (See Figure 3-6)

3-26 Remote sensing is used to maintain good regulation at the load and reduce the degradation of regulation which would occur due to the voltage drop in the leads between the power supply and the load. Remote sensing is accomplished by utilizing the strapping pattern shown in Figure 3-6. The power supply should be turned off before changing strapping patterns. The leads from the +S terminals to the load will carry less than 10 milliamperes of current, and it is not required that these leads be as heavy as the load leads. However, they must be twisted or shielded to minimize noise pick-up.

CAUTION

Observe polarity when connecting the sensing leads to the load.

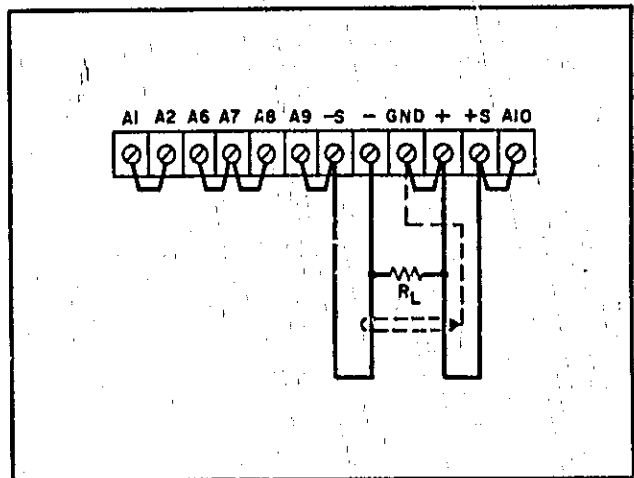

Figure 3-6. Remote Sensing

3-27 For reasonable load lead lengths, remote sensing greatly improves the performance of the supply. However, if the load is located a considerable distance from the supply, added precautions must be observed to obtain satisfactory operation. Notice that the voltage drop in the load leads sub-

tracts directly from the available output voltage and also reduces the amplitude of the feedback error signals that are developed within the unit. Because of these factors it is recommended that the drop in each load lead not exceed 1 Volt. If a larger drop must be tolerated, please consult a sales engineer.

NOTE

Due to the voltage drop in the load leads, it may be necessary to readjust the current limit in the remote sensing mode.

3-28 Another factor that must be considered is the inductance of long load leads which could affect the stability of the feedback loop and cause oscillation. In these cases, it is recommended that the output capacitor (C20) be physically removed from the power supply and placed across the output terminals.

3-29 Although the strapping patterns shown in Figures 3-4 and 3-5 employ local sensing, notice that it is possible to operate a power supply simultaneously in the remote sensing and the remote programming modes.

3-30 SERIES OPERATION

3-31 Normal Series Connections (Figure 3-7). Two or more power supplies can be operated in series to obtain a higher voltage than that available from a single supply. When this configuration is used, the output voltage is the sum of the volt-

ages of the individual supplies. Each of the individual supplies must be adjusted in order to obtain the total output voltage. The power supply contains a protective diode connected internally across the output which protects the supply if one power supply is turned off when its series partner(s) is on.

3-32 Auto-Series Connections (Figure 3-8). The Auto-Series configuration is used when it is desirable to have the output voltage of each of the series connected supplies vary in accordance with the setting of a control unit. The control unit is called the master; the controlled units are called slaves. At maximum output voltage, the voltage of the slaves is determined by the setting of the front panel VOLTAGE control on the master. The master supply must be the most positive supply of the series. The current limit settings of all series

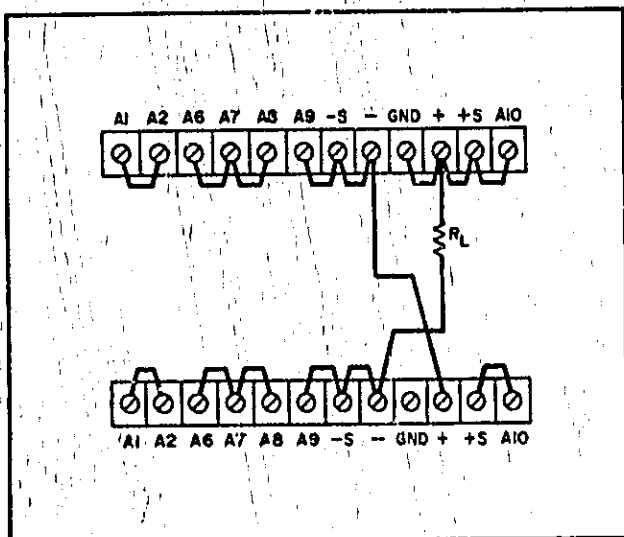

Figure 3-7. Normal Series Connections

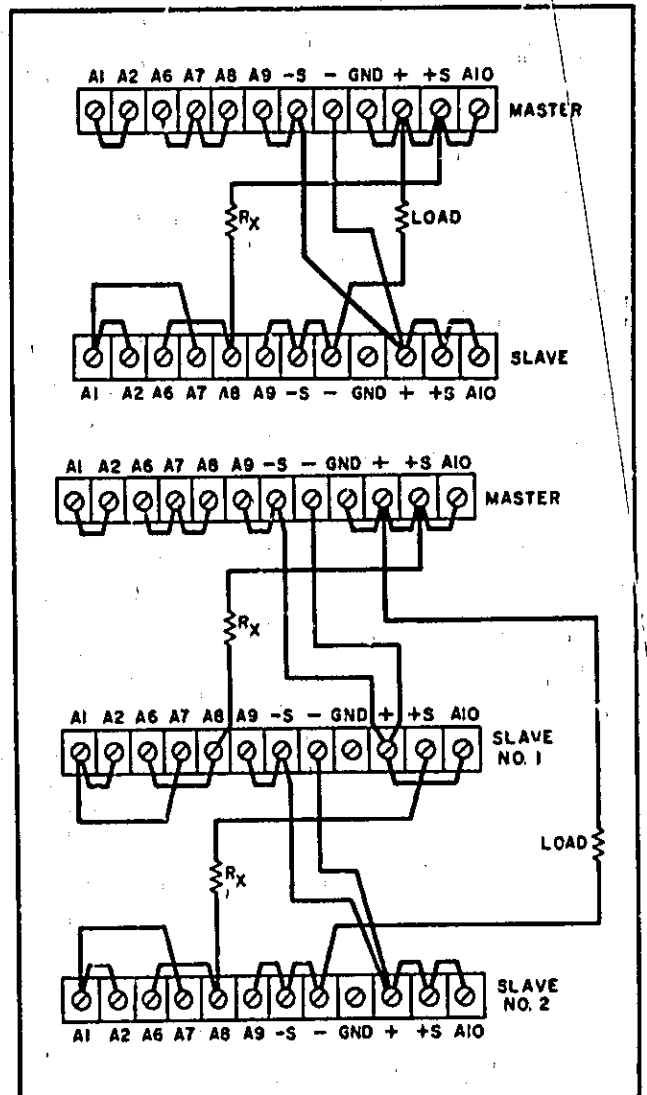

Figure 3-8. Auto-Series, Two and Three Units

units are effective and the current limit for the entire configuration is equal to the lowest current limit setting. If any of the settings are too low, automatic crossover to current limiting operation will occur and the output voltage will drop. Remote sensing and programming can be used; however, the strapping arrangements shown in the applicable figures show local sensing and programming.

3-33 In order to maintain the temperature coefficient and stability specifications of the power supply, the external resistors (R_x) shown in Figure 3-8 should be stable, low noise, low temperature coefficient (less than 30ppm per degree Centigrade) resistors. The value of each resistor is dependant on the maximum voltage rating of the master supply. The value of R_x is this voltage divided by the voltage programming current of the slave supply ($1/K_p$ where K_p is the voltage programming coefficient). The voltage contribution of the slave is determined by its voltage control setting.

3-34 Auto-Parallel. The strapping patterns for Auto-Parallel operation of two and three power supplies are shown in Figure 3-9. Auto-Parallel operation permits equal current sharing under all load conditions, and allows complete control of the output current from one master power supply. The output current of each slave will be approximately equal to the master's regardless of the load conditions. Because the output current controls of each slave are operative, they should be set to maximum to avoid having the slave revert to constant current operation; this would occur if the master output current setting exceeded the slave's.

3-35 AUTO-TRACKING OPERATION (See Figure 3-10)

3-36 The Auto-Tracking configuration is used when it is necessary that several different voltages referred to a common bus, vary in proportion to the setting of a particular instrument (the control or master). A fraction of the master's output voltage

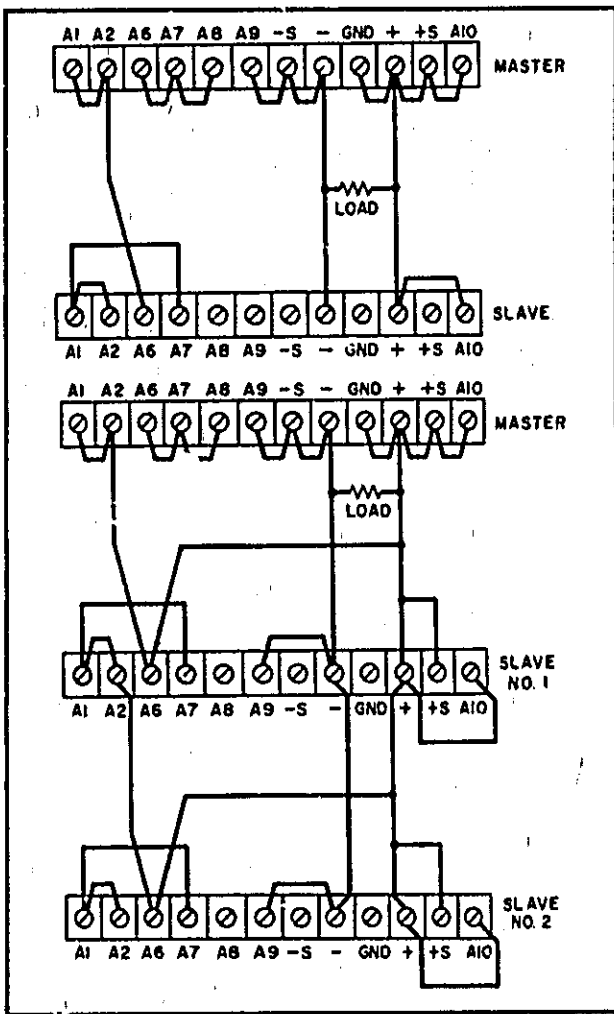

Figure 3-9. Auto-Parallel, Two and Three Units

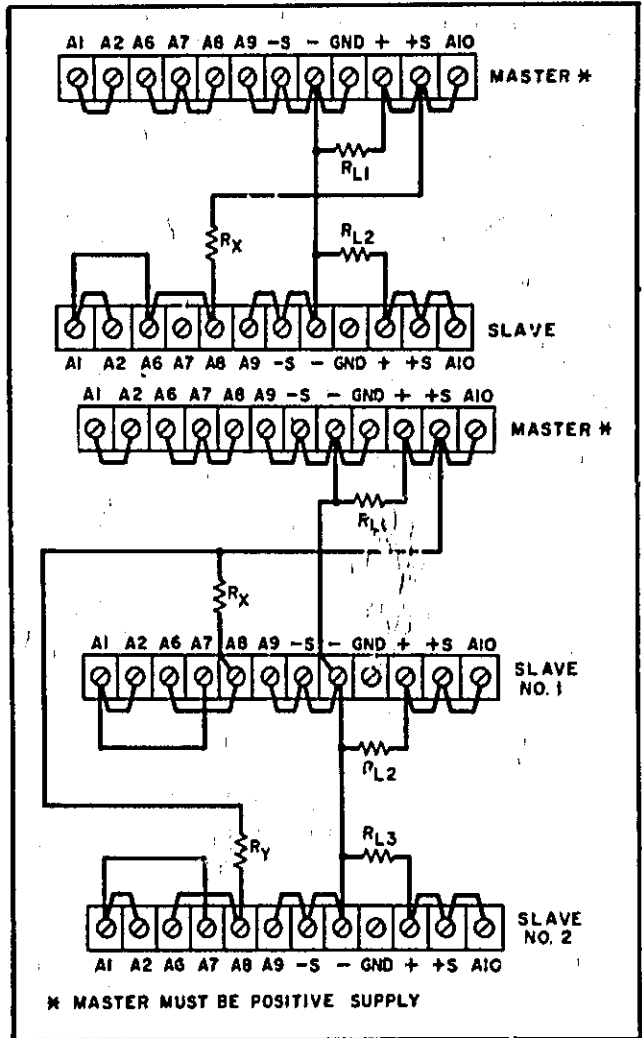

Figure 3-10. Auto-Tracking, Two and Three Units

is fed to the comparison amplifier of the slave supply, thus controlling the slave's output. The master must have the largest output voltage of any power supply in the group (must be the most positive supply in the example shown on Figure 3-10).

3-37 The output voltage of the slave is a percentage of the master's output voltage, and is determined by the voltage divider consisting of R_X (or R_X and R_Y) and the voltage control of the slave supply, R_p , where:

$$E_S = \frac{EMRP}{R_X + R_p}$$

Turn-on and turn-off of the power supplies is controlled by the master. Remote sensing and programming can be used; although the strapping patterns for these modes show only local sensing and programming. In order to maintain the temperature coefficient and stability specifications of the power supply, the external resistors should be stable, low noise, low temperature (less than 30ppm per °C) resistors.

3-38 SPECIAL OPERATING CONSIDERATIONS

3-39 PULSE LOADING

3-40 The power supply will automatically cross over from constant voltage to constant current operation in response to an increase (over the preset limit) in the output current. Although the preset limit may be set higher than the average output current high peak currents (as occur in pulse loading) may exceed the preset current limit and cause crossover to occur. If this crossover limiting is not desired, set the preset limit for the peak requirement and not the average.

3-41 OUTPUT CAPACITANCE

3-42 An internal capacitor, across the output terminals of the power supply, helps to supply high-current pulses of short duration during constant voltage operation. Any capacitance added externally will improve the pulse current capability, but will decrease the safety provided by the current limiting circuit. A high-current pulse may damage load components before the average output current is large enough to cause the current limiting circuit to operate.

3-43 REVERSE VOLTAGE LOADING

3-44 A diode is connected across the output terminals. Under normal operating conditions, the diode is reverse biased (anode connected to negative terminal). If a reverse voltage is applied to the output terminals (positive voltage applied to negative terminal), the diode will conduct, shunting current across the output terminals and limiting the voltage to the forward voltage drop of the diode. This diode protects the series transistors and the output electrolytic capacitors.

3-45 REVERSE CURRENT LOADING

3-46 Active loads connected to the power supply may actually deliver a reverse current to the power supply during a portion of its operating cycle. An external source cannot be allowed to pump current into the supply without loss of regulation and possible damage to the output capacitor. To avoid these effects, it is necessary to preload the supply with a dummy load resistor so that the power supply delivers current through the entire operating cycle of the load device.

SECTION IV PRINCIPLES OF OPERATION

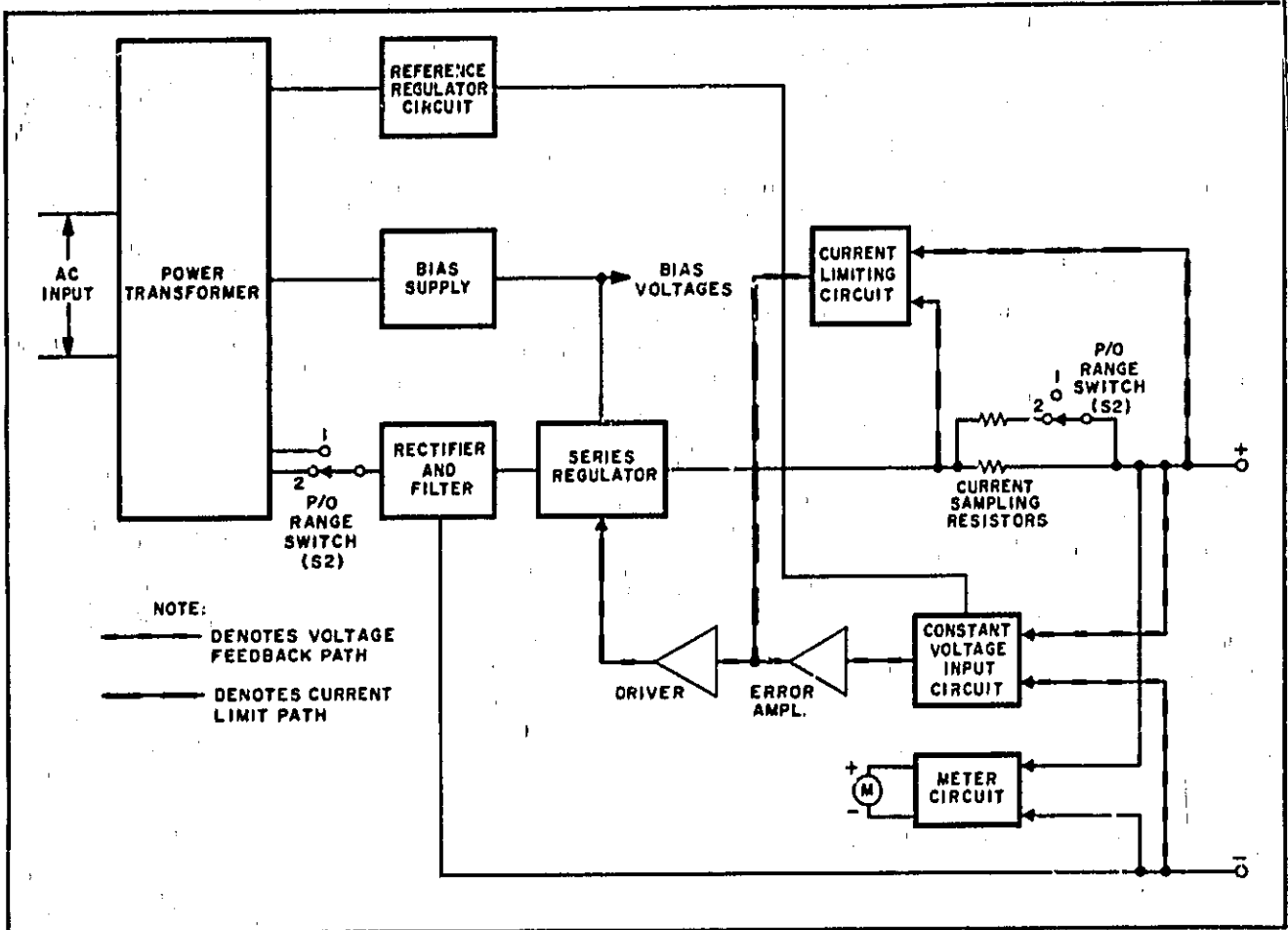

Figure 4-1. Overall Block Diagram

4-1 OVERALL DESCRIPTION

4-2 The major circuits of the power supply are shown on the overall block diagram Figure 4-1.

4-3 The ac line voltage is first applied to the power transformer. The tap for the appropriate voltage range is selected by S2. The input is then rectified and filtered. This raw dc is then fed to the series regulator which alters its conduction to obtain the proper regulated dc output voltage.

4-4 Any changes in output voltage are felt by the constant voltage comparator which compares a portion of the output with a fixed reference voltage. If a difference exists, the comparator circuit sends

an error signal to the series regulator via the error amplifier and driver stages. This error signal changes the conduction of the series regulator so that a constant output voltage is maintained,

4-5 Changes in output current are reflected in the voltage drop across the current sampling resistor network. If this voltage drop exceeds a preset limit, the current limit transistor conducts, sending a turn-down signal to the series regulator via the driver. This signal changes the conduction of the series regulator so that the output current is limited to the proper value.

4-6 The reference circuit provides stable reference voltages used in the constant voltage com-

parator and current limit circuits. The bias circuit provides the less critical bias voltages used in the supply.

4-7 The meter circuit provides a continuous indication of output voltage or current in both ranges.

4-8 DETAILED CIRCUIT ANALYSIS

4-9 FEEDBACK LOOP

4-10 The feedback loop functions continuously to keep the output voltage constant during normal operation of the supply. For purposes of this discussion, assume that the output voltage instantaneously rises (goes positive) due to a variation in the external load circuit. Note that the change may be in the form of a slow rise in the output voltage or a positive going ac signal. An ac signal is coupled to summing point A6 through capacitor C1 and a dc voltage is coupled to A6 through R10.

4-11 The rise in output voltage causes the voltage at A6 and thus the base of Q1A to decrease (go negative). Q1A now decreases its conduction and its collector voltage rises. The positive going error voltage is amplified and inverted by Q3 and fed to the base of the series transistor(s) via emitter follower Q4. The negative going input causes the series transistor(s) to decrease its conduction so that it drops more of the line voltage, reducing the output voltage to its original level.

4-12 If the external load resistance decreases to a certain crossover point, the supply will operate in the current limiting mode. In the current limit mode, Q10 conducts sending a negative going, turn-down signal to the series regulator via driver Q4.

4-13 SERIES REGULATOR

4-14 The series regulator consists of transistor stage Q7 (and Q6 on Model 6206B). The regulator serves as a series control element by altering its conduction so that the output voltage is kept constant and the current limit is never exceeded. The conduction of the transistor(s) is controlled by the feedback voltage obtained from driver Q4. Diode CR11, connected across the regulator circuit, protects the series transistor(s) against reverse voltages that could develop across it during parallel or auto-parallel operation if one supply is turned on before the other.

4-15 CONSTANT VOLTAGE COMPARATOR

4-16 The circuit consists of the coarse and fine programming resistors (R10A and R10B), and a differential amplifier stage (Q1 and associated com-

ponents). Transistor Q1 consists of two transistors housed in a single package. The transistors have matched characteristics minimizing differential voltages due to mismatched stages. Moreover, drift due to thermal differentials is minimized, since both transistors operate at essentially the same temperature.

4-17 The constant voltage comparator continuously compares a fixed reference voltage with a portion of the output voltage and, if a difference exists, produces an error voltage whose amplitude and phase is proportional to the difference. The error output is fed back to the series regulator, through the (mixer) error and driver amplifiers. The error voltage changes the conduction of the series regulator which, in turn, alters the output voltage so that the difference between the two input voltages applied to the differential amplifier is reduced to zero. The above action maintains the output voltage constant.

4-18 Stage Q1B of the differential amplifier is connected to a common (+S) potential through impedance equalizing resistor R5. Resistors R6 and R8 are used to zero bias the input stage, offsetting minor base-to-emitter voltage differences in Q1. The base of Q1A is connected to a summing point at the junction of the programming resistors and the current pullout resistors, R12 and R13. Instantaneous changes in output voltage result in an increase or decrease in the summing point potential. Q1A is made to conduct more or less, in accordance with summing point voltage change. The resultant output error voltage is fed back to the series regulator via the remaining components of the feedback loop. Resistor R1, in series with the base Q1A, limits the current through the programming resistors during rapid voltage turn-down. Diodes CR1 and CR2 form a limiting network which prevent excessive voltage excursions from over driving stage Q1A. Capacitor C1, shunting the programming resistors, increases the high frequency gain of the input amplifier. Resistor R13, shunting pullout resistor R12, is factory selected so that all of the +6.2 Volt reference is dropped across R12 and R13. Linear constant voltage programming is assured with a constant current flowing through R10. C20 stabilizes the feedback loop and may be removed to avoid current surges and increase the programming speed.

4-19 ERROR AMPLIFIER AND DRIVER

4-20 The error and driver amplifiers amplify the error signal from the constant voltage comparator circuit to a level sufficient to drive the series regulator transistor(s). Driver Q4 also receives a current limiting input if Q10, the current limiting transistor, conducts.

4-21 Stage Q3 contains a feedback equalizer network, C5 and R30, which provides for high frequency roll off in the loop gain in order to stabilize the feedback loop. Q17 establishes a stable emitter bias potential for error amplifier Q3. Emitter follower transistor(s) Q4 (and Q5) serves as the driver (and predriver) element for the series regulator.

4-22 CURRENT LIMIT CIRCUIT

4-23 The current limit circuit limits the output current to a preset value determined by the setting of R81. Switch S2B selects the proper sampling resistance to maintain an equal voltage drop across the current sampling network in both ranges.

4-24 When S2 is set to the 20 Volt position, R54 and R55 are connected in parallel. When S2 is set to the 40 Volt position, the current sampling network consists solely of R54. Note that in the twenty Volt range, twice as much current can be delivered as in the forty Volt range. Since the twenty Volt range has a sampling resistance equal to half the value of that for the forty Volt range, an equal sampling resistor voltage drop is obtained in both ranges. This also applies to S2 in the 6206B.

4-25 R81 sets the bias of Q10, and thus, the threshold point at which Q10 conducts and current limiting begins. If this threshold is exceeded, Q10 begins to conduct, forward biasing CR16 and sending a turn-down signal to the series regulator via the driver. If the current through the current sampling network decreases below the threshold point, Q10 turns off and no longer affects the operation of the supply.

4-26 REFERENCE CIRCUIT

4-27 The reference circuit (see schematic) is a feedback power supply similar to the main supply. It provides stable reference voltages which are used throughout the unit. The reference voltages are all derived from smoothed dc obtained from the full wave rectifier (CR22 and CR23) and filter capacitor C10. The +6.2 and -6.2 voltages, which are used in the constant voltage input circuit for comparison purposes, are developed across temperature compensated Zener diodes VR1 and VR2. Resistor R43 limits the current through the Zener diodes to establish an optimum bias level.

4-28 The reference circuit consists of series regulating transistor Q9 and error amplifier Q8. Output voltage changes are detected by Q8 whose base is connected to the junction of a voltage divider (R41, R42) connected directly across the supply. Any error signals are amplified and inverted by Q8 and applied to the base of series transistor Q9. The series element then alters its conduction in the direction, and by the amount, necessary to maintain the voltage across VR1 and VR2 constant. Resistor R46, the emitter resistor for Q8, is connected in a manner which minimizes changes in the reference voltage caused by variations in the input line. Output capacitor C9 stabilizes the regulator loop.

4-29 METER CIRCUIT (Figure 4-2)

4-30 The meter circuit provides continuous indications of output voltage or current on a single multiple range meter. The meter can be used either as a voltmeter or an ammeter depending upon the position of the METER section of switch S2 on the front panel of the supply. This switch also selects one of two meter ranges on each scale. The meter circuit consists of METER-RANGE switch S2, various multiplying resistors and the meter movement.

4-31 When measuring voltage, the meter is placed directly across the output of the supply between the +S and -S terminals. With the METER section of S2A in the higher voltage position (terminals A2 and A10) multiplying resistors R60, R61, R72, and the parallel combination of R73 and R87, are in series with the meter. For low output voltages, the METER switch S2A can be set to the first position (terminals 1 and 9) which removes R61 from its series position allowing a larger percentage of the output voltage to be felt across the meter.

4-32 When measuring current, the meter circuit is connected across the current sampling resistor network as shown on Figure 4-2 and indicates the output current that flows through the network. The RANGE section S2B connects the appropriate resistance in series with the meter so that its maximum deflection range is full-scale in the high current (low voltage) operating mode and half-scale in the low current (high voltage) operating mode. This circuit obviates the need for a dual current scale which would be necessary since the voltages dropped across the current sampling network in both operating modes are equal for proportional currents.

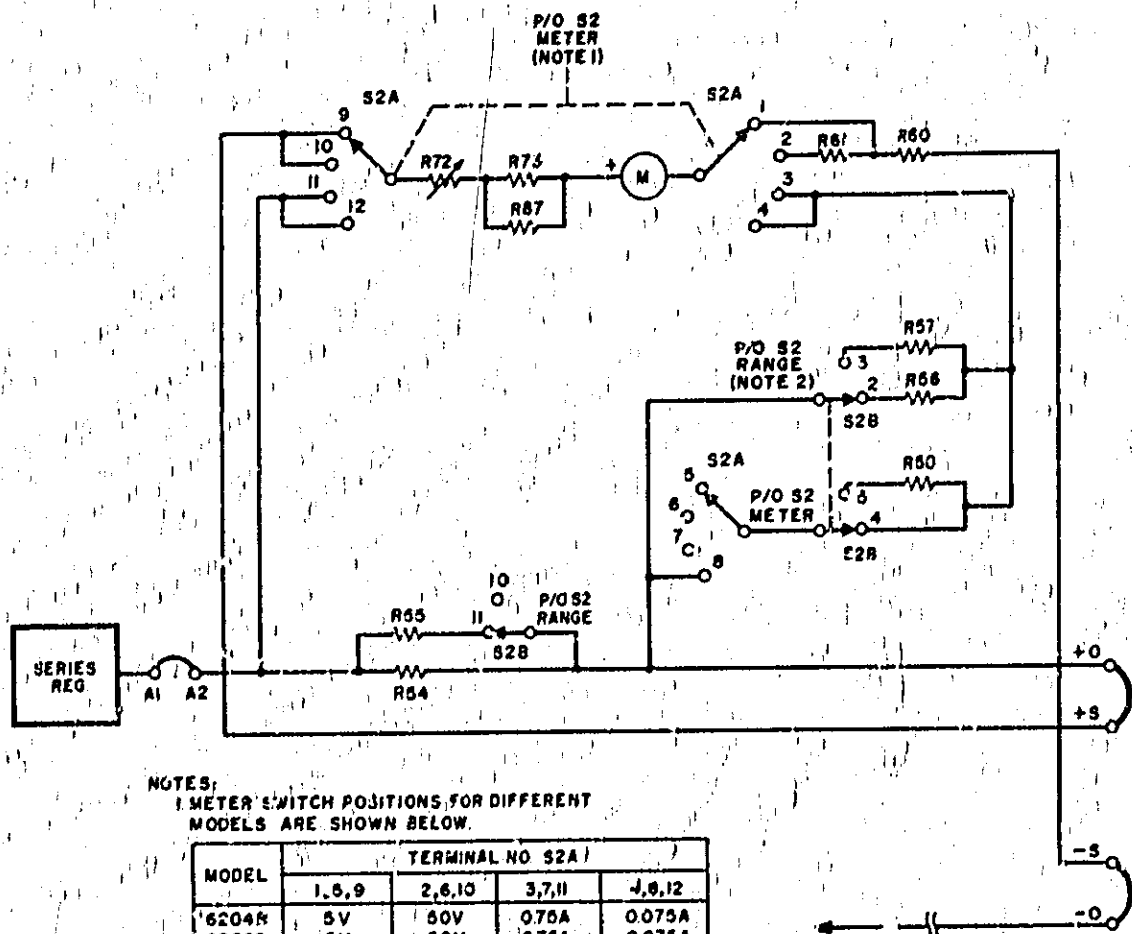

NOTES:
1. METER SWITCH POSITIONS FOR DIFFERENT MODELS ARE SHOWN BELOW.

MODEL	TERMINAL NO S2A			
	1,5,9	2,6,10	3,7,11	4,8,12
6204R	5V	50V	0.75A	0.075A
6205B	5V	50V	0.75A	0.075A
6206B	7V	70V	1.20A	0.120A

2. RANGE SWITCH POSITIONS FOR DIFFERENT MODELS ARE SHOWN BELOW.

MODEL	TERMINAL NO. S2B	
	2,4,11	3,5,10
6204B	20V	140V
6205B	20V	40V
6206B	30V	80V

Figure 4-2. Multiple Range Meter Circuit, Simplified Schematic

SECTION V MAINTENANCE

5-1 INTRODUCTION

5-2 Upon receipt of the power supply, the performance check (Paragraph 5-10) should be made. This check is suitable for incoming inspection. If a fault is detected in the power supply while making the performance check or during normal operation, proceed to the troubleshooting procedures (Paragraph 5-48). After troubleshooting and repair (Paragraph 5-58), perform any necessary adjustments and calibrations (Paragraph 5-60). Before returning the power supply to normal operation, repeat the performance check to ensure that the fault has been properly corrected and that no other faults exist. Before doing any maintenance checks, turn-on power supply, allow a half-hour warm-up, and read the general information regarding measurement techniques (Paragraph 5-3).

5-3 GENERAL MEASUREMENT TECHNIQUES

5-4 The measuring device must be connected across the sensing leads of the supply or as close to the output terminals as possible when measuring the output impedance, transient response, regulation, or ripple of the power supply in order to achieve valid measurements. A measurement made across the load includes the impedance of the leads to the load and such lead lengths can easily have an impedance several orders of magnitude greater than the supply impedance, thus invalidating the measurement.

5-5 The monitoring device should be connected to the +S and -S terminals (see Figure 3-2) or as shown in Figure 5-1. The performance characteristics should never be measured on the front terminals if the load is connected across the rear terminals. Note that when measurements are made at the front terminals, the monitoring leads are connected at A, not B, as shown in Figure 5-1. Failure to connect the measuring device at A will result in a measurement that includes the resistance of the leads between the output terminals and the point of connection.

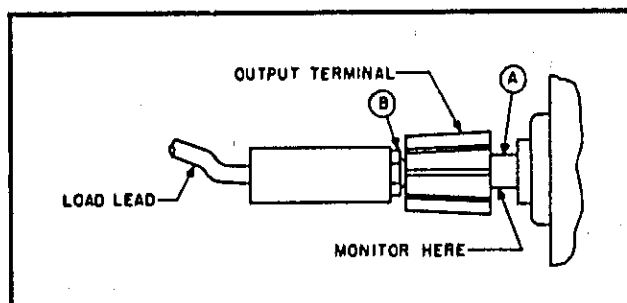

Figure 5-1. Front Panel Terminal Connections

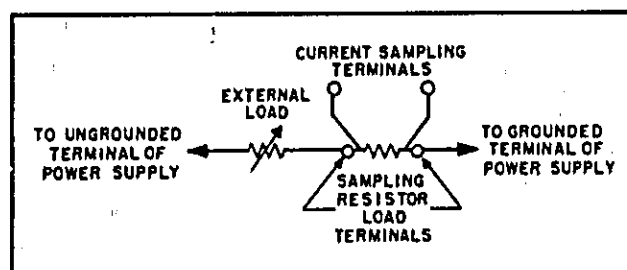

Figure 5-2. Output Current Measurement Technique

5-6 For output current measurements, the current sampling resistor should be a four-terminal resistor. The four terminals are connected as shown in Figure 5-2. In addition, the resistor should be of the low noise, low temperature coefficient (less than 30ppm/ $^{\circ}$ C) type and should be used at no more than 5% of its rated power so that its temperature rise will be minimized.

5-7 When using an oscilloscope, ground one terminal of the power supply and then ground the case of the oscilloscope to this same point. Make certain that the case is not also grounded by some other means (power line). Connect both oscilloscope input leads to the power supply ground terminal and check that the oscilloscope is not exhibiting a ripple or transient due to ground loops, pick-up, or other means.

5-8 TEST EQUIPMENT REQUIRED

5-9 Table 5-1 lists the test equipment required to perform the various procedures described in this Section.

NOTE

A satisfactory substitute for a differential voltmeter is to arrange a reference voltage source and null detector as shown in Figure 5-3. The reference voltage source is adjusted so that the voltage difference between the supply being measured and the reference voltage will have the required resolution for the measurement being made. The voltage difference will be a function of the null detector that is used. Examples of satisfactory null detectors are: Q 419A null detector, a dc coupled oscilloscope utilizing differential input, or a 50mV meter movement with a 100 division scale. For the latter, a 2mV change in voltage will result in a meter deflection of four divisions.

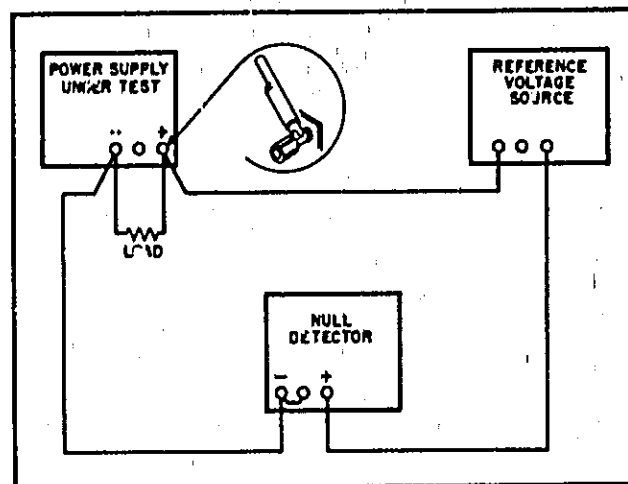

Figure 5-3. Differential Voltmeter Substitute, Test Setup

CAUTION

Care must be exercised when using an electronic null detector in which one input terminal is grounded to avoid ground loops and circulating currents.

Table 5-1. Test Equipment Required

TYPE	REQUIRED CHARACTERISTICS	USE	RECOMMENDED MODEL
Differential Voltmeter	Sensitivity: 1mV full scale (min.). Input impedance: 10 megohms (min.).	Measure dc voltages; calibration procedures	Q 3420 (See Note)
Variable Voltage	Range: 90-130 Volts Equipped with voltmeter accurate within 1 Volt.	Vary ac input	----
AC Voltmeter	Accuracy: 2%. Sensitivity: 1mV full scale deflection (min.).	Measure ac voltage and ripple	Q 403 B
Oscilloscope	Sensitivity: 10 μ V/cm. Differential input.	Display transient response waveforms	Q 140 A plus 1402A plug in.
Oscillator	Range: 5Hz to 600kHz Accuracy: 2%	Impedance Checks	Q 200 CD
DC Voltmeter	Accuracy: 1%. Input resistance: 20,000 ohms/Volt (min.).	Measure dc voltages	Q 412 A
Repetitive Load Switch	Rate: 60-400Hz, 2 μ sec rise and fall time.	Measure transient response	See Figure 5-6

Table 5-1. Test Equipment Required (Continued)

TYPE	REQUIRED CHARACTERISTICS	USE	RECOMMENDED MODEL
Resistor	6204B, 6205B; 133 Ω , \pm 10% 15W 6206B; 120 Ω , \pm 10% 15W	Load Resistor, HIGH range	----
Resistor	Value: 5 Ω , 0.5%, 4.5 Watts, 20ppm, 4-Terminal.	Current sampling	R54 or R55, Section VI
Resistor	Value: 6204B and 6205B, 28 Ω , 2W (min.). 6206B, 27 Ω , 10W (min.).	Load resistor, low range	----
Resistor	1K Ω \pm 1%, 2 Watt non-induc- tive	Measure impedance	----
Resistor	100 ohms, \pm 5%, 10 Watt	Measure impedance	----
Resistor	Value: See Paragraph 5-67. \pm 0.1%, 5 Watt	Calibrate programming current	----
Capacitor	500 μ f, 50WVdc	Measure impedance	----
Decade Resistance Box	Range: 0-150K (min.). Accuracy: 0.1% plus 1 ohm Make-before-break contacts.	Measure programming coefficients	----

5-10 PERFORMANCE TEST

5-11 The following test can be used as an incoming inspection check and appropriate portions of the test can be repeated either to check the operation of the instrument after repairs or for periodic maintenance tests. The tests are performed using a 115Vac 60Hz, single phase input power source. If the correct result is not obtained for a particular check, do not adjust any controls; proceed to troubleshooting (Paragraph 5-48).

NOTE

For Model 6205B supplies, the following performance checks should be performed twice in order to check both independent sections of the supply.

5-12 CONSTANT VOLTAGE TESTS

5-13 For Constant Voltage measurements, the measuring device must be connected across the rear sensing terminals of the supply in order to achieve valid indications. A measurement made across the load includes the impedance of the

leads to the load and such lead lengths can easily have an impedance several orders of magnitude greater than the supply impedance (1 milliohm at dc), thus invalidating the measurement.

5-14 To avoid mutual coupling effects, each monitoring device must be connected directly to the sensing terminals by separate pairs of leads. The load resistor is connected across the output terminals and must be selected according to the output voltage and current of the supply. When measuring the constant voltage performance specifications, the CURRENT controls should be set well above the maximum output current which the supply will draw, since the onset of constant current action will cause a drop in output voltage, increased ripple, and other performance changes not properly ascribed to the constant voltage operation of the supply.

5-15 Voltage Output and Voltmeter Accuracy. To check the output voltage, proceed as follows:

- a. Connect 133 ohm load resistor (120 ohms for Model 6206B) across rear output terminals of supply.
- b. Connect differential voltmeter across +S and -S terminals of supply observing correct polarity.

- c. Set METER switch to highest voltage range and RANGE switch to highest voltage mode and turn on supply.
- d. Adjust VOLTAGE controls until front panel meter indicates exactly the maximum rated output voltage.
- e. Differential voltmeter should indicate maximum rated output voltage within 3%.

5-16 Output Current and Ammeter Accuracy. To check the output current, proceed as follows:

- a. Connect test setup shown in Figure 5-4.
- b. Set METER switch to highest current range and RANGE switch to low voltage mode.
- c. Turn on supply and adjust VOLTAGE controls until front panel meter indicates exactly 600 mA (1 Ampere for Model 6206B supplies).
- d. Differential voltmeter should read $3 \pm 0.09\text{Vdc}$.

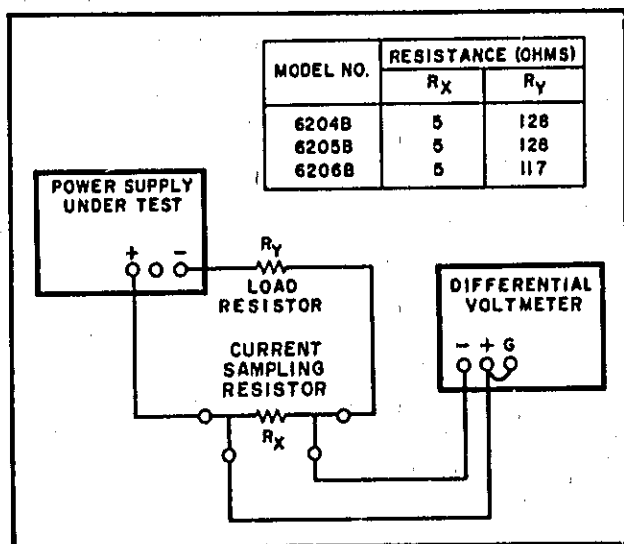

Figure 5-4. Output Current, Test Setup

5-17 Load Regulation.

Definition: The change ΔE_{OUT} in the static value of dc output voltage resulting from a change in load resistance from open circuit to a value which yields maximum rated output current (or vice versa).

5-18 To check the constant voltage load regulation, proceed as follows:

- a. Connect test setup as shown in Figure 5-5.
- b. Turn CURRENT controls fully clockwise.
- c. Turn-on supply and adjust VOLTAGE controls until front panel voltmeter indicates exactly the maximum rated output voltage.
- d. Read and record voltage indicated on dif-

ferential voltmeter.

- e. Disconnect load resistors.
- f. Reading on differential voltmeter should not vary from reading recorded in Step d by more than 8mVdc for Models 6204B and 6205B or 10mVdc for Model 6206B supply.

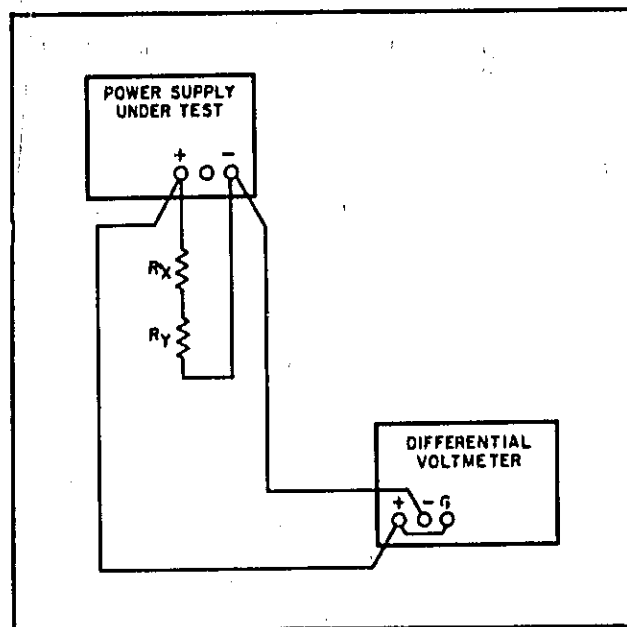

Figure 5-5. Load Regulation, Test Setup

5-19 Line Regulation.

Definition: The change, ΔE_{OUT} in the static value of dc output voltage resulting from a change in ac input voltage over the specified range from low line 10% less than nominal to high line 10% more than nominal or from high line to low line.

5-20 To test the constant voltage line regulation, proceed as follows:

- a. Connect variable auto transformer between input power source and power supply power input.
- b. Turn CURRENT controls fully clockwise.
- c. Connect test setup shown in Figure 5-5.
- d. Adjust variable auto transformer for low line (104Vac).
- e. Set METER switch to highest current range and turn on supply.
- f. Adjust VOLTAGE controls until front panel voltmeter indicates exactly the maximum rated output voltage.
- g. Read and record voltage indicated on differential voltmeter.
- h. Adjust variable auto transformer for high line (126Vac).

1. Reading on differential voltmeter should not vary from reading recorded in Step 7 by more than 8mVdc for Models 6204B and 6205B or 10mVdc for Model 6206B.

5-21 Ripple and Noise.

Definition: The residual ac voltage which is superimposed on the dc output of a regulated power supply. Ripple and noise may be specified and measured in terms of its RMS or (preferably) peak-to-peak value.

Ripple and noise measurement can be made at any input ac line voltage combined with any dc output voltage and load current within rating.

5-22 The amount of ripple and noise that is present on the power supply output is measured either in terms of the RMS or (preferably) peak-to-peak value. The peak-to-peak measurement is particularly important for applications where noise spikes could be detrimental to a sensitive load, such as logic circuitry. The RMS measurement is not an ideal representation of the noise, since fairly high output noise spikes of short duration could be present in the ripple and not appreciably increase the RMS value.

5-23 The technique used to measure high frequency noise or "spikes" on the output of a power supply is more critical than the low frequency ripple and noise measurement technique; therefore the former is discussed separately in Paragraph 5-31.

5-24 **Ripple and Noise Measurements.** Figure 5-6A shows an incorrect method of measuring p-p ripple. Note that a continuous ground loop exists from the third wire of the input power cord of the supply to the third wire of the input power cord of the oscilloscope via the grounded power supply case, the wire between the negative output terminal of the power supply and the vertical input of the scope, and the grounded scope case. Any ground current circulating in this loop as a result of the difference in potential E_G between the two ground points causes an IR drop which is in series with the scope input. This IR drop, normally having a 60Hz line frequency fundamental, plus any pickup on the unshielded leads interconnecting the power supply and scope, appears on the face of the CRT. The magnitude of this resulting noise signal can easily be much greater than the true ripple developed between the plus and minus output terminals of the power supply, and can completely invalidate the measurement.

5-25 The same ground current and pickup problems

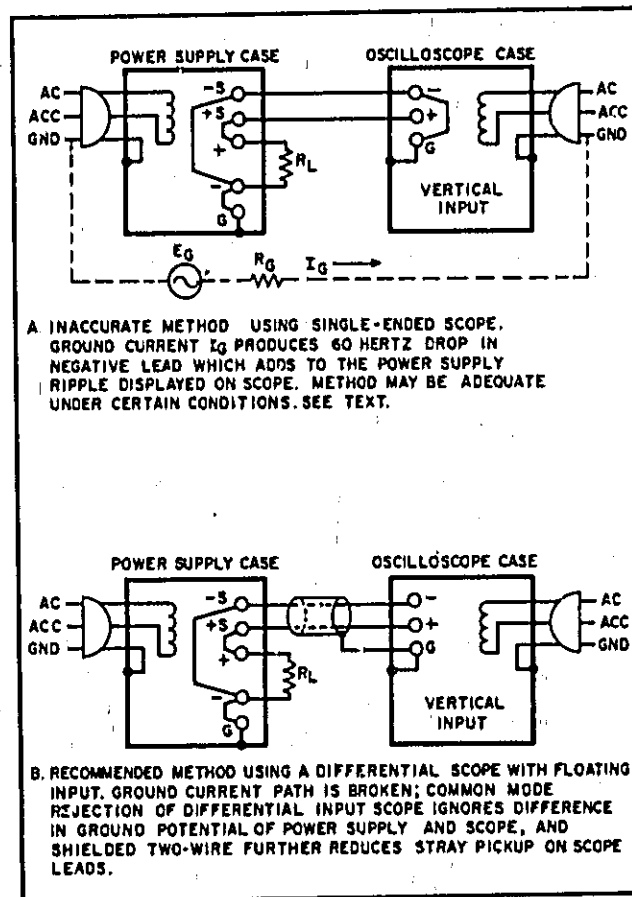

Figure 5-6. CV Ripple and Noise, Test Setup

can exist if an RMS voltmeter is substituted in place of the oscilloscope in Figure 5-6. However, the oscilloscope display, unlike the true RMS meter reading, tells the observer immediately whether the fundamental period of the signal displayed is 8.3 milliseconds (1/120Hz) or 16.7 milliseconds (1/60Hz). Since the fundamental ripple frequency present on the output of an Φ supply is 120Hz (due to full-wave rectification), an oscilloscope display showing a 120Hz fundamental component is indicative of a "clean" measurement setup, while the presence of a 60Hz fundamental usually means that an improved setup will result in a more accurate (and lower) value of measured ripple.

5-26 Although the method shown in Figure 5-6A is not recommended for ripple measurements, it may prove satisfactory in some instances provided certain precautionary measures are taken. One method of minimizing the effects of ground current flow (I_G) is to ensure that both the supply and the test instrument are plugged into the same ac power buss.

5-27 To minimize pick up, a twisted pair or (preferably) a shielded two-wire cable should be used to connect the output terminals of the power supply to the vertical input terminals of the scope. When using a twisted pair, care must be taken that one of the two wires is connected both to the grounded terminal of the power supply and the grounded input terminal of the oscilloscope. When using shielded two-wire cable, it is essential for the shield to be connected to ground at one end only to prevent any ground current flowing through this shield from inducing a signal in the shielded leads.

5-28 To verify that the oscilloscope is not displaying ripple that is induced in the leads or picked up from the grounds, the (+) scope lead should be shorted to the (-) scope lead at the power supply terminals. The ripple value obtained when the leads are shorted should be subtracted from the actual ripple measurement.

5-29 If the foregoing measures are used, the single-ended scope of Figure 5-6A may be adequate to eliminate non-real components of ripple so that a satisfactory measurement can be obtained. However, in stubborn cases or in measurement situations where it is essential that both the power supply case and the oscilloscope case be connected to ground (e.g. if both are rack-mounted), it may be necessary to use a differential scope with floating input as shown in Figure 5-6B. If desired, two single-conductor shielded cables may be substituted in place of the shielded two-wire cable with equal success. Because of its common mode rejection, a differential oscilloscope displays only the difference in signal between its two vertical input terminals, thus ignoring the effects of any common mode signal introduced because of the difference in the ac potential between the power supply case and scope case. Before using a differential input scope in this manner, however, it is imperative that the common mode rejection capability of the scope be verified by shorting together its two input leads at the power supply and observing the trace on the CRT. If this trace is a straight line, the scope is properly ignoring any common mode signal present. If this trace is not a straight line, then the scope is not rejecting the ground signal and must be realigned in accordance with the manufacturer's instructions until proper common mode rejection is attained.

5-30 To check the ripple and noise output, proceed as follows:

- Connect the oscilloscope or RMS voltmeter as shown in Figures 5-6A or 5-6B.
- Adjust VOLTAGE control until front panel meter indicates maximum rated output voltage.
- The observed ripple and noise should be less than $200\mu\text{V}_{\text{rms}}$ and 1mV p-p .

5-31 Noise Spike Measurement. When a high frequency spike measurement is being made, an instrument of sufficient bandwidth must be used; an oscilloscope with a bandwidth of 20MHz or more is adequate. Measuring noise with an instrument that has insufficient bandwidth may conceal high frequency spikes detrimental to the load.

5-32 The test setup illustrated in Figure 5-6A is generally not acceptable for measuring spikes; a differential oscilloscope is necessary. Furthermore, the measurement concept of Figure 5-6B must be modified if accurate spike measurement is to be achieved:

- As shown in Figure 5-7, two coax cables, must be substituted for the shielded two-wire cable.
- Impedance matching resistors must be included to eliminate standing waves and cable ringing, and the capacitors must be connected to block the dc current path.
- The length of the test leads outside the coax is critical and must be kept as short as possible; the blocking capacitor and the impedance matching resistor should be connected directly from the inner conductor of the cable to the power supply terminals.
- Notice that the shields of the power supply end of the two coax cables are not connected to the power supply ground, since such a connection would give rise to a ground current path through the coax shield, resulting in an erroneous measurement.
- Since the impedance matching resistors constitute a 2-to-1 attenuator, — the noise spikes observed on the oscilloscope should be less than 0.5mV p-p instead of 1mV .

5-33 The circuit of Figure 5-7 can also be used for the normal measurement of low frequency ripple and noise; simply remove the four terminating re-

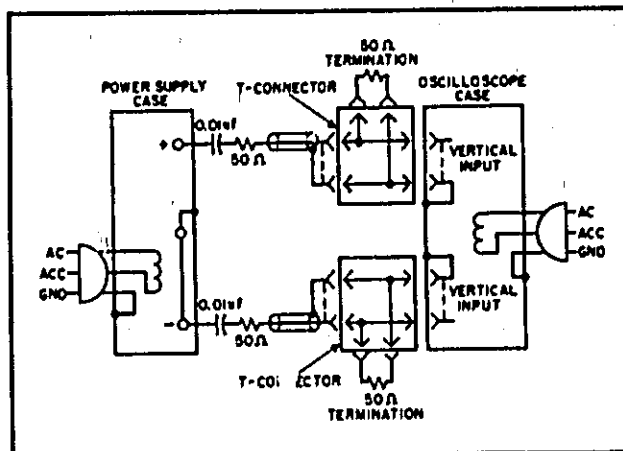

Figure 5-7. CV Noise Spike, Test Setup

sistors and the blocking capacitors and substitute a higher gain vertical plug-in in place of the wide-band plug-in required for spike measurements. Notice that with these changes, Figure 5-7 becomes a two-cable version of Figure 5-6C.

5-34 Transient Recovery Time

Definition: The time "X" for output voltage recovery to within "Y" millivolts of the nominal output voltage following a "Z" Amp step change in load current — where: "Y" is specified as 10 millivolts. The nominal output voltage is defined as the dc level half way between the static output voltage before and after the imposed load change, and "Z" is the specified load current change, which is 5 Amperes.

5-35 A mercury-wetted relay, as connected in the load switching circuit of Figure 5-8 should be used for loading and unloading the supply. When this load switch is connected to a 60Hz ac input, the mercury-wetted relay will open and close 60 times per second. Adjustment of the 25K control permits adjustment of the duty cycle of the load current switching and reduction in jitter of the oscilloscope display.

5-36 The maximum load ratings listed in Figure 5-4 must be observed in order to preserve the mer-

cury-wetted relay contacts. Switching of larger load currents can be accomplished with mercury pool relays; with this technique fast rise times can still be obtained, but the large inertia of mercury pool relays limits the maximum repetition rate of load switching and makes the clear display of the transient recovery characteristic on an oscilloscope more difficult.

5-37 To check the transient recovery time of the supply, proceed as follows:

- Connect test setup shown in Figure 5-8.
- Set METER switch to highest current range and RANGE switch to lowest voltage mode.
- Turn on supply and adjust VOLTAGE controls until front panel meter indicates exactly the maximum rated output current.
- Close line on repetitive load switch set-up.

e. Adjust 25K potentiometer until a stable display is obtained on oscilloscope. Waveform should be within the tolerances shown on Figure 5-9 (output should return to within 10mV of original value in less than 50 microseconds).

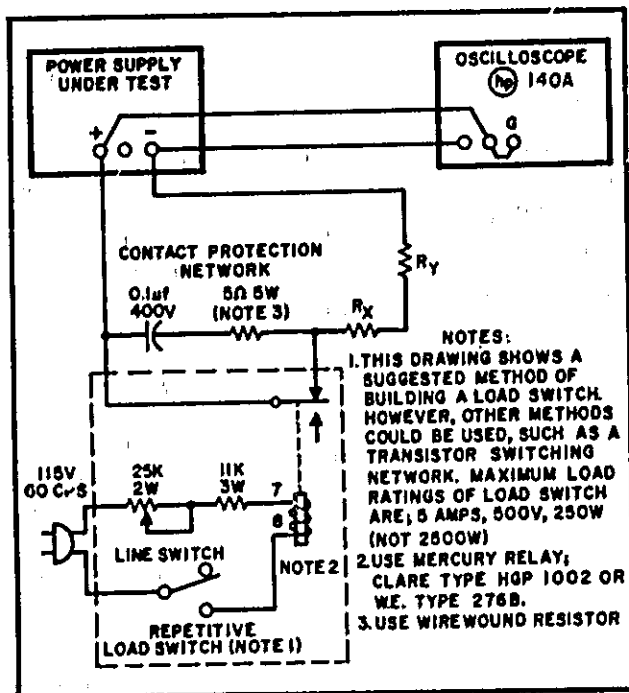

Figure 5-8. Transient Recovery Time, Test Setup

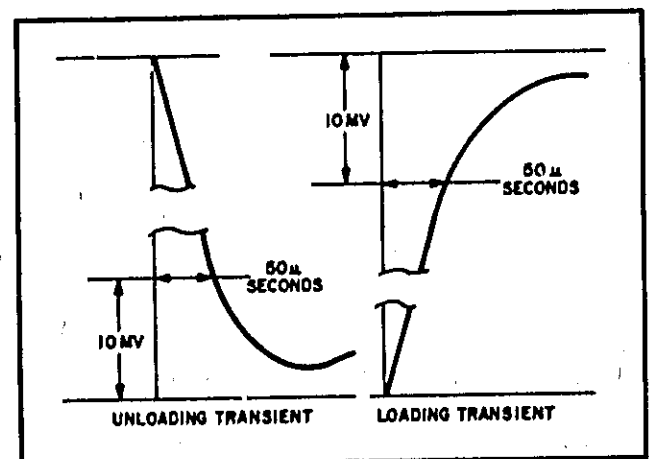

Figure 5-9. Transient Recovery Time, Waveforms

5-38 OUTPUT IMPEDANCE

5-39 To check the output impedance, proceed as follows:

- Connect test setup shown in Figure 5-10.
- Set METER switch to highest voltage range.
- Turn on supply and adjust VOLTAGE controls until front panel meter reads 20 Volts.
- Set AMPLITUDE control on oscillator to 10 Volts (E_{in}), and FREQUENCY control to 100Hz.
- Record voltage across output terminals of the power supply (E_o) as indicated on ac voltmeter.
- Calculate the output impedance by the

following formula:

$$Z_{out} = \frac{E_o R}{E_{in} - E_o}$$

E_o = rms voltage across power supply output terminals,

$R = 1000$

$E_{in} = 10$ Volts

g. The output impedance (Z_{out}) should be less than 0.020 ohms.

h. Using formula of Step f, calculate output impedance at frequencies of 50kHz and 500kHz. Values should be less than 0.5 ohm and 3.0 ohms, respectively.

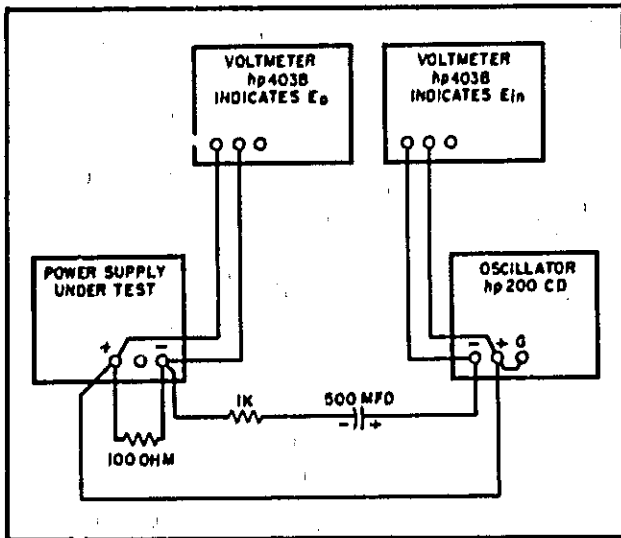

Figure 5-10. Output Impedance, Test Setup

5-40 Temperature Coefficient.

Definition: The change in output voltage per degree Centigrade change in the ambient temperature under conditions of constant input ac line voltage, output voltage setting, and load resistance.

5-41 The temperature coefficient of a power supply is measured by placing the power supply in an oven and varying it over any temperature span within its rating. (Most power supplies are rated for operation from 0°C to 55°C.) The power supply must be allowed to thermally stabilize for a sufficient period of time at each temperature of measurement.

5-42 The temperature coefficient specified is the maximum temperature-dependent output voltage change which will result over any 5°C interval. The differential voltmeter or digital voltmeter used to measure the output voltage change of the

supply should be placed outside the oven and should have a long term stability adequate to insure that its drift will not affect the overall measurement accuracy.

5-43 To check the temperature coefficient, proceed as follows:

a. Connect test setup shown in Figure 5-5.
b. Turn CURRENT controls fully clockwise and adjust front panel VOLTAGE controls until the front panel voltmeter indicates 10Vdc.

c. Insert the power supply into the temperature-controlled oven (differential voltmeter and load resistance remain outside oven). Set the temperature to 30°C and allow 30 minutes warm-up.

d. Record the differential voltmeter indication.

e. Raise the temperature to 40°C and allow 30 minutes warm-up.

f. The differential voltmeter indication should change by less than 90mV from indication recorded in Step d.

5-44 Output Stability.

Definition: The change in output voltage for the first eight hours following a 30 minute warm-up period. During the interval of measurement all parameters, such as load resistance, ambient temperature, and input line voltage are held constant.

5-45 This measurement is made by monitoring the output of the power supply on a differential voltmeter or digital voltmeter over the stated measurement interval; a strip chart recorder can be used to provide a permanent record. A thermometer should be placed near the supply to verify that the ambient temperature remains constant during the period of measurement. The supply should be put in a location immune from stray air currents (open doors or windows, air conditioning vents); if possible, the supply should be placed in an oven which is held at a constant temperature. Care must be taken that the measuring instrument has a stability over the eight hour interval which is at least an order of magnitude better than the stability specification of the power supply being measured. Typically, a supply may drift less over the eight hour measurement interval than during the ½ hour warm-up period.

5-46 Stability measurement can be made while the supply is remotely programmed with a fixed wire-wound resistor, thus avoiding accidental changes in the front panel setting due to mechanical vibration or "knob-twiddling."

5-47 To check the output stability, proceed as follows:

- a. Connect test setup shown in Figure 5-5,
- b. Turn CURRENT controls fully clockwise and adjust VOLTAGE controls for 40Vdc output.
- c. Allow 30 minutes warm-up then record the differential voltmeter indication.
- d. After 3 hours, differential voltmeter should change by less than 45mV from indication recorded in Step c.

5-48 TROUBLESHOOTING

5-49 Before attempting to troubleshoot this instrument, ensure that the fault is with the instrument and not with an associated circuit. The performance test (Paragraph 5-10) enables this to be determined without having to remove the instrument from the cabinet.

5-50 A good understanding of the principles of operation is a helpful aid in troubleshooting, and it is recommended that the reader review Section IV of the manual before attempting to troubleshoot the unit in detail. Once the principles of operation are understood, refer to the overall troubleshooting procedures in Paragraph 5-53 to locate the symptom and probable cause.

5-51 The schematic diagram at the rear of the manual (Figure 7-1) contains normal voltage read-

ings taken at various points within the circuits. These voltages are positioned adjacent to the applicable test points (identified by encircled numbers). Component and test point designations are marked directly on the main printed wiring board.

5-52 If a defective component is located, replace it and re-conduct the performance test. When a component is replaced, refer to the repair and replacements and adjustment and calibration paragraphs in this section.

5-53 OVERALL TROUBLESHOOTING PROCEDURE

5-54 To locate the cause of trouble follow Steps 1, 2, and 3 in sequence.

(1) Check for obvious troubles such as open fuse, defective power cord, input power failure, or defective voltage or current meter. Next remove the top cover (held by four retaining screws) and inspect for open connections, charged components, etc. If the trouble source cannot be detected by visual inspection, proceed with Step 2.

(2) In almost all cases, the trouble can be caused by improper dc bias or reference voltages; thus, it is a good practice to check voltages in Table 5-2, before proceeding with Step 3.

(3) Disconnect the load and examine Table 5-3 to determine your symptom and probable cause.

Table 5-2. Reference Circuit Troubleshooting

STEP	METER COMMON	METER POSITIVE	NORMAL INDICATION	NORMAL RIPPLE (p-p)	IF INDICATION ABNORMAL, TAKE THIS ACTION
1	+S	33	$6.2 \pm 0.3Vdc$.3mV	Check 12.4 Volt bias or VR1 (See next paragraph)
2	31	+S	$6.2 \pm 0.3Vdc$.4mV	Check 12.4 Volt bias or VR2 (See next paragraph)
3	+S	37	$12.4 \pm 1.0Vdc$	2.8 μ V	Check Q8, Q9, CR22, CR23, C10, T1
4	38	41	$7.5 \pm .7Vdc$	1V	Check C12, CR8, CR24, CR25

Table 5-3. Overall Troubleshooting

SYMPTOM	CHECKS AND PROBABLE CAUSES
High output voltage	<ol style="list-style-type: none"> a. Front panel meter defective. b. Series regulator feedback loop defective. Refer to Table 5-4.
Low output voltage	<ol style="list-style-type: none"> a. Fuses blown (Check CR26-CR29 or C14 for short).

Table 5-3. Overall Troubleshooting (Continued)

SYMPTOM	CHECKS AND PROBABLE CAUSES
	b. Front panel meter defective. c. Series regulator feedback loop defective. Refer to Table 5-5.
Will not current limit	a. Q10 open. R81 defective.
High ripple	a. Check operating setup for ground loops. b. If output floating, connect 1 μ f capacitor between output and ground. c. Ensure that supply is not crossing over to current limit mode under loaded conditions.
Poor line regulation	a. Check reference circuit (Paragraph 5-55). b. Check reference circuit adjustment (Paragraph 5-69).
Poor load regulation (constant voltage)	a. Measurement technique. (Paragraph 5-17) b. Check reference circuit (Paragraph 5-55) and adjustment (Paragraph 5-69). c. Ensure that supply is not going into current limit.
Oscillates (constant voltage)	a. Check C5 for open, adjustment of R30 (Paragraph 5-72).
Poor stability (constant voltage)	a. Check ± 6.2 Vdc reference voltages (Paragraph 5-55). b. Noisy programming resistor R10. c. CR1, CR2 leaky. d. Check R1, R12, R13, for noise or drift. e. Stage Q1 defective.

5-55 To check the zener diodes in the reference circuit, proceed as follows:

- a. Connect differential voltmeter across zener diode.
- b. Connect appropriate load resistor, given in Figure 5-4, across (+) and (-) output terminals.
- c. Turn VOLTAGE control fully clockwise.
- d. Set METER switch to highest current range and turn on supply.
- e. Adjust CURRENT controls until panel meter reads exactly the maximum rated output current.
- f. Read and record voltage indicated on differential voltmeter.
- g. Short out load resistor by closing S1.
- h. If reading on differential voltmeter differs by more than 1.07mV for 6204B and 6205B or .946mV for 6206B from the reading in Step f, replace zener diode.

5-56 Series Regulating Feedback Loop. When troubleshooting the series regulating loop, it is useful to open the loop since measurements made anywhere within a closed loop may appear abnormal. With a loop closed, it is very difficult to separate cause from effect. As described in Tables 5-4 and 5-5, the conduction or cutoff capability of each stage is checked by shorting or opening a previous stage, as follows:

1. Shorting the emitter to collector of a transistor simulates saturation, or the full ON condition.
2. Shorting the emitter to base of a transistor cuts it off, and simulates an open circuit between emitter and collector.

5-57 Although a logical first choice might be to break the loop somewhere near its mid-point, and then perform successive subdividing test, it is

more useful to trace the loop from the series regulator backwards a stage at a time, since loop

failures occur more often at the higher power levels,

Table 5-4. High Output Voltage Troubleshooting

STEP	ACTION	RESPONSE	PROBABLE CAUSE
1	Check turn off of series regulator by shorting Q4 emitter to collector	a. Output voltage remains high b. Output voltage decreases	a. Series regulator Q7 (or Q6) shorted b. Remove short and proceed to Step 2
2	Check turn on of driver by disconnecting emitter of Q5	a. Output voltage remains high b. Output voltage decreases	a. Q4 open b. Reconnect lead and proceed to Step 3
3	Check turn off of Q5 by disconnecting collector of Q3	a. Output voltage remains high b. Output voltage decreases	a. Q5 shorted b. Reconnect lead and proceed to Step 4
4	Check turn off of Q3 by disconnecting collector of Q1A	a. Output voltage remains high b. Output voltage decreases	a. Q3 shorted b. Check Q1A for short, Q1B for open. Check for open strap between A6 and A8. Check R10 for open

Table 5-5. Low Output Voltage Troubleshooting

STEP	ACTION	RESPONSE	PROBABLE CAUSE
1	Check turn on of Q7 (and Q6, if included) by opening the emitter of Q4	a. Output voltage remains low b. Output voltage increases	a. Q7 (or Q6) open b. Reconnect lead and proceed to Step 2
2	Eliminate the current limit circuit as a source of trouble by disconnecting the anode of CR16	a. Output voltage increases b. Output voltage remains low	a. Q10 shorted, R81 defective b. Reconnect lead and proceed to Step 3
3	Check turn off of Q4 by shorting Q5 emitter to collector	a. Output voltage remains low b. Output voltage increases	a. Q4 shorted b. Remove the short and proceed to Step 4
4	Check turn on of Q5 by shorting Q3 emitter to collector	a. Output voltage remains low b. Output voltage increases	a. Q5 open b. Remove short and proceed to Step 5

Table 5-5. Low Output Voltage Troubleshooting (Continued)

STEP	ACTION	RESPONSE	PROBABLE CAUSE
5	Check turn on of Q3 by shorting Q1A emitter to collector	a. Output voltage remains low b. Output voltage increases	a. Q3 open b. Check Q1A for open, Q1B for short. Check R10 for short or open strap between A7 and A5

5-58 REPAIR AND REPLACEMENT

5-59 Before servicing a printed wiring board, refer to Figure 5-11, Section VI of this manual contains a tabular list of the instruments replaceable parts. Before replacing a semiconductor device, refer to Table 5-6 which lists the special charac-

teristics of selected semiconductors. If the device to be replaced is not listed in Table 5-6, the standard manufacturers part number listed in Section VI is applicable. After replacing a semiconductor, refer to Table 5-7 for checks and adjustments that may be necessary.

Table 5-6. Selected Semiconductor Characteristics

REFERENCE DESIGNATOR	CHARACTERISTICS	STOCK NO.	SUGGESTED REPLACEMENT
Q1	Matched differential amplifier. NPN Si, planar 70 (min.) h_{FE} $I_C = 1mA$, $V_{CE} = 5V$, $I_{CO} = 0.01\mu A$ @ $V_{cho} = 5V$.	1854-0229	2N2917 G.E.
Q7	NPN Power $h_{FE} = 35$ (min.) @ $I_C = 4A$; $V_{CE} = 4V$.	1854-0225	2N3055 R.C.A.

Table 5-7. Checks and Adjustments After Replacement of Semiconductor Devices

REFERENCE	FUNCTION	CHECK	ADJUST
Q1	Constant voltage differential amplifier	Constant voltage (CV) line and load regulation. Zero Volt output.	R6 or R8
Q3, Q4	Error amplifiers	CV load regulation, CV transient response.	R30
Q7 (Q6)	Series regulator	CV load regulation.	
Q8, Q9	Reference regulator	Reference circuit line regulation.	VR1, VR2, CR20
CR1, CR2	Limiting diodes	CV load regulation.	
CR8	Forward bias regulator	Voltage across diode 2.0 to 2.4 Volts.	

Table 5-7. Checks and Adjustments After Replacement of Semiconductor Devices (Continued)

REFERENCE	FUNCTION	CHECK	ADJUST
Q10, CR16 (CR21)		Current limit adjustment.	R81
CR22 thru CR29	Rectifier diodes	Voltage across appropriate filter capacitor.	
VR1	Positive reference voltage	+6.2V line and load regulation.	R46, VR1
VR2	Negative reference voltage	-6.2V line and load regulation.	R46, VR2

5-60 ADJUSTMENT AND CALIBRATION

5-61 Adjustment and calibration may be required after performance testing, troubleshooting, or repair and replacement. Perform only those adjustments that affect the operation of the faulty circuit and no others.

5-62 METER ZERO

5-63 Proceed as follows to zero meter:

- Turn off instrument (after it has reached normal operating temperature) and allow 30 seconds for all capacitors to discharge.
- Insert sharp pointed object (pen point or awl) into the small hole at top of round black plastic disc located directly below meter face.
- Rotate plastic disc clockwise (cw) until meter reads zero, then rotate ccw slightly in order to free adjustment screw from meter suspension. If pointer moves, repeat Steps b and c.

5-64 AMMETER TRACKING

5-65 To calibrate the ammeter, proceed as follows:

- Connect test setup as shown on Figure 5-4.
- Set RANGE switch to low voltage mode and METER switch to lowest current range.
- Turn on supply and adjust VOLTAGE controls so that differential voltmeter indicates exactly 0.3Vdc.
- Front panel meter should read 0.06 Amps for Model 6204B and 6205B supplies, or 0.1 Amps for Model 6206B supply. If it does not, adjust R72.

5-66 CONSTANT VOLTAGE PROGRAMMING CURRENT

5-67 Programming Accuracy. To calibrate the programming current, proceed as follows:

- Connect an 8K, 0.1% resistor (18K resistor for Model 6206B supplies) between terminals -S and A6 on rear barrier strip.
- Disconnect jumper between A7 and A8 (leaving A6 and A7 jumpered).
- Connect decade resistance box in place of R13.
- Connect differential voltmeter between +S and -S terminals on rear barrier strip.
- Set RANGE switch to high voltage mode, METER switch to high voltage range, and turn on supply.
- Adjust decade resistance box so that differential voltmeter reads $40 \pm 0.4\text{Vdc}$ for Models 6204B and 6205B or $60 \pm 0.6\text{Vdc}$ for Model 6206B supplies.
- Replace decade resistance with resistor of appropriate value in R13 position.

5-68 Zero Output Voltage. To calibrate the zero Volt programming accuracy, proceed as follows:

- Connect differential voltmeter between +S and -S terminals.
- Short out voltage controls by connecting jumper between terminals A6 and -S.
- Turn on supply and observe reading on differential voltmeter.
- If it is more positive than 0 Volts, shunt resistor R6 with a decade resistance box.
- Adjust decade resistance until differential voltmeter reads zero, then shunt R6 with resistance value equal to that of the decade resistance.
- If reading of Step c was more negative than 0 Volts, shunt resistor R8 with the decade resistance box.
- Adjust decade resistance until differential voltmeter reads zero then shunt R8 with a resistance value equal to that of the decade box.

Excessive heat or pressure can lift the copper strip from the board. Avoid damage by using a low power soldering iron (50 watts maximum) and following these instructions. Copper that lifts off the board should be cemented in place with a quick drying acetate base cement having good electrical insulating properties.

A break in the copper should be repaired by soldering a short length of tinned copper wire across the break.

Use only high quality rosin core solder when repairing etched circuit boards. NEVER USE PASTE FLUX. After soldering, clean off any excess flux and coat the repaired area with a high quality electrical varnish or lacquer.

When replacing components with multiple mounting pins such as tube sockets, electrolytic capacitors, and potentiometers, it will be necessary to lift each pin slightly, working around the components several times until it is free.

WARNING: If the specific instructions outlined in the steps below, regarding etched circuit boards without eyelets are not followed, extensive damage to the etched circuit board will result.

1. Apply heat sparingly to lead of component to be replaced. If lead of component passes through an eyelet in the circuit board, apply heat on component side of board. If lead of component does not pass through an eyelet, apply heat to conductor side of board.

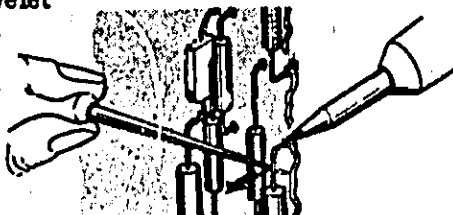

2. Reheat solder in vacant eyelet and quickly insert a small awl to clean inside of hole. If hole does not have an eyelet, insert awl or a #57 drill from conductor side of board.

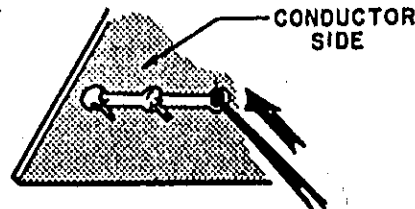

3. Bend clean tinned lead on new part and carefully insert through eyelets or holes in board.

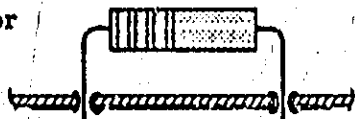

4. Hold part against board (avoid overheating) and solder leads. Apply heat to component leads on correct side of board as explained in step 1.

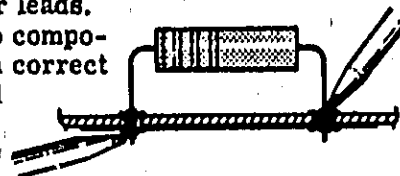

In the event that either the circuit board has been damaged or the conventional method is impractical, use method shown below. This is especially applicable for circuit boards without eyelets.

1. Clip lead as shown below.

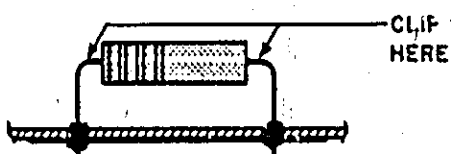

2. Bend protruding leads upward. Bend lead of new component around protruding lead. Apply solder using a pair of long nose pliers as a heat sink.

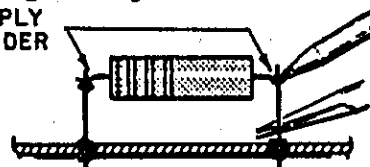

This procedure is used in the field only as an alternate means of repair. It is not used within the factory.

Figure 5-11. Servicing Printed Wiring Boards

5-69 REFERENCE CIRCUIT ADJUSTMENTS

5-70 Line Regulation. To adjust the line regulation capabilities of the instrument proceed as follows:

- a. Connect the differential voltmeter between +S (positive) and 31 (common).
- b. Connect variable voltage transformer between supply and input power source.
- c. Adjust line to 105Vac.
- d. Connect decade resistance in place of R46.
- e. Set range switch to high voltage mode and turn on supply.
- f. Adjust decade resistance so that voltage indicated by differential voltmeter does not change more than 1.08 millivolts for 6204B and 6205B or .946mV for 6206B as input line voltage is varied from 105 to 125Vac.
- g. Replace decade resistance with appropriate value resistor in R46 position.

5-71 CONSTANT VOLTAGE TRANSIENT RECOVERY TIME

5-72 To adjust the transient response, proceed

as follows:

- a. Connect test setup as shown in Figure 5-8.
- b. Repeat Steps a through f as outlined in Paragraph 5-37.
- c. Adjust R30 so that the transient response is as shown in Figure 5-9.

5-73 CURRENT LIMIT ADJUSTMENT

5-74 To adjust the current limit so that the supply can be used to furnish maximum rated output current, proceed as follows:

- a. Connect test setup shown in Figure 5-5.
- b. Short out load resistor (R_L).
- c. Set RANGE switch to low voltage (high current) mode.
- d. Turn on supply and rotate VOLTAGE controls fully clockwise (maximum).
- e. Adjust R81 until differential voltmeter indicates 3.5Vdc for Models 6204B and 6205B supplies or 3.6Vdc for Model 6206B supply.

SECTION VI REPLACEABLE PARTS

6-1 INTRODUCTION

6-2 This section contains information for ordering replacement parts. Table 6-4 lists parts in alpha-numeric order by reference designators and provides the following information:

- a. Reference Designators. Refer to Table 6-1.
- b. Description. Refer to Table 6-2 for abbreviations.
- c. Total Quantity (TQ). Given only the first time the part number is listed except in instruments containing many sub-modular assemblies, in which case the TQ appears the first time the part number is listed in each assembly.
- d. Manufacturer's Part Number or Type.
- e. Manufacturer's Federal Supply Code Number. Refer to Table 6-3 for manufacturer's name and address.
- f. Hewlett-Packard Part Number.
- g. Recommended Spare Parts Quantity (RS) for complete maintenance of one instrument during one year of isolated service.
- h. Parts not identified by a reference designator are listed at the end of Table 6-4 under Mechanical and/or Miscellaneous. The former consists of parts belonging to and grouped by individual assemblies; the latter consists of all parts not immediately associated with an assembly.

6-3 ORDERING INFORMATION

6-4 To order a replacement part, address order or inquiry to your local Hewlett-Packard sales office (see lists at rear of this manual for addresses). Specify the following information for each part: Model, complete serial number, and any Option or special modification (J) numbers of the instrument; Hewlett-Packard part number; circuit reference designator; and description. To order a part not listed in Table 6-4, give a complete description of the part, its function, and its location.

Table 6-1. Reference Designators

A = assembly	E = miscellaneous
B = blower (fan)	electronic part
C = capacitor	F = fuse
CB = circuit breaker	J = jack, jumper
CR = diode	K = relay
DS = device, signaling (lamp)	L = inductor
	M = meter

Table 6-1. Reference Designators (Continued)

P = plug	V = vacuum tube, neon bulb, photocell, etc.
Q = transistor	
R = resistor	VR = zener diode
S = switch	X = socket
T = transformer	Z = integrated circuit or network
TB = terminal block	
TS = thermal switch	

Table 6-2. Description Abbreviations

A = ampere	mfr = manufacturer
ac = alternating current	mod. = modular or modified
assy. = assembly	mtg = mounting
bd = board	n = nano = 10^{-9}
bkt = bracket	NC = normally closed
°C = degree Centigrade	NO = normally open
cd = card	NP = nickel-plated
coef = coefficient	Ω = ohm
comp = composition	obd = order by description
CRT = cathode-ray tube	OD = outside diameter
CT = center-tapped	p = pico = 10^{-12}
dc = direct current	P.C. = printed circuit
DPDT = double pole, double throw	pot. = potentiometer
DPST = double pole, single throw	p-p = peak-to-peak
elect = electrolytic	ppm = parts per million
encap = encapsulated	pvr = peak reverse voltage
F = farad	rect = rectifier
°F = degree Fahrenheit	rms = root mean square
fxd = fixed	Si = silicon
Ge = germanium	SPDT = single pole, double throw
H = Henry	SPST = single pole, single throw
Hz = Hertz	SS = small signal
IC = integrated circuit	T = slow-blow
ID = inside diameter	tan. = tantalum
incnd = incandescent	Ti = titanium
k = kilo = 10^3	v = volt
m = milli = 10^{-3}	var = variable
M = mega = 10^6	ww = wirewound
μ = micro = 10^{-6}	W = Watt
met. = metal	

Table 6-3. Code List of Manufacturers

CODE NO.	MANUFACTURER	ADDRESS
00629	EBY Sales Co., Inc.	Jamaica, N. Y.
00656	Aerovox Corp.	New Bedford, Mass.
00853	Sangamo Electric Co.	
	S. Carolina Div.	Pickens, S. C.
01121	Allen Bradley Co.	Milwaukee, Wis.
01271	Litton Industries, Inc.	
		Beverly Hills, Calif.
01281	TRW Semiconductors, Inc.	
		Lawndale, Calif.
01295	Texas Instruments, Inc.	
	Semiconductor-Components Div.	
		Dallas, Texas
01686	RCL Electronics, Inc.	Manchester, N. H.
01930	Amerock Corp.	Rockford, Ill.
02107	Sparta Mfg. Co.	Dover, Ohio
02114	Ferrocube Corp.	Saugerties, N. Y.
02606	Fenwal Laboratories	Morton Grove, Ill.
02660	Amphenol Corp.	Broadview, Ill.
02735	Radio Corp. of America, Solid State and Receiving Tube Div.	Somerville, N. J.
03508	G. E. Semiconductor Products Dept.	
		Syracuse, N. Y.
03797	Eldema Corp.	Compton, Calif.
03877	Transitron Electronic Corp.	
		Wakefield, Mass.
03888	Pyrofilm Resistor Co., Inc.	
		Cedar Knolls, N. J.
04009	Arrow, Hart and Hegeman Electric Co.	
		Hartford, Conn.
04072	ADC Electronics, Inc.	Harbor City, Calif.
04213	Caddell & Burns Mfg. Co., Inc.	
		Mineola, N. Y.
04404	*Hewlett-Packard Co. Palo Alto Div.	
		Palo Alto, Calif.
04713	Motorola Semiconductor Prod. Inc.	
		Phoenix, Arizona
05277	Westinghouse Electric Corp.	
	Semiconductor Dept.	Youngwood, Pa.
05347	Ultronix, Inc.	Grand Junction, Colo.
05820	Wakefield Engr. Inc.	Wakefield, Mass.
06001	General Elect. Co. Electronic Capacitor & Battery Dept.	Irmo, S. C.
06004	Bassik Div. Stewart-Warner Corp.	
		Bridgeport, Conn.
06486	IRC Div. of TRW Inc.	
	Semiconductor Plant	Lynn, Mass.
06540	Amatom Electronic Hardware Co., Inc.	
		New Rochelle, N. Y.
06555	Beede Electrical Instrument Co.	
		Penacook, N. H.
06666	General Devices Co., Inc.	
		Indianapolis, Ind.
06751	Semcor Div. Components, Inc.	
		Phoenix, Arizona
06776	Robinson Nugent, Inc.	New Albany, Ind.
06812	Torrington Mfg. Co., West Div.	
		Van Nuys, Calif.
07137	Transistor Electronics Corp.	
		Minneapolis, Minn.

CODE NO.	MANUFACTURER	ADDRESS
07138	Westinghouse Electric Corp.	
	Electronic Tube Div.	Elmira, N. Y.
07263	Fairchild Camera and Instrument Corp. Semiconductor Div.	
		Mountain View, Calif.
07387	Birtcher Corp., The	Los Angeles, Calif.
07397	Sylvania Electric Prod. Inc.	
	Sylvania Electronic Systems Western Div.	Mountain View, Calif.
07716	IRC Div. of TRW Inc.	Burlington Plant Burlington, Iowa
07910	Continental Device Corp.	
		Hawthorne, Calif.
07933	Raytheon Co. Components Div.	
	Semiconductor Operation	
		Mountain View, Calif.
08484	Breeze Corporations, Inc.	Union, N. J.
08530	Reliance Mica Corp.	Brooklyn, N. Y.
08717	Sloan Company, The	Sun Valley, Calif.
08730	Vemaline Products Co., Inc.	Wyckoff, N. J.
08806	General Elect. Co. Mini- ature Lamp Dept.	
		Cleveland, Ohio
08863	Nylomatic Corp.	Norrisville, Pa.
08919	RCH Supply Co.	Vernon, Calif.
09021	Airco Speer Electronic Components	
		Bradford, Pa.
09182	*Hewlett-Packard Co. New Jersey Div.	
		Berkeley Heights, N. J.
09213	General Elect. Co. Semiconductor Prod. Dept.	
		Buffalo, N. Y.
09214	General Elect. Co. Semiconductor Prod. Dept.	
		Auburn, N. Y.
09353	C & K Components Inc.	Newton, Mass.
09922	Burdry Corp.	Norwalk, Conn.
11115	Wagner Electric Corp.	
	Tung-Sol Div.	Bloomfield, N. J.
11236	CTS of Berne, Inc.	Berne, Ind.
11237	Chicago Telephone of Cal. Inc.	
		So. Pasadena, Calif.
11502	IRC Div. of TRW Inc.	Boone Plant Boone, N. C.
11711	General Instrument Corp Rectifier Div.	
		Newark, N. J.
12136	Philadelphia Handle Co. Inc.	
		Camden, N. J.
12615	U. S. Terminals, Inc.	Cincinnati, Ohio
12617	Hamlin Inc.	Lake Mills, Wisconsin
12697	Clarostat Mfg. Co. Inc.	Dover, N. H.
13103	Thermalloy Cp.	Dallas, Texas
14493	*Hewlett-Packard Co. Loveland Div.	
		Loveland, Colo.
14655	Cornell-Dubiller Electronics Div. Federal Pacific Electric Co.	
		Newark, N. J.
14936	General Instrument Corp. Semicon- ductor Prod. Group	Hicksville, N. Y.
15801	Fenwal Elect.	Framingham, Mass.
16299	Corning Glass Works, Electronic Components Div.	
		Raleigh, N. C.

*Use Code 28480 assigned to Hewlett-Packard Co., Palo Alto, California

Table 6-3. Code List of Manufacturers (Continued)

CODE NO.	MANUFACTURER	ADDRESS
16758	Delco Radio Div. of General Motors Corp.	Kokomo, Ind.
17545	Atlantic Semiconductors, Inc.	Asbury Park, N. J.
17803	Fairchild Camera and Instrument Corp Semiconductor Div. Transducer Plant	Mountain View, Calif.
17870	Daven Div. Thomas A. Edison Industries McGraw-Edison Co.	Orange, N. J.
18324	Signetics Corp.	Sunnyvale, Calif.
19315	Bendix Corp. The Navigation and Control Div.	Teterboro, N. J.
19701	Electra/Midland Corp.	Mineral Wells, Texas
21520	Fansteel Metallurgical Corp.	No. Chicago, Ill.
22229	Union Carbide Corp. Electronics Div.	Mountain View, Calif.
22753	UID Electronics Corp.	Hollywood, Fla.
23936	Pamator, Inc.	Pampa, Texas
24446	General Electric Co.	Schenectady, N. Y.
24455	General Electric Co. Lamp Div. of Con- sumer Prod. Group	Nela Park, Cleveland, Ohio
24655	General Radio Co.	West Concord, Mass.
24681	LTV ElectroSystems Inc Memcor/Com- ponents Operations	Huntington, Ind.
26982	Dynacool Mfg. Co. Inc.	Saugerties, N. Y.
27014	National Semiconductor Corp.	Santa Clara, Calif.
28480	Hewlett-Packard Co.	Palo Alto, Calif.
28520	Heyman Mfg. Co.	Kenilworth, N. J.
28875	IMC Magnetics Corp.	
	New Hampshire Div.	Rochester, N. H.
31514	SAE Advance Packaging, Inc.	Santa Ana, Calif.
31827	Budwig Mfg. Co.	Ramona, Calif.
33173	G. E. Co. Tube Dept.	Owensboro, Ky.
35434	Lectrohm, Inc.	Chicago, Ill.
37942	P. R. Mallory & Co. Inc.	Indianapolis, Ind.
42190	Muter Co.	Chicago, Ill.
43334	New Departure-Hyatt Bearings Div.	
	General Motors Corp.	Sandusky, Ohio
44655	Ohmite Manufacturing Co.	Skokie, Ill.
46384	Penn Engr. and Mfg. Corp.	Doylestown, Pa.
47904	Polaroid Corp.	Cambridge, Mass.
49956	Raytheon Co.	Lexington, Mass.
55026	Simpson Electric Co. Div. of American Gage and Machine Co.	Chicago, Ill.
56289	Sprague Electric Co.	North Adams, Mass.
58474	Superior Electric Co.	Bristol, Conn.
58849	Syntron Div. of FMC Corp.	
		Homer City, Pa.
59730	Thomas and Betts Co.	Philadelphia, Pa.
61637	Union Carbide Corp.	New York, N. Y.
63743	Ward Leonard Electric Co.	Mt. Vernon, N. Y.

CODE NO.	MANUFACTURER	ADDRESS
70563	Amperlite Co. Inc.	Union City, N. J.
70901	Beemer Engrg. Co.	Fort Washington, Pa.
70903	Belden Corp.	Chicago, Ill.
71218	Bud Radio, Inc.	Willoughby, Ohio
71279	Cambridge Thermionic Corp.	Cambridge, Mass.
71400	Bussmann Mfg. Div. of McGraw & Edison Co.	St. Louis, Mo.
71450	CTS Corp.	Elkhart, Ind.
71468	I. T. T. Cannon Electric Inc.	Los Angeles, Calif.
71590	Globe-Union Inc.	
	Centralab Div.	Milwaukee, Wis.
71700	General Cable Corp. Cornish Wire Co. Div.	Williamstown, Mass.
71707	Coto Col! Co. Inc.	Providence, R. I.
71744	Chicago Miniature Lamp Works	Chicago, Ill.
71785	Cinch Mfg. Co. and Howard B. Jones Div.	Chicago, Ill.
71984	Dow Corning Corp.	Midland, Mich.
72136	Electro Motive Mfg. Co. Inc.	Willimantic, Conn.
72619	Dialight Corp.	Brooklyn, N. Y.
72699	General Instrument Corp.	Newark, N. J.
72765	Drake Mfg. Co.	Harwood Heights, Ill.
72962	Elastic Stop Nut Div. of Amerace Esna Corp.	Union, N. J.
72982	Erie Technological Products Inc.	Erie, Pa.
73096	Hart Mfg. Co.	Hartford, Conn.
73138	Beckman Instruments Inc.	
	Hellipot Div.	Fullerton, Calif.
73168	Fenwal, Inc.	Ashland, Mass.
73293	Hughes Aircraft Co. Electron Dynamics Div.	Torrance, Calif.
73445	AmpereX Electronic Corp.	Hicksville, N. Y.
73506	Bradley Semiconductor Corp.	New Haven, Conn.
73559	Carling Electric, Inc.	Hartford, Conn.
73734	Federal Screw Products, Inc.	Chicago, Ill.
74193	Heinemann Electric Co.	Trenton, N. J.
74545	Hubbell Harvey Inc.	Bridgeport, Conn.
74868	Amphenol Corp. Amphenol RF Div.	Danbury, Conn.
74970	E. F. Johnson Co.	Waseca, Minn.
75042	IRC Div. of TRW, Inc.	Philadelphia, Pa.
75183	*Howard B. Jones Div. of Cinch Mfg. Corp.	New York, N. Y.
75376	Kurz and Kasch, Inc.	Dayton, Ohio
75382	Kilka Electric Corp.	Mt. Vernon, N. Y.
75915	Littlefuse, Inc.	Des Plaines, Ill.
76381	Minnesota Mining and Mfg. Co.	St. Paul, Minn.
76385	Minor Rubber Co. Inc.	Bloomfield, N. J.
76487	James Millen Mfg. Co. Inc.	Malden, Mass.
76493	J. W. Miller Co.	Compton, Calif.

*Use Code 71785 assigned to Cinch Mfg. Co., Chicago, Ill.

Table 6-3. Code List of Manufacturers (Continued)

CODE NO.	MANUFACTURER	ADDRESS
76530	Cinch	City of Industry, Calif.
76854	Oak Mfg. Co. Div. of Oak	Crystal Lake, Ill.
77068	Bendix Corp., Electrodynamics Div.	No. Hollywood, Calif.
77122	Palnut Co.	Mountainside, N. J.
77147	Patton-MacGuyer Co.	Providence, R. I.
77221	Phaotron Instrument and Electronic Co.	South Pasadena, Calif.
77252	Philadelphia Steel and Wire Corp.	Philadelphia, Pa.
77342	American Machine and Foundry Co.	Princeton, Ind.
77630	Potter and Brumfield Div. TRW Electronic Components Div.	Camden, N. J.
77764	Resistance Products Co.	Harrisburg, Pa.
78189	Illinois Tool Works Inc. Shakeproof Div.	Elgin, Ill.
78452	Everlock Chicago, Inc.	Chicago, Ill.
78488	Stackpole Carbon Co.	St. Marys, Pa.
78526	Stanwyck Winding Div. Electric Mfg. Co. Inc.	Newburgh, N. Y.
78553	Tinnerman Products, Inc.	Cleveland, Ohio
78584	Stewart Stamping Corp.	Yonkers, N. Y.
79136	Waldes Kohinor, Inc.	L. I. C., N. Y.
79307	Whitehead Metals Inc.	New York, N. Y.
79727	Continental-Wirt Electronics Corp.	Philadelphia, Pa.
79963	Zierick Mfg. Co.	Mt. Kisco, N. Y.
80031	Mexco Div. of Sessions Clock Co.	Morristown, N. J.
80294	Bourns, Inc.	Riverside, Calif.
81042	Howard Industries Div. of Msl Ind. Inc.	Racine, Wisc.
81073	Grayhill, Inc.	La Grange, Ill.
81483	International Rectifier Corp.	El Segundo, Calif.
81751	Columbus Electronics Corp.	Yonkers, N. Y.
82099	Goodyear Sundries & Mechanical Co. Inc.	New York, N. Y.
82142	Airco Spier Electronic Components	Du Bois, Pa.
82219	Sylvania Electric Products Inc. Electronic Tube Div. Receiving Tube Operations	Emporium, Pa.
82389	Switchcraft, Inc.	Chicago, Ill.
82647	Metals and Controls Inc. Control Products Group	Attleboro, Mass.
82866	Research Products Corp.	Madison, Wis.
82877	Rotron Inc.	Woodstock, N. Y.
82893	Vector Electronic Co.	Glendale, Calif.
83058	Carr Fastener Co.	Cambridge, Mass.
83186	Victory Engineering Corp.	Springfield, N. J.
83298	Bendix Corp. Electric Power Div.	Eatontown, N. J.
83330	Herman H. Smith, Inc.	Brooklyn, N. Y.
83385	Central Screw Co.	Chicago, Ill.
83501	Gavitt Wire and Cable Div. of Amerace Esna Corp.	Brookfield, Mass.

CODE NO.	MANUFACTURER	ADDRESS
83508	Grant Pulley and Hardware Co.	West Nyack, N. Y.
83594	Burroughs Corp. Electronic Components Div.	Plainfield, N. J.
83835	U. S. Radium Corp.	Morristown, N. J.
83877	Yardeny Laboratories, Inc.	New York, N. Y.
84171	Arco Electronics, Inc.	Great Neck, N. Y.
84411	TRW Capacitor Div.	Ogallala, Neb.
86684	RCA Corp. Electronic Components	Harrison, N. J.
86838	Rummel Fibre Co.	Newark, N. J.
87034	Marco & Oak Industries a Div. of Oak Electro/netics Corp.	Anaheim, Calif.
87216	Philco Corp. Lansdale Div.	Lansdale, Pa.
87525	Stockwell Rubber Co. Inc.	Philadelphia, Pa.
87929	Tower-Olschan Corp.	Bridgeport, Conn.
88140	Cutler-Hammer Inc. Power Distribution and Control Div. Lincoln Plant	Lincoln, Ill.
88245	Litton Precision Products Inc, USECO Div. Litton Industries	Van Nuys, Calif.
90634	Gulton Industries Inc.	Metuchen, N. J.
90763	United-Car Inc.	Chicago, Ill.
91345	Miller Dial and Nameplate Co.	El Monte, Calif.
91418	Radio Materials Co.	Chicago, Ill.
91506	Augat, Inc.	Attleboro, Mass.
91637	Dale Electronics, Inc.	Columbus, Neb.
91662	Elco Corp.	Willow Grove, Pa.
91929	Honeywell Inc. Div. Micro Switch	Freeport, Ill.
92825	Whitso, Inc.	Schiller Pk., Ill.
93332	Sylvania Electric Prod. Inc. Semiconductor Prod. Div.	Woburn, Mass.
93410	Essex Wire Corp. Stemco Controls Div.	Mansfield, Ohio
94144	Raytheon Co. Components Div. Ind. Components Oper.	Quincy, Mass.
94154	Wagner Electric Corp. Tung-Sol Div.	Livingston, N. J.
94222	Southco Inc.	Lester, Pa.
95263	Leecraft Mfg. Co. Inc.	L. I. C., N. Y.
95354	Methode Mfg. Co.	Rolling Meadows, Ill.
95712	Bendix Corp. Microwave Devices Div.	Franklin, Ind.
95987	Weckesser Co. Inc.	Chicago, Ill.
96791	Amphenol Corp. Amphenol Controls Div.	Janesville, Wis.
97464	Industrial Retaining Ring Co.	Irvington, N. J.
97702	IMC Magnetics Corp. Eastern Div.	Westbury, N. Y.
98291	Sealectro Corp.	Mamaroneck, N. Y.
98410	ETC Inc.	Cleveland, Ohio
98978	International Electronic Research Corp.	Burbank, Calif.
99934	Renbrandt, Inc.	Boston, Mass.

Table 6-4. Replaceable Parts

REF. DESIG.	DESCRIPTION	TQ	MFR. PART NO.	MFR. CODE	Ⓢ PART NO.	RS
C1	fxd, elect 10 μ f 100Vdc	1	30D106G100DD4	56289	0180-0091	1
C2-4, 6-8, 11, 15, 17-19	NOT ASSIGNED	-	-	-	-	-
C5	fxd, film .0022 μ f 200Vdc	1	192P22292	56289	0160-0154	1
C9	fxd, elect 4.7 μ f 35Vdc	1	150D475X9035B2	56289	0180-0100	1
C10, 12	fxd, elect 100 μ f 50Vdc	2		09182	0180-1852	1
C13, 14	fxd, elect 400 μ f 100Vdc	3		09182	0180-1887	1
C16	fxd, ceramic .05 μ f 500Vdc	1	33C17A	56289	0150-0052	1
C20	fxd, elect 400 μ f 100Vdc			09182	0180-1887	
CR1, 2	Rect. Si. 200mA 200prv 250mW	4	1N485B	93332	1901-0033	4
CR3-7, 9, 10, 12-15, 18, 19, 21, 30-33	NOT ASSIGNED	-	-	-	-	-
CR8	Rect. Si. 400mW 10prv	1	1N4830	03508	1901-0460	1
CR11	Rect. Si. 500mA 200prv	11	1N3253	02735	1901-0389	7
CR16	Rect. Si. 200mA 200prv 250mW		1N485B	93332	1901-0033	
CR17	Rect. Si. 500mA 200prv		1N3253	02735	1901-0389	
CR20	Rect. Si. 200mA 200prv 250mW		1N485B	93332	1901-0033	
CR22-29, 34	Rect. Si. 500mA 200prv		1N3253	02735	1901-0389	
DS1	Indicator Light, neon	1	599-124	72765	1450-0048	1
F1	Fuse Cartridge 2A 250V 3Ag	1	312002	75915	2110-0002	5
Q1	SS NPN Diff. Amp	1		09182	1854-0229	1
Q2, 11-16	NOT ASSIGNED	-	-	-	-	-
Q3	SS PNP Si.	2	2N2907A	56289	1853-0099	2
Q4	SS PNP Si.	1		09182	1853-0220	1
Q5	SS NPN Si.	4	2N3391	03508	1854-0071	4
Q6, 7	Power NPN Si.	2		09182	1854-0239	2
Q8	SS PNP Si.		2N2907A	56289	1853-0099	
Q9, 10, 17	SS NPN Si.		2N3391	03508	1854-0071	
R1	fxd, ww 1K Ω \pm 5% 3W 20ppm	1	242E1025	56289	0813-0001	1
R2	fxd, met. film 6.2K Ω \pm 1% 1/8W	1	Type CEA T-O	07716	0698-5087	1
R3, 4	fxd, met. film 20K Ω \pm 1% 1/8W	2	Type CEA T-O	07716	0757-0449	1
R5	fxd, met. film 1.5K Ω \pm 1% 1/8W	2	Type CEA T-O	07716	0757-0427	1
R6	fxd, comp 360K Ω \pm 5% $\frac{1}{2}$ W	1	EB-3645	01121	0686-3645	1
R7, 9, 11, 14-26, 28, 36-40, 48, 50, 59, 62-71, 74-79, 82-84	NOT ASSIGNED	-	-	-	-	-
R8	fxd, comp 560K Ω \pm 5% $\frac{1}{2}$ W	1	EB-5645	01121	0686-5645	1
R10	var. ww DUAL 22K-200 Ω	1		09182	2100-0998	1
R12	fxd, ww 2K Ω \pm 5% 3W 20ppm	1	242E2025	56289	0811-1806	1
R13	fxd, comp Selected \pm 5% $\frac{1}{2}$ W	1	Type EB (obd)	01121		1
R27	fxd, ww .51 Ω \pm 5%	2	Type BWH	07716	0811-0929	1
R29	fxd, met. film 1.5K Ω \pm 1% 1/8W		Type CEA T-O	07716	0757-0427	
R30	var. ww 5K Ω (Modify)	1	Type 110-F4	11236	2100-1824	1
R31	fxd, comp 1K Ω \pm 5% $\frac{1}{2}$ W	2	EB-1025	01121	0686-1025	1

REF. DESIG.	DESCRIPTION	TQ	MFR. PART NO.	MFR. CODE	⊕ PART NO.	RS
R32	fxd, ww .51 Ω \pm 5%		Type BWH	07716	0811-0929	
R33	fxd, comp 1K Ω \pm 5% $\frac{1}{2}$ W		EB-1025	01121	0686-1025	
R34	fxd, comp 150 Ω \pm 5% $\frac{1}{2}$ W	1	EB-1515	01121	0686-1515	1
R35	fxd, comp 3.3K Ω \pm 5% $\frac{1}{2}$ W	1	EB-3325	01121	0686-3325	1
R41	fxd, comp 12K Ω \pm 5% $\frac{1}{2}$ W	1	EB-1235	01121	0686-1235	1
R42	fxd, comp 6.8K Ω \pm 5% $\frac{1}{2}$ W	1	EB-6825	01121	0686-6825	1
R43	fxd, met. film 560 Ω \pm 1% $\frac{1}{2}$ W	1	Type CEB T-O	07716	0698-5146	1
R44	fxd, comp 47K Ω \pm 5% $\frac{1}{2}$ W	1	EB-4735	01121	0686-4735	1
R45	fxd, comp 5.1K Ω \pm 5% $\frac{1}{2}$ W	1	EB-5125	01121	0686-5125	1
R46	fxd, comp 100K Ω \pm 5% $\frac{1}{2}$ W	1	EB-1045	01121	0686-1045	1
R47	fxd, comp 910 Ω \pm 5% $\frac{1}{2}$ W	1	EB-9115	01121	0686-9115	1
R49	fxd, ww 1.5K Ω \pm 5% 10W	1	Type 10XM	63743	0811-1913	1
R51	fxd, comp 20K Ω \pm 5% $\frac{1}{2}$ W	1	EB-2035	01121	0686-2035	1
R52	fxd, met. film 2K Ω \pm 1% 1/8W	1	Type CEA T-O	07716	0757-0283	1
R53	fxd, comp 470 Ω \pm 5% $\frac{1}{2}$ W	1	EB-4715	01121	0686-4715	1
R54, 55	fxd, ww 3 Ω \pm 0.5% 3W	2	Type T-3	01686	0811-1986	1
R56	fxd, met. film 1.62K Ω \pm 1% 1/8W	1	Type CEA T-O	07716	0757-0428	1
R57	fxd, met. film 3.4K Ω \pm 1% 1/8W	1	Type CEA T-O	07716	0698-4440	1
R58	fxd, met. film 190 Ω \pm 1% 1/8W	1	Type CEA T-O	07716	0698-5868	1
R60	fxd, met. film 6.81K Ω \pm 1% $\frac{1}{2}$ W	1	Type CEB T-O	07716	0757-0750	1
R61	fxd, met. film 63K Ω \pm 1% 1/8W	1	Type CEA T-O	07716	0698-5152	1
R72	var. ww 100 Ω (R72 Modify)	1	Type 110-F4	11236	2100-0281	1
R73	fxd, met. film 42.2 Ω \pm 1% 1/8W	1	Type CEA T-O	07716	0757-0316	1
R80	fxd, comp 33K Ω \pm 5% $\frac{1}{2}$ W	1	EB-3335	01121	0686-3335	1
R81	var. ww 1K Ω	1	Type 110-F4	11236	2100-0391	1
R85	fxd, met. film 4.75K Ω \pm 1% 1/8W	1	Type CEA T-O	07716	0757-0437	1
R86	fxd, met. film 8.25K Ω \pm 1% 1/8W	1	Type CEA T-O	07716	0757-0441	1
R87	Thermistor 64 Ω \pm 10%	1	LB16J1	15801	0837-0023	1
S1	Switch SPST On/Off	1	T110-72	73559	3101-1055	1
S2	Rotary Switch Concent. Shafts	1		09182	3100-1913	1
T1	Power Transformer	1		09182	9100-1822	1
VR1	Diode Zener 6.2V \pm 5% 400mW	1	1N821	06486	1902-0761	1
VR2	Diode Zener 6.19V \pm 5% 400mW	1	1N753	04713	1902-0049	1
MISCELLANEOUS						
	Front Panel (Blank)	1		09182	5000-6062	
	Front Panel (Includes Components)	1		09182	5000-6064	
	Right Side Casing	1		09182	5000-6057	
	Left Side Casing	1		09182	5000-6058	
	Cover (Top)	1		09182	5000-6061	
	P. C. Board (Includes Components)	1		09182	06206-60020	
	5 Way Binding Post (Red)	1		09182	1510-0040	1
	5 Way Binding Post (Black)	2	DF21BC	58474	1510-0039	1
	Line Cord Plug PH151 7 $\frac{1}{2}$ '	1	KH-4096	70903	8120-0050	1
	Strain Relief Bushing	1	SR-5P-1	28520	0400-0013	1
	Jumper	7	422-13-11-013	71785	0360-114?	1
	Barrier Strip	1		09182	0360-1234	1
	Guard (Barrier Strip)	1		09182	5020-5540	1
	Rubber Bumper	4	MB50	87575	0403-0088	1
	Rubber Bumper (PCB)	3	4072	87575	0403-0086	1
	Knob $\frac{1}{2}$ Insert Pointer (Black)	1		09182	0370-0107	1

REF. DESIG.	DESCRIPTION	TQ	MFR. PART NO.	MFR. CODE	Ⓢ PART NO.	RS
	Knob 17/64 Insert Pointer (Black)	1		09182	0370-0101	1
	Knob, Bar 1/8 Insert Pointer (Red)	1		09182	0370-0102	1
	Knob 3/16 Insert (Red)	1		09182	0370-0179	1
	Meter Bezel 1/6 Mod.	1		09182	5040-06	1
	Fuse Holder	1	342014	75915	1400-00	1
	Meter, Dual Scale 0-70V 0-1.2A	1		09182	1120-1144	1
	Meter Spring	4		09182	1460-0720	1
	Mica Insulator	2	734	08530	0340-0174	2
	Insulator, Transistor Pin	4		09182	0340-0166	4
	Insulator	4		09182	0340-0168	4
	Carton	1		09182	9211-0848	
	End Caps	2		09182	9220-1218	

APPENDIX A

Option 11, Overvoltage Protection "Crowbar"

DESCRIPTION:

This option is installed in DC Power Supplies, 6200B, 6201B, 6202B, 6203B, 6204B, 6206B, and 6294A, and tested at the factory. It consists of a printed circuit board, screwdriver-type potentiometer, and six wires that are soldered to the main power supply board.

The crowbar monitors the output voltage of the power supply and fires an SCR that shorts the output when it exceeds the preset trip voltage. The trip voltage is determined by the setting of the CROWBAR ADJUST control on the front panel. The trip voltage range is as follows:

Model	6200B	6201B	6202B	6203B	6204B	6205B	6206B 6294A
Trip Voltage Range	2.5-44V	2.5-23V	2.5-44V	2.5-10V	2.5-44V	2.5-44V	2.5-65V

To prevent transients from falsely tripping the crowbar, the trip voltage must be set higher than the power supply output voltage by the following margin: 4% of the output voltage plus 2V. The margin represents the minimum crowbar trip setting for a given output voltage; the trip voltage can always be set higher than this margin.

OPERATION:

1. Turn the CROWBAR ADJUST fully clockwise to set the trip voltage to maximum.
2. Set the power supply VOLTAGE control for the desired crowbar trip voltage. To prevent false crowbar tripping, the trip voltage should exceed the desired output voltage by the following amount: 4% of the output voltage plus 2V.
3. Slowly turn the CROWBAR ADJUST ccw until the crowbar trips, output goes to 0 Volt.
4. The crowbar will remain activated and the output shorted until the supply is turned off. To reset the crowbar, turn the supply off, then on.
5. If the CROWBAR must be completely disabled, remove the lead attached to the CROWBAR ADJUST potentiometer R5.

Table A-1. Replaceable Parts

REF. DESIG.	DESCRIPTION	TQ	MFR. PART NO.	MFR. CODE	Ⓢ PART NO.	RS
C1	fxd, elect. 1 μ f 50Vdc	1	30D105G050BA2	56289	0180-0108	1
C2	fxd, mica 510 μ f 500Vdc	1	RCM15E511J	04062	0140-0047	1
CR1-CR3	Rect. Sl. 200mA 200prv	3	1N485B	93332	1901-0033	3
CR4	SCR 7.4A 100prv	1	C20A	03508	1884-0031	1
Q1,2	SS NPN Sl.	2	2N3417	03508	1854-0087	2
R1	fxd, met. film 10 Ω \pm 1% 1/8W	1	Type CEA T-O	07716	0757-0346	1
R2	fxd, comp 5.1K Ω \pm 5% 2W	1	Type C42S	10299	0698-3644	1
R3	fxd, met. film 1.21K Ω \pm 1% 1/8W	1	Type CEA T-O	07716	0757-0274	1
R4	fxd, met. film 19.1K Ω \pm 1% 1/8W	1	Type CEA T-O	07716	0698-4484	1
R5	var ww 10K Ω \pm 5%	1		09182	2100-1854	1
R6	fxd, ww 1K Ω \pm 5% 3W	1	242E1025	56289	0813-0001	1
R7	fxd, comp 22 Ω \pm 5% $\frac{1}{2}$ W	1	EB-2205	01121	0686-2205	1
R8	fxd, met. film 150 Ω \pm 1% 1/8W	1	Type CEA T-O	07716	0757-0284	1
T1	Transformer, Pulse	1		09182	5080-7122	1
VR1	Diode, Zener 16.2V \pm 5%	1	1N966	04713	1902-0184	1
VR2	Diode, Zener 2.37V \pm 5%	1	1N4370	04713	1902-3002	1
	MISCELLANEOUS					
	Printed Circuit Board (Blank)	1		09182	5020-5750	
	P. C. Board (Includes Components)	1		09182	06206-60021	
	Heat Sink	1		09182	5000-6229	
	Insulator (CR4)	1		09182	0340-0462	1
	Mica Washer	1		09182	2190-0709	1
	Cable Clamp	1	T4-4	79307	1400-0330	1
	Front Panel, Modified (Model 6206B)	1		09182	06206-60003	
	Front Panel, Modified (Model 6294A)	1		09182	06294-60003	

**DC POWER SUPPLY
MODEL 6206B, 6294A**

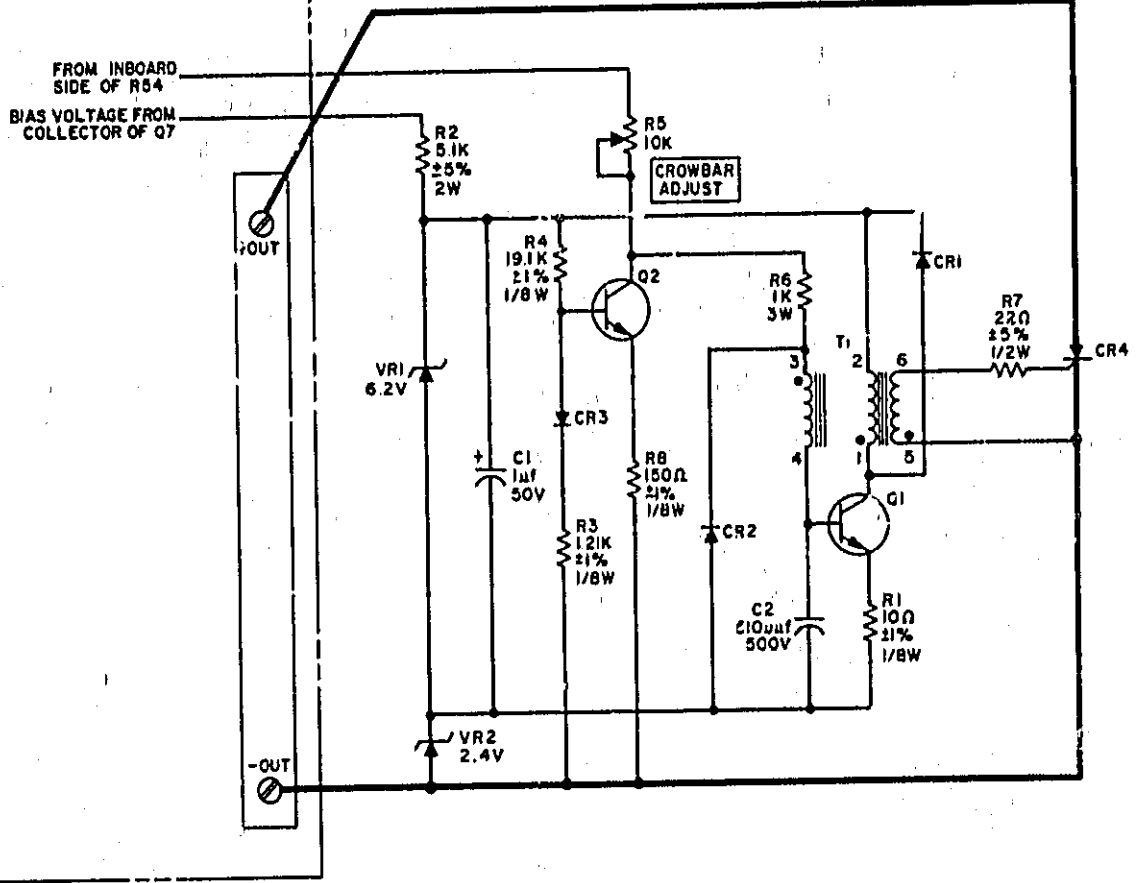

CIRCUIT PATENTS APPLIED FOR. LICENSE TO USE
MUST BE OBTAINED IN WRITING FROM HEWLETT-
PACKARD CO HARRISON DIVISION.

Figure A-1. Model 6206B and Model 6294A Overvoltage Protection "Crowbar"

APPENDIX B MANUAL BACKDATING CHANGES

Manual backdating changes describe changes necessary to adapt this manual to earlier instruments. To adapt the manual to serial numbers prior to 8A2351 inspect the following table for your serial number and then make the appropriate changes. For serial numbers 8M2352 and up check for inclusion of change sheet.

SERIAL		MAKE CHANGES
Prefix	Number	
8A	2277 - 2351	1
8A	2177 - 2276	1, 2
8A	1877 - 2176	1, 2, 3
8A	1677 - 1876	1, 2, 3, 4
6J	0776 - 1676	1, 2, 3, 4, 5

CHANGE 1:

In replaceable parts list, make the following change:

Q4: SS PNP Si., C Part No. 1853-0040.

CHANGE 2:

In replaceable parts list, add:

CR17: Rect. Si. 500mA, 200prv, 1N3253, R. C. A.
 C Part No. 1901-0389.

On schematic, connect CR17 cathode to base of Q6 and anode to +S.

CHANGE 3:

In replaceable parts list, make the following change:

R33: $2.4K_{\Omega} \pm 5\%$ $\frac{1}{2}W$, EB-2425, A. B., C Part No. 0686-2425.

CHANGE 4:

In replaceable parts list, make the following changes:

Add: CR21, Rect. Si. 400mW 10prv, C Part No. 1901-0461.

Delete: Q10, R51.

Change:

R34: $180_{\Omega} \pm 5\%$ $\frac{1}{2}W$, EB-1815, A. B., C Part No. 0686-1815.

R53: $10_{\Omega} \pm 5\%$ $\frac{1}{2}W$, EB-1005, A. B., C Part No. 0686-1005.

R54: $3.08_{\Omega} \pm 0.5\%$ 3W, Type T-3, R. C. L., C
Part No. 0811-1987.

R81: 100_{Ω} variable, Type 110-F4, C. T. S., C
Part No. 2100-0281.

On schematic diagram, make the following changes:

Open R51.

Connect the current limiting circuit as follows:

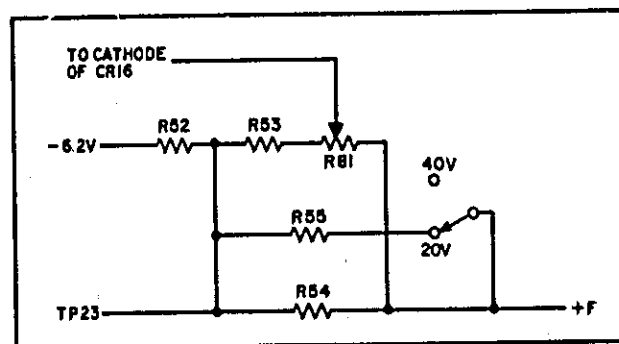

Note that in Paragraph 5-52, Step e, the Voltmeter should now read 2.55Vdc (1.25Vdc for Model 6206B).

CHANGE 5:

In replaceable parts list, make the following changes:

Add: CR6, Rect. Si. 200mA 10prv, 1N4830, G. E.
 C Part No. 1901-0461.

Add: CR7, Rect. Si. 100mA 15prv, 1N4828, G. E.
 C Part No. 1901-0460.

Delete: Q5, Q17, R35, R52, R85, R86.

Change:

R3, 4: $23K_{\Omega} \pm 1\%$ $\frac{1}{8}W$, Sprague, C Part No. 0698-3269.

R29: $6.2K_{\Omega} \pm 5\%$ $\frac{1}{2}W$, EB-6225, A. B., C Part No. 0686-6225.

R34: $220_{\Omega} \pm 5\%$ $\frac{1}{2}W$, EB-2215, A. B., C Part No. 0686-2215.

R47: $750_{\Omega} \pm 5\%$ $\frac{1}{2}W$, EB-7515, A. B., C Part No. 0686-7515.

CHANGE 5: (Continued)

R56: $1.69K_{\Omega} \pm 1\%$ 1/8W, Sprague, $\text{\textcircled{C}}$ Part No.
0698-4428.

R57: $3.57K_{\Omega} \pm 1\%$ 1/8W, Sprague, $\text{\textcircled{C}}$ Part No.
0698-3496.

R58: $196_{\Omega} \pm 1\%$ 1/8W, Sprague, $\text{\textcircled{C}}$ Part No.
0698-3340.

On schematic, make the following changes:

A. Connect CR6 and CR7 in series aiding. Con-

nect the anode of one to the emitter of Q3 and the cathode of the other to +S (remaining anode and cathode tied together).

B. Short Q5 base to emitter. Open collector lead of Q5.

C. Open all leads of Q17.

D. Open R35.

E. Open R52.

F. Open R85.

G. Open R86.

H. Remove R29 and connect it from the emitter of Q3 to 12.4 reference voltage.

SECTION VII CIRCUIT DIAGRAMS

This section contains the circuit diagrams necessary for the operation and maintenance of this power supply. Included are:

a. Component Location Diagram, Figure 7-1, which shows the physical location and reference designator of parts mounted on the printed

wiring board.

b. Schematic Diagram, Figure 7-2, which illustrates the circuitry for the entire power supply. Voltages are given adjacent to test points, identified by encircled numbers on the schematic and printed wiring board.

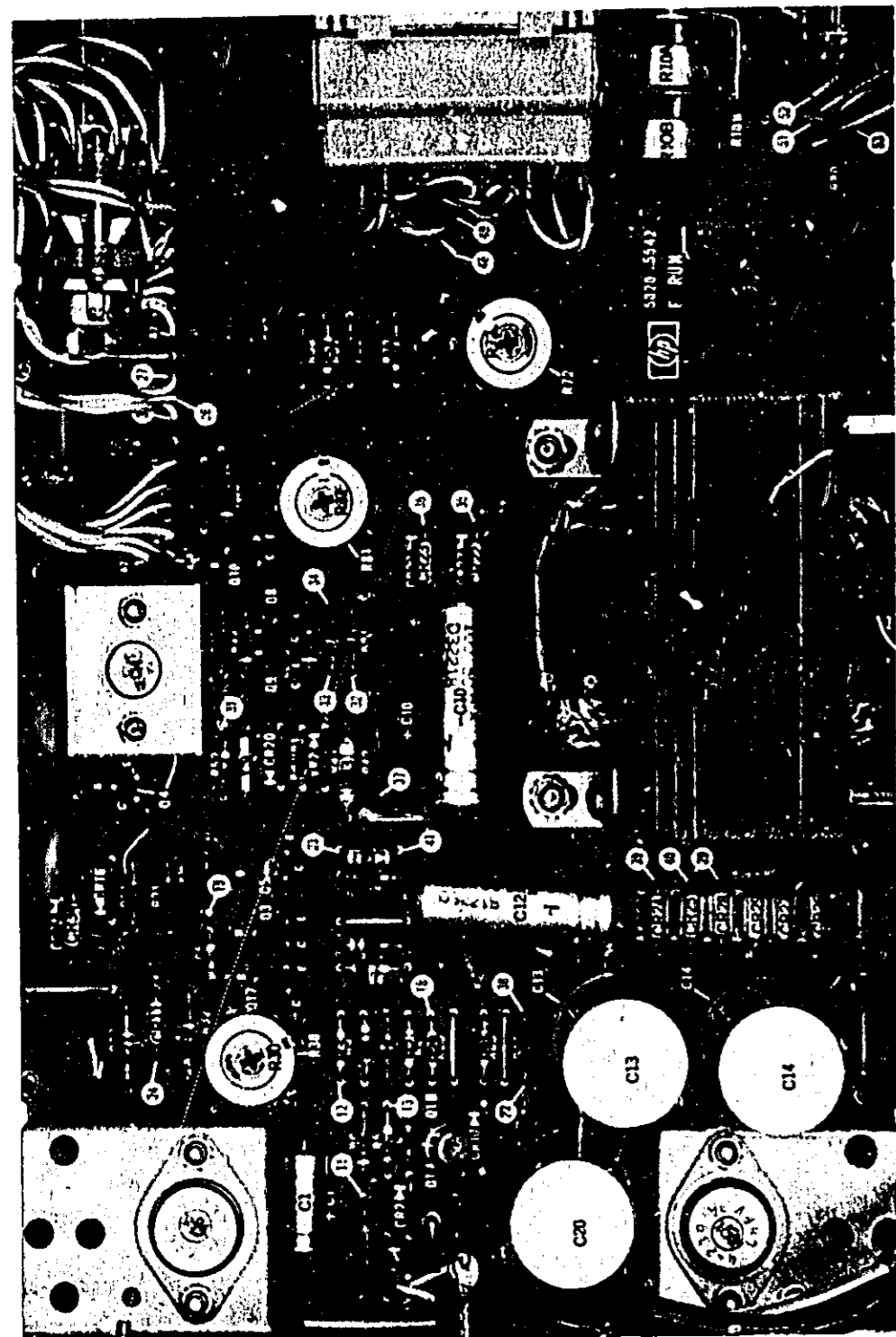

Figure 7-1. Component Location Diagram

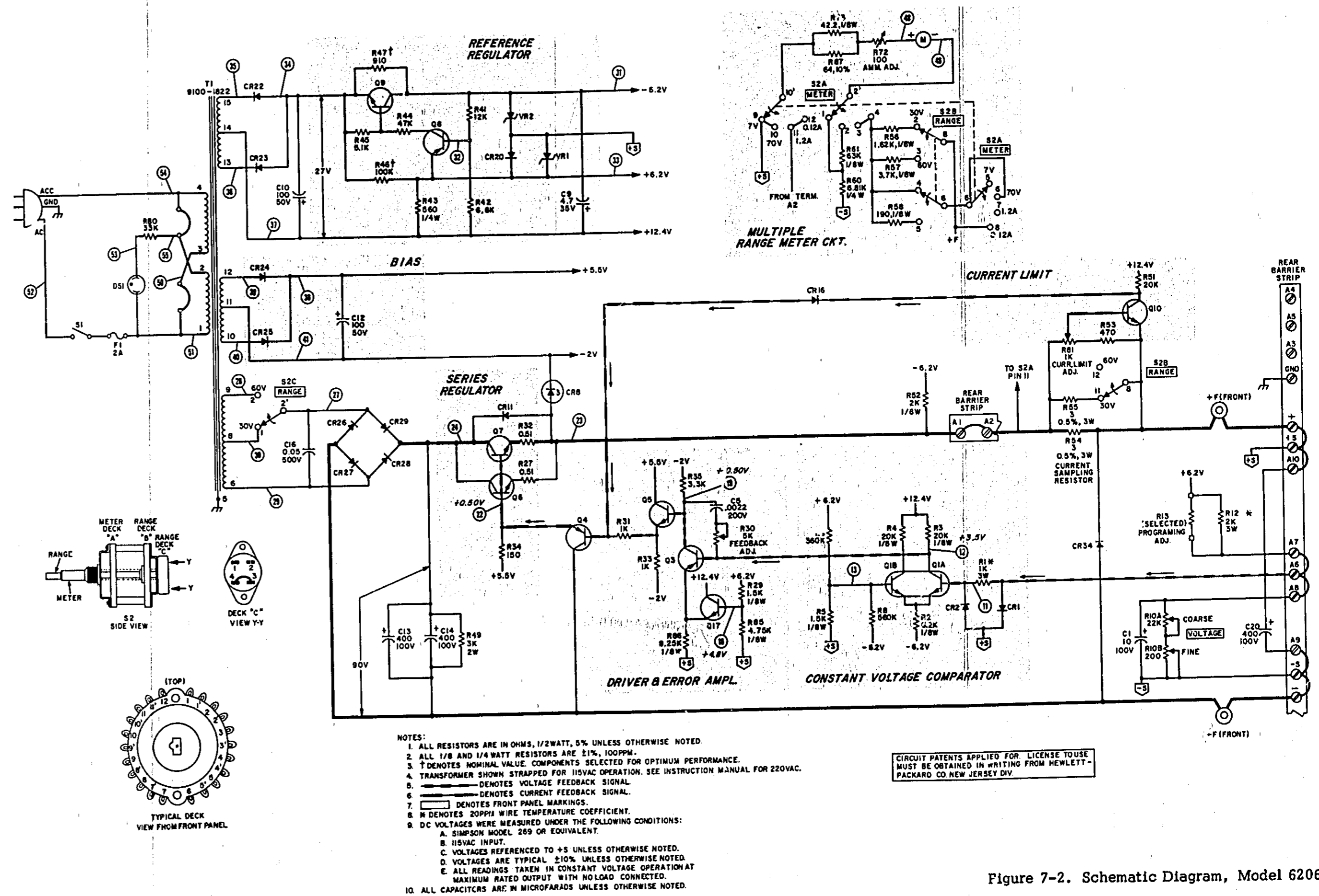

Figure 7-2. Schematic Diagram, Model 6206B

MANUAL CHANGES

Model 6206B DC Power Supply
HP Manual Part No. 06206-90002

Make all corrections in the manual according to errata below, then check the following table for your power supply serial number and enter any listed change(s) in the manual.

SERIAL		MAKE CHANGES
Prefix	Number	
8M	2952-3131	1
8M	3132-3281	1,2
1145A	3282-5640	1,2,3,4
1928A	5645-5650, 5653, 5655-5666, 5675-5677, 5679-5680, 5685-5690	1 thru 5
1928A	5641-5644, 5651-5652, 5654, 5667-5674, 5678, 5681-5684	1 thru 6
1933A	5659-5990	1 thru 6
2006A	5991-6140	1 thru 6
2041A	6141-6960	1 thru 7
2228A	6961- up	1 thru 8

CHANGE 1:

In the replaceable parts list, make the following change:

Terminal Strip: Add, HP Part No. 0360-0401.

CHANGE 2:

In the replaceable parts table, change power transformer T1 to HP Part No. 06206-80091.

CHANGE 3:

The Serial Prefix of this unit has been changed to 1145A. This is the only change.

CHANGE 4:

In Appendix A, Option 1; Replaceable Parts Table A-1, change CR4 from HP Part No. 1884-0031 to 1884-0032.

ERRATA:

In parts list, change HP Part No. of rubber bumper (qty. 4) to 0403-0002.

In Figure 3-9, connect jumper between the + and +S terminals. In Figure 5-4, change R_x listed for Model 6206B to 3 ohms.

In Table 1-1, change the INTERNAL IMPEDANCE AS A CONSTANT VOLTAGE SOURCE (Output Impedance) specification to read as follows:

Output Impedance (Typical): Approximated by a 40 milliohm resistance in series with a 1 microhenry inductance.

The standard colors for this instrument are now mint gray (for front panel) and olive gray (for all other external surfaces). Option X95 designates use of the former color scheme of light gray and blue gray. Option A85 designates use of a light gray front panel with olive gray used for all other external surfaces. New part numbers are shown below:

DESCRIPTION	HP PART NO.		
	STANDARD	OPTION A85	OPTION X95
Front Panel, Lettered	06206-60004	06206-60001	←
Heat Sink Rear	5060-7965	←	5060-6120
Chassis, Right Side	5060-7956	←	5060-6118
Chassis, Left Side	5060-7955	←	5060-6119
Cover, Top	5000-9424	←	5000-6061
Rack Kit (accessory)	14523A	14523A-A85	←

Effective January 1st, 1977, Option 007 (10-turn voltage control) has been redesignated Option 009, and Option 013 (10-turn voltage control with decadal) has been redesignated Option 015. Make these changes wherever Option 007 or 013 is mentioned in the manual.

The front panel binding posts have been changed to a type with better designed insulation. Delete the two types of posts listed on page 6-6 of the parts list and add: black binding post, HP Part No. 1510-0114 (qty. 2); and red binding post, HP Part No. 1510-0115 (qty. 1).

Change the part number of pilot light DSI to 1450-0566. This new light is more reliable than the former one.

The blue-gray meter bezel has been replaced by a black one, HP Part No. 4040-0414.

The corrugated shipping carton for this model has been changed to HP Part No. 9211-2570. Two 9220-2703 floater pads are used.

For all instruments delivered on or after July 1, 1978, change the HP Part No. for fuseholder from 1400-0084 to fuseholder body 2110-0564 and fuseholder carrier 2110-0565. Change the HP Part No. for fuseholder nut from 2950-0038 to 2110-0569. If old fuseholder must be replaced for any reason, replace complete fuseholder and nut with new fuseholder parts. Do not replace new parts with old parts.

CHANGE 5:

In the parts list, change the HP Part No. for the binding posts and associated hardware to the following:
Red binding post, qty 2 : 1510-0091
Terminal lug, qty 2 : 0360-0042
Lockwasher, qty 2: 2190-0079

Black binding post, qty 1 : 1510-0107
Terminal lug, qty 1 : 0360-1190
Nut, qty 3 : 2950-0144

CHANGE 6

In the replaceable parts list and on the schematic, change HP Part numbers and values as follows:
Q4 Change to 1853-0328
R31, R33 Change to 0688-5115, 510 ohm
R34 Change to 0688-1316, 130 ohm
Add 5000-9424 heatsink for Q4.
Parts are not interchangeable.

CHANGE 7:

In the replaceable parts list, change switch S1 to HP Part Number 3101-2424. On the Schematic diagram, change S1 to show two switch sections, one which breaks the AC Line (as shown), the other breaks the ACC Line.

CHANGE 8:

In the replaceable parts list and on the schematic, change R 10 to var. wv 20k ten-turn HP P/N 2100-1867 qty 1. Also delete: Knob 17/64 insert and Knob 3/16 insert.
Add: Knob, round HP P/N 0370-0137 qty 1.
This change eliminates Option 009 because Option 009 is now standard equipment.

5/28/82