

Keysight L4400 Series LXI Class C Instruments

User's Guide

Notices

Copyright Notice

© Keysight Technologies 2006-2021
No part of this manual may be reproduced in any form or by any means (including electronic storage and retrieval or translation into a foreign language) without prior agreement and written consent from Keysight Technologies as governed by United States and international copyright laws.

Manual Part Number

34989-90000

Edition

Edition 5, November 2021

Printed in:

Printed in Malaysia

Published by:

Keysight Technologies
Bayan Lepas Free Industrial Zone,
11900 Penang, Malaysia

Technology Licenses

The hardware and/or software described in this document are furnished under a license and may be used or copied only in accordance with the terms of such license.

Declaration of Conformity

Declarations of Conformity for this product and for other Keysight products may be downloaded from the Web. Go to <http://www.keysight.com/go/conformity>. You can then search by product number to find the latest Declaration of Conformity.

U.S. Government Rights

The Software is “commercial computer software,” as defined by Federal Acquisition Regulation (“FAR”) 2.101. Pursuant to FAR 12.212 and 27.405-3 and Department of Defense FAR Supplement (“DFARS”) 227.7202, the U.S. government acquires commercial computer software under the same terms by which the software is customarily provided to the public. Accordingly, Keysight provides the Software to U.S. government customers under its standard commercial license, which is embodied in its End User License Agreement (EULA), a copy of which can be found at <http://www.keysight.com/find/sweula>. The license set forth in the EULA represents the exclusive authority by which the U.S. government may use, modify, distribute, or disclose the Software. The EULA and the license set forth therein, does not require or permit, among other things, that Keysight: (1) Furnish technical information related to commercial computer software or commercial computer software documentation that is not customarily provided to the public; or (2) Relinquish to, or otherwise provide, the government rights in excess of these rights customarily provided to the public to use, modify, reproduce, release, perform, display, or disclose commercial computer software or commercial computer software documentation. No additional government requirements beyond those set forth in the EULA shall apply, except to the extent that those terms, rights, or licenses are explicitly required from all providers of commercial computer software pursuant to the FAR and the DFARS and are set forth specifically in writing elsewhere in the EULA. Keysight shall be under no obligation to update, revise or otherwise modify the Software. With respect to any technical data as defined by FAR 2.101, pursuant to FAR 12.211 and 27.404.2 and DFARS 227.7102, the U.S. government acquires no greater than Limited Rights as defined in FAR 27.401 or DFAR 227.7103-5 (c), as applicable in any technical data.

Warranty

THE MATERIAL CONTAINED IN THIS DOCUMENT IS PROVIDED “AS IS,” AND IS SUBJECT TO BEING CHANGED, WITHOUT NOTICE, IN FUTURE EDITIONS. FURTHER, TO THE MAXIMUM EXTENT PERMITTED BY APPLICABLE LAW, KEYSIGHT DISCLAIMS ALL WARRANTIES, EITHER EXPRESS OR IMPLIED, WITH REGARD TO THIS MANUAL AND ANY INFORMATION CONTAINED HEREIN, INCLUDING BUT NOT LIMITED TO THE IMPLIED WARRANTIES OF MERCHANTABILITY AND FITNESS FOR A PARTICULAR PURPOSE. KEYSIGHT SHALL NOT BE LIABLE FOR ERRORS OR FOR INCIDENTAL OR CONSEQUENTIAL DAMAGES IN CONNECTION WITH THE FURNISHING, USE, OR PERFORMANCE OF THIS DOCUMENT OR FOR ANY INFORMATION CONTAINED HEREIN. SHOULD KEYSIGHT AND THE USER HAVE A SEPARATE WRITTEN AGREEMENT WITH WARRANTY TERMS COVERING THE MATERIAL IN THIS DOCUMENT THAT CONFLICT WITH THESE TERMS, THE WARRANTY TERMS IN THE SEPARATE AGREEMENT SHALL CONTROL.

Safety Information

CAUTION















A CAUTION notice denotes a hazard. It calls attention to an operating procedure, practice, or the like that, if not correctly performed or adhered to, could result in damage to the product or loss of important data. Do not proceed beyond a CAUTION notice until the indicated conditions are fully understood and met.

WARNING

A WARNING notice denotes a hazard. It calls attention to an operating procedure, practice, or the like that, if not correctly performed or adhered to, could result in personal injury or death. Do not proceed beyond a WARNING notice until the indicated conditions are fully understood and met.

Safety Symbols

The following symbols on the instrument and in the documentation indicate precautions which must be taken to maintain safe operation of the instrument.

	Direct current (DC)		Alternating current (AC)
	Off (mains supply)		On (mains supply)
	Caution, risk of electric shock		Caution, risk of danger (refer to this manual for specific Warning or Caution information)
	Earth (ground) terminal		Frame or chassis (ground) terminal
	Protective earth (ground) terminal		Equipment protected throughout by double insulation or reinforced insulation
	Both direct and alternating current		Out position of a bi-stable push control
	Caution, hot surface		In position of a bi-stable push control

Safety Considerations

Read the information below before using this instrument.

The following general safety precautions must be observed during all phases of operation, service, and repair of this instrument. Failure to comply with these precautions or with specific warnings elsewhere in this manual violates safety standards for design, manufacture, and intended use of the instrument. Keysight Technologies assumes no liability for the customer's failure to comply with these requirements.

WARNING

Do not use this products in any manner not specified by the manufacturer. The protective features of this product may be impaired if it is used in a manner not specified in the operation instructions.

CAUTION

BEFORE APPLYING POWER.

Verify that the product is set to match the available line voltage and that the correct fuse is installed.

CAUTION

GROUND THE INSTRUMENT.

This product is provided with protective earth terminals. To minimize shock hazard, the instrument must be connected to the ac power mains through a grounded power cable, with the ground wire firmly connected to an electrical ground (safety ground) at the power outlet. Any interruption of the protective (grounding) conductor or disconnection of the protective earth terminal will cause a potential shock hazard that could result in personal injury.

CAUTION

DO NOT OPERATE IN AN EXPLOSIVE ATMOSPHERE.

Do not operate the instrument in the presence of flammable gases or fumes.

CAUTION**DO NOT REMOVE THE INSTRUMENT COVER.**

Only qualified, service-trained personal who are aware of the hazards involved should remove instrument covers. Always disconnect the power cable and any external circuits before removing the instrument cover.

CAUTION**DO NOT MODIFY THE INSTRUMENT**

Do not install substitute parts or perform any unauthorized modification to the product. Return the product to an Keysight Sales and Service Office for service and repair to ensure that safety features are maintained.

WARNING

No operator serviceable parts inside. Return the instrument to a Keysight Technologies Sales and Service Office for service and repair to ensure that safety features are maintained in operational condition.

WARNING

Do not use the instrument if it is damaged. Before you use the instrument inspect all connections. Pay particular attention to the insulation surrounding connectors.









WARNING

NEVER use a cable showing any sign of damage. Faulty cables can cause electrical shock and/or fire hazards and could lead to personal injury or death.

NOTE

Safety of any system incorporating the equipment is the responsibility of the assembler of the system.

Regulatory Markings

 <p>The CE mark is a registered trademark of the European Community. This CE mark shows that the product complies with all the relevant European Legal Directives.</p>	 <p>The CSA mark is a registered trademark of the Canadian Standards Association.</p>
 <p>The CE mark is a registered trademark of the European Community. This CE mark shows that the product complies with all the relevant European Legal Directives.</p> <p>ICES/NMB-001 indicates that this ISM device complies with the Canadian ICES-001. Cet appareil ISM est conforme a la norme NMB-001 du Canada.</p> <p>ISM GRP.1 Class A indicates that this is an Industrial Scientific and Medical Group 1 Class A product.</p>	<p>ICES/NMB-001</p> <p>ICES/NMB-001 indicates that this ISM device complies with the Canadian ICES-001. Cet appareil ISM est conforme a la norme NMB-001 du Canada.</p>
 <p>This symbol is a South Korean Class A EMC Declaration. This is a Class A instrument suitable for professional use and in electromagnetic environment outside of the home.</p>	 <p>The RCM mark is a registered trademark of the Australian Communications and Media Authority.</p>
 <p>This symbol indicates the time period during which no hazardous or toxic substance elements are expected to leak or deteriorate during normal use. Forty years is the expected useful life of the product.</p>	 <p>This instrument complies with the WEEE Directive (2002/96/EC) marking requirement. This affixed product label indicates that you must not discard this electrical or electronic product in domestic household waste.</p>
 <p>The CE marking is a legal compliance marking of the European Community. This CE marking shows that the product complies with all the relevant European Legal Directives.</p>	

Waste Electrical and Electronic Equipment (WEEE) Directive

The crossed out wheeled bin symbol indicates that separate collection for waste electric and electronic equipment (WEEE) is required, as obligated by the EU DIRECTIVE and other National legislation.

Please refer to [keysight.com/go/takeback](https://www.keysight.com/go/takeback) to understand your Trade in options with Keysight in addition to product takeback instructions.



Sales and Technical Support

To contact Keysight for sales and technical support, refer to the support links on the following Keysight websites:

- www.keysight.com/find/L4400
(product-specific information and support, software and documentation updates)
- www.keysight.com/find/assist
(worldwide contact information for repair and service)

THIS PAGE HAS BEEN INTENTIONALLY LEFT BLANK.

Table of Contents

Safety Symbols	3
Safety Considerations	4
Regulatory Markings	6
Waste Electrical and Electronic Equipment (WEEE) Directive	7
Sales and Technical Support	7
1 Introduction to the L4400 Series LXI Instruments	
Instrument Considerations	24
Environmental Operating Conditions	24
Electrical Operating Conditions	25
Interconnection Solutions Overview	28
Bench-Top Operation and Instrument Rack Mounting	30
Bench-Top Operation	30
Rack Mounting	31
Procedure	31
Applying Power	37
Connecting the Power Cord and Turning On the Instrument	37
2 Software Installation and Configuration	
Installing the Keysight IO Libraries and L4400 Instrument Drivers	38
Configuring the L4400 Instruments	41
Selecting a LAN Network	41
Connecting the LAN Cables	42
IP Addresses and Host Names	44
Configuring the LAN Interface	46
Using the Instrument Web Interface	49
LAN Configuration Command Summary	52
GPIB Configuration	53
Firmware Updates	58
Instrument Power-On and Default LAN Configuration States	59

LAN Reset (Default) Configuration	59
3 Operating and Programming	
L4400 Instrument Front Panel Overview	74
The LAN Reset Button	74
The Front Panel LEDs	74
L4400 Instrument Rear Panel Overview	76
L4400 Series Channel Addressing Scheme	79
Introduction to the SCPI Command Language	80
Syntax Conventions	80
Command Separators	81
Using the MIN and MAX Parameters	82
Querying Parameter Settings	82
Specifying Channel Lists and Scan Lists	82
L4400 SCPI Command Summary	84
L4400 Series Programming Examples	88
Modifying IVI-COM Examples (.NET)	88
Modifying IVI-C Examples	90
Modifying VISA and VISA COM Examples	91
Using L4400 Instruments in Keysight 34980A Applications	93
Analog Bus Applications	95
Environmental Operating Conditions	95
Electrical Operating Conditions	96
Safety Interlock	98
User-Defined Channel Labels	100
Scanning Applications	101
Rules for Scanning	101
Creating the Scan List	103
Scan Trigger Source	104
Trigger Count	109
Sweep Count	109
Channel Delay	111
Reading Format	112
Non-Sequential Scanning	112

Monitor Mode	113
Scanning with External Instruments	115
Alarm Limits	118
Viewing Stored Alarm Data	121
Using the Alarm Output Lines	122
Using Sequences	124
Defining a Sequence	125
Querying the Sequence Definition	128
Executing a Sequence	128
Executing a Sequence on an Alarm Condition	129
Deleting Sequences	130
Reading the List of Stored Sequences	131
Instrument State Storage	132
Error Conditions	133
Relay Cycle Count	134
Calibration Overview	135
4 L4421A 40-Channel Armature Multiplexer	
Low Frequency Multiplexer Switch Instrument	134
L4421A Measurement Functions	135
L4421A SCPI Command Summary	136
L4421A Example Program Segments	139
L4421A 40-Channel Armature Multiplexer Hardware Description	141
L4421A Simplified Schematic	142
L4421A D-Sub Connectors	144
34921T Terminal Block	145
5 L4433A Dual/Quad 4x8 Reed Matrix	
Matrix Switch Instrument	146
L4433A SCPI Command Summary	147
L4433A Example Program Segments	149
Linking Multiple L4433A Instruments	152

L4433A Dual/Quad 4x8 Reed Matrix Hardware Description	153
L4433A Simplified Schematic for Two-Wire Mode	156
L4433A D-Sub Connectors for Two-Wire Mode	157
34933T-001 Terminal Block for Two-Wire Mode	158
L4433A Simplified Schematic for One-Wire Mode	160
L4433A D-Sub Connectors for One-Wire Mode	161
34933T-002 Terminal Block for One-Wire Mode	162
6 L4437A General Purpose Switch	
General Purpose Switch Instrument	164
L4437A SCPI Command Summary	166
L4437A Example Program Segments	168
L4437A 32-Channel General Purpose Switch Hardware Description	170
L4437A Simplified Schematic	170
L4437A D-Sub Connectors	171
34937T Terminal Block	172
7 L4445A Microwave Switch/Attenuator Driver	
L4445A SCPI Command Summary	174
L4445A Microwave Switch/Attenuator Driver	177
Recommended Switches and Attenuators	180
Power Supplies	181
Channel Numbering	183
Simple Switch Control	184
Remote Module Identifiers	185
Drive Modes	186
Using Single Drive Switches and Attenuators	186
Using Dual Drive Switches and Attenuators	187
Using Pulse Drive	188
Long Execution Times	190
Verifying Switch State	190
LED Drive	192
Default and Reset States	192
Distribution Boards	195

Y1150A	195
Y1151A	199
Y1152A	203
Y1153A	208
Y1154A	213
Y1155A	218
Mounting the Remote Modules	225
SCPI Programming Examples	227

8 L4450A 64-Bit Digital I/O with Memory and Counter

L4450A SCPI Command Summary	232
L4450A 64-Bit Digital I/O with Memory and Counter	243
Basic Digital I/O Operations	244
Handshaking	247
Buffered I/O Operations	255
Interrupt Lines	259
Byte Ordering	260
Pattern Matching	261
Counter	262
Initiated Measurement Mode	263
Clock	264
L4450A D-Sub Connectors	265
34950T Terminal Block	268

9 L4451A 4-Channel Isolated D/A Converter with Waveform Memory

L4451A 4-Channel Isolated D/A Converter with Waveform Memory	270
Level Output Mode	270
Waveform (Trace) Mode	270
Clock In	271
Clock Out	271
Trigger In	272
Trigger Out	272
L4451A SCPI Command Summary	273
L4451A Example Program Segments	276
L4451A Simplified Block Diagrams	279

L4451A D-Sub Connector Pinout	280
34951T Terminal Block	281
10 L4452A Multifunction Module with DIO, D/A, and Totalizer	
L4452A Multifunction Module	284
Digital Input/Output	284
Totalizer Input	284
Analog Output (DAC)	284
L4452A SCPI Command Summary	285
L4452A Example Program Segments	290
L4452A Simplified Block Diagram	292
L4452A D-Sub Connector	293
34952T Terminal Block	293
11 Appendix A	
L4451A and L4452A Calibration Procedures	
Calibration Procedures	296
Keysight Technologies Calibration Services	296
Calibration Interval	296
Time Required for Calibration	297
Automating Calibration Procedures	297
Recommended Test Equipment	297
Calibration Security	298
Calibration Message	299
Calibration Count	299
Calibration Process	300
Aborting a Calibration in Progress	300
Performance Verification Tests	301
L4451A and L4452A Performance Test Considerations	301
L4451A 4-Channel Isolated DAC Module	301
L4452A Multifunction Module	309

List of Figures

Figure 1-1	Y1160A Instrument Rack Mount Kit (L4400 Series).	.32
Figure 1-2	EIA Unit Indicators for Installing the Y1160A Rack Mount Kit.	.33
Figure 1-3	Rack Column and Shelf Rail Orientation.	.34
Figure 1-4	Installing the Shelf.	.35
Figure 1-5	Connecting the Terminal Block Support Sleeve.	.36
Figure 1-6	Location of the L4400 Series Instrument Standby Power Button.	.38
Figure 2-1	IO Icon on the Windows Taskbar Notification Area.	.39
Figure 2-2	Typical Private LAN Network Connections.	.43
Figure 2-3	Typical Site LAN Network Connections.	.44
Figure 2-4	LAN Instrument Dialog Box	.47
Figure 2-5	Keysight Interactive IO.	.48
Figure 2-6	L4450A Web Interface (Welcome Page).	.50
Figure 2-7	Viewing LAN Configuration Settings from the Web Interface.	.51
Figure 2-8	Changing the Instrument LAN Interface Configuration.	.52
Figure 2-9	Remote GPIB Instrument Dialog Box.	.54
Figure 2-10	Setting the GPIB Address Using the Interactive IO Window.	.55
Figure 2-11	Removing instrument in Keysight Connection Expert.	.56
Figure 2-12	Connecting to GPIB Address 10 using Interactive IO.	.57
Figure 3-1	L4400 Instrument Front Panel (L4421A shown).	.74
Figure 3-2	L4400 Instrument Rear Panel (L4421A shown).	.76
Figure 3-3	L4400 Analog Bus Port Pinouts.	.77
Figure 3-4	External Trigger and Alarm Port Pin Definitions.	.78
Figure 3-5	Changing the Instrument Address String (IVI-COM Programs).	.89
Figure 3-6	Changing the Address String (IVI-COM / Visual Basic.NET).	.90
Figure 3-7	Changing the Instrument Address String (IVI-C Programs).	.91
Figure 3-8	Changing the Instrument Address String (VISA	

	Programs).	92
Figure 3-9	Changing the Address String (VISA COM Programs).	93
Figure 3-10	Trigger-to-Trigger Interval.	105
Figure 3-11	Sweep Count Diagram.	110
Figure 3-12	Channel Delay.	111
Figure 3-13	Scanning with External Instruments.	115
Figure 3-14	External Scanning Using the L4421A and a DMM.	116
Figure 3-15	The L4400 Series Rear Panel Alarm Connector.	122
Figure 4-1	34921T Terminal Block.	146
Figure 6-1	5A Relay Power-Down State Jumper.	165
Figure 6-2	L4437A Terminal Block.	172
Figure 7-1	L4445A Microwave Switch / Attenuator Driver Configuration.	178
Figure 7-2	The 34945EXT Module.	179
Figure 8-1	L4450A Terminal Block.	268
Figure 9-1	L4451A Terminal Block.	281
Figure 10-1	L4452A Terminal Block.	294
Figure 11-1	L4451A Output Current Connections.	302
Figure 11-2	L4451A Output Voltage Connections.	303
Figure 11-3	L4452A DAC Output Connections (Channels 6 and 7).	
	309	

List of Tables

Table 1-1	L4400 Series LXI Instrument Voltage Ratings	24
Table 1-2	L4400 (Y1160A) Rack Mount Kit Contents	31
Table 1-3	Keysight L4400 Series Instrument Input Power Specifications	37
Table 2-1	L4400 Programming Environments and Recommended Drivers	40
Table 2-2	L4400 Instrument Power-on and Preset States	59
Table 2-3	Default LAN Configuration Settings	60
Table 3-1	L4400 LED Definitions and Instrument Status	75
Table 3-2	L4400 Series Channel Addressing Examples	79
Table 3-3	L4400 Series SCPI Command Summary	84
Table 3-4	Keysight L4400 Series and 34980A Module Cross Reference	93
Table 4-1	L4421A Supported Measurement Functions	135
Table 4-2	L4421A SCPI Command Summary	136
Table 5-1	L4433A SCPI Command Summary	147
Table 6-1	L4437A SCPI Command Summary	166
Table 7-1	L4445A SCPI Command Summary	174
Table 8-1	L4450A SCPI Command Summary	232
Table 9-1	L4451A SCPI Command Summary	273
Table 10-1	L4452A SCPI Command Summary	285
Table 11-1	Recommended Test Equipment	297
Table 11-2	L4451A Output Current and Voltage Levels	304
Table 11-3	L4451A DAC Voltage Calibration Points	307
Table 11-4	L4451A DAC Current Calibration Points	308
Table 11-5	L4452A Output Voltage Levels (Channels 6 and 7)	310

THIS PAGE HAS BEEN INTENTIONALLY LEFT BLANK.

1 Introduction to the L4400 Series LXI Instruments

Instrument Considerations	24
Interconnection Solutions Overview	28
Bench-Top Operation and Instrument Rack Mounting	30
Applying Power	37

Welcome. The products covered in this user's guide represent the Keysight L4400 Series of LXI Class C instruments. LXI, an acronym for LAN eXtensions for Instrumentation, is an instrumentation standard for devices that use the Ethernet (LAN) as their primary communications interface.

The L4400 series family of instruments provide switching and multifunction test capabilities for design verification, automated test, and data acquisition applications. The instruments include:

- L4421A 40-Channel Armature Multiplexer Module
- L4433A Dual/Quad 4x8 Reed Matrix Module*
- L4437A 32-Channel General Purpose Switch Module*
- L4445A Microwave Switch/Attenuator Driver Module
- L4450A 64-Bit Digital I/O Module with Memory and Counter*
- L4451A 4-Channel Isolated D/A Converter w/ Waveform Memory Module*
- L4452A Multifunction Module*

This chapter contains general information on instrument environmental and electrical operating conditions, instrument interconnections, and rack mounting instructions. The chapter also contains information on applying power.

*Discontinued or obsolete product.

Instrument Considerations

This section lists important items and actions that can affect the operation of your modules.

Environmental Operating Conditions

The L4400 Series LXI modules are designed to operate in a temperature range of 0 °C to +55 °C with non-condensing humidity. At altitude up to 2000 m, the maximum relative humidity (non-condensing) is 80%RH up to 40 °C and decreases linearly to 37%RH at 55°C*. Do not use in locations where conductive dust or electrolytic salt dust may be present.

The modules should be operated in an indoor environment where temperature and humidity are controlled. Condensation can pose a potential shock hazard. Condensation can occur when the modules are moved from a cold to a warm environment, or if the temperature and/or humidity of the environment changes quickly.

The following table shows maximum voltage ratings for each module. If conditions change, ensure that condensation has evaporated and the instrument has thermally stabilized until pollution degree 1 or 2, as applicable, conditions are restored before turning on power to the equipment.

*From 40°C to 55°C, the maximum % Relative Humidity follows the line of constant dew point.

Table 1-1 L4400 Series LXI Instrument Voltage Ratings

Instrument	Pollution Degree 1 Specifications	Pollution Degree 2 Specifications
L4421A	40 channels, 300V rms or DC, 1A switch, 2A carry (continuous), max 60VA/channel, max 1000Vpk transient	40 channels, 100V rms or DC, 1A switch, 2A carry, max 60VA/channel, max 1000Vpk transient
L4433A	Dual/quad 4x8 matrix, 150 Vpeak, 0.5A, 10 VA/channel	Dual/quad 4x8 matrix, 100 Vpeak, 0.5 A, 10 VA per channel
L4437A	28 channels, 300 V rms or DC, 1A, 60 VA per channel 4 channels, 250 V rms or 30 VDC, 5A, 150 VA per channel	28 channels, 100 V rms or DC, 1A, 60 VA per channel 4 channels, 100 V rms or 30 VDC, 5A, 150 VA per channel
L4445A	See Chapter 7 - L4445A	See Chapter 7 - L4445A

Instrument	Pollution Degree 1 Specifications	Pollution Degree 2 Specifications
L4450A	64 channels, 5V, 30 mA Max	64 channels, 5V, 30 mA Max
L4451A	4 channels 16V, 20 mA	4 channels 16V, 20 mA
L4452A	32 DIO channels, 42V, 400 mA, 2 channel DAC, 12V, 10 mA	32 DIO channels, 42V, 400 mA, 2 channel DAC, 12V, 10 mA

NOTE

Pollution Degree 1: No pollution or only dry, non-conductive pollution occurs. The pollution has no influence (on insulation).

NOTE

Pollution Degree 2: Normally only non-conductive pollution occurs. Occasionally, a temporary conductivity (leakage current between isolated conductors) caused by condensation can be expected.

Electrical Operating Conditions

WARNING

To avoid electric shock, turn off the L4400 instrument and disconnect or de-energize all field wiring to the instrument and to the analog bus connector (if present) before removing any terminal block covers. Never operate the instrument without the terminal block covers securely installed. Failure to do so may lead to hazardous voltage signals that may result in fire hazards or shock hazards that could result in personal injury or death.

WARNING

Under certain conditions, dangerous voltage levels capable of causing injury or death may remain even after external circuits have been disconnected. To avoid injuries, always disconnect the power and discharge all circuits before touching them. Ensure no hazardous voltages remain on any accessible parts before handling any part of the instrument and test setup.

WARNING

This is a Safety Protection Class I Product (provided with a protective earthing ground incorporated in the power cord). The mains plug shall only be inserted in a socket outlet provided with a protective earth contact. Any interruption of the protective conductor inside or outside of the product is likely to make the product dangerous. Intentional interruption is prohibited.

The mains wiring and connectors shall be compatible with the connector used in the premise electrical system. Inadequate earth grounding can damage the instrument. Always use the three-prong AC power cord supplied with the instrument.

Connect the AC power cord as follow:

1. Ensure that the power cord is not damaged.
2. Install the signal generator so that one of the following items is readily identifiable and easily reached by the operator: AC power cord, alternative switch or circuit breaker.
3. Insert the mains plug into a socket outlet provided with a protective earth grounding.

WARNING

L4421A - Prevent operators from accessing any external circuits, test fixtures or cables or whenever dangerous voltage signals may be on the Analog Buses. Failure to recognize and observe normal safety precautions could result in personal injury or death.

Operators must not remove instrument covers. Component replacement and adjustments must be made by qualified personnel.

Transients

The L4421A, L4433A, and L4437A modules are designed to safely withstand occasional transient overvoltages up to 1000 V_{peak}. Typically, these transient overvoltages result from switching inductive loads or from nearby lightning strikes. The lightning-caused transient overvoltages that may occasionally occur on mains power outlets may be as high as 2500 V_{peak}.

The L4445A, L4450A, L4451A, and L4452A modules are intended for only low-voltage applications, and should not be connected to circuits that may generate or conduct large transient voltages.

High Energy Sources

These instruments are designed to handle inputs up to the rated max 2A or 60VA, whichever is less. Under certain fault conditions, high energy sources could provide substantially more current or power than a module can handle. It is important to provide external current limiting, such as fuses, if the instrument inputs are connected to high-energy sources.

CAUTION

Install current limiting devices between high energy sources and the module inputs.

CAUTION

Ensure that the current limiting devices / snubber circuits are appropriate for the signal being tested.

Interconnection Solutions Overview

Depending on your specific requirements, you can connect your DUT to the L4400 LXI instrument using the following optional interconnection solutions. See the L4400 series Product Data Sheets for additional information. The data sheets can be located on the Web at: www.keysight.com/find/L4400.

Terminal Blocks Detachable terminal blocks are available for most of the L4400 series instruments and offer a flexible method for connecting external wiring (300V rated). Each terminal block is customized for a specific module.

Ordering Information: 349xxT(e.g., 34921T, 34937T, etc.)

Shielded Cables Standard cables are available for 50-pin D-sub and 78-pin D-sub connectors. Depending on the module and your specific requirements, one or two cables may be required per module.

Ordering Information:

- Y1135A (1.5 meters, 50-pin D-sub, 300V)
- Y1136A (3 meters, 50-pin D-sub, 300V)
- Y1137A (1.5 meters, 78-pin D-sub, 300V)
- Y1138A (3 meters, 78-pin D-sub, 300V)

Solder Cup Connector Kits These connector kits are available if you want to build your own custom cables.

Ordering Information:

- Y1139A (50-pin D-sub female, 125V, for L4421A/L4433A/L4437A)
- Y1141A (50-pin D-sub male, 125V, for L4451A/L4452A)
- Y1142A (78-pin D-sub male, 60V, for L4450A)

L4445A Remote (Extender) Modules and Distribution Boards These kits expand the number of switches and attenuators controlled by the L4445A Microwave Switch/Attenuator Driver instrument.

Ordering Information:

- 34945EXT (External Driver)
- Distribution Boards:

- Y1150A (Eight N181x SPDT switches)
- Y1151A (Two 87104x/106x multiport or 87406B matrix switches)
- Y1152A (One 87204x/206x or 87606B switch and two N181x switches)
- Y1153A (Two 84904/5/6/7/8 or 8494/5/6 step attenuators)
- Y1154A (Two 87222 transfer switches and six N181x SPDT switches)
- Y1155A (Generic screw terminals for driving 16 switch coil)

Bench-Top Operation and Instrument Rack Mounting

The L4400 series instruments can be located on a bench-top or rack mounted in standard 19-inch EIA rack cabinets.

Ventilation Requirements When installing the instrument(s) into a cabinet consideration shall be given to the convection flow into and out of the cabinet. Consideration shall also be given to the individual instruments to void having the heated discharge of one instrument, now becoming the cooling intake air for another instrument.

Another area of concern is verification that the maximum ambient operating temperature of the instrument(s) is not exceeded by cabinet installation.

Keysight Technologies recommends forced air convection whenever an instrument(s) is installed in a cabinet and further recommends that the maximum operating temperature of the cabinet be reduced 10°C from the lowest of the maximum operating temperature of a single instrument.

If there are any concerns or special requirements a Keysight Field Engineer should be consulted to assure instrument(s) temperature compliance and performances.

Connecting the AC Power Cord Install the instrument so that the detachable power cord is readily identifiable and is easily reached by the operator. The detachable power cord is the instrument disconnecting device. It disconnects the mains circuits from the mains supply before other parts of the instrument. The front panel switch is only a standby switch and is not a LINE switch. Alternatively, an externally installed switch or circuit break (which is readily identifiable and is easily reached by the operator) may be used as a disconnecting device.

NOTE

The instrument shall be set flat in its normal use position so that the detachable power cord is readily identifiable and is easily reach by the operator.

Bench-Top Operation

Cooling and ventilation of the L4400 series instruments are through the sides of the instrument chassis. When placed on the bench-top, ensure the sides of the instrument are not directly covered or blocked.

Rack Mounting

The L4400 instruments are mounted in EIA rack cabinets using the Y1160A rack mount kit. The kit allows you to mount one or two L4400 instruments side-by-side on a sliding shelf, while occupying one EIA rack unit of space.

Rackmounting instructions are provided with the kit and are also provided here.

Rack Mounting Kit Contents

The contents of the Y1160A sliding shelf rack mount kit are listed in [Table 1-2](#).

Table 1-2 L4400 (Y1160A) Rack Mount Kit Contents.

Item	Description	Part Number	Quantity
1	M4x8 flat head screw	1515-1367	12
2	10-32 pan head dress screw	0570-1577	4
3	10-32 x 0.625 pan head screw	2680-0105	10
4	10-32 x 0.5 flat head screw	2510-0283	2
5	10-32 clip-on nut	0590-0804	12
6	10-32 nut w/lock washer	2740-0003	4
7	Sliding shelf	5180-0102	1
8	Shelf rails	5180-0103	2
9	Filler panels	5180-0104	2
10	Rear (rail) brackets	5180-0105	2
--	Installation Instructions	Y1160-90030	1

Procedure

[Figure 1-1](#) is a composite drawing of the Y1160A sliding shelf rack mount kit. The drawing shows the location/usage of the hardware items listed in [Table 1-2](#).

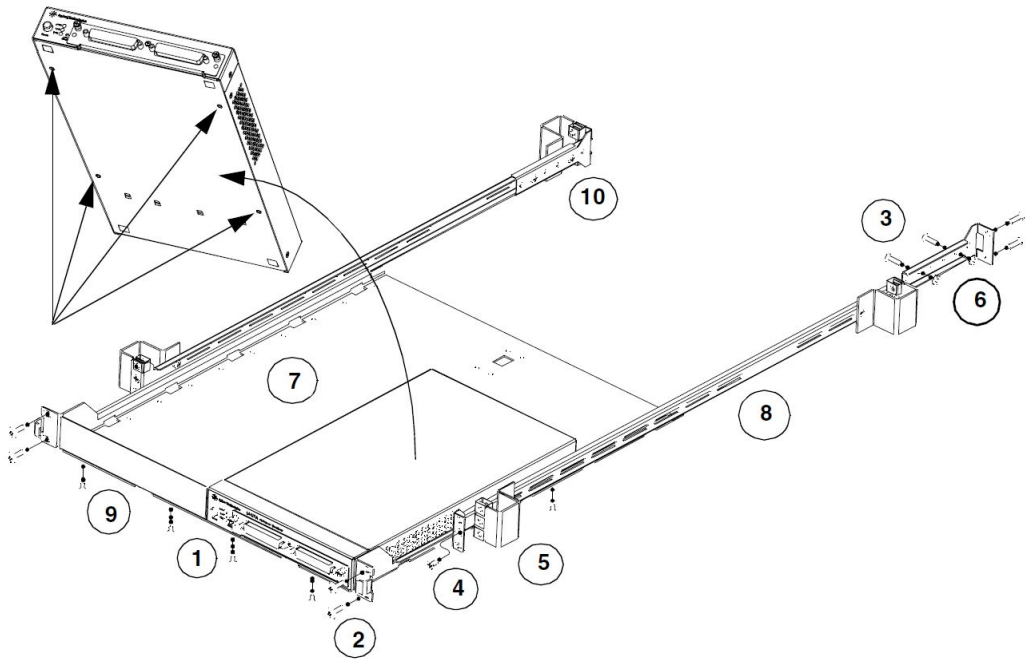

Figure 1-1 Y1160A Instrument Rack Mount Kit (L4400 Series).

The L4400 instrument(s) can be mounted between any two adjacent EIA unit indicators (Figure 1-2). On Keysight racks, an EIA unit indicator is represented by a triangle on the rack's front and rear-facing columns. A single EIA unit extends from the triangle indicator to the next indicator on the column (1 Unit = 44.45 mm = 1.75 in).

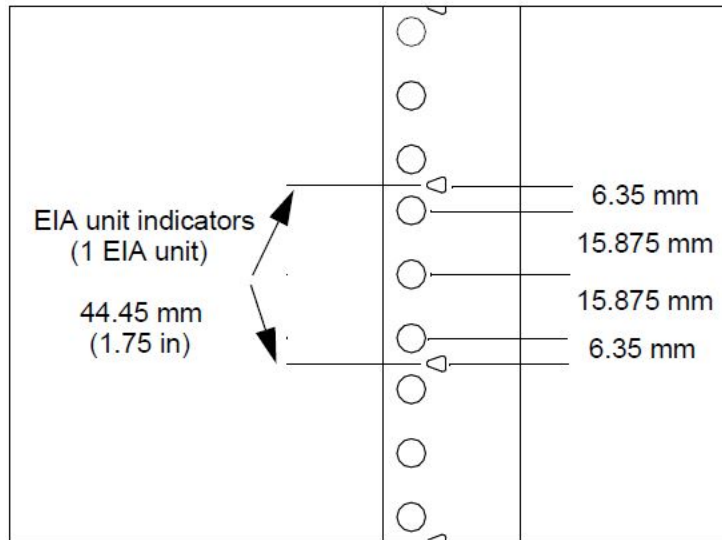

Figure 1-2 EIA Unit Indicators for Installing the Y1160A Rack Mount Kit.

NOTE

It is not necessary to remove the cabinet side panels to rack mount the L4400 instruments. The side panels can be removed, however, if additional access to the cabinet's vertical columns is desired.

Install the Shelf Rails

- 1 Select the vertical position in the rack between any two adjacent EIA unit indicators where the L4400 instrument is to be installed. Insert clip-on nuts (item 5) on the three holes between the unit indicators. Place nuts on both the left and right front-facing columns (Figure 1-3).

If center-facing columns with holes are present on the frame, insert a clip-on nut on the hole perpendicular to the center hole on the front facing column. See Figure 1-3.

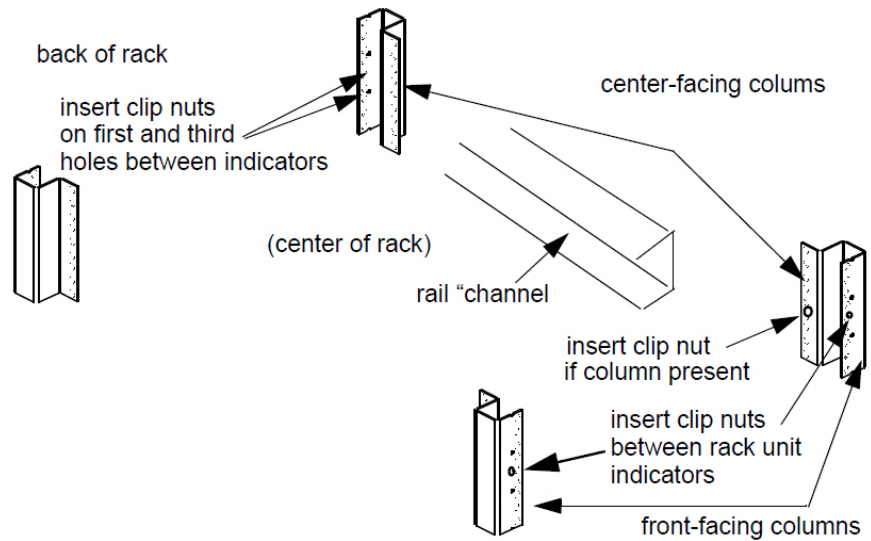

Figure 1-3 Rack Column and Shelf Rail Orientation.

- 2 With the rail “channel” facing the center of the rack, connect the rail to the front facing column using a 10-32 flathead screw (item 4) and the center clip-on nut on the front-facing column. Repeat for the rail on the opposite column. Ensure the rail channel faces the center of the rack.

If the rack has center-facing columns (Figure 1-3), insert a 10-32 pan head screw through the rail opening and clip nut (perpendicular to the front-facing column). Repeat for the rail on the opposite column.

- 3 On the rack’s rear-facing columns, insert clip-on nuts on the first and third holes between the EIA unit indicators that are at the same vertical position as the indicators on the front-facing columns.
- 4 Attach the rear brackets to the rail ends using two 10-32 pan head screws (item 3) and two 10-32 nuts with lockwashers (item 6) per rail. Adjust the bracket along the rail until the bracket end aligns with (covers) the rack’s rear-facing columns. Tighten the 10-32 pan head screws to firmly connect the bracket to the rail and maintain the rail length.

Connect the rail brackets to the rear-facing columns using two 10-32 pan head screws per column.

Install the Sliding Shelf

Facing the rack, slide the shelf (item 7) onto the bottom surfaces of the rail channels. The tabs at the back of the shelf pass underneath the channel surface. The tabs allow you to extend the shelf from the cabinet, thus providing a working surface for mounting the instruments.

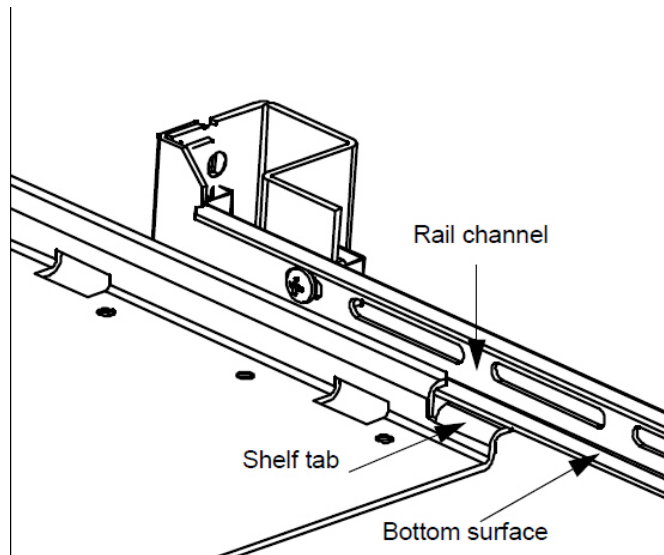

Figure 1-4 Installing the Shelf.

Install Instruments on the Shelf

The L4400 instruments can be installed flush (even) with front edge of the shelf, recessed in 50 mm increments, or reverse-mounted with the front of the instrument facing the back of the rack cabinet.

- 1** Extend the shelf from the rack such that approximately 50% - 75% of the shelf surface is outside of the rack. (The tabs on the back of the shelf that run underneath the rail channel prevent the shelf from tipping.)
- 2** Determine the position of the instruments (flush, recessed, reversed). To accommodate the terminal blocks (available with some of the L4400 instruments) and to simplify cable routing, it is recommended that the instruments be mounted flush (even) with the front or back edge of the shelf.

- 3 Note the location of the four mounting holes on the bottom of the instrument (Figure 1-1). Set the carrier on the shelf, and align the mounting holes with the holes on the shelf. Insert four M4x8 flat head screws (item 1) upward through the bottom of the shelf and into the carrier mounting holes.
- 4 Install the second L4400 instrument (if present) in the shelf area adjacent to the first instrument. If only one instrument is installed, install a filler panel on the front edge of the unused area. Insert two M4x8 flat head screws (item 1) upward through the bottom of the shelf and into the panel.
- 5 Connect the instrument power cord, LAN cable, and GPIB cable if present.
- 6 For instruments that have accompanying terminal blocks, partially remove the instrument sub-assembly from the instrument (carrier) by loosening the spring-loaded mounting screws (Figure 1-5). Remove the support sleeve from the terminal block. Locate and remove the flat head screws from the sleeve and remove the pan head screw from between the instrument's D-sub connectors (Figure 1-5). Connect the sleeve to the instrument using the flat head and pan head screws as shown. Reconnect the sub-assembly.

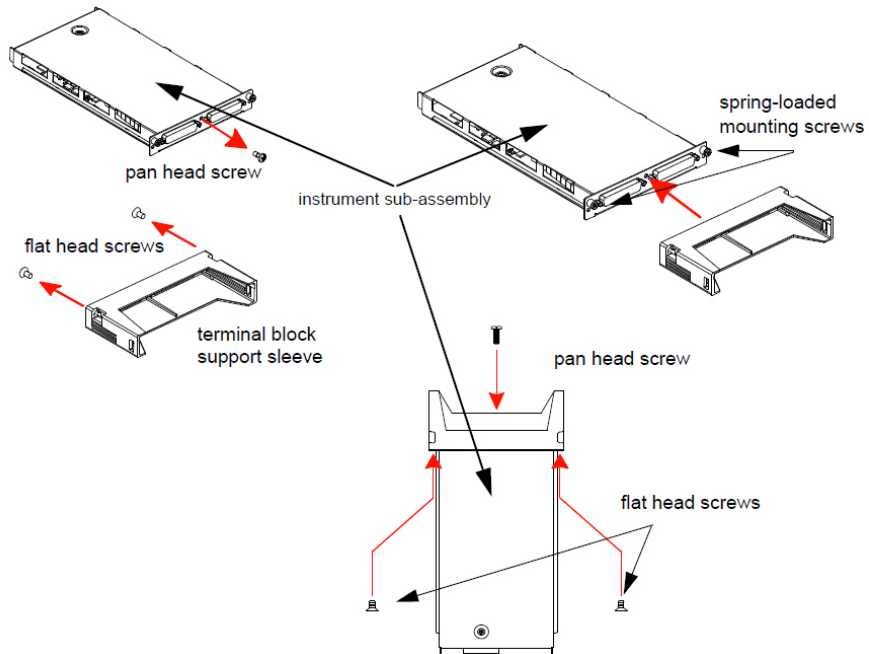

Figure 1-5 Connecting the Terminal Block Support Sleeve.

NOTE

Refer to Chapters 4-10 for information on Terminal Block wiring and connecting the terminal block to the instrument.

Connect the Shelf to the Rack Frame

Once the instruments are installed and all power cords and cables are routed as intended, slide the shelf into the cabinet until the shelf handles meet the front-facing columns of the rack frame. Using two 10-32 pan head dress screws (item 2) per column, secure the shelf to the frame.

Applying Power

The input power, operating environment, and storage environment specifications for the L4400 series instruments are listed in [Table 1-3](#). Refer to the instrument data sheets for a complete listing of instrument specifications. The data sheets can be found on the Web at: www.keysight.com/find/L4400.

Table 1-3 Keysight L4400 Series Instrument Input Power Specifications

Instrument	Description	
L4421A	Power Supply:	Universal 100V to 240V $\pm 10\%$
L4433A	Power Line Frequency:	50Hz to 60Hz auto sensing
L4437A	Power Consumption:	50VA
L4445A	Operating Environment:	Maximum Relative Humidity (non-condensing): 80%RH up to 40°C, decreases linearly to 37%RH at 55°C.*
L4450A		
L4451A		
L4452A	Storage Environment:	-40°C to 70°C

*From 40°C to 55°C, the maximum % Relative Humidity follows the line of constant dew point.

Connecting the Power Cord and Turning On the Instrument

1 Introduction to the L4400 Series LXI Instruments

Connect the power cord supplied with the instrument or a power cord rated for the conditions listed in [Table 1-3](#) to the electrical outlet and to the instrument. Cordset acts as a disconnect from mains.

Turn the instrument on (and off) by pressing the standby power button shown in [Figure 1-6](#).

Refer to [Table 3-1](#) (Chapter 3) for definitions of the LEDs (ATTN, LAN, PWR) on the L4400 instrument front panel.

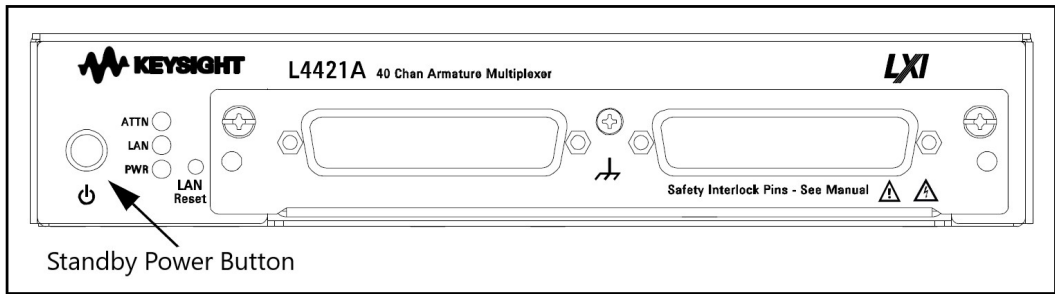

Figure 1-6 Location of the L4400 Series Instrument Standby Power Button.

2 Software Installation and Configuration

Installing the Keysight IO Libraries and L4400 Instrument Drivers	38
Configuring the L4400 Instruments	41
GPIB Configuration	53
Firmware Updates	58
Instrument Power-On and Default LAN Configuration States	59

This chapter contains the software installation and configuration procedures required for you to use the L4400 series instruments. Also included are procedures for configuring the LAN and (optional) GPIB interfaces, and for testing the communication (IO) paths to the instruments.

Installing the Keysight IO Libraries and L4400 Instrument Drivers

This section covers the sequence and procedures for installing the IO libraries and instrument drivers required to program the instruments.

NOTE

Ensure that the Keysight IO Libraries Suite is installed before you proceed for the remote interface configuration.

Keysight IO Libraries Suite is a collection of free instrument control software that automatically discovers instruments and allows you to control instruments over LAN, USB, GPIB, RS-232, and other interfaces. For more information, or to download IO Libraries, go to www.keysight.com/find/iosuite.

NOTE

You must have Administrator privileges to install Keysight IO Libraries Suite Connection Expert.

This section describes how to install Keysight IO Libraries Suite on your PC. The Keysight IO Libraries Suite is a collection of libraries and utilities that gives you the ability to use your instruments from the instrument control software.

You should install the Keysight IO Libraries Suite as your first step before installing the hardware because it installs the necessary software and drivers to control your instruments.

If possible, always use the most recent version of the Keysight IO Libraries Suite. This version supports the newest interfaces and operating systems, and has the most advanced features.

- 1 Verify that your PC meets the minimum system requirements. Refer to the IO Libraries Web page at www.keysight.com/find/iosuite or the IO Libraries Suite Readme.
- 2 Close all applications on your computer. Install the IO Libraries software from www.keysight.com/find/iosuite.
- 3 Follow the instructions as prompted during the installation. You can select either a Typical or a Custom installation:

Typical

In most cases, you can select the Typical installation which installs the IO Libraries Suite using the recommended settings.

Custom

Select the Custom installation to:

- a Install the IO Libraries Suite in another directory (for 32-bit operating systems only).
- b Save disk space by not installing interface manuals
- c Use Keysight 32-bit VISA with another vendor's VISA on the same PC in side-by-side mode. Details on the side-by-side mode are available at www.keysight.com/find/side-by-side-install or in the IO Libraries Suite help.

NOTE

Installing the Keysight IO Libraries also installs the Interchangeable Virtual Instrument (IVI) Shared Components. The IVI Shared Components are required before IVI drivers (e.g. IVI-COM, IVI-C) can be installed (see “Installing the L4400 Instrument Drivers”).

- 4 After the IO Libraries suite is successfully installed, you will see the IO icon on the Windows taskbar notification area.

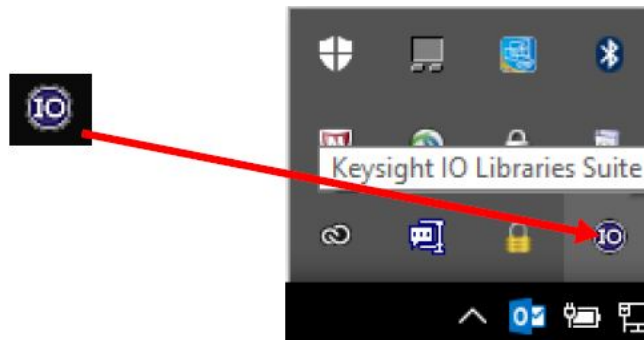

Figure 2-1 IO Icon on the Windows Taskbar Notification Area.

Table 2-1 L4400 Programming Environments and Recommended Drivers.

Programming Environment	Recommended Drivers
Microsoft® Visual C 6.0 Visual C++, ANSI C	IVI-C, IVI COM, VISA
Microsoft® Visual Basic 6.0	IVI-COM, VISA, VISA-COM
Microsoft Visual Studio .NET for C#, C, Visual Basic	IVI-COM
Keysight VEE	IVI-COM
National Instruments LabVIEW	LabVIEW Plug&Play (with L44XX native mode driver), IVI-C
National Instruments LabWindows/CVI	IVI-C

For information on firmware updates that may be available after purchase, refer to “[Firmware Updates](#)” at the end of this chapter.

Configuring the L4400 Instruments

Instrument configuration as applied to the L4400 series of LXI instruments involves the following:

- identifying the IP address and host name (LAN programming)
- (optional) setting the GPIB address
- testing the communication paths (LAN and/or GPIB) to the instrument
- opening the Web interface to the instrument

Each task listed above is accomplished using the Keysight Connection Expert Feature of the Keysight IO Libraries Suite.

The information included this section of the chapter is:

- Selecting a LAN Network
- Connecting the LAN Cables
- Configuring the LAN Interface
- GPIB Configuration

Selecting a LAN Network

This user's guide defines a private (isolated) LAN as a network in which instrument access is limited to a direct connection between the computer and the instrument, or to multiple instruments connected via a dedicated router or switch. A site (company-wide) LAN is defined as a network in which instrument access is available to many users in on-site and remote locations.

The instrument's application and/or your company's Information Technology (IT) department may have guidelines that help decide the type (private or site) of network used. If a network configuration has not been determined, refer to the following considerations concerning each type.

Private LAN Considerations

Some of the basic parameters of a private LAN network to consider are: security, performance, reliability, and IP address availability

Security: a private network generally involves direct connections between the computer and the instruments, and may include switches and routers. Access to

the instrument is limited to users connected directly to the private network, as opposed to users on a site network that could locate and access the instrument from any location - possibly disrupting tests in progress. Code generation for test systems on a private network is often simplified as protection against unauthorized users may not be required.

Performance: test systems where large amounts of data are transferred usually have faster throughput on a private network. On a site network, heavy and unpredictable LAN traffic (lots of data) affects each instrument (node) on the network. The impact on a test system is that repeatability is difficult to achieve as latencies are difficult to account for.

Reliability: private networks are fundamentally more reliable than site networks as they host fewer users and are less complex than site networks. Private networks are isolated from conditions that could bring down (crash) a site network.

IP Address Availability: Every instrument (node) on a LAN (private or site) has an IP (Internet Protocol) address. Due to the expanding use of the internet, the number of site network IP addresses available is limited. By using a router with Dynamic Host Configuration Protocol (DHCP) capability on a private network, the router can assign an IP address to each instrument thus creating a sub-network (subnet) that does not consume site IP addresses.

Site LAN Considerations

For applications requiring access by many users or by users at distributed sites, a site LAN network is required. In addition to supporting multiple users, site LANs often offer the advantage of being maintained by IT departments.

When using a site LAN, consult your IT department regarding all LAN configuration and security issues.

Connecting the LAN Cables

LAN cables are connected to the LAN terminal on the instrument, the computer, and to the router or switch if they are part of your network.

Private Network Connections

Figure 2-2 shows typical LAN cable connections for a private network.

Typical Private (isolated) LAN Networks

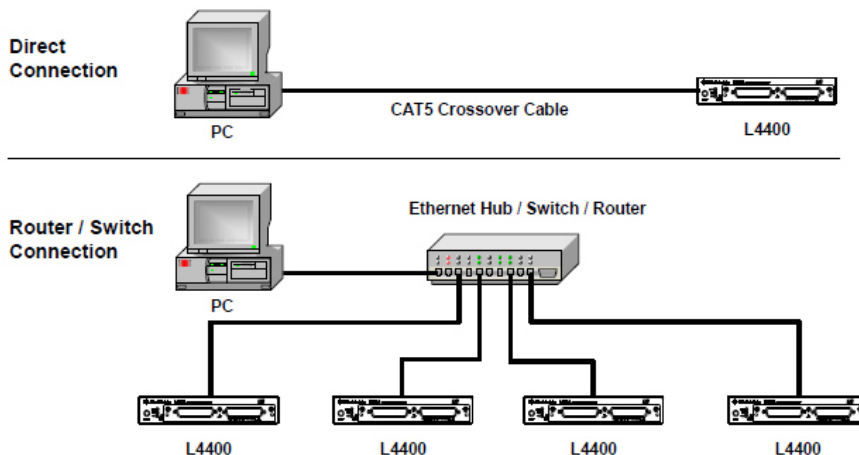

Figure 2-2 Typical Private LAN Network Connections.

When making a direct connection between the L4400 instrument and the PC, use the LAN crossover cable provided with the instrument. Note, if your computer supports Auto-MDIX or contains a LAN card with gigabit data transfer rates, the crossover cable is not required. A standard LAN cable can be used instead. For private LAN networks that include a switch or router, use standard LAN cables for network connections. Do not use the crossover cable.

Once the LAN cables are connected, you can turn on the L4400 instrument(s).

Site Network Connections

Figure 2-3 shows typical LAN cable connections for a site network.

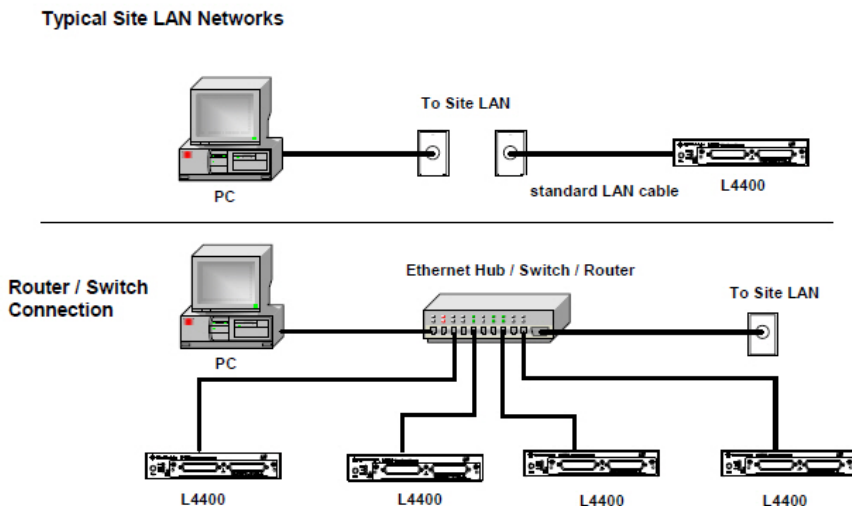

Figure 2-3 Typical Site LAN Network Connections.

On site networks, the L4400 instruments and the computer are connected directly to site LAN ports, or are connected to the site LAN through a switch. In each site network configuration, standard LAN cables are used.

Once all LAN cables are connected, turn on the L4400A instrument.

IP Addresses and Host Names

Dynamic Host Configuration Protocol (DHCP) and Automatic IP are enabled on each L4400 series instrument shipped from Keysight. This allows the instrument to automatically obtain an address on the network. If there is a DHCP server on the network, the server will assign the address to the instrument.

If there is not a DHCP server on the network, the L4400 instrument will automatically determine an address to use. The address will be in the range of

169.254.xxx.xxx. If available, the instrument will try to acquire its default setting of 169.254.44.88.

Host Names Each L4400 instrument has a default host name. The format of the host name is:

A-L44xxA-yyyyy

where 'L44xxA' is replaced by the module number (e.g. L4421A) and 'yyyyy' are the last five digits of the instrument serial number.

The instrument host name is reported by Keysight Connection Expert for network servers that support Dynamic Domain Name Service (DNS). For network servers that do not support Dynamic DNS, only the IP address is reported.

Instrument Addressing

During programming, an L4400 series instrument is accessed through its address string which consists of an IP address or host name. For example:

TCPIPO::192:168:1.221::inst0::INSTR

The L4400 series instruments can also be accessed using a host name as part of the address string. For example:

TCPIPO::A-L4450A-12345.Keysight.com::inst0::INSTR

NOTE

The L4400 instruments can be restored to their default configurations by pressing the 'Reset' pin on the instrument's front or rear panels.

Computer Configuration

Most computers used for instrument/system control are configured for LAN and Internet access. Before starting Keysight Connection Expert to locate and configure the instruments, verify that your computer is able to connect to the network that will include the instruments.

A Web browser is used to open web interfaces to the L4400 instruments (See "Using the Instrument Web Interface"). In some network configurations, a proxy server cannot be used to access the instrument IP addresses. In these situations, the browser must be set to disable the proxy for the instrument's address.

Configuring the LAN Interface

The Discovery Service automatically discovers many LAN instruments on the same subnet as the PC on which the service is running. However, LAN instruments are not automatically added to the instruments list during discovery. They must be added to the list manually.

NOTE

The procedure for using Keysight Connection Expert to locate and configure L4400 instruments is independent of the type of network you are using (private or site) and the network devices present (switches or routers).

For more information on Interactive IO, refer to the Keysight IO Libraries Suite Help. The guide is available on-line by clicking on the Keysight IO Control icon and then selecting Documentation > IO Libraries Suite Help.

Locating the Instruments

- 1 Launch **Keysight Connection Expert** from the Start menu or the Start Screen (Windows 8).
- 2 Select **+Add** on the **Keysight Connection Expert** toolbar.
- 3 Select **LAN instrument**.
- 4 See if the instrument is listed in the **Add a LAN Device** window. If the instrument(s) you want are listed in the Add a LAN Device list, click the check box for the instrument(s) then click OK.
- 5 If the instrument is still not listed, add the instrument manually. Select the **Manually Enter Address** tab.
- 6 Update the value in the **Hostname** or **IP Address** field. At this time, you can choose whether to allow ***IDN?** queries to be sent to the instrument to assist in identification.
- 7 Select **Test connection** to verify the connectivity and configuration of the LAN interface.

Add a LAN device [X]

Select from List | **Enter Address**

Set LAN Address:

Hostname or IP Address:

TCPIP Interface ID:

Set Protocol:

Instrument (VXI-11) Remote Name:

HiSlip Remote Name:

Socket Port Number:

Verify Connection:

Allow *IDN Query

View Web Page:

Figure 2-4 LAN Instrument Dialog Box

Interactive IO

The Interactive IO feature of Keysight Connection Expert allows you to interact with the instruments by sending commands and seeing the instruments' responses. Interactive IO can help you:

- troubleshoot communication problems
- learn the instrument's command set
- prototype commands and check the instrument's responses before writing code

With Interactive IO, you can choose from a menu of common commands (*IDN?, *RST, *TST?), or execute commands from the instrument's command set (see [Chapter 4](#) for the commands available with each instrument).

Starting Interactive IO

- 1 Launch **Keysight Connection Expert** from the Start menu or the Start Screen (Windows 8).
- 2 Right-click on the remote interface instrument and select **Send Commands To This Instrument** to display the **Keysight Interactive IO** dialog box.
- 3 Use the default command, ***IDN?** and select **Send & Read** to query the connected instrument.
- 4 The remote interface instrument identification information will appear on the **Instrument Session History** as shown in [Figure 2-5](#).
- 5 To send other commands, select **Commands>** to select from a list of common commands, or type a command into the **Command:** line.

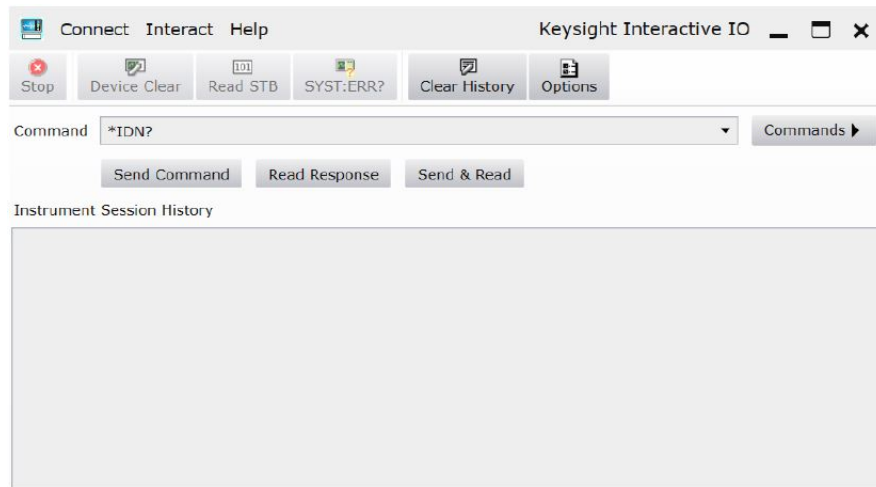

Figure 2-5 Keysight Interactive IO.

NOTE

For more information on Interactive IO, refer to the Keysight IO Libraries Suite Help. The guide is available on-line by clicking on the Keysight IO Control icon and then selecting Documentation > IO Libraries Suite Help.

Identifying the Instruments

L4400 series instruments are comprised of the carrier, the instrument sub-assembly, and on selected instruments, a wiring terminal block. The carrier and instrument sub-assembly have separate serial numbers and separate firmware revisions. The commands used to query these parameters are:

- `*IDN?` (returns the carrier serial number and firmware revision)
- `SYSTem:CTYPe? 1` (returns the instrument sub-assembly serial number and firmware revision)
- `SYSTem:CDEscription? 1` (returns the instrument description.)

These commands can be executed from the Interactive IO window. Examples of the information returned by each command are as follows:

`*IDN?`

Keysight Technologies, L4421A, MY00012345, 0.12-0.04-0.00-0.00
(L4421A = product), (MY00012345 = carrier serial number)
(0.12-0.04-0.00-0.00 = carrier firmware revision)

`SYST:CTYP?`

Keysight Technologies,L4421A, MY44000237, 2.16
(L4421A= product), (MY44000237 = sub-assembly serial number),
(2.16 = sub-assembly firmware revision)

`SYST:CDES? 1`

“40-Channel Armature Multiplexer with Low Thermal Offset”

Using the Instrument Web Interface

Each L4400 series instrument can be programmed using its Web-based interface. The Web interface functions as a virtual front panel which can also be used for:

- interactive control
- familiarization with instrument capabilities
- determining / changing instrument configuration
- troubleshooting and debugging

Comprehensive on-line help providing Web interface usage information is available with each Web window.

The instrument Web interface can be opened by selecting the instrument in Connection Expert and click the Web UI button. The Web interface can also be opened directly from a Web browser by entering the instrument's IP address or host name in the browser's 'Address' window.

An example of the Web interface window is shown in Figure 2-6.

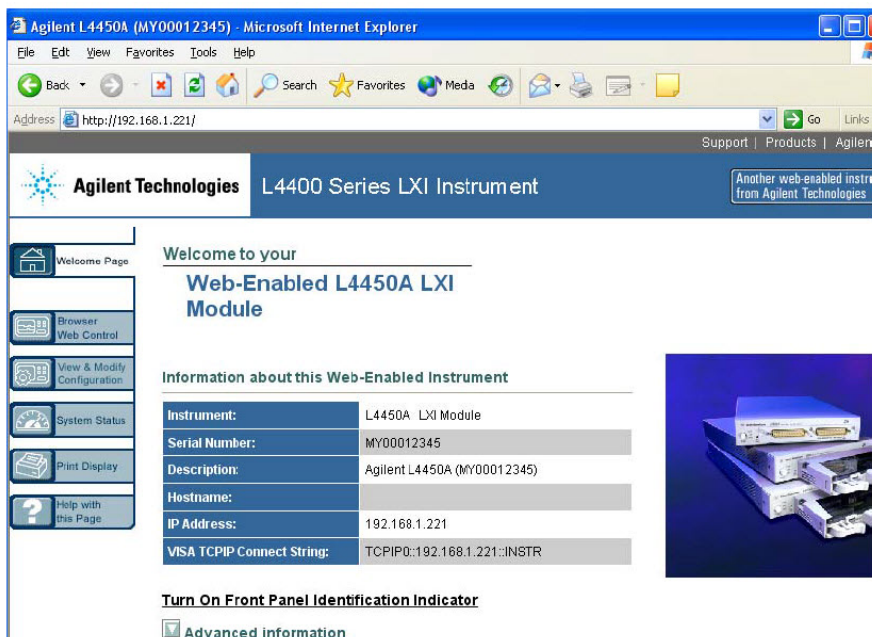

Figure 2-6 L4450A Web Interface (Welcome Page).

NOTE

Instruments on the network can be physically identified by selecting **Turn on Front Panel Identification Indicator** within the Web interface. This causes the instrument's front panel LAN LED to flash continually until **Turn off Front Panel Identification Indicator** is selected.

Editing the Instrument's LAN Settings

Once a communication path to the instrument has been opened, the instrument's LAN configuration can be viewed and modified using the Web interface.

On the Web "welcome page", click 'View and Modify Configuration'. This opens the configuration window shown in [Figure 2-7](#).

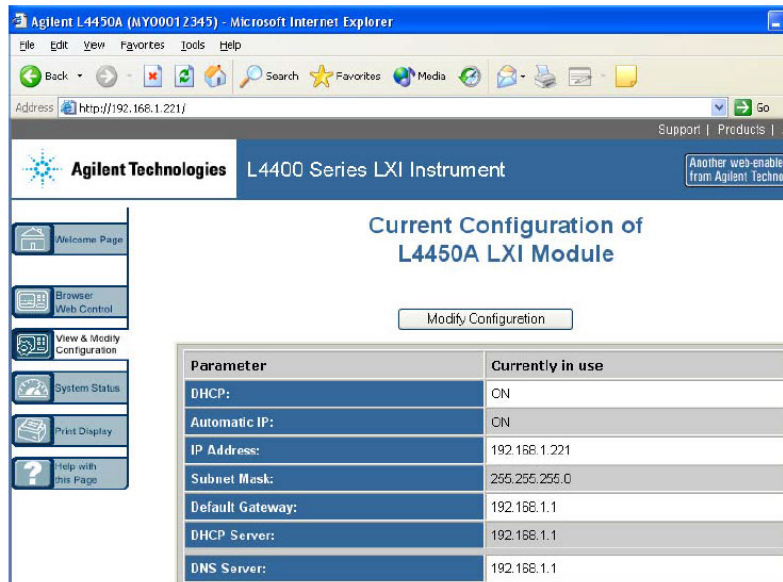

The screenshot shows a Microsoft Internet Explorer browser window displaying the Agilent L4450A LXI Instrument web interface. The address bar shows the URL http://192.168.1.221/. The page title is "Current Configuration of L4450A LXI Module". A "Modify Configuration" button is visible above a table of settings.

Parameter	Currently in use
DHCP:	ON
Automatic IP:	ON
IP Address:	192.168.1.221
Subnet Mask:	255.255.255.0
Default Gateway:	192.168.1.1
DHCP Server:	192.168.1.1
DNS Server:	192.168.1.1

Figure 2-7 Viewing LAN Configuration Settings from the Web Interface.

Clicking 'Modify Configuration' opens the window shown in [Figure 2-8](#) which allows you to edit the parameters shown.

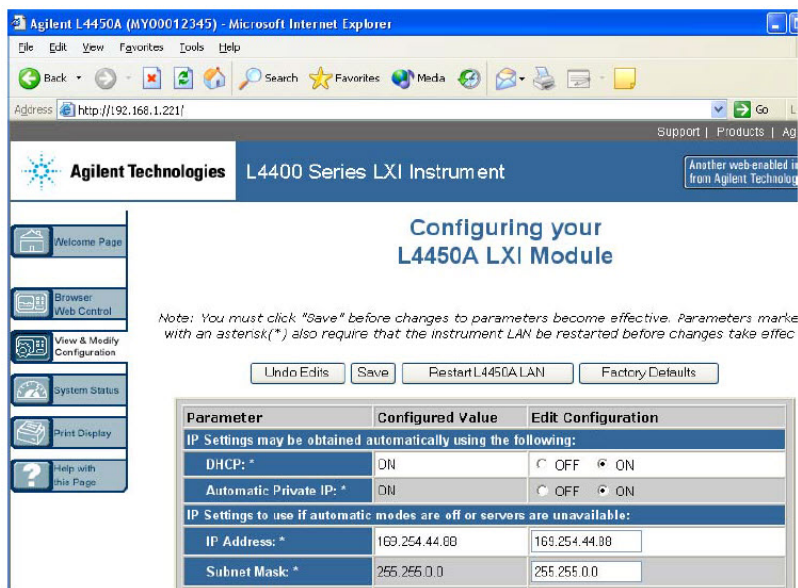

Figure 2-8 Changing the Instrument LAN Interface Configuration.

NOTE

Selecting “Help with this Page” on any Web interface window provides information on the use of the current Web interface page. Selecting “Help with this Page” on the “Browser Web Control” page provides a listing of the help contents

LAN Configuration Command Summary

In addition to using the Web interface, the instrument’s LAN configuration can be set/changed programmatically. Chapter 3, [Table 3-3](#) provides a listing of the LAN configuration commands implemented by the L4400 series instruments.

Refer to the L4400 Programmers Reference at www.keysight.com/find/L4400.

GPIB Configuration

NOTE

The following information assumes the GPIB interface card has been installed in your computer. If necessary, install the card as instructed by the documentation provided with the card.

The L4400 series instruments are available with an optional GPIB interface. The steps required to configure L4400 instruments for use over GPIB include:

- connecting the GPIB cables
- adding the instrument to the GPIB interface configuration (using Keysight Connection Expert)
- changing the instrument GPIB address (systems with multiple L4400 instruments)
- testing the IO path

Each L4400 series instrument is shipped from the factory with a default GPIB address of 9. Because instruments on the GPIB bus must have unique addresses, the L4400 instruments must be turned on one at a time, and the GPIB address changed before the next instrument is turned on and added to the configuration.

Connecting the GPIB Cables

GPIB cables can be connected in a “star” (all cables connect directly to the computer) or “linear” (instrument to instrument) configuration.

For systems with multiple L4400 series instruments, turn on only one L4400 instrument at this time. If there is another instrument on the bus at GPIB address 9 (i.e. 34980A), turn off that instrument until the address of the current L4400 instrument is changed.

Configuring the GPIB Interface

- 1** Launch **Keysight Connection Expert** from the Start menu or the Start Screen (Windows 8).
- 2** Select **+Add** on the **Keysight Connection Expert** toolbar.
- 3** Select **GPIB instrument**.
- 4** The **Add a GPIB instrument** dialog box is shown in [Figure 2-9](#).

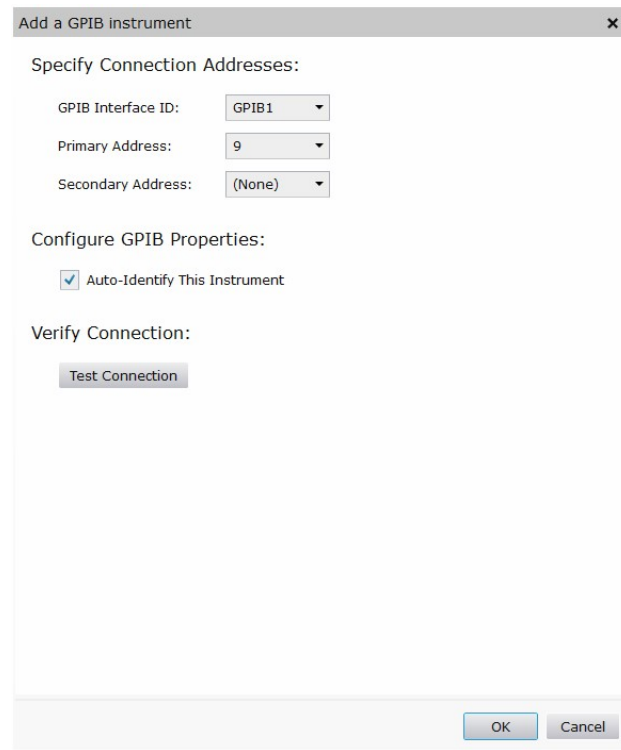

Figure 2-9 Remote GPIB Instrument Dialog Box.

- 5 Select 9 for **Primary Address**. This is the factory default address that will be changed as necessary in the following steps.
- 6 Select **Test connection** to verify the connectivity and configuration of the GPIB interface.

Verifying the GPIB Path

In the Keysight Connection Expert window, select and open 'Interactive IO'. Verify communication to the instrument by sending the `*IDN?` command using Send & Read below the command line.

The GPIB Address String

When programming the L4400 instruments over GPIB, the instrument's GPIB address is included in the address string. For example:

```
GPIB0::9::INSTR
```

Changing the GPIB Address

If you have only one L4400 instrument on the GPIB interface and there are no other instruments on the bus, the L4400 instrument address can remain set to 9. If you have multiple L4400 instruments or there is another GPIB instrument at address 9, then one of the addresses must be changed.

The command used to set the GPIB address on all L4400 instruments is:

```
SYSTem:COMMunication:GPIB:ADDRess < address >
```

The command can be abbreviated by including only the upper-case letters in the command syntax. The Interactive IO window is used to set the GPIB address in [Figure 2-10](#). In this example, the GPIB address is set to 10.

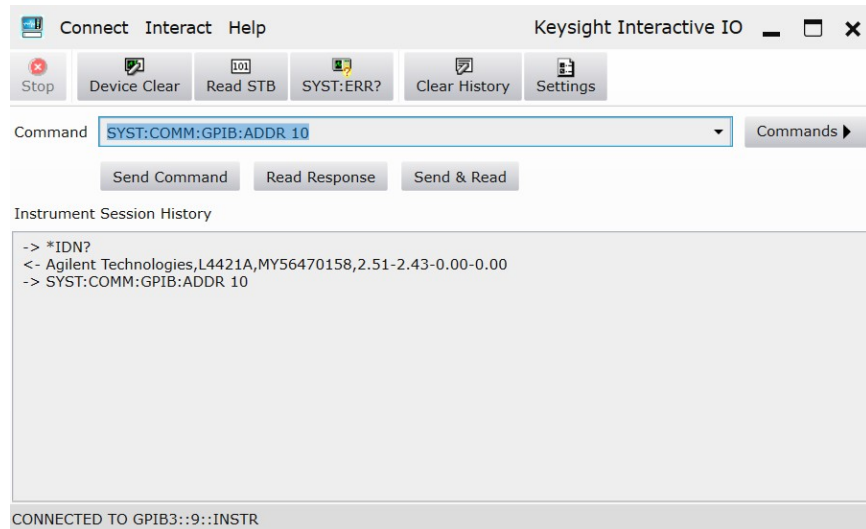



Figure 2-10 Setting the GPIB Address Using the Interactive IO Window.

Once the address is changed within the instrument, the address must also be changed in the Keysight Connection Expert.

From the Keysight Connection Expert, Remove the instrument, then select

Rescan All  to auto discover the instrument or Add New Instruments/Interfaces and GPIB instrument to add a new instrument at the new address.

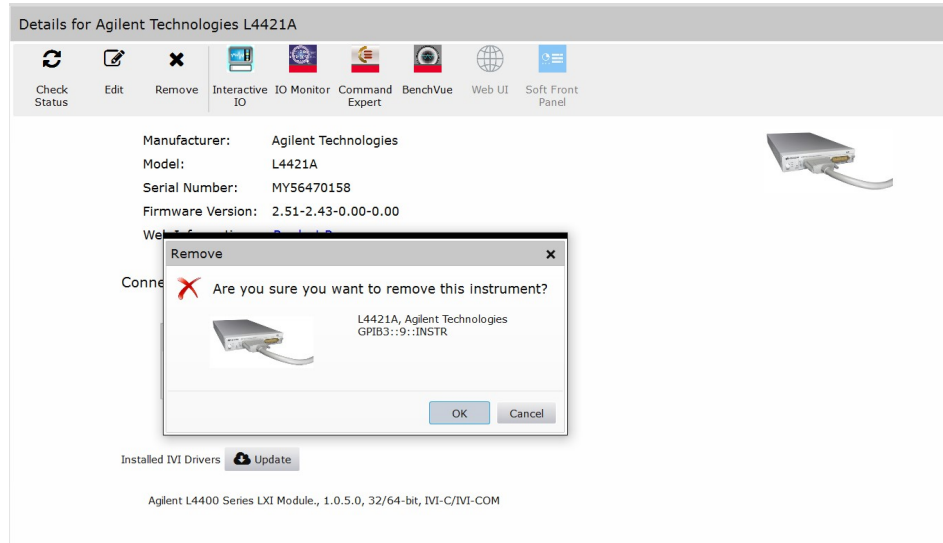

Figure 2-11 Removing instrument in Keysight Connection Expert.

Verifying the new GPIB Path

To verify the GPIB address change, you can close the Interactive IO window, select the instrument, and reopen Interactive IO. Or, with Interactive IO remaining open, select 'Connect' and change the address from '9' to '10'. Once connected to GPIB address '10', you can send the `*IDN?` command and verify the response from the instrument.

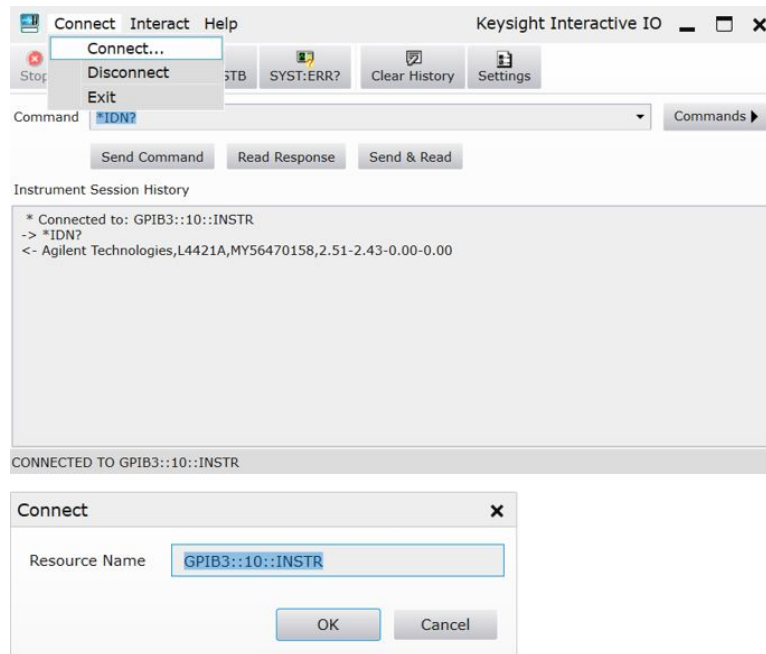

Figure 2-12 Connecting to GPIB Address 10 using Interactive IO.

Adding Additional Instruments

Additional instruments are added to the GPIB configuration using the process described earlier. The steps are summarized as follows and assume the GPIB cable has been connected between the computer and the new instrument.

- 1 Turn on the “**next**” L4400 instrument. Do not turn on those instruments whose addresses are still set to the default address of ‘9’.
- 2 Follow the steps from **Configuring the GPIB Interface** to add the instrument.
- 3 Open the Keysight Connection Expert “Interactive IO” window. Change the instrument’s GPIB address using the command:

```
SYSTem:COMMunication:GPIB:ADDRESS < address >
```
- 4 Change the address in the Keysight Connection Expert by removing the instrument (Figure 2-11) and add the instrument at the new address.
- 5 Verify the communication path to the new address.

Firmware Updates

Firmware updates for the L4400 series instruments consist of updates to the instrument carrier firmware, and if necessary, an update of the instrument module firmware. The updates are made available via the Web. The latest firmware updates are available from the Keysight 34980A product page at www.keysight.com/find/L4400.

Instrument Power-On and Default LAN Configuration States

The L4400 series instruments covered in this user's guide are set to their power on and preset states using any one the following commands:

*RST

SYSTem:CPON 1

SYSTem:PRESet

Table 2-2 lists the power-on and preset states for each instrument.

Table 2-2 L4400 Instrument Power-on and Preset States.

L4400 Series Instrument	Power-on Preset States
L4421A 40-Channel Armature Multiplexer	All channels open
L4433A Dual/Quad 4x8 Reed Matrix	All channels open 2-wire/1-wire mode: no change
L4437A 32-Channel Form A/ Form C General Purpose Switch	All channels open
L4445A Microwave Switch / Attenuator Driver	Channel drives enabled = userdefined defaults
L4450A 64-Bit Digital I/O w/Memory and Counter	I/O ports = Input Count = 0 Trace memory = cleared
L4451A 4-Channel Isolated D/A Converter w/Memory	DACs = 0Vdc Trace wavforms = cleared
L4452A Multifunction with Digital I/O, D/A, Totalizer	DIO Ports = Input Count = 0 DACs = 0Vdc

LAN Reset (Default) Configuration

Pressing the “LAN Reset” button (recessed) on the L4400 instrument front or rear panel restores the instrument's default LAN configuration. Table 2-3 lists the default LAN configuration settings.

Table 2-3 Default LAN Configuration Settings.

L4400 Series Instrument	Power-on Preset States
DHCP	ON
Automatic IP Addressing	ON
IP Settings if DHCP Server Unavailable	IP Address: 169.254.44.88 (default) Subnet Mask: 255.255.0.0 Default Gateway: 0.0.0.0
DNS Server	0.0.0.0 (may be assigned by the DHCP server)
Host Name (registered with DDNS if available)	A-product number-last 5 digits of serial number
LAN Keep Alive	1800 (seconds)
Ethernet Connection Monitoring	ON - instrument monitors its LAN connection; will attempt to automatically reconnect if disconnected from network.

3 Operating and Programming

L4400 Instrument Front Panel Overview	74
L4400 Instrument Rear Panel Overview	76
L4400 Series Channel Addressing Scheme	79
Introduction to the SCPI Command Language	80
L4400 SCPI Command Summary	84
L4400 Series Programming Examples	88
Analog Bus Applications	95
User-Defined Channel Labels	100
Scanning Applications	101
Scanning with External Instruments	115
Alarm Limits	118
Using Sequences	124
Instrument State Storage	132
Error Conditions	133
Relay Cycle Count	134
Calibration Overview	135

This chapter contains general operating and programming information applicable to multiple L4400 series instruments.

L4400 Instrument Front Panel Overview

LXI instruments within the L4400 family consist of the instrument carrier, an instrument sub-assembly, and if applicable, a wiring terminal block. The front panel of an L4400 instrument is shown in [Figure 3-1](#).

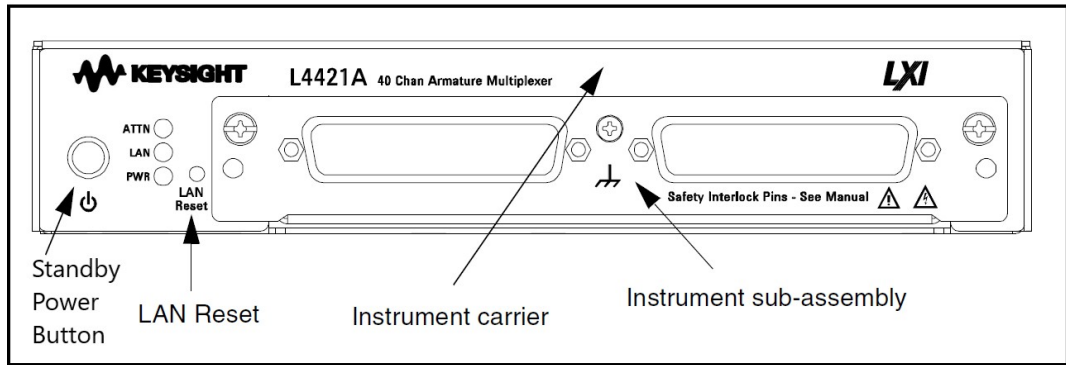

Figure 3-1 L4400 Instrument Front Panel (L4421A shown).

The only time it is necessary to remove the instrument sub-assembly from the carrier is to attach a support sleeve to those sub-assemblies that use a wiring terminal block.

[Chapter 1](#) contains information for removing the sub-assembly from the carrier and attaching the sleeve.

The LAN Reset Button

The LAN reset button allows you to reset the instrument’s LAN configuration to its default state. Refer to “[LAN Reset \(Default\) Configuration](#)” in [Chapter 2](#) for a listing of the default settings.

The Front Panel LEDs

The front panel LEDs:

- ATTN
- LAN

PWR

provide information on the status of the instrument. Table 3-1 lists the instrument’s status conditions based on the color and functioning of the LEDs.

Table 3-1 L4400 LED Definitions and Instrument Status.

LED	Color	Condition
ATTN	Off	Instrument is not turned on, and may or may not be connected to line power.
LAN	Off	
PWR	Off	
ATTN	flashing	Power-on/boot-up. ATTN and LAN will flash red and then green during the power-on self-test.
LAN	flashing	
PWR	Green	
ATTN	Off	LAN connection - instrument has an IP address
LAN	Green	
PWR	Green	
ATTN	Off	Instrument identification. Activated from instrument Web interface: - ON: Turn on Front Panel Interface Indicator - OFF: Turn off Front Panel Interface Indicator
LAN	Green (flashing)	
PWR	Green	
ATTN	Off	No LAN connection due to: - disconnected LAN cable - failure to acquire an IP address - waiting for DHCP-assigned address
LAN	Red	
PWR	Green	
ATTN	Red (flashing)	Instrument programming error or self-test error. Error queue is read using SYSTem:ERRor?
LAN	Green	
PWR	Green	
ATTN	Green (flashing)	Instrument Busy State - firmware download - lengthy instrument operation in progress
LAN	Green	
PWR	Green	

L4400 Instrument Rear Panel Overview

The rear panel of an L4400 series instrument is shown in [Figure 3-2](#). Note that the ports and connectors available are based on the instrument's options and functionality.

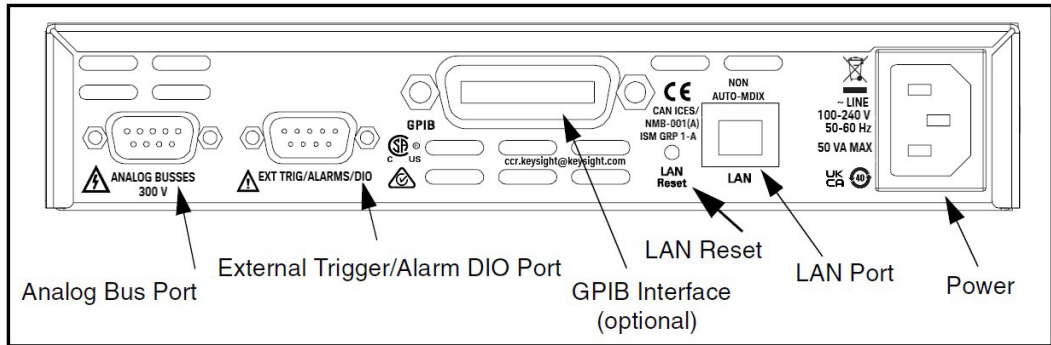

Figure 3-2 L4400 Instrument Rear Panel (L4421A shown).

Analog Bus Port

The Analog bus port, available on the rear panel of the L4421A 40-Channel Armature Multiplexer Module and the L4433A Dual/Quad 4x8 Reed Matrix Module, allows signals to be routed to external instruments such as digital multimeters (DMMs). There are four busses (ABUS1 - ABUS 4) on the port. [Figure 3-3](#) defines each bus and corresponding pin numbers.

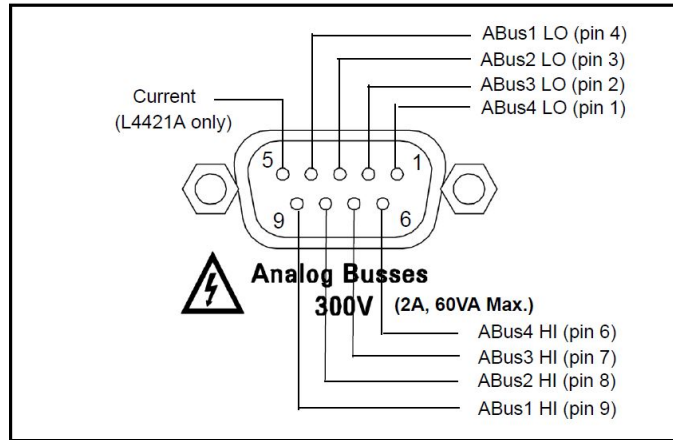

Figure 3-3 L4400 Analog Bus Port Pinouts.

See [Scanning with External Instruments](#) later in this chapter for information on how the analog bus is used for scanning a channel list with an external DMM.

Ext Trig/Alarms/DIO Port

The external trigger, alarms, and DIO port enables you to synchronize scanning between a switching instrument such as the L4421A and an external DMM. The port also allows you to output alarm signals to an external device or control system. [Figure 3-4](#) shows the pin out and signal definitions for the port.

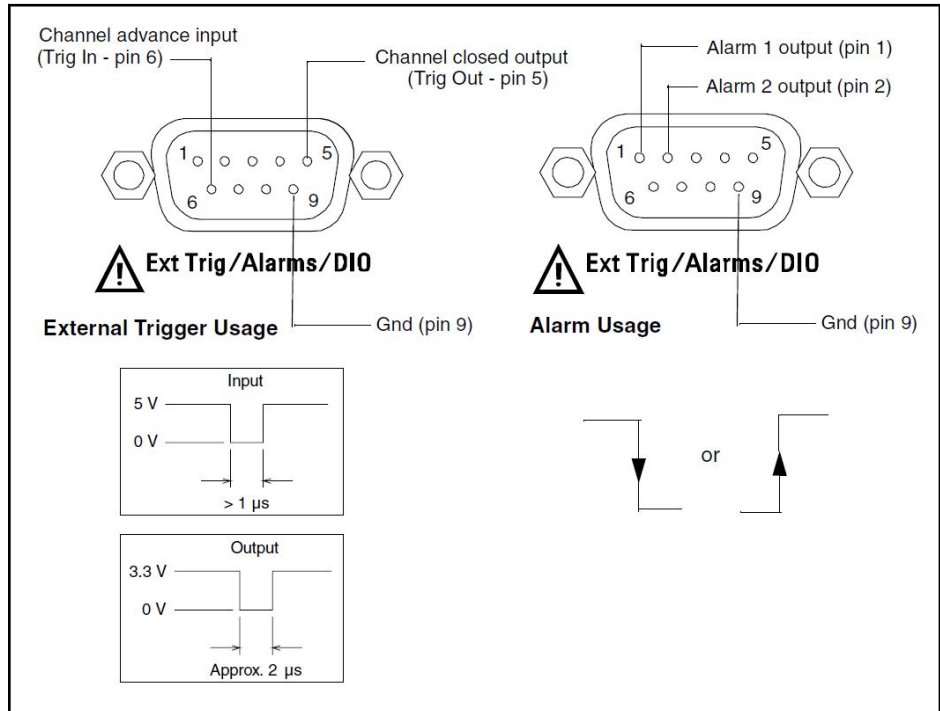

Figure 3-4 External Trigger and Alarm Port Pin Definitions.

GPIB Connector

The GPIB interface is available on all L4400 series instruments as Option-GPIB. This option must be purchased with the product. Products not ordered with the GPIB interface cannot be reconfigured to add it later.

LAN Port

The LAN port on the L4400 series instruments supports 10 Mbps and 100 Mbps data transfer rates (10BaseT/100BaseTx). The port is Non Auto-MDIX which means that the LAN crossover cable supplied with the instrument must be used when connecting the L4400 instrument directly (without a switch or router) to the computer. See [Connecting the LAN Cables](#) in Chapter 2 for more information.

L4400 Series Channel Addressing Scheme

The channel addressing scheme for the L4400 series LXI instruments uses the form 1ccc where ccc is the three-digit channel number. Following are examples of the scheme. Refer to the individual instrument chapters for more information on channel numbering.

Table 3-2 L4400 Series Channel Addressing Examples.

Channel Number	Definition
1014	Channel 14 on Bank 1 of the L4421A multiplexer module.
1921	Channel 921 (analog bus relay for ABUS 1) on Bank 2 of the L4421A multiplexer module or on Matrix 2 of the L4433A matrix module.
1304	Row 3 / column 4 on Matrix 1 of the L4433A matrix module (2-wire mode).
1437	Row 3 / column 7 on Matrix 4 of the L4433A matrix module (1-wire mode).
1201	Channel 201 on Bank 2 of the L4450A digital I/O module.

Introduction to the SCPI Command Language

The functions of the L4400 series instruments are programmed using SCPI (Standard Commands for Programmable Instruments) commands. The L4400 Programmer's Reference located at www.keysight.com/find/L4400, contains a complete description of each instrument's command set.

SCPI is an ASCII-based instrument command language designed for test and measurement instruments. SCPI commands use a hierarchical structure, also known as a tree system. In this system, associated commands are grouped together under a common node or root, thus forming subsystems. A portion of the ROUTe subsystem is shown below to illustrate the tree system.

```
ROUTE
:MONitor
[:CHANnel]:ENABle <mode>, (@<ch_list>)
[:CHANnel]:ENABle? (@<ch_list>)
```

ROUTE is the root keyword of the command, MONitor is a second-level keywords, CHANnel is a third-level keyword, and so on. A colon (:) separates a command keyword from a lower-level keyword.

Syntax Conventions

The SCPI syntax convention can be defined using the command shown below:

```
ROUTE:CHANnel:DRIVe:PULSe:WIDTh {<seconds>|MIN|MAX|DEF}, (@<ch_list>)
```

Keywords

The command syntax shows that most commands (and some parameters) are a mixture of upper- and lower-case letters. The upper-case letters indicate the abbreviated spelling for the command. For shorter program lines, you can send the abbreviated form. For better program readability, you can send the long form.

For example, in the above syntax statement DRIV and DRIVE are both acceptable forms. You can also use a combination of upper- and lower-case letters. When sending a command, the abbreviated form or the complete spelling of the command must be used. Any other combination will generate a syntax error.

Braces and Vertical Bars

Braces ({ }) enclose the parameter choices for a given command string. The braces are not sent with the command string.

A vertical bar (|) separates multiple parameter choices for a given command string.

Brackets

Triangle brackets (< >) indicate that you must specify a value for the enclosed parameter. For example, the syntax statement shows the <seconds> parameter enclosed in triangle brackets. The brackets are not sent with the command string. You must specify a value for the parameter.

Optional Parameters

Some parameters are enclosed in square brackets ([]). This indicates that the parameter is optional and can be omitted. The brackets are not sent with the command string. If you do not specify a value for an optional parameter, the instrument chooses a default value.

Command Separators

A colon (:) is used to separate a command keyword from a lower-level keyword. A blank space separates the keyword from the first parameter. If a command has more than one parameter, the subsequent parameters are separated by commas as shown below:

```
ROUT:CHAN:DRIV:PULS:WIDTH 0.010, (@1201,1202)
```

Linking Commands

A semicolon (;) is used to separate IEEE-448.2 common commands and commands at the same “node” within the same subsystem. For example:

```
*RST; *CLS; *IDN?;
```

Also, sending the following command string:

```
COUN:GAT:POL NORM(@1301);SOUR EXT, (@1301)
```

is the same as sending the following two commands:

```
[SENSe:]COUNter:GATe:POLarity NORM(@1301)
```

```
[SENSe:]COUNter:GATe:SOURce EXT, (@1301)
```

This can occur since "POLarity" and "SOURce" are at the same node within the [SENSe:]COUNter:GATe command.

A colon and a semicolon are used to link commands from different subsystems as shown below:

```
INP:IMP AUTO;:ROUT:CHAN:DEL 1
```

Using the MIN and MAX Parameters

For many commands, "MIN" or "MAX" can be used in place of a discrete parameter value. For example:

```
ROUT:CHAN:DRIV:PULS:WIDTH MIN, (@1201,1202)
```

sets the MINimum pulse width (0.001) available for the command.

Querying Parameter Settings

Many SCPI commands have a complimentary command that allows you to query the current value of the parameters. These commands are indicated by a '?' in the command syntax. For example:

```
ROUT:CHAN:DRIV:PULS:WIDTH? (@1201)
```

queries the pulse with setting for channel 1201.

Specifying Channel Lists and Scan Lists

A command's channel list (<ch_list>) or scan list (<scan_list>) parameter is used to specify a single channel, multiple channels, or a range of channels. The channel and scan lists must be preceded with the "@" symbol and must be enclosed in parentheses. The following commands demonstrate how the channel list parameter is used:

```
ROUT:CLOS (@1010) - close channel 10
```

```
ROUT:CLOS (@1010,1012,1015) - close channels 10, 12, and 15
```

```
ROUT:CLOS (@1005:1010,1015) - close channels 5-10, and 15
```

When specifying a range of channels, the first and last channels in the range must be valid. Any invalid channels within the range are ignored (no error is generated).

The Analog Bus relays (numbered 911, 912, 913, etc.) on the multiplexer and matrix modules are ignored if they are included in a range of channels. An error will be generated if an Analog Bus relay is specified as the first or last channel in a range of channels.

Refer to “[Scanning Applications](#)” later in this chapter for additional information creating/using a scan list.

L4400 SCPI Command Summary

Table 3-3 lists the SCPI commands that apply to all L4400 series instruments. The SCPI commands unique to each instrument are summarized in the instrument-specific chapters that follow Chapter 3.

For complete information on all commands, refer to www.keysight.com/find/L4400.

Table 3-3 L4400 Series SCPI Command Summary

Subsystem	Definition
STATus	*CLS
	*ESE <enable_value>
	*ESE?
	*ESR?
	*SRE <enable_value>
	*SRE?
	*STB?
	STATus:MODule:ENABle <enable_value>
	STATus:MODule:ENABle?
	STATus:MODule:EVENT?
	STATus:MODule:SLOT1:CONDition?
	STATus:MODule:SLOT1:ENABle <enable_value>
	STATus:MODule:SLOT1:ENABle?
	STATus:MODule:SLOT1:EVENT?
	STATus:OPERation:CONDition?
	STATus:OPERation:ENABle <enable_value>
	STATus:OPERation:ENABle?
	STATus:OPERation[:EVENT]?
	STATus:PRESet
	STATus:QUEStionable:CONDition?
	STATus:QUEStionable:ENABle <enable_value>
	STATus:QUEStionable:ENABle?
	STATus:QUEStionable[:EVENT]?
	SYSTem:MODule?

Subsystem	Definition
<p style="text-align: center;">MEMory (State Storage)</p>	<p>*RCL {1 2 3 4 5} *SAV {1 2 3 4 5} MEMory:NSTates? MEMory:STATE:CATalog? MEMory:STATE:DELeTe {1 2 3 4 5} MEMory:STATE:DELeTe:ALL MEMory:STATE:NAME {1 2 3 4 5} [, <name>] MEMory:STATE:NAME? {1 2 3 4 5} MEMory:STATE:RECall:AUTO {OFF 0 ON 1} MEMory:STATE:RECall:AUTO? MEMory:STATE:RECall:SElect {1 2 3 4 5} MEMory:STATE:RECall:SElect? MEMory:STATE:VALid? {1 2 3 4 5}</p>
<p style="text-align: center;">IEEE-488 Commands</p>	<p>*CLS *ESE <enable_value> *ESE? *ESR? *IDN? *OPC *OPC? *RCL {1 2 3 4 5} *RST *SAV {1 2 3 4 5} *SRE <enable_value> *SRE? *STB? *TRG *TST? *WAI</p>

Subsystem	Definition
	*IDN? *RST *TST SYSTem:CDEscription[:LONG]? 1 SYSTem:CDEscription:SHORT? 1 SYSTem:COMMunicate:ENABLE {OFF 0 ON 1},{GPIB LAN SOCKets TELNet VXI11 WEB} SYSTem:COMMunicate:ENABLE? {GPIB LAN SOCKets TELNet VXI11 WEB} SYSTem:COMMunicate:GPIB:ADDRes <address> SYSTem:COMMunicate:GPIB:ADDRes? SYSTem:COMMunicate:GPIB:ADDRes:INSTalled? SYSTem:CPON 1
SYSTem (System-Related Commands)	SYSTem:CTYPE? 1 SYSTem:DATE <yyyy>,<mm>,<dd> SYSTem:DATE? SYSTem:DElay[:IMMediate] <seconds> SYSTem:ERRor? SYSTem:LOCK:OWNer? SYSTem:LOCK:RELease SYSTem:LOCK:REQuest? SYSTem:MODule? SYSTem:PRESet SYSTem:SECurity:IMMediate SYSTem:TIME <hh>,<mm>,<ss.sss> SYSTem:TIME? SYSTem:VERSion?

Subsystem	Definition
<p style="text-align: center;">SYSTEM (LAN Configuration)</p>	SYSTem:COMMunicate:LAN:AUTOip {OFF 0 ON 1}
	SYSTem:COMMunicate:LAN:AUTOip?
	SYSTem:COMMunicate:LAN:BSTatus?
	SYSTem:COMMunicate:LAN:CONTRol?
	SYSTem:COMMunicate:LAN:DHCP {OFF 0 ON 1}
	SYSTem:COMMunicate:LAN:DHCP?
	SYSTem:COMMunicate:LAN:DNS "<address>"
	SYSTem:COMMunicate:LAN:DNS?
	SYSTem:COMMunicate:LAN:DOMain "<name>"
	SYSTem:COMMunicate:LAN:DOMain? [{{CURRENT STATIC}}
	SYSTem:COMMunicate:LAN:GATEway <address>
	SYSTem:COMMunicate:LAN:GATEway? [{{CURRENT STATIC}}
	SYSTem:COMMunicate:LAN:HISTory:CLEar
	SYSTem:COMMunicate:LAN:HISTory?
	SYSTem:COMMunicate:LAN:HOSTname "<name>"
	SYSTem:COMMunicate:LAN:HOSTname? [{{CURRENT STATIC}}
	SYSTem:COMMunicate:LAN:IPADdress "<address>"
	SYSTem:COMMunicate:LAN:IPADdress? [{{CURRENT STATIC}}
	SYSTem:COMMunicate:LAN:KEEPAlive {<seconds> MIN MAX}
	SYSTem:COMMunicate:LAN:KEEPAlive? [{{MIN MAX}}
	SYSTem:COMMunicate:LAN:MAC?
	SYSTem:COMMunicate:LAN:SMASK "<mask>"
	SYSTem:COMMunicate:LAN:SMASK? [{{CURRENT STATIC}}
	SYSTem:COMMunicate:LAN:TELNet:PROMpt "<string>"
	SYSTem:COMMunicate:LAN:TELNet:PROMpt?
	SYSTem:COMMunicate:LAN:TELNet:WMESsage "<string>"
	SYSTem:COMMunicate:LAN:TELNet:WMESsage?

L4400 Series Programming Examples

The L4400 series at www.keysight.com/find/L4400 contains programming examples to familiarize you with the operation of selected L4400 instruments. Once communication paths to the instruments have been set (Chapter 2), the examples can be used as an introduction to the sequence of commands necessary to program the functions available with the instruments.

The examples include multiple development environments and demonstrate instrument programming via drivers and direct programming through the I/O libraries. The drivers and I/O libraries used include:

- IVI-C
- IVI-COM
- VISA
- VISA COM

Once installed, the examples are located in the following (default) path and are grouped into development environment directories:

C:\Program Files\Keysight\L4400\Examples

To select a specific example, open the environment directory under “Examples” followed by the driver (IVI-COM, IVI-C) or IO library (VISA, VISA COM) subdirectory.

The examples assume that you are familiar with the programming languages demonstrated and the tools associated with the development environment. Note that before you run a programming example, the program must be edited to include the address string of your particular instrument. The following sections provide instructions for editing the programs based on the driver type and development environment.

Modifying IVI-COM Examples (.NET)

IVI-COM examples are available for the Microsoft C#.NET and Visual Basic.NET development environments. To modify IVI-COM (C#) examples for use with your instrument, open the example in the \IVI-COM subdirectory for your development environment by double-clicking the example name with the **.csproj** extension.

C#

Once the development environment opens, select the example source code file (.cs extension) of the same name. Locate the “Initialize” function and change the address string. Figure 3-5 shows where the address string is changed within the source code for program “MultifunctionExample.sln.

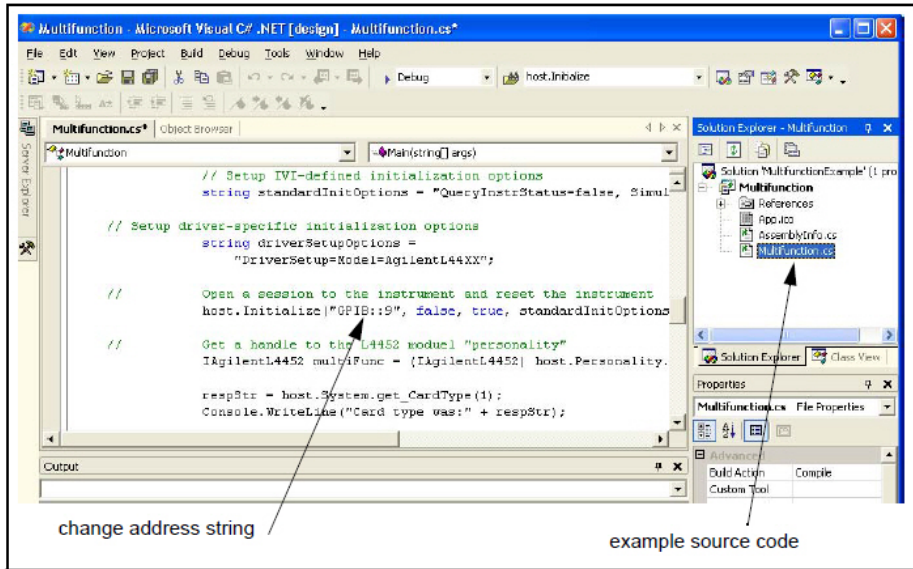

Figure 3-5 Changing the Instrument Address String (IVI-COM Programs).

Visual Basic.NET

When using the IVI-COM examples with Visual BASIC.NET, you are prompted to enter/change the instrument’s address string after starting the program.

To modify IVI-COM Visual Basic examples for use with your instrument, open the example in the \IVI-COM subdirectory for your development environment by double-clicking the example name with the .vbproj extension.

Figure 3-6 is an example of the window used during program execution to change the address string.

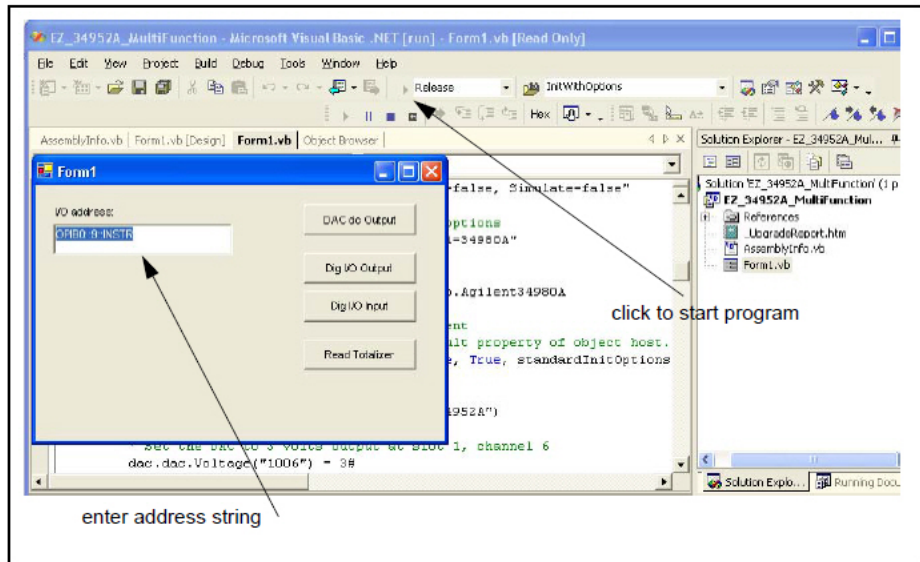

Figure 3-6 Changing the Address String (IVI-COM / Visual Basic.NET).

Visual Basic 6.0

To modify IVI-COM examples with Visual Basic 6.0, open the example by double-clicking the example name with the **.vbp** extension. When using Visual BASIC 6.0, you are prompted to enter/change the instrument's address string after starting the program.

The Visual Basic 6.0 form is similar to that shown in [Figure 3-6](#).

Modifying IVI-C Examples

IVI-C examples are available for the Microsoft Visual C++ 6.0 environment. To modify IVI-C examples for use with your instrument, open the example in the \IVI-C subdirectory of VC 60 by double-clicking the example name with the **.vcproj** extension. Once the development environment opens, select the example source code file (**.cpp** extension) of the same name.

Locate “InitWithOptions” and change the address string as shown in the example of Figure 3-7.

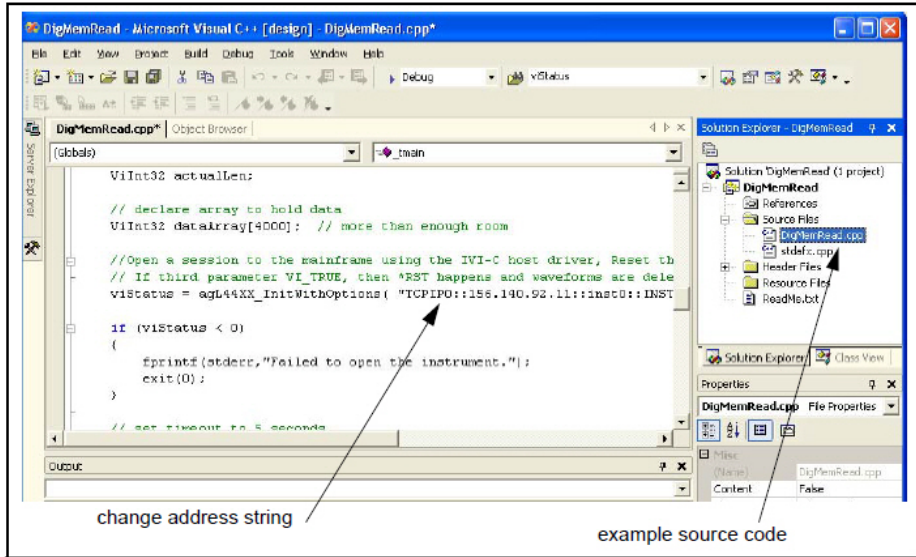

Figure 3-7 Changing the Instrument Address String (IVI-C Programs).

Modifying VISA and VISA COM Examples

Keysight VISA examples are available with the Microsoft Visual C++ 6.0 and Visual Basic 6.0 environments. To modify VISA examples for use with your instrument, open the example in the \VISA subdirectory of the development environment by double-clicking the example name with the `.dsp` extension. Once the development environment opens, select the example source code file (`.c` extension) of the same name.

Locate “DEFAULT_LOGICAL_ADDRESS” and change the address string as shown in the example of Figure 3-8.

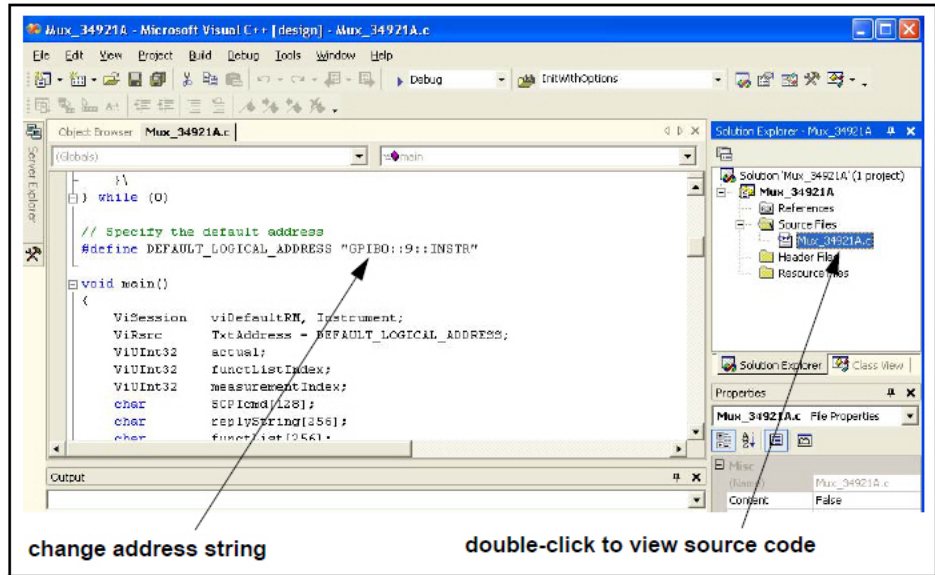

Figure 3-8 Changing the Instrument Address String (VISA Programs).

Visual Basic 6.0

To modify VISA examples with Visual Basic 6.0, open the example by double-clicking the example name with the **.vbp** extension. When using Visual BASIC 6.0, you are prompted to enter/change the instrument’s address string after starting the program.

The Visual Basic 6.0 form is similar to that shown in [Figure 3-6](#).

VISA COM Examples

VISA COM examples are available with the Microsoft Visual Basic 6.0 environment. To modify the examples, double-click the example name with the **.vbp** extension.

Once the Visual Basic environment opens, start the program using the “Start” arrow shown in [Figure 3-9](#). The program prompts you for the instrument address as shown.

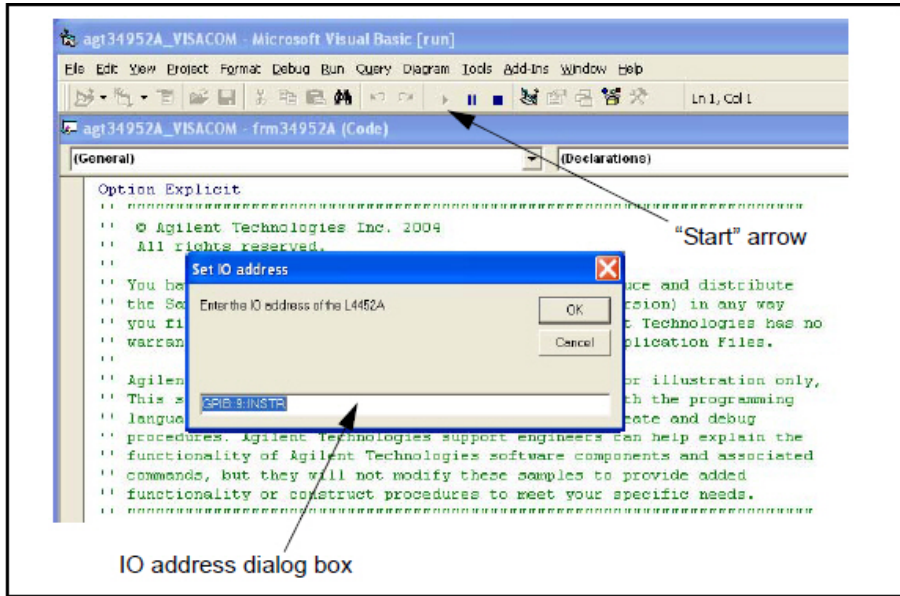

Figure 3-9 Changing the Address String (VISA COM Programs).

Using L4400 Instruments in Keysight 34980A Applications

The L4400 series LXI instruments have counterparts that are available as plug-in modules for the Keysight 34980A Multifunction Switch/Measure Unit. [Table 3-4](#) lists the L4400 series instruments and the corresponding 34980A products.

Table 3-4 Keysight L4400 Series and 34980A Module Cross Reference.

L4400A Instrument	34980A Plug-In Module
L4421A: 40-Channel Armature Multiplexer	34921A
L4433A: Dual/Quad 4x8 Reed Matrix	34933A
L4437A: General Purpose Switch	34937A
L4445A: Microwave Switch/Attenuator	34945A
L4450A: 64-Bit Digital I/O	34950A

L4400A Instrument	34980A Plug-In Module
L4451A: 4-Channel Isolated D/A Converter	34951A
L4452A: Multifunction Module	34952A

Because of the similarity in products, code and applications can be leveraged and ported between an L4400 instrument and its 34980A module counterpart.

Porting Applications

The programming examples at www.keysight.com/find/L4400 as well as all application programs contain a function that opens a “session” to, and initializes the instrument.

In addition to specifying the instrument’s address string, this initialization function contains parameters that query and reset the instrument when the session is opened. These parameters are represented by true/false conditions that either perform an ID query or reset (true) or do not (false).

By setting the ID query parameter of the (session) initialization function to ‘False’, the program can be ported between corresponding (L4400 and 34980A) instruments.

For example, in the IVI-COM programming example MultifunctionExample.csproj, the instrument session is opened using the function:

```

    address string ——— ID query
    host.Initialize("GPIB::9", false, true, standardInitOptions + "," +
    driverSetupOptions);
                                   reset
  
```

By setting the ID query parameter to ‘false’ as shown and changing the address string as required, the example can be run using the L4452A multifunction module or the 34952A multifunction module. Note that channel addresses within the program must be changed accordingly. See “[L4400 Series Channel Addressing Scheme](#)” for more information.

Modifying each of the programming examples in this manner allows the examples to be used by the L4400 instruments and their 34980A counterparts.

Analog Bus Applications

Usage:

- L4421A 40-Channel Armature Multiplexer
- L4433A Dual/Quad 4x8 Reed Matrix

This section provides important environmental and electrical considerations that can affect analog bus usage on the L4421A and L4433A.

Environmental Operating Conditions

The L4400 series instruments are designed to operate in a maximum relative humidity (non-condensing) of 80%RH up to 40°C and decreases linearly to 37%RH at 55°C*. Do not use in locations where conductive dust or electrolytic salt dust may be present.

The L4400 instruments should be operated in an indoor environment where temperature and humidity are controlled. Condensation can pose a potential shock hazard. Condensation can occur when the instrument is moved from a cold to a warm environment, or if the temperature and/or humidity of the environment changes quickly.

When used in pollution degree 1 conditions, the maximum voltage rating for the Analog Buses is 300V. When used in pollution degree 2 conditions, the maximum voltage rating is 100V. If conditions change, ensure that condensation has evaporated and the instrument has thermally stabilized until pollution degree 1 conditions are restored before turning on power to the equipment.

*From 40°C to 55°C, the maximum % Relative Humidity follows the line of constant dew point.

CAUTION

The instrument is designed for use in Installation Category II.

NOTE

Pollution Degree 1: No pollution or only dry, non-conductive pollution occurs. The pollution has no influence (on insulation).

NOTE

Pollution Degree 2: Normally only non-conductive pollution occurs. Occasionally, a temporary conductivity (leakage current between isolated conductors) caused by condensation can be expected.

Electrical Operating Conditions

WARNING

To avoid electric shock, turn off the L4400 instrument and disconnect or de-energize all field wiring to the modules and the Analog Bus connector before removing any module or slot cover. Never operate the instrument without the terminal block covers securely installed. Failure to do so may lead to hazardous voltage signals that may result in fire hazards or shock hazards that could result in personal injury or death.

Transients

The Analog Buses are designed to safely withstand occasional transient overvoltages up to 1000 V_{peak}. Typically, these transient overvoltages result from switching inductive loads or from nearby lightning strikes. The lightning-caused transient overvoltages that may occasionally occur on mains power outlets may be as high as 2500 V_{peak}.

WARNING

Do not connect the Analog Buses directly to a mains power outlet. If it is necessary to measure a mains voltage or any circuit where a large inductive load may be switched, you must add signal conditioning elements to reduce the potential transients before they reach the Analog Buses.

High Energy Sources

The Analog Buses are designed to handle inputs up to their rated currents or their rated powers, whichever is less. Under certain fault conditions, high energy sources could provide substantially more current or power than the instrument can handle. It is important to provide external current limiting, such as fuses, if the inputs are connected to high-energy sources.

WARNING

Ensure that the current limiting devices / snubber circuits are appropriate for the signal being tested. Failure to do so may result in hazardous conditions such as fire or shock and could lead to personal injury or death.

WARNING

Keysight Customers utilizing the Open Platform Test systems are classified as follows and require the users to have the appropriate skillset:

Operator: Interacts with the test system in a production environment, selection of test sequences, defining variables, running tests (test results, test statistics, control of marking devices)

Supervisor: includes access to maintenance functions and utility sequences (control of handline system functions, access to test parameters and limits)

Developer: Full access

WARNING

L4421A - ABUS3 and ABUS4 and closing multiple channels are for Supervisors and Developers use only. Do not perform these procedures unless qualified to do so. Failure to recognize and observe normal safety precautions could result in personal injury or death.

WARNING

L4421A - When working with dangerous voltage levels, intentional closing of multiple bus and channel relays could cause a potentially lethal hazard on external connections. Use extreme caution when handling and testing and adjusting this instrument. To prevent electrical shock capable of causing injury or death, never handle the instrument when any power is applied to it. Discharge all circuits and ensure no hazardous voltage remains on any accessible part of the test system.

WARNING

L4421A - Dangerous voltage levels $\pm 300V$, capable of causing injury or death, may be present on a channel connected to external circuits. Use extreme caution when handling and testing and adjusting this instrument.

WARNING

Any voltages greater than 30 Vrms, 42.4 Vpeak and 60 Vdc are considered hazardous voltage (IEC 61010-1).

CAUTION

Install current limiting devices between high energy sources and the module inputs.

Safety Interlock

The Safety Interlock feature prevents connections to the Analog Buses if no terminal block or properly-wired cable is connected to the L4421A or L4433A.

Normally, if you attempt to connect to the Analog Buses without a terminal block or properly-wired cable connected, an error is generated. You can, however, temporarily disable errors generated by the Safety Interlock feature. This simulation mode may be useful during test system development when you may not have connected any terminal blocks or cables to your module.

CAUTION

The Safety Interlock feature is implemented in hardware on the modules and cannot be circumvented. Regardless of whether the simulation mode is enabled or disabled, all Analog Bus operations are prohibited as long as no terminal block or properly-wired cable is connected to the module.

- When the simulation mode is enabled, the Analog Bus relays will appear to close and open as directed. For example, no errors are generated if you close an Analog Bus relay from the remote interface or Web Interface. However, remember that the Safety Interlock feature prevents the actual hardware state of the Analog Bus relays from being changed. When you connect a terminal

block or cable to the module, the Analog Bus relays will open and close normally.

- The simulation setting is stored in volatile memory and will be lost when power is turned off. To re-enable the simulation mode after power has been off, you must send the command again. The command used is:

```
SYSTem:ABUS:INTerlock:SIMulate {OFF|ON}
```

User-Defined Channel Labels

Usage:

- All L4400 series instruments
- You can assign user-defined labels to any channel, including Analog Bus channels on the L4421A and L4433A instruments. User-defined channel labels are available for identification purposes only and cannot be used in place of a channel number within a command string.
- When shipped from the factory, each channel is assigned a unique factory-default label (cannot be overwritten). From the instruments' Web interfaces, the factory-default labels are displayed as the channel number (e.g., "1001", "1020", etc.).
- If desired, you can assign the same user-defined label to multiple channels within the same module or on different modules (i.e., channel labels are not required to be unique).
- You can specify a label with up to 18 characters. You can use letters (A-Z), numbers (0-9), and the underscore character. If you specify a label with more than the allowed 18 characters, it will be truncated (no error is generated).
- From the Web Interface, a limited number of characters can be displayed due to space constraints in the browser window. If the user-defined label is too long to be displayed properly, it will be truncated (no error is generated).
- All user-defined channel labels are stored in non-volatile memory, and do not change when power has been off, after a Factory Reset (*RST command), after an Instrument Preset (SYSTEM:PRESet command), or after a stored state is recalled (*RCL command).

The following command assigns a label ("TEST_PT_1") to channel 3 in slot 1.

```
ROUT:CHAN:LABEL "TEST_PT_1",(@1003)
```

The following command clears the user-defined label previously assigned to channel 3 in slot 1. The channel will now be identified by its factory default label (e.g., "MUX CH BANK 1", "MATRIX1 ROW3 COL4", "DIO BYTE 1", etc.).

```
ROUT:CHAN:LABEL "",(@1003)
```

The following command clears all user-defined channel labels on the instrument and restores the factory-default labels.

```
ROUT:CHAN:LABEL:CLEAR:MOD 1
```

Scanning Applications

Usage:

- L4421A 40-Channel Armature Multiplexer
- L4450A 64-Bit Digital I/O (digital input, counter channels only)
- L4452A Multifunction Module (digital input, totalizer channels only)

Channels on selected L4400 series instruments can be “scanned” by separate devices such as a DMM. During a scan, the instrument channels are connected to the device and a measurement/reading is made one channel at a time. Once the measurement is complete, the scan advances to the next channel in the list until the end of the scan list is reached and the number of passes (sweeps) through the scan list is complete.

For scanning applications involving the L4421A and a DMM, readings are stored on the DMM. For applications involving scans of the digital input and counter channels of the L4450A and the digital input and totalizer channels of the L4452A, readings are stored in L4450A/L4452A memory.

Scanning is not allowed with the other (L4433A, L4437A, L4445A) switching instruments. Also, scan lists cannot include digital output channels or DAC voltage channels.

Rules for Scanning

- Before you can initiate a scan, you must set up a scan list to include all desired multiplexer or digital channels. Channels which are not in the scan list are skipped during the scan. By default, channels are scanned in ascending order. If your application requires non-ordered scanning of the channels in the present scan list, see “[Non-Sequential Scanning](#)” on page 112.
- You can store at least 500,000 scan readings in instrument (L4450A/L4452A) memory and all readings are automatically time stamped. If memory overflows, a status register bit is set and new readings will overwrite the first (oldest) readings stored. The most recent readings are always preserved. Using the `DATA:REMOve?` or `R?` command to retrieve readings during a scan REMOVES the readings from memory. Using `FETCh?` after the scan completes retrieves the readings and the readings also remain in instrument memory.

- Each time you start a new scan, the instrument clears all readings (including alarm data) stored in reading memory from the previous scan. Therefore, the contents of memory are always from the most recent scan.
- The Analog Bus relays are automatically opened and closed as required during the scan to place the signal on the analog bus. For example, with the L4421A, all 2-wire measurements use the ABus1 (MEAS) relays; for 4-wire measurements, the ABus2 (SENS) relays are used in addition to the ABus1 relays.
- When the scan is initiated, the instrument will open all channels in banks that contain one or more channels in the scan list.
- In order to guarantee that no signals are connected to the Analog Buses prior to the scan, the instrument will open all ABus1 relays (applies to all banks in all slots). In banks that contain channels in the scan list, the instrument will also open all ABus2 relays (regardless of whether 4-wire measurements are involved). If no channels configured for 4-wire measurements are included in the scan list, the state of the ABus2 relays in the non-scanned banks is not altered.
- The state of the ABus3 and ABus4 relays is not altered and these relays remain available for use during the scan. However, be sure to use CAUTION when closing these relays on banks involved in the scan. While the scan is running, any signals present on ABus3 and/or ABus4 will be joined with the scanned measurement on ABus1 and ABus2.
- While the scan is running, the instrument prevents use of all channels in banks that contain one or more channels in the specified scan list (these channels are dedicated to the scan). In addition, the instrument prevents use of all ABus1 and ABus2 relays on banks containing channels in the scan list. If one or more channels configured for 4-wire measurements are included in the scan list, then the rules for ABus2 relay operations are extended to the non-scanned banks as well.
- If the ABus1 relay used for current measurements (channel 931 on L4421A only) is not closed prior to the initiation of the scan, the four current channels (channels 41 through 44) are not affected by the scan. However, if the ABus1 relay is closed, the instrument will open the ABus1 relay as well as the four associated current channels in a make-before-break fashion.
- When you add a digital read (digital modules) to a scan list, the corresponding channel is dedicated to the scan. The instrument issues a Card Reset to make that channel an input channel (the other channel is not affected).

- While the scan is running, you can perform low-level control operations on any channels on the digital modules that are not in the scan. For example, you can output a DAC voltage or write to a digital channel (even if the totalizer is part of the scan list). However, you cannot change any parameters that affect the scan (channel configuration, scan interval, Card Reset, etc.) while a scan is running.
- If a scan includes a read of the totalizer, the count is reset each time it is read during the scan only when the totalizer reset mode is enabled.
- At the end of the scan, the last channel that was scanned will be opened (as well as any Analog Bus relays used during the scan). Any channels that were opened during the scan will remain open at the completion of the scan.
- If you abort a scan that is running, the instrument will terminate any reading in progress (readings are not cleared from memory). If a scan is in progress when the command is received, the scan will not be completed and you cannot resume the scan from where it left off. Note that if you initiate a new scan, all readings are cleared from memory.
- The Monitor mode is automatically enabled on all channels that are part of the active scan list (see “**Monitor Mode**” on page 113).
- The present scan list is stored in volatile memory and will be lost when power is turned off or after a Factory Reset (*RST command).

Creating the Scan List

Usage:

- L4421A 40-Channel Armature Multiplexer
- L4450A 64-Bit Digital I/O (digital input, counter channels only)
- L4452A Multifunction Module (digital input, totalizer channels only)

A scan list is created as follows:

- Use the `ROUTE:SCAN` command to define the list of channels in the scan list. To determine what channels are currently in the scan list, use the `ROUTE:SCAN?` query command.
- To add channels to the present scan list, use the `ROUTE:SCAN:ADD` command. To remove channels from the present scan list, use the `ROUTE:SCAN:REMove` command.

- To remove all channels from the scan list, send “**ROUT:SCAN (@)**”.
- To initiate a scan, use the **INITiate** or **READ?** command. Each time you initiate a new scan, the instrument will clear the previous set of readings from memory.
- To stop a scan in progress, use the **ABORT** command.

Scan Trigger Source

Usage:

- L4421A 40-Channel Armature Multiplexer
- L4450A 64-Bit Digital I/O (digital input, counter channels only)
- L4452A Multifunction Module (digital input, totalizer channels only)

You can configure the event or action that controls the onset of each sweep through the scan list (a sweep is one pass through the scan list):

- You can set the instrument’s internal timer to automatically scan at a specific interval. You can also program a time delay between channels in the scan list (see “**Channel Delay**” on page 111).
- You can start a scan when an external TTL trigger pulse is received.
- You can start a scan when an alarm event (L4450A, L4452A) is logged on the channel being monitored.

Interval Scanning

In this configuration, you control the frequency of scan sweeps by selecting a wait period from the start of one trigger to the start of the next trigger (called the trigger-to-trigger interval). If the scan interval is less than the time required to measure all channels in the scan list, the instrument will scan continuously, as fast as possible (no error is generated).

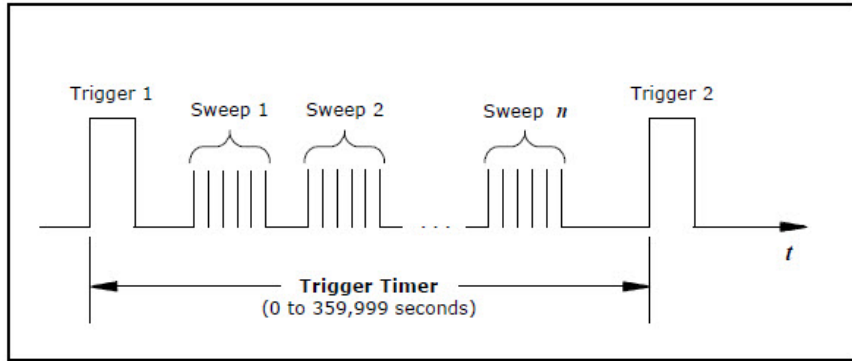

Figure 3-10 Trigger-to-Trigger Interval.

- You can set the scan interval to any value between 0 seconds and 99:59:59 hours (359,999 seconds), with 1 ms resolution.
- Once you have initiated the scan, the instrument will continue scanning until you stop it or until the trigger count is reached. See “Trigger Count” on page 109 for more information.
- Mx+B scaling and alarm limits (L4450A, L4452A) are applied to measurements during a scan and all data is stored in volatile memory.
- The `CONFigure` and `MEASure?` commands (L4450A, L4452A) automatically set the scan interval to immediate (0 seconds) and the scan count to 1 sweep.
- The instrument sets the scan interval to immediate (0 seconds) after a Factory Reset (`*RST` command). An Instrument Preset (`SYSTem:PRESet` command) or Card Reset (`SYSTem:CPON` command) does not change the setting.

The following program segment configures the instrument for an interval scan.

<code>TRIG:SOURCE TIMER</code>	Select interval time mode
<code>TRIG:TIMER 5</code>	Set the scan interval to 5 seconds
<code>TRIG:COUNT 2</code>	Sweep the scan list 2 times
<code>INIT</code>	Initiate the scan

NOTE

To stop a scan, send the **ABORt** command.

Manual Scanning

In this configuration, the instrument waits for a command before sweeping through the scan list.

- All readings from the scan are stored in volatile memory. Readings accumulate in memory until the scan is terminated (until the trigger count is reached or until you abort the scan).
- You can specify a trigger count which sets the number of scan trigger commands that will be accepted before terminating the scan. See “**Trigger Count**” on page 109 for more information.
- Mx+B scaling and alarm limits (L4450A, L4452A) are applied to measurements during a manual scanning operation and all data is stored in volatile memory.

The following program segment configures the instrument for a manual scanning operation.

```
TRIG:SOURCE BUS           Select bus (manual) mode
TRIG:COUNT 2            Sweep the scan list 2 times
INIT                     Initiate the scan
```

Then, send the ***TRG** (trigger) command to begin each scan sweep.

NOTE

To stop a scan, send the **ABORt** command.

Scanning on Alarm

Usage:

- L4450A 64-Bit Digital I/O (counter channels only)

- L4452A Multifunction Module (totalizer channels only)

In this configuration, the instrument initiates a scan each time a reading crosses an alarm limit on a channel. You can also assign alarms to channels on the digital modules. For example, you can generate an alarm when a specific bit pattern or bit pattern change is detected on a digital input channel or when a specific count is reached on a totalizer channel.

NOTE

For complete details on configuring and using alarms, refer to **“Alarm Limits”** on page 118.

- In this scan configuration, you can use the Monitor function to continuously take readings on a selected channel and wait for an alarm on that channel. Channels do not have to be part of an active scan list to be monitored; however, the channel must be configured for a measurement in order to be monitored.
- All readings from the scan are stored in the instrument’s volatile memory. Readings accumulate in memory until the scan is terminated (until the trigger count is reached or until you abort the scan).
- You can specify a trigger count which sets the number of scan trigger commands that will be accepted before terminating the scan. See **“Trigger Count”** on page 109 for more information.
- Mx+B scaling and alarm limits are applied to measurements during a manual scanning operation and all data is stored in volatile memory.

The following program segment configures the instrument to continuously scan when an alarm is detected.

TRIG:SOURCE ALARM1	Select alarm configuration
TRIG:SOURCE:ALARM CONT	Select continuous scan mode
CALC:LIM:UPPER 10.25, (@1003)	Set upper alarm limit
CALC:LIM:UPPER:STATE ON, (@1003)	Enable alarms
OUTPUT:ALARM1:SOURCE (@1003)	Report alarms on Alarm 1

<code>ROUT:MON:CHAN (@1003)</code>	Select monitor channel
<code>ROUT:MON:CHAN:ENABLE ON, (@1003)</code>	Enable monitoring on channel
<code>ROUT:MON:STATE ON</code>	Enable monitor mode
<code>INIT</code>	Initiate the scan

NOTE

To stop a scan, send the **ABORT** command.

Externally Triggering a Scan

In this configuration, the instrument sweeps through the scan list once each time a low-going TTL pulse is received on the rear-panel Ext Trig Input line (pin 6).

- You can specify a scan count which sets the number of external pulses the instrument will accept before terminating the scan. See “[Trigger Count](#)” on page 109 for more information.
- If the instrument receives an external trigger before it is ready to accept one, it will buffer one trigger and then ignore any additional triggers received (no error is generated).
- All readings from the scan are stored in volatile memory. Readings accumulate in memory until the scan is terminated (until the scan count is reached or until you abort the scan).
- Mx+B scaling and alarm limits are applied to measurements during the scan and all data is stored in volatile memory.

The following program segment configures the instrument for an external scan.

<code>TRIG:SOURCE EXT</code>	Select external mode
<code>TRIG:COUNT 2</code>	Sweep the scan list 2 times
<code>INIT</code>	Initiate the scan

NOTE

To stop a scan, send the **ABORt** command.

Trigger Count

Usage:

- L4421A 40-Channel Armature Multiplexer
- L4450A 64-Bit Digital I/O (digital input, counter channels only)
- L4452A Multifunction Module (digital input, totalizer channels only)

You can specify the number of triggers that will be accepted by an instrument before returning to the “idle” state. The trigger count applies to both scanning and non-scanning applications.

- Select a trigger count between 1 and 500,000 triggers, or continuous.
- You can store at least 500,000 readings in memory and all readings are automatically time stamped. If memory overflows, the new readings will overwrite the first (oldest) readings stored; the most recent readings are always preserved.
- You can specify a trigger count in conjunction with a sweep count. The two parameters operate independent of one another, and the total number of readings returned will be the product of the two parameters.
- The **CONFigure** and **MEASure?** commands automatically set the scan trigger count to 1.
- The instrument sets the scan trigger count to 1 after a Factory Reset (***RST** command). An Instrument Preset (**SYSTem:PRESet** command) or Card Reset (**SYSTem:CPON** command) does not change the setting.

The following command sets the trigger count:

```
TRIGger:COUNT
```

To configure a continuous scan, send **TRIG:COUNT INFINITY**.

Sweep Count

Usage:

- L4450A 64-Bit Digital I/O (digital input, counter channels only)
- L4452A Multifunction Module (digital input, totalizer channels only)

The sweep count sets the number of sweeps per trigger event during a scan (a sweep is one pass through the scan list).

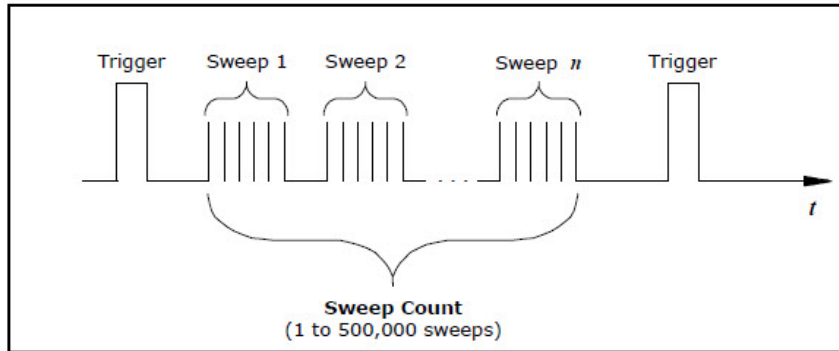

Figure 3-11 Sweep Count Diagram.

- The sweep count is valid only while scanning. If no channels have been assigned to the scan list, the specified sweep count is ignored (no error is generated).
- You can specify a sweep count in conjunction with a trigger count and a sample count. The three parameters operate independent of one another, and the total number of readings returned will be the product of the three parameters.
- You can store at least 500,000 readings in memory and all readings are automatically time stamped. If memory overflows, the new readings will overwrite the first (oldest) readings stored; the most recent readings are always preserved.
- The `CONFigure` and `MEASure?` commands automatically set the sweep count to 1 sweep.
- The instrument sets the sweep count to 1 after a Factory Reset (`*RST` command). An Instrument Preset (`SYSTem:PRESet` command) or Card Reset (`SYSTem:CPON` command) does not change the setting.
- The following command sets the sweep count:
`SWEEp:COUNT`

Channel Delay

Usage:

- L4421A 40-Channel Armature Multiplexer

You can control the pacing of a scan sweep by inserting a delay between the L4421A channels in the scan list (useful for high-impedance or high-capacitance circuits). The delay occurs following relay closure and any inherent settling time, and before the generation of the “channel closed” signal that would externally trigger a separate DMM (see “[Scanning with External Instruments](#)” on page 115).

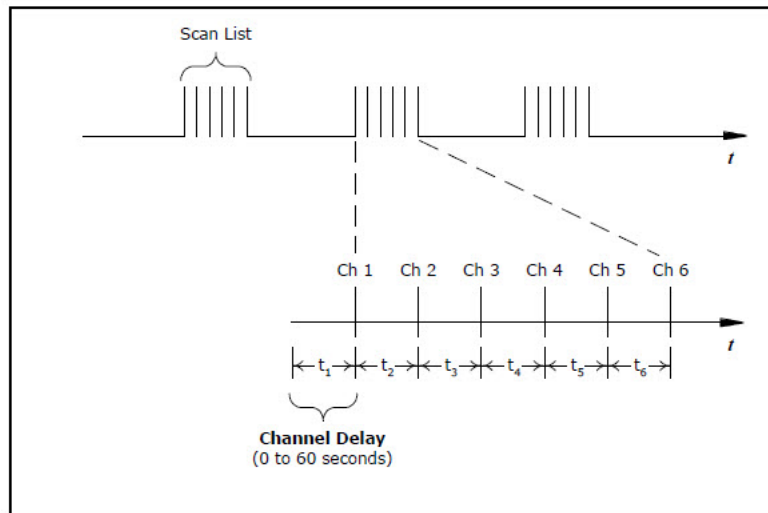

Figure 3-12 Channel Delay.

- You can set the channel delay to any value between 0 seconds and 60 seconds, with 1 ms resolution. You can select a different delay for each channel.
- You can select a unique delay for every channel on the module.
- The channel delay is valid only while scanning. If no channels have been assigned to the scan list, the specified channel delay is ignored (no error is generated).
- The default channel delay is 0.0 seconds.
- A Factory Reset (*RST command) sets the channel delay to 0.0s.

The following command adds a 2-second channel delay to the specified channels.

```
ROUT:CHAN:DELAY 2,(@1003,1013)
```

Reading Format

Usage:

- L4450A 64-Bit Digital I/O (digital input, counter channels only)
- L4452A Multifunction Module (digital input, totalizer channels only)

During a scan, the instrument automatically adds a time stamp to all readings and stores them in memory. Each reading is stored with measurement units, time stamp, channel number, and alarm status information. You can specify which information you want returned with the readings.

- The reading format applies to all readings being removed from the instrument from a scan; you cannot set the format on a per-channel basis.
- The `CONFigure` and `MEASure?` commands automatically turn off the units, time, channel, and alarm information.
- The format settings are stored in volatile memory and will be lost when power is turned off or after a Factory Reset (`*RST` command).

The following commands to select the reading format.

```
FORMat:READing:ALARm ON
```

```
FORMat:READing:CHANnel ON
```

```
FORMat:READing:TIME ON
```

```
FORMat:READing:TIME:TYPE {ABSolute|RELative}
```

```
FORMat:READing:UNIT ON
```

Non-Sequential Scanning

Usage:

- L4421A 40-Channel Armature Multiplexer
- L4450A 64-Bit Digital I/O (digital input, counter channels only)
- L4452A Multifunction Module (digital input, totalizer channels only)

By default, channels are scanned in ascending order. If your application requires non-ordered scanning of the channels in the present scan list, you can use the non-sequential scanning mode.

- When sequential scanning is enabled (default), the channels in the scan list are placed in ascending order.
- When sequential scanning is disabled (OFF), the channels remain in the order presented in the scan list. Multiple occurrences of the same channel are allowed. For example, (@1001, 1001, 1001) and (@1010,1003,1001,1005) are valid and the channels will be scanned in the order presented.
- If you define a scan list with the sequential mode enabled and later disable the mode, the scan list will not be reordered; however, the scan list will be treated as a non-sequential list thereafter.
- If you have defined a scan list with the sequential mode disabled (OFF) and later enable the mode, the channels will be reordered.
- Non-sequential scan lists are not stored as part of the instrument state by the *SAV command; in this case, the ordered mode will be enabled and the scan list will be empty when the instrument state is restored (*RCL command).
- The scan order setting is stored in volatile memory and the ordered mode will be enabled when power is turned off or after a Factory Reset (*RST command).

The command used to control the order of the scan list is:

```
ROUTE:SCAN:ORDERed {OFF|ON}
```

Monitor Mode

Usage:

- L4450A 64-Bit Digital I/O (digital input, counter channels only)
- L4452A Multifunction Module (digital input, totalizer channels only)

In the Monitor mode, the instrument takes readings as often as it can on a single channel or during a scan. This feature is useful for troubleshooting your system before a test or for watching an important signal.

- Any channel that can be “read” by a device can be monitored. This includes the digital input, totalizer, and the counter channels.
- Readings acquired during a Monitor are not stored in memory. However, all readings from a scan in progress at the same time are stored in memory.

- The Monitor mode is equivalent to making continuous measurements on a single channel with an infinite scan count. Only one channel can be monitored at a time but you can change the channel being monitored at any time.
- A scan in progress always has priority over the Monitor function.
- Channels do not have to be part of an active scan list to be monitored; however, the channel must be configured for a measurement in order to be monitored.
- The Monitor mode ignores all trigger settings and takes continuous readings on the selected channel using the IMMEDIATE (continuous) source.
- The Monitor mode is automatically enabled on all channels that are part of the active scan list. If you define the scan list after monitoring has already been enabled, any channels that are not part of the active scan list will be ignored during the monitor operation (no error is generated).
- Mx+B scaling and alarm limits are applied to the selected channel during a Monitor and all alarm data is stored in the alarm queue (which will be cleared if power fails).
- You can monitor a digital input channel or totalizer channel even if the channel is not part of the scan list. The count on a totalizer channel is not reset when it is being monitored (the Monitor ignores the totalizer reset mode).

The following command is used to enable the channel Monitor mode (default):

```
ROUTE:MONitor:MODE CHAN
```

The following program segment selects the channel to be monitored (single channel only) and enables the Monitor function.

```
ROUTE:MON:CHAN (@1003)
```

```
ROUTE:MON:CHAN:ENABLE ON, (@1003)
```

```
ROUTE:MON:STATE ON
```

To read the monitor data from the selected channel, send the following command. Each reading is returned with measurement units, time stamp, channel number, and alarm status information (see **“Reading Format”** on page 112).

```
ROUTE:MONitor:DATA?
```

Scanning with External Instruments

Usage:

- L4421A 40-Channel Armature Multiplexer

A common application of the the L4421A is to scan the multiplexer channels using a “separate” instrument such as a DMM. The DMM can be connected to the multiplexer’s COM terminals on its terminal block (Figure 3-13), or it can be connected and synchronized using the multiplexer’s “Analog Busses” and “Ext Trig” ports.

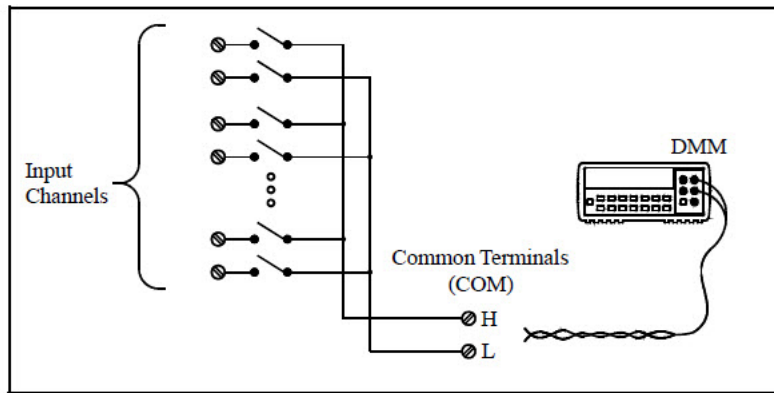

Figure 3-13 Scanning with External Instruments.

Figure 3-14 shows the connections required to make a series (scan) of two-wire measurements (e.g. ohms, DCV) using ABus1 of the L4421A.

Sequence The L4421A outputs a Channel Closed pulse on pin 5 of its Ext Trig connector when a relay is closed and has fully settled (including any channel delay). By connecting this pin to the DMM’s external trigger (Ext Trig) input, the DMM is triggered to take a measurement. When the measurement is complete, the DMM outputs a pulse from its DMM (VM Complete) output. Connecting this output to pin 1 (Channel Advance) of the L4421A’s Ext Trig connector advances the scan and closes the next channel in the scan list.

This handshake sequence continues until all channels are scanned and the programmed number of passes (sweeps) through the scan list are complete.

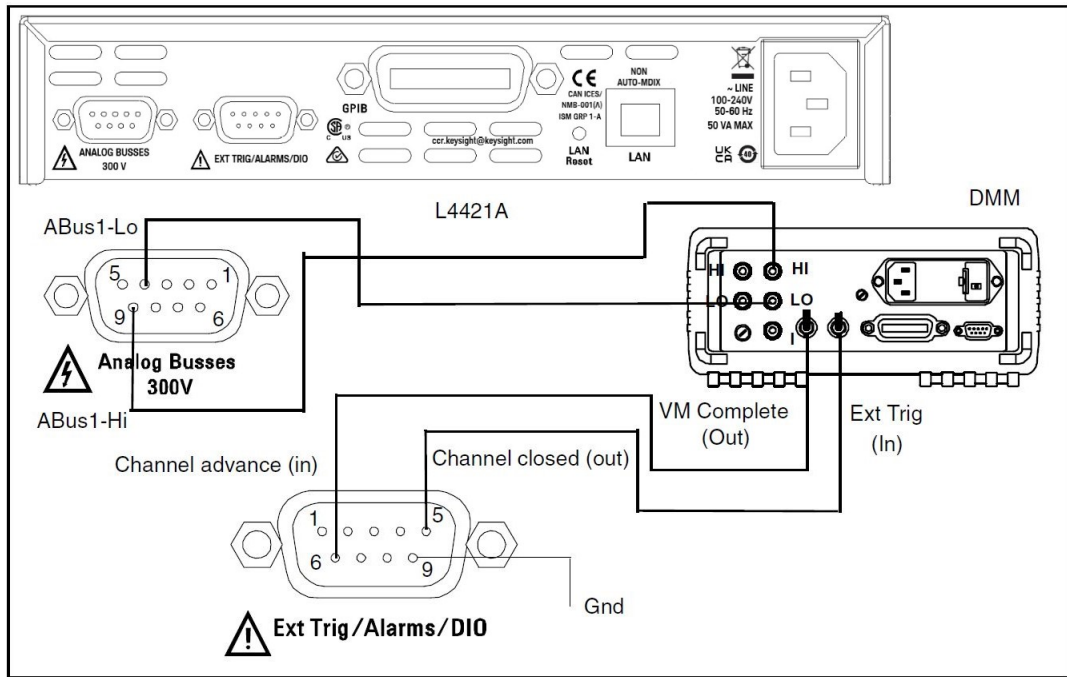

Figure 3-14 External Scanning Using the L4421A and a DMM.

- In this configuration, you must set up a scan list to include all desired multiplexer channels. Channels which are not in the list are skipped during the scan.
- You can configure the event or action that controls the onset of each sweep through the scan list (a sweep is one pass through the scan list). The selected source is used for all channels in the scan list. For more information, refer to **“Scan Trigger Source”** on page 104.
- You can configure the event or action that notifies the instrument to advance to the next channel in the scan list. Note that the Channel Advance source shares the same sources as the (scan) trigger. However, an error is generated if you attempt to set the channel advance source to the same source (other than IMMEDIATE) used for the scan trigger.

- You can specify the number of times the instrument will sweep through the scan list. When the specified number of sweeps have occurred, the scan stops. For more information, refer to “Sweep Count” on page 109.
- You can configure the list of channels for 4-wire external scanning. When enabled, the instrument automatically pairs channel n in Bank 1 with channel $n+20$ in Bank 2 to provide the source and sense connections. For example, make the source connections to the HI and LO terminals on channel 2 in Bank 1 and the sense connections to the HI and LO terminals on channel 22 (or 37) in Bank 2.

To configure the instrument for 4-wire external scanning, send the following command.

```
ROUT:CHANnel:FWIRe {OFF|ON}, (@<ch_list>)
```

The following program segment configures a separate DMM and the L4421A for one pass through a scan list of 10 channels (Figure 3-14).

<code>CONF:RES AUTO, DEF</code>	Configure DMM function (resistance)
<code>TRIG:SOUR EXT</code>	Set DMM trigger source
<code>TRIG:COUN 10</code>	Set DMM trigger count
<code>INIT</code>	Put DMM in wait-for-trigger state
<code>ROUT:SCAN (@1001:1010)</code>	Set L4421A scan list
<code>ROUT:CHAN:ADV:SOUR EXT</code>	Set L4421A channel advance source
<code>INIT</code>	Initiate the scan (close first channel)

The Example programs for the L4400 Series on www.keysight.com/find/L4400 contains complete examples (VISA, VISA-COM, IVI-COM) of scanning L4421A channels using a separate DMM. The example is in the folder “Mux_L4421A.”

Alarm Limits

Usage:

- L4450A 64-Bit Digital I/O (digital input, counter channels only)
- L4452A Multifunction Module (digital input, totalizer channels only)

You can configure the instrument to generate an alarm when a specific bit pattern or bit pattern change is detected on a digital input channel or when a specific count is reached on a totalizer channel of the L4450A and L4452A. These channels do not have to be part of the scan list to generate an alarm. Alarms are evaluated continuously as soon as you enable them.

There are two alarm paths that can be configured to alert you when specific alarm conditions are encountered during a scan. You can assign multiple channels to either of the two available alarms (ALARM1, ALARM2).

Alarm data can be stored in one of two locations depending on whether a scan is running when the alarm occurs.

- If an alarm event occurs on a channel as it is being scanned, then that channel's alarm status is stored in instrument memory as the readings are taken. Each reading that is outside the specified alarm limits is logged in memory. You can store at least 500,000 readings in memory during a scan. You can read the contents of instrument memory at any time, even during a scan. Instrument memory is not cleared when you read it.
- As alarm events are generated, they are also logged in an alarm queue, which is separate from instrument memory. This is the only place where non-scanned alarms get logged (alarms generated by the digital modules). Up to 20 alarms can be logged in the alarm queue. If more than 20 alarm events are generated, they will be lost (only the first 20 alarms are saved). Even if the alarm queue is full, the alarm status is still stored in reading memory during a scan. The alarm queue is cleared by the *CLS (clear status) command, when power is cycled, and by reading all of the entries. A Factory Reset (*RST command) or instrument preset (SYSTEM:PREset) does not clear the alarm queue.
- You can assign an alarm to any configured channel and multiple channels can be assigned to the same alarm number. However, you cannot assign alarms on a specific channel to more than one alarm number.
- When an alarm occurs, the instrument stores relevant information about the alarm in the queue. This includes the reading that caused the alarm, the time of day and date of the alarm, and the channel number on which the alarm

occurred. The information stored in the alarm queue is always in absolute time format and is not affected by the `FORMat:READing:TIME:TYPE` command setting.

- You must configure the channel before setting any alarm limits. If you change the measurement configuration, alarms are turned off and the limit values are cleared.
- If you plan to use scaling on a channel which will also use Mx+B scaling (L4450A counter function), be sure to configure the scaling values first. If you attempt to assign the alarm limits first, the instrument will turn off alarms and clear the limit values when you enable scaling on that channel. If you specify a custom measurement label with scaling, it is automatically used when alarms are logged on that channel.
- If you redefine the scan list, alarms are no longer evaluated on those channels (during a scan) but the limit values are not cleared. If you decide to add a channel back to the scan list (without changing the function), the original limit values are restored and alarms are turned back on. This makes it easy to temporarily remove a channel from the scan list without entering the alarm values again.
- Two TTL alarm outputs are available on the rear-panel Alarms connector (Figure 3-4). You can use these hardware outputs to trigger external alarm lights, sirens, or send a TTL pulse to your control system. You can also initiate a scan sweep (no external wiring required) when an alarm event is logged on a channel. For complete details, refer to “Using the Alarm Output Lines” on page 122.
- A Factory Reset (`*RST` command) clears all alarm limits and turns off all alarms. An Instrument Preset (`SYSTem:PRESet` command) or Card Reset (`SYSTem:CPON` command) does not clear the alarm limits and does not turn off alarms.
- The channel numbering scheme for the digital input and totalizer channels is shown below.

	Digital Input Channel Numbering	Totalizer Channel Numbering
L4450A	1101 through 1104 1201 through 1204	1301, 1302
L4452A	1001 through 1004	1005

- Pattern comparisons always start on the lowest-numbered channel in the bank and extend to all channels involved in the channel width.
- Alarms are evaluated continuously on the digital modules, but alarm data is stored in reading memory only during a scan.
- Each time you start a new scan, the instrument clears all readings (including alarm data) stored in reading memory from the previous scan. However, alarm data stored in the alarm queue from the digital modules is not cleared. Therefore, although the contents of reading memory are always from the most recent scan, the alarm queue may contain data that occurred during previous scans or while the instrument was not scanning.

To assign the alarm number to report any alarm conditions on the specified digital input channels, use the following command.

```
OUTPut:ALARm[1|2]:SOURce (@<ch_list>)
```

To configure alarms on the specified digital input channel, use the following commands (also see the example below).

```
CALCulate
```

```
:COMPare:TYPE {EQUa1|NEQUa1},(@<ch_list>)
```

```
:COMPare:DATA <data>,@<ch_list>
```

```
:COMPare:MASK <mask>,@<ch_list>
```

Select `EQUa1` to generate an alarm when the data read from the port is equal to `CALC:COMP:DATA` after being masked by `CALC:COMP:MASK`. Select `NEQUa1` (not equal) to generate an alarm when the data read from the port is not equal to `CALC:COMP:DATA` after being masked by `CALC:COMP:MASK`.

Use `CALC:COMP:MASK` to designate the “don’t care” bits. Bits that you set to “0” in the mask are ignored. To enable the specified alarm mode, send the following command.

```
CALCulate:COMPare:STATE ON,@<ch_list>
```

Example: *Configuring an Alarm on a Digital Input*

The following program segment sets the digital pattern for the L4450A and then enables the pattern comparison mode. When the data read from the bank is equal to the comparison pattern, an alarm is generated on Alarm 2.

<code>CALC:COMP:DATA:WORD #HF6,(@1201)</code>	Set compare pattern (1111 0110)
<code>CALC:COMP:TYPE EQUAL,(@1201)</code>	Generate alarm on match
<code>OUTP:ALARM2:SOUR (@1201)</code>	Enable alarms
<code>CALC:COMP:STAT ON,(@1201)</code>	Enable pattern compare mode

To assign the alarm number to report any alarm conditions on the specified totalizer channels, use the following command.

```
OUTPut:ALARm[1|2]:SOURce (@<ch_list>)
```

To configure an alarm on a totalizer channel, specify the desired count as the upper limit using the following command.

```
CALCulate:LIMit:UPPer <count>,@<ch_list>
```

To enable the upper limit on the specified totalizer channel, use the following command.

```
CALCulate:LIMit:UPPer:STATe ON,@<ch_list>
```

Viewing Stored Alarm Data

If an alarm occurs on a channel as it is being scanned, then that channel's alarm status is stored in reading memory as the readings are taken. As alarm events are generated, they are also logged in an alarm queue, which is separate from reading memory. This is the only place where non-scanned alarms get logged (alarms generated by the digital modules).

The following command reads data from the alarm queue (one alarm event is read and cleared each time this command is executed).

```
SYSTem:ALARm?
```

The following command retrieves scanned readings and alarm data from reading memory (the readings are not erased).

```
FETCh?
```

Using the Alarm Output Lines

As mentioned, there are two TTL alarm lines available on the rear-panel Alarms connector. Each alarm output line represents the logical “OR” of all channels assigned to that alarm number (an alarm on any of the associated channels will pulse the line). The connector is shown below:

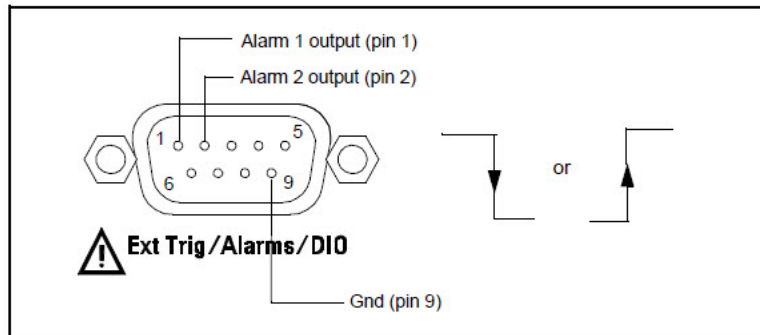

Figure 3-15 The L4400 Series Rear Panel Alarm Connector.

You can configure the behavior of the alarm output lines as follows. The configuration that you select is used for both alarm output lines. A Factory Reset (*RST command) clears the alarm outputs but does not clear the alarm queue in either configuration.

- Latch Mode: In this mode, the corresponding output line is latched true when the first alarm occurs and remains asserted until you clear it by initiating a new scan or cycling power. You can manually clear the output lines at any time (even during a scan) and the alarm data in memory is not cleared (however, data is cleared when you initiate a new scan).
- Track Mode: In this mode, the corresponding output line is asserted only when a reading crosses a limit and remains outside the limit. When a reading returns to within limits, the output line is automatically cleared. You can manually clear the output lines at any time (even during a scan) and the alarm data in memory is not cleared (however, data is cleared when you initiate a new scan). The alarm outputs are also cleared when you initiate a new scan.
- You can control the slope of the pulse from the alarm outputs (the selected configuration is used for both outputs). In the falling edge mode, 0V (TTL low)

indicates an alarm. In the rising edge mode, +5V (TTL high) indicates an alarm. A Factory Reset (*RST command) will reset the slope to falling edge.

NOTE

Changing the slope of the output lines may cause the lines to change state.

To clear the specified output line (or to clear both lines), use one of the following commands.

`OUTPUT:ALARM2:CLEAR` Clear alarm output line 2

`OUTPUT:ALARM:CLEAR:ALL` Clear both alarm outputs

To select the output configuration for the output lines, use the following command.

`OUTPut:ALARm:MODE {LATCH|TRACK}`

To configure the slope of the output lines, use the following command.

`OUTPut:ALARm:SLOPe {NEGative|POSitive}`

Using Sequences

Usage:

- All L4400 Series Instruments

This section gives information on defining and executing a sequence, which is a compiled series of SCPI commands stored in non-volatile memory and identified by a user-defined name. Sequences can be used in a variety of applications, such as creating a signal path from a device-under-test to a measurement device or sequencing relays in a specified order. You can also use sequences in conjunction with other operations to configure and synchronize complex measurements without having to send the routing commands each time.

The following tables summarize the commands used to define, execute, and manage sequences. For more information, see the Programmer's Reference Help file at www.keysight.com/find/L4400.

Sequence Definition	
ROUTe:SEQuence:DEFine <name>, "<commands>"	Defines a sequence.
ROUTe:SEQuence:DEFine? <name>	Returns sequence definition.
Sequence Execution	
ROUTe:SEQuence:ABORT	Terminates currently-running sequence.
ROUTe:SEQuence:BUSY?	Returns "1" if sequence is executing (busy).
ROUTe:SEQuence:RUNNing:NAME?	Returns name of currently-running sequence.
ROUTe:SEQuence:TRIGger[:IMMediate]	Executes specified sequence.
ROUTe:SEQuence:WAIT	Blocks until sequence has completed.
Sequence Management	
ROUTe:SEQuence:CATalog?	Returns list of defined sequence names.
ROUTe:SEQuence:DELeTe:ALL	Deletes all sequences from memory.
ROUTe:SEQuence:DELeTe[:NAME] <name>	Deletes specified sequence from memory.
Alarm Limits	
OUTPut:ALARm{1-2}:SEQuence?	Returns sequence associated with alarm.

<code>ROUTE:SEQUence:TRIGger:SOURce <name>,<source></code>	Assigns trigger source to sequence.
<code>ROUTE:SEQUence:TRIGger:SOURce? <name></code>	Returns trigger source currently selected.

Defining a Sequence

A sequence defines a series of SCPI commands with an associated name. When the sequence is first defined, the commands are compiled and then stored in a compressed format in non-volatile memory. The following SCPI commands by L4400 LXI instrument are allowed in a sequence definition (all other commands will generate an error).

L4421A / L4433A

```
ROUTE:CLOSe (@<ch_list>)
ROUTE:CLOSe:EXCLusive (@<ch_list>)
ROUTE:OPEN (@<ch_list>)
ROUTE:OPEN:ABUS [{1-4|ABUS1-ABUS4|ALL}]
ROUTE:OPEN:ALL [{1|ALL}]
ROUTE:MODule:WAIT {1|ALL}
ROUTE:SEQUence:TRIGger[:IMMediate] <name>
SYSTem:DELay[:IMMediate] <time>
ABORt
```

L4437A

```
ROUTE:CLOSe (@<ch_list>)
ROUTE:CLOSe:EXCLusive (@<ch_list>)
ROUTE:OPEN (@<ch_list>)
ROUTE:OPEN:ALL [{1|ALL}]
ROUTE:MODule:WAIT {1|ALL}
ROUTE:SEQUence:TRIGger[:IMMediate] <name>
SYSTem:DELay[:IMMediate] <time>
ABORt
```

L4445A

```
ROUTE:CLOSe (@<ch_list>)
```

```
ROUTE:OPEN (@<ch_list>)
ROUTE:MODUle:WAIT {1|ALL}
ROUTE:SEQuence:TRIGGer[:IMMediate] <name>
SYSTem:DELAy[:IMMediate] <time>
ABORt
```

L4450A

```
[SENSe:]TOTAlize:CLEAr:IMMediate (@<ch_list>)
SOURce:DIGital:DATA[:{BYTE|1|WORD|2|LWORD|4}] <data>,
(@<ch_list>)
SOURce:DIGital:DATA:BIT {0|1}, <bit>, (@<ch_list>)
ROUTE:SEQuence:TRIGGer[:IMMediate] <name>
SYSTem:DELAy[:IMMediate] <time>
ABORt
```

L4451A

```
SOURce:CURRent[:LEVel] {<current>|MIN|MAX|DEF}, (@<ch_list>)
SOURce:VOLTAge[:LEVel] {<voltage>|MIN|MAX|DEF} , (@<ch_list>)
OUTPut[:STATE] {OFF|0|ON|1}, (@<ch_list>)
ROUTE:SEQuence:TRIGGer[:IMMediate] <name>
SOURce:FUNCTion:TRIGGer:IMMediate (@<ch_list>)
SYSTem:DELAy[:IMMediate] <time>
ABORt
```

L4452A

```
[SENSe:]TOTAlize:CLEAr:IMMediate (@<ch_list>)
SOURce:DIGital:DATA[:{BYTE|1|WORD|2|LWORD|4}] <data>,
(@<ch_list>)
SOURce:DIGital:DATA:BIT {0|1}, <bit>, (@<ch_list>)
SOURce:VOLTAge[:LEVel] {<voltage>|MIN|MAX|DEF} , (@<ch_list>)
ROUTE:SEQuence:TRIGGer[:IMMediate] <name>
SYSTem:DELAy[:IMMediate] <time>
ABORt
```

- When a sequence is defined, the specified commands are checked for proper syntax and absolute parameter range limits. If an error is detected during compilation, the entire sequence will be discarded. More extensive error checking, such as channel range expansion and validation, is performed when the sequence is executed.
- If you define a sequence with a name already in use by another sequence, the new definition will overwrite the previous definition (no error is generated).
- A sequence name can contain up to 30 characters. The first character must be a letter (A-Z), but the remaining 29 characters can be letters, numbers (0-9), or an underscore (_). Blank spaces are not allowed.
- When stored in memory, the user-defined sequence names are converted to all uppercase letters. For example, when stored “MySeq_1” is converted to “MYSEQ_1”.
- A sequence may invoke another sequence, but may not invoke itself recursively. In addition, the number of invocations is limited to four levels of nesting and this is enforced at the time of execution. Exceeding the limit will abort the sequence and an error will be generated.
- At the time of sequence definition, a sequence may reference another undefined sequence; however, at the time of execution an error will be generated if an undefined sequence is invoked.
- Up to 500 unique sequences can be stored in non-volatile memory. Each sequence is limited to 1024 bytes.
- While a scan is running (see “[Scanning Applications](#)” on page 101), the instrument prevents use of all channels in banks that contain one or more channels in the specified scan list (these channels are dedicated to the scan). Therefore, if a sequence attempts to operate a channel in scanned bank, an error is generated and the entire sequence will be discarded.
- If the command overlap function is enabled, all switching operations within the sequence follow the overlapping rules. If the command overlap function is disabled, all commands within the sequence are processed in a serial fashion in the exact order in which they are received. Note, however, that within a single command containing a <ch_list> parameter (e.g., `ROUT:CLOSE (@1001:1010)`), the order of the individual switch operations is not guaranteed.

The following command defines a sequence named “MYSEQ_1”, which closes several channels on the instrument and then opens a single channel.

```
ROUT:SEQ:DEF MYSEQ_1,"ROUT:CLOS (@1001:1009);OPEN (@1001)"
```

Querying the Sequence Definition

Once you have defined a sequence, you can query the definition to review what SCPI commands have been assigned.

- The exact text specified in the original sequence definition is not preserved when the sequence is compressed/stored in memory. Therefore, the string returned may not be identical to the original string, but it will be functionally equivalent. If the specified sequence name is not currently stored in memory, an error is generated.
- The query command always returns the short form of the command header in all upper-case letters (e.g., “ROUT:CLOS” is returned instead of “ROUTE:CLOSE”). Channel numbers and channel range specifiers are returned as they were specified.

The following command returns a string containing the SCPI commands assigned to the specified sequence.

```
ROUT:SEQ:DEF? MYSEQ_1
```

The above command returns a string in the form (the quotes are also returned):

```
":ROUT:CLOS (@1001:1009);:ROUT:OPEN (@1001)"
```

Executing a Sequence

After you have defined a valid sequence, you can execute it to process the specified commands. If the specified sequence name is not currently stored in memory, an error will be generated.

- If you attempt to trigger a sequence while one is already executing, the trigger will be placed in a queue. When the trigger queue is full, a “trigger ignored” error will be generated.
- To abort a sequence execution, use the `ROUTE:SEQUENCE:ABORT` command or a `Device Clear`. When the sequence is terminated, the resultant instrument state will be determined by how much of the sequence had been executed when the `ABORT/Device Clear` was received. An `ABORT` command (system abort) executed from within a sequence will not terminate the sequence, but will abort a scan. The `*RST` and `SYSTEM:PRESET` commands will also abort a sequence execution prior to performing their own actions.
- When a sequence is defined, the specified commands are checked for proper syntax and absolute parameter range limits. If an error is detected during

compilation, the entire sequence will be discarded. More extensive error checking, such as channel range expansion and validation, is performed when the sequence is executed.

- A sequence may invoke another sequence. but may not invoke itself recursively. In addition, the number of invocations is limited to four levels of nesting and this is enforced at the time of execution. Exceeding the limit will abort the sequence and an error will be generated.
- You can also execute a sequence when an alarm condition is reached. See [“Executing a Sequence on an Alarm Condition”](#) on page 129 for more information.
- While a scan is running (see [“Scanning Applications”](#) on page 101), the instrument prevents use of all channels in banks that contain one or more channels in the specified scan list (these channels are dedicated to the scan). Therefore, if a sequence attempts to operate a channel in a scanned bank, an error is generated and the entire sequence will be discarded.
- The following command executes a sequence named “MYSEQ_1”, which closes several channels on the module and opens a single channel.

```
ROUT:SEQ:DEF MYSEQ_1,"ROUT:CLOS (@1001:1009);OPEN (@1011)"
ROUT:SEQ:TRIG MYSEQ_1
```

Executing a Sequence on an Alarm Condition

After you have defined a valid sequence, you can configure the instrument to execute a sequence when a reading crosses an alarm limit on a channel. The specified sequence will execute once when an alarm occurs on the specified alarm. If the specified sequence name is not currently stored in memory, an error will be generated.

For more information on configuring alarms, see [“Alarm Limits”](#) on page 118.

- Assigning a sequence to an alarm will remove any other sequence's association with that alarm, as well as that alarm's association to any other sequence.
- You can assign multiple channels to either of the two available alarms (numbered 1 and 2). You cannot, however, assign alarms on a specific channel to more than one alarm number.

- The sequence will execute once when an alarm occurs, after which the trigger source will be automatically set to MANual. The sequence will not execute again until the trigger source has been reassigned, the alarm has been cleared, the association of the sequence to the alarm has been re-established, and the alarm condition exists again.

To assign the sequence to a specific alarm number, use the following command. Specify the `MANua1` parameter to remove an association without reassigning it to another alarm.

```
ROUTe:SEQuence:TRIGger:SOURce <name>,{ALARm1-ALARm2|MANua1}
```

The following program segment selects the alarm source and configures the instrument (L4450A) to execute the sequence named “TOTAL_1” when an alarm (count of 50) is reported on Alarm 1. The Monitor mode is used to evaluate alarm conditions on the selected channel.

```
ROUT:SEQ:DEF TOTAL_1,"SYST:DEL 1000"  
CALC:LIM:UPP 10.25,(@1301)  
CALC:LIM:UPP:STAT ON,(@1301)  
OUTP:ALARM1:SOUR (@1301)  
ROUT:MON:CHAN (@1301)  
ROUT:MON:CHAN:ENAB ON, (@1301)  
ROUT:SEQ:TRIG:SOUR TOTAL_1,ALAR1  
ROUT:MON:STAT ON  
INIT
```

Deleting Sequences

You can delete sequences to free up space in memory previously allocated for the sequence.

- If you attempt to delete a sequence while it is executing, an error will be generated. To abort a sequence execution, use the `ROUTe:SEQuence:ABORT` command or a `Device Clear`.
- Deleting a sequence will remove its association with an alarm if used (see [“Executing a Sequence on an Alarm Condition”](#) on page 129 for more information).

The following command deletes the sequence named “TOTAL_1”.

```
ROUT:SEQ:DEL TOTAL_1
```

The following command deletes all sequences from memory.

```
ROUT:SEQ:DEL:ALL
```

Reading the List of Stored Sequences

You can read the names of all sequences currently stored in memory.

- When stored in memory, the user-defined sequence names are converted to all uppercase letters. For example when stored, “Total_1” is converted to “TOTAL_1”.
- Up to 500 unique sequences can be stored in non-volatile memory. Each sequence is limited to 1024 bytes.

The following command returns a comma-separated list of sequence names currently stored.

```
ROUT:SEQ:CAT?
```

The above command returns a string in the form:

```
MYSEQ_1,PATH_DUT1,SW_PATH2
```

If no sequence names have been stored, a null string (“ ”) string is returned.

Instrument State Storage

Usage:

- All L4400 Series Instruments

The L4400 series instruments have five storage locations in non-volatile memory numbered 1 through 5 to store instrument states. A sixth location stores the instrument's power down state which is restored when the instrument is turned back on. You can assign a user-defined name to each of locations 1 through 5.

- You can store the instrument state in any of the four locations, but you can only recall a state from a location that contains a previously stored state.
- When shipped from the factory, storage locations 1 through 5 are empty. In addition, the automatic recall mode is disabled (`MEMory:STATe:RECa11:AUTO OFF` command) and a Factory Reset (`*RST` command) is issued when power is turned on.
- You can name a storage location, but the location is recalled using the location number. The name can contain up to 12 characters. The first character must be a letter (A-Z), but the remaining 11 characters can be letters, numbers (0-9), or the underscore character (“_”). Blank spaces are not allowed.
- A Factory Reset (`*RST` command) does not affect the configurations stored in memory. Once a state is stored, it remains until it is overwritten or specifically deleted.

The following commands are used to store and recall instrument states.

```
*SAV {1|2|3|4|5}
```

```
*RCL {1|2|3|4|5}
```

To configure the instrument to automatically recall location 2 when power is restored, send the following commands.

```
*SAV 2
```

```
MEM:STATE:RECALL:SELECT 2
```

```
MEM:STATE:RECALL:AUTO ON
```

Error Conditions

Usage:

- All L4400 Series Instruments

When the L4400 instrument's front panel ATTN LED is red, one or more command syntax or hardware errors have been detected. A record of up to 20 errors can be stored in the instrument's error queue.

For a complete listing of the error messages, see the Programmer's Reference Help file located at www.keysight.com/find/L4400.

- A special global error queue holds all power-on and hardware-related errors (e.g., over-temperature, Safety Interlock, etc.).
- Errors are retrieved in first-in-first-out (FIFO) order. The first error returned is the first error that was stored. Errors are cleared as you read them. Once you have read all of the interface-specific errors, the errors in the global queue are retrieved.
- Errors are cleared as you read them. When you have read all errors from the interface-specific and global error queues, the ATTN annunciator turns off.
- If more than 20 errors have occurred, the last error stored in the queue (the most recent error) is replaced with -350, "Error queue overflow". No additional errors are stored until you remove errors from the queue. If no errors have occurred when you read the error queue, the instrument responds with +0, "No error".
- The interface-specific and global error queues are cleared by the *CLS (Clear Status) command and when power is cycled. The errors are also cleared when you read the error queue. The error queue is not cleared by a Factory Reset (*RST command) or an Instrument Preset (SYSTEM:PRESet command).

The following command is used to read errors from the error queue. One error is read per command.

```
SYSTEM:ERRor?
```

Relay Cycle Count

Usage:

- L4421A 40-Channel Armature Multiplexer
- L4433A Dual/Quad 4x8 Reed Matrix
- L4437A General Purpose Switch
- L4445A Microwave Switch/Attenuator

The number of relay cycles can be determined to help you predict relay end-of-life. The instrument counts the cycles on each relay and stores the total count in non-volatile memory.

- In addition to the channel relays, you can also query the count on the Analog Bus relays and bank relays.
- You can reset the cycle count on any of the channel relays, Analog Bus relays, or bank relays but the instrument must be unsecured. See Chapter 11 for information on unsecuring the instrument.

The following command is used to read the cycle count on the specified instrument channel(s):

```
DIAG:RELAY:CYCLES? (@<ch_list>)
```

The following command is used to reset the cycle count on the specified instrument channel(s):

```
DIAG:RELAY:CYCLES:CLEAR (@<ch_list>)
```

Calibration Overview

Usage:

- L4451A 4-Channel Isolated D/A Converter
- L4452A Multifunction Module

The L4400 series instruments requiring calibration are the L4451A and the L4452A. Calibration procedures for these instruments are contained in [Appendix A L4451A and L4452A Calibration Procedures](#).

THIS PAGE HAS BEEN INTENTIONALLY LEFT BLANK.

4 L4421A 40-Channel Armature Multiplexer

Low Frequency Multiplexer Switch Instrument	134
L4421A Measurement Functions	135
L4421A SCPI Command Summary	136
L4421A Example Program Segments	139
L4421A 40-Channel Armature Multiplexer Hardware Description	141
34921T Terminal Block	145

Low Frequency Multiplexer Switch Instrument

The L4421A low frequency multiplexer (MUX) switch module features two banks of channels that provide broad multiplexing and measuring capabilities. You can close more than one channel in each bank simultaneously (N:1 configuration) on the multiplexer.

WARNING

Safety Interlock - The Analog Buses of the L4400 series instruments are capable of carrying 300V signals. The L4421A instrument has a hardware Safety Interlock feature that automatically opens the analog bus relays when the associated interlock pins on the D-sub connectors (faceplate) lose continuity. This prevents signals on the analog buses from being present on the D-sub connector pins. Optional terminal blocks available from Agilent automatically provide continuity for these interlock pins. If cables are used, you must provide continuity for the interlock pins in your DUT assembly. See the pinout information later in this chapter for the location of interlock pins on each module.

The L4421A has analog bus relays on each of its two banks. Therefore, the interlock pins are present on both the Bank 1 and Bank 2 D-sub connectors on the module.

Normally, if you attempt to connect to the analog buses without a terminal block or cable connected, an error is generated. The `SYSTEM:ABUS:INTERlock:SIMulate` command allows you to temporarily disable errors generated by the Safety Interlock feature and enables the simulation mode. Although Safety Interlock errors are suppressed in this mode, the actual analog bus relays affected by the Safety Interlock are disabled as long as no terminal block or cable is connected to the module.

L4421A Measurement Functions

The L4421A supports the measurement functions shown in [Table 4-1](#). Measurements are made by routing the signals on the multiplexer to a separate digital multimeter (DMM) instrument using the L4421A analog bus.

Table 4-1 L4421A Supported Measurement Functions.

Function	Notes
Voltage, AC/DC	
Current, AC/DC	direct current measurements are allowed on channels 41 through 44 only - external shunts are required for all other channels
Frequency / Period	
Ohms, 2-wire	
Ohms, 4-wire	
Thermocouple	Optional 34921 T Terminal Block is required for thermocouple measurements with built-in internal reference junction
RTD, 2-wire	
RTD, 4-wire	
Thermistor	

L4421A SCPI Command Summary

Table 4-2 lists the instrument-specific SCPI commands that apply to the L4421A 40-channel Armature Multiplexer. Table 3-3 (Chapter 3) lists the SCPI commands that apply to all L4400 series instruments.

For complete information on all SCPI commands, refer to the Programmer's Reference contained at www.keysight.com/find/L4400.

Table 4-2 L4421A SCPI Command Summary.

Subsystem	Commands
ROUTE (Scan Configuration)	ABORt
	INITiate
	ROUTe:CHANnel:ADVance:SOURce {EXternal BUS IMMEDIATE}
	ROUTe:CHANnel:ADVance:SOURce?
	ROUTe:CHANnel:DELay (@<ch_list>)
	ROUTe:CHANnel:DELay? (@<ch_list>)
	ROUTe:CHANnel:DELay:AUTO {OFF 0 ON 1}, (@<ch_list>)
	ROUTe:CHANnel:DELay:AUTO? (@<ch_list>)
	ROUTe:CHANnel:FWIRe {OFF 0 ON 1}, (@<ch_list>)
	ROUTe:SCAN (@<scan_list>)
	ROUTe:SCAN?
	ROUTe:SCAN:ADD (@<ch_list>)
	ROUTe:SCAN:ORDERed {OFF 0 ON 1}
	ROUTe:SCAN:ORDERed?
	ROUTe:SCAN:REMOve (@<ch_list>)
	ROUTe:SCAN:SIZE?

Subsystem	Commands
ROUTE (Switch Control)	ROUTE:CHANnel:LABel:CLEar:MODule 1
	ROUTE:CHANnel:LABel[:DEFine] "<label>", (@<ch_list>)
	ROUTE:CHANnel:LABel[:DEFine]? [{USER FACTory},]
	(@<ch_list>)
	ROUTE:CLOSe (@<ch_list>)
	ROUTE:CLOSe? (@<ch_list>)
	ROUTE:CLOSe:EXCLusive (@<ch_list>)
	ROUTE:MODule:BUSY? 1
	ROUTE:MODule:WAIT 1
	ROUTE:MODule:WAIT? 1
	ROUTE:OPEN (@<ch_list>)
	ROUTE:OPEN? (@<ch_list>)
	ROUTE:OPEN:ABUS {1-4 ABUS1-ABUS4 ALL}
	ROUTE:OPEN:ALL 1
ROUTE[:OPERation]:OVERlap[:ENABle] {OFF ON 1}	
ROUTE[:OPERation]:OVERlap[:ENABle]?	
ROUTE (Sequence Operation)	ROUTE:SEQuence:ABORt
	ROUTE:SEQuence:BUSY?
	ROUTE:SEQuence:CATalog?
	ROUTE:SEQuence:DEFine <name>, "<commands>"
	ROUTE:SEQuence:DEFine? <name>
	ROUTE:SEQuence:DELeTe:ALL
	ROUTE:SEQuence:DELeTe[:NAME] <name>
	ROUTE:SEQuence:RUNNing:NAME?
	ROUTE:SEQuence:TRIGger[:IMMediate] <name>
	ROUTE:SEQuence:TRIGger:SOURce <name>, MANual
ROUTE:SEQuence:TRIGger:SOURce? <name>	
ROUTE:SEQuence:WAIT	
SENSe (Temperature Sensing)	[SENSe]:TEMPerature:RJUNction[:INTernal]?
SYSTEM	SYSTEM:ABUS:INTerlock:SIMulate {OFF ON 1}
	SYSTEM:ABUS:INTerlock:SIMulate?

Subsystem	Commands
TRIGger (Triggering Commands)	TRIGger:COUNT {<count> MIN MAX DEF INFinity}
	TRIGger:COUNT? [{MIN MAX}]
	TRIGger:DElay:AUTO {OFF 0 ON 1}
	TRIGger:DElay:AUTO?
	TRIGger:SOURce {IMMediate BUS EXternal TIMER}
	TRIGger:SOURce?
	TRIGger:TIMer {<seconds> MIN MAX DEF}
TRIGger:TIMer? [{MIN MAX}]	
DIAGnostic	DIAGnostic:RElay:CYCLes? (@<ch_list>)
	DIAGnostic:RElay:CYCLes:CLEar (@<ch_list>)

L4421A Example Program Segments

The following sections contain example program segments of commonly used instrument functions.

For detailed example programs involving multiple drivers and development environments, refer to the example programs for the L4400 Series on www.keysight.com/find/L4400.

Opening and Closing Channels

Example: Closing and opening channels This command closes the specified channels on the L4421A. If any channel in a bank is defined to be part of the scan list, and a scan is occurring, attempting to close another channel (including Analog Bus channels) within the same bank will result in an error. Channel closures in the other bank are allowed as long as no channels are part of the scan list.

The following commands close and open channels 13 and 15 through 18.

```
ROUTE:CLOSE (@1013,1015:1018)
```

```
ROUTE:OPEN (@1013,1015:1018)
```

Example: Closing and opening Analog Bus relays The following command connects the Analog Buses to Bank 1 (via the Analog Bus relays on Bank 1).

```
ROUTE:CLOSE (@1911,1912,1913,1914)
```

```
ROUTE:OPEN (@1911,1912,1913,1914)
```

The analog bus relays (numbered 1911, 1912, 1913, 1914) on the L4421A are ignored if they are included in a range of channels. An error will be generated if an analog bus relay is specified as the first or last channel in a range of channels. For example, the following command closes all channels between channels 1 and 30. In addition, this command closes analog bus relay 1911.

```
ROUTE:CLOSE (@1001:1030,1911)
```

Example: Querying channels for open or close state The following command returns a 1 (true) or 0 (false) state of channel 036.

```
ROUTE:CLOSE (@1036)
```

```
ROUTE:CLOSE? (@1036) !Returns a 1
```

```
ROUTE:OPEN? (@1036) !Returns a 0
```

Example: Querying the Identity of the Instrument The following command returns the identity of the L4421A:

```
SYSTem:CTYPe? 1
```

Querying and Clearing Cycle Count, and Resetting Modules

Example: Querying the cycle count for a relay The following command returns the cycle count on channels 7 and 16.

```
DIAGnostic:RELAy:CYCLes? (@1007,1016)
```

Example: Clearing the cycle count for a relay The following command resets the cycle count to zero on the channels 7 and 16 for a MUX module in slot 1.

```
DIAGnostic:RELAy:CYCLes:CLEar (@1007,1016)
```

Example: Resetting module(s) to power-on state The following command resets the L4421A to its power-on state.

```
SYSTem:CPON 1
```

L4421A 40-Channel Armature Multiplexer Hardware Description

The L4421A 40- Channel Armature Multiplexer is divided into two banks with 20 latching armature switches (channels 1- 20 and 21- 40) in each. The instrument also offers four additional fused relays (channels 41- 44) for making AC and DC current measurements with no external shunts needed. These current channels feature “make- before- break” connections to ensure continuous current flow when switching from one current channel to another. The current fuses are replaceable. Refer to the L4400 Service Guide for specific information about these fuses.

CAUTION

The current fuses are only replaceable by servicing by authorized Keysight service centers. Fuses rated 1.5A, 250Vac only provided for instrument protection only.

CAUTION

Install current limiting devices between high energy sources and the module inputs.

CAUTION

Ensure that the current limiting devices / snubber circuits are appropriate for the signal being tested.

This module also contains nine armature analog bus relays (channels 911- 914, 921- 924, and 931), four on each bank that can connect the bank relays to the system analog buses and one that connects the current relays to the current (I) and LO (L) terminals of ABus1. Through ABus1 and ABus2 you can connect any of the channels to a DMM for voltage or resistance measurements. Refer to the simplified schematic on [page 142](#).

NOTE

ABus1 consists of three wires that are used for current and voltage measurements. You cannot measure current and voltage on ABus1 simultaneously.

You can control each of the channel switches individually, and thus configure the instrument in these modes:

- two independent 20- channel 2- wire MUXes. This configuration requires neither using external wiring nor connecting through the internal Analog Buses.
- one 20- channel 4- wire MUX. This configuration requires neither using external wiring nor connecting through the internal Analog Buses. For 4- wire resistance measurements, the instrument automatically pairs channel n on Bank 1 with channel $n+20$ (Bank 2) to provide the source and sense connections. Four- wire controls require execution of the `ROUTE:CHANnel:FWIRe` command or scanning a channel previously configured as 4- wire.
- one 40- channel 2- wire MUX. You must use external wiring or connect through the internal analog bus relays for this configuration. For example, closing analog bus channels 913 and 923 connects Bank 1 and Bank 2 through ABus3. Or, externally you can connect COM1 to COM2 to create this configuration.

Low thermal offset voltage makes the L4421A ideal for low- level signal switching. The 34921T optional terminal block provides a built- in thermocouple reference junction that helps minimize errors due to thermal offset when you measure thermocouples.

The L4421A has the capability to scan as many as 100 channels/second using modern DMMs. With the automatic “break- before-make” connection operation, you are assured that no two signals are connected to each other during a scan. When using the module in a non- scanning mode, you can close as many channels as you wish.

This module is safety interlock protected, which means whenever the D- sub connector end of the instrument is exposed, the analog bus relays automatically open and disconnect from the analog bus. For more information, refer to [page 134](#) and [page 142](#).

When power is off, all channel relays maintain state, and the analog bus relays open.

L4421A Simplified Schematic

This drawing shows the L4421A configured as two independent 20- channel 2- wire MUXes.

NOTE

The three-digit number assigned to each switch represents the channel number.

Bank Relays: Armature latching

Analog Bus Relays: Armature non-latching

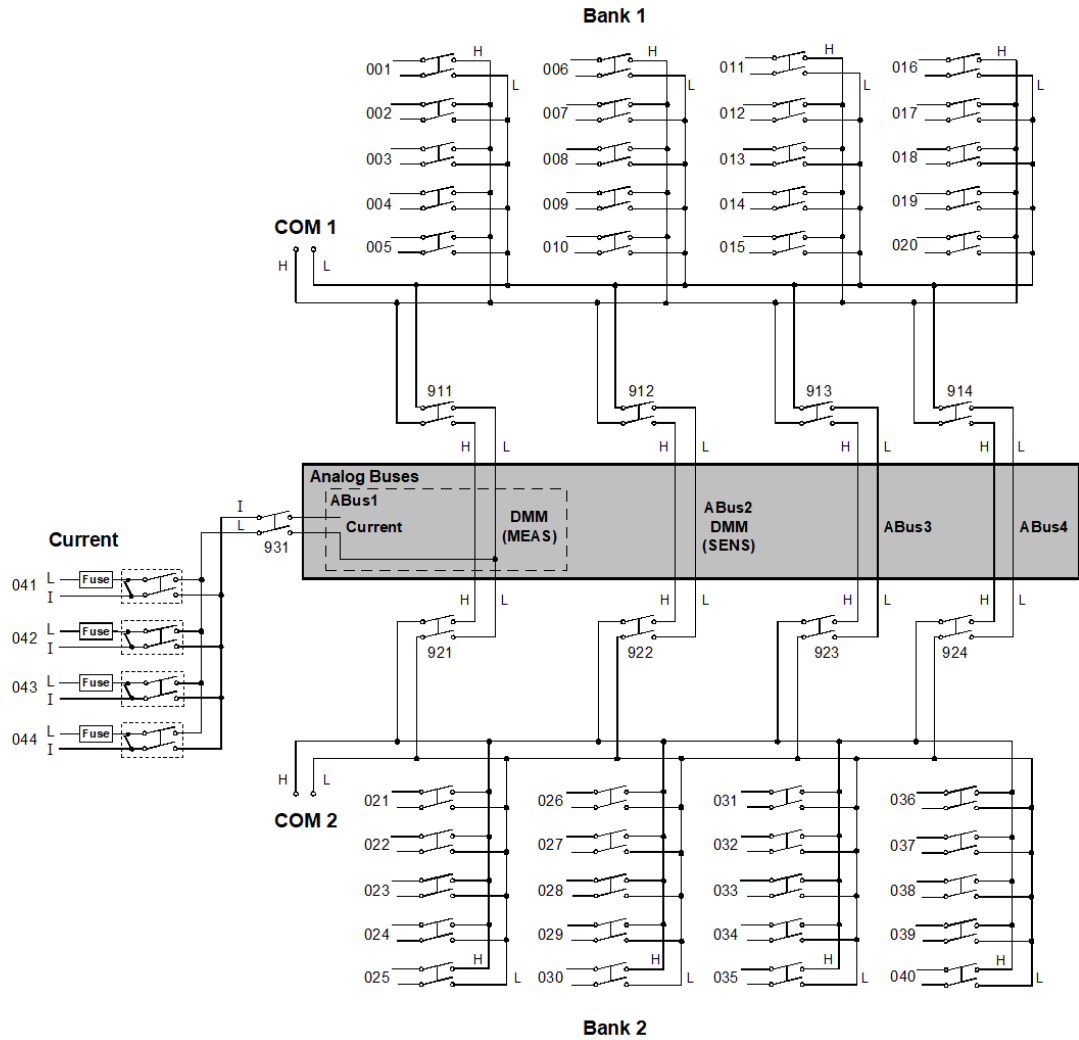

L4421A D-Sub Connectors



Bank 1

For orientation, the D-sub connector end of the module is facing you.

*TSIL represents Temperature Sensor Interface Line. This line is used for temperature interface only.

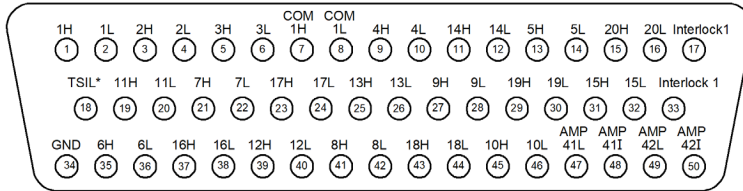

50-Pin D-Sub Male Connector

WARNING As a safety feature, interlock 1 pins (17 and 33) on Bank 1 must be shorted to enable the Bank 1 Analog Bus relays to close. The optional 34921T terminal block shorts these pins for you. This feature protects inadvertent routing of high voltages from the Analog Bus to the D-sub connector of the module.

Description	Pin	Description	Pin	Description	Pin	Description	Pin	Description	Pin
1H	1	6H	35	11H	19	16H	37	COM1 H	7
1L	2	6L	36	11L	20	16L	38	COM1 L	8
2H	3	7H	21	12H	39	17H	23	Interlock 1	17
2L	4	7L	22	12L	40	17L	24	Interlock 1	33
3H	5	8H	41	13H	25	18H	43	GND	34
3L	6	8L	42	13L	26	18L	44	TSIL*	18
4H	9	9H	27	14H	11	19H	29	AMP 41L	47
4L	10	9L	28	14L	12	19L	30	AMP 41I	48
5H	13	10H	45	15H	31	20H	15	AMP 42L	49
5L	14	10L	46	15L	32	20L	16	AMP 42I	50

Bank 2

*TSIL represents Temperature Sensor Interface Line. This line is used for temperature interface only.

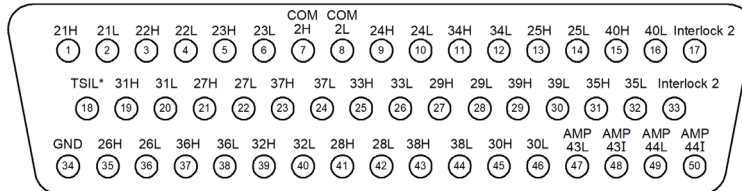

50-Pin D-Sub Male Connector

WARNING As a safety feature, interlock 2 pins (17 and 33) on Bank 2 must be shorted to enable the Bank 2 Analog Bus relays to close. The optional 34921T terminal block shorts these pins for you. This feature protects inadvertent routing of high voltages from the Analog Bus to the D-sub connector of the module.

Description	Pin	Description	Pin	Description	Pin	Description	Pin	Description	Pin
21H	1	26H	35	31H	19	36H	37	COM2 H	7
21L	2	26L	36	31L	20	36L	38	COM2 L	8
22H	3	27H	21	32H	39	37H	23	Interlock 2	17
22L	4	27L	22	32L	40	37L	24	Interlock 2	33
23H	5	28H	41	33H	25	38H	43	GND	34
23L	6	28L	42	33L	26	38L	44	TSIL*	18
24H	9	29H	27	34H	11	39H	29	AMP 43L	47
24L	10	29L	28	34L	12	39L	30	AMP 43I	48
25H	13	30H	45	35H	31	40H	15	AMP 44L	49
25L	14	30L	46	35L	32	40L	16	AMP 44I	50

34921T Terminal Block

This terminal block with screw- type connections is labeled with the model number and the abbreviated module name.

NOTE

All modules that connect to the analog bus are interlock protected. This means that when an installed module is exposed (no terminal block or cable is connected), the analog bus relays are open and disconnected from the analog buses. See [page 134](#) for further information.

The 34921T is the only terminal block that provides an isothermal block with temperature reference for thermocouple measurements. The temperature sensor is located on the bottom side of the PC board as shown below. Also shown are two holes that you can use for connecting an external temperature reference to the terminal block.

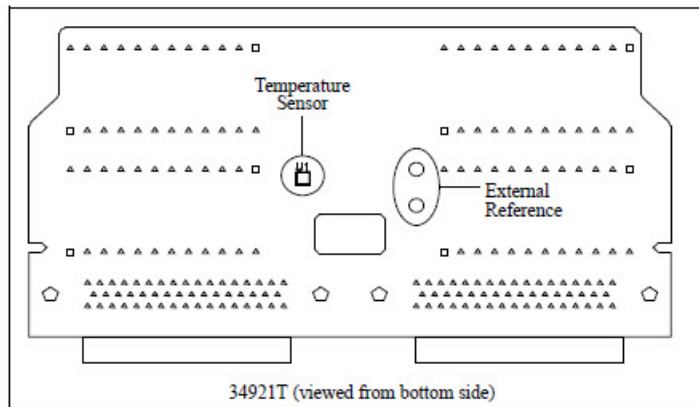

WARNING

The insulation of the wiring used with the terminal block must be rated for the highest voltage that will be present on the terminal block or on the analog bus.

CAUTION

When wiring the terminal block via cables to the mainframe, make sure the cables are connected to the correct connector. The cables provide communication and power to the temperature sensor on the 34921T terminal block. If cabling is not correct, an error may occur indicating that the L4421A module is not fully operational.

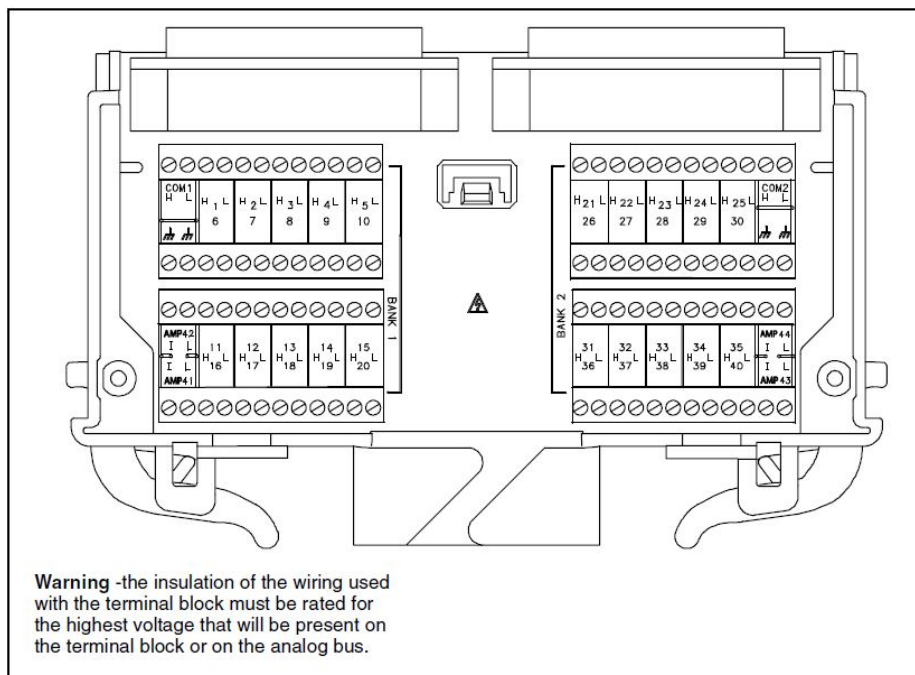

Figure 4-1 34921T Terminal Block.

5 L4433A Dual/Quad 4x8 Reed Matrix

Matrix Switch Instrument	146
L4433A SCPI Command Summary	147
L4433A Example Program Segments	149
Linking Multiple L4433A Instruments	152
L4433A Dual/Quad 4x8 Reed Matrix Hardware Description	153
34933T-001 Terminal Block for Two-Wire Mode	158
34933T-002 Terminal Block for One-Wire Mode	162

Matrix Switch Instrument

The L4433A Dual/Quad 4x8 Reed Matrix switch offers a convenient way for you to connect multiple instruments to multiple points on your DUT. For a lower cost and better specification alternative, you can connect both the L4433A matrix instrument and the L4421A multiplexer instrument.

Although flexible, it is possible to connect more than one source at the same time with the matrix. Make sure that dangerous or unwanted conditions are not created by these connections.

The features of the L4433A include:

- Non-latching reed switches that can be configured for:
 - differential (2-wire) mode, which has two (dual) matrices. Each matrix is organized in a 4-row by 8-column configuration.
 - single-ended (1-wire) mode, which has four (quad) matrices. Each matrix is organized in a 4-row by 8-column configuration.

NOTE

Safety Interlock

The Analog Buses of the L4400 series instruments are capable of carrying 300V signals. The L4433A instrument has a hardware Safety Interlock feature that automatically opens the analog bus relays when the associated interlock pins on the D-sub connectors (faceplate) lose continuity. This prevents signals on the analog buses from being present on the D-sub connector pins. Optional terminal blocks available from Agilent automatically provide continuity for these interlock pins. If cables are used, you must provide continuity for the interlock pins in your DUT assembly. See the pinout information later in this chapter for the location of interlock pins on each module.

The L4433A matrix instrument has analog bus relays on Bank 2 only. Therefore, the interlock pins are present on only the Bank 2 D-sub connectors.

Normally, if you attempt to connect to the analog buses without a terminal block or cable connected, an error is generated. The `SYSTEM:ABUS:INTERlock:SIMulate` command allows you to temporarily disable errors generated by the Safety Interlock feature and enables the simulation mode. Although Safety Interlock errors are suppressed in this mode, the actual analog bus relays affected by the Safety Interlock are disabled as long as no terminal block or cable is connected to the module.

L4433A SCPI Command Summary

Table 5-1 lists the instrument-specific SCPI commands that apply to the L4433A Dual/Quad 4x8 Reed Matrix. **Table 3-3** (Chapter 3) lists the SCPI commands that apply to all L4400 series instruments.

For complete information on all SCPI commands, refer to the Programmer's Reference at www.keysight.com/find/L4400.

Table 5-1 L4433A SCPI Command Summary

Subsystem	Commands
ROUTe (Switch Control)	ROUTe:CHANnel:LABel:CLEar:MODule 1
	ROUTe:CHANnel:LABel[:DEFine] "<label>" , (@<ch_list>)
	ROUTe:CHANnel:LABel[:DEFine]? [{USER FACTory},] (@<ch_list>)
	ROUTe:CLOSe (@<ch_list>)
	ROUTe:CLOSe? (@<ch_list>)
	ROUTe:CLOSe:EXCLusive (@<ch_list>)
	ROUTe:MODule:BUSY? 1
	ROUTe:MODule:WAIT 1
	ROUTe:MODule:WAIT? 1
	ROUTe:OPEN (@<ch_list>)
	ROUTe:OPEN? (@<ch_list>)
	ROUTe:OPEN:ABUS {1-4 ABUS1-ABUS4 ALL}
	ROUTe:OPEN:ALL 1
	ROUTe[:OPERation]:OVERlap[:ENABLE] {OFF 0 ON 1}
	ROUTe[:OPERation]:OVERlap[:ENABLE]?

Subsystem	Commands
ROUTE (Sequence Operation)	ROUTe:SEQuence:ABORT ROUTe:SEQuence:BUSY? ROUTe:SEQuence:CATalog? ROUTe:SEQuence:DEFine <name>, "<commands>" ROUTe:SEQuence:DEFine? <name> ROUTe:SEQuence:DELeTe:ALL ROUTe:SEQuence:DELeTe[:NAME] <name> ROUTe:SEQuence:RUNNing:NAME? ROUTe:SEQuence:TRIGger[:IMMediate] <name> ROUTe:SEQuence:TRIGger:SOURce <name>, MANual ROUTe:SEQuence:TRIGger:SOURce? <name> ROUTe:SEQuence:WAIT
SYSTEM	SYSTem:MODule:WIRE:MODE {WIRE1 WIRE2}, 1 SYSTem:ABUS:INTerlock:SIMulate {OFF ON 1} SYSTem:ABUS:INTerlock:SIMulate?
DIAGNOSTIC	DIAGnostic:RELAy:CYCLes? (@<ch_list>) DIAGnostic:RELAy:CYCLes:CLEar (@<ch_list>)

L4433A Example Program Segments

The following sections contain example program segments of commonly used instrument functions.

The channel addressing scheme used in these examples follow the general form 1ccc where ccc is the three-digit channel number. The channel numbers for the L4433A are derived as follows:

Two-wire mode: For two-wire mode, the channel numbers are derived from the crosspoint or intersection of rows and columns, columns having two digits. See the example below.

Displayed Channel	Means This...
1304	An L4433A (2-wire mode) where the crosspoint is row 3, column 4.

One-wire mode: For one-wire mode, the channel numbers are derived from a specific matrix number and the crosspoint or intersection of rows and columns on that matrix. See the example below.

Displayed Channel	Means This...
1437	An L4433A in 1-wire mode with matrix 4 and the crosspoint is row 3, column 7.

For information on specific configurations, refer to the simplified schematics for the L4433A later in this chapter.

For detailed example programs involving multiple drivers and development environments, refer to the example programs for the L4400 Series on www.keysight.com/find/L4400 Setting 1-wire and 2-wire Modes.

Example: Configuring the L4433A for 2-wire or 1-wire mode The following command configures the L4433A for 1-wire measurements. If you are using terminal blocks with the L4433A module, be sure to use the corresponding 2-wire or 1-wire terminal block.

```
SYSTem:MODUle:WIRE:MODE WIRE1,1
```

NOTE

After changing the (1-wire / 2-wire) mode on the L4433A, you must cycle power on the L4433A for the new mode setting to take effect.

Opening and Closing Channels

Example: Closing and opening matrix channels (two-wire mode) The following commands close and open channels 311 and 312 through 315 of the L4433A in 2-wire mode. The channel number represents the matrix crosspoint of a row (one digit) and a column (two digits). For example, channel 311 represents crosspoint at row 3 and column 11.

```
ROUTE:CLOSE (@1311,1312:1315)
```

```
ROUTE:OPEN (@1311,1312:1315)
```

Example: Closing and opening matrix channels (L4433A in one-wire mode)

The following commands close and open channels 311 and 312 through 315 of the L4433A in 1-wire mode. The channel number represents the matrix and the matrix crosspoint of a row (one digit) and a column (one digit). For example, channel 311 represents the crosspoint on matrix 3 at row 1, column 1 on the L4433A in 1-wire mode.

```
ROUTE:CLOSE (@1311,1312:1315)
```

```
ROUTE:OPEN (@1311,1312:1315)
```

NOTE

Although the previous two examples show the same channel numbers, the channels are derived differently as determined by a module's configuration mode. See [page 149](#) for channel number derivation.

Example: Closing and opening Analog Bus relays The following command connects the analog buses to Matrix 2 (2-wire mode).

```
ROUTE:CLOSE (@1921,1922,1923,1924)
```

```
ROUTE:OPEN (@1921,1922,1923,1924)
```

NOTE

For 2-wire mode, only Matrix 2 connects to the the analog buses. In 1-wire mode, only Matrix 3 and Matrix 4 connect to the analog buses.

The analog bus relays (numbered 1921, 1922, 1923, 1924) on the L4433A are ignored if they are included in a range of channels. An error will be generated if an analog bus relay is specified as the first or last channel in a range of channels. For example, the following command closes all valid channels between channel 1504 and channel 1708. In addition, this command closes Analog Bus relay 1921. Note that although the specified range of channels includes the other Analog Bus relays, they are ignored and are not closed by this command.

```
ROUTE:CLoSe (@1504:1708,1921)
```

Example: Querying channels for open or close state The following command returns a 1 (true) or 0 (false) state of channel 204.

```
ROUTE:CLoSe (@1204)
```

```
ROUTE:CLoSe? (@1204) !Returns a 1
```

```
ROUTE:OPeN? (@1204) !Returns a 0
```

Example: Querying the system for module Identify The following command returns the identity of the L4433A:

```
SYSTem:CTYPe? 1
```

NOTE

For the L4433A, the query response may include a suffix to indicate a 1-wire configuration. For example, the response for the L4433A will be either "L4433A" (2-wire mode) or "L4433A-1W" (1-wire mode).

Reading Cycle Count and Resetting the Power-On State

Example: Reading the cycle count for a relay The following command returns the cycle count on channels 304 and 308.

```
DIAGnostic:RELay:CYCLes? (@1304,1308)
```

Example: Resetting the power-on state The following command sets the L4433A to its power-on state.

```
SYSTem:CPON 1
```

Linking Multiple L4433A Instruments

You can link multiple L4433A instruments to form a larger matrix. The following two drawings show two-module connections through rows and columns.

You can connect rows in separate instruments using external wiring. Or, using Bank 2 matrices, you can connect through the analog busses. For a clear idea of how matrices are arranged and their connections to the analog busses, see the simplified schematics later in this chapter. You must use external wiring whenever you connect:

- rows in Matrix 1 of separate modules
- rows in Matrix 1 to rows in Matrix 2 on the same or separate modules
- columns of two matrices on the same or separate modules

Note that the presence of in-rush resistors on the analog busses and columns require additional consideration, and you must take care when linking multiple L4433As. See the simplified schematics on [page 156](#) and [page 160](#).

L4433A Dual/Quad 4x8 Reed Matrix Hardware Description

You can configure the L4433A dual/quad 4x8 reed matrix for 2-wire (differential) mode or 1-wire (single-ended) mode.

The L4433A contains 100 Ω in-rush resistors that are used to protect the reed relays from reactive loads. If you have applications where in-rush resistors interfere with measurements, connections are provided on the terminal blocks for you to bypass the in-rush resistors that are located on the columns. See the simplified schematics on [page 156](#) and [page 160](#). However, if you choose to bypass the in-rush resistors, the life of the reed relays that you bypass may be degraded.

Two-Wire Mode

To physically configure the module for 2-wire mode, use the 34933T-001 terminal block, or a compatible standard or custom cable. If using a standard or custom cable, make sure you connect interlock pins 17 and 33 on the Matrix 2 D-sub connector. Refer to the pinout drawing and table on [page 157](#).

In 2-wire mode, the L4433A module contains two matrices, each with 32 2-wire crosspoint non-latching reed relays organized in a 4-row by 8-column configuration. Every row and column are made up of two wires each, a high (H) and a low (L). Each crosspoint relay has a unique channel number representing the row and column that intersect to create the crosspoint. For example, channel 308 represents the crosspoint connection between row 3 and column 08 (all columns consisting of two digits; in this case the digits are 08). See the simplified schematic on [page 156](#).

You can connect any combination of inputs and outputs at the same time. However, only Matrix 2 in 2-wire mode of this module connects to the analog buses. By closing channels 921 and 922 you can connect rows 5 and 6 respectively to the HI (H) and LO (L) lines of ABus1 and ABus2.

In 2-wire mode, you can close no more than 20 channels simultaneously due to power dissipation. However, note that analog bus relays count half as much as channel relays in that total. For example, with one analog bus relay closed, you can close up to a maximum of 19 channel relays. If you try to close more than the allowed number of channels, you will receive an error message.

One-Wire Mode

To physically configure the module in 1-wire mode, use the 34933T-002 terminal block, or a compatible standard or custom cable. If using a standard or custom cable, make sure you connect interlock pins 17 and 33 on the Matrix 2 D-sub connector. Refer to the pinout drawing and table on [page 161](#).

In 1-wire mode, the L4433A module contains four matrices (1 through 4), each with 32 1-wire crosspoint non-latching reed relays organized in a 4-row by 8-column configuration. Every row and column has one wire each. Each crosspoint relay has a unique channel number representing the matrix, and the single-wire row and column that intersect to make the crosspoint. For example, channel 218 represents Matrix 2, row 1 and column 8. See the simplified schematic on [page 160](#).

In 1-wire mode, you can close no more than 40 channels simultaneously due to power dissipation. For example, with one analog bus relay closed you can close up to a maximum of 39 channel relays. If you try to close more than the allowed number of channels, you will receive an error message.

You can connect any combination of inputs and outputs at the same time. However, only Matrix 3 and Matrix 4 in 1-wire mode of this module connect to the analog buses. By closing channels 921 and 922 you can connect row 1 and row 2 respectively to the HI (H) and LO (L) lines of ABus1 and ABus2.

You can connect multiple matrix modules externally and/or through the analog buses for applications that require large matrices. For information on linking multiple matrix modules, refer to [page 152](#) of this chapter.

When the power is off, matrix relays and analog bus relays open.

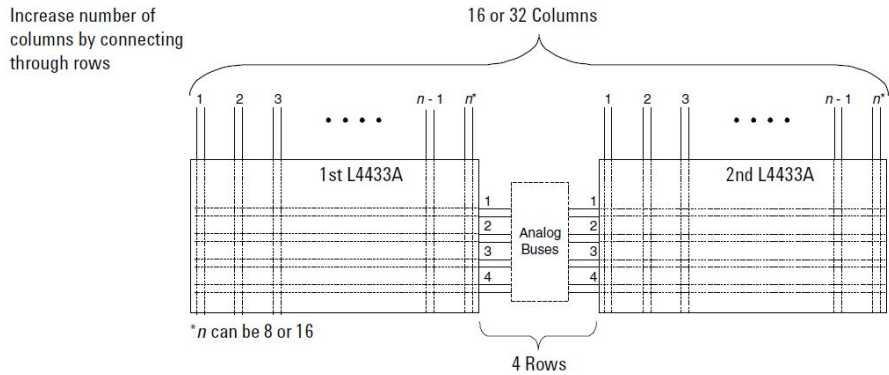
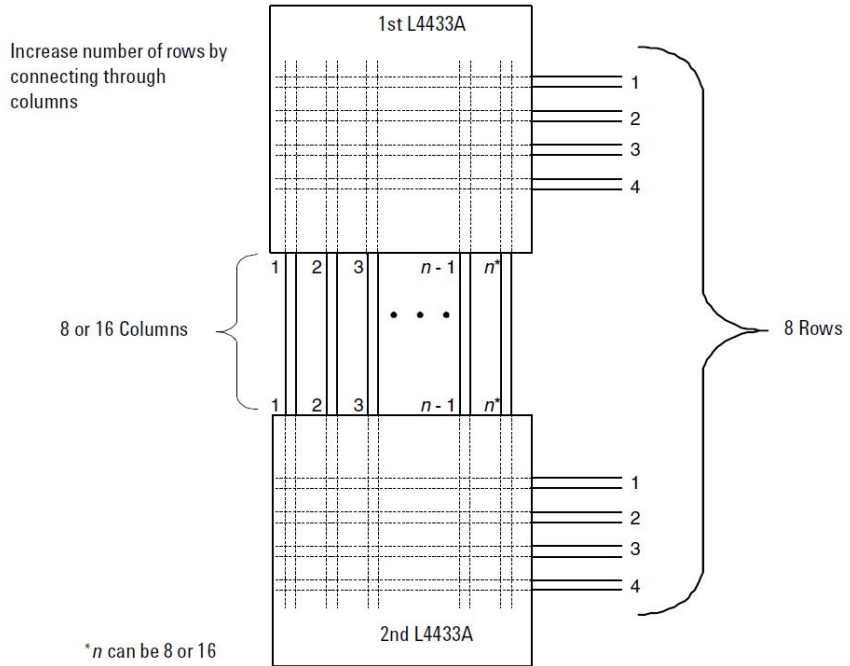

L4433A Simplified Schematic for Two-Wire Mode

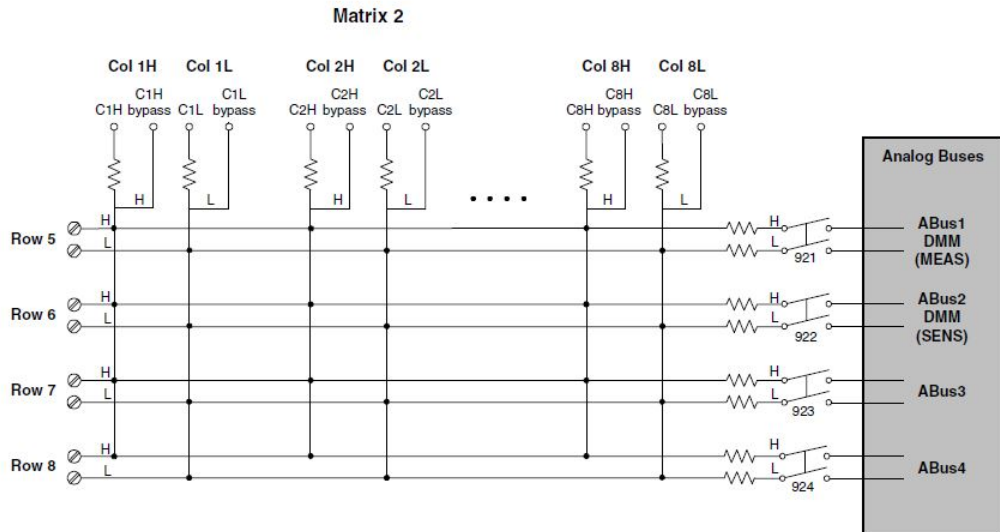
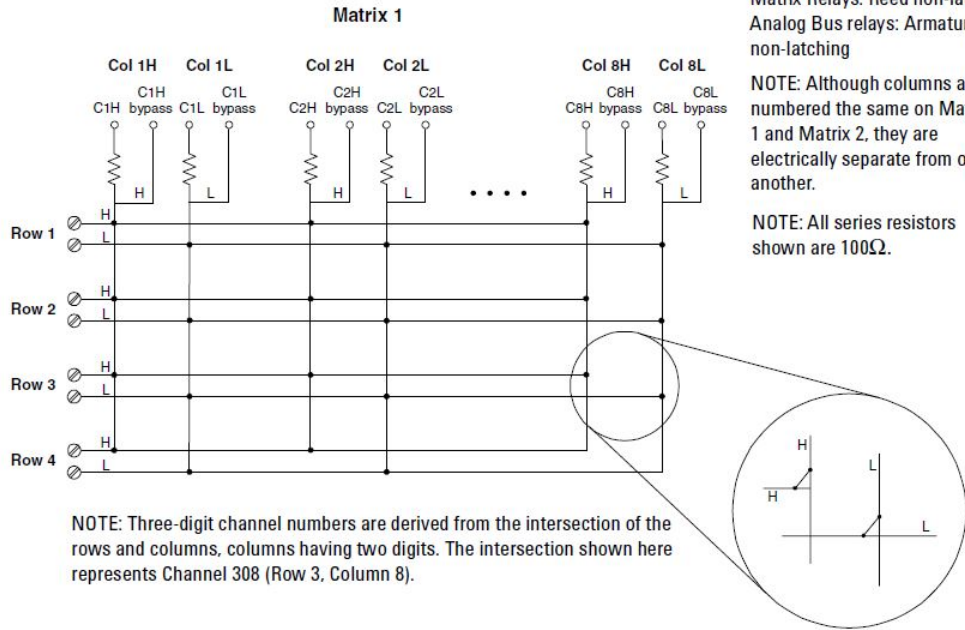

L4433A D-Sub Connectors for Two-Wire Mode

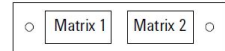

Matrix 1

For orientation, the D-sub connector end of the module is facing you.

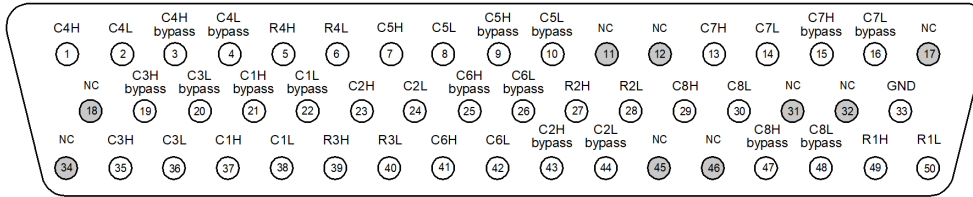

NOTE:
-In this diagram and the table below, R represents "row," and C represents "column."
-Bypass" means to bypass the 100 Ω in-rush resistor that protects the reed relays.

50-Pin D-Sub Male Connector

Description	Pin	Description	Pin	Description	Pin	Description	Pin	Description	Pin	Description	Pin
R1H	49	C1H	37	C5H	7	C1H bypass	21	C5H bypass	9	GND	33
R1L	50	C1L	38	C5L	8	C1L bypass	22	C5L bypass	10	No Connect pins: 11-12, 17-18, 31-32, 34, and 45-46	
R2H	27	C2H	23	C6H	41	C2H bypass	43	C6H bypass	25		
R2L	28	C2L	24	C6L	42	C2L bypass	44	C6L bypass	26		
R3H	39	C3H	35	C7H	13	C3H bypass	19	C7H bypass	15		
R3L	40	C3L	36	C7L	14	C3L bypass	20	C7L bypass	16		
R4H	5	C4H	1	C8H	29	C4H bypass	3	C8H bypass	47		
R4L	6	C4L	2	C8L	30	C4L bypass	4	C8L bypass	48		

Matrix 2

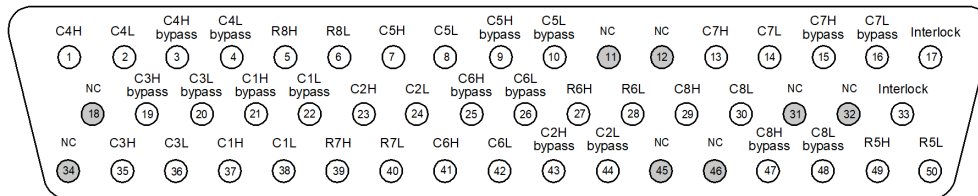

NOTE:
-In this diagram and the table below, R represents "row," and C represents "column."
-Bypass" means to bypass the 100 Ω in-rush resistor that protects the reed relays.

50-Pin D-Sub Male Connector

WARNING As a safety feature, interlock pins (17 and 33) must be shorted to enable the analog bus relays, which are on Matrix 2, to close. The optional 34933T-001 (for 2-wire) terminal block shorts these pins for you. This feature protects inadvertent routing of high voltages from the analog bus to the D-sub connector of the module.

Description	Pin	Description	Pin	Description	Pin	Description	Pin	Description	Pin
R5H	49	C2H	23	C7H	13	C4H bypass	3	Interlock	17
R5L	50	C2L	24	C7L	14	C4L bypass	4	Interlock	33
R6H	27	C3H	35	C8H	29	C5H bypass	9	No Connect pins: 11-12, 18, 31-32, 34, and 45-46	
R6L	28	C3L	36	C8L	30	C5L bypass	10		
R7H	39	C4H	1	C1H bypass	21	C6H bypass	25		
R7L	40	C4L	2	C1L bypass	22	C6L bypass	26		
R8H	5	C5H	7	C2H bypass	43	C7H bypass	15		
R8L	6	C5L	8	C2L bypass	44	C7L bypass	16		
C1H	37	C6H	41	C3H bypass	19	C8H bypass	47		
C1L	38	C6L	42	C3L bypass	20	C8L bypass	48		

34933T-001 Terminal Block for Two-Wire Mode

This terminal block with screw-type connections is labeled with the model number and the abbreviated module name.

NOTE

All modules that connect to the analog bus are interlock protected. This means that when an installed module is exposed (no terminal block or cable is connected), the analog bus relays, which are on Matrix 2, are open and disconnected from the analog buses. See [page 146](#) for further information.

NOTE

If you are using a Keysight terminal block to connect your DUT to this module be sure to use the 34933T-001 terminal block that corresponds to the 2-wire configuration mode. Note that an error will not be generated if you have installed a terminal block that doesn't match the present module configuration.

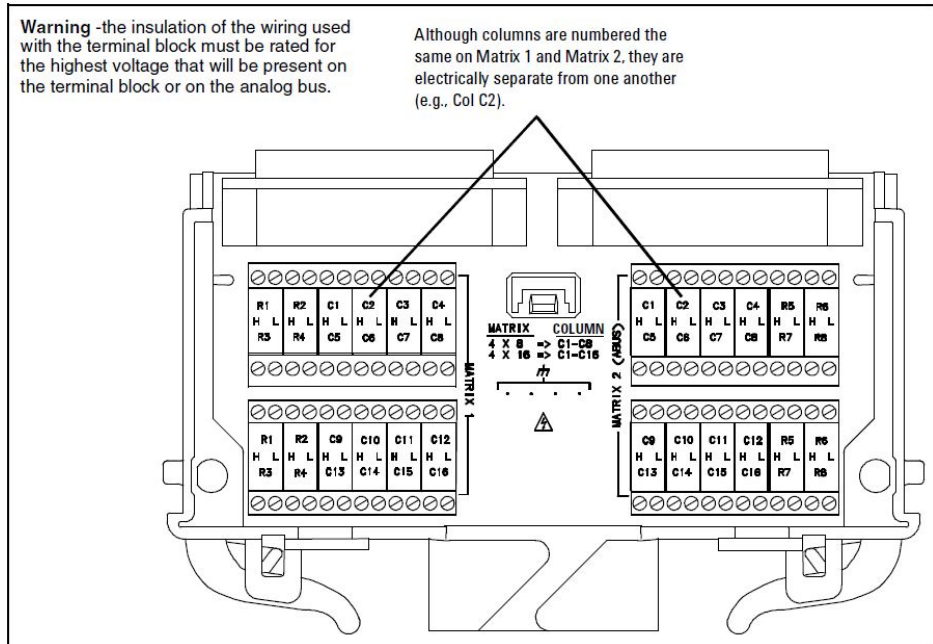

When using the 34933T terminal block for 2-wire mode, access is provided to the bypass columns through the columns labeled C9 through C16. Follow this wiring convention shown in the table below for both matrices.

Terminal marked...	Connects to...	Terminal marked...	Connects to...
C9H	C1H bypass	C13H	C5H bypass
C9L	C1L bypass	C13L	C5L bypass
C10H	C2H bypass	C14H	C6H bypass
C10L	C2L bypass	C14L	C6L bypass
C11H	C3H bypass	C15H	C7H bypass
C11L	C3L bypass	C15L	C7L bypass
C12H	C4H bypass	C16H	C8H bypass
C12L	C4L bypass	C16L	C8L bypass

L4433A Simplified Schematic for One-Wire Mode

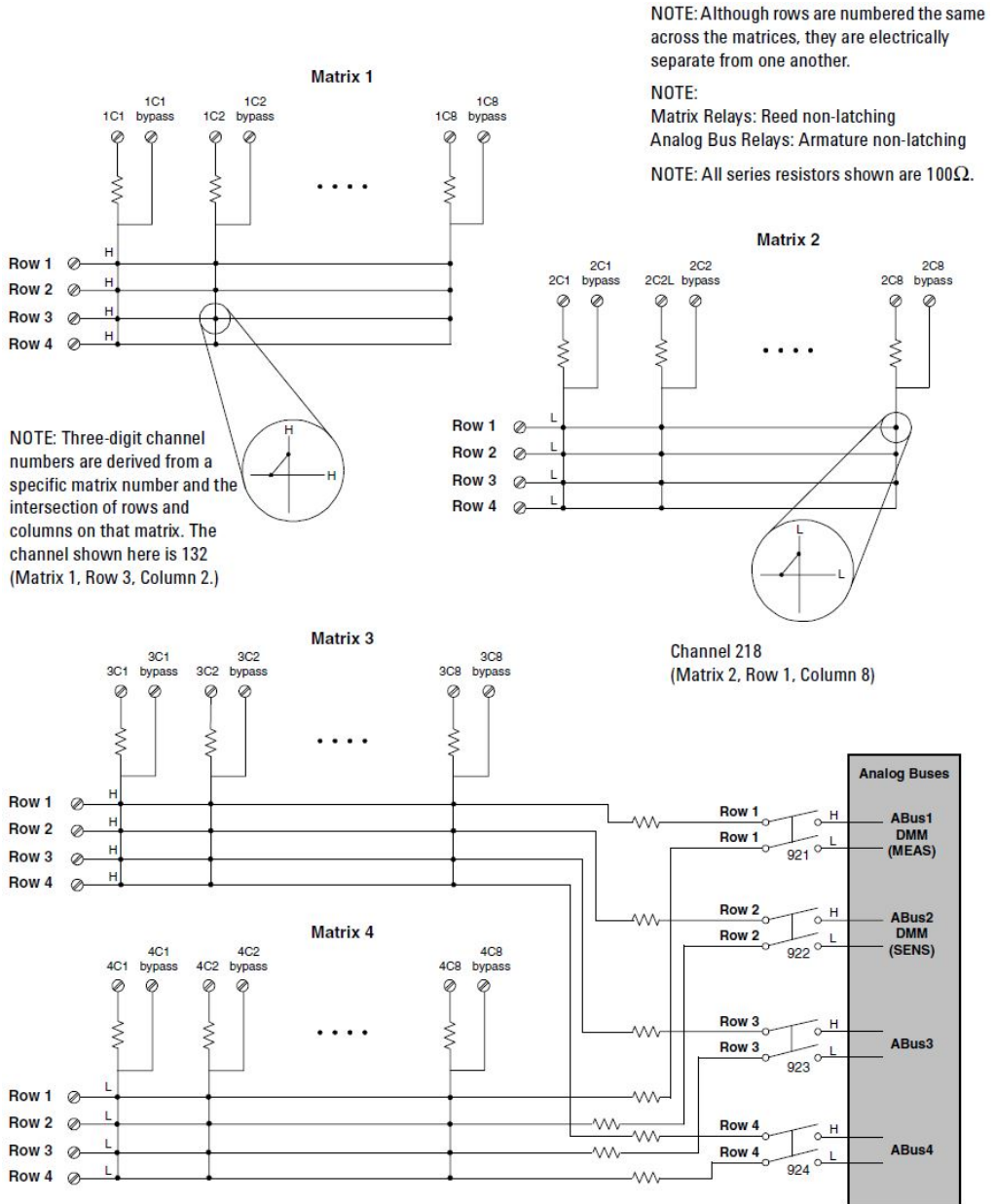

L4433A D-Sub Connectors for One-Wire Mode

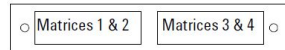

Matrices 1 and 2

For orientation, the D-sub connector end of the module is facing you.

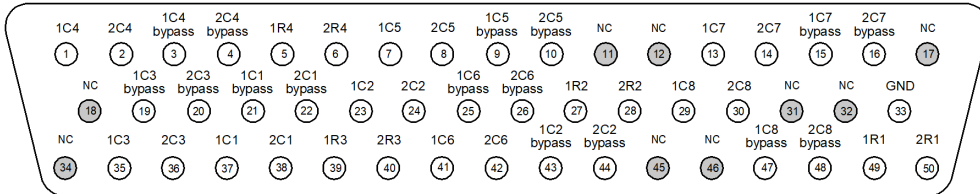

50-Pin D-Sub Male Connector

NOTE:

Conventions for these drawings and tables as they relate to pinout information:
 -2R4 means Matrix 2, Row 4.
 -1C5 means Matrix 1, Column 5.
 -4C2 bypass means: Matrix 4, Column 2, and the connection bypasses the 100 Ω in-rush resistor that protects the reed relays

Description	Pin	Description	Pin	Description	Pin	Description	Pin	Description	Pin
1R1	49	1C2	23	1C7	13	1C4 bypass	3	GND	33
1R2	27	2C2	24	2C7	14	2C4 bypass	4	No connect pins: 11-12, 17-18, 31-32, 34, and 45-46	
1R3	39	1C3	35	1C8	29	1C5 bypass	9		
1R4	5	2C3	36	2C8	30	2C5 bypass	10		
2R1	50	1C4	1	1C1 bypass	21	1C6 bypass	25		
2R2	28	2C4	2	2C1 bypass	22	2C6 bypass	26		
2R3	40	1C5	7	1C2 bypass	43	1C7 bypass	15		
2R4	6	2C5	8	2C2 bypass	44	2C7 bypass	16		
1C1	37	1C6	41	1C3 bypass	19	1C8 bypass	47		
2C1	38	2C6	42	2C3 bypass	20	2C8 bypass	48		

Matrices 3 and 4

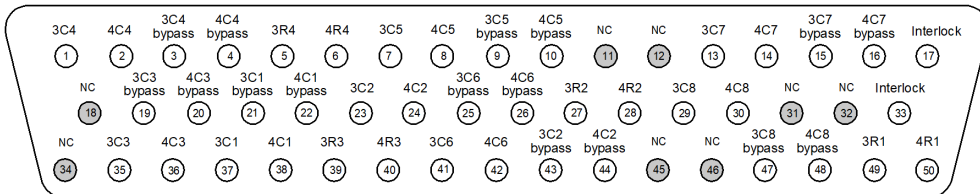

50-Pin D-Sub Male Connector

WARNING As a safety feature, interlock pins (17 and 33) must be shorted to enable the analog bus relays, which are on Matrix 2, to close. The optional 34933T-002 (for 1-wire) terminal block shorts these pins for you. This safety feature protects inadvertent routing of high voltages from the analog buses to the D-sub connector of the module.

Description	Pin	Description	Pin	Description	Pin	Description	Pin	Description	Pin
3R1	49	3C2	23	3C7	13	3C4 bypass	3	Interlock	17
3R2	27	4C2	24	4C7	14	4C4 bypass	4	Interlock	33
3R3	39	3C3	35	3C8	29	3C5 bypass	9	No connect pins: 11-12, 18, 31-32, 34, and 45-46	
3R4	5	4C3	36	4C8	30	4C5 bypass	10		
4R1	50	3C4	1	3C1 bypass	21	3C6 bypass	25		
4R2	28	4C4	2	4C1 bypass	22	4C6 bypass	26		
4R3	40	3C5	7	3C2 bypass	43	3C7 bypass	15		
4R4	6	4C5	8	4C2 bypass	44	4C7 bypass	16		
3C1	37	3C6	41	3C3 bypass	19	3C8 bypass	47		
4C1	38	4C6	42	4C3 bypass	20	4C8 bypass	48		

34933T-002 Terminal Block for One-Wire Mode

This terminal block with screw-type connections is labeled with the model number and the abbreviated module name.

NOTE

All modules that connect to the analog bus are interlock protected. This means that when an installed module is exposed (no terminal block or cable is connected), the analog bus relays and current channels are open and disconnected from the analog buses. See [page 146](#) for further information.

NOTE

If you are using a Keysight terminal block to connect your DUT to this module be sure to use the 34933T-002 terminal block that corresponds to the 1-wire configuration mode. Note that an error will not be generated if you have installed a terminal block that doesn't match the present module configuration.

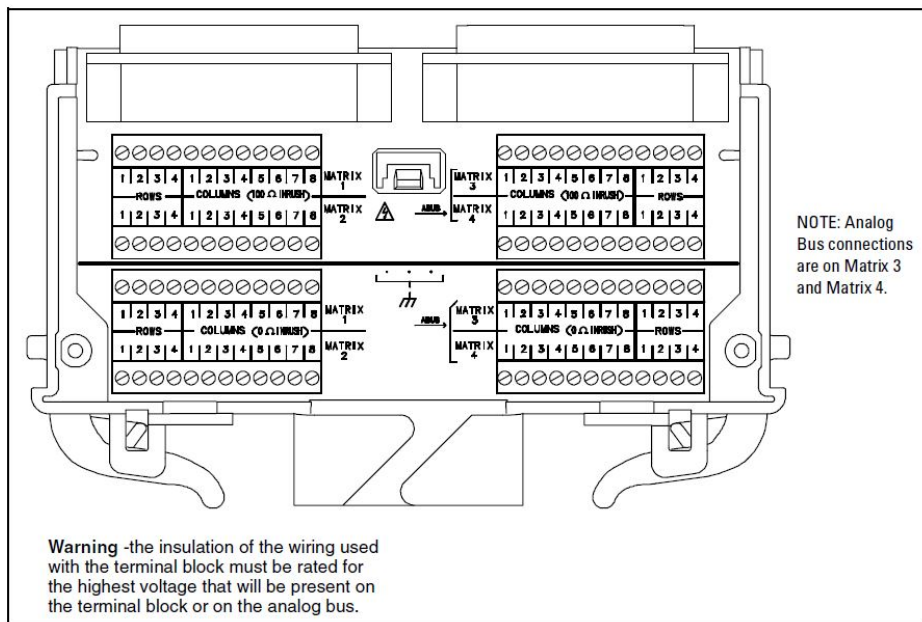

6 L4437A General Purpose Switch

General Purpose Switch Instrument	164
L4437A SCPI Command Summary	166
L4437A Example Program Segments	168
L4437A 32-Channel General Purpose Switch Hardware Description	170

General Purpose Switch Instrument

The L4437A General Purpose (GP) switch can be used to route signals or control other system devices.

- The L4437A provides independent control of 32 latching relays:
 - Twenty-eight Form C relays rated for 1 A at 60 W per channel
 - Four Form A relays rated for 5 A at 150 W per channel.

The L4437A contains armature-latching relays, and you can use the switch for device actuation, digital output, or combine it with additional switch instruments to create flexible switching topologies. You can close multiple channels at the same time. The L4437A does not implement an analog bus.

A temperature sensor on the instrument triggers system interrupts when high-carry current-induced heat on the instrument is excessive. This over-temperature situation generates an SRQ event when the factory-set 70°C threshold is reached. It is up to the user to determine what, if any, action should be taken.

Reactive loads (those that include significant inductance or capacitance) can cause voltage spikes or current spikes during switching operations. The L4437A is designed for switching reactive loads. The optional 34937T terminal block has solder pads for adding snubber circuits for the 5 A relays to reduce the reactive transients. See the drawings on [page 172](#) for the locations of snubber circuit pads and installation information about a snubber circuit.

A hardware jumper on the L4437A allows you to define the power-failure states for the instrument's 5 A latching relays. Depending on the position of the jumper, the 5 A relays will either open or maintain state when system power failure occurs. When shipped from the factory, the power-fail jumper is in "MAINTAIN" position (all relays maintain their present state when power fails).

WARNING

Before changing the position of the jumper, turn off the instrument and remove all external connections. Wait five to ten seconds to allow the instrument's internal capacitors to discharge.

Remove the L4437A instrument sub-assembly from the instrument carrier and then remove the sheet metal cover from the sub-assembly. Move the position of

the jumper mounted on the sub-assembly. See the figure below for the jumper's location.

WARNING

Do not connect the L4437A directly to a mains power outlet. If it is necessary to switch a mains voltage or any circuit where a large inductive load may be switched, you must add signal conditioning elements to reduce the potential transients before they reach the instrument.

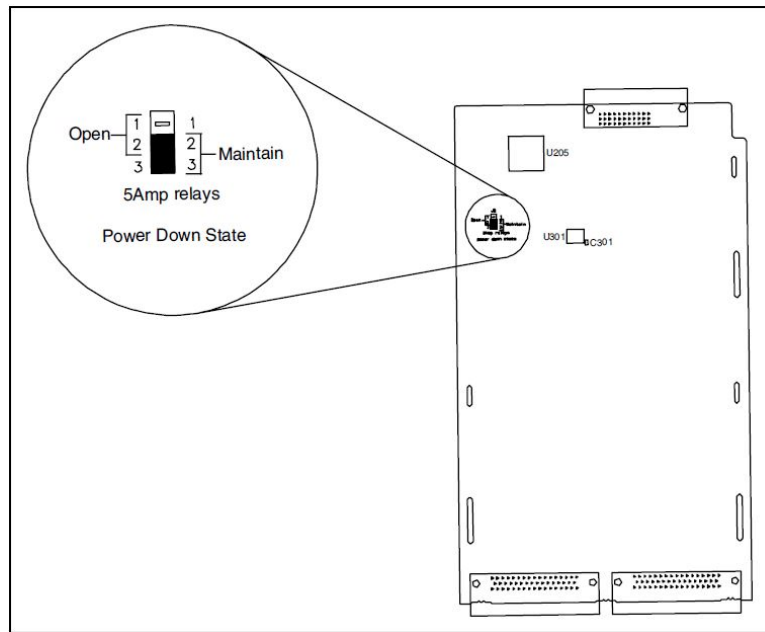

Figure 6-1 5A Relay Power-Down State Jumper.

L4437A SCPI Command Summary

Table 6-1 lists the instrument-specific SCPI commands that apply to the L4437A General Purpose Switch Instrument. Table 3-3 (Chapter 3) lists the SCPI commands that apply to all L4400 series instruments.

For complete information on all SCPI commands, refer to the Programmer's Reference at www.keysight.com/find/L4400.

Table 6-1 L4437A SCPI Command Summary.

Subsystem	Commands
ROUTE (Switch Control)	ROUTe:CHANnel:LABel:CLEar:MODule 1
	ROUTe:CHANnel:LABel[:DEFine] "<label>" , (@<ch_list>)
	ROUTe:CHANnel:LABel[:DEFine]? [{USER FACTory},] (@<ch_list>)"
	ROUTe:CLOSe (@<ch_list>)
	ROUTe:CLOSe? (@<ch_list>)
	ROUTe:CLOSe:EXCLusive (@<ch_list>)
	ROUTe:MODule:BUSY? 1
	ROUTe:MODule:WAIT 1
	ROUTe:MODule:WAIT? 1
	ROUTe:OPEN (@<ch_list>)
	ROUTe:OPEN? (@<ch_list>)
	ROUTe:OPEN:ALL 1
	ROUTe[:OPERation]:OVERlap[:ENABLE] {OFF 0 ON 1}
	ROUTe[:OPERation]:OVERlap[:ENABLE]?

Subsystem	Commands
ROUTE (Sequence Operation)	ROUTe:SEQuence:ABORt ROUTe:SEQuence:BUSY? ROUTe:SEQuence:CATalog? ROUTe:SEQuence:DEFine <name>, "<commands>" ROUTe:SEQuence:DEFine? <name> ROUTe:SEQuence:DELeTe:ALL ROUTe:SEQuence:DELeTe[:NAME] <name> ROUTe:SEQuence:RU NNing:NAME? ROUTe:SEQuence:TRIGGer[:IMMediate] <name> ROUTe:SEQuence:TRIGGer:SOURce <name>, MANual ROUTe:SEQuence:TRIGGer:SOURce? <name> ROUTe:SEQuence:WAIT
DIAGnostic	DIAGnostic:RELAy:CYCLes? (@<ch_list>) DIAGnostic:RELAy:CYCLes:CLEar (@<ch_list>)
SYSTEM	SYSTem:MODule:PFAil:JUMPer:AMP5? 1 SYSTem:MODule:TEMPerature? [{TRANsducer TTHReshold}], 1

L4437A Example Program Segments

The following sections contain example program segments of commonly used instrument functions.

The channel addressing scheme used in these segments follow the form 1ccc where ccc is the channel number.

For detailed example programs involving multiple drivers and development environments, refer to the example programs for the L4400 Series on www.keysight.com/find/L4400.

Opening and Closing Channels

Example: Closing and opening channels The first two commands close channel 3, then channel 5. The last command opens both channel 3 and channel 5.

```
ROUTE:CL0Se (@1003)
ROUTE:CL0Se (@1005)
ROUTE:OPEN (@1003,1005)
```

Example: Querying channels for open or close state The following command returns a 1 (true) or 0 (false) state of channel 016.

```
ROUTE:CL0Se (@1016)
ROUTE:CL0Se? (@1016) !Returns a 1
ROUTE:OPEN? (@1016) !Returns a 0
```

Reading Jumper State and System Identity

Example: Querying the power-failure state of 5 A relays The following command returns the position of the power-fail jumper, either “MAIN” (all relays maintain their present state when power fails) or “OPEN” (all relays open when power fails). If this command is sent to a module other than the L4437A, “NONE” is returned (no error is generated).

```
SYSTem:MODUle:PFAl:JUMPer:AMP5? 1
```

Example: Querying the system for module identify The following command returns the identify of the instrument.

```
SYSTem:CTYPe? 1
```

Reading Cycle Count and Resetting Modules to Power-On State

Example: Reading the cycle count for a relay The following command returns the relay cycle count on channel 7 and channel 16.

```
DIAGnostic:RELAy:CYCLes? (@1007,1016)
```

Example: Clearing the cycle count for a relay (all switch modules) The following command resets the relay cycle count on channels 7 and 16.

```
DIAGnostic:RELAy:CYCLes:CLEAr (@1007,1016)
```

Example: Resetting the Instrument to its power-on state The following command resets the instrument to its power-on state.

```
SYSTem:CPON 1
```

L4437A 32-Channel General Purpose Switch Hardware Description

The L4437A general-purpose switch provides independent control of:

- Twenty-eight Form C (DPST) latching relays rated at 1 A
- Four Form A (SPST) latching relays rated at 5 A. You can set the power-failure state for these 5 A relays. See [page 164](#) and [page 165](#).

NOTE

A temperature sensor on these modules triggers system interrupts when high-carry current-induced heat on the modules reaches a threshold of 70°C.

L4437A Simplified Schematic

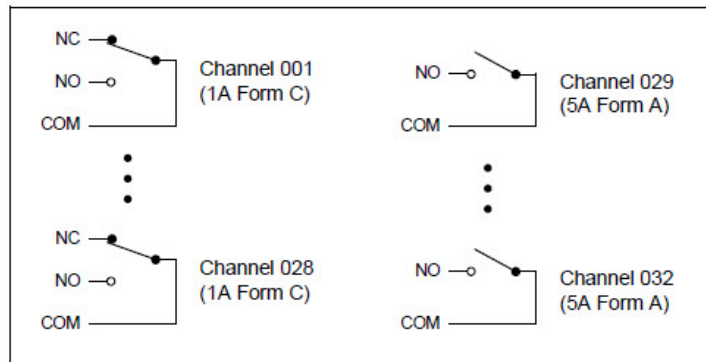

L4437A D-Sub Connectors

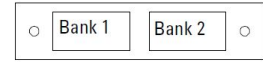

Bank 1

For orientation, the D-sub connector end of the module is facing you.

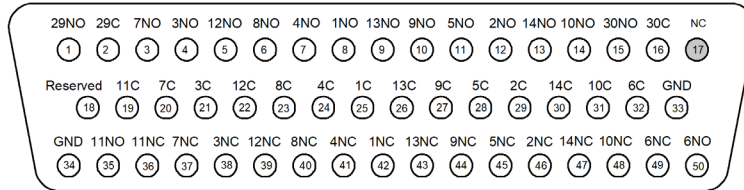

50-Pin D-Sub Male Connector

Channel	Pin	Channel	Pin	Channel	Pin	Channel	Pin	Channel	Pin		
1 NC	42	4 NC	41	7 NC	37	10 NC	48	13 NC	43	30 NO	15
1 Common	25	4 Common	24	7 Common	20	10 Common	31	13 Common	26	30 Common	16
1 NO	8	4 NO	7	7 NO	3	10 NO	14	13 NO	9	Reserved	18
2 NC	46	5 NC	45	8 NC	40	11 NC	36	14 NC	47	GND	33
2 Common	29	5 Common	28	8 Common	23	11 Common	19	14 Common	30	GND	34
2 NO	12	5 NO	11	8 NO	6	11 NO	35	14 NO	13	No Connect	17
3 NC	38	6 NC	49	9 NC	44	12 NC	39	29 NO	1		
3 Common	21	6 Common	32	9 Common	27	12 Common	22	29 Common	2		
3 NO	4	6 NO	50	9 NO	10	12 NO	5				

Bank 2

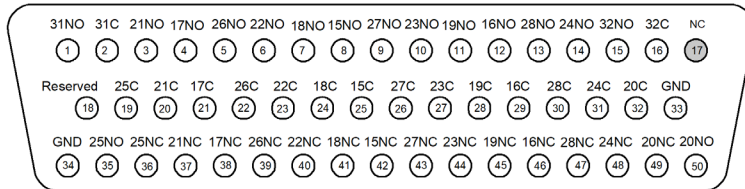

50-Pin D-Sub Male Connector

Channel	Pin	Channel	Pin	Channel	Pin	Channel	Pin	Channel	Pin		
15 NC	42	18 NC	41	21 NC	37	24 NC	48	27 NC	43	32 NO	15
15 Common	25	18 Common	24	21 Common	20	24 Common	31	27 Common	26	32 Common	16
15 NO	8	18 NO	7	21 NO	3	24 NO	14	27 NO	9	Reserved	18
16 NC	46	19 NC	45	22 NC	40	25 NC	36	28 NC	47	GND	33
16 Common	29	19 Common	28	22 Common	23	25 Common	19	28 Common	30	GND	34
16 NO	12	19 NO	11	22 NO	6	25 NO	35	28 NO	13	No Connect	17
17 NC	38	20 NC	49	23 NC	44	26 NC	39	31 NO	1		
17 Common	21	20 Common	32	23 Common	27	26 Common	22	31 Common	2		
17 NO	4	20 NO	50	23 NO	10	26 NO	5				

34937T Terminal Block

This terminal block with screw-type connections is labeled with the model number and the abbreviated module name.

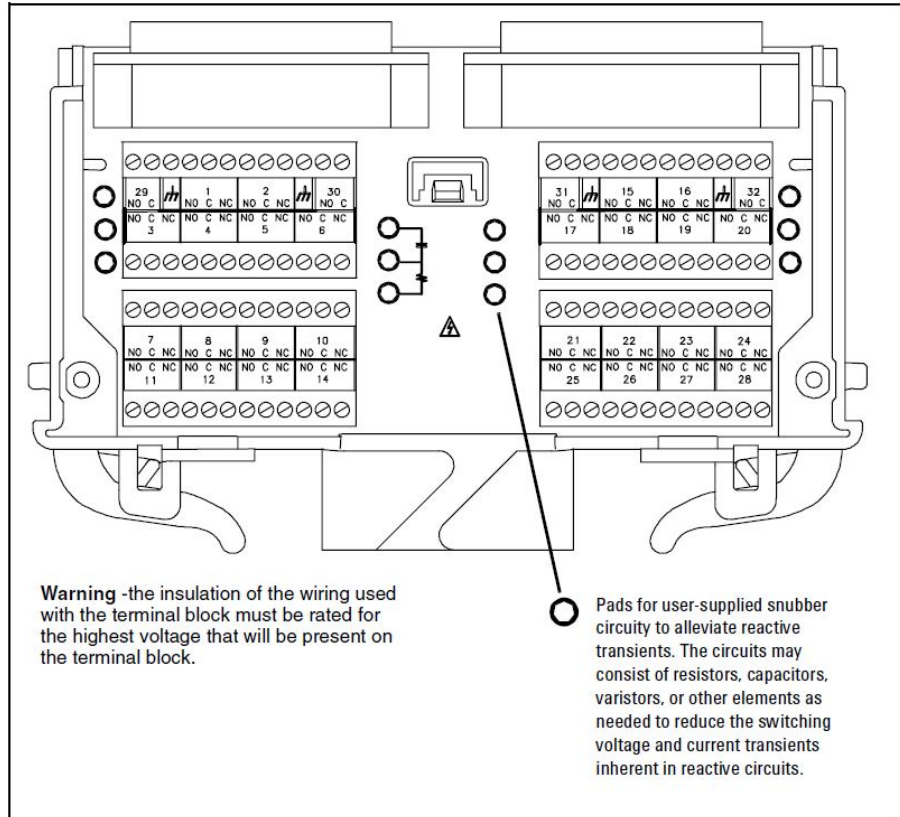

Figure 6-2 L4437A Terminal Block.

7 L4445A Microwave Switch/ Attenuator Driver

L4445A SCPI Command Summary	174
L4445A Microwave Switch/Attenuator Driver	177
Recommended Switches and Attenuators	180
Power Supplies	181
Channel Numbering	183
Simple Switch Control	184
Remote Module Identifiers	185
Drive Modes	186
Using Single Drive Switches and Attenuators	186
Using Dual Drive Switches and Attenuators	187
Using Pulse Drive	188
Long Execution Times	190
Verifying Switch State	190
LED Drive	192
Default and Reset States	192
Distribution Boards	195
Mounting the Remote Modules	225
SCPI Programming Examples	227

L4445A SCPI Command Summary

Table 7-1 lists the instrument-specific SCPI commands that apply to the L4445A Microwave Switch / Attenuator Driver Instrument. Table 3-3 (Chapter 3) lists the SCPI commands that apply to all L4400 series instruments.

For complete information on all SCPI commands, refer to the Programmer's Reference at www.keysight.com/find/L4400.

Table 7-1 L4445A SCPI Command Summary.

Subsystem	Commands
ROUTe (Switch Control)	ROUTe:CHANnel:DRIVE:CLOSe:DEFault (@<ch_list>)
	ROUTe:CHANnel:DRIVE:CLOSe:DEFault? (@<ch_list>)
	ROUTe:CHANnel:DRIVE:OPEN:DEFault (@<ch_list>)
	ROUTe:CHANnel:DRIVE:OPEN:DEFault? (@<ch_list>)
	ROUTe:CHANnel:DRIVE:PAIRed[:MODE] {OFF 0 ON 1}, (@<ch_list>)
	ROUTe:CHANnel:DRIVE:PAIRed[:MODE]? (@<ch_list>)
	ROUTe:CHANnel:DRIVE:PULSe[:MODE] {OFF 0 ON 1}, (@<ch_list>)
	ROUTe:CHANnel:DRIVE:PULSe[:MODE]? (@<ch_list>)
	ROUTe:CHANnel:DRIVE:PULSe:WIDTh {<seconds> MIN MAX DEF}, (@<ch_list>)
	ROUTe:CHANnel:DRIVE:PULSe:WIDTh? [{MIN MAX},] (@<ch_list>)
	ROUTe:CHANnel:DRIVE:STATe? (@<ch_list>)
	ROUTe:CHANnel:DRIVE:TIME:RECOvery {<seconds> MIN MAX DEF}, (@<ch_list>)
	ROUTe:CHANnel:DRIVE:TIME:RECOvery? [{MIN MAX},] (@<ch_list>)
	ROUTe:CHANnel:DRIVE:TIME:SETTle {<seconds> MIN MAX DEF}, (@<ch_list>)
	ROUTe:CHANnel:DRIVE:TIME:SETTle? [{MIN MAX},] (@<ch_list>)
	ROUTe:CHANnel:LAbel:CLear:MODule 1
	ROUTe:CHANnel:LAbel[:DEFine] "<label>" , (@<ch_list>)
	ROUTe:CHANnel:LAbel[:DEFine]? [<type> ,] (@<ch_list>)
	ROUTe:CHANnel:VERify[:ENABle] {OFF 0 ON 1}, (@<ch_list>)
	ROUTe:CHANnel:VERify[:ENABle]? (@<ch_list>)
ROUTe:CHANnel:VERify:POLarity {NORMal INVerted}, (@<ch_list>)	

Subsystem	Commands
	ROUTe:CHANnel:VERify:POLarity? (@<ch_list>)
	ROUTe:CHANnel:VERify:POSition:STATe? (@<ch_list>)
	ROUTe:CLOSe (@<ch_list>)
	ROUTe:CLOSe? (@<ch_list>)
	ROUTe:MODule:BUSY? 1
	ROUTe:MODule:WAIT 1
	ROUTe:MODule:WAIT? 1
	ROUTe:OPeN (@<ch_list>)
	ROUTe:OPeN? (@<ch_list>)
	ROUTe:OPeN:ALL 1
	ROUTe:OPeRation:OVerlap[:ENABle] {OFF 0 ON 1}
	ROUTe:OPeRation:OVerlap[:ENABle]?
	ROUTe:RMODule:BAntenna:DRIVE[:MODE] {TTL OCOLlector}, {1-4 BANK1-BANK4 ALL}, (@<rem_ch_list>)
	ROUTe:RMODule:BAntenna:DRIVE[:MODE]? {1-4 BANK1-BANK4}, (@<rem_ch_list>)
	ROUTe:RMODule:BAntenna:LED:DRIVE[:ENABle] {OFF 0 ON 1}, {1-4 BANK1-BANK4 ALL}, (@<rem_ch_list>)
	ROUTe:RMODule:BAntenna:LED:DRIVE[:ENABle]?
	{1-4 BANK1-BANK4}, (@<rem_ch_list>)
	ROUTe:RMODule:BAntenna:LED:DRIVE:LEVel {<amps> MIN MAX DEF}, {1-4 BANK1-BANK4 ALL}, (@<rem_ch_list>)
	ROUTe:RMODule:BAntenna:LED:DRIVE:LEVel? {1-4 BANK1-BANK4}, (@<rem_ch_list>)
	ROUTe:RMODule:BAntenna:PRESet {1-4 BANK1-BANK4 ALL}, (@<rem_ch_list>)
	ROUTe:RMODule:DRIVE:LIMit {<max_drives> MIN MAX DEF}, (@<rem_ch_list>)
	ROUTe:RMODule:DRIVE:LIMit? [{MIN MAX},] (@<rem_ch_list>)
	ROUTe:RMODule:DRIVE:SOURce:BOOT {OFF INternal EXternal}, (@<rem_ch_list>)
	ROUTe:RMODule:DRIVE:SOURce:BOOT? (@<rem_ch_list>)
	ROUTe:RMODule:DRIVE:SOURce[:IMMediate] {OFF INternal EXternal}, (@<rem_ch_list>)
	ROUTe:RMODule:DRIVE:SOURce[:IMMediate]? (@<rem_ch_list>)

Subsystem	Commands
<p style="text-align: center;">ROUTE (Sequence Operation)</p>	ROUTe:SEQuence:ABORt ROUTe:SEQuence:BUSY? ROUTe:SEQuence:CATalog? ROUTe:SEQuence:DEFine <name>, "<commands>" ROUTe:SEQuence:DEFine? <name> ROUTe:SEQuence:DELete:ALL ROUTe:SEQuence:DELete[:NAME] <name> ROUTe:SEQuence:RUNNing:NAME? ROUTe:SEQuence:TRIGger[:IMMediate] <name> ROUTe:SEQuence:TRIGger:SOURce <name>, MANual ROUTe:SEQuence:TRIGger:SOURce? <name> ROUTe:SEQuence:WAIT
<p style="text-align: center;">SYSTEM</p>	SYSTem:RMOdule:RESet 1 SYSTem:RMOdule:STATus? 1

L4445A Microwave Switch/Attenuator Driver

The L4445A consists of a driver interface instrument (L4445A) and one or more remote modules (34945EXT). The first remote module is electrically attached to the driver instrument using a provided cable (equipped with 9-pin D-Sub connectors). The first remote module attached to the driver instrument is referred to as the master module. Additional remote modules are referred to as slave modules.

Additional remote modules (34945EXT) are connected in a daisy-chain fashion using RJ-45 connectors and cables. A cable is provided with each module. Up to eight remote modules can be controlled by a single L4445A.

Each remote module is divided into four banks for switch control. Each bank has a connector for a distribution board. The distribution boards provide an electrical connection between the user-supplied microwave switches or attenuators and the remote module. A variety of distribution boards are available that provide the most common connections to Keysight microwave switches and attenuators. A screw terminal distribution board is also available for other devices. A list of the available distribution boards is shown on [page 195](#). The microwave switches or attenuators and the cables connecting them to the distribution boards are not supplied with the L4445A.

The cables and the remote modules allow the microwave switches and attenuators to be located closer to the device under test. This helps to keep the signal transmission paths shorter and corresponding signal losses lower.

Microwave switches and attenuators have larger power requirements than other switch devices. The L4445A instrument is able to power 24 Volt switches or attenuators on the first (master) remote module. Additional remote modules (slaves) require an external power supply since no power is supplied through the expansion bus cable. The first (master) remote module may use either an external power supply or the L4445A to supply high power devices or devices requiring drive voltages other than 24 Volt. Each remote module has screw terminals for the external power supply connections.

[Figure 7-1](#) shows the components of the L4445A microwave switch/attenuator driver configuration. The L4445A driver is shown connected to a single 34945EXT remote module.

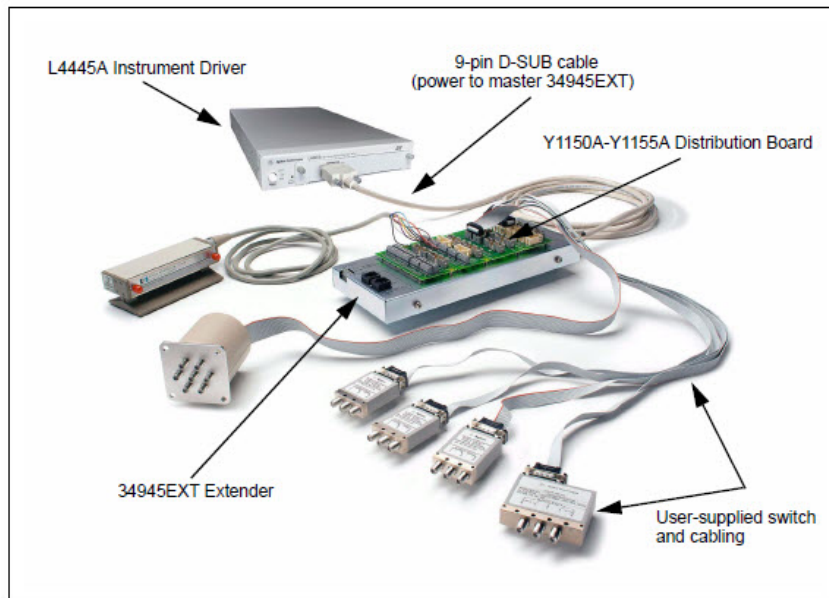

Figure 7-1 L4445A Microwave Switch / Attenuator Driver Configuration.

- Each 34945EXT module can have up to four distribution boards installed. You can have up to eight 34945EXT modules per L4445A.
- The L4445A driver interface can supply 24 V power to the first (master) remote module only. The first remote module can also use an external power source.
- Slave modules are connected in a daisy chain fashion using standard ethernet RJ-45 connectors and Cat 5 cables.
- All slave modules must obtain 24V power from an external power supply. Each module can be powered by a separate supply.
- The Cat 5 Ethernet cable must be plugged-in to port 1 on the master remote module. Port 1 and Port 2 are interchangeable on all slaves.
- All distribution boards on each remote module must use the same power supply voltage.

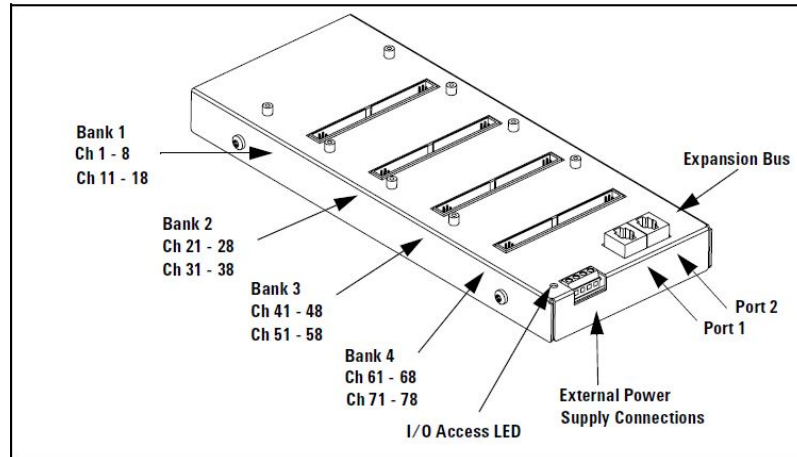

Figure 7-2 The 34945EXT Module.

Each 34945EXT has an I/O Access LED used to indicate transactions between the L4445A and the 34945EXT module. When power is first applied to a 34945EXT module, this LED is continuously illuminated.

After the module has booted, the LED illuminates only intermittently during programming operations.

Should the L4445A encounter problems communicating with the 34945EXT the LED is continuously illuminated.

LED	Meaning
Not Illuminated	Power is not applied to the module or the module is not processing commands.
Continuously Illuminated	The 34945EXT is not booted, either due to an internal error or an L4445A error.
Blinking Intermittently	Normal operation during command transactions. Send the <code>SYSTem:CTYPe:RMOduLe?</code> query to initiate a transfer and blink the LED.

NOTE

Always tighten the screws securing the L4445A sub-assembly to the instrument carrier assembly, and the screws on both ends of the D-Sub cable. Incorrect grounding can cause malfunctions of the modules due to electro-static discharge.

Recommended Switches and Attenuators

The recommended Keysight switches and attenuators for use with the L4445A are shown below. Included in the table is the distribution board used for each switch or attenuator.

Switch/Attenuator	Coil Voltage	Connection Type	Drive Options	Distribution Board
N1810UL/TL N1811TL N1812TL	Option 124 24 Vdc	Option 201 D-Sub 9-pin female	Option 402 Position Indicators	Y1150A
87104A/B/C SP4T	24 V	STD 16-pin Ribbon Cable Header	STD direct coil for open drain	Y1151A
87106A/B/C SP6T	24 V	STD 16-pin Ribbon Cable Header	STD direct coil for open drain	Y1151A
87406B 6 port matrix	24 V	STD 16-pin Ribbon Cable Header	STD direct coil for open drain	Y1151A
87204A/B/C SP4T	24 V	STD 16-pin Ribbon Cable Header	STD direct coil for open drain	Y1152A
87206A/B/C SP6T	24 V	STD 16-pin Ribbon Cable Header	STD direct coil for open drain	Y1152A
87606B 3 x 3, 2 x 4, or 1 x 5 matrix	24 V	STD 16-pin Ribbon Cable Header	STD direct coil for open drain	Y1152A

Switch/Attenuator	Coil Voltage	Connection Type	Drive Options	Distribution Board
84904K/L M 84906K/L M 849807K/L M Step Attenuators	Option 024 24 V	STD 10-pin Ribbon Cable Header		Y1153A
8494G/H 8495G/H 8496G/H Step Attenuators	Option 024 24 V	STD 12-pin Viking Connector		Y1153A
87222C/D/E Coaxial Transfer Switches	24 V	STD 10-pin Ribbon Cable Header	STD direct coil for open drain and TTL compatible	Y1154A
8762A/B/C/F 8763A/B/C 8764A/B/C	Option 024 24 V	Solder Lugs	STD direct coil for open drain	Y1155A

Power Supplies

The switches and attenuators on the master remote module can be powered from the L4445A or use an external power supply. All additional slave modules must use an external power supply.

Each remote module has a terminal strip used to connect external switch power. The three most common power supply voltages used by the microwave switches and attenuators are:

- 5 Volts
- 15 Volts
- 24 Volts (most common)

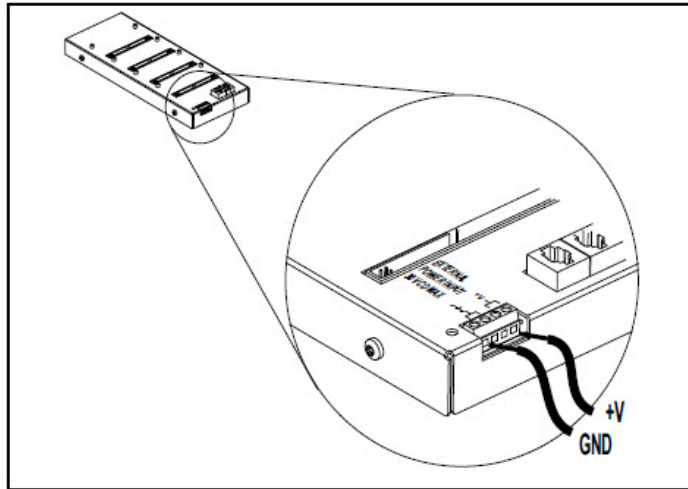

Power Consumption

Each 34945EXT can drive up to 2A continuously using an external power supply. The actual amount of power available for the switches on each 34945EXT module varies with the type of switches used.

- Some switch types consume power even in their quiescent state. Be sure to review the switch data sheets for the switches you are using.
- Set the pulse width to the minimum necessary to activate the switch using the `ROUTE:CHANne1:DRIVE:PULSe:WIDTh` command.
- Add power supply recovery time using the `ROUTE:CHANne1:DRIVE:TIMe:RECOvery` command.
- Use an external power supply if possible.
- When the source for the master remote module is set to internal, the switching current or switching and quiescent currents drawn from the internal power supply must not exceed the supply's specification of:

100mA continuous + 200mA (15ms pulse, 25% duty cycle)

For example, if the quiescent supply current required for a switch is 50mA and the switching current is 200mA, the pulse width that activates the switch must be ≤ 15 ms. To prevent an over-current condition, a 45ms delay is required before the next activation pulse occurs.

Channel Numbering

The L4445A uses the following channel numbering scheme:

1<rem><channel>

where:

rem is the remote module being controlled, and is a single digit in the range of 1 to 8.

channel is the channel number on the remote module.

The channel number is two digits spanning channels across each remote module. Channel numbers are shown below (also see [Figure 7-2](#)).

Bank	Channels	Channels
Bank 1	1 to 8	11 to 18
Bank 2	21 to 28	31 to 38
Bank 3	41 to 48	51 to 58
Bank 4	61 to 68	71 to 78

The channel numbers are arranged to facilitate the pairing of channels for dual coil switches and attenuators. Dual coil devices require the use of two channels, one for each coil. By pairing the upper and lower channels in each bank, the devices can be controlled using only the lower channel number. For example, when a paired-coil device is installed on bank 2, channels 21 and 31 are paired and are controlled using only channel 21.

The following SCPI command closes channel 5 on the master remote module connected to the L4445A.

```
ROUT:CLOS (@1105)
```

You can also use a range of channel numbers. You could close all the channels on the master remote module connected to a L4445A by sending the following command.

```
ROUT:CLOS (@1101:1178)
```

Note that when single-coil devices are used, the channel numbering is not consecutive across all 16 channels in a bank.

Simple Switch Control

All examples in this chapter make reference to SCPI commands for switch control. The L4445A commands are summarized in [Table 7-1](#). For more information, refer to the Programmer's Reference help file at www.keysight.com/find/L4400.

The switches and attenuators are designed to respond to the SCPI `ROUTe:CLOSe` and `ROUTe:OPeN` commands. For example, to open and close a switch attached to channel 1 on bank 1 of the second remote module attached to the L4445A, you could use the following commands (rem = 2, channel = 01).

```
ROUT:OPEN (@1201)
```

```
ROUT:CLOS (@1201)
```

Before you can close or open a switch, however, several other parameters must be configured. Each distribution board has a set of factory default parameters designed to support the type of switches intended to be present. These defaults are described in more detail on [page 192](#). Additionally, the drive current source must be selected and configured.

The following commands show a simple sequence controlling channel 1 of an Keysight N1810 switch (installed on a Y1150A distribution board) of the third remote module attached to a L4445A (rem = 3, channel = 01). Note that ALL 34945EXT modules are reset by the first command shown.

```
SYST:RMOD:RES 1
```

```
ROUT:RMOD:BANK:PRESET BANK1,(@1300)
```

```
ROUT:CHAN:DRIV:CLOS:DEF (@1301)
```

```
ROUT:RMOD:DRIV:SOUR INT,(@1300)
```

```
ROUT:OPEN (@1301)
```

```
<-- other commands -->
```

```
ROUT:CLOS (@1301)
```

In the example above, the `SYSTem:RMOdule:RESet` command resets the module and disables all drive currents. The next command loads the factory default settings for the distribution board (Y1150A) used to support the Keysight N1810 switch. The default state of switch closed is then configured. When the drive source is set to internal (third remote module only), the switch assumes its default closed state. The configured switch may now be controlled using the `ROUTe:OPeN` and `ROUTe:CLOSe` commands.

NOTE

You must turn off the channel drive before sending the ROUTe:RMOdule:BAnt:PRESet command. Once configured, turn the channel drive back on (ROUTe:RMOdule:DRIVE:SOURce:IMMediate).

These commands and settings are described in more detail later in this chapter and in the Programmer's Reference Help file.

Remote Module Identifiers

A special channel numbering method exists for use with SCPI commands that operate one or more banks of the remote module. This addressing uses a non-existent channel number (00) to indicate the commands are useful for all channel in a bank or all channels on a remote module. The format of this special channel list is specified as:

```
1 <rem><00>
```

where:

rem is the remote module being controlled, and is a single digit in the range of 1 to 8.

channel is non-existent channel number 00 on the remote module.

You may not use this special channel list in a range of channels.

The following commands use this form of channel addressing. Refer to the Programmer's Reference Help file for more details.

```
ROUTe:RMOdule:BAnt:DRIVE:MODE
```

```
ROUTe:RMOdule:BAnt:LED:DRIVE:ENABle
```

```
ROUTe:RMOdule:BAnt:LED:DRIVE:LEVel
```

```
ROUTe:RMOdule:BAnt:PRESet
```

```
ROUTe:RMOdule:DRIVE:LIMit
```

```
ROUTe:RMOdule:DRIVE:SOURce:BOOT
```

```
ROUTe:RMOdule:DRIVE:SOURce:IMMediate
```

Drive Modes

Each remote module can drive the switches and attenuators using either TTL or open collector drive methods. The TTL drive mode uses a pull-down resistor on the output and drives a TTL high level when asserted. The open collector drive provides a current path to ground when asserted.

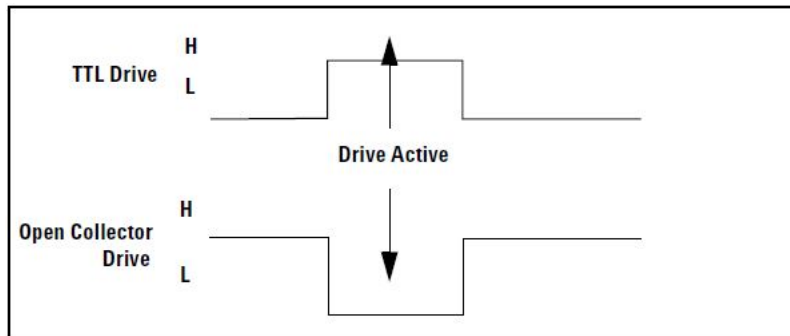

The drive mode is set on a per bank basis using the `ROUTE:RMOdule:BaNK:DRIVE:MODE` command.

Using Single Drive Switches and Attenuators

Some microwave switches require a single drive. With single drive devices the channel numbering is not consecutive across all channels in a bank (refer to the channel numbering description on [page 183](#)).

The L4445A can provide single drive devices with either pulsed or continuous drive current. Settings and parameters for continuous drive mode are given in the next section.

Continuous Drive Current

Driving non-latching devices requires a power supply capable of handling sustained high current requirements. You may only use continuous drive current with channel configured for single drive. Additionally, to prevent power supply loading, care must be taken when operating more than one continuous drive at a time. The actual drive may be configured as either TTL or open-collector operation.

Using Continuous Drive

The diagram below illustrates the continuous drive signals for two channels (switches) and the relationship of the drive parameters to the power supply requirements.

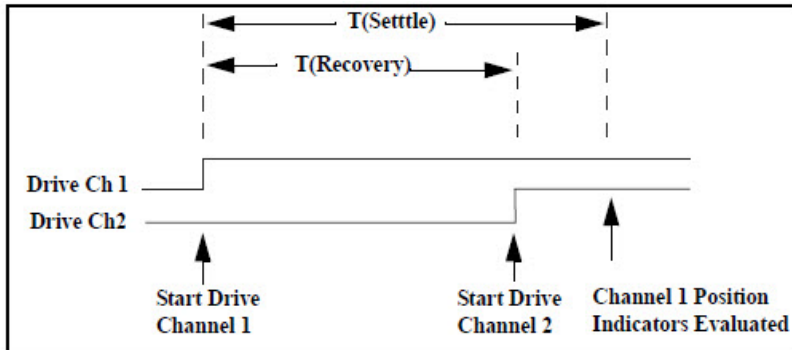

As shown in the diagram, the drive signal is initially applied to channel 1. Drive is applied to channel 2 only after a power supply recovery period has elapsed $T(\text{Recovery})$. The power supply recovery time is set using the `ROUTE:CHANnel:DRIVE:TIME:RECOVERY` command. This parameter may be set individually for each channel or will default to 0.0 ms following either a `SYSTEM:RModule:RESet` or `ROUTE:RModule:BANK:PRESet` command.

If you are verifying the channel closure (see [page 190](#)), you may also specify a $T(\text{Settle})$ parameter. This parameter ensures the switch has had time to change state before the position indicator is evaluated. This parameter may be set individually for each channel or will default to 0.0 ms following either a `SYSTEM:RModule:PRESet` or `ROUTE:RModule:BANK:PRESet` command.

Using Dual Drive Switches and Attenuators

Many microwave switches and attenuators have a paired drive input. Typically, one drive is electrically connected to the lower channel number in a bank and one connected to a corresponding upper channel number. For example, a dual drive switch should have its 'State A' coil connected to channel 21 and its 'State B' coil connected to channel 31 on bank two.

The L4445A drives dual drive devices in pulsed mode only. Pairing two channels automatically configures the channels to pulsed mode (you must explicitly un-pair

the channels before continuous drive mode can be re-enabled). Settings and parameters for pulsed drive mode are given on [page 188](#).

Pairing Channels

With dual drive devices the channels in each bank may be paired (refer to the channel numbering description on [page 183](#)). For example, one drive might be 'State A' and one drive 'State B' on a switch. Pairing channels allows settings and control to be shared between the two drives. To pair channels use the `ROUTE:CHANnel:DRIVE:PAIRed:MODE` command. When paired, the lower and upper channel number on a bank are combined. For example, the following command pairs channel 1 and channel 11 on bank 1.

```
ROUTE:CHANnel:DRIVE:PAIRed:MODE ON, (@1101)
```

You may also pair all channels in a bank by specifying a range of channels:

```
ROUTE:CHANnel:DRIVE:PAIRed:MODE ON, (@1101:1108)
```

Typically, pairing is performed using the lower channel numbers in the bank. You may set channel parameters using either the lower or upper channel number. The settings will apply to both channels in the pair.

You must have the channel drive turned off before attempting to pair channels. Channel drive is turned off by sending the `ROUTE:RMODule:DRIVE:SOURce OFF` command.

Once a channel is paired, only pulse drive is allowed on that channel.

Setting any of the following parameters applies the setting to both of the paired channels:

```
ROUTE:CHANnel:DRIVE:PULSe:WIDTh
```

```
ROUTE:CHANnel:DRIVE:TIMe:RECOvery
```

```
ROUTE:CHANnel:DRIVE:TIMe:SETTle
```

```
ROUTE:CHANnel:VERify:ENABle
```

Using Pulse Drive

To use the pulse drive mode, send the `ROUTE:CHANnel:DRIVE:PULSe:MODE ON` command or pair two channels with the `ROUTE:CHANnel:DRIVE:PAIRed:MODE` command. The diagram below illustrates the pulse drive for two channels (switches) and the relationship of the drive parameters to the power supply requirements.

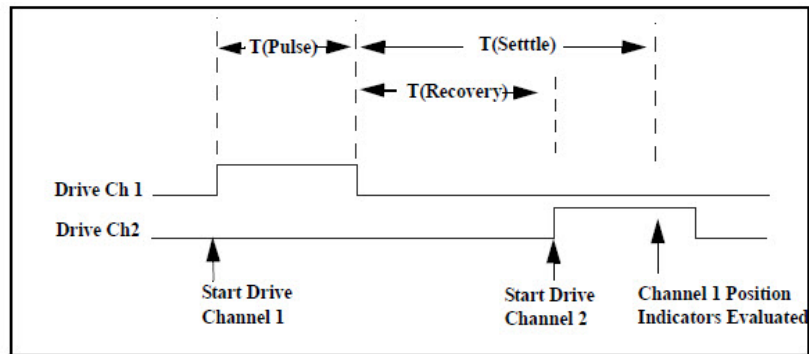

As shown in the diagram, the drive is applied to channel 1 and held for the $T(\text{Pulse})$ time set using the `ROUTE:CHANnel1:DRIVE:PULSE:WIDTh` command. Drive is applied to channel 2 only after a power supply recovery period has elapsed $T(\text{Recovery})$. The power supply recovery time is set using the `ROUTE:CHANnel1:DRIVE:TIME:RECOVery` command. This parameter may be set individually for each channel or will default to 0.0 ms following either a `SYSTEM:RMOdule:RESet` or `ROUTE:RMOdule:BANK:PRESet` command.

If you are verifying the channel operation ([page 190](#)), you may also specify a $T(\text{Settle})$ parameter. During $T(\text{Settle})$ the switch is considered 'busy'. This parameter ensures the switch has had time to change state before the verification. This parameter may be set individually for each channel or will default to 0.0 ms following either a `SYSTEM:RMOdule:RESet` or `ROUTE:RMOdule:BANK:PRESet` command.

Unlike other switch modules, the L4445A will always pulse a channel in response to a `ROUTE:OPEN` or `ROUTE:CLOSE` command. For example, sending `ROUTE:CLOSE` to a channel three times in a row will result in three output pulses.

NOTE

A single drive channel operating in pulse mode with channel verification (see [page 190](#)) turned off (default) will report the channel as 'stateless' and the `ROUTE:CLOSE?` query will return an error. Single drive pulsed channels must have verification enabled (`ROUTE:CHANnel:VERify ON`) to query the channel state using the `ROUTE:CLOSE?` query.

Long Execution Times

When configuring long channel pulse drive times and/or power supply recovery times, be aware that the results may be long execution times. For example, you can set a channel pulse width of 255 ms and a recovery time of 255 ms. This channel will require 510 ms to open or close. If you set such parameters across all the channels on a remote module then the execution time will be over 30 seconds.

Be aware, all channel states are driven when the remote module is reset. So, this lengthy execution can occur following a power on, `*RST`, `SYSTem:CPON`, `SYSTem:PRESet`, or `ROUTe:RMODule:DRIVE:SOURce` command.

Verifying Switch State

Many switches and attenuators have a built-in switch position indicator. This indicator can be used to drive LED position indicators (some position indicator circuits are shown beginning on [page 222](#)). Additionally, the L4445A checks the position indicators against the SCPI command last sent to provide verification of switch states.

By default, verification is disabled and the switch state is assumed to be the last open/close state driven. Verification is enabled using the `ROUTe:CHANnel:VERify:ENABle` command. Enabling verification can cause multiple errors to be generated if the system is incorrectly configured.

If a switch operation appears to have failed, an error is generated at the time the `ROUTe:CLOSe` or `ROUTe:OPEN` command is executed. If you send a `ROUTe:CLOSe` or `ROUTe:OPEN` command with a channel list (i.e., multiple channels), the verification is performed after all open/close operations have been completed. An error is generated for each channel operation that did not properly verify.

The verification process will affect the operation of the `ROUTe:CLOSe?` and `ROUTe:OPEN?` commands. If verification is enabled, these commands will check the actual hardware state of the specified channels, rather than just reporting the presumed state.

When verification is enabled and a remote module is reset, a series of errors will be consolidated and reported as one error.

Verification will slow switching performance on any remote module with one or more verified channels. Additionally, if you have enabled the command overlap function (using the `ROUTe:OPERation:OVERlap:ENABle` command), the verification

will be performed at the end of each close/open operation, before processing the next command.

The state of all verified channels on a remote module is refreshed whenever any channel on that remote module is operated. This helps to ensure the front panel and web based interface have a valid state.

Switch state is stored in the instrument. In contrast, the `ROUTE:OPEN?` and `ROUTE:CLOSE` queries always check the actual hardware state of the switch for verified channels.

For paired operations on the L4445A (using the `ROUTE:CHANnel:DRive:PAIRed:MODE` command), when you enable verification on either paired channel verification will be enabled on both channels. In addition, the module checks for complementary position indicators on the lower and upper channels of the pair (i.e., the position indicators should indicate opposite states). If the state of the lower and upper position indicators are found to be in the same state (due to a hardware issue), an error is generated and the state of the lower channel is assumed.

When the paired mode is disabled and pulsed mode is enabled, you cannot query the open/closed state of the associated channels unless verification is enabled. While in this mode (single drive operation), only “close” operations are allowed on the channels (“open” operations are not allowed). In this mode, a close operation provides a single pulse on the specified channel.

If you enable verification on a non-paired (single drive), non-pulsed (continuous drive) channel on the L4445A, the `ROUTE:CLOSE?` and `ROUTE:OPEN?` commands return the state of the verified device, rather than the drive state of the specified channel. It is possible to have such a channel being driven via a `ROUTE:CLOSE` command by the channel position indicators show the channel as open. In these cases, use the `ROUTE:CHANnel:VERify:POSition:STATe?` command to determine exactly which channels are currently being driven.

The `ROUTE:CHANnel:VERify:POLarity` command sets the logic polarity of the verification lines on specific channels. You can specify the polarity as `NORMAL` (active high) or `INVERTed` (active low).

If you have not enabled verification, you can still query the indicator state of a specific channel using the `ROUTE:CHANnel:VERify:POSition:STATe?` command. This command is useful for channels on which verification is disabled for activities such as debugging or when verification is disabled for performance reasons.

LED Drive

The distribution boards contain a ribbon cable header you can use to connect LEDs to provide a visual indication of switch state. These lines reflect the state of their corresponding channel's position indicator. Some systems use LEDs as a graphical indicator of switch positions.

Use the `ROUTE:RMOdule:BAnt:LED:DRIVE:LEVe1` command to set the drive current for the LEDs. You do not need to provide an external current limiting resistor. This command uses special channel addressing as described in “Remote Module Identifiers” on page 185.

Once the drive current is set, enable the LED drives using the `ROUTE:RMOdule:BAnt:LED:DRIVE:ENABle` command. This command uses special channel addressing as described in “Remote Module Identifiers” on page 185.

NOTE

The LEDs obtain their power from the remote module power supply. If the `ROUTE:RMOdule:DRIVE:SOURce OFF` command has been sent, the LEDs will not operate.

Simplified connections for the position indicators are shown in the diagrams beginning on [page 222](#).

Default and Reset States

The L4445A allows several types of reset and default actions. Most resets rely on states stored in non-volatile memory on the remote modules. Default parameters can be set to ensure the system always returns to a safe state.

SYSTEM:RMOdule:RESet

This command is the only command that will reset all remote modules connected to the L4445A to the factory defaults. No determination of the distribution boards present is made. The system is set to the following conditions after executing this command.

<code>ROUTE:RMOdule:DRIVE:SOURce:IMMediate</code>	OFF
<code>ROUTE:RMOdule:DRIVE:SOURce:BOOT</code>	OFF
<code>ROUTE:RMOdule:DRIVE:LIMit</code>	1

ROUTe:RMOdule:BA NK:DRIVe:MODe	OCOLlector
ROUTe:RMOdule:BA NK:LED:DRIVe:ENABle	ON
ROUTe:RMOdule:BA NK:LED:DRIVe:LEVel	5 mA
ROUTe:CHANnel:DRIVe:PAIRed:MODe	OFF
ROUTe:CHANnel:DRIVe:PULSe:MODe	ON
ROUTe:CHANnel:DRIVe:PULSe:WIDTh	15 ms
ROUTe:CHANnel:DRIVe:TIME:RECOvery	0.0 seconds
ROUTe:CHANnel:DRIVe:TIME:SETTle	0.0 seconds
ROUTe:CHANnel:DRIVe:OPEN:DEFault	OPEN selected
ROUTe:CHANnel:VERify:ENABle	OFF
ROUTe:CHANnel:VERify:POLarity	NORMal

SYSTem:PRESet, *RST, SYSTem:CPON and Power On

These actions drive the channels to their defined **DEFault** state (using the configuration stored on the remote module) and force the system to recognize new topologies (caused by power or connectivity changes). These actions set the defaults shown in the table on [page 192](#). Two parameters are controllable to ensure safety of operation in the system; the default state for channel closure and the default state for drive enabled.

The default channel state (open or closed) for each channel can be set using either of the following commands.

```
ROUTe:CHANnel:DRIVe:CLOSe:DEFault
```

```
ROUTe:CHANnel:DRIVe:OPEN:DEFault
```

NOTE

If a channel is configured for a single drive in pulsed mode, **OPEN** operations are undefined. When these channels are configured to a default state of **OPEN**, no action is taken on these channels.

The drive state can be set as a default using the `ROUTe:RMOdule:DRIVe:SOURce:BOOT` command. This command allows you to specify whether the drive current, when present, should be applied to the switches or not. You can set **OFF**, **INTerna1**, and **EXTerna1** for the default.

The ***RST** command forces a re-evaluation of all connected remote modules, followed by setting all channels to their default states. This is very similar in operation to what occurs at power-up.

ROUTe:RMODule:BaNK:PRESet

This command sets a bank to default values that vary according to which distribution board is attached. The following table shows the default states set by **ROUTe:RMODule:BaNK:PRESet**.

	Y1150A	Y1151A	Y1152A	Y1153A	Y1154A	Y1155A
ROUT:CHAN:DRIV:PULS:MODE	ON	ON	ON	ON	ON	ON
ROUT:CHAN:DRIV:PULS:WIDT	15 ms	15 ms	15 ms	15 ms	15 ms	15 ms
ROUT:CHAN:PAIR:MODE	ON	OFF	ON	ON	ON	OFF
ROUT:CHAN:DRIV:TIME:REC	0 s	0 s	0 s	0 s	0 s	0 s
ROUT:CHAN:DRIV:TIME:SETT	0 s	0 s	0 s	0 s	0 s	0 s
ROUT:CHAN:VER:ENAB	OFF	OFF	OFF	OFF	OFF	OFF
ROUT:CHAN:VER:POL	NORM	NORM	INV	INV	NORM	NORM
ROUT:RMOD:BaNK:DRIV:MODE	OCOL	OCOL	OCOL	OCOL	OCOL	OCOL
ROUT:RMOD:BaNK:LED:DRIV	ON	ON	ON	ON	ON	ON
ROUT:RMOD:BaNK:LED:LEV	0.005 A	0.005 A	0.005 A	0.005 A	0.005 A	0.005 A
ROUT:CHAN:DRIV:CLOS:DEF	OFF	OFF (except channel 7, 17)	ON	OFF	OFF	OFF
ROUT:CHAN:DRIV:OPEN:DEF	ON	ON (except channel 7, 17)	OFF	ON	ON	ON

This command uses special channel addressing as described in “[Remote Module Identifiers](#)” on page 185.

This command requires the channel drive source be in order to allow execution (**ROUTe:RMODule:DRIVE:SOURce OFF**).

Distribution Boards

Each 34945EXT remote module can hold up to four distribution boards. Distribution boards are designed to support the most common types of Keysight microwave switches and attenuators. The table below shows the distribution boards available and lists the supported switches and attenuators.

Y1150A	Distribution board for up to eight N181x SPDT switches (9-pin Dsub connectors)
Y1151A	Distribution board for two 87104x/106x multiport or 87406B matrix switches
Y1152A	Distribution board for a single 87204x/206x or 87606B switches and two N181x SPDT switches
Y1153A	Distribution board for two 84904/5/8x or 8494/5/6 step attenuators
Y1154A	Distribution board for two 87222 transfer switches and up to six N181x SPDT switches
Y1155A	Distribution board with screw terminals for up to 16 switch drives

Specific information for each distribution board and the supported switch types is given in the following sections.

Distribution boards are specialized terminal boards and hold no active electronic components. The distribution boards can be identified by the system (refer to the `SYSTEM:CTYPE:RModule?` and `SYSTEM:CDEscription:RModule?` commands description in the Programmers Reference Help file).

Channel drive attributes for each distribution board will be set to the values shown on [page 194](#).

Y1150A

The Y1150A supports the Keysight N181x series microwave switches shown below. Up to eight switches in any combination can be connected to each distribution board.

Keysight Switch	Description
N1810UL	Unterminated latching 3-port (SPDT)
N1810TL	Terminated latching 3-port (SPDT)

Keysight Switch	Description
N1811TL	Terminated latching 4-port (transfer)
N1812UL	Unterminated latching 5-port

Y1150A Switch Options Supported

(Recommended options are shaded).

Option Name	Option Number	Description and Comments
Frequency Range	various	All options supported
Coil Voltage	105	+5VDC Highest coil current requirement of all coil voltage options. May limit system speed because current capacity limitations. This option draws 600 mA (except N1810UL 300 mA). Therefore, a maximum of 3 (6) devices may be switched simultaneously.
	115	+15VDC
	124	+24VDC (required if using internal power)
DC Connector Type	201	D-Sub 9 pin female
	202	Solder lugs Can use ribbon cables with the Y1150A, or discrete wires with the Y1155A.
RF Performance	various	All options supported
Drive Options	401	TTL/CMOS compatible All switches on the same distribution board must use the same drive mode
	402	Position indicators (required to use verification feature)
	403	Current interrupts For pulsed operation, current interrupts are not required. May provide system switching speed improvements.

Y1150A Connections

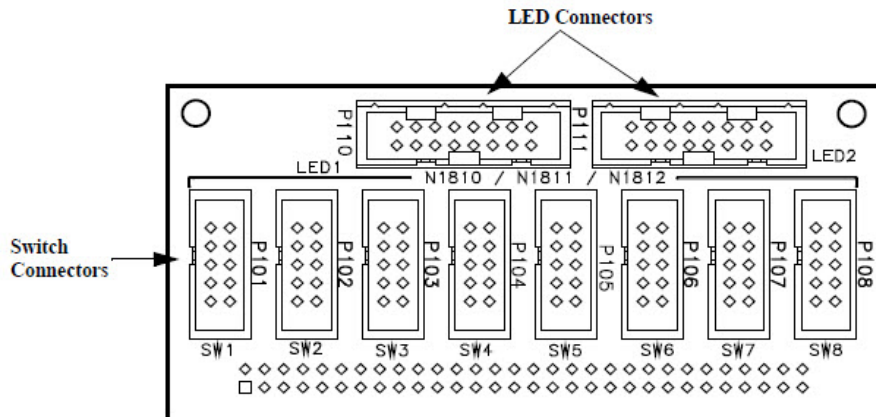

Y1150A Switch Connectors SW1 Through SW8

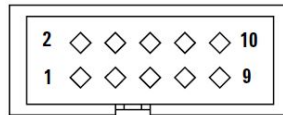

Pin	Use	Pin	Use
1	GND	2	IND B
3	N.C.	4	+VI
5	Drive B	6	IND A
7	Drive A	8	+VI
9	+VR	10	N.C.

+VR is the Voltage source for the Relay

+VI is the Voltage source for the LED Indicator

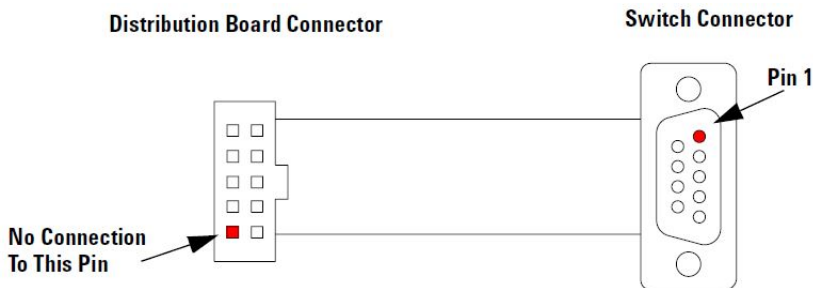

Item	Description	Example Part Numbers
Cable Type	9 conductor ribbon cable, 0.050"pitch, 26 or 28 AWG stranded*	3M 3801/09 (26 AWG) 3M 3365/09 (28 AWG)
Y1150A Connector	10 pin socket connector, 0.1" x 0.1" pin grid, IDC termination, center polarizing key	3M P/N 89110-0101 AMP P/N 76288-1
Switch Connector	9 pin D-sub male, IDC termination, without threaded insert	3M P/N 8209-6000 AMP P/N 747306-4
Cable Wiring	Y1150A socket connector pin 1 to switch D-sub connector pin 1 (Note: pin 10 of Y1150A connector not used)	

* 26 AWG recommended for 5V coil switches

Y1150A Switch Control

All switches are driven in PAIRed mode.

	State A	State B
SW1	ROUT:OPEN (@xx01)	ROUT:CLOS (@xx01)
SW2	ROUT:OPEN (@xx02)	ROUT:CLOS (@xx02)
SW3	ROUT:OPEN (@xx03)	ROUT:CLOS (@xx03)
SW4	ROUT:OPEN (@xx04)	ROUT:CLOS (@xx04)
SW5	ROUT:OPEN (@xx05)	ROUT:CLOS (@xx05)
SW6	ROUT:OPEN (@xx06)	ROUT:CLOS (@xx06)

	State A	State B
SW7	ROUT:OPEN (@xx07)	ROUT:CLOS (@xx07)
SW8	ROUT:OPEN (@xx08)	ROUT:CLOS (@xx08)

Y1150A LED Connectors LED1 and LED2

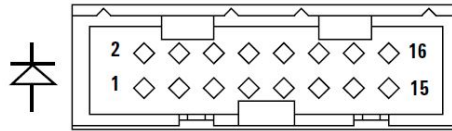

LED1 Connector				LED2 Connector			
Pin	Use	Pin	Use	Pin	Use	Pin	Use
1	+VI	2	SW1 - A	1	+VI	2	SW5 - A
3	+VI	4	SW1 - B	3	+VI	4	SW5 - B
5	+VI	6	SW2 - A	5	+VI	6	SW6 - A
7	+VI	8	SW2 - B	7	+VI	8	SW6 - B
9	+VI	10	SW3 - A	9	+VI	10	SW7 - A
11	+VI	12	SW3 - B	11	+VI	12	SW7 - B
13	+VI	14	SW4 - A	13	+VI	14	SW8 - A
15	+VI	16	SW4 - B	15	+VI	16	SW8 - B

Y1151A

The Y1151A supports up to two of the Keysight microwave switches shown below.

Keysight Switch	Description
87104A/B/C	SP4T 4 port latching
87106A/B/C	SP6T 6 port latching
87406B	6 port matrix

Y1151A Switch Options Supported

(Recommended options are shaded).

Option Name	Option Number	Description and Comments
Frequency Range	letter suffix in model number	All options supported
Coil Voltage	STD (no options)	+24VDC nominal (+20VDC to +32VDC allowed)
DC Connector Type	STD	16 pin ribbon cable header
	100	Solder lugs Can use ribbon cables with the Y1150A, or discrete wires with the Y1155A.
Calibration Certificate	UK6, UKS	All options supported
Drive Options	STD	Direct coil connections for open drain drive
	T24	TTL/CMOS compatible All switches on the same distribution board must use the same drive mode.
	T00 (87406 only)	Solder lugs and TTL/5V CMOS compatible options combined - see comments above.

Y1151A Connections

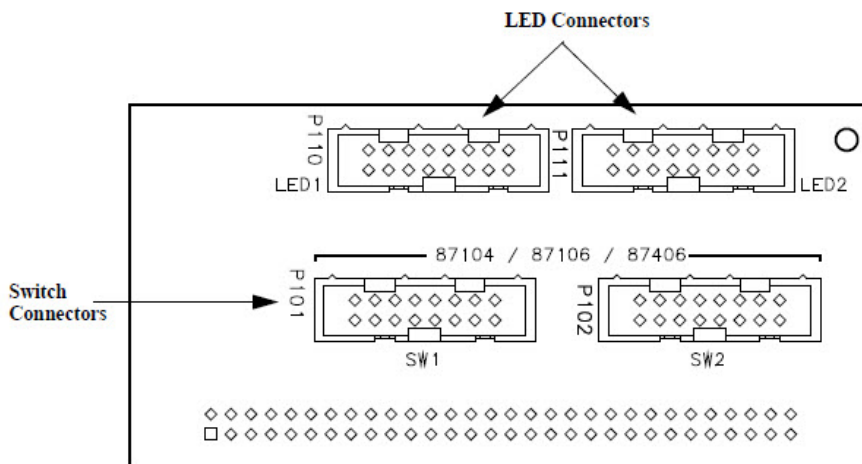

Y1151A Switch Connector SW1 and SW2

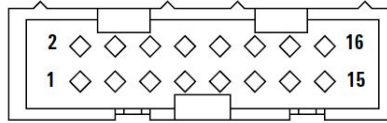

Pin	Use	Pin	Use
1	+VR	2	+VI
3	Path 1	4	IND 1
5	Path 2	6	IND 2
7	Path 3	8	IND 3
9	Path 4	10	IND 4
11	Path 5	12	IND 5
13	Path 6	14	IND 6
15	GND	16	Open All Paths

+VR is the Voltage source for the Relay

+VI is the Voltage source the LED Indicator

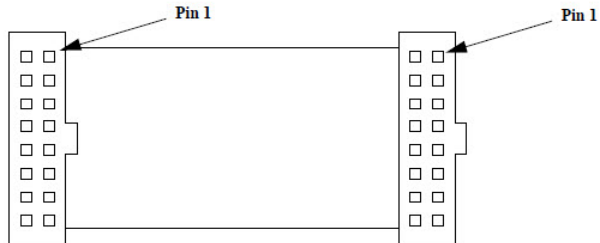

Item	Description	Example Part Numbers
Cable Type	16 conductor ribbon cable, 0.050" pitch, 26 or 28 AWG stranded	3M 3801/16 (26 AWG) 3M 3365/16 (28 AWG)
Y1151A Connector	16 pin socket connector, 0.1" x 0.1" pin grid, IDC termination, center polarizing key	3M P/N 89116-0101 AMP P/N 76288-3
Switch Connector	16 pin socket connector, 0.1" x 0.1" pin grid, IDC termination, center polarizing key	3M P/N 89116-0101 AMP P/N 76288-3
Cable Wiring	Y1151A socket connector pin 1 to switch connector pin 1	

Y1151A Switch Control

All channels are single drive.

	Path Closed	Path Open
SW1 Path 1	ROUT:CLOS (@xx01)	Close another path or open all
SW1 Path 2	ROUT:CLOS (@xx02)	Close another path or open all
SW1 Path 3	ROUT:CLOS (@xx03)	Close another path or open all
SW1 Path 4	ROUT:CLOS (@xx04)	Close another path or open all
SW1 Path 5	ROUT:CLOS (@xx05)	Close another path or open all
SW1 Path 6	ROUT:CLOS (@xx06)	Close another path or open all
SW1 Open All 1	ROUT:CLOS (@xx07)	
SW2 Open All 1	ROUT:CLOS (@xx08)	
SW2 Path 1	ROUT:CLOS (@xx011)	Close another path or open all
SW2 Path 2	ROUT:CLOS (@xx012)	Close another path or open all
SW2 Path 3	ROUT:CLOS (@xx013)	Close another path or open all
SW2 Path 4	ROUT:CLOS (@xx014)	Close another path or open all
SW2 Path 5	ROUT:CLOS (@xx015)	Close another path or open all
SW2 Path 6	ROUT:CLOS (@xx016)	Close another path or open all

	Path Closed	Path Open
SW2 Open All 2	ROUT:CLOS (@xx017)	
SW2 Open All 2	ROUT:CLOS (@xx018)	

Y1151A LED Connectors LED1 and LED2

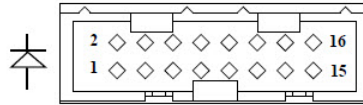

LED1 Connector				LED2 Connector			
Pin	Use	Pin	Use	Pin	Use	Pin	Use
1	+VI	2	SW1 - Path 1	1	+VI	2	SW2 - Path 1
3	+VI	4	SW1 - Path 2	3	+VI	4	SW2 - Path 2
5	+VI	6	SW1 - Path 3	5	+VI	6	SW2 - Path 3
7	+VI	8	SW1 - Path 4	7	+VI	8	SW2 - Path 4
9	+VI	10	SW1 - Path 5	9	+VI	10	SW2 - Path 5
11	+VI	12	SW1 - Path 6	11	+VI	12	SW2 - Path 6
13	+VI	14	Not Used	13	+VI	14	Not Used
15	+VI	16	Not Used	15	+VI	16	Not Used

Y1152A

The Y1152A supports one of the 87xxx switches and up to two of the Keysight N181x switches. Supported switches are shown below.

Keysight Switch	Description
87204A/B/C	SP4T 4 port latching
87206A/B/C	SP6T 6 port latching

Keysight Switch	Description
87606B	6 port matrix
N1810UL	Unterminated latching 3-port (SPDT)
N1810TL	Terminated latching 3-port (SPDT)
N1811TL	Terminated latching 4-port (transfer)
N1812UL	Unterminated latching 5-port

Y1152A Switch Options Supported

(Recommended options are shaded).

Option Name	Option Number	Description and Comments
Frequency Range	letter suffix in model number	All options supported
Coil Voltage	STD (no options)	+24VDC nominal (+20VDC to +32VDC allowed)
DC Connector Type	STD	16 pin ribbon cable header
	100	Solder lugs Can use ribbon cables with the Y1152A, or discrete wires with the Y1155A.
Calibration Certificate	UK6, UKS	All options supported
Drive Options	STD	Direct coil connections for open drain drive

Y1152A Connections

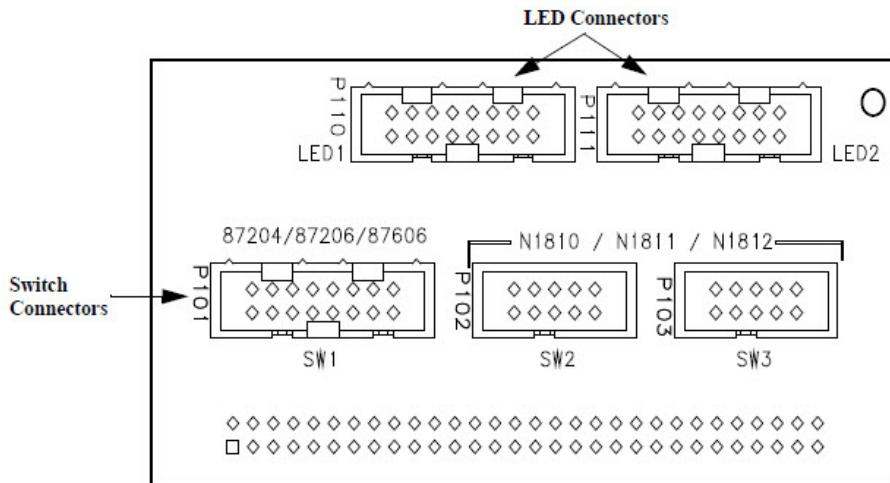

Y1152A Switch connector SW1 (87204/06)

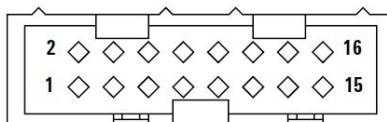

Pin	Use	Pin	Use
1	+VR	2	N.C.
3	Close 1	4	Open 1
5	Close 2	6	Open 2
7	Close 3	8	Open 3
9	Close 4	10	Open 4
11	Close 5	12	Open 5
13	Close 6	14	Open 6
15	GND	16	N.C.

Y1152A Switch Connector SW2 and SW3 (N181x)

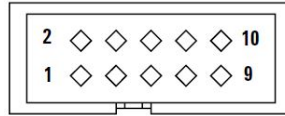

Pin	Use	Pin	Use
1	GND	2	IND B
3	N.C.	4	+VI
5	Drive B	6	IND A
7	Drive A	8	+VI
9	+VR	10	N.C.

+VR is the Voltage source for the Relay
 +VI is the Voltage source for the LED Indicator

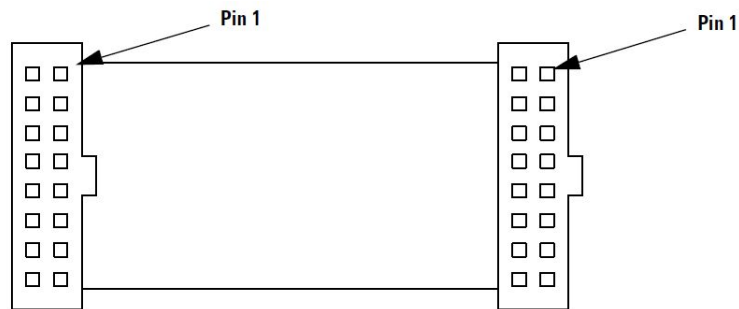

Distribution Board Connector

Switch Connector



16 Conductor Cable

Item	Description	Example Part Numbers
Cable Type	16 conductor ribbon cable, 0.050" pitch, 26 or 28 AWG stranded	3M 3801/16 (26 AWG) 3M 3365/16 (28 AWG)
Y1152A Connector	10 pin socket connector, 0.1" x 0.1" pin grid, IDC termination, center polarizing key	3M P/N 89116-0101 AMP P/N 76288-3
Switch Connector	16 pin socket connector, 0.1" x 0.1" pin grid, IDC termination, center polarizing key	3M P/N 89116-0101 AMP P/N 76288-3
Cable Wiring	Y1152A connector pin 1 to switch connector pin 1	

9 Conductor Cable

Item	Description	Example Part Numbers
Cable Type	9 conductor ribbon cable, 0.050" pitch, 26 or 28 AWG stranded	3M 3801/16 (26 AWG) 3M 3365/16 (28 AWG)
Y1150A Connector	10 pin socket connector, 0.1" x 0.1" pin grid, IDC termination, center polarizing key	3M P/N 89116-0101 AMP P/N 76288-3
Switch Connector	16 pin socket connector, 0.1" x 0.1" pin grid, IDC termination, center polarizing key	3M P/N 89116-0101 AMP P/N 76288-3
Cable Wiring	Y1152A connector pin 1 to switch connector pin 1 (Note: pin 10 of Y1152A connector not used)	

Y1152A Switch Control

All channels are driven in PAIRed mode.

	Path closed*	Path open*
SW1 Path1	ROUT:OPEN (@xx01)	ROUT:CLOS (@xx01)
SW1 Path2	ROUT:OPEN (@xx02)	ROUT:CLOS (@xx02)
SW1 Path3	ROUT:OPEN (@xx03)	ROUT:CLOS (@xx03)
SW1 Path4	ROUT:OPEN (@xx04)	ROUT:CLOS (@xx04)
SW1 Path5	ROUT:OPEN (@xx05)	ROUT:CLOS (@xx05)
SW1 Path6	ROUT:OPEN (@xx06)	ROUT:CLOS (@xx06)

	State A	State B
SW2	ROUT:OPEN (@xx07)	ROUT:CLOS (@xx07)
SW3	ROUT:OPEN (@xx08)	ROUT:CLOS (@xx08)

* For switches connected to SW1, note the path closed is accomplished with the ROUTe:OPEN command.

Y1152A LED Connectors LED1 and LED2

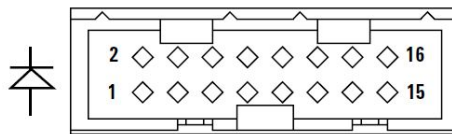

LED1 Connector				LED2 Connector			
Pin	Use	Pin	Use	Pin	Use	Pin	Use
1	+VI	2	SW1 - Close 1	1	+VI	2	SW1 - Close 5
3	+VI	4	SW1 - Open 1	3	+VI	4	SW1 - Open 5
5	+VI	6	SW1 - Close 2	5	+VI	6	SW1 - Close 6
7	+VI	8	SW1 - Open 2	7	+VI	8	SW1 - Open 6
9	+VI	10	SW1 - Close 3	9	+VI	10	SW2 - Ind A
11	+VI	12	SW1 - Open 3	11	+VI	12	SW2 - Ind B
13	+VI	14	SW1 - Close 4	13	+VI	14	SW3 - Ind A
15	+VI	16	SW1 - Open 4	15	+VI	16	SW3 - Ind B

Y1153A

The Y1153A supports the attenuators listed below. Up to two of the attenuators may be connected.

Keysight Switch	Description
84904K/L	11 dB max, 1 dB steps, 4 sections
84906K/L	90 dB max, 10 dB steps, 4 sections

Keysight Switch	Description
84907K/L	70 dB max, 10 dB steps, 3 sections
84904M	11 dB max, 1 dB steps, 4 sections
84905M	60 dB max, 10 dB steps, 3 sections
84908M	65 dB max, 5 dB steps, 4 sections
8494G/H	11 dB max, 1 dB steps, 4 sections
8495G/H	70 dB max, 10 dB steps, 3 sections
8496G/H	110 dB max, 10 dB steps, 4 sections

Y1153A Attenuator Options Supported

(Recommended options are shaded)

84904/5/6/7/8

Option Name	Option Number	Description and Comments
Frequency Range	letter suffix in model number	All options supported
RF Connectors	various	All options supported
Coil Voltage	011	+5VDC
	015	+15VDC
	024	+24VDC (required if using internal power)
DC Connector Type	STD	10 pin ribbon cable header
Calibration Certificate	UK6	All options supported

8494/5/6

Option Name	Option Number	Description and Comments
Frequency Range	letter suffix in model number	All options supported
RF Connectors	various	All options supported
Coil Voltage	STD	+24VDC

Option Name	Option Number	Description and Comments
DC Connector Type	STD	12 pin Viking connector (includes 5 foot cable with Viking connector on one end, no terminations on other end)
	016	Flat Pack - ribbon cable connected to attenuator with 14 pin DIP header on free end. Not recommended.
Calibration Certificate	UK6	All options supported

Y1153A Connections

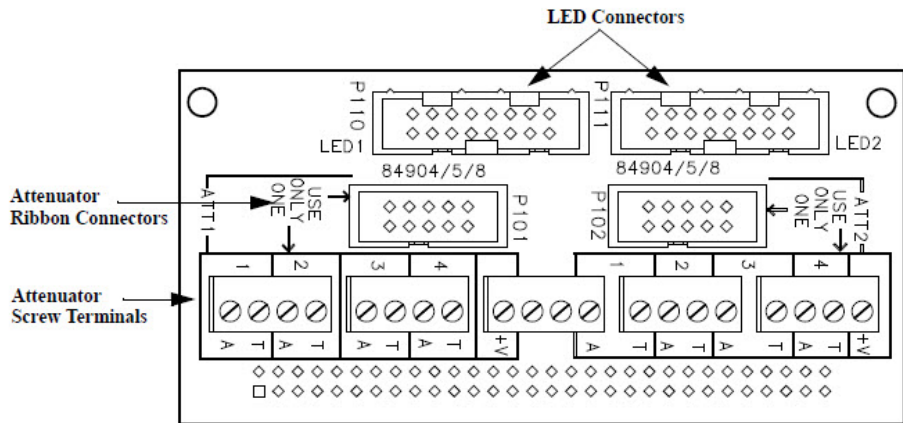

Y1153A Attenuator connector P101 and P102 (84904/5/8)

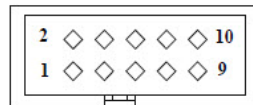

Pin	Use	Pin	Use
1	Section 1 Thru Line	2	Section 1 Atten
3	N.C.	4	Section 3 Thru Line
5	Section 2 Thru Line	6	Section 4 Thru Line

Pin	Use	Pin	Use
7	Section 4 Atten	8	Section 2 Atten
9	Section 3 Atten	10	+VR

NOTE

You may use either the ribbon cable header or the screw terminals to make connections to the attenuators. You should not use both.

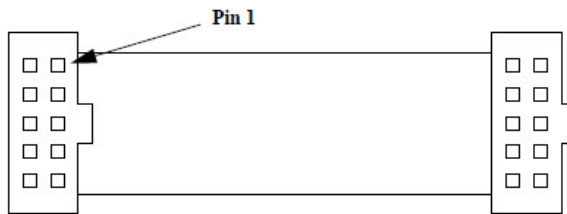
**84904/5/6/7/8**

Item	Description	Example Part Numbers
Cable Type	10 conductor ribbon cable, 0.050" pitch, 26 or 28 AWG stranded	3M 3801/10 (26 AWG) 3M 3365/10 (28 AWG)
Y1153A Connector	10 pin socket connector, 0.1" x 0.1" pin grid, IDC termination, center polarizing key	3M P/N 89110-0101 AMP P/N 76288-1
Attenuator Connector	10 pin socket connector, 0.1" x 0.1" pin grid, IDC termination, center polarizing key	3M P/N 89110-0101 AMP P/N 76288-1
Cable Wiring	Y1153A connector pin 1 to switch connector pin 1	

8494/5/6

Item	Description	Example Part Numbers
Cable Supplied with Attenuator	Cable with Viking connector on attenuator end, bare wires on other end	Keysight 8120-2178
Cable Type	12 conductor round cable, 22 or 24 AWG stranded, 0.25" dia.	
Y1153A Connector	Screw terminals provided on Y1153A distribution cable connection	
Attenuator Connector	12 pin Viking Industries, Inc. circular connector	Viking connector body TNP12-102P contacts TS-100-AU
Cable Wiring	See attenuator manual	

Y1153A Attenuator Control

All channel are operated in **PAIRed** mode.

	Attenuation Section In	Attenuation Section Out
ATTEN 1 SECTION 1	ROUT:OPEN (@xx01)	ROUT:CLOS (@xx01)
ATTEN 1 SECTION 2	ROUT:OPEN (@xx02)	ROUT:CLOS (@xx02)
ATTEN 1 SECTION 3	ROUT:OPEN (@xx03)	ROUT:CLOS (@xx03)
ATTEN 1 SECTION 4	ROUT:OPEN (@xx04)	ROUT:CLOS (@xx04)
ATTEN 2 SECTION 1	ROUT:OPEN (@xx05)	ROUT:CLOS (@xx05)
ATTEN 2 SECTION 2	ROUT:OPEN (@xx06)	ROUT:CLOS (@xx06)
ATTEN 2 SECTION 3	ROUT:OPEN (@xx07)	ROUT:CLOS (@xx07)
ATTEN 2 SECTION 4	ROUT:OPEN (@xx08)	ROUT:CLOS (@xx08)

NOTE

ROUTE:OPEN adds that section's attenuation amount to the overall attenuation. Total attenuation is the sum of the dB amounts for the individual sections switched in.

When all channels open at reset maximum attenuation is set.

Y1153A LED Connectors LED1 and LED2

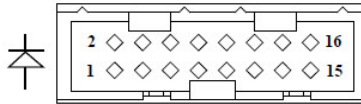

LED1 Connector				LED2 Connector			
Pin	Use	Pin	Use	Pin	Use	Pin	Use
1	+VI	2	P101 Atten 1	1	+VI	2	P102 Atten 1
3	+VI	4	P101 Thru Line 1	3	+VI	4	P102 Thru Line 1
5	+VI	6	P101 Atten 2	5	+VI	6	P102 Atten 2
7	+VI	8	P101 Thru Line 2	7	+VI	8	P102 Thru Line 2
9	+VI	10	P101 Atten 3	9	+VI	10	P102 Atten 3
11	+VI	12	P101 Thru Line 3	11	+VI	12	P102 Thru Line 3
13	+VI	14	P101 Atten 4	13	+VI	14	P102 Atten 4
15	+VI	16	P101 Thru Line 4	15	+VI	16	P102 Thru Line 4

Y1154A

The Y1154A supports one of the transfer switches listed below and up to six N181x switches.

Keysight Switch	Description
87222C/D/E	4 port transfer switch
N1810UL	Unterminated latching 3-port (SPDT)
N1810TL	Terminated latching 3-port (SPDT)
N1811TL	Terminated latching 4-port (transfer)
N1812UL	Unterminated latching 5-port

Y1154A Switch Options Supported

(Recommended options are shaded).

Option Name	Option Number	Description and Comments
Frequency Range	letter suffix in model number	All options supported
Coil Voltage	STD (no options)	+24VDC nominal (+20VDC to +32VDC allowed)
DC Connector Type	STD	10 pin ribbon cable header
	100	Solder lugs Can use ribbon cables with the Y1154A, or discrete wires with the Y1155A.
Mounting Bracket	201	All options supported
Calibration Certificate	UK6	All options supported
Drive Options	STD	Direct coil connections for open collector drive and TTL/5V CMOS compatible inputs standard

Y1154A Connections

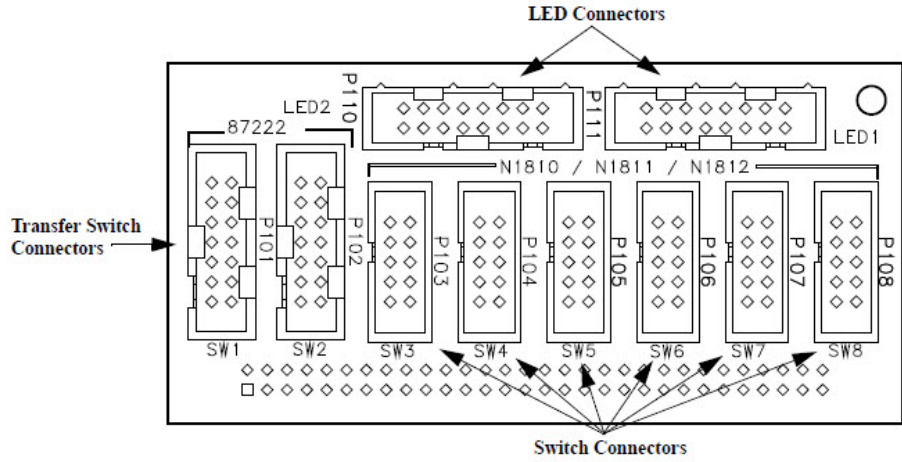

Y1154A Switch connector SW1 and SW2 (87222)

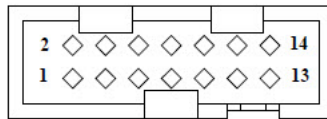

Pin	Use	Pin	Use
1	+VR	2	+VI
3	Drive A	4	Ind A
5	Drive B	6	Ind B
7	N.C.	8	N.C.
9	GND	10	N.C.
11	N.C.	12	N.C.
13	N.C.	14	N.C.

Y1154A Switch connector SW3 Through SW8 (N181x)

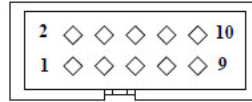

Pin	Use	Pin	Use
1	GND	2	IND B
3	N.C.	4	+VI
5	Drive B	6	IND A
7	Drive A	8	+VI
9	+VR	10	N.C.

+VR is the Voltage source for the Relay
 +VI is the Voltage source for the LED Indicator

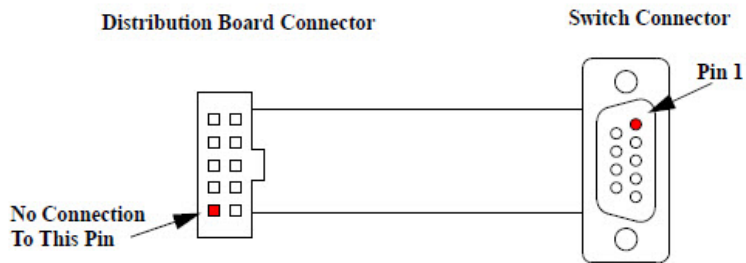
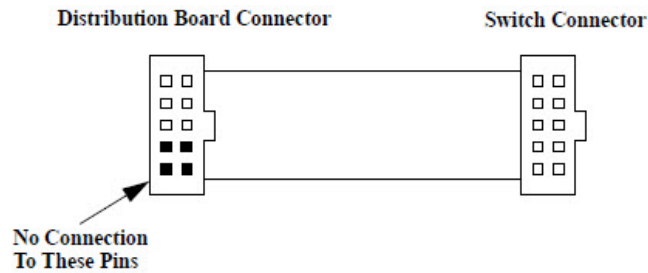

87222 Cable

Item	Description	Example Part Numbers
Cable Type	10 conductor ribbon cable, 0.050" pitch, 26 or 28 AWG stranded	3M 3801/10 (26 AWG) 3M 3365/10 (28 AWG)
Y1154A Connector	14 pin socket connector, 0.1" x 0.1" pin grid, IDC termination, center polarizing key	3M P/N 89114-0101 AMP P/N 76288-2
Switch Connector	10 pin socket connector, 0.1" x 0.1" pin grid, IDC termination, center polarizing key	3M P/N 89110-0101 AMP P/N 76288-1
Cable Wiring	Y1154A connector pin 1 to switch connector pin 1 (Note: pins 11 - 14 of 14 pin connector not used)	

9 Conductor Cable

Item	Description	Example Part Numbers
Cable Type	9 conductor ribbon cable, 0.050" pitch, 26 or 28 AWG stranded	3M 3801/09 (26 AWG) 3M 3365/09 (28 AWG)
Y1154A Connector	10 pin socket connector, 0.1" x 0.1" pin grid, IDC termination, center polarizing key	3M P/N 89110-0101 AMP P/N 76288-1
Switch Connector	9 pin D-sub male, IDC termination, without threaded insert	3M P/N 8209-6000 AMP P/N 747306-4
Cable Wiring	Y1154A socket connector pin 1 to switch D-sub connector pin 1 (Note: pin 10 of Y1154A connector not used)	

Y1154A Switch Control

All channels are operated in PAIRed mode.

	State A	State B
SW1	ROUT:OPEN (@xx01)	ROUT:CLOS (@xx01)
SW2	ROUT:OPEN (@xx02)	ROUT:CLOS (@xx02)
SW3	ROUT:OPEN (@xx03)	ROUT:CLOS (@xx03)
SW4	ROUT:OPEN (@xx04)	ROUT:CLOS (@xx04)

	State A	State B
SW5	ROUT:OPEN (@xx05)	ROUT:CLOS (@xx05)
SW6	ROUT:OPEN (@xx06)	ROUT:CLOS (@xx06)
SW7	ROUT:OPEN (@xx07)	ROUT:OPEN (@xx07)
SW8	ROUT:OPEN (@xx08)	ROUT:OPEN (@xx08)

Y1154A LED Connectors LED1 and LED2

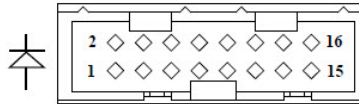

LED1 Connector				LED2 Connector			
Pin	Use	Pin	Use	Pin	Use	Pin	Use
1	+VI	2	SW1 - A	1	+VI	2	SW5 - A
3	+VI	4	SW1 - B	3	+VI	4	SW5 - B
5	+VI	6	SW2 - A	5	+VI	6	SW6 - A
7	+VI	8	SW2 - B	7	+VI	8	SW6 - B
9	+VI	10	SW3 - A	9	+VI	10	SW7 - A
11	+VI	12	SW3 - B	11	+VI	12	SW7 - B
13	+VI	14	SW4 - A	13	+VI	14	SW8 - A
15	+VI	16	SW4 - B	15	+VI	16	SW8 - B

Y1155A

The Y1155A provides screw terminal connections can support the Keysight switches listed below. Additionally, the screw terminals make it adaptable to most any switch.

Keysight Switch	Description
8762A/B/C	Terminated latching 3-port (SPDT)
8762F	75 ohm terminated SPDT
8763A/B/C	Terminated latching 4-port (transfer)
8764A/B/C	Terminated latching 5-port
Other Switches	Numerous

NOTE

When using the Y1155A, the ROUTe:RMOdule:BAntk:PRESet command's default configuration (see [page 194](#)) may not be suitable for the wide variety of switches and devices available. You will need to manually configure the channel drive attributes to ensure safe reset operations of these switch systems.

Y1155A Switch Options Supported

Recommended options are shaded.

Option Name	Option Number	Description and Comments
Frequency Range	Various	All options supported
Coil Voltage	011	+5VDC +5VDC
		Highest coil current requirement of all coil voltage options. May limit system speed because current capacity limitations. 34945EXT limits total switch current to 2A; opt 011 coils draw 400 mA. Therefore, a maximum of 5 devices may be switched simultaneously.
		015
	024	+24VDC (required if using internal power)
DC Connector Type	STD	solder lugs
RF Performance	various	All options supported
Drive Options	STD	Direct coil connections for open collector drive

Option Name	Option Number	Description and Comments
	T24	TTL/5V CMOS compatible inputs with +24VDC coils (Note: position indicators do not function; wiring pattern differs from direct drive)
	T15	TTL/5V CMOS compatible inputs with +15VDC coils (Note: position indicators do not function; wiring pattern differs from direct drive)

Y1155A Connections

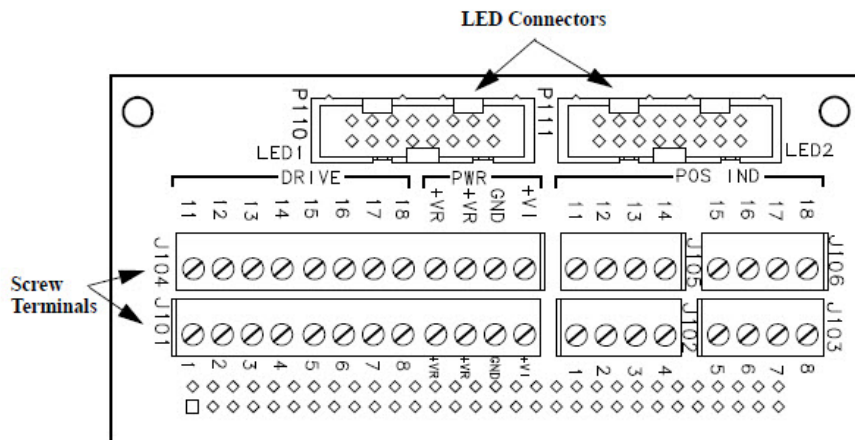

+VR is the Voltage source for the Relay
 +VI is the Voltage source for the LED Indicator

876x Switches

Item	Description
Cable Type	3 wire cable, 24 AWG stranded
Y1155A Connector	Screw terminal connection for wire provided on Y1155A
Switch Connector	Solder wire to switch solder lug
Cable Wiring	Varies with drive option; see switch documentation

Y1155A Switch Control

Paired Operations*

Drive 1	ROUT:OPEN (@xx01)	Drive 11	ROUT:CLOS (@xx01)
Drive 2	ROUT:OPEN (@xx02)	Drive 12	ROUT:CLOS (@xx02)
Drive 3	ROUT:OPEN (@xx03)	Drive 13	ROUT:CLOS (@xx03)
Drive 4	ROUT:OPEN (@xx04)	Drive 14	ROUT:CLOS (@xx04)
Drive 5	ROUT:OPEN (@xx05)	Drive 15	ROUT:CLOS (@xx05)
Drive 6	ROUT:OPEN (@xx06)	Drive 16	ROUT:CLOS (@xx06)
Drive 7	ROUT:OPEN (@xx07)	Drive 17	ROUT:OPEN (@xx07)
Drive 8	ROUT:OPEN (@xx08)	Drive 18	ROUT:OPEN (@xx08)

*PAIRed operation must be configured manually. The ROUTe:RMOdule:BA NK:PRESet does not configure Y1155A channels for PAIRed operations.

Unpaired Operations

Drive 1	ROUT:CLOS (@xx01)
Drive 2	ROUT:CLOS (@xx02)
Drive 3	ROUT:CLOS (@xx03)
Drive 4	ROUT:CLOS (@xx04)
Drive 5	ROUT:CLOS (@xx05)
Drive 6	ROUT:CLOS (@xx06)
Drive 7	ROUT:CLOS (@xx07)
Drive 8	ROUT:CLOS (@xx08)
Drive 9	ROUT:CLOS (@xx09)
Drive 10	ROUT:CLOS (@xx10)
Drive 11	ROUT:CLOS (@xx11)
Drive 12	ROUT:CLOS (@xx12)
Drive 13	ROUT:CLOS (@xx13)
Drive 14	ROUT:CLOS (@xx14)
Drive 15	ROUT:CLOS (@xx15)
Drive 16	ROUT:CLOS (@xx16)

Drive 17	ROUT:CLOS (@xx17)
Drive 18	ROUT:CLOS (@xx18)

Y1155A LED Connectors LED1 and LED2

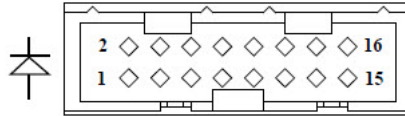

LED1 Connector				LED2 Connector			
Pin	Use	Pin	Use	Pin	Use	Pin	Use
1	+VI	2	SW1 - A	1	+VI	2	SW5 - A
3	+VI	4	SW1 - B	3	+VI	4	SW5 - B
5	+VI	6	SW2 - A	5	+VI	6	SW6 - A
7	+VI	8	SW2 - B	7	+VI	8	SW6 - B
9	+VI	10	SW3 - A	9	+VI	10	SW7 - A
11	+VI	12	SW3 - B	11	+VI	12	SW7 - B
13	+VI	14	SW4 - A	13	+VI	14	SW8 - A
15	+VI	16	SW4 - B	15	+VI	16	SW8 - B

Simplified Connection Diagrams

Single Drive With Separate Position Indicators

The simplified schematic below illustrates the connection for a single drive switch with separate position indicators. The position indicators for this type of switch are independent relay contacts that are mechanically linked to the RF switch position.

Even though this is a single drive switch, each switch state has its own coil. The switch uses internal logic to open all paths except the one being closed.

The RF paths are not shown in the simplified diagram. The coils are driven in open collector mode. The position indicator is set so that a high level indicates an

active switch. The logic level of the position indicator can be inverted using the `ROUTE:CHANnel:VERify:POLarity` command.

The schematic shown is similar to the Keysight 87104A/B/C, 87106A/B/C, and 87406B switches. Many other switches use this technique (both with and without the position indicator).

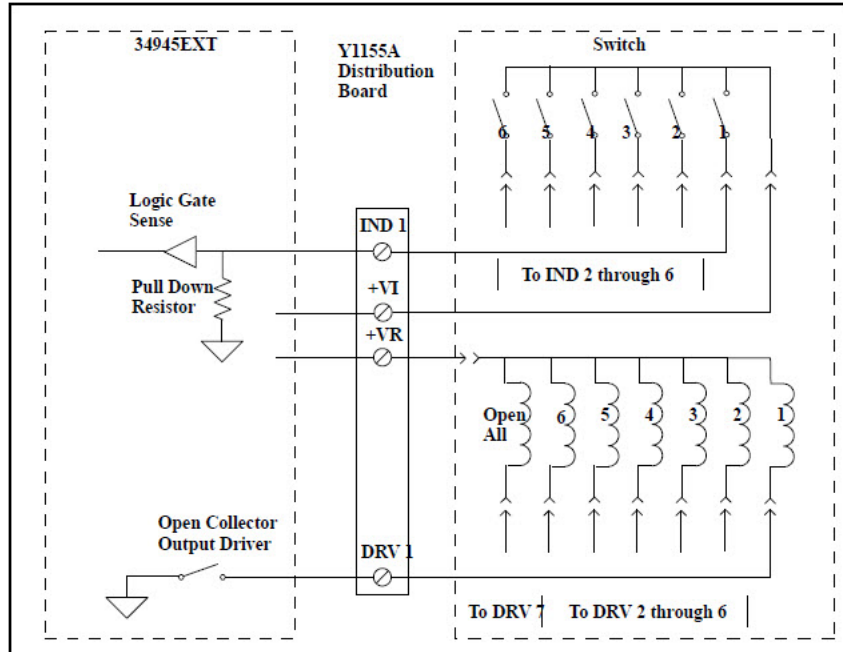

Paired Drive With Separate Position Indicators

The simplified schematic below illustrates the connection for a dual drive switch with separate position indicators. The position indicators for this type of switch are independent relay contacts that are mechanically linked to the RF switch position.

The RF paths are not shown in the simplified diagram. The coils are driven in open collector mode. The position indicator is set so that a high level indicates an active switch. The logic level of the position indicator can be inverted using the `ROUTE:CHANnel:VERify:POLarity` command.

As shown, Channel 01 was pulsed to close Coil A. The corresponding position indicator also closed. Closing position indicator A opens position indicator B.

The schematic shown is similar to the Keysight N181x series of switches.

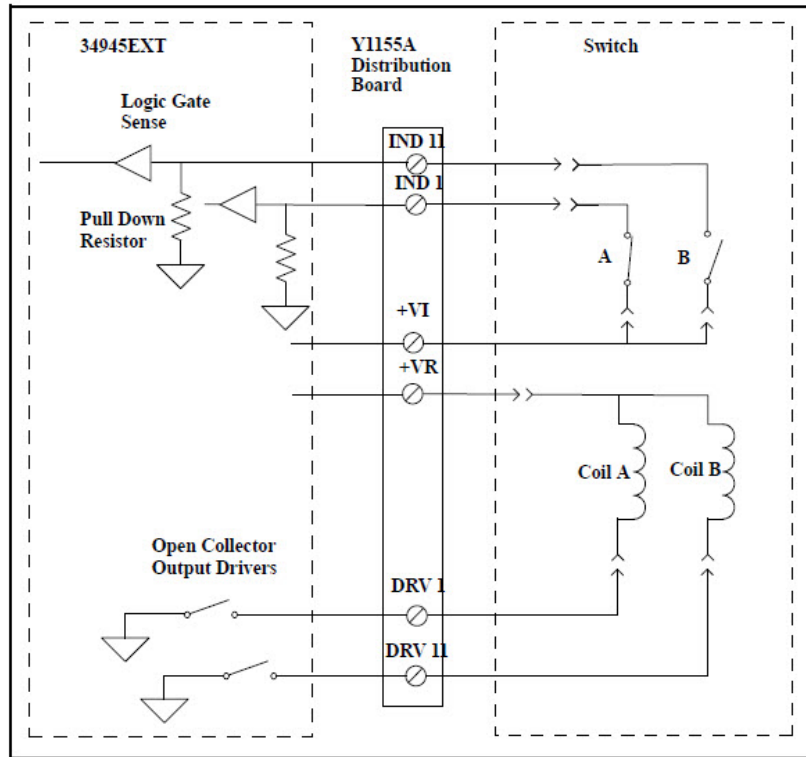

Paired Drive With Combined Position Indicators

The simplified schematic below illustrates the connection for a dual drive switch with an integral position indicator. The position indicators for this type of switch are electrically connected to the device's drive coil. This is a typical arrangement for microwave attenuators. For these types of position indicators, you must make a parallel connection at the distribution board between the channel drive and the indicator input.

With these types of devices, positive voltage is present on the paired coil opposite the position the switch is currently in. Typically you will need to invert the logic level of the position indicator using the `ROUTE:CHANnel:VERify:POLarity` command.

As shown, Channel 01 was pulsed to close Port 1. The corresponding position indicator also closed.

The schematic shown is similar to the Keysight 876x series of switches and 849x series of step attenuators.

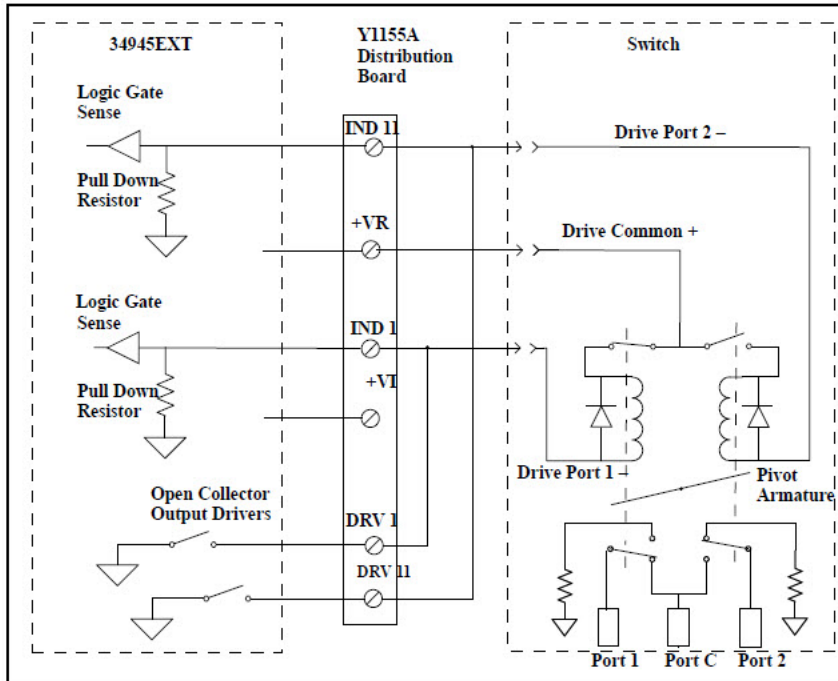

Mounting the Remote Modules

The figure below shows the dimensions of the remote module and the locations of usable mounting holes.

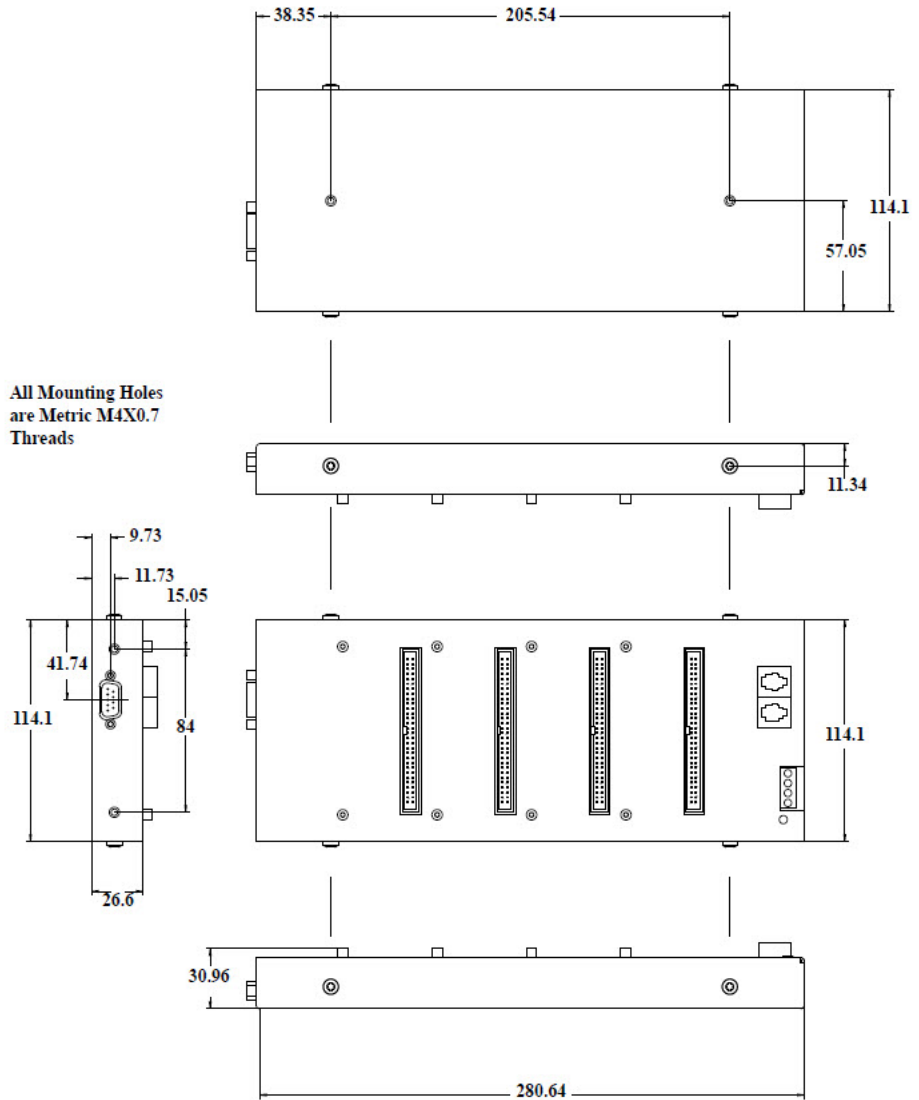

SCPI Programming Examples

These programming examples provide you with SCPI command examples to use for driving the microwave switch modules.

The channel addressing scheme used in these examples follow the form 1rcc where r is the remote module number (1 through 8), and cc is the two-digit channel number. For more information about channel numbering, refer to [“Channel Numbering”](#) on page 183.

For complete information on SCPI commands, see the *Programmer’s Reference Help* file.

Example: Configuring an Keysight N1810UL

The following example illustrate controlling an Keysight N1810UL attached to a Y1150A distribution board. The distribution board is connected to Bank 1 of the first remote module attached to the L4445A. This example uses the bank preset (described on [page 194](#)).

```
ROUTE:RMODule:DRIVE:SOURce OFF, (@1100)
ROUTE:RMODule:BANK:PRESet BANK1, (@1100)
ROUTE:RMODule:DRIVE:SOURce INT, (@1101)
ROUT:CLoSe (@1101)
```

Example: Configuring a Paired Drive Channel

The following example illustrates the sequence of commands used to configure a paired drive channel. In the example, the operations are directed to channel 1 on remote module 3.

The drive source must be disabled before configuring either the channel pairing or the pulse mode. The channel is then paired and the pulse width set to 15 ms. Power supply recovery time and settling time is then set to 12 ms and 10 ms, respectively. Verify is then enabled. The default behavior for the switches is set to OPEN and TTL drive using an EXTERNAL power supply. Finally, the channel is closed.

```
ROUTE:RMODule:DRIVE:SOURce OFF, (@1300)
ROUTE:CHANnel:DRIVE:PAIRed ON, (@1301)
ROUTE:CHANnel:DRIVE:PULSe 0.015, (@1301)
ROUTE:CHANnel:DRIVE:TIME:SETTle 0.012, (@1301)
```

```

ROUTe:CHANnel:DRIVe:TIME:RECOvERY 0.010, (@1301)
ROUTe:CHANnel:VERify ON, (@1301)
ROUTe:CHANnel:DRIVe:OPEN:DEFault (@1301)
ROUTe:RMODule:BA NK:DRIVe:MODE TTL, BANK1, (@1300)
ROUTe:RMODule:DRIVe:SOURce EXT, (@1300)

ROUT:CLOSe (@1301)

```

Example: Configuring a Single Drive Channel

The following example illustrates the sequence of commands to configure a single drive channel with continuous drive. In the example, the operations are directed to channel 1 on remote module 3.

The drive source must be disabled before configuring pulse or paired modes. The channel is then un-paired and the pulse mode disabled (enables continuous drive). Power supply recovery time and settling time is then set to 10 ms and 12 ms, respectively. Verify is then enabled. The switches are set to a **CLOSE** default state and **OCOLlector** drive with an **EXTeRnal** power supply is selected. The channel is closed. The final query of the channel state involves querying both verified state and whether channel drive is occurring.

```

ROUTe:RMODule:DRIVe:SOURce OFF, (@1300)
ROUTe:CHANnel:DRIVe:PAIRed OFF, (@1301)
ROUTe:CHANnel:DRIVe:PULSe:MODE OFF, (@1301)
ROUTe:CHANnel:DRIVe:TIME:SETTle 0.010, (@1301)
ROUTe:CHANnel:DRIVe:TIME:RECOvERY 0.012, (@1301)
ROUTe:CHANnel:VERify ON, (@1301)
ROUTe:CHANnel:DRIVe:CLOSe:DEFault (@1301)
ROUTe:RMOD:BA NK:DRIVe:MODE OCOLlector, BANK1, (@1300)
ROUTe:RMODule:DRIVe:SOURce EXT, (@1300)

ROUT:CLOSe (@1301)
ROUT:CLOSe? (@1301)
ROUTe:CHANnel:DRIVe:STATe? (@1301)

```

The `ROUTe:CHANnel:DRIVe:STATe?` query returns a 0 if the channel is not being driven and a 1 if the channel is being driven.

8 L4450A 64-Bit Digital I/O with Memory and Counter

L4450A SCPI Command Summary	232
L4450A 64-Bit Digital I/O with Memory and Counter	243
Basic Digital I/O Operations	244
Handshaking	247
Buffered I/O Operations	255
Interrupt Lines	259
Byte Ordering	260
Pattern Matching	261
Counter	262
Initiated Measurement Mode	263
Clock	264
L4450A D-Sub Connectors	265
34950T Terminal Block	268

L4450A SCPI Command Summary

Table 8-1 lists the instrument-specific SCPI commands that apply to the L4450A 64-Bit Digital I/O and Counter instrument. **Table 3-3** (Chapter 3) lists the SCPI commands that apply to all L4400 series instruments.

For complete information on all SCPI commands, refer to the Programmer's Reference at www.keysight.com/find/L4400.

Table 8-1 L4450A SCPI Command Summary.

Subsystem	Commands
CONFigure (Counter / Totalizer)	CONFigure:COUNTer:DCYCLE [{<gate_time> MIN MAX DEF},] (@<ch_list>)
	CONFigure:COUNTer:FREQuency [{<gate_time> MIN MAX DEF},] (@<ch_list>)
	CONFigure:COUNTer:PERiod [{<gate_time> MIN MAX DEF},] (@<ch_list>)
	CONFigure:COUNTer:PWIDth [{<gate_time> MIN MAX DEF},] (@<ch_list>)
	CONFigure:COUNTer:TOTalize [{READ RRESet},] (@<ch_list>)
	CONFigure:TOTalize [{READ RRESet},] (@<ch_list>)

Subsystem	Commands
CONFigure (Digital I/O)	CONFigure:DIgital {BYTE 1 WORD 2 LWORD 4}, [<voltage>], [{NORMal INVerted}], (@<ch_list>)
	CONFigure:DIgital:DIRectioN {INPut 0 OUTPut 1}, (@<ch_list>)
	CONFigure:DIgital:DIRectioN? (@<ch_list>)
	CONFigure:DIgital:HANDshake SYNChronous, [<thresh_voltage>, [<level_voltage>, [<polarity>]]] (@<ch_list>)
	CONFigure:DIgital:HANDshake:CTIME {<seconds> MIN MAX DEF}, (@<ch_list>)
	CONFigure:DIgital:HANDshake:CTIME? [{MIN MAX}], (@<ch_list>)
	CONFigure:DIgital:HANDshake:DRIVE {ACTive OCOLlector}, (@<ch_list>)
	CONFigure:DIgital:HANDshake:DRIVE? (@<ch_list>)
	CONFigure:DIgital:HANDshake:POLarity {NORMal INVerted}, [{H0 H1 1 H2 2 ALL}], (@<ch_list>)
	CONFigure:DIgital:HANDshake:POLarity? {H0 H1 1 H2 2}, (@<ch_list>)
	CONFigure:DIgital:HANDshake:RATE {<frequency> MIN MAX DEF}, (@<ch_list>)
	CONFigure:DIgital:HANDshake:RATE? [{MIN MAX}], (@<ch_list>)
	CONFigure:DIgital:HANDshake:STATe {HIMPedance OFF ON}, (@<ch_list>)
	CONFigure:DIgital:HANDshake:STATe? (@<ch_list>)
	CONFigure:DIgital:HANDshake:SYNChronous:STRobe[:SOURce] {INTernal EXTernal}, (@<ch_list>)
	CONFigure:DIgital:HANDshake:SYNChronous:STRobe[:SOURce]? (@<ch_list>)
	CONFigure:DIgital:INTerrupt:POLarity {NORMal INVerted}, (@<ch_list>)
	CONFigure:DIgital:INTerrupt:POLarity? (@<ch_list>)
	CONFigure:DIgital:POLarity {NORMal INVerted}, (@<ch_list>)
	CONFigure:DIgital:POLarity? (@<ch_list>)
CONFigure:DIgital:WIDTh {BYTE 1 WORD 2 LWORD 4}, (@<ch_list>)	
CONFigure:DIgital:WIDTh? (@<ch_list>)	

Subsystem	Commands
MEASure (Counter / Totalizer)	MEASure:COUNter:DCYClE? [{<gate_time> MIN MAX DEF},] (@<ch_list>) MEASure:COUNter:FREQuency? [{<gate_time> MIN MAX DEF},] (@<ch_list>) MEASure:COUNter:PERiod? [{<gate_time> MIN MAX DEF},] (@<ch_list>) MEASure:COUNter:PWIDth? [{<gate_time> MIN MAX DEF},] (@<ch_list>) MEASure:COUNter:TOTalize? [{READ RRESet},] (@<ch_list>)
MEASure (Digital I/O)	MEASure:DIGital? {BYTE 1 WORD 2 LWORD 4}, [<voltage>, [{NORMal INVerted} ,] (@<ch_list>)

Subsystem	Commands
SENSe (Counter / Totalizer)	[SENSe:]COUNter:ABORt (@<ch_list>)
	[SENSe:]COUNter:DATA? (@<ch_list>)
	[SENSe:]COUNter:DCYClE[:DATA]? (@<ch_list>)
	[SENSe:]COUNter:FREQuency[:DATA]? (@<ch_list>)
	[SENSe:]COUNter:FUNcTION {FREQuency PERiod DCYClE PWIth TOTAlize}, (@<ch_list>)
	[SENSe:]COUNter:FUNcTION? (@<ch_list>)
	[SENSe:]COUNter:GATE:POLarity {NORMAl INVerted}, (@<ch_list>)
	[SENSe:]COUNter:GATE:POLarity? (@<ch_list>)
	[SENSe:]COUNter:GATE:SOURce {INternAl EXternAl}, (@<ch_list>)
	[SENSe:]COUNter:GATE:SOURce? (@<ch_list>)
	[SENSe:]COUNter:GATE:TIME[:INternAl] {<time> MIN MAX DEF}, (@<ch_list>)
	[SENSe:]COUNter:GATE:TIME[:INternAl]? [{MIN MAX},] (@<ch_list>)
	[SENSe:]COUNter:INITiate (@<ch_list>)
	[SENSe:]COUNter:PERiod[:DATA]? (@<ch_list>)
	[SENSe:]COUNter:PWIth[:DATA]? (@<ch_list>)
	[SENSe:]COUNter:SLOPe {NEGAtive POSitive}, (@<ch_list>)
	[SENSe:]COUNter:SLOPe? (@<ch_list>)
	[SENSe:]COUNter:THReshold:VOLTage {<voltage> MIN MAX DEF}, (@<ch_list>)
	[SENSe:]COUNter:THReshold:VOLTage? [{MIN MAX},] (@<ch_list>)
	[SENSe:]COUNter:TOTAlize:CLear:IMMediate (@<ch_list>)
	[SENSe:]COUNter:TOTAlize[:DATA]? (@<ch_list>)
	[SENSe:]COUNter:TOTAlize:TYPE {READ RRESet}, (@<ch_list>)
	[SENSe:]COUNter:TOTAlize:TYPE? (@<ch_list>)
	[SENSe:]MODule:COUNter:GATE:THReshold[:VOLTage] {<voltage> MIN MAX DEF}, 1
	[SENSe:]MODule:COUNter:GATE:THReshold[:VOLTage]? [{MIN MAX},] 1
	[SENSe:]TOTAlize:CLear:IMMediate (@<ch_list>)
	[SENSe:]TOTAlize:DATA? (@<ch_list>)
	[SENSe:]TOTAlize:SLOPe {NEGAtive POSitive}, (@<ch_list>)
	[SENSe:]TOTAlize:SLOPe? (@<ch_list>)
	[SENSe:]TOTAlize:THReshold[:MODE] {AC TTL}, (@<ch_list>)
	[SENSe:]TOTAlize:THReshold[:MODE]? (@<ch_list>)
	[SENSe:]TOTAlize:THReshold:VOLTage {<voltage> MIN MAX DEF}, (@<ch_list>)
	[SENSe:]TOTAlize:THReshold:VOLTage? [{MIN MAX},] (@<ch_list>)
	[SENSe:]TOTAlize:TYPE {READ RRESet}, (@<ch_list>)
[SENSe:]TOTAlize:TYPE? (@<ch_list>)	

Subsystem	Commands
SENSe (Digital I/O)	[SENSe:]DIGital:DATA[:{BYTE 1 WORD 2 LWORD 4}]? [{DECimal BINary HEXadecimal OCTal},] (@<ch_list>)
	[SENSe:]DIGital:DATA:BIT? <bit>, (@<ch_list>)
	[SENSe:]DIGital:HANDshake:THReshold {<voltage> MIN MAX DEF}, (@<ch_list>)
	[SENSe:]DIGital:HANDshake:THReshold? [{MIN MAX},] (@<ch_list>)
	[SENSe:]DIGital:INTerrupt[:ENABLE] {OFF ON 1}, (@<ch_list>)
	[SENSe:]DIGital:INTerrupt[:ENABLE]? (@<ch_list>)
	[SENSe:]DIGital:INTerrupt:MODE {MFUL COMPare}, (@<ch_list>)
	[SENSe:]DIGital:INTerrupt:MODE? (@<ch_list>)
	[SENSe:]DIGital:INTerrupt:STATus? (@<ch_list>)
	[SENSe:]DIGital:MEMory:CLEar (@<ch_list>)
	[SENSe:]DIGital:MEMory:COMPare:ACTion {CONTInue STARt STOP}, (@<ch_list>)
	[SENSe:]DIGital:MEMory:COMPare:ACTion? (@<ch_list>)
	[SENSe:]DIGital:MEMory[:DATA]? <index>, <count>, (@<channel>)
	[SENSe:]DIGital:MEMory[:DATA]:ALL? (@<channel>)
	[SENSe:]DIGital:MEMory[:DATA]:FORMat {LIST BLOCK}
	[SENSe:]DIGital:MEMory[:DATA]:FORMat?
	[SENSe:]DIGital:MEMory[:DATA]:POINts? [MAX,] (@<ch_list>)
	[SENSe:]DIGital:MEMory:ENABle {OFF ON 1}, (@<ch_list>)
	[SENSe:]DIGital:MEMory:ENABle? (@<ch_list>)
	[SENSe:]DIGital:MEMory:MATCH[:DATA]? (@<ch_list>)
SENSe:]DIGital:MEMory:SAMPle:COUNt {<count> MIN MAX DEF INfInity}, (@<ch_list>)	
[SENSe:]DIGital:MEMory:STARt (@<ch_list>)	
[SENSe:]DIGital:MEMory:STEP (@<ch_list>)	
[SENSe:]DIGital:MEMory:STOP (@<ch_list>)	
[SENSe:]DIGital:THReshold {<voltage> MIN MAX DEF}, (@<ch_list>)	
[SENSe:]DIGital:THReshold? [{MIN MAX},] (@<ch_list>)	
SENSe (Digital Pattern Compare)	[SENSe:]DIGital:MEMory:COMPare:ACTion {CONTInue STARt STOP}, (@<ch_list>)
	[SENSe:]DIGital:MEMory:COMPare:ACTion? (@<ch_list>)

Subsystem	Commands
SOURce (Digital I/O)	SOURce:DIGital:DATA[:{BYTE 1 WORD 2 LWORD 4}] <data>, (@<ch_list>)
	SOURce:DIGital:DATA[:{BYTE 1 WORD 2 LWORD 4}]?
	[{DECimal BINary HEXadecimal OCTal},] (@<ch_list>)
	SOURce:DIGital:DATA:BIT {0 1}, <bit>, (@<ch_list>)
	SOURce:DIGital:DATA:BIT? <bit>, (@<ch_list>)
	SOURce:DIGital:DRive {ACTive COLlector}, (@<ch_list>)
	SOURce:DIGital:DRive? (@<ch_list>)
	SOURce:DIGital:HANdshake:LEVel {<voltage> MIN MAX DEF}, (@<ch_list>)
	SOURce:DIGital:HANdshake:LEVel? [{MIN MAX},] (@<ch_list>)
	SOURce:DIGital:INTerrupt[:ENABLE] {OFF 0 ON 1}, (@<ch_list>)
	SOURce:DIGital:INTerrupt[:ENABLE]? (@<ch_list>)
	:SOURce:DIGital:INTerrupt:MODE {START STOP GATE}, (@<ch_list>)
	:SOURce:DIGital:INTerrupt:MODE? (@<ch_list>)
	SOURce:DIGital:LEVel {<voltage> MIN MAX DEF}, (@<ch_list>)
	SOURce:DIGital:LEVel? [{MIN MAX},] (@<ch_list>)
	SOURce:DIGital:MEMory:ABORT (@<ch_list>)
	SOURce:DIGital:MEMory:ENABle {OFF 0 ON 1}, (@<ch_list>)
	SOURce:DIGital:MEMory:ENABle? (@<ch_list>)
	SOURce:DIGital:MEMory:NCYCles {<count> MIN MAX DEF INFinity}, (@<ch_list>)
	SOURce:DIGital:MEMory:NCYCles? [{MIN MAX},] (@<ch_list>)
	SOURce:DIGital:MEMory:STARt (@<ch_list>)
	SOURce:DIGital:MEMory:STEP (@<ch_list>)
	SOURce:DIGital:MEMory:STOP (@<ch_list>)
SOURce:DIGital:MEMory:TRACe <name>, (@<channel>)	
SOURce:DIGital:MEMory:TRACe? (@<channel>)	
SOURce:DIGital:STATe {OFF 0 ON 1}, (@<ch_list>)	
SOURce:DIGital:STATe? (@<ch_list>)	
SOURce (External Clock Output)	SOURce:MODule:CLOCK:FREQuency {<frequency> MIN MAX DEF}, 1
	SOURce:MODule:CLOCK:FREQuency? [{MIN MAX},] 1
	SOURce:MODule:CLOCK:LEVel {<voltage> MIN MAX DEF}, 1
	SOURce:MODule:CLOCK:LEVel? [{MIN MAX},] 1
	SOURce:MODule:CLOCK:STATe {OFF 0 ON 1}, 1
	SOURce:MODule:CLOCK:STATe? 1

Subsystem	Commands
TRACe	TRACe:CATalog? {(@<channel>) 1} TRACe[:DATA]:DIGital[:{BYTE 1 WORD 2 LWORD 4}] (@<channel>), <name>, {<binary_block> <value>, <value> [,<value>, ...]} TRACe[:DATA]:DIGital:FUNction (@<channel>), {COUNT WONES}, <name>, <points> TRACe:DELeTe:ALL {(@<channel>) 1} TRACe:DELeTe:NAME] {(@<channel>) 1}, <name> TRACe:FREE? {(@<channel>) 1} TRACe:POINts? {(@<channel>) 1}, <name>
CALCulate (Digital Pattern Compare)	CALCulate:COMParE:DATA[:{BYTE 1 WORD 2 LWORD 4}] <data>, (@<ch_list>) CALCulate:COMParE:DATA? (@<ch_list>) CALCulate:COMParE:MASK[:{BYTE 1 WORD 2 LWORD 4}] <data>, (@<ch_list>) CALCulate:COMParE:MASK? (@<ch_list>) CALCulate:COMParE:STATe {OFF 0 ON 1}, (@<ch_list>) CALCulate:COMParE:STATe? (@<ch_list>) CALCulate:COMParE:TYPE {EQUal NEQual}, (@<ch_list>) CALCulate:COMParE:TYPE? (@<ch_list>)
CALCulate (Alarm Limit)	CALCulate:LIMit:LOWer {<value> MIN MAX DEF}, (@<ch_list>) CALCulate:LIMit:LOWer? [{MIN MAX},] (@<ch_list>) CALCulate:LIMit:LOWer:STATe {OFF 0 ON 1}, (@<ch_list>) CALCulate:LIMit:LOWer:STATe? (@<ch_list>) CALCulate:LIMit:UPPer {<value> MIN MAX DEF}, (@<ch_list>) CALCulate:LIMit:UPPer? [{MIN MAX},] (@<ch_list>) CALCulate:LIMit:UPPer:STATe {OFF 0 ON 1}, (@<ch_list>) CALCulate:LIMit:UPPer:STATe? (@<ch_list>)

Subsystem	Commands
CALCulate (Measurement Statistics)	CALCulate:AVERage:AVERage? [(@<ch_list>)]
	CALCulate:AVERage:CLear [(@<ch_list>)]
	CALCulate:AVERage:COUNT? [(@<ch_list>)]
	CALCulate:AVERage:MAXimum? [(@<ch_list>)]
	CALCulate:AVERage:MAXimum:TIME? [(@<ch_list>)]
	CALCulate:AVERage:MINimum? [(@<ch_list>)]
	CALCulate:AVERage:MINimum:TIME? [(@<ch_list>)]
	CALCulate:AVERage:PTPeak? [(@<ch_list>)]
CALCulate (MX + B Scaling)	CALCulate:SCALE:GAIN <gain> [, (@<ch_list>)]
	CALCulate:SCALE:GAIN? (@<ch_list>)
	CALCulate:SCALE:OFFSet <offset> [, (@<ch_list>)]
	CALCulate:SCALE:OFFSet? (@<ch_list>)
	CALCulate:SCALE:STATe {OFF 0 ON 1} [, (@<ch_list>)]
	CALCulate:SCALE:STATe? [(@<ch_list>)]
	CALCulate:SCALE:UNIT "<units>" [, (@<ch_list>)]
CALCulate:SCALE:UNIT? [(@<ch_list>)]	
ROUTe (Monitor)	ROUTe:MONitor:DATA?
	ROUTe:MONitor:MODE {CHANnel DMM}
	ROUTe:MONitor:MODE?
	ROUTe:MONitor:STATe {OFF 0 ON 1}
	ROUTe:MONitor:STATe?
	ROUTe:MONitor[:CHANnel] (@<channel>)
	ROUTe:MONitor[:CHANnel]?
	ROUTe:MONitor[:CHANnel]:ENABLE {OFF 0 ON 1}, (@<ch_list>)
ROUTe:MONitor[:CHANnel]:ENABLE? (@<ch_list>)	

Subsystem	Commands
ROUTE (Scanning)	ABORT INITiate ROUTe:CHANnel:DElay {<seconds> MIN MAX DEF}, (@<ch_list>) ROUTe:CHANnel:DElay? [{MIN MAX},] (@<ch_list>) ROUTe:CHANnel:DElay:AUTO {OFF 0 ON 1}, (@<ch_list>) ROUTe:CHANnel:DElay:AUTO? (@<ch_list>) ROUTe:SCAN (@<scan_list>) ROUTe:SCAN? ROUTe:SCAN:ADD (@<ch_list>) ROUTe:SCAN:REMove (@<ch_list>) ROUTe:SCAN:ORDeRed {OFF 0 ON 1} ROUTe:SCAN:ORDeRed? ROUTe:SCAN:SIZE?
ROUTE (Switch Control)	ROUTe:CHANnel:LABel:CLEar:MODule 1 ROUTe:CHANnel:LABel[:DEFine] "<label>" , (@<ch_list>) ROUTe:CHANnel:LABel[:DEFine]? [{USER FACTory},] (@<ch_list>)
ROUTE (Sequence Operation)	ROUTe:SEQuence:CATalog? ROUTe:SEQuence:DEFine <name>, "<commands>" ROUTe:SEQuence:DEFine? <name> ROUTe:SEQuence:DELete:ALL ROUTe:SEQuence:DELete[:NAME] <name> ROUTe:SEQuence:DONE? ROUTe:SEQuence:TRIGger[:IMMediate] <name> ROUTe:SEQuence:TRIGger:SOURce <name>, {ALARm1 ALARm2 MANual} ROUTe:SEQuence:TRIGger:SOURce? <name> ROUTe:SEQuence:WAIT

Subsystem	Commands
OUTPut (Alarm Limit)	OUTPut:ALARm{1 2}:CLEar OUTPut:ALARm:CLEar:ALL OUTPut:ALARm:MODE {LATCH TRACK} OUTPut:ALARm:MODE? OUTPut:ALARm{1 2}:SEQuence? OUTPut:ALARm:SLOPe {NEGAtive POSitive} OUTPut:ALARm:SLOPe? OUTPut:ALARm{1 2}:SOURce (@<ch_list>) OUTPut:ALARm{1 2}:SOURce?
FORMat (Scanning)	FORMat:BORDer {NORMal SWApped} FORMat:BORDer? FORMat:READing:ALARm {OFF 0 ON 1} FORMat:READing:ALARm? FORMat:READing:CHANnel {OFF 0 ON 1} FORMat:READing:CHANnel? FORMat:READing:TIME {OFF 0 ON 1} FORMat:READing:TIME? FORMat:READing:TIME:TYPE {ABSolute RELative} FORMat:READing:TIME:TYPE? FORMat:READing:UNIT {OFF 0 ON 1} FORMat:READing:UNIT? READ?
SWEEp (Scanning)	SWEEp:COUNT {<count> MIN MAX DEF} SWEEp:COUNT? [{MIN MAX}]

Subsystem	Commands
TRIGger	*TRG INITiate READ? [(@<ch_list>)] TRIGger:COUNT {<count> MIN MAX DEF INFinity} TRIGger:COUNT? [{MIN MAX}] TRIGger:DElay {<seconds> MIN MAX} TRIGger:DElay? [{MIN MAX}] TRIGger:DElay:AUTO {OFF ON 1} TRIGger:DElay:AUTO? TRIGger:SOURce {IMMediate BUS EXternal TImeR} TRIGger:SOURce? TRIGger:SOURce:ALARm[:MODE] {SINGle CONTInuous} TRIGger:SOURce:ALARm[:MODE]? TRIGger:TImeR {<seconds> MIN MAX DEF} TRIGger:TImeR? [{MIN MAX}]
TRIGger (Scanning)	TRIGger:COUNT {<count> MIN MAX DEF INFinity} TRIGger:COUNT? [{MIN MAX}] TRIGger:SOURce {IMMediate BUS EXternal ALARm1 ALARm2 TImeR} TRIGger:SOURce? TRIGger:TImeR {<seconds> MIN MAX DEF} TRIGger:TImeR? [{MIN MAX}]
Data (Reading Memory)	DATA:POINts:EVENT:THReshold <num_readings> DATA:POINts:EVENT:THReshold? DATA:POINts? DATA:REMOve? <num_readings> FETCh? R? [<max_count>] SYSTem:TIME:SCAN?
Data (Measurement Statistics)	DATA:LAST? [,(@<channel>)]

L4450A 64-Bit Digital I/O with Memory and Counter

The L4450A has 64-bits of general-purpose digital I/O grouped in 8-bit channels with programmable polarity, input thresholds, and output levels. The module is segmented into two banks of four 8-bit channels. Each bank has 64 Kb of volatile memory for pattern capture and pattern generation with hardware interrupt capability. Up to three pins of handshaking are available for each bank of 32 bits.

The module also has two 10 MHz frequency counter/totalizer measurement input channels and a programmable clock output for frequency synchronization or general clocking needs.

The digital channels are numbered by bank; 101 through 104 and 201 through 204 for banks 1 and 2 respectively. The counter/totalizer channels are assigned channel numbers 301 and 302. The programmable clock is not assigned a channel number.

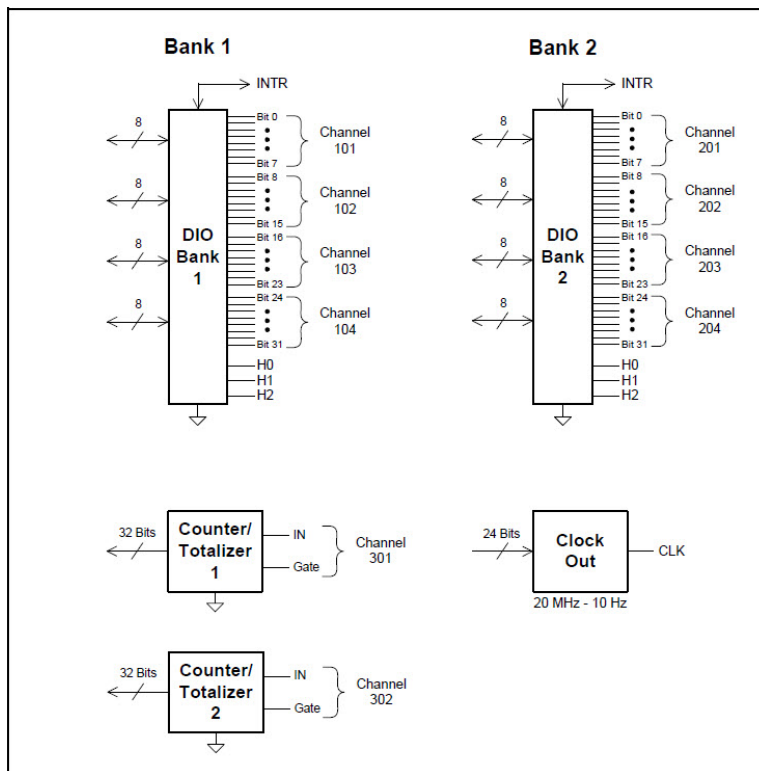

Basic Digital I/O Operations

Channel Numbering and Width

The digital channels are numbered by bank; 101 through 104 and 201 through 204 for banks 1 and 2 respectively.

Using SCPI commands you can group digital I/O channels together to allow 16- or 32-bit operations. The first and third channels on a bank can be control channels. Width and direction of the memory operations are controlled by the width and direction of the first channel on the bank (i.e., 101 or 201). In the SCPI language for the L4450A, BYTE refers to 8-bit operations, WORD refers to 16-bit operations, and LWORd refers to 32-bit operations.

This diagram illustrates how the channels are numbered for each configuration.

	Bank 1				Bank 2			
	Channel							
BYTE (default)	101 8-bits	102 8-bits	103 8-bits	104 8-bits	201 8-bits	202 8-bits	203 8-bits	204 8-bits
WORD	101		103		201		203	
	16-bits		16-bits		16-bits		16-bits	
LWORD	101				201			
	32-bits				32-bits			

Reading Digital Data

The simplest way to read a digital channel is using the `MEASure:DIgital?` query. This query sets the channel to be an input channel and sets all other channel parameters to the default settings.

For example, sending the following SCPI command to the L4450A will read the value of the 8-bit channel 102. An unsigned integer value is returned that represents the state of the 8 bits on channel 102.

```
MEAS:DIg? BYTE, (@1102)
```

By adding parameters to the command, you can set the channel width, threshold, and polarity for read. For example, sending the following SCPI command you can read the 32-bit channel 201.

```
MEAS:DIG? LWOR, 2.5, NORM, (@1201)
```

To read digital data with more control over the channel parameters, use the SCPI **CONFigure** and **SENSe** commands. The **CONFigure** commands set up the digital I/O channel parameters. For example, sending the following SCPI command sets 16-bit input channel 103 to use a 2.5 V input threshold, and normal polarity.

```
CONF:DIG WORD, 2.5, NORM, (@1103)
```

Once configured, the data is read using the following command.

```
SENS:DIG:DATA:WORD? (@1103)
```

You may also read an individual bit using the **SENSe** commands. This allows you to check the state of an individual bit in a channel without having to create an input mask. For example, the following command returns the state of bit 3 in the channel 101 byte.

```
SENS:DIG:DATA:BIT? 3, (@1101)
```

The acceptable range for the bit parameter is based on the channel width as shown below:

- BYTE (8-bit): <bit> can range from '0' to '7'
- WORD (16-bit): <bit> can range from '0' to '15'
- LWORD (32-bit): <bit> can range from '0' to '31'

The **SENSe** command differs from the **MEASure** command in that it will not change the direction (input or output) of the channel. If the channel is configured as an output, the **SENSe** command will return the value being driven.

Writing Digital Data

To write digital data, set the channel output parameters using the **SOURce** commands. For example, sending the following SCPI commands to a Digital I/O module in slot 1 sets a 32-bit channel to use normal polarity, with active drive and a 'set' output voltage of 4 volts.

```
CONF:DIG:WIDT LWOR, (@1201)
```

```
CONF:DIG:POL NORM, (@1201)
```

```
SOUR:DIG:DRIV ACT, (@1201)
```

```
SOUR:DIG:LEV 4, (@1201)
```

The width and polarity parameters apply to both input and output operations.

You can set a channel to output in either active drive or open collector configurations. When set to **ACTive**, the module drives the digital lines for both high and low. The voltage level that represents a logic '1' can be set using the **SOURce:DIGital:LEVel** command. Output voltages can range from 1.66 V (default) to 5 V.

When the channel is set to **OCOLlector**, lines are driven low, but set to high impedance (Hi-Z) when asserted. In the open collector mode, multiple lines can be connected together by providing external pull-ups.

NOTE

When using external pull-ups in the open collector mode, the outputs will not exceed 5 V.

Once a channel has been configured, write digital data to the channel using the **SOURce:DIGital:DATA** command.

```
SOUR:DIG:DATA:LWOR 26503,(@1201)
```

You may also use a hexadecimal format to represent values in the commands. For example, to send the decimal value of 26503 in hex use the command form:

```
SOUR:DIG:DATA:LWOR #h6787,(@1201)
```

NOTE

Writing to a channel automatically configures the channel as an output.

Note that the data should match the channel width configured using **CONFigure:DIGital:DATA:WIDTH** command. The data written is masked by the configured width so that any extra bytes will be discarded. For example: sending the value 65531 to a byte wide channel will result in the channel discarding the upper byte and outputting 251.

Channel Width and Polarity, Threshold, Level, and Drive

When the width of a channel is set to **WORD** or **LWORD**, the channel direction (input or output) of the channels spanned by the width is controlled by the channel in operation. That is, all grouped channels are automatically set to the same input or output operation.

Channel settings of polarity, threshold, level, and drive mode are unchanged when channels are combined. For example, consider the following command sequence.

```
CONF:DIG:POL NORM,(@1101)
```

```
CONF:DIG:POL INV,(@1102)
```

```
CONF:DIG:WIDT WORD,(@1101)
```

This command sequence sets the first 8 bits (channel 101) to normal polarity for input and output operations, set the next 8 bits (channel 102) to inverted polarity, and then combines the bits into a 16-bit channel. When this WORD channel is used, the first eight bits will input or output using normal polarity but the next 8 bits will read or written using inverted polarity.

Threshold, level, and drive settings all behave in the same manner as the polarity setting described above.

Handshaking

Handshaking provides a means to synchronize the input or output of digital data. By default, no handshaking is used and data is input or output as the command is executed. The handshake is configured per bank.

The L4450A provides a synchronous strobed handshake mode. You can use this mode with basic input and output operations. You must use this handshake mode to use buffered I/O (see “[Buffered I/O Operations](#)” on page 255).

The handshake is performed using three lines on each bank. The lines are labeled H0, H1, and H2. The function of each line is set by the input or output mode in use. Since there are only three handshake lines per bank, the SCPI handshake commands are only valid for the first channel in a bank. Once handshaking is enabled, it applies to the width of the first channel in the bank.

The three handshaking lines on each bank also differ slightly if you are using buffered ([page 255](#)) or unbuffered I/O operations. You can also perform unbuffered operations without any handshake. The function of each line for each mode of operation is defined in the table below.

	H0	H1	H2
Unbuffered Synchronous Input	I/O Direction (output)	Strobe (output)	Not Used (Hi-Z)
Unbuffered Synchronous Output	I/O Direction (output)	Strobe (output)	Not Used (Hi-Z)
Buffered Synchronous Input	Start/Stop (output)	Not Used (Hi-Z)	Input Strobe (input)

	H0	H1	H2
Buffered Synchronous Output (internal clock)	Start/Stop (output)	Strobe (output)	Not Used (Hi-Z)
Buffered Synchronous Output (external clock)	Start/Stop (output)	Not Used (Hi-Z)	Output Strobe (input)

The following handshake command sets the synchronous handshaking mode for the channels in bank 1.

```
CONF:DIG:HAND SYNC, (@1101)
```

This form of the handshaking command also allows you to optionally set the input threshold, output drive level, and polarity of all the handshake lines. For example, the following command sets bank 2 to use synchronous handshaking, with an input threshold of 2.5 V, an output drive level of 2.5 V, and normal polarity. Other parameters such as the handshake timing are set to default values (refer to the Programmer's Reference Help file on www.keysight.com/find/L4400 for details).

```
CONF:DIG:HAND SYNC, 2.5, 2.5, NORM, (@1201)
```

You can set parameters by using a sequence of commands instead of the `CONFfigure` macro command. For example, the following command sequence sets the handshaking mode to synchronous, the output drive to open collector, and the handshake rate to 1 MHz.

```
CONF:DIG:HAND:MODE SYNC, (@1101)
```

```
CONF:DIG:HAND:DRIV OCOL, (@1101)
```

```
CONF:DIG:HAND:RATE 1000000, (@1101)
```

Setting the Handshake Line Parameters

You can set the handshake lines' input threshold, output drive mode, and output drive voltage. These settings affect all the handshake lines in the bank. Handshake line polarity can be set for each individual handshake line.

For example, you can invert the polarity of the handshake line H1 on bank 2 with the following command.

```
CONF:DIG:HAND:POL INV, H1, (@1201)
```

You can set the output drive mode, output voltage, and input threshold for all handshake lines in each bank. For example, the following commands set the drive

mode to active, the drive voltage to 4.5 V, and the input threshold to 1.0 V on bank 2.

```
CONF:DIG:HAND:DRIV ACT, (@1201)
```

```
SOUR:DIG:HAND:LEV 4.5, (@1201)
```

```
SENS:DIG:HAND:THR 1, (@1202)
```

NOTE

The settings for drive mode, output drive level, and input threshold also apply to the bank's interrupt line.

NOTE

When using external pull-ups in the open collector mode, the outputs will not exceed 5 V.

Synchronous Handshake Mode

In the synchronous handshake mode, a strobe or clock signal is used to transfer data to or from an external device. The strobe line (H1) is an output and is pulsed once for each transfer.

Synchronous Unbuffered Inputs For synchronous handshake unbuffered inputs the H0 line indicates the direction of the transfer. This line is set high to indicate an input operation. The H0 line will remain in the high state until the L4450A direction is changed. The H1 line is the strobe output line. The H2 line is not used and is set to high impedance.

The timing of the input operation is controlled by the T_{CYCLE} parameter set using the `CONFigure:DIGital:HANDshake:RATE` command. This setting affects strobe width, memory clock rate, as well as the setup and hold times. Alternatively, the reciprocal form of the command `CONFigure:DIGital:HANDshake:CTIME` can be used to specify the speed in terms of time instead of a rate. T_{CYCLE} begins when the L4450A executes one of the input commands.

The timing should be such that the device sending the data ensures the data lines are valid prior to T_{SETUP} time. The trailing edge of the strobe line indicates the L4450A will latch the data within the T_{HOLD} time. T_{SETUP} is 90ns and T_{HOLD} is 0ns. Since $T_{\text{HOLD}} = 0\text{ns}$, the sending device can use the trailing edge of the strobe to initiate a change in the data lines.

A synchronous unbuffered input is shown in the diagram below (default handshake line polarity).

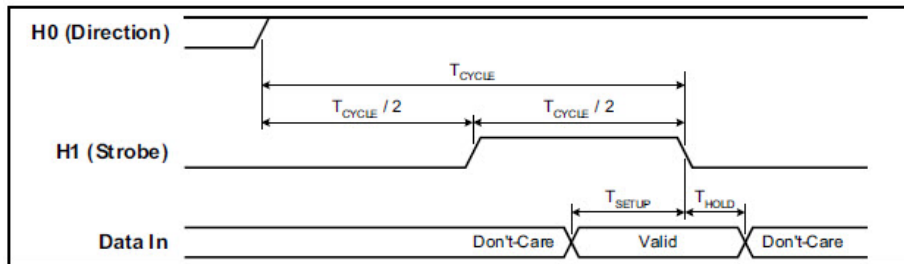

For example, the following SCPI commands set the L4450A to have a 16-bit input using synchronous handshake. Two data inputs are then performed and the strobe line is pulsed for each query. The I/O direction line is set high following the first `SENSe:DIGital:DATA:WORD?` query and remains high until the digital channel is reset or reconfigured.

```
CONF:DIG:WIDT WORD, (@1101)
```

```
CONF:DIG:DIR INP, (@1101)
```

```
CONF:DIG:HAND SYNC, (@1101)
```

```
SENS:DIG:DATA:WORD? (@1101)
```

```
SENS:DIG:DATA:WORD? (@1101)
```

Synchronous Unbuffered Outputs For synchronous handshake unbuffered outputs, the H0 line indicates the direction of the transfer. This line is set low to indicate an output operation. The H0 line will remain in the low state until the L4450A direction is changed. The H1 line is the strobe output line.

When the L4450A executes an output command, it sets the data lines and waits for $T_{\text{CYCLE}}/2$ before asserting the strobe line. The leading edge of the strobe indicates the data is valid. The strobe line is asserted for $T_{\text{CYCLE}}/2$ and then de-asserted. The H2 line is not used and is set to high impedance.

The timing of the output operation is controlled by the T_{CYCLE} parameter set using the `CONFigure:DIGital:HANDshake:RATE` command. This setting affects strobe width, memory clock rate, as well as the setup and hold times. Alternatively, the reciprocal form of the command `CONFigure:DIGital:HANDshake:CTIME` can be used to specify the speed in terms of time instead of a rate. The timing should be

set such that the device receiving the data can read the data lines during the $T_{\text{CYCLE}}/2$ time.

A synchronous unbuffered output is shown in the diagram below (default handshake line polarity).

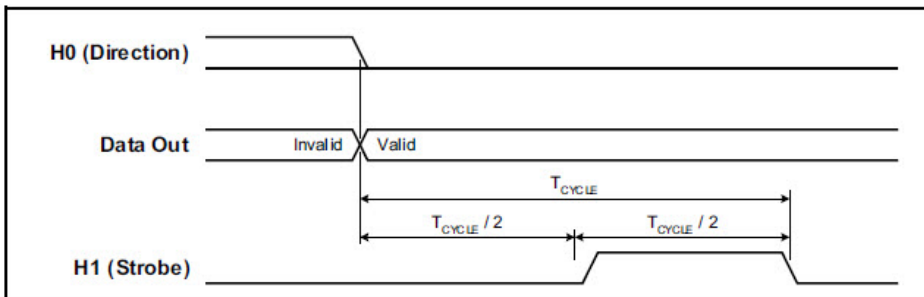

For example, the following SCPI commands set the L4450A to have a 16-bit output using synchronous handshake. Two data outputs are then performed and the strobe line is pulsed for each. The I/O direction line is set low following the first `SOURce:DIGital:DATA:WORD` command and remains low until the digital channel is reset or reconfigured.

```
CONF:DIG:WIDT WORD, (@1101)
CONF:DIG:DIR OUTP, (@1101)
CONF:DIG:HAND SYNC, (@1101)
SOUR:DIG:DATA:WORD #hFFFF, (@1101)
SOUR:DIG:DATA:WORD #h4DB5, (@1101)
```

Synchronous Buffered Inputs You can use synchronous mode handshake with buffered (memory) input operations. (Buffered operations are described in more detail beginning on [page 255](#).) For buffered input operations, the H0 line acts as a start/stop line. This line will be set high when the memory input command is executed and will return low when the memory input operation has completed. The H1 line is not used and is set to high impedance.

An external strobe input on the H2 line controls the pace of memory transfers. The sending device must ensure the data is valid before the T_{SETUP} and stays valid until after T_{HOLD} . T_{SETUP} is 30 ns and T_{HOLD} is 55 ns.

A synchronous buffered input using an external clock is shown in the diagram below (default handshake line polarity).

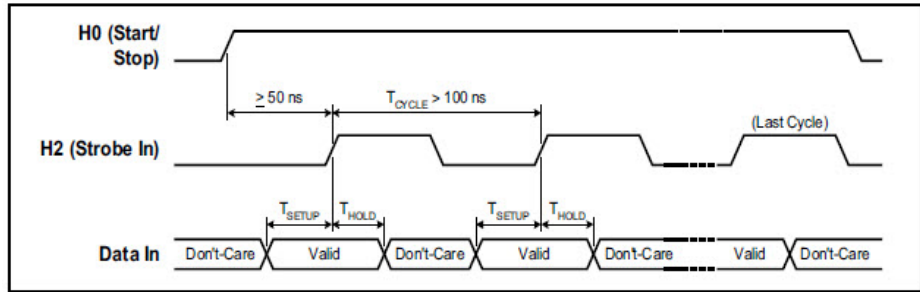

For example, the following SCPI commands set the L4450A to have an 8-bit input using synchronous handshake with an external strobe input. The number of bytes to read into memory is set to infinite (continuous reading into memory until the memory is stopped). The memory is enabled and then triggered. The start/stop line is set high following the first byte handshake and remains high until the last byte is captured.

```
CONF:DIG:WIDT BYTE, (@1101)
CONF:DIG:DIR INP, (@1101)
CONF:DIG:HAND SYNC, (@1101)
SENS:DIG:MEM:SAMP:COUN 0, (@1101)
SENS:DIG:MEM:ENAB ON, (@1101)
SENS:DIG:MEM:STAR (@1101)
```

Synchronous Buffered Outputs You can use synchronous mode handshake with buffered (memory) output operations. (Buffered operations are described in more detail beginning on [page 255](#).) For buffered output operations, the H0 line acts as a start/stop line. This line will be set high when the memory output command is executed by the L4450A and will return low when the memory output operation has completed.

Synchronous memory output operations can be paced using either the internal strobe or an external strobe.

When using the internal strobe, the H1 line is the strobe output line. The timing of the output operation when using the default `INTERNAL` clock is controlled by the `CONFIGure:DIGital:HANDshake:RATE` command. This setting affects strobe width,

memory clock rate, as well as the setup and hold times. Alternatively, the reciprocal form of the command `CONFigure:DIGital:HANDshake:CTIME` can be used to specify the speed in terms of time instead of a rate. The timing should be set such that the device receiving the data can latch the data lines during the T_{CYCLE} time.

The receiving device should detect the leading edge of the strobe line, wait for the L4450A to set the data (T_{PD}) and then latch the data. Latching the data on the trailing edge of the strobe is recommended, however, you can the data following T_{PD} . T_{PD} ranges from -23 to 23 ns.

A synchronous buffered output using the internal clock is shown in the diagram below (default handshake line polarity).

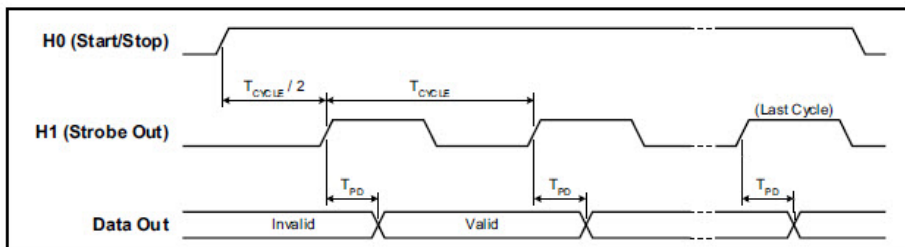

Optionally, you can provide an external strobe input on the H2 line to control the memory transfers. If you pace the memory inputs from an external clock, the L4450A will sense the leading edge of the strobe and set the data. The data will be valid after T_{PD} and the receiving device may latch the data. T_{PD} ranges from 140 ns to 60 ns. The maximum T_{PD} of 140 ns limits operation in this mode to 7 MHz.

A synchronous buffered output using an external clock is shown in the diagram below (default handshake line polarity).

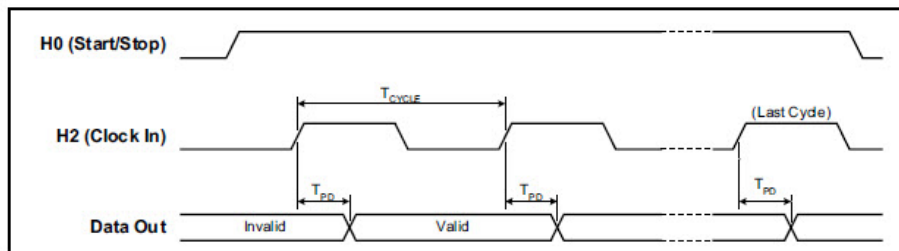

For example, using the internal strobe, the following SCPI commands set the L4450A to have a 32-bit output using synchronous handshake. The number of times to output the traces is set to 4. A trace is then loaded into memory and assigned to the channel. The memory is enabled and then triggered. The start/stop line is set high following the first byte handshake and remains high until the last byte is output.

```
CONF:DIG:WIDT LWOR, (@1101)
CONF:DIG:DIR OUTP, (@1101)
CONF:DIG:HAND SYNC, (@1101)
SOUR:DIG:MEM:NCYC 4, (@1101)
TRAC:DATA:DIG:LWOR (@1101), mytrace, #hFFEEFFEE, #hBCBC9999
SOUR:DIG:MEM:TRAC mytrace, (@1101)
SOUR:DIG:MEM:ENAB ON, (@1101)
SOUR:DIG:MEM:STAR (@1101)
```

Using an external strobe, the following SCPI commands set the L4450A to have an 8-bit output using synchronous handshake with an external strobe input. The number of times to output the traces is set to infinite (continuous output until the memory is stopped). The memory is enabled and then triggered. The start/stop line is set high following the first byte handshake and remains high until the last byte is output.

```
CONF:DIG:WIDT BYTE, (@1101)
CONF:DIG:DIR OUTP, (@1101)
CONF:DIG:HAND SYNC, (@1101)
CONF:DIG:HAND:SYNC:STR:SOUR EXT, (@1101)
SOUR:DIG:MEM:NCYC 0, (@1101)
TRAC:DATA:DIG:BYTE (@1101), mytrace, 260, 139
SOUR:DIG:MEM:TRAC mytrace, (@1101)
SOUR:DIG:MEM:ENAB ON, (@1101)
SOUR:DIG:MEM:STAR (@1101)
```

Buffered I/O Operations

Each of the two banks on the L4450A has its own memory that can be used to store patterns to output (traces) or to store input patterns. The width of the first channel in each bank controls the width of the memory operations. Memory may be used as:

- 64K x 8 bits
- 64K x 16 bits
- 32K x 32 bits

Buffered (Memory) Output

Each bank on the L4450A has its own memory for use in buffered transfers. Changing a bank from an input to an output will clear all memory for that bank. For buffered outputs, you download “traces” of digital data to the memory. Multiple traces (up to 32) can be downloaded into each bank. A specified trace is then output using the handshaking parameters set.

The general steps to output from memory are:

- 1 Set the channel width and direction.
- 2 Set the handshake mode.
- 3 Set the trigger source.
- 4 Set the number of times to output the trace.
- 5 Load the trace(s) into memory.
- 6 Set which trace to use.
- 7 Enable the memory.
- 8 Trigger the output.

Set the channel width and direction. Use the `SOURCE:DIGital:DATA` command to set the channel width and set the channel as an output. Additionally, the data specified in the command will be the initial state of the data lines before the memory operation begins.

Set the handshake mode. You must use synchronous handshaking mode. You can use either an internal or external strobe (clock) to pace the outputs. Handshaking is described in more detail on [page 247](#).

Set the trigger source. By default, the trigger source is set to use a software trigger. You can also use one of the interrupt lines (see [page 259](#)) as a trigger source.

Set the number of times to output the trace. Each trace can be output once, multiple times, or infinitely. The `SOURce:DIGital:MEMory:NCYCles` command sets the number of times to output the trace. If not set to infinite, you can output the trace from 1 to 255 times (the output is controlled by the handshake).

Load the trace(s) into memory. Named traces are downloaded using the `TRACe:DATA:DIGital` command. The channel width used should match the width of the channel set in step 1. If you change the width of a bank, all traces in memory are cleared. The trace names must start with a character and may be up to 12 characters in length. The trace name used must be unique to the bank. Up to 32 traces may be downloaded.

Traces can be added or deleted only when memory is disabled. Memory output cannot be enabled unless the bank has a trace assigned to it.

For example, the following commands load two traces into memory for bank 1. In this example, each byte of the `LWORd` to output is sent as a separate byte.

```
TRAC:DATA:DIG:LWOR (@1101), MyTrace1, 255, 200, 128, 0
```

```
TRAC:DATA:DIG:LWOR (@1101), MyTrace2, 254, 192, 64, 32
```

You can also send trace data in IEEE-488 block format using this command.

The L4450A also has two special built-in traces for your use. You can generate and download a count-up trace and a walking 1's pattern using the `TRACe:DATA:DIGital:FUNCTion` command. See the Programmer's Reference Help file on www.keysight.com/find/L4400 for more details.

NOTE

You can generate a count-down or walking zero pattern by inverting the data line polarity.

Set which trace to use. The `SOURce:DIGital:MEMory:TRACe` command assigns the desired trace to the bank. This command allows you to switch between the traces pre-loaded into the bank's memory.

Enable the memory. Enable the memory on the bank using the `SOURce:DIGital:MEMory:ENABle` command. This command sets the selected trace to be the output and puts the bank in the wait-for-trigger state.

Trigger the output. When the default trigger source is used, the `SOURce:DIGital:MEMory:STARt` command triggers the output. The selected trace will be output when the handshake occurs.

If the trigger source has been set to one of the interrupt lines (see [page 259](#)), the output will wait for the interrupt to occur and then the handshake to occur before the trace is output.

You can also output the trace one sample at a time on the data lines using the `SOURce:DIGital:MEMory:STEP` command. This command outputs one sample and then puts the memory in the stopped state. The STEP command also overrides the interrupt line so it can be used to trigger a transfer even if the interrupt line is set to be the trigger source.

Deleting Traces

You can delete traces in memory to recover the memory space. Use the `TRACe:DELete:NAME` command to delete a specific trace. Note that deleting a specific trace does not de-fragment the memory. You can delete all traces using the `TRACe:DELete:ALL` command.

Buffered (Memory) Input

Each bank on the L4450A has its own memory for use in buffered transfers. Changing a bank from an output to an input will clear all memory for that bank. The general steps to use input memory are:

- 1 Set the channel width and parameters.
- 2 Set the handshake mode.
- 3 Set the number of samples to collect.
- 4 Start the capture.
- 5 Check the status of the transfer.
- 6 Retrieve the captured data.

Set the channel width and direction. Use the `CONFIgure:DIGital` command to set the channel width, direction, thresholds, and polarity. See [page 244](#) for basic input operations.

Set the handshake mode. You must use synchronous handshaking mode. Handshaking is described in more detail on [page 247](#).

Set the number of samples to collect. The `SENSe:DIgital:MEMory:SAMPle:COUNT` command sets the number of samples to capture. If you set the number of counts to infinite (0 = default), the bank will capture data until a STOP is received. Older samples are overwritten if memory gets full. Allowed sample counts depend upon the channel width as follows:

- BYTE (8-bit) 1 to 65535
- WORD (16-bit) 1 to 65535
- LWORD (32-bit) 1 to 32767

Start the capture. The `SENSe:DIgital:MEMory:START` command sets the channel to begin the data capture. The capture begins when the handshake occurs.

Check the status of the transfer. You can use the `SENSe:DIgital:MEMory:DATA:POINTs?` query to return the number of samples currently in memory.

Retrieve the captured data. Set the desired memory retrieval format using the `SENSe:DIgital:DATA:FORMat` command. You can set the memory to be read as either `LIST` or `BLOCK`. The `LIST` parameter (default) returns the data as comma separated ASCII values. `BLOCK` returns the data in IEEE-488 block format.

Before you can read the data in memory, you must stop the memory operations using the `SENSe:DIgital:MEMory:ENABle OFF` command.

Read all the captured data using the `SENSe:DIgital:MEMory:DATA:ALL?` query. This performs a non-destructive read of all data in the bank's memory.

To read specific captures, use the `SENSe:DIgital:MEMory:DATA?` form of the command. This command takes index and count parameters to specify which data to retrieve. The oldest data in memory has an index of '0'. The count specifies the number of samples to read. `count + index` must be less than the number of captured points.

Both these data reads are non-destructive to the bank memory. To clear the memory for new data, send the `SENSe:DIgital:MEMory:CLEar` command.

Interrupt Lines

Each bank has an interrupt line that can be used with memory input or output operations. When a bank is set to input data, the interrupt line is an output. When a bank is set to output data, the interrupt line is set to be an input. You can set the polarity of the interrupt line for input and output operations using the `CONFigure:DIGital:INTerrupt:POLarity` command.

You can configure the interrupt line drive mode, output drive level, and input threshold. These parameters are set for both the handshake lines and interrupt line on a bank. See [page 248](#) for details about setting these parameters.

Memory Output Operations

For memory output operations, the interrupt line is sensed and can be used to start or stop memory output operations. This provides a hardware means to control the data output.

The `SOURce:DIGital:INTerrupt:MODE` command sets how the bank will behave when using memory output. The mode can be set to one of three values:

- **START**: The memory output will begin on the rising edge of the interrupt line.
- **STOP**: The memory output is halted on the rising edge of the interrupt line.
- **GATE**: The interrupt line acts as a gate for the memory output. The bank can output when the interrupt line is asserted, and will stop when the interrupt line is de-asserted.

When you have set the polarity and mode, enable the interrupt using the `SOURce:DIGital:INTerrupt:ENABLE` command.

Memory Input Operations

For memory input operations, the interrupt line is an output and is set on a pattern match or when the memory has been filled. You can set the interrupt line to be driven or open collector using the `SENSe:DIGital:HANDshake:DRIVE` command.

NOTE

The settings for drive mode, output drive level, and input threshold also apply to the bank's handshake lines.

When set to **ACTive** the interrupt line will be driven by the instrument. The high output voltage is set for both the handshaking and interrupt line on a bank with the **SOURce:DIGital:HANDshake:LEVel** command.

When set to **OCOLlector** the interrupt line will be driven low, but will go to high impedance mode when in the 'High' state. The open collector mode requires external pull-ups.

The **SENSe:DIGital:INTerrupt:MODE** command sets the condition that will cause the interrupt to be asserted. When set to **MFULL** the interrupt is given when the memory is full. When set to **COMPare** the interrupt is asserted when the pattern is detected (page 261). When either condition is removed, the interrupt is de-asserted.

The interrupt line is enabled by the **SENSe:DIGital:INTerrupt:ENABle** command and the status can be checked using the SCPI Status System (refer to the Programmer's Reference Help file on www.keysight.com/find/L4400).

Byte Ordering

When using buffered memory operations, the width of the data sets how the memory data is interpreted. Changing the width of the first channel in a bank invalidates any traces stored or captured.

Output Operations For output operations (see page 255), traces are put into memory using the **TRACe:DATA:DIGital** command.

For output operations, the data stored in memory is output as follows:

- **BYTE** output - first byte in memory on the first handshake, next byte in memory on the second handshake, and so on.
- **WORD** output - first and second byte in memory on the first handshake, next two bytes in memory on the second handshake, and so on.
- **LWORD** output - first four bytes in memory on the first handshake, next four bytes in memory on the second handshake, and so on.

Note that for **WORD** outputs the first byte in memory is considered the most significant byte and is output on the upper bits (15 through 8). For **LWORD** outputs the first byte is output on bits 31 through 24.

You can change the byte order reported using the **FORMat:BOReDer** command. This command allows you to swap the most-significant and least-significant byte

ordering for all data transfer operations. The command is applied globally and cannot be assigned to an individual slot or channel.

Input Operations For input operations (see [page 257](#)), bytes are read into memory as follows:

- **BYTE** input - the first byte in memory was read on the first handshake, the next byte in memory was read on the second handshake, and so on.
- **WORD** input - first and second byte in memory were read on the first handshake, next two bytes in memory were read on the second handshake, and so on.
- **LWORD** input - first four bytes in memory were read on the first handshake, next four bytes in memory were read on the second handshake, and so on.

Note that for **WORD** inputs the first byte in memory is considered the most significant byte and was read on the upper bits (15 through 8). For **LWORD** inputs the first byte was read on bits 31 through 24.

Pattern Matching

Pattern matching can be used on input channels only. Pattern matching can be done with or without handshaking. When a pattern match occurs, the L4450A can set an interrupt line or system alarm. A pattern match can also be used to start or stop a buffered (memory) transfer.

Pattern matching is done on a per bank basis and always starts at the first channel of a bank and works up to encompass the configured width of the channel.

Patterns are set up and enabled using the **CALCulate** subsystem of SCPI commands. For example, the following commands set up a pattern match (#HF00F) and assert the interrupt line when the input pattern is equal to the match pattern.

```
CONF:DIG:WIDT WORD, (@1101)
CALC:COMP:DATA #HF00F, (@1101)
CALC:COMP:TYPE EQUAL, (@1101)
SENS:DIG:INT:MODE COMP, (@1101)
SENS:DIG:INT:ENAB ON, (@1101)
CALC:COMP:STAT ON, (@1101)
```

Once the pattern matching state is turned on, the L4450A polls for the pattern #HF00F to appear on the data lines of channel 101. The interrupt line will be asserted when the pattern is matched. In the example above the last command, `CALCulate:COMPare:STATe`, also sets the mainframe alarm on a pattern match.

You can use pattern matching to start or stop a buffered (memory) input transfer. When the desired pattern is found, the L4450A can be set to start or stop a capture.

For example, the following commands establish a byte pattern match on channels 101 and 201. When the pattern is found, 200 samples are captured.

```
CONF:DIG:WIDTH BYTE, (@1101,1201)
CALC:COMP:DATA:BYTE 140, (@1101,1201)
CALC:COMP:STAT ON, (@1101,1201)
DIG:MEM:SAMP:COUN 200, (@1101,1201)
DIG:MEM:COMP:ACT STAR, (@1101,1201)
DIG:MEM:ENAB ON, (@1101,1201)
```

Counter

The L4450A has two 10 MHz frequency counter/totalizer measurement input channels. The counters can operate in two general modes: Totalizer mode, and Initiated Measurement mode. In the totalizer mode, the counter acts as a basic totalizer. In the initiated measurement mode, the counter can make frequency, period, duty cycle, and pulse width measurements.

Totalizer Mode

Totalizer mode is the default operating mode for the counters. When the counter is configured for **TOTALizer** mode, it automatically starts running. The totalized count can be read, reset, scanned, and monitored.

The simplest way to take a totalizer measurement is to use the `MEASure` form of the command. For example, the following command configures the totalizer on the first bank, initiates the measurement, and returns the result. The data is returned in a floating point format.

```
MEAS:COUN:TOT? READ, (@1301)
```

You can also reset the totalizer count by setting the parameter to `RRESet`. For example, the following command configures the totalizer on the first bank,

initiates the measurement, and returns the result. The totalize count is reset when the data is read.

`MEAS:COUN:TOT? RRES, (@1301)`

Totalizer counts begin as soon as the channel is configured for the totalize measurement. You can stop a count by sending `SENSe:COUNter:ABORt` command and restart the count using the `SENSe:COUNter:INITiate` command.

The slope of the edges being counted can be configured using the `SENSe:COUNter:SLOPe` command. By default, when started, the totalizer counts rising edges.

Additionally, you can control when the edges are counted by setting the gate source to external and providing a gate signal on the gate input. In external gate mode the counter totalizes when the gate is asserted. The gate time setting controls how long the counter totalizes. Once the external gate has been de-asserted a new measurement must be armed via the `SENSe:COUNter:INITiate` command. The figure below shows an externally gated totalizer measurement. The number of totalized counts is '5' in this particular example.

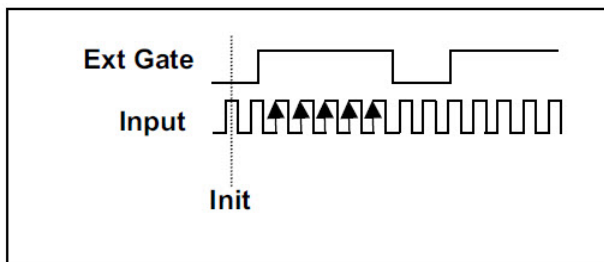

Initiated Measurement Mode

Measurements such as frequency, period, duty cycle, and pulse width require an initiate command and a gate. The `SENSe:COUNter:INITiate` command is used to initiate (arm) the measurement. The measurement is gated by either an internal (default) or external gate source. For measurements the external gate acts like an external trigger which triggers the internal gate timer.

The gate source is set using the `SENSe:COUNter:SOURce` command. The default gate source is `INTerna1`. The gate is the aperture over which the signal data is gathered. When the gate is internal, the measurement begins as soon as the `INITiate` command is received.

Since the measurements are all derived from the same basic measurement, you can retrieve the measured frequency, period, duty-cycle, and pulse width from the same initiated and gated measurement. For example, the following commands set the counter to measure the input signal for 1 ms using the internal gate. The frequency, period, duty cycle, and pulse width are returned as floating point numbers.

```
CONF:COUN:FREQ 1e-3, (@1301)
```

```
SENS:COUN:INIT (@1301)
```

```
SENS:COUN:FREQ? (@1301)
```

```
SENS:COUN:PER? (@1301)
```

```
SENS:COUN:PWID? (@1301)
```

```
SENS:COUN:DCYC? (@1301)
```

The `CONFigure:COUNTER:FREQUency` command parameter sets the internal gate time (to 1e-3 or 1 ms in the above example). You can also set the gate time using the `SENSe:COUNTER:GATE:TIME` command.

Clock

The general-purpose clock output is derived from the internal time base. The output clock is divided down from the time base clock such that:

$$\text{Clock Output (Hz)} = (\text{time base frequency}) / (\text{divisor})$$

The time base frequency is 40 MHz. The divisor can be an integer from 2 to 4⁶ providing a range of 20 MHz to 10 Hz for the clock output. The valid values for the clock output rate are: 20 MHz, 13.33 MHz, 10 MHz, 8 MHz, 6.667 MHz, ... 10 Hz. The clock output frequency will round to the nearest achievable frequency.

The commands used to control the clock output are:

```
SOUR:MOD:CLOC:FREQ {<freq>|MIN|MAX|DEF},<s1ot>
```

```
SOUR:MOD:CLOC {OFF|ON|0|1},<s1ot>
```

You can obtain the rounded value of the currently set clock frequency using the following query.

```
SOUR:MOD:CLOC:FREQ?
```

You can also set the logic “high” voltage level for external clock output. For example, the following command sets the output clock level to 4.5 V.

SOUR:MOD:CLOC:LEV 4.5, 1

L4450A D-Sub Connectors

The L4450A uses two D-sub 78-pin female connectors. Each connector provides contains one bank of the module. As viewed from the rear panel, the connectors and their banks are shown below.

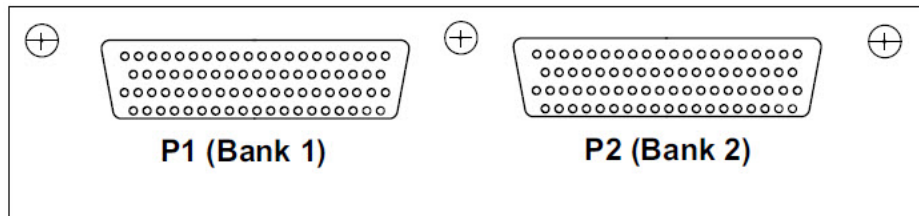

As viewed from the rear panel, the pins in each connector are numbered as shown below.

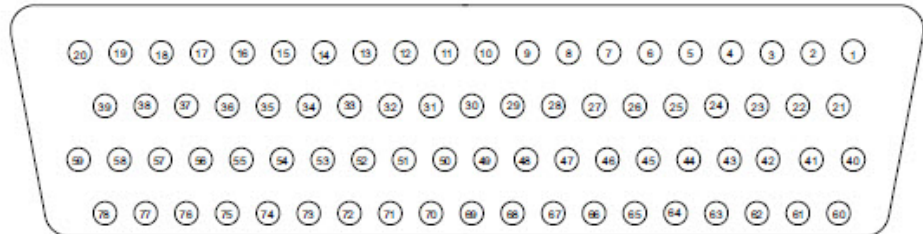

P1 (Bank 1) Connector Pin Assignments

Pin	Signal		Pin	Signal		Pin	Signal		Pin	Signal	
1	GND	C H 3 0 1	21	GND	C H 1 0 4	40	18	C H 1 0 3	60	8	CH102
2	CNTR		22	27		41	GND		61	GND	
3	GND		23	GND		42	17		62	NC	
4	GATE		24	26		43	GND		63	GND	
5	GND		25	GND		44	16		64	7	C H 1 0 1
6	INTR		26	25		45	GND		65	GND	
7	GND		27	GND		46	15		66	6	
8	H2		28	24		47	GND		67	GND	
9	GND		29	GND		48	14		68	5	
10	H1		30	23		49	GND		69	GND	
11	GND		31	GND		50	13		70	4	
12	H0		32	22	C H 1 0 3	51	GND	C H 1 0 2	71	GND	
13	GND		33	GND		52	12		72	3	
14	31	C H 1 0 4	34	21		53	GND		73	GND	
15	GND		35	GND		54	11		74	2	
16	30		36	20	55	GND	75	GND			
17	GND		37	GND	56	10	76	1			
18	29		38	19		57	GND		77	GND	
19	GND		39	GND		58	9		78	0	
20	28					59	GND				

P2 (Bank 2) Connector Pin Assignments

Pin	Signal		Pin	Signal		Pin	Signal		Pin	Signal	
1	GND	C H 3 0 2	21	GND	C H 2 0 4	40	18	C H 2 0 3	60	8	CH202
2	CNTR		22	27		41	GND		61	GND	
3	GND		23	GND		42	17		62	CLK	
4	GATE		24	26		43	GND		63	GND	
5	GND		25	GND		44	16		64	7	C H 2 0 1
6	INTR		26	25		45	GND		65	GND	
7	GND		27	GND		46	15		66	6	
8	H2		28	24		47	GND		67	GND	
9	GND		29	GND		48	14		68	5	
10	H1		30	23		49	GND		69	GND	
11	GND		31	GND		50	13		70	4	
12	H0		32	22	C H 2 0 3	51	GND	C H 2 0 2	71	GND	
13	GND	C H 2 0 4	33	GND		52	12		72	3	
14	31		34	21		53	GND		73	GND	
15	GND		35	GND		54	11		74	2	
16	30		36	20	55	GND	75	GND			
17	GND		37	GND	56	10	76	1			
18	29		38	19	57	GND	77	GND			
19	GND		39	GND	58	9	78	0			
20	28				59	GND					

34950T Terminal Block

The optional 34950T terminal block has screw type connections and the terminal are labeled with the channel and bit information.

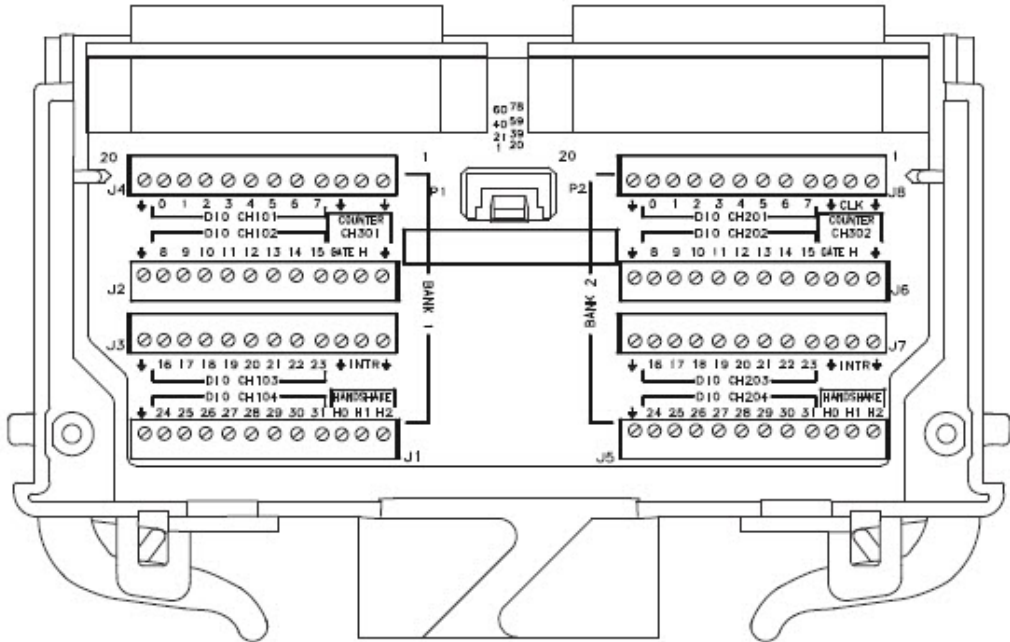

Figure 8-1 L4450A Terminal Block.

9 L4451A 4-Channel Isolated D/A Converter with Waveform Memory

L4451A 4-Channel Isolated D/A Converter with Waveform Memory	270
L4451A SCPI Command Summary	273
L4451A Example Program Segments	276
L4451A Simplified Block Diagrams	279
L4451A D-Sub Connector Pinout	280
34951T Terminal Block	281

L4451A 4-Channel Isolated D/A Converter with Waveform Memory

The L4451A 4- Ch Isolated D/A module (DAC module) has four independent, isolated DAC channels that output DC voltage up to $\pm 16\text{V}$ or DC current up to $\pm 20\text{ mA}$. Since the DACs are electrically isolated, you can stack or combine multiple DACs to have up to $\pm 64\text{ V}$ on a module. You can control each channel manually, or use the onboard memory to store multiple sequenced points.

Level Output Mode

The module can generate voltages between $- 16\text{ V DC}$ and $+16\text{ V DC}$ at $500\text{ }\mu\text{V}$ resolution on any channel. Each channel configured for voltage output has hardware remote- sensing capability to ensure that an accurate voltage is present at the load. With the remote sensing feature, the DAC channel outputs an additional voltage to compensate for the voltage drop in the test leads. Thus, using the sense connections, the load voltage equals the programmed voltage as long as the resistance in each sense lead is less than 2.5Ω and the maximum voltage drop in the output leads is 0.5 volts .

NOTE

To ensure that an accurate voltage is present at the loads, it is recommended that you use remote-sensing. However, if remote-sensing is not used, do not connect loads or cables to the remote-sensing terminals (H Sense and L Sense).

When using the remote- sensing feature, connect sense wires from the load to the High Sense and Low Sense terminals for the desired channels.

Each channel can also generate current between $- 20\text{ mA}$ and $+20\text{ mA}$ at 630 nA resolution. When outputting current the High Sense and Low Sense terminals are not used and are opened. For protection, each channel incorporates a fuse that will open at greater than 20 mA . If an overload condition exists, the fuse will open, but no error or SRQ will be generated. To reset the fuse, remove the overload condition and wait a few minutes for the fuse to cool.

Waveform (Trace) Mode

Using the internal waveform point storage, you can output provided sine, square, or ramp and triangle wave shapes, or define your own wave shape with up to

512,000 points. The module can output points with a settling time of 40 μ s and a 200 kHz point- to- point update rate.

The on- board memory provides storage for you to create up to 32 voltage or current waveforms. You can apply a different waveform to each channel to output. Or you can apply the same waveform to more than one channel. For each channel you can designate the gain, frequency, and/or offset for its output.

The waveforms are stored in instrument memory. Therefore, whenever power is cycled, the volatile memory empties of data it has contained.

The waveform feature of the L4451A is not intended as a full- featured substitute for a function generator, but as a means of storing point- to- point updates.

Clock In

You can configure each DAC channel on the instrument to synchronize off either an internally- generated 20 MHz clock or the positive edge of an external user- supplied clock.

An external clock must be less than 10 MHz or indeterminate behavior will result. Additionally, the maximum point- to- point update rate of the DACs is 200 kHz. If you configure a DAC to run off an external clock, you will need to ensure that the correct clock divisor is also configured for that DAC. For example, if you supply a 10 MHz external clock, the minimum clock divisor is 50 because the maximum update rate is 200 kHz. If a clock divisor less than the minimum is configured, indeterminate behavior will result. Thresholds for the external clock input are 5 V TTL tolerant.

Clock Out

There is one clock output on the DAC module, which you can configure to output at frequencies up to 10 MHz. Since it uses a 16- bit clock divisor, the available output frequencies range in steps of $20 \text{ MHz}/2^{16}$ with a minimum output frequency of 305 Hz. The output impedance of the Clock Out is 50 Ω .

NOTE

The line between external Clock Out and external Clock In is shared. Use the external Clock Out to provide the external Clock In signal. However, both a user-supplied external clock and the module's Clock Out cannot drive the line at the same time.

Trigger In

You can configure each DAC on the module to trigger off an externally provided 'Trigger In' that has a pulse width greater than 100 ns. The Trigger In line is 5V TTL tolerant.

Trigger Out

The DAC module can source a TTL level Trigger Out. Trigger Out has a pulse width between 5 and 10 μ s.

NOTE

The line between external Trigger Out and external Trigger In is shared. You can use the external Trigger Out to provide the external Trigger In signal. However, both a user-supplied external trigger and the L4451A Trigger Out cannot drive the line at the same time.

L4451A SCPI Command Summary

Table 9-1 lists the instrument- specific SCPI commands that apply to the L4451A 4- Channel Isolated D/A Converter instrument. Table 3-3 (Chapter 3) lists the SCPI commands that apply to all L4400 series instruments.

For complete information on all SCPI commands, refer to the Programmer's Reference at www.keysight.com/find/L4400.

Table 9-1 L4451A SCPI Command Summary.

Subsystem	Commands
SOURce (DAC Configuration)	SOURce:CURRent[:LEVel] {<current> MIN MAX DEF}, (@<ch_list>)
	SOURce:CURRent[:LEVel]? [{MIN MAX},] (@<ch_list>)
	SOURce:FUNCTion:TRIGger:SOURce {IMMediate MANual EXternal}, (@<ch_list>)
	SOURce:FUNCTion:TRIGger:SOURce? (@<ch_list>)
	SOURce:MODE {VOLTage CURRent}, (@<ch_list>)
	SOURce:MODE? (@<ch_list>)
	SOURce:MODule:CLOCK:FREQuency {<frequency> MIN MAX DEF}, 1
	SOURce:MODule:CLOCK:FREQuency? [{MIN MAX},] 1
	SOURce:MODule:CLOCK:STATe {OFF ON 1}, 1
	SOURce:MODule:CLOCK:STATe? 1
	SOURce:MODule:TRIGger:EXternal:IMMediate 1
	SOURce:MODule:TRIGger:OUTPut {OFF ON 1}, 1
	SOURce:MODule:TRIGger:OUTPut? 1
	SOURce:VOLTage[:LEVel] {<voltage> MIN MAX DEF}, (@<ch_list>)
	SOURce:VOLTage[:LEVel]? [{MIN MAX},] (@<ch_list>)

Subsystem	Commands	
<p>SOURce (Trace Waveform Configuration)</p>	<p>SOURce:FUNCTion:CLock:EXternal:DIVisor {<value> MIN MAX DEF}, (@<ch_list>)</p> <p>SOURce:FUNCTion:CLock:EXternal:DIVisor? [{MIN MAX},] (@<ch_list>)</p> <p>SOURce:FUNCTion:CLock:SOURce {INTERNAL EXTERNAL STEP}, (@<ch_list>)</p> <p>SOURce:FUNCTion:CLock:SOURce? (@<ch_list>)</p> <p>SOURce:FUNCTion:CURRent:GAIN {<gain> MIN MAX DEF}, (@<ch_list>)</p> <p>SOURce:FUNCTion:CURRent:GAIN? [{MIN MAX},] (@<ch_list>)</p> <p>SOURce:FUNCTion:CURRent:OFFSet {<offset> MIN MAX DEF}, (@<ch_list>)</p> <p>SOURce:FUNCTion:CURRent:OFFSet? [{MIN MAX},] (@<ch_list>)</p> <p>SOURce:FUNCTion:ENABle {OFF ON 1}, (@<ch_list>)</p> <p>SOURce:FUNCTion:ENABle? (@<ch_list>)</p> <p>SOURce:FUNCTion:FREQuency {<frequency> MIN MAX DEF}, (@<ch_list>)</p> <p>SOURce:FUNCTion:FREQuency? [{MIN MAX},] (@<ch_list>)</p> <p>SOURce:FUNCTion:HALT (@<ch_list>)</p> <p>SOURce:FUNCTion:SAMple:PERiod {<period> MIN MAX DEF}, (@<ch_list>)</p> <p>SOURce:FUNCTion:SAMple:PERiod? [{MIN MAX},] (@<ch_list>)</p> <p>SOURce:FUNCTion:TRACe:NCYCles {<count> MIN MAX DEF INFinity}, (@<ch_list>)</p> <p>SOURce:FUNCTion:TRACe:NCYCles? [{MIN MAX},] (@<ch_list>)</p> <p>SOURce:FUNCTion:TRACe:SINdEx <point>, (@<ch_list>)</p> <p>SOURce:FUNCTion:TRACe:SINdEx? (@<ch_list>)</p> <p>SOURce:FUNCTion:TRACe[:NAME] <name>, (@<ch_list>)</p> <p>SOURce:FUNCTion:TRACe[:NAME]? (@<ch_list>)</p> <p>SOURce:FUNCTion:TRIGger:IMMediate (@<ch_list>)</p> <p>SOURce:FUNCTion:VOLTagE:GAIN {<gain> MIN MAX DEF}, (@<ch_list>)</p> <p>SOURce:FUNCTion:VOLTagE:GAIN? [{MIN MAX},] (@<ch_list>)</p> <p>SOURce:FUNCTion:VOLTagE:OFFSet {<offset> MIN MAX DEF}, (@<ch_list>)</p> <p>SOURce:FUNCTion:VOLTagE:OFFSet? [{MIN MAX},] (@<ch_list>)</p>	
	<p>SOURce (External Clock Output)</p>	<p>SOURce:MODule:CLock:FREQuency {<frequency> MIN MAX DEF}, 1</p> <p>SOURce:MODule:CLock:FREQuency? [{MIN MAX},] 1</p> <p>SOURce:MODule:CLock:LEVel {<voltage> MIN MAX DEF}, 1</p> <p>SOURce:MODule:CLock:LEVel? [{MIN MAX},] 1</p> <p>SOURce:MODule:CLock:STATe {OFF ON 1}, 1</p> <p>SOURce:MODule:CLock:STATe? 1</p>

Subsystem	Commands
OUTPut (DAC Configuration)	OUTPut[:STATe] {OFF ON 1}, (@<ch_list>) OUTPut[:STATe]? (@<ch_list>)
TRACe (Trace Waveform Configuration)	TRACe:CATalog? {(@<channel>)}1} TRACe:DELeTe:ALL {(@<channel>)}1} TRACe:DELeTe[:NAME] {(@<channel>)}1}, <name> TRACe:FREE? {(@<channel>)}1} TRACe:POINts? {(@<channel>)}1}, <name> TRACe[:DATA] 1, <name>, {<binary_block>}<value>, <value> [, <value>, ...] TRACe[:DATA]:DAC 1, <name>, {<binary_block>}<value>, <value> [, <value>, ...] TRACe[:DATA]:FUNCTion 1, <type>, <name>, <points>
ROUTe (Channel Labeling)	ROUTe:CHANnel:LABel:CLEar:MODule 1 ROUTe:CHANnel:LABel[:DEFine] "<label>", (@<ch_list>) ROUTe:CHANnel:LABel[:DEFine]? [<type>.] (@<ch_list>)
ROUTe (Sequence Operation)	ROUTe:SEQuence:CATalog? ROUTe:SEQuence:DEFine <name>, "<commands>" ROUTe:SEQuence:DEFine? <name> ROUTe:SEQuence:DELeTe:ALL ROUTe:SEQuence:DELeTe[:NAME] <name> ROUTe:SEQuence:DONE? ROUTe:SEQuence:TRIGger[:IMMediate] <name> ROUTe:SEQuence:TRIGger:SOURce <name>, MANual ROUTe:SEQuence:TRIGger:SOURce? <name> ROUTe:SEQuence:WAIT

L4451A Example Program Segments

The programming examples below provide you with SCPI command examples to use for actions specific to the DAC module.

The slot and channel addressing scheme used in these examples follow the form 1ccc where ccc is the three- digit channel number. Valid channels for this module are 001- 004. For information on specific configurations, refer to the simplified schematic on [page 279](#).

For detailed example programs involving multiple drivers and development environments, refer to the example programs for the L4400 Series on www.keysight.com/find/L4400.

Level Mode

Example: Outputting a DC voltage level This command sets the output voltage level for the specified DAC channels. After setting the desired level, send the `OUTPut:STATe` command to close the corresponding output relay and enable outputs from the specified channels. The following command outputs +2.5 V DC on DAC channels 1 and 2.

```
SOURce:VOLTage 2.5, (@1001,1002)
OUTPut:STATe ON, (@1001,1002)
```

Example: Outputting a current level This command sets the output current level on the specified channels on the DAC module. After setting the desired level, send the `OUTPut:STATe` command to close the corresponding output relay and enable outputs from the specified channels. The following command outputs +5 mA on DAC channels 1 and 2 and closes the output relay.

```
SOURce:CURRent 5E-3, (@1001,1002)
OUTPut:STATe ON, (@1001,1002)
```

Waveform Mode

Example: Downloading a waveform to memory and outputting waveform from DACs The following command segment downloads a 1000- point sine waveform to memory and outputs the waveform from DAC channels 1 and 2. The trace name is `TEST_SINE`.

```
TRACe:FUNCTion 1,SINusoid, TEST_SINE, 1000
```

```
SOURce:FUNction:TRACe TEST_SINE,(@1001,1002)
OUTPut:STATe ON,(@1001,1002)
SOURce:FUNction:ENABle ON,(@1001,1002)
```

Example: Downloading trace points to memory and outputting waveform from DACs The following command segment downloads seven trace points to memory and output the waveform from DAC channels 1 and 2. The trace name is NEG_RAMP.

```
TRACe:DATA 1,NEG_RAMP, 1, .67, .33, 0, -.33, -.67, -1
SOURce:FUNction:TRACe NEG_RAMP,(@1001,1002)
OUTPut:STATe ON,(@1001,1002)
SOURce:FUNction:ENABle ON,(@1001,1002)
```

Example: Setting the amplitude of a waveform for offset and gain The following commands set the offset to 5.25 and the gain to 1.5 on DAC channels 1 and 2.

```
SOURce:FUNction:VOLTage:OFFSet 5.25,(@1001,1002)
SOURce:FUNction:VOLTage:GAIN 1.5,(@1001,1002)
```

Example: Setting cycle count for a waveform The following command segments turn off the trace output mode on DAC channels 1 and 2, set the cycle count to 100, then turn the trace output mode back on.

```
SOURce:FUNction:ENABle OFF,(@1001,1002)
SOURce:FUNction:TRACe:NCYCles 100,(@1001,1002)
SOURce:FUNction:ENABle ON,(@1001,1002)
```

Example: Deleting a waveform The following command deletes the trace named TEST_WFORM from the instrument.

```
TRACe:DELeTe 1,TEST_WFORM
```

External Clock

Example: Selecting an external clock source and setting a clock divisor

The first command selects the external clock source on DAC channels 1 and 2. The external clock input is shared between these two channels. The second

command sets the clock divisor to 100 on the same DAC channels (the external clock input signal is divided by 100).

```
SOURce:FUNction:CLOCK:SOURce EXTernal, (@1001,1002)
```

```
SOURce:FUNction:CLOCK:EXTernal:DIVisor 100, (@1001,1002)
```

Example: Outputting a clock The following commands set the clock output frequency to 5 kHz and enable the output.

```
SOURce:MODule:CLOCK:FREQuency 5E+3,1
```

```
SOURce:MODule:CLOCK:STATE ON,1
```

External Trigger

Example: Selecting the external trigger source and issuing trigger source

The following command segment enables the trigger output mode and then enables the external trigger source on DAC channels 1 and 2. The last command issues an external trigger pulse from the module.

```
SOURce:MODule:TRIGger:OUTPut ON,1
```

```
SOURce:FUNction:TRIGger:SOURce EXTernal, (@1001,1002)
```

```
SOURce:MODule:TRIGger:EXTernal:IMMediate 1
```

Configuring a DAC Module

Example: Querying the system for module identify (all modules) The following command returns the identity of the L4451A instrument.

```
SYSTem:CTYPE? 1
```

Example: Resetting the module(s) to power-on state The following command resets the instrument.

```
SYST:CPON 1
```

NOTE

Using this command will erase any downloaded waveforms.

L4451A Simplified Block Diagrams

The following diagram shows how the module is generally configured.

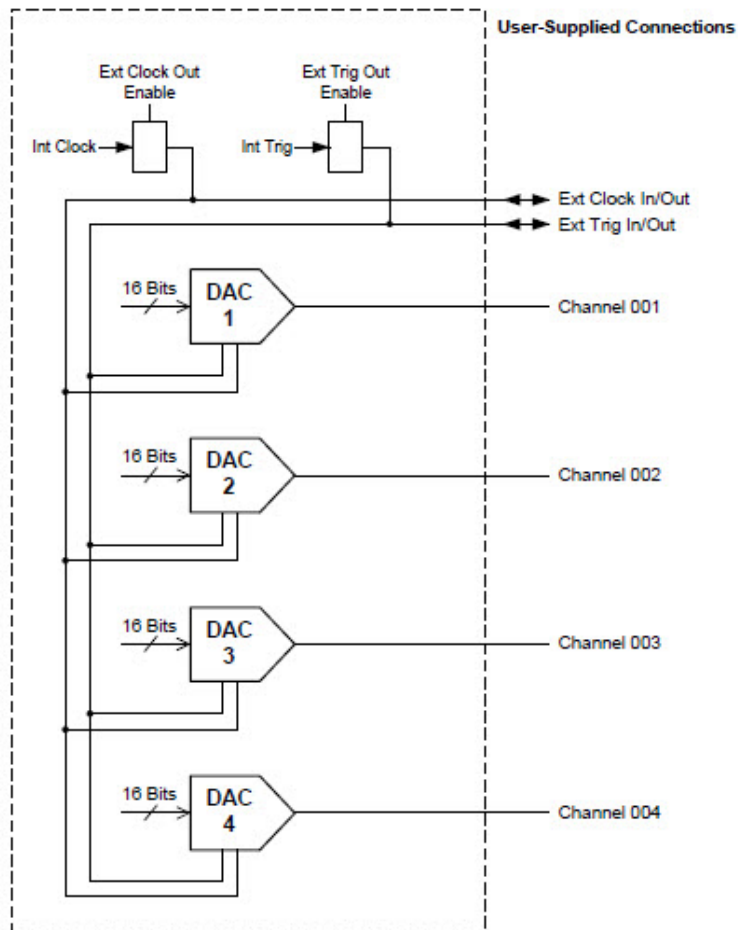

For more detail on the internal configuration of each DAC channel, see the next page.

The following diagram shows individual DAC channel configuration. All channels are configured the same.

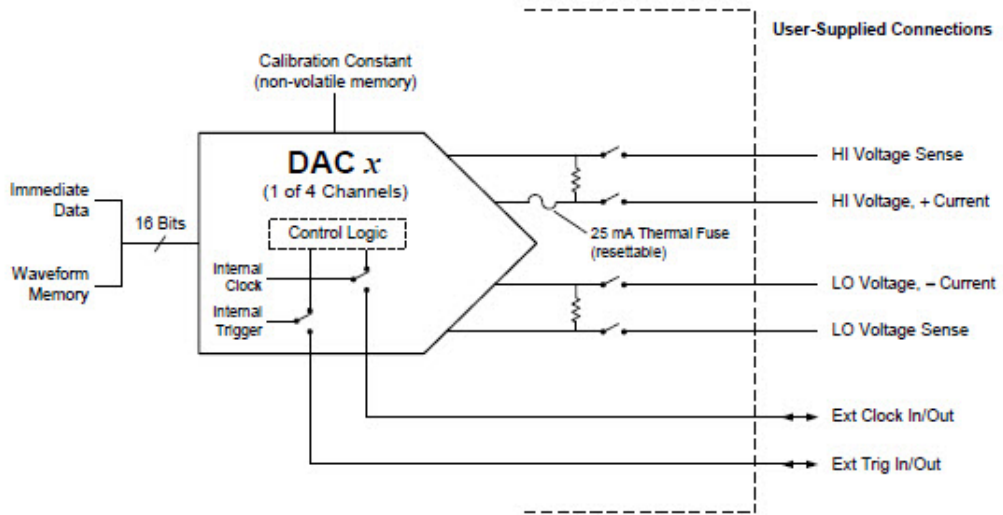

L4451A D-Sub Connector Pinout

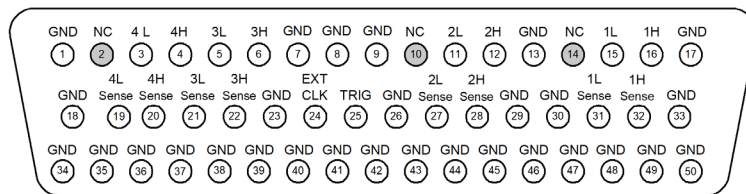

50-Pin D-Sub Female Connector

Description	Socket	Description	Socket	Description	Socket	Description	Socket	Description	Socket
1L	15	3L Sense	21	GND	8	GND	34	GND	44
1H	16	3H Sense	22	GND	9	GND	35	GND	45
1L Sense	31	4L	3	GND	13	GND	36	GND	46
1H Sense	32	4H	4	GND	17	GND	37	GND	47
2L	11	4L Sense	19	GND	18	GND	38	GND	48
2H	12	4H Sense	20	GND	23	GND	39	GND	49
2L Sense	27	External Clock	24	GND	26	GND	40	GND	50
2H Sense	28	Trigger	25	GND	29	GND	41	No Connect	2
3L	5	GND	1	GND	30	GND	42	No Connect	10
3H	6	GND	7	GND	33	GND	43	No Connect	14

34951T Terminal Block

Each terminal block is labeled with the model number and the abbreviated instrument name.

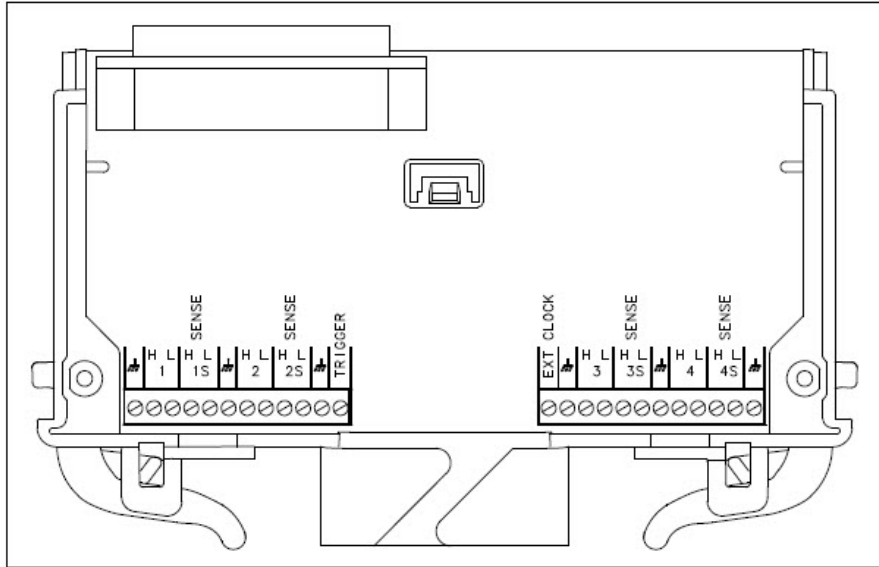

Figure 9-1 L4451A Terminal Block.

THIS PAGE HAS BEEN INTENTIONALLY LEFT BLANK.

10 L4452A Multifunction Module with DIO, D/A, and Totalizer

L4452A Multifunction Module	284
L4452A SCPI Command Summary	285
L4452A Example Program Segments	290
L4452A Simplified Block Diagram	292
L4452A D-Sub Connector	293
34952T Terminal Block	293

L4452A Multifunction Module

The L4452A Multifunction Module with DIO, D/A, and Totalizer combines four 8-bit ports of digital input/output, a 100 kHz totalizer, and two ± 12 volt earth-referenced analog outputs. You can include digital inputs and totalizer input in a scan list. You can make connections via standard 50-pin D-sub cables or the optional 34952T terminal block.

Digital Input/Output

The Digital Input/Output (DIO) consists of four 8-bit ports with TTL-compatible inputs and output. The open-drain outputs can sink up to 400 mA. You can configure the DIO ports for 8, 16, or 32-bit operations. The DIO channels are connected by internal 5 V pull-up resistors when configured as inputs.

Totalizer Input

The 32-bit totalizer can count pulses up to 100 kHz. You can configure the totalizer to count on the rising edge or falling edge of the input signal. A TTL high signal applied to the Gate terminal enables counting and a low signal disables counting. A TTL low signal applied to the Not-Gate terminal enables counting and a high signal disables counting. The totalizer counts only when both terminals are enabled.

NOTE

When the gate is not connected, the gate terminal is pulled to the enabled state, effectively creating a “gate always” condition.

Analog Output (DAC)

The two analog outputs are capable of outputting voltages between ± 12 volts with 16 bits of resolution. Each DAC channel is capable of driving/sinking 10 mA maximum current. You can use the two analog outputs to source bias voltages to your DUT, to control your analog programmable power supplies, or as set points for your control systems.

L4452A SCPI Command Summary

Table 10-1 lists the instrument-specific SCPI commands that apply to the L4452A Multifunction Module instrument. Table 3-3 (Chapter 3) lists the SCPI commands that apply to all L4400 series instruments.

For complete information on all SCPI commands, refer to the Programmer's Reference at www.keysight.com/find/L4400.

Table 10-1 L4452A SCPI Command Summary.

Subsystem	Commands
CONFigure (Digital I/O)	CONFigure:DIgital {BYTE 1 WORD 2 LWORD 4}, [<voltage>, [{NORMal INVerted},] (@<ch_list>) CONFigure:DIgital:DIRection {INPut 0 OUTPut 1}, (@<ch_list>) CONFigure:DIgital:DIRection? (@<ch_list>) CONFigure:DIgital:WIDTh {BYTE 1 WORD 2 LWORD 4}, (@<ch_list>) CONFigure:DIgital:WIDTh? (@<ch_list>)
MEASure (Digital I/O)	MEASure:DIgital? {BYTE 1 WORD 2 LWORD 4}, [<voltage>, [{NORMal INVerted},] (@<ch_list>)
SENSe (Digital I/O)	[SENSe:]DIgital:DATA[:{BYTE 1 WORD 2 LWORD 4}]? [{DECimal BINary HEXadecimal OCTal},] (@<ch_list>) [SENSe:]DIgital:DATA:BIT? <bit>, (@<ch_list>)
SENSe (Totalizer)	[SENSe:]TOTAlize:CLEar:IMMediate (@<ch_list>) [SENSe:]TOTAlize:DATA? (@<ch_list>) [SENSe:]TOTAlize:SLOPe {NEGative POSitive}, (@<ch_list>) [SENSe:]TOTAlize:SLOPe? (@<ch_list>) [SENSe:]TOTAlize:THReshold[:MODE] {AC TTL}, (@<ch_list>) [SENSe:]TOTAlize:THReshold[:MODE]? (@<ch_list>) [SENSe:]TOTAlize:TYPE {READ RRESet}, (@<ch_list>) [SENSe:]TOTAlize:TYPE? (@<ch_list>)
SENSe (Digital Pattern Compare)	[SENSe:]DIgital:MEMory:COMPare:ACtion {CONTInue START STOP}, (@<ch_list>) [SENSe:]DIgital:MEMory:COMPare:ACtion? (@<ch_list>)

Subsystem	Commands
SOURce (Digital I/O)	SOURce:DIGital:DATA[:{BYTE 1 WORD 2 LWORD 4}] <data>, (@<ch_list>) SOURce:DIGital:DATA[:{BYTE 1 WORD 2 LWORD 4}]? [[DECimal BINary HEXadecimal OCTal],] (@<ch_list>) SOURce:DIGital:DATA:BIT {0 1}, <bit>, (@<ch_list>) SOURce:DIGital:DATA:BIT? <bit>, (@<ch_list>)
SOURce (DAC)	SOURce:VOLTage[:LEVel] {<voltage> MIN MAX DEF}, (@<ch_list>) SOURce:VOLTage[:LEVel]? [{MIN MAX},] (@<ch_list>)
CALCulate (Digital Pattern Compare)	CALCulate:COMParE:DATA[:{BYTE 1 WORD 2 LWORD 4}] <data>, (@<ch_list>) CALCulate:COMParE:DATA? (@<ch_list>) CALCulate:COMParE:MASK[:{BYTE 1 WORD 2 LWORD 4}] <data>, (@<ch_list>) CALCulate:COMParE:MASK? (@<ch_list>) CALCulate:COMParE:STATe {OFF 0 ON 1}, (@<ch_list>) CALCulate:COMParE:STATe? (@<ch_list>) CALCulate:COMParE:TYPE {EQUal NEQal}, (@<ch_list>) CALCulate:COMParE:TYPE? (@<ch_list>)
CALCulate (Alarm Limit)	CALCulate:LIMit:LOWer {<value> MIN MAX DEF}, (@<ch_list>) CALCulate:LIMit:LOWer? [{MIN MAX},] (@<ch_list>) CALCulate:LIMit:LOWer:STATe {OFF 0 ON 1}, (@<ch_list>) CALCulate:LIMit:LOWer:STATe? (@<ch_list>) CALCulate:LIMit:UPPer {<value> MIN MAX DEF}, (@<ch_list>) CALCulate:LIMit:UPPer? [{MIN MAX},] (@<ch_list>) CALCulate:LIMit:UPPer:STATe {OFF 0 ON 1}, (@<ch_list>) CALCulate:LIMit:UPPer:STATe? (@<ch_list>)
CALCulate (Measurement Statistics)	CALCulate:AVERage:AVERage? [(@<ch_list>)] CALCulate:AVERage:CLear [(@<ch_list>)] CALCulate:AVERage:COUNT? [(@<ch_list>)] CALCulate:AVERage:MAXimum? [(@<ch_list>)] CALCulate:AVERage:MAXimum:TIME? [(@<ch_list>)] CALCulate:AVERage:MINimum? [(@<ch_list>)] CALCulate:AVERage:MINimum:TIME? [(@<ch_list>)] CALCulate:AVERage:PTPeak? [(@<ch_list>)]

Subsystem	Commands
ROUTE (Monitor)	ROUTe:MONitor:DATA? ROUTe:MONitor:MODE {CHANnel DMM} ROUTe:MONitor:MODE? ROUTe:MONitor:STATe {OFF ON 1} ROUTe:MONitor:STATe? ROUTe:MONitor[:CHANnel] (@<channel>) ROUTe:MONitor[:CHANnel]? ROUTe:MONitor[:CHANnel]:ENABle {OFF ON 1}, (@<ch_list>) ROUTe:MONitor[:CHANnel]:ENABle? (@<ch_list>)
ROUTE (Scanning)	ROUTe:CHANnel:DELay {<seconds> MIN MAX DEF}, (@<ch_list>) ROUTe:CHANnel:DELay? [{MIN MAX},] (@<ch_list>) ROUTe:CHANnel:DELay:AUTO {OFF ON 1}, (@<ch_list>) ROUTe:CHANnel:DELay:AUTO? (@<ch_list>) ROUTe:SCAN (@<scan_list>) ROUTe:SCAN? ROUTe:SCAN:ADD (@<ch_list>) ROUTe:SCAN:REMOve (@<ch_list>) ROUTe:SCAN:ORDered {OFF ON 1} ROUTe:SCAN:ORDered? ROUTe:SCAN:SIZE?
ROUTE (Channel Labeling)	ROUTe:CHANnel:LABel:CLEar:MODule 1 ROUTe:CHANnel:LABel[:DEFine] "<label>", (@<ch_list>) ROUTe:CHANnel:LABel[:DEFine]? [{USER FACTory},] (@<ch_list>)
ROUTE (Sequence Operation)	ROUTe:SEQuence:CATalog? ROUTe:SEQuence:DEFine <name>, "<commands>" ROUTe:SEQuence:DEFine? <name> ROUTe:SEQuence:DELeTe:ALL ROUTe:SEQuence:DELeTe[:NAME] <name> ROUTe:SEQuence:DONE? ROUTe:SEQuence:TRIGger[:IMMediate] <name> ROUTe:SEQuence:TRIGger:SOURce <name>, {ALARm1 ALARm2 MANual} ROUTe:SEQuence:TRIGger:SOURce? <name> ROUTe:SEQuence:WAIT

Subsystem	Commands
FORMat (Scanning)	FORMat:BORDer {NORMal SWAPped} FORMat:BORDer? FORMat:READing:ALARm {OFF 0 ON 1} FORMat:READing:ALARm? FORMat:READing:CHANnel {OFF 0 ON 1} FORMat:READing:CHANnel? FORMat:READing:TIME {OFF 0 ON 1} FORMat:READing:TIME? FORMat:READing:TIME:TYPE {ABSolute RELative} FORMat:READing:TIME:TYPE? FORMat:READing:UNIT {OFF 0 ON 1} FORMat:READing:UNIT?
General Scanning	ABORT INITitate READ? [(@<ch_list>)]
SWEep (Scanning)	SWEep:COUNT {<count> MIN MAX DEF} SWEep:COUNT? [{MIN MAX}]
TRIGger (Scanning)	TRIGger:COUNT {<count> MIN MAX DEF INFinity} TRIGger:COUNT? [{MIN MAX}] TRIGger:SOURce {IMMediate BUS EXTernal ALARm1 ALARm2 TImer} TRIGger:SOURce? TRIGger:TImer {<seconds> MIN MAX DEF} TRIGger:TImer? [{MIN MAX}]

Subsystem	Commands
TRIGger (General)	*TRG
	TRIGger:COUnT {<count> MIN MAX DEF INFinity}
	TRIGger:COUnT? [{MIN MAX}]
	TRIGger:DELAy {<seconds> MIN MAX}
	TRIGger:DELAy? [{MIN MAX}]
	TRIGger:DELAy:AUTO {OFF 0 ON 1}
	TRIGger:DELAy:AUTO?
	TRIGger:SOURce {IMMediate BUS EXTErnal TImEr}
	TRIGger:SOURce?
	TRIGger:SOURce:ALARm[:MODE] {SINGle CONTInuous}
	TRIGger:SOURce:ALARm[:MODE]?
	TRIGger:TImEr {<seconds> MIN MAX DEF}
TRIGger:TImEr? [{MIN MAX}]	
OUTput (Alarm Limit)	OUTPut:ALARm{1 2}:CLEAr
	OUTPut:ALARm:CLEAr:ALL
	OUTPut:ALARm:MODE {LATCH TRACK}
	OUTPut:ALARm:MODE?
	OUTPut:ALARm{1 2}:SEQuence?
	OUTPut:ALARm:SLOPe {NEGAtive POSitive}
	OUTPut:ALARm:SLOPe?
	OUTPut:ALARm{1 2}:SOURce (@<ch_list>)
OUTPut:ALARm{1 2}:SOURce?	
DATA (Reading Memory)	DATA:POINts:EVENT:THReshold <num_readings>
	DATA:POINts:EVENT:THReshold?
	DATA:POINts?
	DATA:REMOve? <num_readings>
	FETCh?
	R? [<max_count>]
SYSTem:TIME:SCAN?	
DATA (Measurement Statics)	DATA:LAST? [, @<channel>]

L4452A Example Program Segments

The following sections contain example program segments of commonly used instrument functions.

The slot and channel addressing scheme used in these examples follow the form 1ccc where ccc is the channel number. For information on specific configurations, refer to the simplified schematic on [page 292](#).

For detailed example programs involving multiple drivers and development environments, refer to the example programs for the L4400 Series on www.keysight.com/find/L4400.

Digital Input/Output

Example: Configuring a DIO channel The following program segment configures channel 1 on the DAC as an output and then reads the output value (the channel is not reconfigured as an input). Then, the channel is reconfigured as an input and the value is read again.

The second command below returns 64 as it is physically reading the output data.

```
SOURce:DIGital:DATA:BYTE 64,(@1001)
```

```
SENSe:DIGital:DATA:BIT? 0,(@1001)
```

The second command below returns whatever is being input externally.

```
CONFigure:DIGital:STATE INPut,(@1001)
```

```
SENSe:DIGital:DATA:BIT? 0,(@1001)
```

Totalizer

Example: Reading totalizer channel count The following command reads the count on totalizer channel 5.

```
SENSe:TOTalize:DATA? (@1005)
```

Example: Configuring the totalizer reset mode To configure the totalizer reset mode, send either of the following commands.

The following command configures totalizer channel 5 to be read without resetting its count.

```
SENSe:TOTalize:TYPE READ,(@1005)
```

The following command configures totalizer channel 5 to be reset to "0" after it is read (RRESet means "read and reset").

```
CONFigure:TOTalize RRES,(@1005)
```

Example: Configuring the totalizer for count This command configures the totalizer to count on the rising edge or falling edge of the input signal. The following command configures the totalizer (channel 5) to count on the negative edge (falling) of the input signal.

```
TOTalize:SLOPe NEGative,(@1005)
```

Example: Clearing count on the totalizer channel This command immediately clears the count on the specified totalizer channel (channel 5).

```
TOTalize:CLEAR:IMMediate (@1005)
```

DAC Output

Example: Setting output voltage This command sets the output voltage level for the specified DAC channels. The following command outputs +2.5 V DC on DAC channels 6 and 7.

```
SOURce:VOLTage 2.5,(@1006,1007)
```

Querying and Resetting the L4452A

Example: Querying the instrument identify The following command returns the identify of the multifunction module.

```
SYSTem:CTYPe? 1
```

Example: Resetting the instrument to its power-on state The following command resets the multifunction module to its power-on state.

```
SYSTem:CPON 1
```

L4452A Simplified Block Diagram

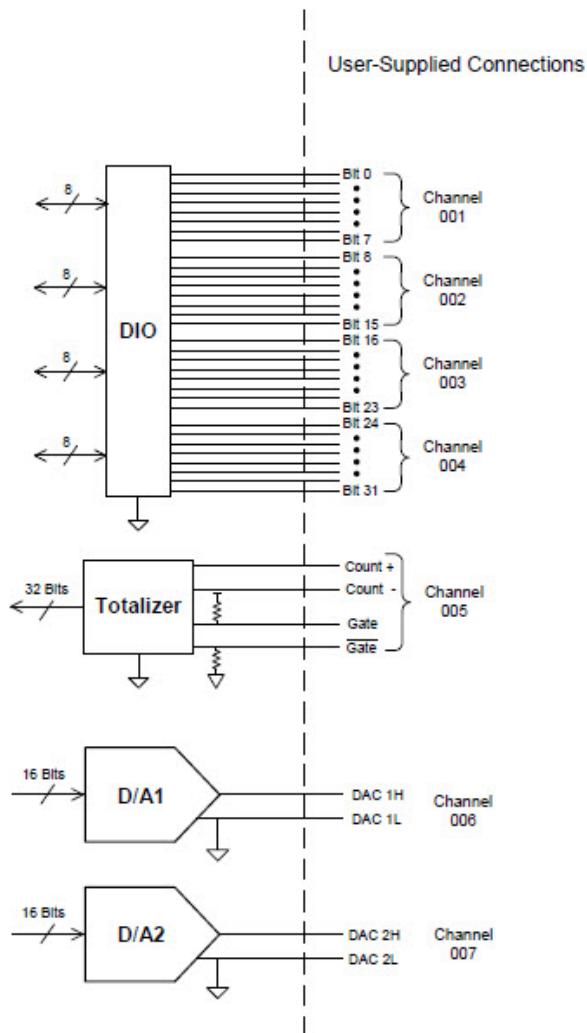

L4452A D-Sub Connector

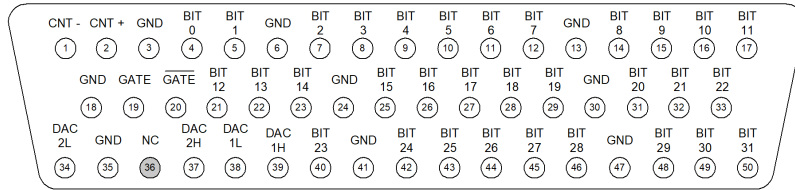

50-Pin D-Sub Female Connector

Description	Socket	Description	Socket	Description	Socket	Description	Socket			
Channel 1	Bit 0	4	Channel 3	Bit 16	26	Channel 5 Totalizer	Count -	1	GND	47
	Bit 1	5		Bit 17	27		Count +	2	No Connect	36
	Bit 2	7		Bit 18	28		Gate	19		
	Bit 3	8		Bit 19	29		Not-Gate	20		
	Bit 4	9		Bit 20	31	Channel 6	DAC 1L	38		
	Bit 5	10		Bit 21	32		DAC 1H	39		
	Bit 6	11		Bit 22	33		Channel 7	DAC 2L	34	
	Bit 7	12		Bit 23	40	DAC 2H		37		
Channel 2	Bit 8	14	Channel 4	Bit 24	42		GND	3		
	Bit 9	15		Bit 25	43		GND	6		
	Bit 10	16		Bit 26	44		GND	13		
	Bit 11	17		Bit 27	45		GND	18		
	Bit 12	21		Bit 28	46		GND	24		
	Bit 13	22		Bit 29	48		GND	30		
	Bit 14	23		Bit 30	49		GND	35		
	Bit 15	25		Bit 31	50		GND	41		

34952T Terminal Block

Each terminal block is labeled with the model number and the abbreviated module name.

The 34952T provides space for breadboard and for a connector to control an external Opto- 22 standard board.

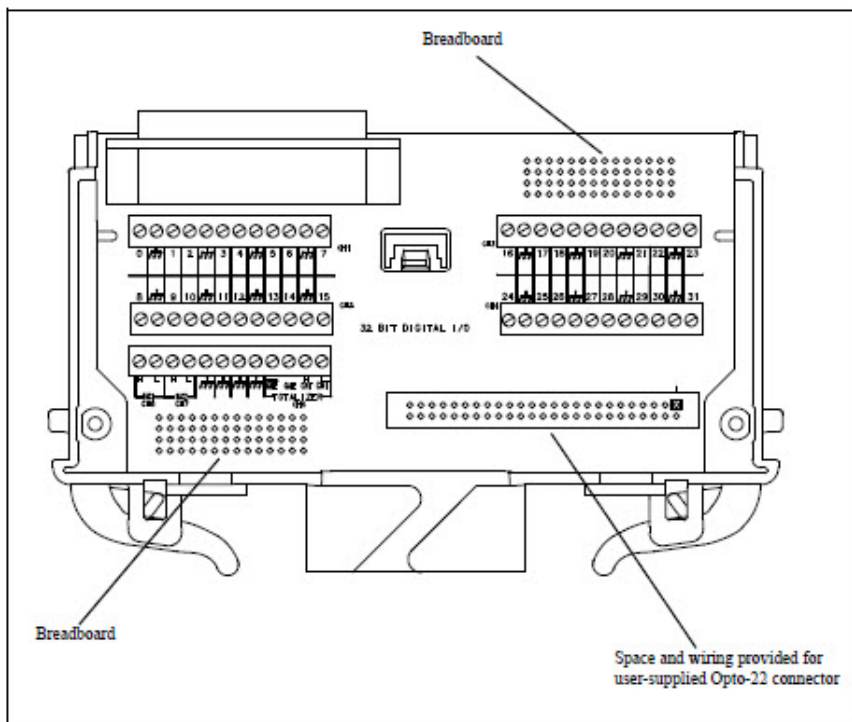

Figure 10-1 L4452A Terminal Block.

11 Appendix A

L4451A and L4452A Calibration Procedures

Calibration Procedures	296
Keysight Technologies Calibration Services	296
Calibration Interval	296
Time Required for Calibration	297
Automating Calibration Procedures	297
Recommended Test Equipment	297
Calibration Security	298
Calibration Message	299
Calibration Count	299
Calibration Process	300
Aborting a Calibration in Progress	300
Performance Verification Tests	301
L4451A and L4452A Performance Test Considerations	301
L4451A 4-Channel Isolated DAC Module	301
L4452A Multifunction Module	309

Calibration Procedures

This section contains performance verification and adjustment (calibration) procedures for the L4400 Series L4451A 4- Channel Isolated D/A Converter and L4452A Multifunction Module.

Closed-Case Electronic Calibration These instruments feature closed- case electronic calibration. No internal mechanical adjustments are required. The instruments calculate correction factors based upon the readings from a separate DMM sent to the instruments during the calibration procedure. The new correction factors are stored in non- volatile memory until the next calibration adjustment is performed. Non-volatile EEPROM calibration memory does not change when power has been off or after a remote interface reset.

Keysight Technologies Calibration Services

When your instruments are due for calibration, contact your local Keysight Service Center for low- cost recalibration. The L4451A and L4452A are supported on automated calibration systems which allow Keysight to provide this service at competitive prices.

Calibration Interval

The instruments should be calibrated on a regular interval determined by the accuracy requirements of your application.

A 1- year interval is adequate for most applications. Accuracy specifications are warranted only if adjustment is made at regular calibration intervals. Accuracy specifications are not warranted beyond the 1- year calibration interval. Keysight does not recommend extending calibration intervals beyond 2 years for any application.

Adjustment is Recommended

Specifications are only guaranteed within the period stated from the last adjustment. Whatever calibration interval you select, Keysight recommends that complete re- adjustment should always be performed at the calibration interval. This will assure that the L4451A and L4452A will remain within specification for the next calibration interval. This criteria for re- adjustment provides the best long- term stability.

Performance data measured during Performance Verification Tests does not guarantee the instruments will remain within these limits unless the adjustments are performed.

Use the Calibration Count feature (see [page 299](#)) to verify that all adjustments have been performed.

Time Required for Calibration

The L4451A and L4452A can be automatically calibrated under computer control. With computer control you can perform the complete calibration procedures and performance verification tests in less than 30 minutes once the instruments are warmed- up (see [L4451A and L4452A Performance Test Considerations](#)).

Automating Calibration Procedures

You can automate the complete verification and adjustment procedures outlined in this chapter. You can program the instrument configurations specified for each test and then enter readback verification data into a test program and compare the results to the appropriate test limit values.

The instruments must be unsecured prior to initiating the calibration procedures (see [Calibration Security](#)).

Recommended Test Equipment

The test equipment recommended for the performance verification and adjustment procedures is listed in [Table 11-1](#). If the exact instrument is not available, substitute calibration standards of equivalent accuracy.

Table 11-1 Recommended Test Equipment.

Application	Recommended Equipment	Accuracy Requirements
Analog Output L4451A	Keysight 34401A, 34410A, or 34411A	<1/5 L4451A 24-hour voltage / current specification
Analog Output L4452A	Keysight 34401A, 34410A, or 34411A	<1/5 L4452A 24-hour voltage / current specification

Calibration Security

This feature allows you to enter a security code to prevent accidental or unauthorized adjustments of the instruments. When you first receive your instrument, it is secured. Before you can adjust the instrument, you must unsecure it by entering the correct security code.

NOTE

If you forget your security code, you can disable the security feature by following the procedure below.

- Calibration is secured and unsecured using the command:
`CALibration:SECure:STATe <mode>,<code>`
- The security code is set to ATL4400 when the instrument is shipped from the factory. The security code is stored in non-volatile memory, and does not change when power has been off, after a Factory Reset (`*RST` command), or after an Instrument Preset (`SYSTem:PRESet` command).
- The security code may contain up to 12 alphanumeric characters. The first character must be a letter, but the remaining characters can be letters, numbers, or an underscore (`_`). You do not have to use all 12 characters but the first character must always be a letter.
- The L4451A 4-Channel DAC has two modes of adjustment, based upon the setting of the calibration security feature. Additional details are described in “[L4451A 4-Channel Isolated DAC Module](#)” on page 301.

Refer to the Programmer's Reference Help File located at www.keysight.com/find/L4400 for complete information on the L4451A and L4452A calibration command.

To Unsecure the Instrument Without the Security Code To unsecure the instrument and reset the security code when the current security code is unknown, follow the steps below.

- 1 Turn off power to the instrument.
- 2 Remove the instrument sub-assembly from the instrument carrier.
- 3 Turn on the instrument (carrier).

- 4 Send the command `CALibration:SECure:STATE OFF,<code>` to the instrument. Enter ANY valid (see above) code. This code is temporarily used to unsecure the instrument.
- 5 Send the command `CALibration:SECure:CODE <new_code>` and enter the instrument's new security code. Record this code for future reference.
- 6 Send the command `CALibration:SECure:STATE ON` to activate the new code and secure the instrument.
- 7 Turn off the instrument and re- install the instrument sub- assembly into the instrument carrier. Turn on the instrument.

Continue with the procedures for calibrating the instrument. Note that the instrument will first have to be unsecured using the new security code set in Step 5.

Calibration Message

The instruments allow you to store a message in calibration memory. For example, you can store such information as the date when the last calibration was performed, the date when the next calibration is due, the instrument's serial number, or even the name and phone number of the person to contact for a new calibration.

- You can record a calibration message only when the instrument is unsecured. You can read the calibration message whether the instrument is secured or unsecured.
- The calibration message may contain up to 40 characters.
- Calibration Message Commands:

```
CALibration:STRing "<string>"
```

```
CALibration:STRing?
```

Calibration Count

You can query the L4451A and L4452A to determine how many calibrations have been performed. Note that your instrument was calibrated before it left the factory. When you receive your instrument, be sure to read the count to determine its initial value.

- The calibration count increments up to a maximum of $2^{32} - 1$ after which it rolls over to “0”. Since the value increments by one for each calibration point, a complete calibration may increase the value by many counts.
- Calibration Count Command:
`CALibration:COUNT?`

Calibration Process

The following general procedure is the recommended method to complete a full instrument calibration.

- 1 See [L4451A and L4452A Performance Test Considerations](#)
- 2 Perform the verification tests to characterize the instrument (incoming data).
- 3 Unsecure the instrument for calibration (“[Calibration Security](#)” on page 298).
- 4 Perform the DAC adjustment procedures on either the L4451A or L4452A.
- 5 Secure the instrument against unauthorized calibration.
- 6 Note the security code and calibration count in the instrument’s maintenance records.

Aborting a Calibration in Progress

Sometimes it may be necessary to abort a calibration after the procedure has been initiated. You can abort a calibration at any time by turning off the power. You can also abort the calibration by sending the device clear message or the `CALibration:ABORt` command.

CAUTION

If you abort a calibration in progress by cycling power when the instrument is attempting to write new calibration constants to EEPROM, you may lose all calibration constants for the function. Typically, upon re-applying power, the instrument will report error 705 Cal:Aborted. You may also generate errors 740 through 746. If this occurs, you should not use the instrument until a complete re-adjustment has been performed.

Performance Verification Tests

Use the Performance verification tests to verify the performance of the instruments. The performance verification tests use the instrument's specifications contained in the L4451A and L4452A Product Data Sheets.

L4451A and L4452A Performance Test Considerations

For optimum performance, all test procedures should comply with the following recommendations:

- Assure that the calibration ambient temperature is stable and between 18 °C and 28 °C. Ideally the calibration should be performed at $23\text{ °C} \pm 1\text{ °C}$.
- Assure ambient relative humidity is less than 80%.
- Install the plug-in module and allow a 1 hour warm-up period before verification or adjustment.
- Use shielded twisted pair PTFE insulated cables to reduce settling and noise errors. Keep the input cables as short as possible.
- Remove all user wiring and connections from the instruments before verification or adjustment.

L4451A 4-Channel Isolated DAC Module

Each isolated DAC output channel can be measured and adjusted using a DMM with voltage and current measurement capability.

There are two ways to adjust the DACs, depending upon the state of calibration security:

- If the instrument is secured for calibration when the adjustment is begun, the adjustments are considered volatile. All adjustments are discarded when power is cycled. This provides an easy means to make immediate temperature-compensated adjustments to the DAC outputs without overwriting stored calibration constants.

When this type of adjustment is made, the calibration count (see [page 299](#)) is not advanced.

- If the instrument is unsecured for calibration, the adjustments are written to non-volatile calibration memory. The calibration count (see [page 299](#)) is advanced.

L4451A Verification

The test connections for verifying the L4451A DAC output current and voltage using an external DMM are shown in [Figure 11-1](#) and [Figure 11-2](#).

Note that connections are shown for a single channel.

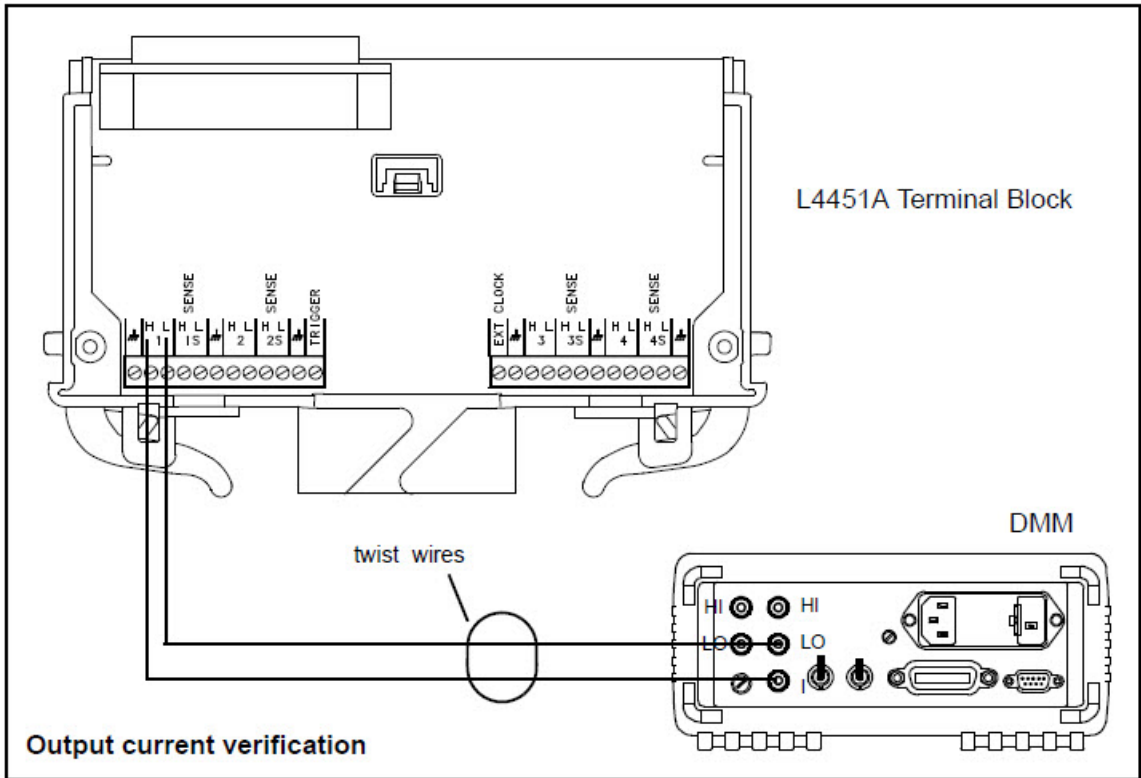

Figure 11-1 L4451A Output Current Connections.

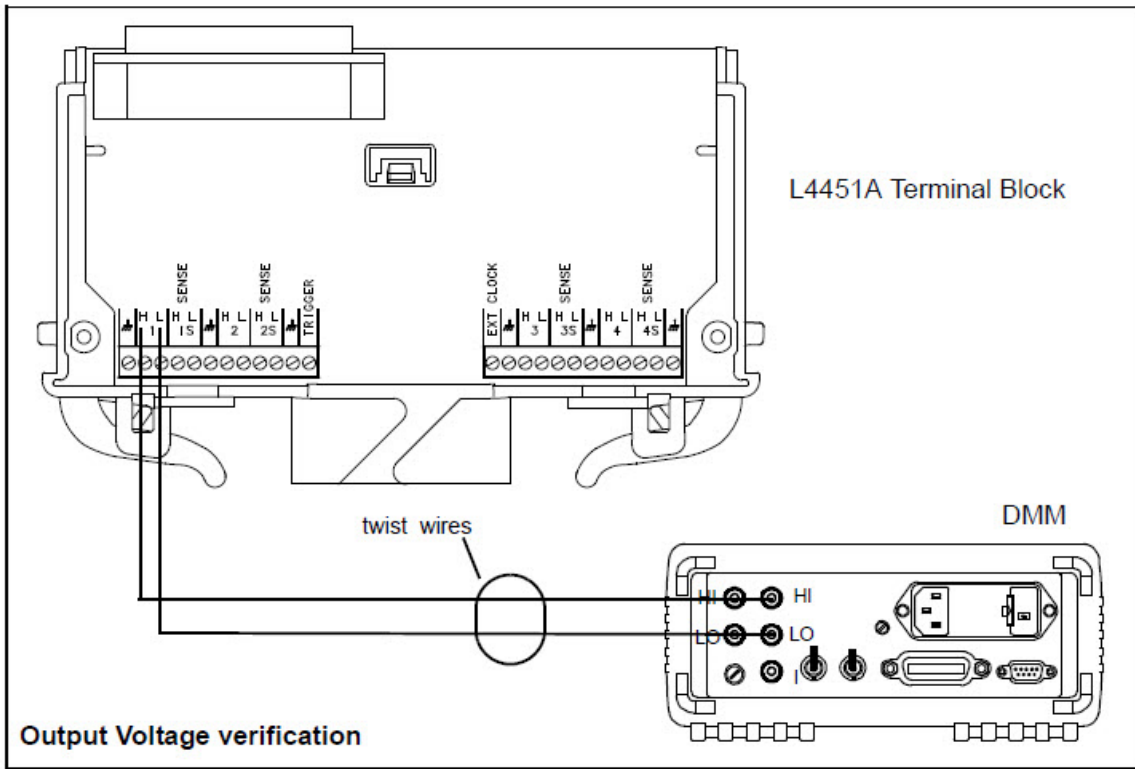

Figure 11-2 L4451A Output Voltage Connections.

Analog Output Verification Test

This procedure is used to check the calibration of the current and voltage outputs on the L4451A 4- channel DAC. Verification checks are performed only for those output values with unique calibration constants.

Current Output Verification

- 1 With the DMM disconnected from the L4451A, set the DMM to the 100mA range or the lowest range that can measure 20 mA (do not use autorange).

- 2 The DMM reading is the current offset for the selected range. If the DMM has “null” capability, turn it on at this time. Otherwise, record the offset which will be subtracted from the subsequent current measurements.
- 3 Connect channel 1 of the L4451A as shown in [Figure 11-1](#). Configure the L4451A to output the currents listed in [Table 11-2](#). For each current level measured, subtract the current offset recorded in Step 2 as applicable. The results should be within the limits listed in [Table 11-2](#).
- 4 Repeat Step 3 for L4451A channels 2, 3, and 4.

Voltage Output Verification

- 1 With the DMM disconnected from the L4451A, set the DMM to the 100V range or the lowest range that can measure 16V (do not use autorange).
- 2 Short the inputs to the DMM. The DMM reading is the offset voltage for the selected range. If the DMM has “null” capability, turn it on at this time. Otherwise, record the offset which will be subtracted from the subsequent voltage measurements.
- 3 Connect channel 1 of the L4451A as shown in [Figure 11-2](#). Configure the L4451A to output the voltages listed in [Table 11-2](#). For each voltage level measured, subtract the offset voltage recorded in Step 2 as applicable. The results should be within the limits listed in [Table 11-2](#).
- 4 Repeat Step 3 for L4451A channels 2, 3, and 4.

NOTE

It is not necessary to test the voltage output at the full rated 10 mA load. If you test the output using a load, connect the sense terminals.

Table 11-2 L4451A Output Current and Voltage Levels.

Output Current	Error From Nominal (90 day)
20 mA	± 23 μ A
15 mA	± 18.5 μ A
10 mA	± 14 μ A
5 mA	± 9.5 μ A

Output Current	Error From Nominal (90 day)
0 mA ^[1]	± 5 µA
-5 mA	± 9.5 µA
-10 mA	± 14 µA
-15 mA	± 18.5 µA
-20 mA	± 23 µA
[1] Apply a measured "0" offset to this measurement	
16 V	± 11 mV
12 V	± 9 mV
10 V	± 8 mV
8 V	± 7 mV
4 V	± 5 mV
0 V	± 3 mV
-4 V	± 5 mV
-8 V	± 7 mV
-10 V	± 8 mV
-12 V	± 9 mV
-16 V	± 11 mV

Analog Output Adjustments

The following analog output adjustment procedures are to be performed following a 1 hour warm up period.

This procedure results in the L4451A setting a zero adjustment and a gain adjustment constant for each DAC output. You must perform all the adjustments on one analog output channel before adjusting the other analog output channels. The procedure can be aborted at any time using the command:

`CALibration:ABORt`

Each of the four DAC channels is calibrated separately for voltage and current. A DMM capable of measuring up to ± 12 V and ± 22 mA is required. A calibrated 6.5 digit DMM is recommended.

There are 88 calibration points required to calibrate the voltage and current on all four DAC channels, so automation of the procedure is highly recommended.

Voltage Adjustments

- 1 With the DMM disconnected from the L4451A, set the DMM to the 100V range or the lowest range that can measure 16V (do not use autorange).
- 2 Short the inputs to the DMM. The DMM reading is the offset voltage for the selected range. If the DMM has “null” capability, turn it on at this time. Otherwise, record the offset which will be subtracted from the subsequent voltage measurements.
- 3 Unsecure the instrument for calibration using the command:
`CALibration:SECure:STATe 0, <code>`
- 4 Connect channel 1 of the L4451A to the DMM as shown in [Figure 11-2](#). Set the DMM to measure DC volts.
- 5 Referring to [Table 11-3](#), set the first DAC calibration point using the command:
`CALibration:BEGin:VOLTage 1, (@<channel>)`
 For channel 1, the command is executed as:
`CALibration:BEGin:VOLTage 1, (@1001)`
- 6 Measure the DAC output on the DMM. Subtract the offset voltage measured in Step 2 from the reading. Write this value to the DAC using the command:
`CALibration:POINt? <value>`
 Note the DAC output which is now calibration point 2 ([Table 11-3](#)). Subtract the offset voltage from the new DMM reading and write the value to the DAC as above.
- 7 Repeat Step 6 until the nine voltage calibration points have been entered and measured. “0” is returned after the last calibration point (point 9) indicating the end of the sequence.
- 8 Separately connect L4451A channels 2, 3, and 4 to the DMM as shown in [Figure 11-2](#). Repeat Steps 5 through 7 for each channel until calibration points 1 through 9 have been measured and entered.

Table 11-3 L4451A DAC Voltage Calibration Points.

Calibration Point	Minimum Expected Value	Maximum Expected Value	Result
1	-0.5 V	0.5 V	
2	-10.0 V	-8.0 V	
3	-10.5 V	-8.5 V	
4	-11.0 V	-9.0 V	
5	-11.5 V	-9.5 V	
6	8.0 V	10.0 V	
7	8.5 V	10.5 V	
8	9.0 V	11.0 V	
9	9.5 V	11.5 V	

* Voltage calibration constants for the channel are saved in non-volatile memory after completion of this step.

Current Adjustments

- 1 With the DMM disconnected from the L4451A, set the DMM to the 100mA range or the lowest range that can measure 20 mA (do not use autorange).
- 2 The DMM reading is the current offset for the selected range. If the DMM has “null” capability, turn it on at this time. Otherwise, record the offset which will be subtracted from the subsequent current measurements.
- 3 Unsecure the instrument for calibration using the command:

```
CALibration:SECure:STATe 0, <code>
```

- 4 Connect channel 1 of the L4451A to the DMM as shown in [Figure 11-1](#). Set the DMM to measure DC current.

- 5 Referring to [Table 11-4](#), set the first DAC calibration point on channel 1 using the command:

```
CALibration:BEgin:CURRent 1, (@<channel>)
```

For channel 1, the command is executed as:

```
CALibration:BEgin:CURRent 1, (@1001)
```

- 6 Measure the DAC output on the DMM. Subtract the current offset measured in Step 2 from the reading. Write this value to the DAC using the command:
`CALibration:POINT? <value>` (measured current in Amps)
 Note the DAC output which is now calibration point 2 (Table 11-3). Subtract the offset current from the new DMM reading and write the value to the DAC as above.
- 7 Repeat Step 6 until the 13 current calibration points have been entered and measured. "0" is returned after the last calibration point (point 13) indicating the end of the sequence.
- 8 Separately connect L4451A channels 2, 3, and 4 to the DMM as shown in Figure 11-1. Repeat Steps 5 through 7 for each channel until calibration points 1 through 13 have been measured and entered.

Table 11-4 L4451A DAC Current Calibration Points.

Calibration Point	Minimum Expected Value	Maximum Expected Value	Result
1	-2.0 mA	2.0 mA	
2	-10.0 mA	-8.0 mA	
3	-10.9 mA	-8.0 mA	
4	-11.5 mA	-9.5 mA	
5	8.0 mA	10.9 mA	
6	9.0 mA	11.0 mA	
7	9.5 mA	11.5 mA	
8	-22.0 mA	-16.0 mA	
9	-22.0 mA	-16.0 mA	
10	-22.0 mA	-16.0 mA	
11	16.0 mA	22.0 mA	
12	16.0 mA	22.0 mA	
13*	16.0 mA	22.0 mA	

* Current calibration constants for the channel are saved in non-volatile memory after completion of this step.

L4452A Multifunction Module

Verification and calibration of the L4452A Multifunction Module is limited to channels 6 and 7 which are the DAC (voltage) output channels.

L4452A Verification

The test connection for verifying the DAC output voltage on channels 6 and 7 of the L4452A are shown in [Figure 11-3](#).

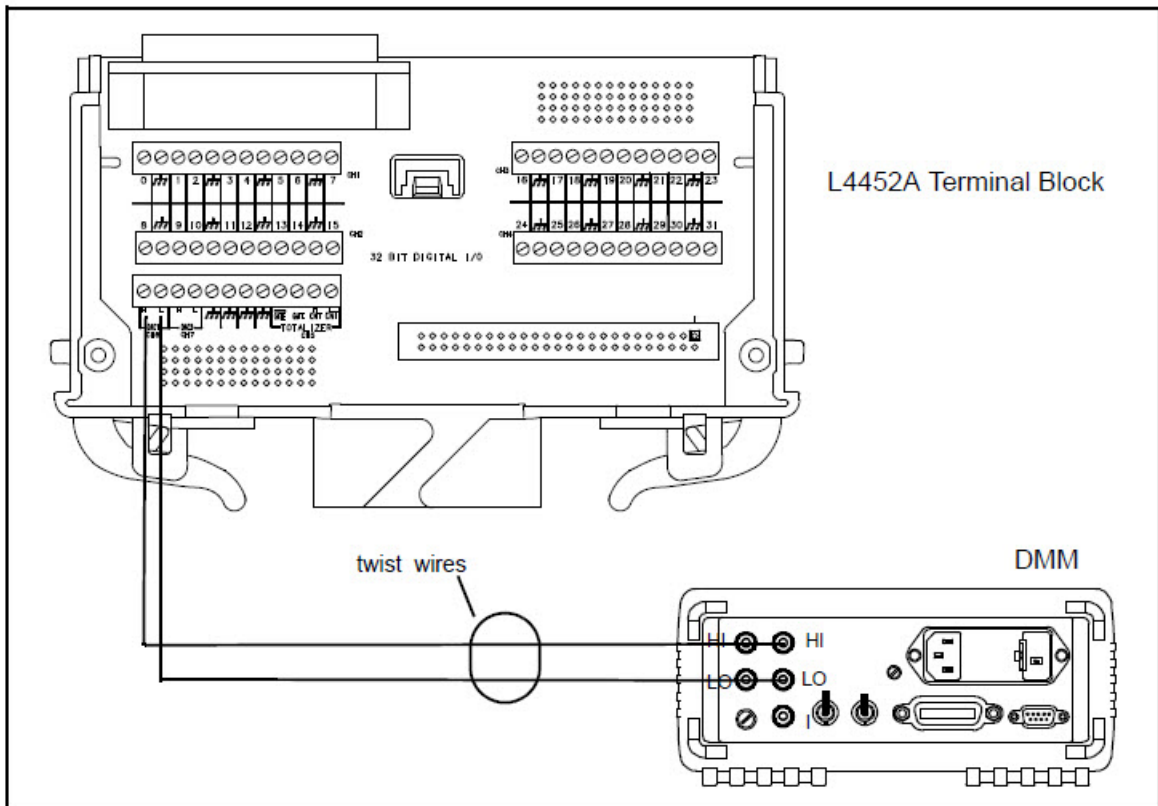

Figure 11-3 L4452A DAC Output Connections (Channels 6 and 7).

DAC Output Verification Test

This procedure is used to check the calibration of the DAC outputs on channels 6 and 7 of the L4452A. Verification checks are performed only for those output values with unique calibration constants.

- 1 With the DMM disconnected from the L4452A, set the DMM to the 100V range or the lowest range that can measure 16V (do not use autorange).
- 2 Short the inputs to the DMM. The DMM reading is the offset voltage for the selected range. If the DMM has “null” capability, turn it on at this time. Otherwise, record the offset which will be subtracted from the subsequent voltage measurements.
- 3 Connect channel 6 of the L4452A as shown in [Figure 11-3](#). Configure the L4452A to output the voltages listed in [Table 11-5](#). For each voltage level measured, subtract the offset voltage recorded in Step 2 as applicable. The results should be within the limits listed in [Table 11-5](#).
- 4 Repeat Step 3 for channel 7.

NOTE

It is not necessary to test the voltage output at the full rated 10 mA load.

Table 11-5 L4452A Output Voltage Levels (Channels 6 and 7).

Output Current	Error From Nominal (1 Year)
10 V	± 45 mV
0 V	± 20 mV
-10 V	± 45 mV

DAC Output Adjustment

The following analog output adjustment procedure is to be performed following a 1 hour warm up period.

This procedure sets a zero adjustment and a gain adjustment constant for each L4452A DAC output channel (6 and 7). You must complete all the adjustments on one channel before adjusting the other channel.

Voltage Adjustments

- 1 With the DMM disconnected from the L4452A, set the DMM to the 100V range or the lowest range that can measure 16V (do not use autorange).
- 2 Short the inputs to the DMM. The DMM reading is the offset voltage for the selected range. If the DMM has “null” capability, turn it on at this time. Otherwise, record the offset which will be subtracted from the subsequent voltage measurements.
- 3 Unsecure the instrument for calibration using the command:
`CALibration:SECure:STATe 0, <code>`
- 4 Connect channel 6 of the L4452A to the DMM as shown in [Figure 11-3](#). Set the DMM to measure DC volts.
- 5 Set the first DAC calibration point using the command:
`CALibration:BEgin:VOLTage 1, (@<channel>)`
 For channel 6, the command is executed as:
`CALibration:BEgin:VOLTage 1, (@1006)`
- 6 Measure the DAC output on the DMM. Subtract the offset voltage measured in Step 2 from the reading. Write the result to the DAC using the command:
`CALibration:POINt? <value>`
 Note the DAC output which is now calibration point 2. Subtract the offset voltage from the new DMM reading and write the value to the DAC using:
`CALibration:POINt? <value>`
- 7 Connect channel 7 of the L4452A to the DMM as shown in [Figure A- 3](#). Repeat Steps 5 and 6 for channel 7.

THIS PAGE HAS BEEN INTENTIONALLY LEFT BLANK.



This information is subject to change without notice. Always refer to the Keysight website for the latest revision.

© Keysight Technologies 2006-2021
Edition 5, November 2021

Printed in Malaysia



34989-90000

www.keysight.com