

# Keysight Technologies AN 1287-6

## Using a Network Analyzer to Characterize High-Power Components

Application Note

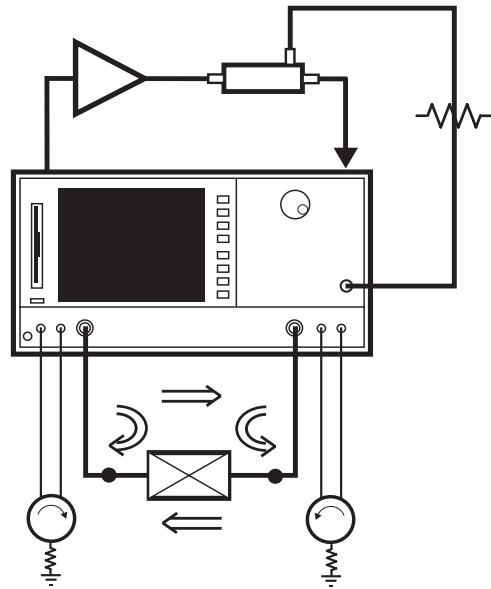



## Introduction

This application note describes linear and nonlinear measurements of high-power components and how to use a network analyzer for making them. It covers the power limitations of a network analyzer, and special network-analyzer equipment configurations for high-power measurements. How to improve the accuracy of high-power measurements and solve common problems when making high-power measurements are also described.

To get the most from this note, you should have a basic understanding of network analyzers and the measurements you can make with a network analyzer. For a basic review, please see the Appendix at the end of this note. Additional network analysis literature and study materials can be ordered through Keysight Technologies, Inc. A reference list is included at the end of the note.

### Defining high power

What might be considered “high-power device output” (e.g., 30 dBm or 1 Watt) in one application can be insignificant in another application, such as a radar test that uses devices with power levels in the 60 dBm (1,000 Watt) range. In this note, “high power” refers to a power level above the compression level and certainly above the damage level of a standard network analyzer. Therefore, a power amplifier with an output beyond the measurement capability of a standard network analyzer would be classified as a high-power device. We extend our definition to also include devices that require a drive level that is higher than a standard network analyzer can provide. So a high-power device is one that delivers more power than a standard network analyzer can measure, or requires more input power than the analyzer can provide.

## Table of Contents

Why high-power measurements can be challenging .....	4
Network analyzer configurations for measuring high-power devices .....	4
Configuration 1 .....	5
Configuration 2 .....	6
Configuration 3 .....	7
Configuration 4 .....	9
Configuration 5 .....	9
Configuration 6 .....	11
Additional configurations .....	11
Source leveling .....	12
Source leveling using power-meter calibration .....	12
Source leveling using external leveling .....	13
Calibration – purpose and types .....	14
Calibrating tips for best results .....	14
Dynamic accuracy .....	14
Choosing calibration power levels .....	14
Calibrating at one power level versus two power levels .....	14
Common problems of high-power measurements .....	15
Amplifiers with AGC loops .....	15
On-wafer devices (pulsed measurements) .....	15
Appendix .....	18
Network analyzers—definition and capabilities .....	18
Test sets .....	19
Calibration .....	19
Suggested reading .....	20

## Why high-power measurements can be challenging

Two main challenges exist when measuring high-power devices:

1. The measurements performed on high-power devices can be different than those required to characterize lower-power devices. Measurements of high-power devices also can be performed differently than those made at lower power levels.

Pulsed measurements are a good example. Measurements typically are not pulsed at lower power levels since device overheating tends not to be a problem. High power can heat up a device, affecting its measured characteristics. Many onwafer measurements, for example, require pulsed RF and pulsed DC bias, which reduces the average power dissipation and keeps the temperature of the device constant.

2. High-power measurements require special network-analyzer configurations. This can mean adding attenuation or a coupler between the output of the device under test (DUT) and the input of the test instrument to protect the receiver. It can also mean adding amplification to the stimulus signal if more power is required. Calibration and accurate measurements become significantly more complex as additional equipment is added to the test setup. In some configurations the additional hardware can make some types of calibration impossible, or limit the number of measurable parameters. For example, reverse S-parameters cannot be measured in some configurations. The inability to perform certain calibrations can limit the accuracy of the measurements.

This application note will show configurations ranging from those that are easy to assemble but may have limited accuracy or measurement capability, to more complex configurations that are very accurate and can make the same measurements as a standard network analyzer.

## Network analyzer configurations for measuring high-power devices

The high-power test configurations described in this note are designed to boost the power coming from the network analyzer's source as necessary, and also to protect components such as the receivers, couplers, and switches inside the network analyzer from excessive power levels.

To select the correct network analyzer configuration, you will need to consider the DUT and the required measurements and accuracy. This section shows high-power test configurations including the necessary hardware, how to set up and calibrate these configurations, and the advantages and limitations of each.

The configurations are ordered by the degree of measurement capability. In general, the increased capability results in increased complexity in the configuration. The first configuration is simple – it uses a standard network analyzer and doesn't require high drive power, which means the network analyzer's source does not need to be boosted. The other configurations measure devices that require high-power inputs and also have high-power outputs. Measuring these devices requires amplifying the network analyzer's source signal somewhere along the RF path before it reaches the DUT. The high output power also requires protection for the couplers, receivers, and switches inside the analyzer.

Configuration	Complexity	Available high-power measurements			Available calibrations	
		Booted source	Transmission only	Forward Transmission and reflection only	Forward/reverse	Full two-port Response
1	low				XX	X
2	low	X	X			X
3	medium	X	X			X
4	medium	X		X		X
5	high	X			X	X
6	high	X		X		X

## Configuration 1

### Configuration summary

- Low complexity
- No boosted source
- Forward and reverse measurements
- Full two-port or response calibration

### Setup and features

The simplest high-power devices to measure are those that have high gain but don't require high levels of drive power, and typically are tested in their linear region. Since these devices have high gain, the receiver must be protected from the high output power. An attenuator or coupler added between the output of the DUT and the analyzer's test port protects the receiver. If using a coupler, terminate the through arm of the coupler with a characteristic impedance load. The coupled arm of the coupler sends a small portion of the input signal to port 2. For a 20-dB coupler, the signal at the coupling arm is 20 dB less than the strength of the signal at the input. Determine the maximum power out of the DUT, subtract the power level required at the test port, and then choose the appropriate attenuator or coupler value. Choose components that are specified to handle your chosen power level.

Configuration 1 makes both forward and reverse, reflection and transmission measurements ( $S_{11}$ ,  $S_{12}$ ,  $S_{21}$ , and  $S_{22}$ ) if using an analyzer with an S-parameter test set.

### Calibration

This particular setup allows both forward and reverse measurements so full two-port error-correction, the most accurate calibration, can be performed. Calibration is performed at test-port 1 (or at the end of the cable attached to the port) and at test-port 2 (with the attenuator and any test cable). Include the attenuator or coupler on port 2 when performing the calibration to remove any mismatch between the attenuator and the analyzer's test port. Since calibration is performed with all hardware in place and all error terms corrected, the measurements can be as accurate as the standard analyzer.

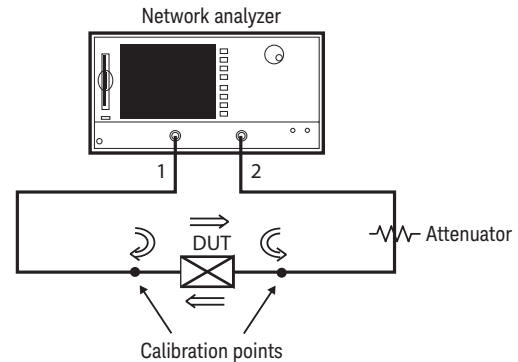

Configuration 1

The attenuator on port 2 degrades the uncorrected directivity of port 2 by twice the attenuation value. This limits the stability of the calibration and can make  $S_{22}$  measurements very noisy. If an  $S_{22}$  measurement is needed, calibrate at a higher power level, lower the power level when making forward measurements, and then raise the power level for the reverse measurements. There is more information on calibrating and power levels at the end of this note.

A common assumption is that the DUT's displayed gain should be increased by the amount of the attenuation, but remember that the calibration includes the attenuator so the values as displayed are correct.

## Configuration 2

### Configuration summary

- Low complexity
- Boosted source
- Forward transmission measurement only
- Response calibration only

### Setup and features

The simplest way to increase the power of the stimulus signal is to add a booster amplifier at the test port of a standard network analyzer. The input of the booster amplifier connects to the analyzer's source port and the output connects to the DUT (see Configuration 2). This configuration boosts the signal level going into the DUT without modifying the analyzer's built-in test set or having to add additional couplers. The analyzer's source power plus the gain of the booster amplifier gives the power available for testing the DUT. Protect the receiver by adding an attenuator or coupler between the output of the DUT and port 2 of the analyzer, as shown in Configuration 1.

Configuration 2 is convenient because it consists simply of a standard network analyzer. However, it has numerous limitations. When boosting the signal at port 1, only high-power transmission measurements in the forward direction (S21) and nonboosted reflection measurements in the reverse direction (S22) are possible. The position of the booster amplifier, with its high reverse isolation, makes forward reflection (S11) and reverse transmission (S12) measurements impossible. Nonboosted reverse reflection measurements can be made, but with limitations as described in Configuration 1.

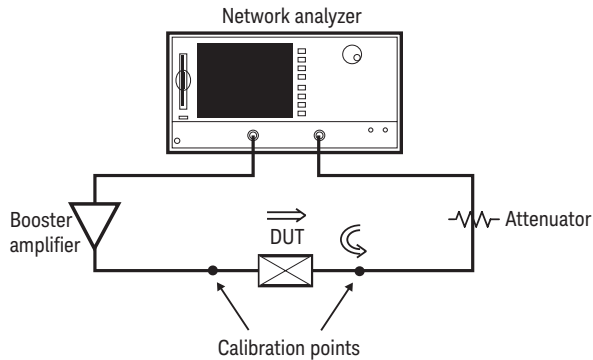

Configuration 2

The accuracy of Configuration 2 is limited because the network analyzer measures the reference signal before

the booster amplifier (coupling takes place inside the analyzer). As a result, any mismatch between the booster amplifier and the DUT is not ratioed out, and therefore ripple will appear in the measurement (Figure 1). This ripple can be significant due to the poor source match of the booster amplifier. Even the uncorrected source match of the network analyzer is likely to be much better than the source match of the booster amplifier.

The uncertainty associated with the measurement will depend upon the quality of the match between the booster amplifier and the DUT. In addition, any drift or power fluctuations associated with the booster amplifier will appear to be from the DUT since the reference signal is not measured after the booster amplifier. This configuration is best for analyzers that do not allow direct access to the R (reference) channel and when the accuracy of the measurements is not important. If the analyzer allows access to the R channel and the reference signal is coupled after the amplifier, a configuration that allows more accuracy is possible (see Configuration 3).

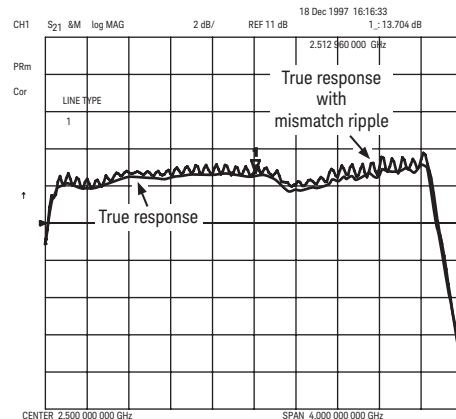

Figure 1. Ripple is caused by a mismatch between the DUT and the booster amplifier.

## Calibration

Only transmission response calibration is possible with this setup. The location of the booster amplifier does not allow the analyzer to make transmission measurements in the reverse direction, making a full two-port calibration impossible. Perform a response calibration by connecting the output of the booster amplifier to the attenuator or coupler on port 2. A basic response calibration does not remove mismatch errors due to the DUT – only the frequency response errors and any mismatch associated with the booster amplifier, the attenuator, and the analyzer. Since mismatch is not corrected for during calibration, even measurements made with a response calibration are limited in their accuracy.

In this setup you can improve the source match by adding an isolator between the booster amplifier and the DUT, or by adding attenuation. Adding an isolator between the output of the booster amplifier and the input of the DUT will remove the effects of any mismatch. If the booster amplifier has enough gain, a 3-dB or 6-dB attenuator at its output can be added to improve its output match.

Be sure to include the isolator or any attenuation in the calibration if you include it in the measurement setup. Also make sure that the isolator or attenuator can handle the power level being tested. Instead of using a high-power isolator, a circulator with a high-power load on its third port can be used.

## Configuration 3

### Configuration summary

- Medium complexity
- Boosted source
- Forward transmission measurement only
- Response calibration only

### Setup and features

Compared to Configuration 2, Configuration 3 improves measurement uncertainty and flexibility by measuring the incident signal after the booster amplifier rather than before. Measuring the incident signal after the booster amplifier ratios out the effects of any source mismatch.

Boost the analyzer's source power by connecting the booster amplifier to the "RF out" port on the analyzer. An external coupler connected to the output of the booster amplifier directs a portion of the boosted source signal to the R channel of the analyzer. This signal becomes the reference signal used in ratioing (Configuration 3).

Measuring the reference signal after the amplifier ratios out any mismatch ripple between the booster amplifier and the DUT and any drift or power fluctuations of the booster amplifier. The reverse isolation of the booster amplifier makes forward reflection measurements and reverse transmission measurements impossible.

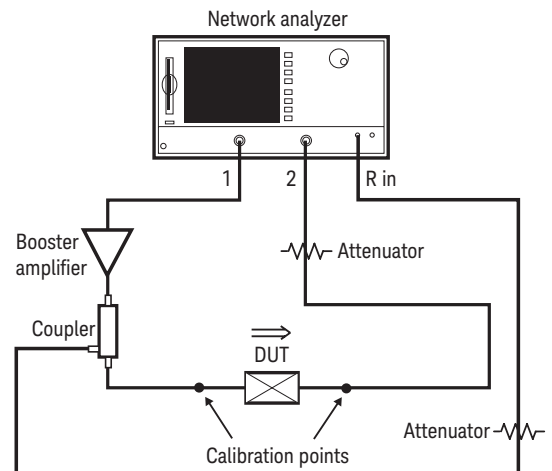

Configuration 3

In configurations where the user provides an R channel signal, determining the proper level is important. Too low

a signal level can be affected by noise and can cause phase-locking problems and inaccurate measurement results. Too high a signal level can be affected by receiver compression, causing inaccurate results. The receiver can also be damaged if the signal is high enough. To find the proper signal level for the R channel (a typical range might be 0 to -30 dBm) look at the analyzer's specifications. Then determine the signal level at the coupled arm of the coupler, and add attenuation to achieve the proper signal level at the R channel.

Normally, the analyzer attempts to phase-lock near the start frequency of the sweep. When the analyzer cannot phase-lock at the start frequency though, the analyzer performs a "pre-tune calibration" routine. During pre-tune calibration the analyzer attempts to phase-lock at a set frequency (100 MHz for the 8753D family), which could be below the start of the analyzer's sweep. The pre-tune calibration routine would be performed, for example, if the analyzer is switched to external reference mode without a signal attached to the R channel. When the external R channel signal is connected the analyzer is attempting to phase-lock at the pretune frequency (100 MHz). With a band-limited device in the R channel path (e.g., a booster amplifier) there may not be sufficient signal at this pretune frequency and phase-locking errors can occur on some analyzers.

On the 8753E network analyzer, turning "PLL Auto" off (located in the Service Modes menu) will stop the analyzer from performing the "pre-tune calibration" routine. Turning "PLL Auto" off rarely affects the accuracy of instrument measurements. Another way to prevent this phase-locking error is to use frequency-offset mode in the 8753E. In frequency-offset mode the analyzer assumes that a band-limited device is being measured, and as a result the analyzer never goes outside the sweep range to phase-lock. Setting LO = 0 Hz when in frequency-offset mode allows the analyzer to be used normally.

Band-limited devices in the R channel path may cause phase-locking problems in the Keysight 8720E family of network analyzers unless the analyzer has the high-power option (Option 085) or frequencyoffset option (Option 089). With either of these options, phase-locking is not a problem. This is because the internal reference switch switches to the internal signal when phase-locking. After the analyzer is phase-locked, the reference switch returns to the external signal and the analyzer is ready to make measurements.

## Calibration

Calibrating this configuration is similar to the calibration performed in Configuration 2. Only a response calibration is possible since only forward measurements can be made. Perform the response calibration by connecting the output of the coupler's through arm to the attenuator on test-port 2 of the analyzer.



## Configuration 4

### Configuration summary

- Medium complexity
- Boosted source
- Forward transmission and reflection measurements only
- Response calibration only

### Setup and features

High-power reflection and transmission measurements in the forward direction can be made on analyzers that provide access to the A channel and the R channel. Forward reflection measurements are possible by adding a reverse coupler between the coupler used for the R channel and the DUT. This reverse coupler, which is connected to the A channel, allows the forward reflection measurement.

### Calibration

Again only a response calibration is possible since a reverse measurement cannot be made. When performing the calibration, connect the output of the second coupler to the attenuator or output coupler so that the calibration includes all hardware.

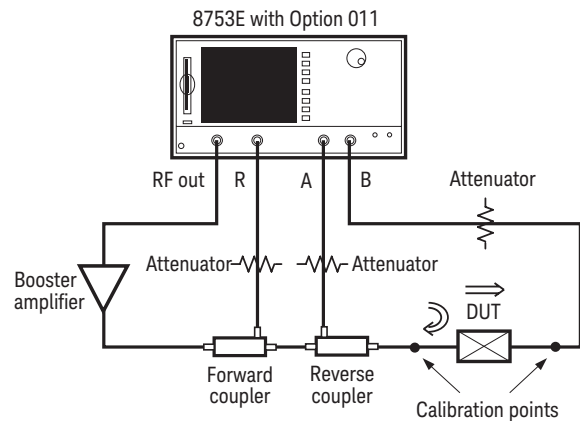

Configuration 4

## Configuration 5

### Configuration summary

- High complexity
- Boosted source
- Forward and reverse measurements
- Full two-port or response calibration

### Setup and features

The configurations presented up to now have made use of an analyzer's build-in test set, or include additional external hardware to make high-power measurements. Another approach is to modify the standard test set to make it more suitable for high-power measurements. Typically modifications to the internal test set are options that Keysight provides at time of purchase.

### High-power option

An example of a modified test set is the high-power option, Option 085, for the 8720E family of vector network analyzers. This option provides four features that allow for the measurement of higher power levels. These are: 1) access to the RF path between the source and the transfer switch; 2) direct access to the R channel; 3) direct access to the RF path between the transfer switch and the test ports; and 4) step attenuators between the couplers and the samplers on the A and B channels. The 8720E with Option 085 allows input power and output power up to +43 dBm at the test ports of the analyzer. For more information on the set-up of 8720E, Option 085, refer to the 8720E manual section *Making High Power Measurements with Option 085*.

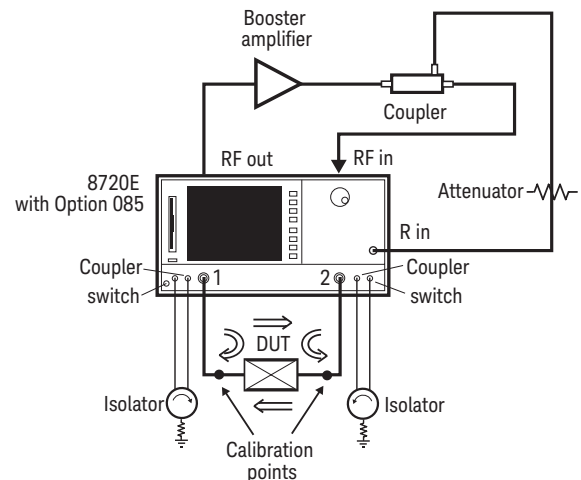

Configuration 5

## Forward and reverse measurements by amplifying the source signal

Access to the RF path between the source and the transfer switch allows the source signal to be amplified and then be switched between port 1 or port 2, allowing forward and reverse high-power measurements. The input of the booster amplifier connects to the “RF out” connector on the analyzer, and the output of the booster amplifier connects to the coupler. The coupled arm of the coupler connects to the R-channel input to provide the reference signal used for ratioing. To insure an optimum power level at the R receiver, add any needed attenuation between the reference coupler and the analyzer. The optimum power range for the receiver is provided by Keysight. The through arm of the coupler connects to the “RF in” connector on the analyzer. The amplified signal goes through the transfer switch, which directs it to either test port. Jumpers between the transfer switch and the test ports give access to the RF signal path. They allow the user to add high-power isolators to protect the transfer switch. Without isolators, signals with too much power can damage the transfer switch. Isolators on both sides of the transfer switch ensure that after the signal has been measured by the coupler any signal will be terminated, thereby protecting the switch.

## Protecting the receivers

The final feature of this high-power option is the internally controlled step attenuators that protect the receivers. Located after the couplers and before the receivers, these 55-dB step attenuators (with 5-dB increments) reduce the signal to an optimum level for the receiver. These attenuators are controlled from the front panel of the analyzer.

## Calibration

A major benefit of this configuration, besides the ability to do both forward and reverse measurements, is the ability to do full two-port vector error correction. Calibrating in this manner takes into account the effects of the hardware that has been added to the setup (isolators, amplifiers, couplers, etc.) and all errors associated with the analyzer and the measurement setup up to the point of calibration. Perform the calibration at the point where the DUT will be connected.

When using this configuration, it is extremely important not to damage any of the internal components because high power levels are inside the analyzer itself. Since amplification takes place before the transfer switch, the power-handling capabilities of the switch must be known. Analyzers that allow signal amplification before the transfer switch must specify how much power the switch can handle. Keysight specifies maximum power for the transfer switch for two conditions, when the switch is switching, and when the switch is not switching. Typically the nonswitching power-rating is higher than the switching power rating. The power-handling capability of all components in the RF path must be considered when making high-power measurements. When using this configuration, it is important to understand how the analyzer works and the power-handling capability of each component in the signal path.

## Configuration 6

### Configuration summary

- High complexity
- Boosted source
- Forward transmission and reflection measurements only
- Response calibration only

### Setup and features

Configuration 6 uses the same high-power test set as Configuration 5, but the hardware is rearranged so that measurements can be made at even higher power levels. Configuration 5 is desirable because it allows high-power measurements in both directions, but the maximum power level does not reach the test ports. Due to losses in the test set and the power limitations of the transfer switch, the power at the test ports is less than the couplers can handle. To test at power levels up to the level that the couplers can safely handle (+50 dBm), the 8720E with Option 085 is used in an alternate setup.

Amplification is done after the transfer switch and before the test port to get the maximum power possible at the test ports. This configuration allows higher power levels than possible using Configuration 5, but high-power measurements, both transmission and reflection, are possible only in the forward direction.

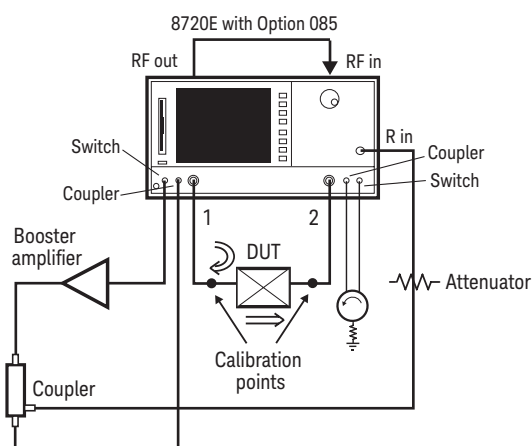

Configuration 6

## Calibration

Two-port vector error calibration cannot be used in this configuration. Since the external R channel is being used and is connected only to port 1, the reference signal is not accurate when doing a reverse sweep. This means only a response calibration can be done between test-port 1 and test-port 2. Since full two-port calibration cannot be done, this configuration should only be used if more power is needed than can be provided by Configuration 5.

## Additional configurations

Often Keysight can design test sets to specifically match your needs. Contact your local sales representative if you would like to investigate a specially configured test set. For example, solid-state switches may be substituted for mechanical switches in a high-power test set. High-power test sets usually use mechanical switches to handle higher power levels. If continuous switching is required, solid-state switches need to be used. Special configurations can include solid-state switches in high-power test sets if needed.

Other special configurations include high-power test sets that allow through-reflect-line (TRL) calibrations for noncoaxial measurements. Special configurations for applications that increase the power range over which a network analyzer sweeps such as compression measurements, are also available.

## Source leveling

When amplifiers operate in their nonlinear region, the measured response may differ from the true response of the amplifier. If the amplifier is operating in its nonlinear region, variations in the stimulus signal might not be duplicated at the output of the amplifier. In contrast, the response of an amplifier tested in its linear range is not affected by this level variation. By ratioing the response to the stimulus, the network analyzer removes the effects of the stimulus variation and displays the true performance of the amplifier.

However, if the amplifier is operating in its nonlinear range, at or near saturation, the amplifier does not produce an output signal with a variation proportional to the variation of the signal present at the input. The ratioing process in the network analyzer then creates an erroneous display (Figure 2).

To optimize measurements in the nonlinear region, a leveling scheme must be used to produce a stimulus signal with a frequency response that is as flat as possible.

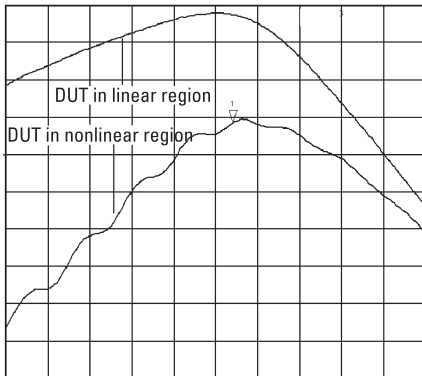

Figure 2. When a device operates linearly, its true response can be measured. However, a device that operates nonlinearly is affected by nonlevel input signals.

## Source leveling using power-meter calibration

Using power-meter calibration in continuous sampling mode is one way to level the source (Figure 3). The power level at each frequency point in the sweep is measured with a power meter. The network analyzer, connected to the power meter via GPIB, adjusts its source power until the power meter measures the desired power level. Then the measurement is made. Since the accuracy of the power meter is very high (uncertainty in the tenths of a dB range), you can have confidence that the power level is accurate as well as flat.

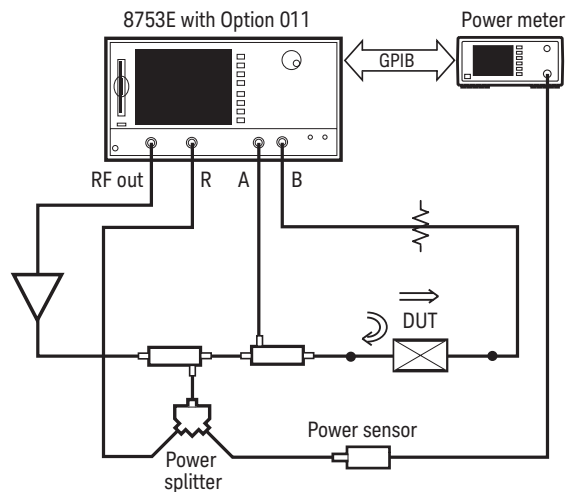

Figure 3. Power-meter calibration levels the source signal and removes the nonlinear ripple.

## Source leveling using external leveling

Using power-meter calibration for source leveling works well, but can slow down the measurements too much for some applications. A faster method of source leveling is external leveling. External leveling makes use of an external amplitude modulation (AM) input, available on some network analyzers. Adjusting the voltage at the AM input adjusts the analyzer's source power. By creating a leveling circuit that is external to the network analyzer, and adjusting the voltage to the external AM input, source power can be leveled on a real-time basis.

The external leveling circuit can be implemented in several ways. One common implementation is to create a circuit consisting of a detector diode and an operational amplifier. Changes in the power measured by the diode are detected by the operational amplifier circuit. The circuit connected to the AM input of the analyzer adjusts the source power by adjusting the voltage at the AM input (Figure 4).

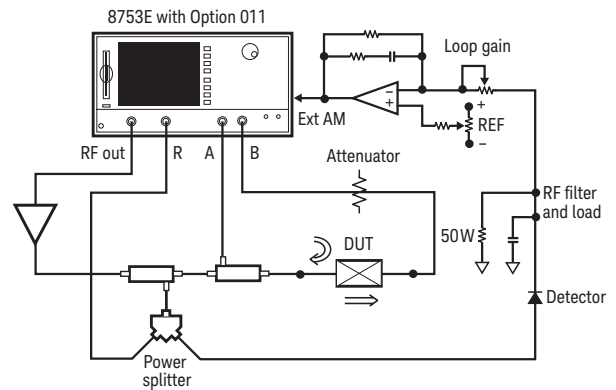

Figure 4. This circuit shows a common way to implement external leveling.

When using either power-meter calibration or external leveling, keep the source-leveling process active, just as it will be during the measurement. Then perform a response calibration as you would if source leveling was not used.

## Calibration—purpose and types

Calibrating an analyzer eliminates systematic errors and makes measurements more accurate. This note has shown calibrations for various configurations and where in the test setup to perform these calibrations. Of the two types of calibration discussed, full two-port calibration is the most accurate because it removes all systematic errors in the measurement setup, ideally up to where the DUT connects to the analyzer. Response calibration is less accurate and removes only the frequency-tracking errors. Frequency-tracking errors are associated with the differences in frequency response between one channel and another. In a full two-port calibration, the analyzer sweeps in both forward and reverse directions, while in a response calibration, the analyzer sweeps only in the forward direction.

## Calibration tips for best results

In addition to understanding what type of calibration is possible for each configuration and where to perform the calibration, it is important to understand how to get the most out of a calibration. The following topics discuss techniques and considerations for achieving the best calibration results.

### Dynamic accuracy

By examining the dynamic accuracy response of an analyzer, you can optimize the power levels for calibration and measurement. Dynamic accuracy refers to the uncertainty associated with calibrating at one signal level and measuring at another. The dynamic accuracy plot for the 8753E shows extremely low uncertainty (0.02 to 0.06 dB) if receiver power is between  $-10$  and  $-50$  dBm independent of the calibration power level (Figure 5). Perform calibration and measurements so that the signal level at the receiver is in this high-accuracy range. At lower signal levels, noise is a factor; at higher levels, receiver compression is a factor.

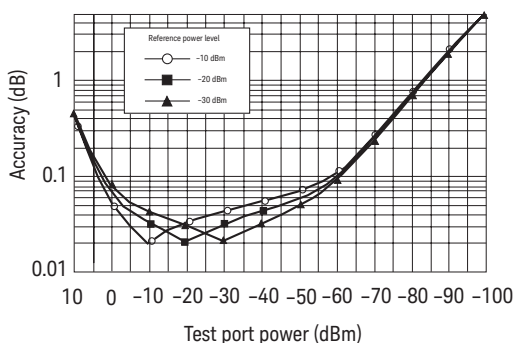

Figure 5. The 8753E dynamic accuracy

## Choosing calibration power levels

If you are measuring an amplifier and the output power level is higher than the input power level, at what power level should you calibrate: at the higher power level, the lower power level, somewhere in between the two levels, or at a different level for each port? Calibrating and measuring with the test port powers in the range of lowest uncertainty,  $-10$  to  $-50$  dBm for the Keysight 8753E, results in accurate measurements as shown above. Calibrating at the input (lower) power level can result in a power level at the output receiver that is too low, because attenuation is required to protect the analyzer during measurement of the DUT. Calibrating at the output (higher) power level might not be possible since the gain of the DUT can result in an output power level that the network analyzer's source together with the booster amplifier cannot generate. Therefore, you might need to perform some calibrations at a power level between the input power level and the output power level. In general, to reduce noise calibrate at the highest possible power below the onset of receiver compression.

## Calibrating at one power level versus two power levels

A response calibration is done at only one power level since only one forward sweep is made. Full two-port calibration, on the other hand, can be done at different power levels since both forward and reverse sweeps are made. The analyzer can calibrate one port using one power level and the other port using another power level to more accurately match the power levels present during the measurement of a DUT.

As an example, the open, short, and load standards for port one and the reverse through measurements may be made at the lower power level. The open, short, and load standards for port two and the forward through measurements could then be made at the higher power level. It is also possible to perform a full two-port calibration at one power level as in a response calibration. The power level used would be determined from the dynamic accuracy specification of the analyzer.

A final note on calibration: power-handling capabilities of the calibration standards can become an issue when calibrating at high power levels. The common standards used for calibration are the open, short, load, and through. The open, short, and through standards are not a problem since they do not dissipate any energy. The load, however, does dissipate energy so when you are calibrating make sure the standards can handle the power level.

## Common problems of high-power measurements

Some amplifiers contain an automatic-gain control (AGC) loop. AGC loops attempt to keep the output power of the amplifier constant by adjusting gain to account for variations at the input of the amplifier. Amplifiers with AGC loops can pose a problem when measured on some network analyzers, especially at high power levels.

### Amplifiers with AGC loops

Network analyzers sweep across the selected frequency range while holding the power at the desired constant power level. At the end of the sweep, some network analyzers might blank, or turn off the source, during the time it takes the analyzer to reset itself and set up for another sweep — the retrace time. Turning off the source is a problem for amplifiers containing an AGC loop.

When an amplifier with an AGC loop is measured and the input signal is turned off at the end of the sweep, the AGC loop of the amplifier compensates for the turned-off signal by increasing its gain to keep the output power level constant. When the sweep begins again, the network analyzer restores its signal, and there is power again at the input of the amplifier, which has ramped-up its gain. The momentary high output power can cause damage or destroy the amplifier or the analyzer's receiver if the AGC loop cannot respond quickly enough.

Using a network analyzer that keeps its power constant during retrace will reduce the possibility of destroying the device or damaging the analyzer. The 8753E keeps power constant except when switching frequency bands at 300 kHz and 3 GHz. The 8720E family of network analyzers allows the user to keep the power constant or to blank during retrace (the default is to have the power remain constant). The 8720E family will briefly blank during band changes at 2.55 GHz. The 8722D blanks at 20.05 GHz as well. Be aware that this blanking occurs if the analyzer sweeps across these bands.

### On-wafer devices (pulsed measurements)

A problem commonly encountered when measuring high-power on-wafer devices is the heating up of the DUT. Devices on-wafer tend to heat up quickly because they lack sufficient heatsinking. This heating up requires that the temperature of the DUT be controlled in some way since the response of a DUT may change as the temperature of the DUT increases. Two common ways to control heating up is to pause the network analyzer between measurements, or pulse the RF and/or DC bias signals so that a constant DUT temperature is maintained.

Presuming that a device will not overheat during a single sweep, pausing between sweeps can keep the average temperature within bounds. A testsequencing program that contains a user-defined pause between each measurement will do this automatically. More information on test sequencing is available in your network analyzer's user's guide. Pausing between sweeps dramatically slows down testing time and might not be practical in some situations. Pulsed measurements can be a better solution to the heating problem.

In some cases pulsed RF and DC-bias measurements might be needed rather than the usual CW measurements made with a network analyzer. Pulsed measurements are used for several reasons. As noted above, pulses can be configured so that an isothermal measurement is achieved. A pulsed signal might also be used because it is representative of the signals that the DUT encounters in actual use (radar is a good example of this), or if there is interest in the transient response of a device stimulated with a pulse, etc.

Pulsed measurements typically requires a test set designed for this purpose. The 85108 is an example of a network analyzer system designed for pulsed measurements.

While not common, it is possible to make pulsed RF measurements with a standard network analyzer under certain conditions. The ability to make pulsed measurements depends on the pulse repetition frequency (PRF) of the pulse used, relative to the IF bandwidth and the sampling rate of the network analyzer and the duty cycle of the signal. There are three cases to consider when determining if pulsed measurements are possible using a network analyzer. (Note that we are referring to finding a DUT's steady-state frequency response under pulse conditions, not a DUT's transient time-variant response to a pulse. A standard network analyzer cannot be used to measure the transient time-variant response to a pulse.)

1. The first case is when the PRF of the pulse is less than the IF BW of the analyzer. When the PRF is less than the receiver's IF BW, the pulse sidebands pass through the IF filter and the modulated RF (the pulse) cannot be measured (Figure 6). So for pulsed measurements with a PRF less than the IF BW of the analyzer, a standard network analyzer will give inaccurate results.

2. The next case is for a PRF greater than the IF BW, but less than the sampling rate of the analyzer's (ADC) analog-to-digital converter. Pulsed measurements are possible as long as the PRF does not generate a sideband at the sampling rate of the analyzer. For the 8753E and 8720E family, the ADC sampling rate is 16 kHz. If any PRF sideband occurs at 16 kHz, it will be downconverted and be sampled by the receiver (Figure 7). There-fore, signals with a PRF of 4 kHz, 8 kHz, or 16 kHz would not be allowed.

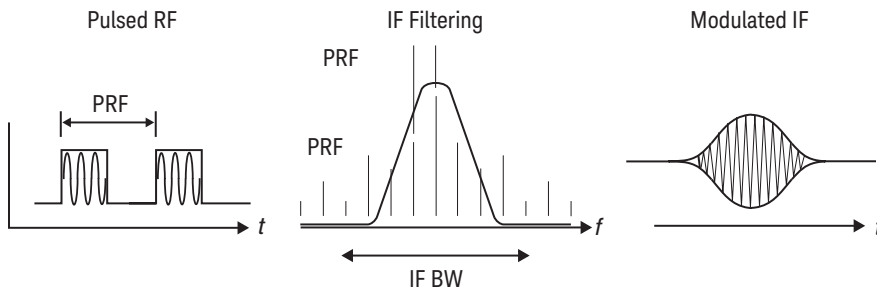

Figure 6. When the PRF is less than the IF bandwidth, pulse sidebands are measured in addition to the center spectral line.

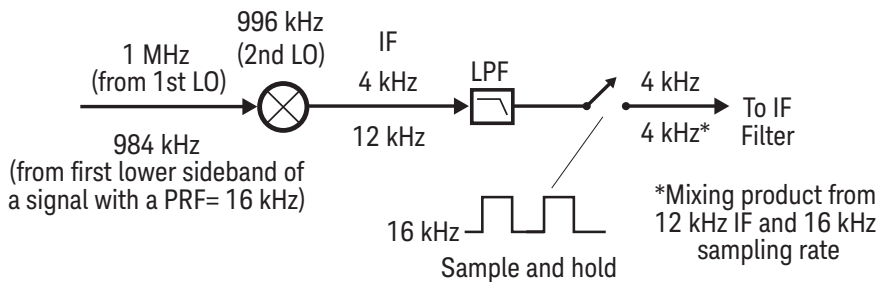

Figure 7. Pulse sidebands are downconverted and sampled by the receiver.



3. The final case is when the PRF is greater than the sampling rate of the analyzer's ADC. In this case, the IF filter measures only the center spectral line (carrier) of the pulsed-RF spectrum as if it were a CW signal in a nonpulsed network analyzer configuration (Figure 8). Since this type of measurement actually filters off the modulation sidebands, the PRF of the pulse does not affect the measurement. Only changes to the duty cycle affect the measurement.

Decreasing the duty cycle of the RF spreads the energy of this spectral line to the pulsed-RF sidebands. The magnitude of this center spectral line, will be proportional to the magnitude response of the DUT, but will also contain a magnitude decrease caused by the loss of the energy in the sidebands. The amount of the decrease caused by the energy loss to the sidebands is calculated using the formula:

$$\text{Pulse Desensitization} = 20 \cdot \log(\text{Duty Cycle})$$

This desensitization factor decreases the dynamic range of the measurement.

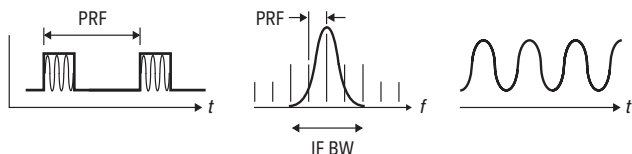

Figure 8. When PRF is greater than the IF bandwidth, pulse sidebands are rejected.

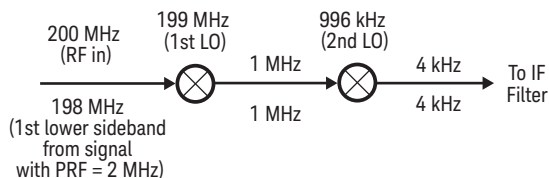

Figure 9. Any PRF which generates a sideband at the ADC sampling rate will be downconverted and sampled by the receiver.

When the PRF of the signal is greater than the ADC sampling rate, signals with a certain PRF must be avoided since image frequencies may mix with the receiver's LO to produce the IF frequency. For example, the 8753's first LO is tuned to 1 MHz below the RF test signal. For a 200-MHz RF test signal the LO is 199 MHz. Under pulsed conditions, say for a PRF equal to 2 MHz, the first lower sideband will fall at 198 MHz. This 198-MHz signal will mix with the 199-MHz LO to also produce a 1-MHz IF. Therefore, it is important to avoid signals with a PRF of  $2 \text{ MHz}/N$ , where  $N = 1, 2, 3, \dots$  (see Figure 9).

The hardware needed to make measurements under pulse conditions includes two splitters, a pulse generator, and a modulator. Connect a power splitter to the output of the analyzer's RF source output. One arm of the splitter connects to the reference (phaselock) channel since the phase reference channel cannot be pulsed. The other arm of the splitter goes to a pulse modulator. The pulsed RF is sent to a second splitter to make ratioed transmission measurements. Ratioing is necessary to remove the pulse transient response. The transmission measurement of interest is B/A (Figure 10).

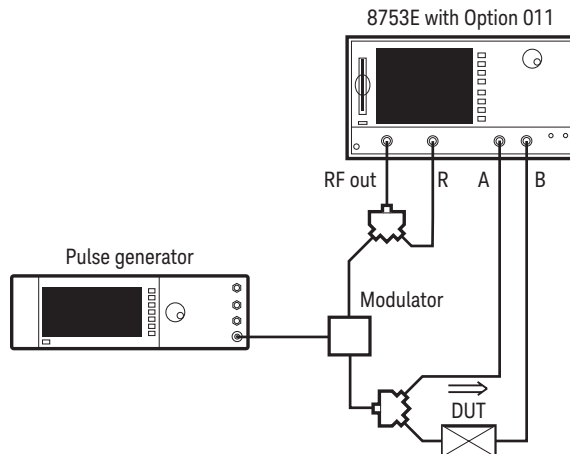

Figure 10. Using a pulse generator and a modulator, pulse measurements can be made with a standard network analyzer.

## Appendix

### Network analyzers— definitions and capabilities

Before discussing the measurements made with a network analyzer, it is important to have an understanding of a network analyzer block diagram and how analyzer makes measurements.

Network analyzers provide a wealth of information about a device, including its magnitude, phase, and group-delay response to a signal. The hardware inside a network analyzer includes a source for stimulus, signal-separation devices for measuring a portion of the incident signal and for separating signals traveling in opposite directions on the same transmission line, receivers for signal detection, and display/processing circuitry for reviewing results (Figure 11).

Network analyzers measure a portion of the source power to use as a reference signal. The remainder of the signal reaches the DUT where part of the signal reflects back from the device and part of the signal transmits through the device. The reflected signal creates a standing wave consisting of both forward and reverse traveling waves. The signal separation equipment allows for the detection of each of these waves separately. After measuring the reflected or transmitted signal, the analyzer ratios it with the reference signal to measure the characteristics of the DUT.

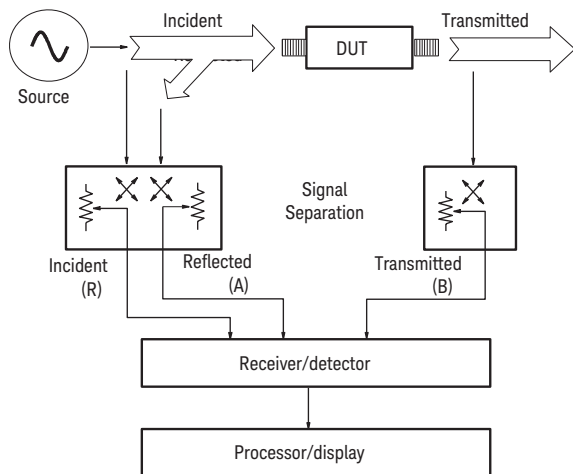
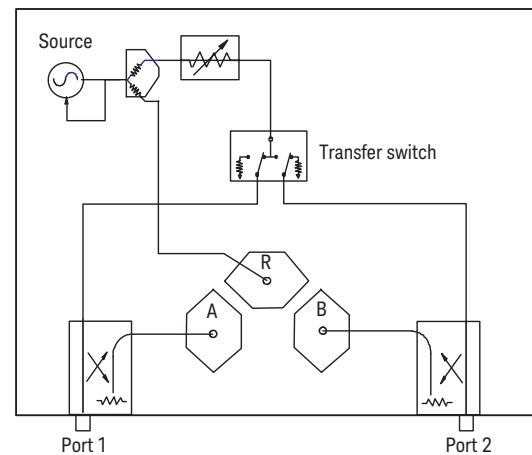
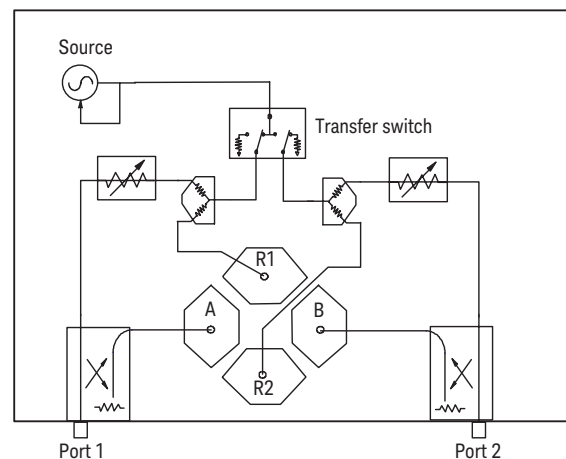

Figure 11. General network analyzer block diagram

A network analyzer consists of either three or four channels (Figure 12). In network analyzer terminology, a channel refers to the hardware used to detect a signal. There are one or two R channels in a network analyzer. A portion of the stimulus signal is coupled out and goes to the R channel for ratioing. The A channel denotes the channel associated with test port 1. The A channel measures the reflected signal when making a forward measurement (stimulus signal is at port 1), and measures the transmitted signal when making reverse measurements (stimulus signal is at port 2). The B channel, associated with test port 2, measures the transmitted signal during forward measurements and the reflected signal during reverse measurements.



3 Receivers



4 Receivers

Figure 12. Three versus four channels in a test set

## Test sets

There are many variations of network analyzers, but one of the most distinguishing factors of a network analyzer is its test set. A test set is a collection of switches and couplers that directs the source power and separates forward and reverse traveling signals. Some network analyzers, like the 8720E family of vector network analyzers, have an S-parameter test set with a transfer switch that directs the source power to either port 1 or port 2 – allowing the analyzer to make forward and reverse measurements. Other network analyzers, like the 8712C family of network analyzers, have a transmission/reflection (T/R) test set that does not have a transfer switch and source power only goes to port 1 – these test sets allow only forward measurements to be made (Figure 13). In the past, test sets were sometimes not included in the network analyzer, but almost all of today's network analyzers have a built-in test set.

## Calibration

Key to network analyzer measurements is calibration. Calibration does two things. First, it establishes a reference amplitude and reference phase at a point in the system. Second, it determines the accuracy of the measurement. Network analyzer calibration corrects for systematic errors (time invariant instrument and test setup errors) in the measurement setup. Ideally, calibration corrects for all errors up to the point where the DUT will be connected.

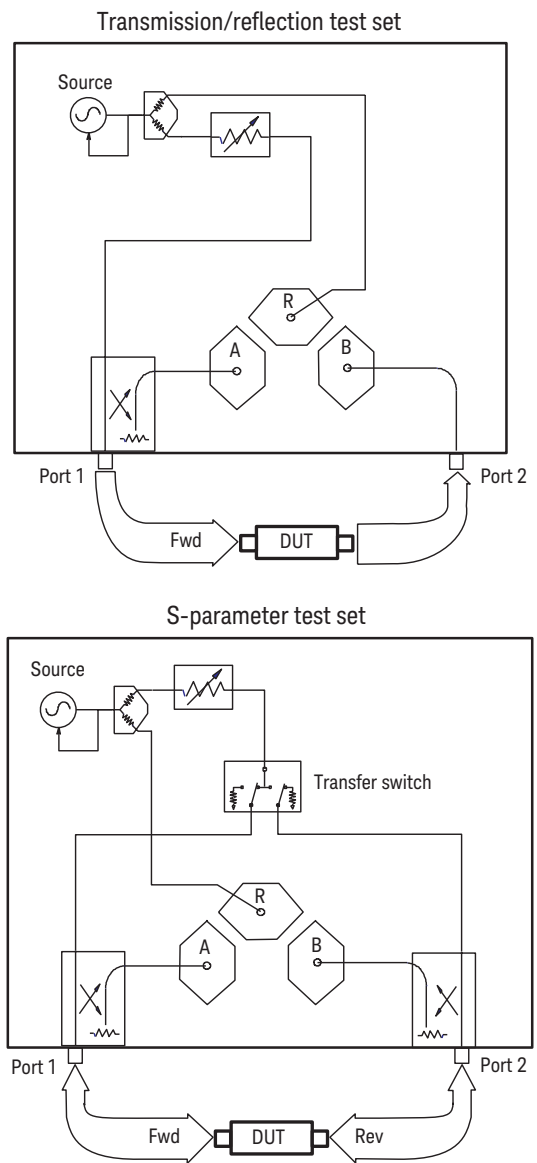

Figure 13. Transmission/reflection versus S-parameter test set

### Figure 13-top

- RF power always comes out of port 1
- Port 2 is always receiver
- Response, one-port cal available

### Figure 13-bottom

- RF power comes out of port 1 or port 2
- Forward and reverse measurements
- Two-port calibration possible

## Suggested Reading

*Understanding the Fundamental Principles of Vector Network Analysis*, Application Note 1287-1, literature number 5965-7707E, Keysight Technologies, 2014

*Exploring the Architectures of Network Analyzers*, Application Note 1287-2, literature number 5965-7708E, Keysight Technologies, 2014

*Applying Error Correction to Network Analyzer Measurements*, Application Note 1287-3, literature number 5965-7709E, Keysight Technologies, 2014

*Network Analyzer Measurements: Filters and Amplifier Examples*, Application Note 1287-4, literature number 5965-7710E, Keysight Technologies, 2014

*Improving Throughput in Network Analyzer Applications*, Application Note 1287-5, literature number 5966-3317E, Keysight Technologies, 2014

*8 Hints for Making Better Network Analyzer Measurements*, Application Note 1291-1, literature number 5965-8166E, Keysight Technologies, 2014

## Evolving Since 1939

Our unique combination of hardware, software, services, and people can help you reach your next breakthrough. We are unlocking the future of technology.

From Hewlett-Packard to Agilent to Keysight.



For more information on Keysight Technologies' products, applications or services, please contact your local Keysight office. The complete list is available at: [www.keysight.com/find/contactus](http://www.keysight.com/find/contactus)

### Americas

Canada	(877) 894 4414
Brazil	55 11 3351 7010
Mexico	001 800 254 2440
United States	(800) 829 4444

### Asia Pacific

Australia	1 800 629 485
China	800 810 0189
Hong Kong	800 938 693
India	1 800 11 2626
Japan	0120 (421) 345
Korea	080 769 0800
Malaysia	1 800 888 848
Singapore	1 800 375 8100
Taiwan	0800 047 866
Other AP Countries	(65) 6375 8100

### Europe & Middle East

Austria	0800 001122
Belgium	0800 58580
Finland	0800 523252
France	0805 980333
Germany	0800 6270999
Ireland	1800 832700
Israel	1 809 343051
Italy	800 599100
Luxembourg	+32 800 58580
Netherlands	0800 0233200
Russia	8800 5009286
Spain	800 000154
Sweden	0200 882255
Switzerland	0800 805353
	Opt. 1 (DE)
	Opt. 2 (FR)
	Opt. 3 (IT)
United Kingdom	0800 0260637

For other unlisted countries: [www.keysight.com/find/contactus](http://www.keysight.com/find/contactus) (BP-9-7-17)

**DEKRA Certified**  
ISO 9001 Quality Management System

[www.keysight.com/go/quality](http://www.keysight.com/go/quality)  
Keysight Technologies, Inc.  
DEKRA Certified ISO 9001:2015  
Quality Management System

### myKeysight

myKeysight  
[www.keysight.com/find/mykeysight](http://www.keysight.com/find/mykeysight)  
A personalized view into the information most relevant to you.

[http://www.keysight.com/find/emt\\_product\\_registration](http://www.keysight.com/find/emt_product_registration)  
Register your products to get up-to-date product information and find warranty information.

### KEYSIGHT SERVICES

Accelerate Technology Adoption.  
Lower costs.

Keysight Services  
[www.keysight.com/find/service](http://www.keysight.com/find/service)  
Keysight Services can help from acquisition to renewal across your instrument's lifecycle. Our comprehensive service offerings—one-stop calibration, repair, asset management, technology refresh, consulting, training and more—helps you improve product quality and lower costs.



Keysight Assurance Plans  
[www.keysight.com/find/AssurancePlans](http://www.keysight.com/find/AssurancePlans)  
Up to ten years of protection and no budgetary surprises to ensure your instruments are operating to specification, so you can rely on accurate measurements.

Keysight Channel Partners  
[www.keysight.com/find/channelpartners](http://www.keysight.com/find/channelpartners)  
Get the best of both worlds: Keysight's measurement expertise and product breadth, combined with channel partner convenience.

