

8590 Series Programming Compatibility Guide

Agilent Technologies ESA Spectrum Analyzers Option 290

**This manual provides documentation for the following
instruments with Option 290 installed:**

Agilent Technologies ESA-E Series

**E4401B (9 kHz - 1.5 GHz)
E4402B (9 kHz - 3.0 GHz)
E4404B (9 kHz - 6.7 GHz)
E4405B (9 kHz - 13.2 GHz)
E4407B (9 kHz - 26.5 GHz)**

and

Agilent Technologies ESA-L Series

**E4411B (9 kHz - 1.5 GHz)
E4403B (9 kHz - 3.0 GHz)
E4408B (9 kHz - 26.5 GHz)**



Agilent Technologies

Manufacturing Part Number: E4401-90279

Printed in USA

April 2001

© Copyright 2001 Agilent Technologies, Inc.

Notice

The information contained in this document is subject to change without notice.

Agilent Technologies makes no warranty of any kind with regard to this material, including but not limited to, the implied warranties of merchantability and fitness for a particular purpose. Agilent Technologies shall not be liable for errors contained herein or for incidental or consequential damages in connection with the furnishing, performance, or use of this material.

Warranty

This Agilent Technologies instrument product is warranted against defects in material and workmanship for a period of three years from date of shipment. During the warranty period, Agilent Technologies Company will, at its option, either repair or replace products that prove to be defective.

For warranty service or repair, this product must be returned to a service facility designated by Agilent Technologies. Buyer shall prepay shipping charges to Agilent Technologies and Agilent Technologies shall pay shipping charges to return the product to Buyer. However, Buyer shall pay all shipping charges, duties, and taxes for products returned to Agilent Technologies from another country.

Agilent Technologies warrants that its software and firmware designated by Agilent Technologies for use with an instrument will execute its programming instructions when properly installed on that instrument. Agilent Technologies does not warrant that the operation of the instrument, or software, or firmware will be uninterrupted or error-free.

LIMITATION OF WARRANTY

The foregoing warranty shall not apply to defects resulting from improper or inadequate maintenance by Buyer, Buyer-supplied software or interfacing, unauthorized modification or misuse, operation outside of the environmental specifications for the product, or improper site preparation or maintenance.

NO OTHER WARRANTY IS EXPRESSED OR IMPLIED. AGILENT TECHNOLOGIES SPECIFICALLY DISCLAIMS THE IMPLIED WARRANTIES OF MERCHANTABILITY AND FITNESS FOR A PARTICULAR PURPOSE.

EXCLUSIVE REMEDIES

THE REMEDIES PROVIDED HEREIN ARE BUYER'S SOLE AND EXCLUSIVE REMEDIES. AGILENT TECHNOLOGIES SHALL NOT BE LIABLE FOR ANY DIRECT, INDIRECT, SPECIAL, INCIDENTAL, OR CONSEQUENTIAL DAMAGES, WHETHER BASED ON CONTRACT, TORT, OR ANY OTHER LEGAL THEORY.

Contents

1. Getting Started

ESA Series, Option 290 Description	2
Command Differences	2
Running Software that Requires SCPI Commands	4
Service and Calibration	4
Rack Mounting	5
Option Required	7
Documentation for Option 290 ESA Spectrum Analyzers	8
Spectrum Analyzers with Option 290	8
ESA Spectrum Analyzer Updates	9
Updating the Firmware and Software	9
Uninstalling/Installing Option 290	10
Using Uninstall Key	10
Using Install Key	10
Creating the Installation Disks from the Web	10
Installing the Option 290 Software	10
Configuring Option 290	11
Troubleshooting the Installer	12
Installer Screen and Menu	13

2. Programming Command

Cross-References

8590 Series Compatible Command to Front-Panel Key	16
Front-Panel to 8590 Series Compatible Command	24
Functional Index	28

3. Programming Commands

Command Syntax	34
Programming Command Descriptions	42
ANNOT	
Annotation	43
Syntax	43
Description	43
Query Response	43
AT	
Attenuation	44
Syntax	44
Description	45
Query Response	45
AUNITS	
Amplitude Units	46
Syntax	46
Description	46
Query Response	46
AUTO	
Auto Couple	47
Syntax	47

Contents

Description	47
Differences	48
BLANK	
Blank Trace	49
Syntax	49
BML	
Trace B Minus Display Line	50
Syntax	50
Description	50
CAL	
Calibration	51
Syntax	51
Description	51
Differences	52
CF	
Center Frequency	53
Syntax	53
Description	53
Query Response	53
CLRAVG	
Clear Average	54
Syntax	54
Description	54
CLRW	
Clear Write	55
Syntax	55
Description	55
CLS	
Clear Status Byte	56
Syntax	56
Description	56
CONTS	
Continuous Sweep	57
Syntax	57
Description	57
CORREK	
Correction Factors On	58
Syntax	58
Query Response	58
Differences	58
COUPLE	
Couple	59
Syntax	59
Description	59
Query Response	59
DET	
Detection Mode	60
Syntax	60
Description	60

Contents

Query Response	60
DL	
Display Line	61
Syntax	61
Description	61
Query Response	61
DN	
Down	62
Syntax	62
Description	62
Differences	62
DONE	
Done	63
Syntax	63
Description	63
Query Response	63
FA	
Start Frequency	64
Syntax	64
Description	64
Query Response	64
FB	
Stop Frequency	65
Syntax	65
Description	65
Query Response	65
FOFFSET	
Frequency Offset	66
Syntax	66
Description	66
Query Response	66
FS	
Full Span	67
Syntax	67
Description	67
GRAT	
Graticule	68
Syntax	68
Query Response	68
ID	
Identify	69
Syntax	69
Query Response	69
IP	
Instrument Preset	70
Syntax	70
Description	70
LF	
Low Frequency Preset	72

Contents

Syntax	72
Description	72
LG	
Logarithmic Scale	73
Syntax	73
Description	73
Query Response	73
LN	
Linear Scale	74
Syntax	74
Description	74
LSPAN	
Last Span	75
Syntax	75
MDS	
Measurement Data Size	76
Syntax	76
Description	76
Query Response:	77
MEAN	
Trace Mean	78
Syntax	78
Query Response	78
MF	
Marker Frequency Output	79
Syntax	79
Description	79
MINH	
Minimum Hold	80
Syntax	80
Description	80
MKA	
Marker Amplitude	81
Syntax	81
Description	81
Query Response	81
Differences	81
MKACT	
Activate Marker	82
Syntax	82
Description	82
Query Response	82
MKCF	
Marker to Center Frequency	83
Syntax	83
Description	83
MKD	
Marker Delta	84
Syntax	84

Contents

Description	84
MKF	
Marker Frequency	86
Syntax	86
Description	86
Query Response	87
MKFC	
Marker Counter	88
Syntax	88
MKFCR	
Marker Counter Resolution	89
Syntax	89
Description	89
Query Response	89
MKMIN	
Marker Minimum	90
Syntax	90
MKN	
Marker Normal	91
Syntax	91
Description	91
Query Response	91
MKNOISE	
Marker Noise	92
Syntax	92
Description	92
Query Response	93
MKOFF	
Marker Off	94
Syntax	94
Description	94
MKP	
Marker Position	95
Syntax	95
Description	95
Query Response	95
MKPK	
Marker Peak	96
Syntax	96
Description	96
Differences	96
MKPX	
Marker Peak Excursion	97
Syntax	97
Query Response	97
MKREAD Marker Readout	98
Syntax	98
Description	98
Query Response	99

Contents

MKRL	
Marker to Reference Level	100
Syntax	100
MKSP	
Marker to Span	101
Syntax	101
Description	101
MKSS	
Marker to Step Size	102
Syntax	102
Description	102
MKTRACE	
Marker Trace	103
Syntax	103
Query Response	103
MKTRACK	
Marker Track	104
Syntax	104
Description	104
Query Response	104
ML	
Mixer Level	105
Syntax	105
Description	105
Query Response	105
MXMH	
Maximum Hold	106
Syntax	106
Description	106
PEAKS	
Peaks	107
Syntax	107
Description	107
Query Response	109
PREAMPG	
External Preamplifier Gain	110
Syntax	110
Description	110
Query Response	110
RB	
Resolution Bandwidth	111
Syntax	111
Description	111
Query Response	111
RCLS	
Recall State	112
Syntax	112
Description	112
Differences	112

Contents

REV	
Revision	113
Syntax	113
Query Response	113
RL	
Reference Level	114
Syntax	114
Description	114
Query Response	114
RMS	
Root Mean Square Value	115
Syntax	115
Query Response	115
ROFFSET	
Reference Level Offset	116
Syntax	116
Description	116
Query Response	116
RQS	
Service Request Mask	117
Syntax	117
Description	117
Query Response	118
Differences	118
SAVES	
Save State	119
Syntax	119
Description	119
SMOOTH	
Smooth Trace	120
Syntax	120
Description	120
SNGLS	
Single Sweep	122
Syntax	122
Description	122
SP	
Span	123
Syntax	123
Description	123
Query Response	124
SRCAT	
Source Attenuator	125
Syntax	125
Description	125
Query Response	125
SRCPOFS	
Source Power Offset	126
Syntax	126

Contents

Description	126
Query Response	126
SRCPSTP	
Source Power Level Step Size	127
Syntax	127
Description	127
Query Response	127
SRCPSWP	
Source Power Sweep	128
Syntax	128
Description	128
Query Response	129
SRCPWR	
Source Power	130
Syntax	130
Description	130
Query Response	130
SRCTK	
Source Tracking	131
Syntax	131
Description	131
Query Response	131
Differences	131
SRCTKPK	
Source Tracking Peak	132
Syntax	132
Description	132
SS	
Center Frequency Step Size	133
Syntax	133
Description	133
Query Response	134
Differences	134
ST	
Sweep Time	135
Syntax	135
Query Response	135
STB	
Status Byte Query	136
Syntax	136
Description	136
Query Response	136
STDEV	
Standard Deviation of Trace Amplitudes	137
Syntax	137
Description	137
Query Response	137
TA	
Trace A	138

Contents

Syntax	138
Description	138
TB	
Trace B	139
Syntax	139
Description	139
TDF	
Trace Data Format	140
Syntax	140
Description	140
TDF P.	140
TDF A	141
TDF I	143
TDF B	144
TDF M	145
Query Response	145
TH	
Threshold	146
Syntax	146
Description	146
Query Response	146
Differences	147
TM	
Trigger Mode	148
Syntax	148
Description	148
Query Response	149
TRA/TRB/TRC	
Trace Data Input and Output	150
Syntax	150
Description	150
Query Response	151
TS	
Take Sweep	152
Syntax	152
Description	152
UP	
Up	153
Syntax	153
Description	153
Differences	153
VAVG	
Video Average	154
Syntax	154
Description	154
Query Response	155
Differences	155
VB	
Video Bandwidth	156

Contents

Syntax	156
Description	156
Query Response	157
Differences	157
VBR	
Video Bandwidth Ratio	158
Syntax	158
Description	158
Query Response	158
Differences	158
VIEW	
View Trace	159
Syntax	159
Description	159
4. If You Have a Problem	
If you have a Problem	162
Before You Call Agilent Technologies	164
Check the Basics	164
Read the Warranty	165
Service Options	165
How to Get in Touch With Agilent Technologies	165
.....	166
How to Return Your Analyzer for Service	167
Service Tag	167
Original Packaging	167
Other Packaging	169

1 **Getting Started**

ESA Series, Option 290 Description

The ESA Series Option 290 allows the analyzer to be controlled using some of the 8590 Series programming commands, rather than SCPI commands. It is designed to replace 8590 Series analyzers in some automated systems, with minimal or no modification to the currently used measurement software. Only a portion of the 8590 Series commands are supported in this option (through GPIB or RS-232 interfaces).

The ESA Option 290 is not intended to be an absolute direct replacement for the 8590 Series analyzer. In the 8590 Series, a “predefined function” is an analyzer command that returns a number that can be operated on by other analyzer commands. “Predefined variables” follow the same idea, only the value to be passed as a parameter to the next command is stored in a variable. The Option 290 does not support this type of behavior, so any commands that originally act as predefined functions or variables, or that allow predefined functions or variables as arguments in the 8590 Series will not do so in this instrument. No user-defined functions, traces, or variables (FUNCDEF, TRDEF, VARDEF, or ACTDEF) can be used as arguments or commands in programs controlling this analyzer. Also, the behavior of certain commands that rely on the “active functions” (UP, DN, AUTO, etc.) might be slightly different.

Command Differences

The following table lists commands that behave differently in the ESA Option 290 than in the 8590 Series:

Table 1-1

Commands That Behave Differently in the ESA Option 290

Command	8590 Series	ESA Option 290
AUTO	As a stand-alone command, affects the parameter whose active function is enabled.	As a stand-alone command, affects the last relevant parameter whose remote command was sent.
CAL	CAL ALL initiates frequency and amplitude correction routines. CAL FREQ and CAL AMP perform only frequency or amplitude correction routines, respectively. CAL ON or OFF enables or disables the correction factors. CAL YTF initiates the correction routine for the YIG-tuned filter.	CAL ALL, CAL FREQ, and CAL AMP are equivalent and perform an alignment of all assemblies except the tracking generator (if installed). CAL ON or OFF toggles the state of the frequency corrections. CAL YTF aligns the RF section of the analyzer.

Table 1-1 Commands That Behave Differently in the ESA Option 290

Command	8590 Series	ESA Option 290
CORREK	Queries the state of the correction factors.	Queries the state of the frequency corrections.
DN	As a stand-alone command, affects the parameter whose active function is enabled.	As a stand-alone command, affects the last relevant parameter whose remote command was sent.
MKA	MKA can be used with a numeric argument that places the marker at that specified amplitude on the screen.	MKA is a query-only command. It will not accept arguments of any type.
MKPK	MKPK can be used to “Marker Peak” to the LO feedthrough (0 Hz).	MKPK cannot be used to “Marker Peak” to the LO feedthrough.
RCLS	Recalling the analyzer to previous state data (RCLS 9) is allowed.	Recalling the analyzer to previous state data (RCLS 9) is not allowed.
RQS	Units Key Pressed (bit 1) and End of Sweep (bit 2) are supported.	Units Key Pressed (bit 1) and End of Sweep (bit 2) are not supported.
SRCTK	All models require the use of this command if the tracking generator option is installed.	ESA models E4401B and E4411B do not use this command (tracking is automatically adjusted, continually).
SS	SS AUTO removes Center Frequency Step Size as the current active function, but does not affect the displayed value of the step size. Preset state is 100 MHz.	SS AUTO will affect the value of the Center Frequency Step Size. Preset state is hardware dependent.
TH	Clips signal responses below the threshold level so that nothing is displayed. AUTO deactivates display clipping. The TH level is used for peak marker movements and the PEAKS command even if the display clipping is off.	Signal responses below the threshold level are not clipped. The TH command is mapped to the Pk Threshold setting for peak marker searches. This allows the effect of the command on peak marker movements and the PEAKS command to be preserved.

Table 1-1 Commands That Behave Differently in the ESA Option 290

Command	8590 Series	ESA Option 290
UP	As a stand-alone command, affects the parameter whose active function is enabled.	As a stand-alone command, affects the last relevant parameter whose remote command was sent.
VAVG	Changing the average counter number to a higher number will not reset the count. Changing the average counter to a lower number will update the screen annotation. Range is 1 to 16384.	Changing the average counter number to a higher number will reset the count. Changing the average counter to a lower number will not update the screen annotation. Range is 1 to 8192.
VB	The minimum VB (video bandwidth) value is 1 Hz.	The minimum VB (video bandwidth) value is 30 Hz.
VBR	8590 E-Series preset state is 0.300.	Preset state is 1.0.

Running Software that Requires SCPI Commands

Once the Option 290 is installed, your instrument no longer responds (remotely) like an ESA analyzer. Consequently, if you need to run ESA calibration software, or any software that requires SCPI commands, Option 290 must be removed from your analyzer. Refer to [“Uninstalling/Installing Option 290” on page 10](#). After completing procedures that require the use of SCPI commands, it will be necessary to reinstall the option to achieve 8590 Series programming compatibility. Refer to [“Uninstalling/Installing Option 290” on page 10](#).

Service and Calibration

Since the *Agilent N2717A Performance Verification Software*, as well as the *Agilent Adjustment Software*, use SCPI command language, Option 290 will need to be removed prior to calibration or service of your ESA spectrum analyzer. When your analyzer is returned from an Agilent Technologies service center, you will need to reinstall Option 290. Refer to [“Uninstalling/Installing Option 290” on page 10](#).

Rack Mounting

To replace an 8590 Series spectrum analyzer with the ESA Series Option 290 spectrum analyzer, perform the following steps (Refer to [Figure 1-1](#)):

1. Disconnect all cables from the 8590 Series spectrum analyzer and remove the analyzer from the rack.
2. Remove the handle from the ESA analyzer by performing the following: Pull out on both sides of the handle and rotate it backwards until it is all the way to the rear position of the instrument. Rotate a few more degrees back (just below horizontal). Pull outwards simultaneously from both sides of the handle and remove.
3. Slide the analyzer into the support bracket (1) so that the front frame border fits into the support bracket opening.
4. Install the clamp (2) over the rear frame of the analyzer using one screw (3) to secure the analyzer in the support bracket. Make sure the anti-rotation tab has engaged the hole in the deck.

NOTE

Each slide rail (left and right) consists of three parts. The part that attaches to the rack is referred to as the stationary section. The part that attaches to the support bracket is referred to as the chassis section. The part referred to as the intermediate section, slides between the stationary and chassis sections.

5. Remove the chassis sections of the slide rail assemblies. Attach one to each side of the support bracket using four screws (6D) as shown in the figure. (The slide rails have a label including the letters RH for the right hand slide, or LH for the left hand slide.)
6. Install the stationary sections of the slide rails into the rack using 8 nuts (6A) and 8 screws (6B and 6C) as shown in the figure.
7. Install the hole plugs (5) in unused bulkhead connector holes. (The holes are designed to fit SMA (f) to SMA (f) bulkhead connector HP/Agilent 1250-1660.) The bulkhead connector holes can also be used to drill larger holes to fit other types of connectors, or to allow cables to pass through the bulkhead.
8. Install the support bracket handles (4) using 4 screws (6E). (If you don't want to install the handles, hole plugs (7) are provided.)
9. Install the analyzer assembly into the rack by first extending the intermediate sections to their fully extended and locked position. Engage the chassis section and slide the assembly into the rack until the lockouts have halted the insertion process. Depress the lockouts and continue the insertion to the fully seated position.

Getting Started
Rack Mounting

10. Secure the nuts (9) to the vertical rails of the rack.
11. Secure the analyzer assembly in the rack with 4 screws (8) and the nuts (9) that have been attached to the vertical rails of the rack.
12. Reconnect all cables to the analyzer.

Figure 1-1 Rack Mounting the ESA Spectrum Analyzer

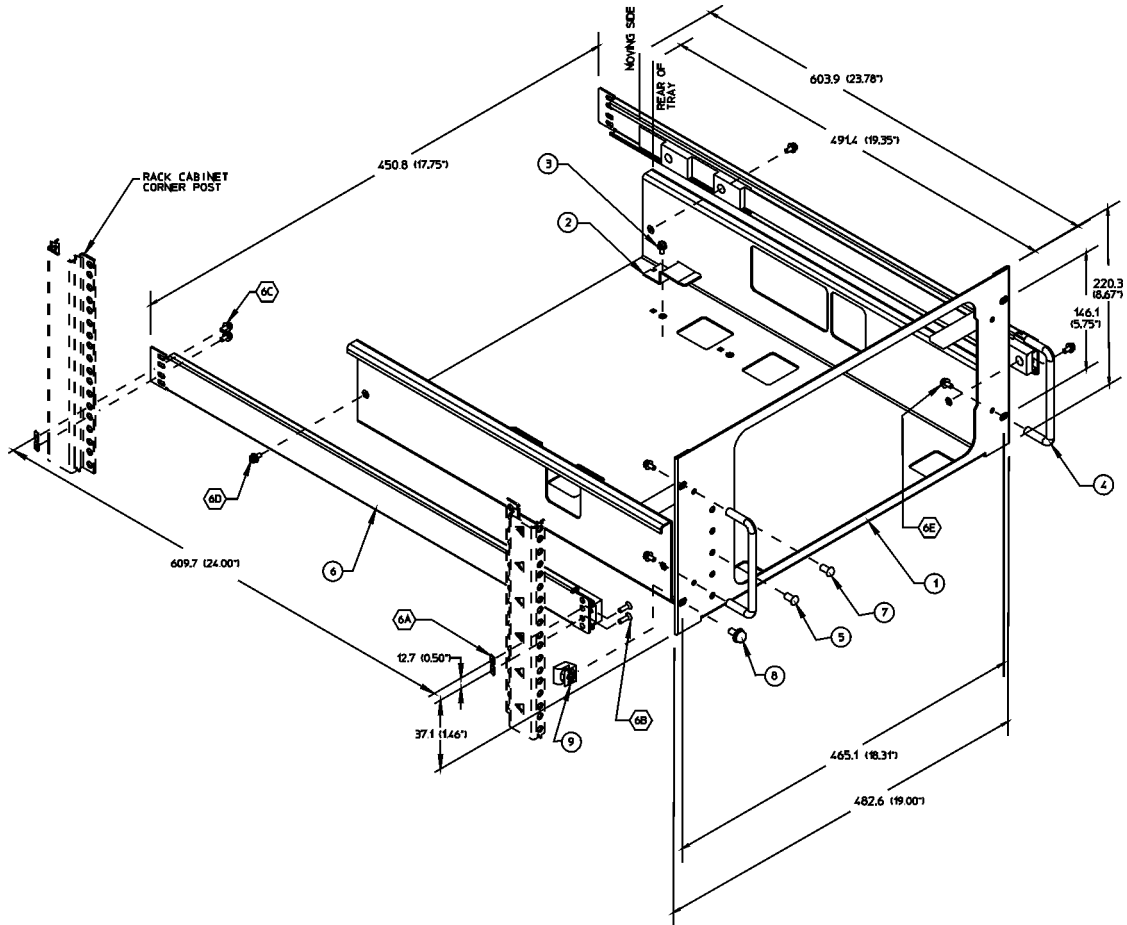

d172a

Option Required

One of the following Agilent ESA Series spectrum analyzers with option 290 is required to achieve 8590 Series spectrum analyzer programming compatibility.

Table 1-2 **Compatible Agilent ESA-E Series Spectrum Analyzers**

Model Number	Upper Frequency Range
E4401B	1.5 GHz
E4402B	3 GHz
E4404B	6.7 GHz
E4405B	13.2 GHz
E4407B	26.5 GHz

Table 1-3 **Compatible Agilent ESA-L Series Spectrum Analyzers**

Model Number	Upper Frequency Range
E4411B	1.5 GHz
E4403B	3 GHz
E4408B	26.5 GHz

NOTE The Option 290 software can also be used with the E4401B or E4411B spectrum analyzer to accomplish ESA-L1500A programming code compatibility.

Documentation for Option 290 ESA Spectrum Analyzers

Spectrum Analyzers with Option 290

When you purchase your ESA Series spectrum analyzer with the 8590 Series Programming Code Compatibility (Option 290), you receive the following materials:

Table 1-4 ESA Series Option 290 Documentation

Part Number	Part Description	Notes
Refer to the ESA WEB site for the current part number. http://www.agilent.com/find/esa/	<i>User's Guide</i>	Same as standard ESA
	<i>Measurement Guide</i>	Same as standard ESA
	<i>Reference Guide</i>	Same as standard ESA
	<i>Calibration Guide</i>	Same as standard ESA
	<i>Specifications Guide - E series</i>	E series only
	<i>Specifications Guide - L series</i>	L series only
	<i>Programmer's Guide</i>	Same as standard ESA
	<i>8590 Series Programming Compatibility Guide</i>	Option 290 only
	<i>8590 Series Programming Code Compatibility Installation Disk</i>	Option 290 only
	<i>Conversion Guide</i>	Same as standard ESA
	<i>Agilent ESA Spectrum Analyzers Documentation and Instrument Driver CD-ROM</i>	Does not include service documentation or software

ESA Spectrum Analyzer Updates

For the latest information about this instrument, including software upgrades, application information, and product information, please visit the URL listed below.

Updating the Firmware and Software

Updated versions of the Agilent ESA Spectrum Analyzers firmware and software will be available via several sources. Information on the latest firmware and software revision can be accessed through the following URL.

URL to Obtain Update Information

<http://www.agilent.com/find/esa/>

NOTE

If you have purchased Option 290 as an upgrade, the latest version of the ESA firmware has been included and should be loaded into your instrument before installing the Option 290.

Uninstalling/Installing Option 290

Using Uninstall Key

You may want to uninstall Option 290. To uninstall Option 290, press **System, More, Personalities, Uninstall**. Select the option and press **Uninstall Now**.

Using Install Key

You may want to install Option 290 or reinstall it after servicing or calibrating the analyzer. Before you can install the option, you will need an installation diskette or set of installation diskettes. The latest version of the installation disk set, at the time of purchase, was included with this programming compatibility guide.

To update an existing, previously installed Option 290, you may order the diskette(s) from Agilent Technologies or create a set from the Agilent internet site shown under [“ESA Spectrum Analyzer Updates” on page 9](#).

Creating the Installation Disks from the Web

To create the installation disks on-line, visit the Agilent internet site shown under [“ESA Spectrum Analyzer Updates” on page 9](#). Follow the instructions provided on the internet site for downloading the current Option 290 software and creating the installation disk set. (A firmware update may be needed to ensure that the firmware and the software are compatible.) After successfully creating the installation disk set, proceed with the following instructions for installing Option 290 in your instrument.

Installing the Option 290 Software

This procedure gives steps to install a new software option in an ESA Series Spectrum Analyzer using the internal floppy drive of the instrument. Screen messages display the update progress and give directions. The instrument will not need to be re-calibrated after this procedure since no changes are made to calibration or adjustment files.

If you have a problem with the installation process, refer to [“Troubleshooting the Installer” on page 12](#).

NOTE

When the installer starts up, it examines the instrument to ensure that all the required software and hardware options are present. If they are not, the installer will generate an error and you will not be able to install the option.

1. Insert disk one of the installation disk set into the disk drive located on the right side of the ESA front panel.
2. Press **System, More, Personalities, and Install**. The instrument will then load the installer from the disk drive. If there is no floppy in the drive, the incorrect disk is inserted, or there is no installer on the disk, the error “No install disk present in disk drive” will be shown.

Once the instrument has loaded the installer, the screen will change to the installer screen and the **Install Pers.** menu will be shown.
3. When the installer first starts up, it will show a popup message. Select **Verify Disks**.

NOTE

Once the installer has begun installing the software, any error will cause the whole option (including a previously installed version) to be removed from the instrument. Because of this, it is very important that you verify the disk prior to installing it. If any of the disks or files are bad, you will not be able to use the option until you obtain a new installation disk set and run the install using the new set.

4. If prompted, insert the next disk and press **Verify Disks** again.

When **Verify Disks** is running, the **Install Now** and **Exit Install** keys will be grayed out.
5. When the verification is complete and it has passed, press **Install Now** and the installation of the software will begin. Some of the disks may take only a short time to load or be skipped entirely, while others can take up to about 30 minutes to load.

When the installer is running, the **Verify Disks** and **Exit Install** keys will be grayed out.
6. If prompted, insert the next disk and press **Install Now** again.
7. Once the installation is complete, press **Exit Install**. If a problem occurs, refer to [“Troubleshooting the Installer” on page 12](#).

Configuring Option 290

[Figure 1-2](#) shows the menu map to configure your ESA Option 290 spectrum analyzer. Pressing **System, Configure Option 290** allows you to select the Remote ID for the instrument you are replacing. The last softkey in the menu shows the current analyzer’s model number and is the default setting after installation. The **Configure Option 290** key also allows you to toggle the Command Error. When **Command Err** is set to **On**, an error message will appear on the display when an unsupported command is sent. A Service Request interrupt for an illegal command will also be generated, which may cause a currently running test to stop. To avoid stopping a test, set the **Command Err** to **Off**. This will configure the analyzer to ignore any unsupported commands.

Figure 1-2 System Menu Map for Option 290

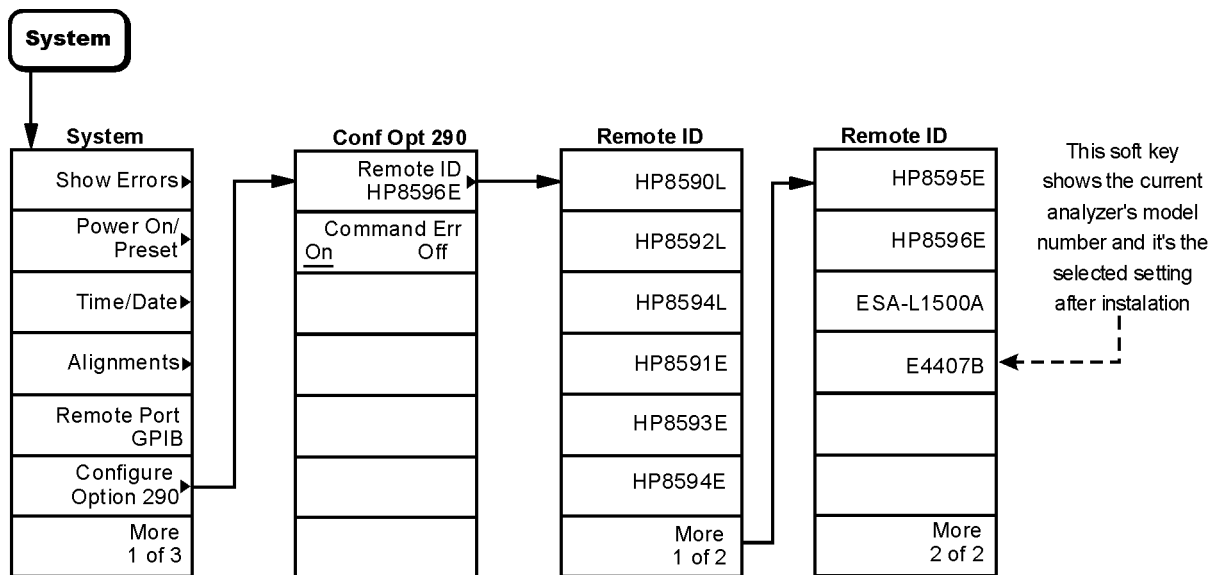

pl751b

Troubleshooting the Installer

If the installation process stalls or fails in another way, follow these steps to resolve your problem.

1. If the instrument stops the update process before all the disks are loaded proceed as follows:
 - a. Press **Exit Install** to abort the process.
 - b. Return to step 1 under [“Installing the Option 290 Software” on page 10](#).
2. If the instrument fails after repeating the installation procedure, get in touch with your nearest Agilent sales and service office for assistance. (Refer to [“How to Get in Touch With Agilent Technologies” on page 165](#)). Please provide the following information:

Model Number:

Serial Number:

State that you are having trouble installing Option 290.

Installer Screen and Menu

The top portion of the install screen is a table in which the files that are about to be installed are listed. The bottom portion of the screen contains information needed to track the progress of the install.

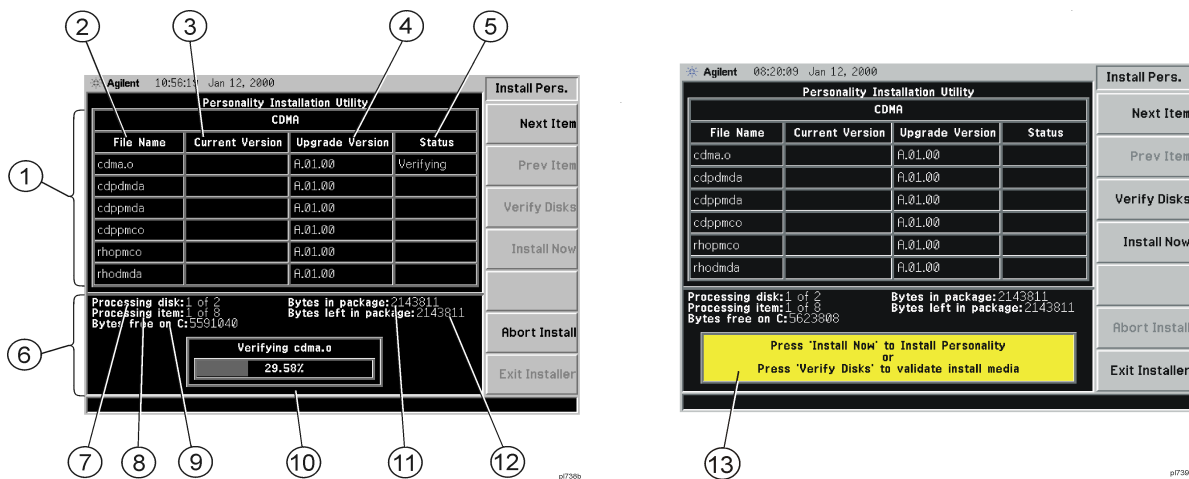

- 1 File Table** displays the files to be installed and various file information. If there are more than six files, **Next Item** and **Prev Item** allow you to scroll the table to view additional items.
- 2 File Name** displays the name of the files on the installation disk.
- 3 Current Version** displays the version of the file that is currently installed in the instrument. (This field will be blank if this file is not currently installed in the instrument or if the file is a data file that has no version.)
- 4 Upgrade Version** shows the version of the file on the install disk. This is the version of the file that will replace the currently installed version.
- 5 Status** is updated to reflect what the installer is doing to the current file as the install progress. The valid messages seen in this column are listed in [Table 1-5 on page 14](#).
- 6 Data Field** contains a status bar and various status information.
- 7 Processing disk** shows the disk that is currently being read.
- 8 Processing item** shows the file that is being processed by item number.
- 9 Bytes free on C** is the number of bytes currently free on the instrument C: drive.

- 10 Status Bar** contains a status bar that runs from 0 to 100% and tracks the progress of the current step and a message line displays the step that is currently being executed.
- 11 Bytes in package** lists the number of bytes in the install package/ fill.
- 12 Bytes left in package** lists the number of bytes left to be read.
- 13** Message and error popup window that displays over the status bar. Information in this box will prompt you for action required to proceed to the next phase of the installation. It may also inform you of errors in the installation process and may prompt you for action required to correct the problem.

Table 1-5 Installer Status Messages

Failed	This means that something has gone wrong while processing this item. It is a fatal error and the installation can not be completed. The installer will try to get the system back to a good state which may entail completely removing the currently installed personality.
Loading	The file is currently being copied from the install media to the instrument's file system.
Verifying	This may mean one of two things: <ol style="list-style-type: none"> 1. If "Verify Disks" was pressed then Verifying means that the installer is currently reading the install media and comparing the known checksums to ensure the data is good. 2. If "Install Now" was pressed, then Verifying means that the installer is reading what was just loaded to ensure the checksum is correct.
Loaded	This means that the data has been placed on the instrument disk but has not yet been registered with the firmware.
Installed	This means that the data has been loaded into the instrument and registered. The install for this file is complete.
Skipping	This means that the installer has determined that this file does not need to be loaded into the instrument.

2

Programming Command Cross-References

- [“8590 Series Compatible Command to Front-Panel Key” on page 16.](#)
- [“Front-Panel to 8590 Series Compatible Command” on page 24.](#)
- [“Functional Index” on page 28.](#)

8590 Series Compatible Command to Front-Panel Key

Table 2-1 8590 Series Compatibility Command to Corresponding Key Function

Command	Corresponding Key Function	Description
A1		See Table 3-3 on page 40 .
A2		See Table 3-3 on page 40 .
A3		See Table 3-3 on page 40 .
A4		See Table 3-3 on page 40 .
ANNOT	Annotation On Off	Turns on or off the screen annotation.
AT	Attenuation Auto Man	Specifies RF input attenuation.
AUNITS	Y Axis Units	Specifies amplitude units for input, output, and display.
AUTO	Auto Couple	Couples the active functions automatically.
BL		See Table 3-3 on page 40 .
BLANK	Blank 1, Blank 2, or Blank 3	Blanks trace 1, trace 2, or trace 3 and stops taking new data into the specified trace.
BML	2 – DL → 2	Subtracts display line from trace 2 and places the result in trace 2.
CA		See Table 3-3 on page 40 .
CAL	Alignments	Adjusts various settings that control the internal alignment of the instrument.
CF	Center Freq	Specifies center frequency.
CLRAVG	Video Average On Off	Restarts video averaging.
CLRW	Clear Write 1, Clear Write 2, or Clear Write 3.	Clears the specified trace and enables trace data acquisition.
CLS	none	Clears all status bits.

Table 2-1 8590 Series Compatibility Command to Corresponding Key Function

Command	Corresponding Key Function	Description
CONTS	Sweep Cont	Sets the spectrum analyzer to the continuous sweep mode.
CORREK	Freq Correct On Off	Queries the state of frequency corrections.
COUPLE	Coupling AC DC	Selects dc coupling or ac coupling.
CR		See Table 3-3 on page 40 .
CS		See Table 3-3 on page 40 .
CT		See Table 3-3 on page 40 .
CV		See Table 3-3 on page 40 .
DET	Detector	Selects the spectrum analyzer detection mode.
DL	Display Line On Off	Defines the level of the display line in the active amplitude units and displays the display line on the spectrum analyzer screen.
DN	↓ key	Reduces the function enabled in a previous command by the applicable step size.
DONE	none	Allows you to determine when the spectrum analyzer has started to execute all commands prior to and including DONE.
E1		See Table 3-3 on page 40 .
E2		See Table 3-3 on page 40 .
E3		See Table 3-3 on page 40 .
E4		See Table 3-3 on page 40 .
FA	Start Freq	Specifies the start frequency.
FB	Stop Freq	Specifies the stop frequency.
FOFFSET	Freq Offset	Specifies the frequency offset for all absolute frequency readouts such as center frequency.
FS	Full Span	Sets the frequency span of the spectrum analyzer to full span.
GRAT	Graticule On Off	Turns the graticule on or off.

Table 2-1 8590 Series Compatibility Command to Corresponding Key Function

Command	Corresponding Key Function	Description
ID	Show System	Returns the spectrum analyzer model number.
IP	Preset	Performs an instrument preset.
KSA		See Table 3-3 on page 40 .
KSB		See Table 3-3 on page 40 .
KSC		See Table 3-3 on page 40 .
KSD		See Table 3-3 on page 40 .
KSG		See Table 3-3 on page 40 .
KSH		See Table 3-3 on page 40 .
L0		See Table 3-3 on page 40 .
LF	Preset	Performs an instrument preset to the base band (band 0).
LG	Scale Type Log	Specifies the vertical graticule divisions as logarithmic units, without changing the reference level.
LN	Scale Type Lin	Specifies the vertical graticule divisions as linear units, without changing the reference level.
LSPAN	Last Span	Changes the spectrum analyzer's span to the previous span setting.
M1		See Table 3-3 on page 40 .
MA		See Table 3-3 on page 40 .
MDS	none	Specifies measurement data size as byte or word.
MEAN	none	Returns the mean value of the given trace in measurement units.
MF	none	Returns the frequency (or time) of the on- screen active marker.
MINH	Min Hold	Updates trace 3 elements with minimum level detected.
MKA	none	Specifies amplitude of the active marker.

Table 2-1 8590 Series Compatibility Command to Corresponding Key Function

Command	Corresponding Key Function	Description
MKACT	Select Marker 1 2 3 4	Specifies the active marker.
MKCF	Mkr → CF	Sets the center frequency equal to the marker frequency and moves the marker to the center of the screen.
MKD	Marker Delta	Activates the delta marker.
MKF	none	Specifies the frequency value of the active marker.
MKFC	Marker Count On Off	Turns on or off marker frequency counter.
MKFCR	Resolution Auto Man	Sets the resolution of the marker frequency counter.
MKMIN	Min Search	Moves active marker to minimum signal detected.
MKN	Marker Normal	Activates and moves the marker to the specified frequency.
MKNOISE	Marker Noise On	Displays the average noise level at the marker.
MKOFF	Marker All Off	Turns off either the active marker or all the markers.
MKP	none	Places the active marker at the given x-coordinate.
MKPK	Peak Search	Positions the active marker on a signal peak.
MKPX	Peak Excursn	Specifies the minimum signal excursion for the spectrum analyzer's internal peak- identification routine.
MKREAD	Readout	Selects the type of active trace information displayed by the spectrum analyzer marker readout.
MKRL	Mkr → Ref Lvl	Sets the reference level to the amplitude value of the active marker.
MKSP	Mkr Δ → Span	Sets the start and stop frequencies to the values of the delta markers.
MKSS	Mkr → CF Step	Sets the center-frequency step-size to the marker frequency.

Table 2-1 8590 Series Compatibility Command to Corresponding Key Function

Command	Corresponding Key Function	Description
MKTRACE	Marker Trace Auto 1 2 3	Moves the active marker to a corresponding position in trace 1, trace 2, or trace 3.
MKTRACK	Signal Track On	Moves the signal with an active marker to the center of the spectrum analyzer display and keeps the signal peak at center screen.
ML	Max Mixer Lvl	Specifies the maximum signal level that is applied to the input mixer for a signal that is equal to or below the reference level.
MT0		See Table 3-3 on page 40 .
MT1		See Table 3-3 on page 40 .
MXMH	Max Hold 1 or Max Hold 2	Updates trace elements with maximum level detected.
O1		See Table 3-3 on page 40 .
O2		See Table 3-3 on page 40 .
O3		See Table 3-3 on page 40 .
O4		See Table 3-3 on page 40 .
OFF	none	Turns off any applicable function activated by a previous command.
ON	none	Turns off any applicable function activated by a previous command.
PEAKS	none	Sorts signal peaks by frequency or amplitude stores the result in the destination trace, and returns the number of peaks found.
PREAMPG	Ext Amp Gain	Subtracts a positive or negative gain value from the displayed signal.
R1		See Table 3-3 on page 40 .
R2		See Table 3-3 on page 40 .
R3		See Table 3-3 on page 40 .
R4		See Table 3-3 on page 40 .
RB	Resolution BW Auto Man	Specifies the resolution bandwidth.

Table 2-1 8590 Series Compatibility Command to Corresponding Key Function

Command	Corresponding Key Function	Description
RC		See Table 3-3 on page 40 .
RCLS	none	Recalls spectrum analyzer state data from one of eight state registers in spectrum analyzer memory.
REV	Show System	Returns the date code of the firmware revision number in YYMMDD format.
RL	Ref Level	Specifies the amplitude value of the reference level.
RMS	none	Returns the root mean square value of the trace in measurement units.
ROFFSET	Ref Lvl Offst	Offsets all amplitude readouts without affecting the trace.
RQS	none	Sets a bit mask for service requests.
S2		See Table 3-3 on page 40 .
SAVES	none	Saves the currently displayed instrument state in spectrum analyzer memory.
SMOOTH	none	Smooths the trace according to the number of points specified for the running average.
SNGLS	Sweep Single	Selects single-sweep mode.
SP	Span	Changes the total displayed frequency range symmetrically about the center frequency.
SRCAT	Attenuation Auto Man	Attenuates the source output level.
SRCPOFS	Amptd Offset	Offsets the source power level readout.
SRCPSTP	Amptd Step Auto Man	Selects the source-power step size.
SRCPSWP	Power Sweep On Off	Selects sweep range of the source output.
SRCPWR	Amplitude On Off	Selects the source power level.

Table 2-1 8590 Series Compatibility Command to Corresponding Key Function

Command	Corresponding Key Function	Description
SRCTK	none	Adjusts tracking of source output with analyzer sweep.
SRCTKPK	none	Adjusts tracking of source output with analyzer sweep.
SS	CF Step Auto Man	Specifies center-frequency step size.
ST	Sweep Time Auto Man	Specifies the time in which the spectrum analyzer sweeps the displayed frequency range.
STB	none	Returns to the controller the decimal equivalent of the status byte.
STDEV	none	Returns the standard deviation of the trace amplitude in measurement units.
SV		See Table 3-3 on page 40 .
TA	none	Returns trace 1 data.
TB	none	Returns trace 2 data.
TDF	none	Formats trace information for return to the controller.
TH	Pk Threshold	Sets the minimum amplitude of signals that the marker identifies as a peak.
TM	Trig	Specifies trigger mode.
TRA, TRB, TRC	Trace 1, Trace 2, or Trace 3	Controls trace data input or output.
TS	Sweep Single	Starts and completes one full sweep before the next command is executed.
UP	↑ key	Increases the function enabled in a previous command by the applicable step size.
VAVG	Video Average On Off	Enables the video-averaging function, which averages trace points to smooth the displayed trace.
VB	Video BW Auto Man	Specifies the video bandwidth.

Table 2-1 **8590 Series Compatibility Command to Corresponding Key Function**

Command	Corresponding Key Function	Description
VBR	VBW/RBW Ratio	Specifies coupling ratio of video bandwidth to resolution bandwidth.
VIEW	View	Displays trace 1, trace 2, or trace 3, and stops taking new data into the viewed trace.

Front-Panel to 8590 Series Compatible Command

Table 2-2

Front -Panel Key Label to 8590 Series Compatibility Remote Command (Key labels not listed have no 8590 compatibility command.)

Key Label	Remote Command
Alignments (System)	CAL
Amplitude On Off (Source)	SRCPWR
Amptd Offset (Source)	SRCPOFS
Amptd Step Auto Man (Source)	SRCPSTP
Annotation On Off (Display, Preferences)	ANNOT
Attenuation Auto Man (AMPLITUDE or Source)	AT or SRCAT
Auto Couple	AUTO
2 – DL → 2 (View/Trace, Operations)	BML
Blank (View/Trace)	BLANK
BW/Avg	RB, VAVG
Center Freq (FREQUENCY)	CF
CF Step Auto Man (FREQUENCY)	SS
Clear Write (View/Trace)	CLRW
Coupling AC DC (Input/Output)	COUPLE
Detector (Det/Demod)	DET
Display Line On Off (Display)	DL
External (Trig)	TM
Free Run (Trig)	TM
Freq Correct On Off (System, Alignments)	CORREK
Freq Count	MKFC
Freq Offset (FREQUENCY)	FOFFSET
FREQUENCY	CF, FA, FB, SS, FOFFSET, MKTRACK
Full Span (SPAN)	FS

Table 2-2 Front -Panel Key Label to 8590 Series Compatibility Remote Command (Key labels not listed have no 8590 compatibility command.)

Key Label	Remote Command
Graticule On Off (Display, Preferences)	GRAT
Inverse Time (Marker, Readout)	MKREAD
Last Span (SPAN)	LSPAN
Line (Trig)	TM
Marker Delta (Marker)	MKD
Marker Off (Marker)	MKACT, MKOFF
Marker All Off (Marker)	MKOFF
Marker Count On Off (Marker)	MKFC
Marker Noise On Off (Marker, Function))	MKNOISE
Marker Normal (Marker)	MKN
Marker Trace Auto 1 2 3 (Marker)	MKTRACE
Max Hold (View/Trace)	MXMH
Max Mixer Lvl (AMPLITUDE)	ML
Min Hold (View/Trace)	MINH
Min Search (Search)	MKMIN
Mkr $\Delta \rightarrow$ Span (Marker \rightarrow)	MKSP
Mkr \rightarrow CF (Marker \rightarrow)	MKCF
Mkr \rightarrow CF Step (Marker \rightarrow)	MKSS
Mkr \rightarrow Ref Lvl (Marker \rightarrow)	MKRL
Negative Peak (Det/Demod, Detector))	DET
Next Peak (Search)	MKPK
Next Pk Left (Search)	MKPK
Next Pk Right (Search)	MKPK
Peak Excursn (Search, Search Param)	MKPX
Peak Search (Search, Search Param)	MKPK

Table 2-2

Front -Panel Key Label to 8590 Series Compatibility Remote Command (Key labels not listed have no 8590 compatibility command.)

Key Label	Remote Command
Period (Marker, Readout)	MKREAD
Power Sweep On Off (Source)	SRCPSWP
Preset	IP
Readout (Marker)	MKREAD
Ref Lvl Offst (AMPLITUDE)	ROFFSET
Ref Level (AMPLITUDE)	RL
Resolution (Freq Count)	MKFCR
Resolution Auto Man (Freq Count)	MKFCR
Resolution BW Auto Man (BW/Avg)	RB
Sample (Det/Demod, Detector)	DET
Scale/Div (AMPLITUDE)	LG
Scale Type Log Lin (AMPLITUDE)	LG, LN
Search	MKPK
Select Marker 1 2 3 4 (Marker)	MKACT
Show System (System)	ID, REV
Signal Track On Off (FREQUENCY)	MKTRACK
Source Amplitude (Source)	SRCPWR
SPAN	SP
Start Freq (FREQUENCY)	FA
Stop Freq (FREQUENCY)	FB
Sweep Cont Single (Sweep)	CONTS, SNGLS, TS
Sweep Time Auto Man (Sweep)	ST
Time (Marker, Readout)	MKREAD
Trace 1 2 3 ((View/Trace)	TRA, TRB, TRC
Trig	TM
VBW/RBW Ratio (BW/Avg)	VB
Video (BW/Avg, Average Type))	TM

Table 2-2 **Front -Panel Key Label to 8590 Series Compatibility Remote Command (Key labels not listed have no 8590 compatibility command.)**

Key Label	Remote Command
Video Average On Off (BW/Avg)	VAVG
Video BW Auto Man (BW/Avg)	VB
View 1 2 3 (View/Trace)	VIEW
Y Axis Units (AMPLITUDE)	AUNITS
Zero Span (SPAN)	SP

Functional Index

This functional index categorizes the 8590 Series compatible programming commands by the type of function that the command performs. Once the desired command is found, refer to the alphabetical listing of commands, in the following chapter, for more information about the command.

Table 2-3 **Functional Category to 8590 Series Compatible Remote Commands**

Function Category	Remote Command
ALIGNMENT	CAL CORREK
AMPLITUDE	AT AUNITS COUPLE LG LN PREAMPG ML RL ROFFSET
BANDWIDTH	RB VAVG VB VBR
CONFIGURATION	none
COUPLING	AUTO
DELETE, LOAD or SAVE	none
DISPLAY	ANNOT DL GRAT

Table 2-3 Functional Category to 8590 Series Compatible Remote Commands

Function Category	Remote Command
	TH
FREQUENCY	CF FA FB FOFFSET SS
INFORMATION	CLS ID REV RQS STB
INPUT and OUTPUT	TDF TRA TRB TRC
LIMIT LINES	none
MARKER	MDS MF MKA MKACTION MKCF MKD MKF MKFC MKFCR MKMIN MKN MKNOISE MKOFF MKP MKPK

Table 2-3 Functional Category to 8590 Series Compatible Remote Commands

Function Category	Remote Command
	MKPX MKREAD MKRL MKSP MKSS MKTRACE MKTRACK
MEASURE	none
OPERATOR ENTRY	DN UP
PRESET	IP
PRINTING	none
SOURCE	SRCAT SRCPOFS SRCPSTP SRCPSWP SRCPWR
SPAN	FS LSPAN SP
SPEAKER	none
SWEEP	CONTS SS ST
SYNCHRONIZATION	DONE TS
TRACE	BLANK BML CLRW

Table 2-3 Functional Category to 8590 Series Compatible Remote Commands

Function Category	Remote Command
	DET MINH MXMH TRA TRB TRC VAVG VIEW
TRACE MATH	CLRAVG PEAKS
TRIGGER	SNGLS TM TS

3 Programming Commands

Command Syntax

Command syntax is represented pictorially.

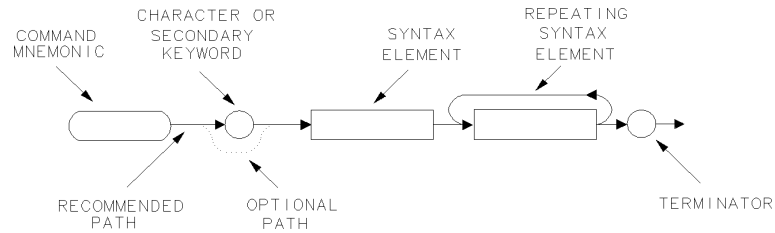

cu114e

- Ovals enclose command mnemonics. The command mnemonic must be entered exactly as shown.
- Circles and ovals surround secondary keywords or special numbers and characters. The characters in circles and ovals are considered reserved words and must be entered exactly as shown. See [“Characters and Secondary Keywords \(Reserved Words\)”](#) on page 36.
- Rectangles contain the description of a syntax element defined in [Table 3-1, “Syntax Elements.”](#)
- A loop above a syntax element indicates that the syntax element can be repeated.
- Solid lines represent the recommended path.
- Dotted lines indicate an optional path for bypassing secondary keywords or using alternate units.
- Arrows and curved intersections indicate command path direction.
- Semicolons are the recommended command terminators. Using semicolons makes programs easier to read, prevents command misinterpretation, and is recommended by IEEE Standard 728.

NOTE

Uppercase is recommended for entering all commands unless otherwise noted.

Syntax Elements are shown in the syntax diagrams as elements within rectangles. In the syntax diagrams, characters and secondary keywords are shown within circles or ovals. Characters and secondary keywords must be entered exactly as shown.

Table 3-1 Syntax Elements

Syntax Component	Definition/Range
Analyzer command	Any spectrum analyzer command in this chapter, with required parameters and terminators.
Character	Sp a b c d e f g h i j k l m n o p q r s t u v w x y z databyte.
Character & EOI	8-bit byte containing only character data and followed by end-or-identify (EOI) condition, where the EOI control line on GPIB is asserted to indicate the end of the transmission. END signifies the EOI condition.
Character string	A list of characters.
Data byte	8-bit byte containing numeric or character data.
Data byte & EOI	8-bit byte containing numeric or character data followed by end-or-identify (EOI) condition, where the EOI control line on GPIB is asserted to indicate the end of the transmission. END signifies the EOI condition.
Delimiter	\ @ ^ \$ % ; ! Matching characters that mark the beginning and end of a character string, or a list of spectrum analyzer commands. Choose delimiting characters that are not used within the string they delimit.
Digit	0 1 2 3 4 5 6 7 8 9
lsb length	Represents the least significant byte of a two-byte word that describes the number of bytes returned or transmitted. See msb length.
msb length	Represents the most significant byte of a two-byte word that describes the number of bytes returned or transmitted. See lsb length.
Number	Expressed as integer, decimal, or in exponential (E) form. Real Number Range: $\pm 1.797693134862315 \times 10^{308}$, including 0. Up to 15 significant figures allowed. Numbers may be as small as $\pm 2.225073858507202 \times 10^{-308}$ Integer Number Range: -32,768 through +32,767
Output termination	Carriage return(C _R) and line feed (L _F), with end-or-identify (EOI) condition. ASCII codes 13 (carriage return) and 10 (line feed) is sent via GPIB, then the end-or-identify control line on GPIB sets to indicate the end of the transmission.

Table 3-1 Syntax Elements

Syntax Component	Definition/Range
Units	Represent standard scientific units. Frequency Units: GHZ or GZ, MHZ or MZ, KHZ or KZ, HZ Amplitude Units: DB, DM, DBMV, DBUV, V, MV, UV, W, MW, UW Time Units: SC, MS, US Current Units: A, MA, UA Impedance Units: OHM

Table 3-2 Characters and Secondary Keywords (Reserved Words)

Element	Description
A	Amp (unit) or A-block data field
ABSHZ	Absolute Hz (unit)
AC	Alternating current
ALL	All
AM	Amplitude modulation
AMP	Amplitude
AMPCOR	Amplitude correction
AUTO	Auto couple or set to automatic
AVG	Average
B	8-bit byte or binary format
BW	Black and white
CNT	Counter-lock
COLOR	Color
DB	Decibel (unit)
DBM	Absolute decibel milliwatt (unit)
DBMV	Decibel millivolt (unit)
DBUV	Decibel microvolt (unit)
DC	Direct current
DELTA	Delta
DISP	Display
DM	Absolute decibel milliwatt (unit)

Table 3-2 Characters and Secondary Keywords (Reserved Words)

Element	Description
DMY	Day, month, year format
DN	Decreases parameter one step size
DUMP	Dump
EXT	External trigger
FIXED	Fixed
FLAT	Flat
FMD	Frequency modulation demodulator
FM	Frequency modulation
FMV	Frequency modulation detection
FREE	Free run
FREQ or FRQ	Frequency
GHZ	Gigahertz (unit)
GZ	Gigahertz (unit)
HI	Highest
HPIB	GPIB
HZ	Hertz (unit)
I	I-block data field
INT	Internal or integer
IP	Instrument preset
IST	Inverse sweep time
KHZ	Kilohertz (unit)
KZ	Kilohertz (unit)
LAST	Last state
LIMILINE	Limit line
LINE	Line trigger
LOAD	Load operation
LOWER	Lower limit line
M	Measurement units
MA	Milliamp (unit)

Table 3-2 Characters and Secondary Keywords (Reserved Words)

Element	Description
MDY	Month, day, year format
MHZ	Megahertz (unit)
MS	Millisecond (unit)
MTR	Meter
MV	Millivolts (unit)
MW	Milliwatt (unit)
MZ	Megahertz (unit)
NEG	Negative
NH	Next highest peak
NL	Next peak left
NONE	No units
NR	Next peak right
NRM or NORMAL	Normal
OA	Output amplitude
OFF	Turns off function
ON	Turns on function
P	Parameter units
PER	Period
PKAVG	Peak average
PKPIT	Peak pit
POINT	Point
POS	Positive
PSN	Position
RS232	RS-232 interface
SA	Signal analysis
SC	Seconds (unit)
SLOPE	Slope
SMP	Sample detection mode
SP	Space

Table 3-2 Characters and Secondary Keywords (Reserved Words)

Element	Description
SR	Stimulus response
STATE	State register
STEP	Step key ability
STORE	Store
SWT	Sweep time
TG	Tracking generator
TRA	Trace A
TRB	Trace B
TRC	Trace C
UA	Microamp (unit)
UP	Increases the parameter one step size
UPLOW	Upper and lower limit lines
UPPER	Upper limit line
US	Microseconds (unit)
UV	Microvolts (unit)
UW	Microwatt (unit)
V	Volts (unit)
VID	Video trigger
W	Watts or word (for MDS command)
*	Asterisk (used as a wildcard)
;	Semicolon (ASCII code 59)
,	Comma (ASCII code 44)
0	Off (command argument)
1	On (command argument)
50	50 Ω
75	75 Ω
?	Returns a query response containing the value or state of the associated parameter. The query response is followed by a carriage-return/line-feed.

The following table lists alternate commands that provide compatibility with commands used by the HP 8566A/B, HP 8568A/B, and HP/Agilent 70000 Series instruments. Only the alternate commands that are supported by ESA Spectrum Analyzer Series, Option 290, are listed.

Table 3-3 Summary of Alternate Compatible Commands

Alternate Command	Descriptions	8590 Series Compatible Command
A1	Clear write trace 1	CLRW TRA
A2	Max hold trace 1	MXMH TRA
A3	Store and view trace 1	VIEW TRA
A4	Store and blank trace 1	BLANK TRA
BL	2 – DL → 2	BML
CA	Coupled input attenuator	AT AUTO
CR	Coupled resolution bandwidth	RB AUTO
CS	Coupled step size	SS AUTO
CT	Coupled sweep time	ST AUTO
CV	Coupled video bandwidth	VB AUTO
E1	Peak search	MKPK HI
E2	Enter marker into center frequency	MKCF
E3	Enter marker delta into center frequency step size	MKSS
E4	Enter marker amplitude into reference level	MKRL
KSA	dBm amplitude units	AUNITS DBM
KSB	dBmV amplitude units	AUNITS DBMV
KSC	dB μ V amplitude units	AUNITS DBUV
KSD	Volt amplitude units	AUNITS V
KSG	Video average on	VAVG ON
KSH	Video average off	VAVG OFF
L0	Display line off	DL OFF
M1	Marker off	MKOFF
MA	Marker amplitude	MKA?

Table 3-3 Summary of Alternate Compatible Commands

Alternate Command	Descriptions	8590 Series Compatible Command
MT0	Marker track off	MKTRACK OFF
MT1	Marker track on	MKTRACK ON
O1	Output format, in real number format	TDF P
O2	Output format, in binary format, 2 bytes (word) per element	TDF B;MDS W
O3	Output format, in measurement data format	TDF M
O4	Output format, in binary format, 1 byte per element	TDF B;MDS B
R1	Activates illegal command service request only	RQS 32
R2	Activates end-of-sweep, illegal command	RQS 36
R3	Activates broken hardware, illegal command	RQS 40
R4	Activates units key pressed, illegal command	RQS 34
RC	Recall state	RCLS
S2	Sweep single	SNGLS
SV	Save state	SAVES

Programming Command Descriptions

To find a programming command that performs a particular function, refer to the chapter of cross-reference information where commands are categorized by function. Once the desired command is found in the functional index, refer to the description for the command in this chapter.

ANNOt Annotation

Turns on or off the display annotation.

Syntax

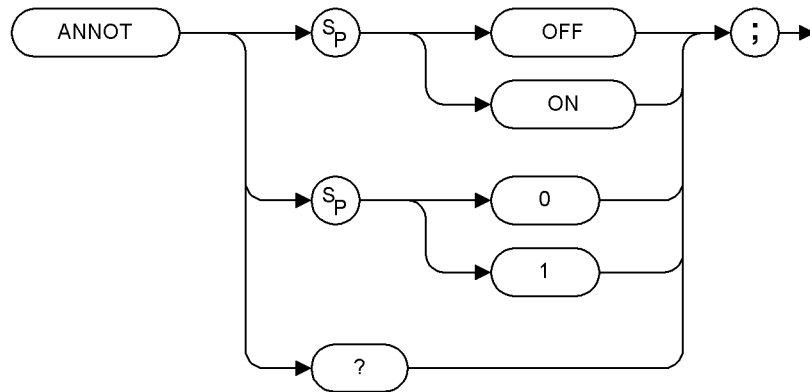

XANNOt

Preset State: ANNOt ON

Description

The ANNOt command turns on or off all the words and numbers (annotation) on the spectrum analyzer display (except for the softkey labels).

Query Response

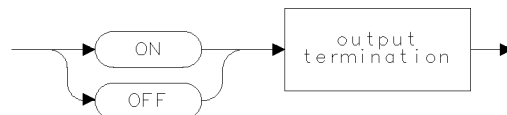

Q02

AT Attenuation

Specifies the RF input attenuation.

Syntax

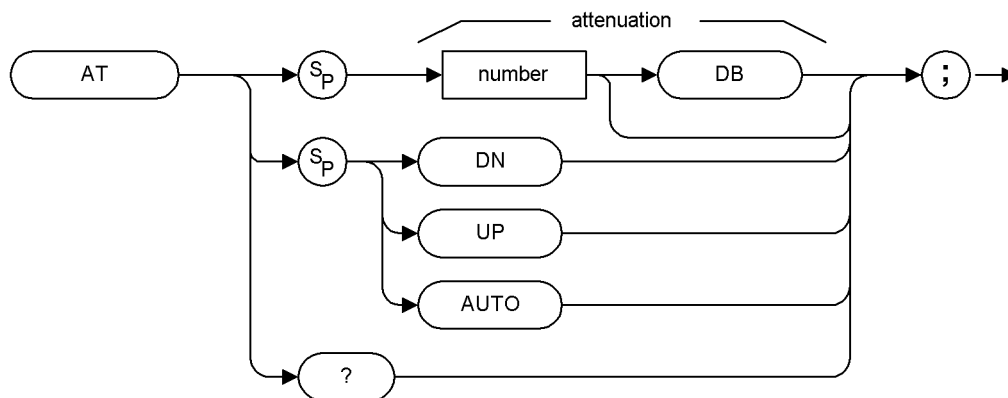

XAT

Item	Description/Default	Range
Number	Any real or integer. Default units are dB.	Input attenuator range of spectrum analyzer

Preset State: 10 dB

Step Increment: in 10 dB steps

Description

The AT command specifies the input attenuation in 10 dB steps. Normally, the input attenuator is coupled to the reference level. When a continuous wave signal is displayed with its peak at or below the reference level, the coupling keeps the mixer input level at or below the specified level (also see the command “ML”). The AT command allows less than the specified value at the mixer input.

When the attenuation is increased with the AT command, the reference level does not change. If the attenuation is decreased from the coupled value using the AT command, the reference level will be decreased. When the reference level is changed using the RL command, the input attenuation changes to maintain a constant signal level on the screen if attenuation is auto-coupled. Using auto-coupling resets the attenuation value so that a continuous wave signal displayed at the reference level yields -10 dBm (or the specified mixer level) at the mixer input.

CAUTION

Signal levels above +30 dBm will damage the spectrum analyzer.

Query Response

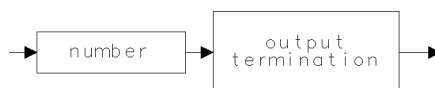

QQ1

AUNITS Amplitude Units

Specifies the amplitude units for input, output, and display.

Syntax

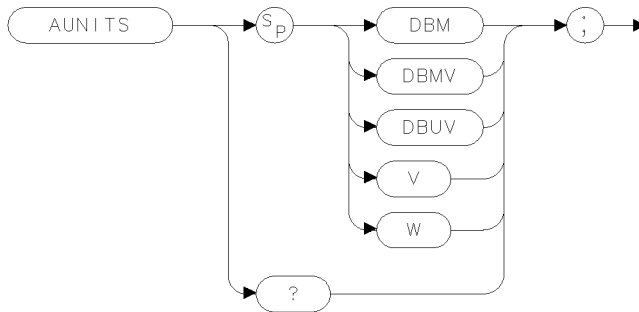

XAUNITS .

Description

The AUNITS command sets the amplitude readouts (reference level, marker, display line, and threshold) to the specified units. Different amplitude units can be set for log and linear amplitude scales.

Query Response

The query response returns the current amplitude units for the current amplitude scale.

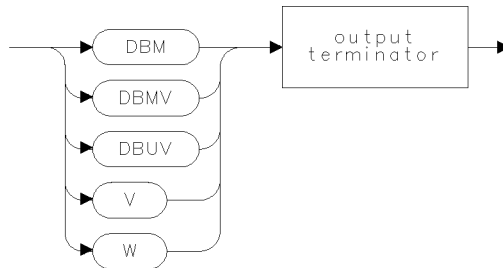

QAUNITS .

AUTO Auto Couple

Couples functions which have an AUTO parameter and sets the sweep coupling mode.

Syntax

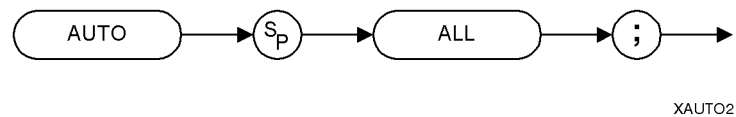
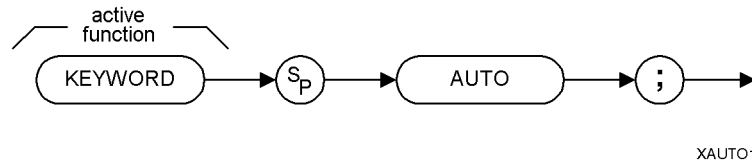

Description

The result of the AUTO command depends on the command it acts upon. The following are the functions that are affected by the AUTO parameter:

AT	couples attenuation to the reference level
DL	turns off display of line but does not change the value of the display line
MKF	turns off marker
MKFCR	deactivates use of user-supplied counter resolution value without changing the value of resolution
MKN	turns off marker
RB	couples resolution bandwidth to frequency span
SRCPSTP	sets source power step to 0 (its value may, however, be displayed as 10)
SRCPSWP	turns off power sweep
SRCPWR	turns off source power
SS	couples step size to frequency span

ST	couples sweep time to frequency span
VAVG	stops averaging
VB	couples video bandwidth to resolution bandwidth
VBR	sets the video to bandwidth ratio to 0.3

Individual functions can be coupled by entering the keyword for the command before AUTO, (for example, "AT AUTO;").

AUTO has no effect if the active function is not in the above list.

Executing "AUTO;" if no functions are active couples all functions.

Differences

8590 Series: As a stand-alone command, affects the parameter whose active function is enabled.

ESA Option 290: As a stand-alone command, affects the last relevant parameter whose remote command was sent.

BLANK **Blank Trace**

Blanks Trace 1, trace 2, or trace 3 and stops taking new data into the specified trace.

Syntax

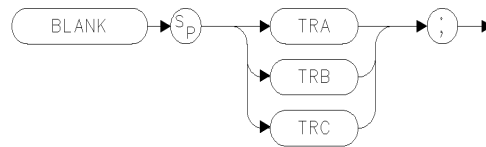

XBLANK .

Preset State: BLANK TRB, BLANK TRC

NOTE

TRA corresponds to Trace 1, TRB corresponds to Trace 2, and TRC corresponds to Trace 3.

BML **Trace B Minus Display Line**

Subtracts display line from trace B and places the result in trace B.

Syntax



XBML

Description

The BML command subtracts the display line from trace B (point by point), and sends the difference to trace B.

NOTE Trace B corresponds to Trace 2.

CAL Calibration

Initiates self-calibration routines.

Syntax

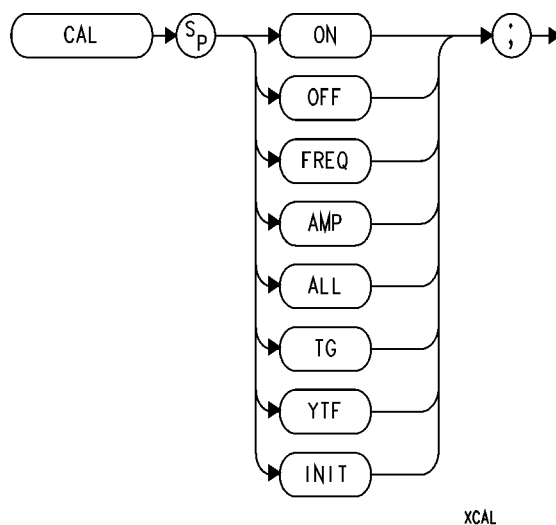

Description

The CAL command controls calibration functions. CAL initiates action according to the CAL parameters. The various parameters correspond to spectrum analyzer softkeys as shown below:

ON turns the frequency correction on and corresponds to **System, Alignments, Freq Correct On Off** (On is underlined). (See also “CORREK.”)

OFF turns the frequency correction off and corresponds to **System, Alignments, Freq Correct On Off** (Off is underlined). (See also “CORREK.”)

NOTE

For all models except E4401B and E4411B, connect a cable between AMPTD REF OUT and the spectrum analyzer input before running the CAL FREQ, CAL AMP, CAL YTF, or CAL ALL correction routines.

FREQ initiates the Align Now All routine and corresponds to **System, Alignments, Align Now, All**.

AMP initiates the Align Now All routine and corresponds to **System, Alignments, Align Now, All**.

YTF initiates the correction routine for the RF section only. The YTF command corresponds to **System, Alignments, Align Now, RF (Ext Cable)**.

ALL initiates the Align Now All routine and corresponds to **System, Alignments, Align Now, All**.

INIT sets the calibration data back to predetermined values. CAL INIT corresponds to **System, Alignments, Load Defaults**.

NOTE Before executing the CAL TG command, a cable must be connected between the tracking generator output and the spectrum analyzer input.

TG performs the calibration routines if the tracking generator is installed (Option 1DN) on all models except E4401B and E4411B. CAL TG corresponds to **System, Alignments, Align Now, TG (Ext Cable)**.

The take sweep (TS) and DONE commands can be used to indicate that the correction routine has finished.

Differences

8590 Series: CAL ALL initiates frequency and amplitude correction routines. CAL FREQ and CAL AMP perform only frequency or amplitude correction routines, respectively. CAL ON or OFF enables or disables the correction factors. CAL YTF initiates the correction routine for the YIG-tuned filter.

ESA Option 290: CAL ALL, CAL FREQ, and CAL AMP are equivalent and perform an alignment of all assemblies except the tracking generator (if installed). CAL ON or OFF toggles the state of the frequency corrections. CAL YTF aligns the RF section of the analyzer.

CF Center Frequency

Specifies the center frequency.

Syntax

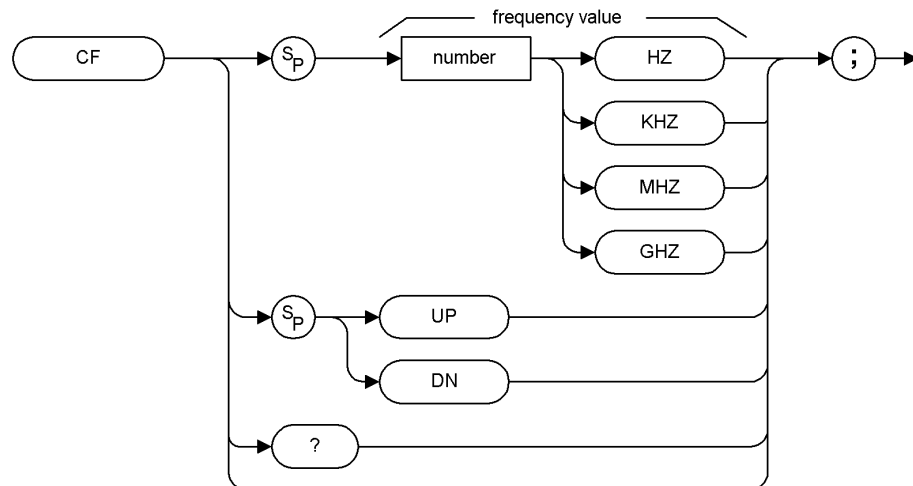

XCF

Item	Description/Default	Range
Number	Any real or integer number. Default unit is Hz.	Frequency range of the spectrum analyzer

Step Increment: If uncoupled, step size is determined by the SS command. If coupled, step size is 10% of span.

NOTE

Although the spectrum analyzer allows entry of frequencies not in the specified frequency range, using frequencies outside the frequency span of the spectrum analyzer is not recommended and is not warranted to meet specifications.

Description

The CF command specifies the value of the center frequency.

Query Response

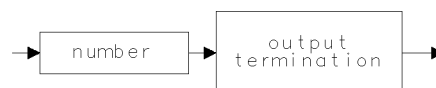

QQ1

CLRAVG Clear Average

Restarts video averaging.

Syntax

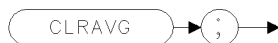

XCLRAVG .

Description

The CLRAVG command restarts the VAVG command by resetting the number of averaged sweeps to one. The video averaging routine resets the number of sweeps, but does not stop video averaging. Use “VAVG OFF;” to stop video averaging.

CLRW Clear Write

Clears the specified trace and enables trace data acquisition.

Syntax

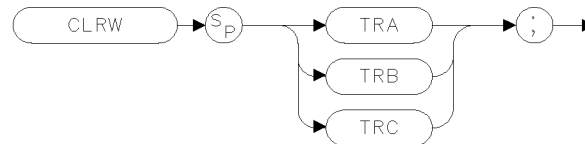

YCLP

Preset State: CLRW TRA

Description

The CLRW command places the indicated trace in the clear-write mode. Data acquisition begins at the next sweep. (See “TS” for more information about data acquisition.)

NOTE

TRA corresponds to Trace 1, TRB corresponds to Trace 2, and TRC corresponds to Trace 3.

CLS Clear Status Byte

Clears all status bits.

Syntax



XCLS

Description

The CLS command clears all the status bits in the status byte.

CONTS Continuous Sweep

Sets the spectrum analyzer to the continuous sweep mode.

Syntax



XCONTS . . .

Preset State: CONTS

Description

The CONTS command sets the spectrum analyzer to continuous sweep mode. In the continuous sweep mode, the spectrum analyzer takes its next sweep as soon as possible after the current sweep (as long as the trigger conditions are met). A sweep may temporarily be interrupted by data entries made from the front panel or over the remote interface.

CORREK Correction Factors On

Returns a “1” if the frequency correction factors are on, a “0” if they are off.

Syntax

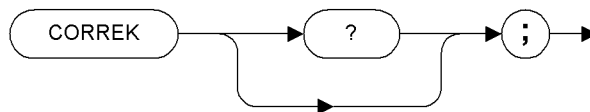

XCORREK

Query Response

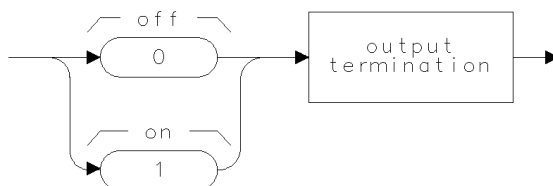

Differences

8590 Series: Queries the state of the correction factors.

ESA Option 290: Queries the state of the frequency corrections.

COUPLE Couple

Selects direct-current (dc) coupling or alternating-current (ac) coupling.
 For 8594E, 8595E, or 8596E compatibility only.

Syntax

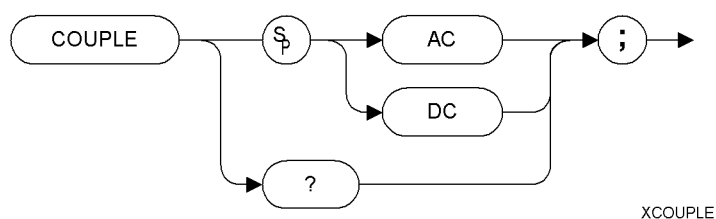

Model Required: E4404B, E4405B, E4402B Option UKB, or E4407B Option UKB.

Preset State: AC

Description

CAUTION

Do not use dc coupling if there is **any** dc voltage at the spectrum analyzer input. Do not exceed the power stated on the spectrum analyzer input. See the specifications for your spectrum analyzer for more information.

If there is no dc voltage at the spectrum analyzer input, dc coupling is useful for observing low frequency signals at the spectrum analyzer input. Use ac coupling when there is dc voltage at the spectrum analyzer input (ac coupling blocks the dc voltage and allows only the ac voltage to pass).

Query Response

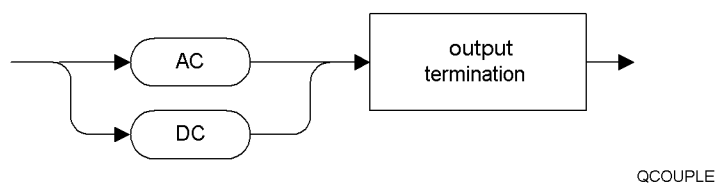

DET Detection Mode

Selects the spectrum analyzer detection mode.

Syntax

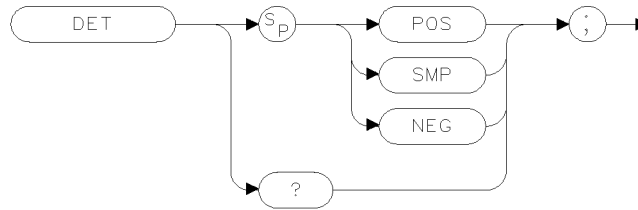

XDET

Preset State: DET POS

Description

The DET command selects the type of spectrum analyzer detection (positive-peak, sample, or negative) and accesses service-diagnostic detection functions.

POS enables positive-peak detection, which displays the maximum video signal detected over a number of instantaneous samples for a particular frequency.

SMP enables sample detection, which uses the instantaneous video signal value. Video averaging and noise-level markers, when activated, activate sample detection automatically.

NEG enables negative peak detection in sweep times of less than or equal to 200 ms.

Query Response

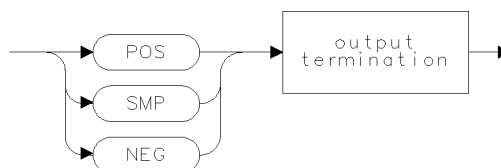

QDET

DL Display Line

Defines the level of the display line in the active amplitude units and displays the display line on the spectrum analyzer screen.

Syntax

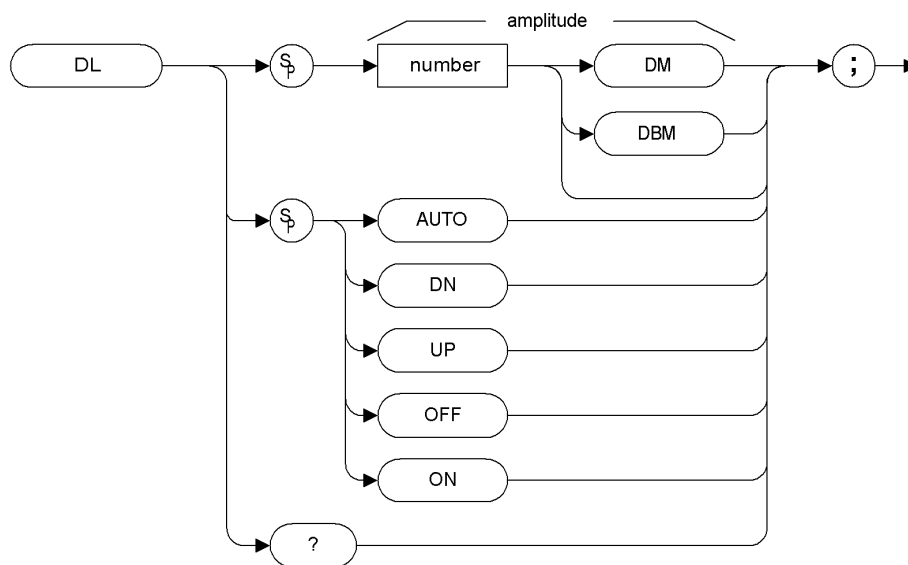

XDL

Item	Description/Default	Range
Number	Any real or integer number. Default units are dBm.	Dependent on the reference level

Preset State: DL OFF

Step Increment: 1 major division

Description

Activating video trigger mode activates the display line. The AUTO command and “DL OFF;” turn off the display line. See “AUNITS” for more information on changing the active amplitude units.

Query Response

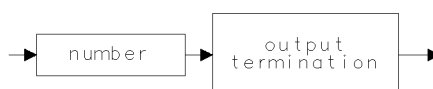

QQ1

DN Down

Reduces the current function by the applicable step size.

Syntax



XDN

Description

Before executing DN, be sure that the command for the desired function to be decreased has been sent.

The functions affected by DN are AT, CF, DL, FA, FB, LG, MKD, MKFCR, MKN, MKPX, ML, RB, RL, ROFFSET, SP, SRCAT, SRCPOFS, SRCPSWP, SRCPWR, SRCTK, SS, ST, VB, and VBR.

Differences

8590 Series: As a stand-alone command, affects the parameter whose active function is enabled.

ESA Option 290: As a stand-alone command, affects the last relevant parameter whose remote command was sent.

DONE

Done

Allows you to determine when the spectrum analyzer has parsed the spectrum analyzer commands and has started to execute all commands prior to and including DONE. The spectrum analyzer returns a value of "1" when all commands in a command string entered before DONE have been started.

Syntax

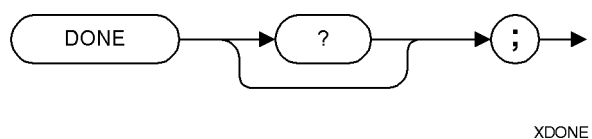

Description

If a take sweep (TS) precedes the DONE command, DONE is executed after all the preceding commands have been completed. Use a take sweep (TS) to ensure all previous commands have completed before DONE returns a "1."

Query Response



FA Start Frequency

Specifies the start frequency.

Syntax

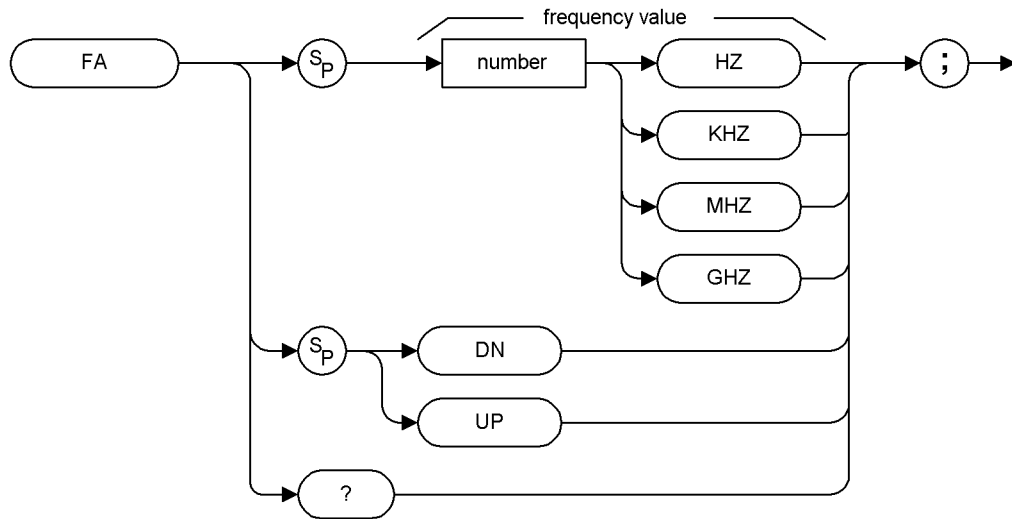

XFA

Item	Description/Default	Range
Number	Any real or integer number. Default unit is Hz.	Frequency range of the spectrum analyzer

Step Increment: Frequency span divided by 10

Description

The FA command specifies the start frequency value. The start frequency is equal to the center frequency minus the span divided by two ($FA = CF - SP/2$). Changing the start frequency changes the center frequency and span.

Query Response

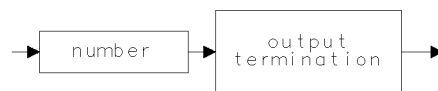

QQ1

FB Stop Frequency

Specifies the stop frequency.

Syntax

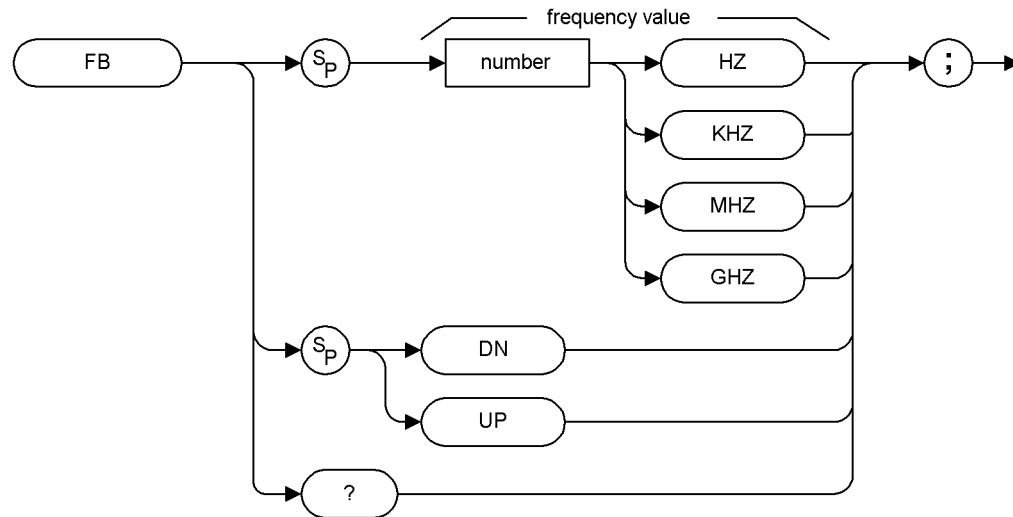

XFB

Item	Description/Default	Range
Number	Any real or integer number. Default unit is Hz.	Frequency range of the spectrum analyzer

Step Increment: Frequency span divided by 10

Description

The FB command specifies the stop frequency value. The stop frequency is equal to the center frequency plus the span divided by two ($FB = CF + SP/2$). Changing the stop frequency changes the center frequency and span.

Query Response

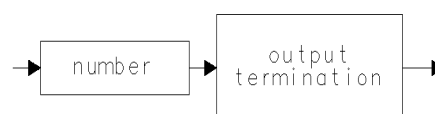

QQ1

FOFFSET Frequency Offset

Specifies the frequency offset for all absolute frequency readouts such as center frequency.

Syntax

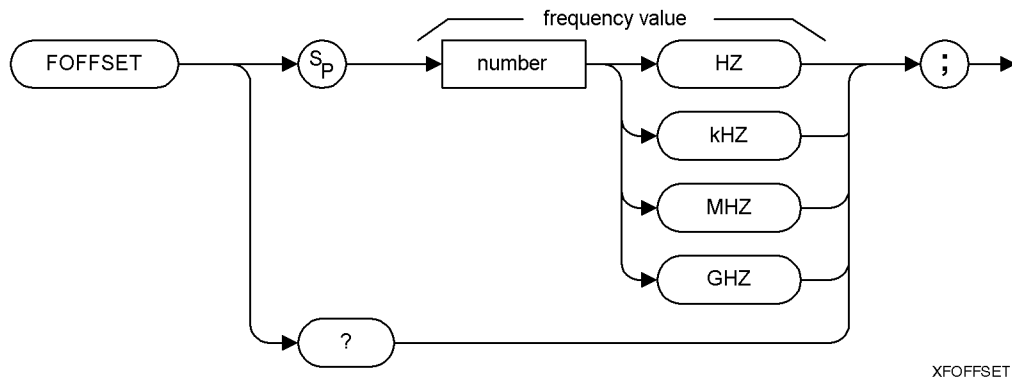

Item	Description/Default	Range
Number	Any real or integer number. Default unit is Hz.	

Preset State: 0 Hz

Description

The FOFFSET command selects a value that offsets the frequency scale for all absolute frequency readouts (for example, center frequency). Relative values such as span and marker delta are not offset.

When an offset is in effect, it is displayed beneath the bottom graticule line on the spectrum analyzer screen.

Execute “FOFFSET 0;” or “IP;” to turn off the offset.

Query Response

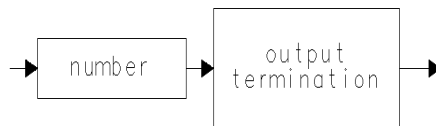

QQ1

FS Full Span

Sets the frequency span of the spectrum analyzer to full span.

Syntax



XFS

Description

The FS command selects both the start frequency and the stop frequency according to the frequency span of the spectrum analyzer. Resolution bandwidth, video bandwidth, and sweep time are all set to auto-coupled.

Spectrum Analyzer Model	Start Frequency	Stop Frequency
E4401B	0 Hz	1.5 GHz
E4402B	0 Hz	3.0 GHz
E4403B	0 Hz	3.0 GHz
E4404B	0 Hz	6.7 GHz
E4405B	0 Hz	13.2 GHz
E4407B	0 Hz	26.5 GHz
E4408B	0 Hz	26.5 GHz
E4411B	0 Hz	1.5 GHz

GRAT Graticule

Turns on or off the graticule.

Syntax

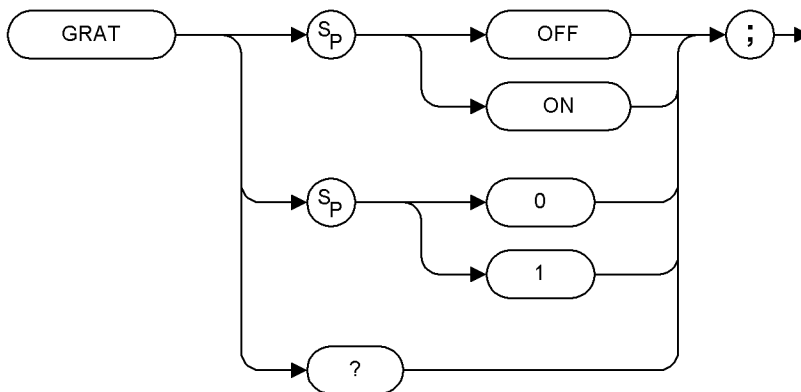

XGRAT

Preset State: GRAT ON

Query Response

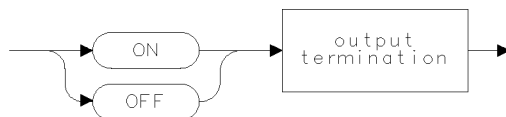

QQ2

ID Identify

Returns the spectrum analyzer model number to the controller (for example, “HP 8591E”).

Syntax

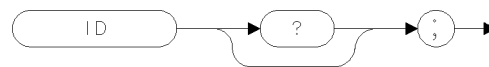

XID

Query Response

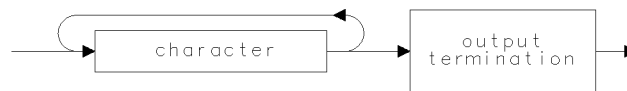

QID

NOTE

The response value is configured via the front-panel menu selection for remote ID. See [“Uninstalling/Installing Option 290” on page 10](#) for details.

IP Instrument Preset

Performs an instrument preset.

Syntax



XIP

Description

The instrument preset command, IP, executes the following commands:

ANNOT	Turns on annotation.
AT	Couples the attenuation to the reference level.
AUNITS	Loads the amplitude units from a configuration location in spectrum analyzer memory.
BLANK 2, BLANK 3	Blanks Trace 2 and Trace 3.
CLRW 1	Clears and writes Trace 1.
CONTS	Selects continuous sweep mode.
DET	Selects positive peak detection.
DL	Turns off the display line.
FOFFSET	Sets the frequency offset to 0 Hz.
GRAT	Turns on the graticule.
LG	Selects 10 dB per division log scale.
MDS	Selects data size of one word, which is two 8-bit bytes.
MKFCR	Marker counter resolution is set to AUTO, but a calculated value other than 0 may be returned if the marker counter resolution is queried.
MKNOISE	Turns off noise markers.
MKOFF	Turns off all markers.
MKPX	Minimum excursion for peak identification is set to 6 dB.
MKREAD	Sets marker readouts to frequency.

MKTRACK	Turns off signal track.
ML	Sets mixer level to –10 dBm.
RB	Couples the resolution bandwidth to the frequency span.
RL	Sets reference level to 0 dBm.
ROFFSET	Sets reference offset to 0.
SRCPSWP	Sets the source power sweep to off (Option 1DN or 1DQ only).
SRCPWR	Sets the source power level to –10 dBm (Option 1DN or 1DQ only).
SS	Couples the center frequency step size to the span.
TDF	Selects parameter units output format.
TM	Selects free run trigger mode.
TRC	Sets the trace values to the top graticule line.
VAVG	Turns off video averaging and sets the video averaging limit to 100.
VB	Couples the video bandwidth to the resolution bandwidth.
VBR	Sets VBR to 1.00.

Instrument preset automatically occurs when you turn on the spectrum analyzer. IP is a good starting point for many measurement processes. When IP is executed remotely, the spectrum analyzer does not necessarily execute a complete sweep, however. You should execute a take sweep (TS) to ensure that the trace data is valid after an IP.

LF Low Frequency Preset

Performs an instrument preset to the base band (band 0). For 8592L, 8593E, 8595E, or 8596E compatibility only.

Syntax



XLF

Description

Use LF instead of instrument preset (IP) if harmonic band 0 is desired.

LG Logarithmic Scale

Specifies the vertical graticule divisions as logarithmic units, without changing the reference level.

Syntax

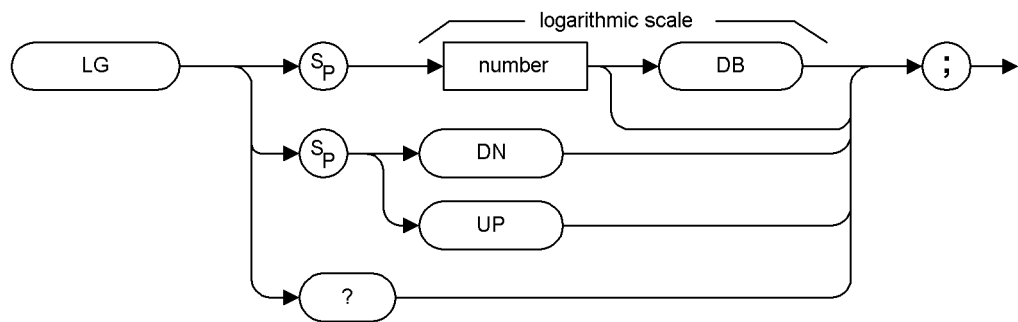

XLG

Item	Description/Default	Range
Number	Any real or integer number. Default units are dB.	0.1 to 20 dB.

Preset State: 10 dB

Description

The vertical scale can be specified (in tenths) from 0.1 to 0.9 dB, or in integers from 1 to 20 dB per graticule division.

Query Response

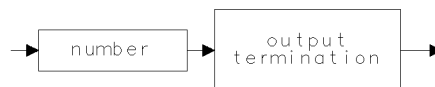

QQ1

LN Linear Scale

Specifies the vertical graticule divisions as linear units, without changing the reference level.

Syntax



XLN

Description

The LN command scales the amplitude (vertical graticule divisions) proportionally to the input voltage, without changing the reference level. The bottom graticule line represents a signal level of zero volts.

Voltage entries are rounded to the nearest 0.1 dB. Thus, 30.16 mV becomes -17.4 dBm for a 50Ω spectrum analyzer system.

LSPAN Last Span

Changes the spectrum analyzer's span to the previous span setting.

Syntax



XLSPAN .

MDS Measurement Data Size

Specifies measurement data size as byte or word when the trace data format mode is B, A, or I. See the TDF command for more information.

Syntax

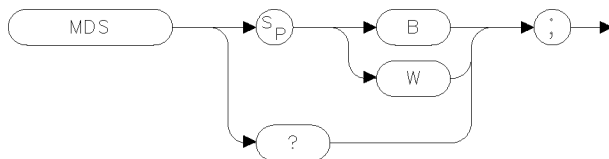

XMDS

Description

The MDS command formats binary data in one of the following formats:

B selects a data size of one 8-bit byte. When transferring trace data, MDS B transfers trace data the faster than MDS W because only 401 bytes are transferred. Because MDS B combines two bytes into one byte, some resolution is lost.

W selects a data size of one word, which is two 8-bit bytes. When transferring trace data, MDS W transfers 802 bytes of trace data with no loss of resolution.

How data is represented with MDS W: When data is sent with MDS W, the trace data is converted into two bytes as follows:

1. The trace element's amplitude (in measurement units) is divided by 256. The binary representation of the result is placed in the most significant byte (MSB).
2. The binary representation of the remainder is placed in the least significant byte (LSB).

For example, a trace element that is at the reference level has the value of 8000 (in measurement units). The result of 8000 divided by 256 is 30, with a remainder of 120. For this data, the contents of the MSB would contain the binary representation for 30.

0	0	0	1	1	1	1	0
---	---	---	---	---	---	---	---

For this data, the contents of the LSB would contain the binary representation for 120.

0	1	1	1	1	0	0	0
---	---	---	---	---	---	---	---

How data is represented with MDS B: When data is sent with MDS B, the trace data is converted into one byte as follows:

The trace element's amplitude (in measurement units) is divided by 32. The binary representation of the result is placed into one byte.

For example, a trace element that is at the reference level has the value of 8000 (in measurement units). The result of 8000 divided by 32 is 250. For this data, the contents of the byte would contain the binary representation for 250.

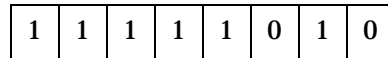

See "TDF" for information about using MDS for trace data transfers.

Query Response:

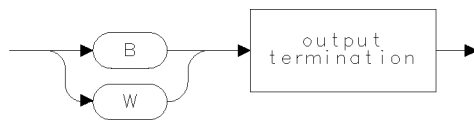

QMDS

MEAN Trace Mean

Returns the mean value of the given trace in measurement units.

Syntax

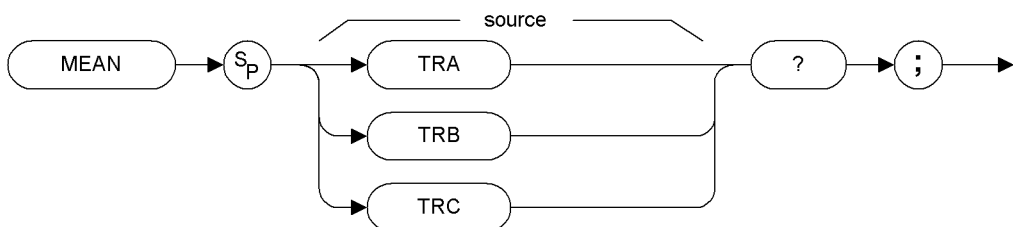

Prerequisite Commands: TS when using trace data

Query Response

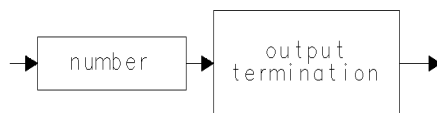

QQ1

NOTE

TRA corresponds to Trace 1, TRB corresponds to Trace 2, and TRC corresponds to Trace 3.

MF Marker Frequency Output

Returns the frequency (or time) of the on-screen active marker.

Syntax

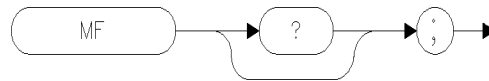

Description

The MF command returns the frequency of the active marker to the controller if the marker is on screen. In delta marker mode, nonzero span, “MF;” returns the frequency difference between the two markers. In zero span, “MF;” returns the marker time, or the delta marker time.

The data that is returned by “MF;” depends on many command conditions including TDF, MKREAD, and MDS.

If the trace data format P is used with MF, the result is one real value in time units or frequency units, depending on the marker readout format. (See “MKREAD.”)

MINH Minimum Hold

Updates trace C with the minimum level detected.

Syntax



XMINH

Description

MINH updates trace C with a new value from a detector only if the new value is smaller than the previous trace data value.

NOTE

Trace C or TRC corresponds to Trace 3.

MKA Marker Amplitude

Returns the marker amplitude, independent of marker type.

Syntax

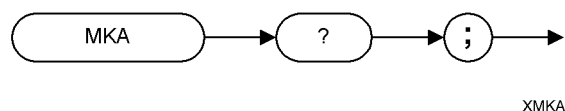

Description

If both the delta marker and active marker are on the screen, “MKA?;” returns the amplitude difference between the two markers. If the trace data format P (TDF P), is used with MKA, the result is one real value in the current amplitude units (AUNITS can be used to change the current amplitude units).

Query Response

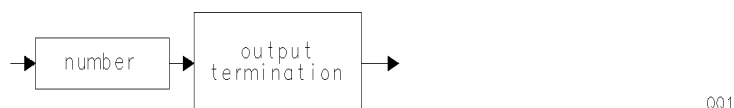

Differences

8590 Series: MKA can be used with a numeric argument that places the marker at that specified amplitude on the screen.

ESA Option 290: MKA is a query-only command. It will not accept arguments of any type.

MKACT Activate Marker

Specifies the active marker.

Syntax

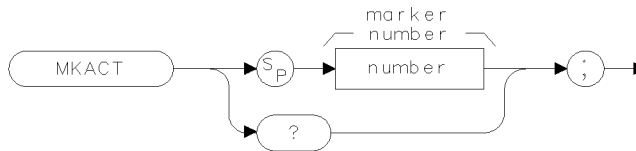

XMKA

Item	Description/Default	Range
Number	Any valid integer. Default value is 1.	1 to 4

Description

There can be four different markers, but only one marker can be active at any time.

When this command is used, the following results occur:

The marker number supplied by the command is made the active marker.

If the marker number is not already on, the marker is turned on with preset type (position), and the marker is placed at center screen. The trace chosen is the first displayed trace found: Trace 1, trace 2, trace 3.

NOTE

If the MKACT command is used to return to a marker that was already active, but was a different marker type, it replaces that marker with the new marker function. The amplitude and frequency for the previous marker are not saved.

Query Response

"MKACT?;" returns the marker number.

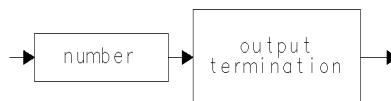

001

MKCF Marker to Center Frequency

Sets the center frequency equal to the marker frequency and moves the marker to the center of the screen.

Syntax



XMKCF

Description

This command is performed only if an active marker is present on screen.

MKD Marker Delta

Activates the delta marker.

Syntax

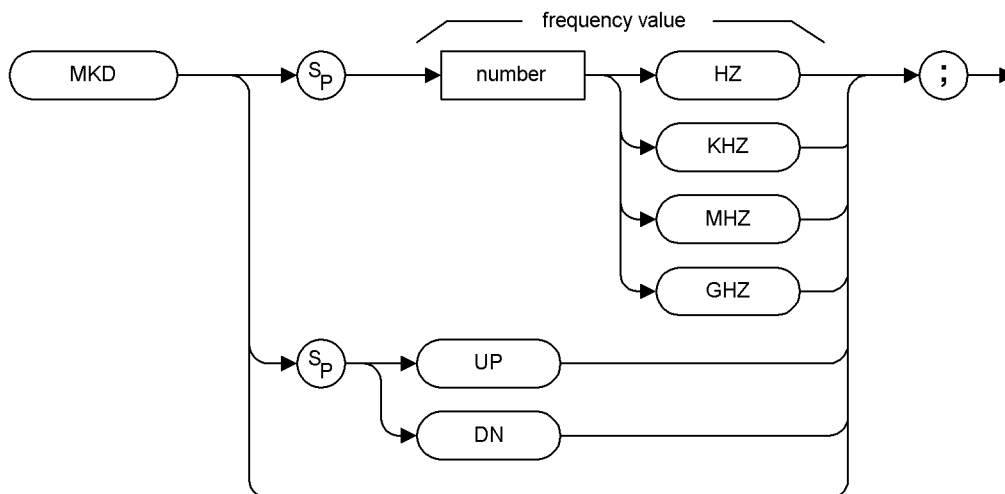

XMKD

Item	Description/Default	Range
Number	Any real or integer number. Default unit is Hz, default value is value of the active marker.	Start frequency to stop frequency of spectrum analyzer

Step Increment: by 1/10 of the frequency span

Description

The MKD command computes the frequency and amplitude difference of the active marker and a special marker, called the delta or differential marker. These values are displayed in the display readout.

The differential value of the frequency is equal to the active marker frequency minus the delta marker frequency. The differential value of the amplitude is equal to the active marker amplitude minus the delta marker amplitude.

If an active marker is not on the screen, MKD positions an active marker at center screen. If a delta marker is not on the screen, MKD places one at the specified frequency, or at the current active marker. If the active marker is in amplitude mode, the delta marker is placed at the same amplitude as the active marker (or a specified value).

To read the amplitude, use MKA?. To read the frequency, use MKF?. The results are displayed on the spectrum analyzer screen.

In linear mode, MKD computes the ratio of the amplitudes of the active and delta markers rather than the difference. This results in similar treatment for logarithmic and linear data because the delta (or, the difference) of two logarithmically generated numbers is the logarithm of the linear ratio of the two numbers. You should not change reference level when making a marker delta measurement, however.

If the marker delta function is on, the noise marker can be activated (MKNOISE) and moved to measure the noise floor. The marker readout will then display the signal-to-noise ratio.

MKF Marker Frequency

Returns the frequency value of the active marker.

Syntax

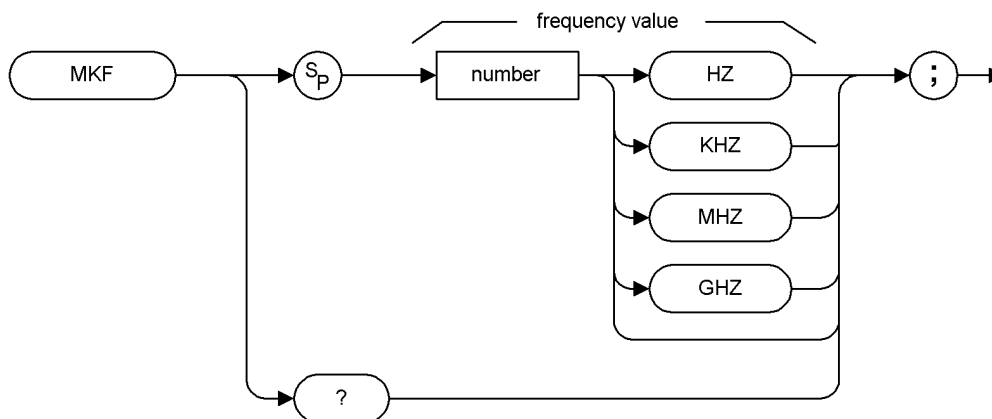

XMKF

Item	Description/Default	Range
Number	Any real or integer number. Default unit is Hz.	Start frequency to stop frequency of spectrum analyzer

Description

In nonzero frequency spans, MKF returns the active marker frequency as a real number when MKF is queried. In zero span, “MKF?;” returns the time value.

The data that is returned by MKF depends on many command conditions, including TDF, MKREAD, and MDS.

MKF results with TDF set to P: If the trace data format P is used with MKF, the result is one real value in time units or frequency units, depending on MKREAD.

MKF results with TDF set to A or I: If the trace data format is used with trace data format A, the result depends on the setting of the MDS command.

Using the trace data format I is equivalent to the TDF A format.

MKF results with TDF set to M: If the trace data format is used with trace data format M, the result is the marker horizontal position value, from 1 to 401, in ASCII.

Query Response

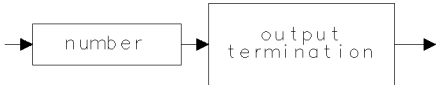

QQ1

MKFC Marker Counter

Turns on or off the marker frequency counter.

Syntax

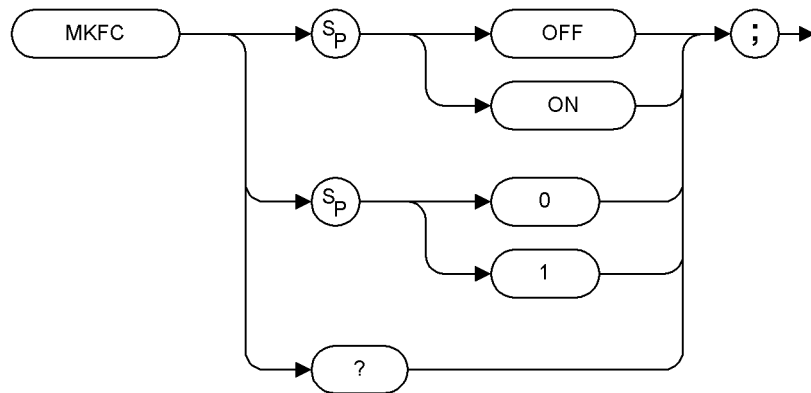

XMKFC

MKFCR Marker Counter Resolution

Sets the resolution of the marker frequency counter.

Syntax

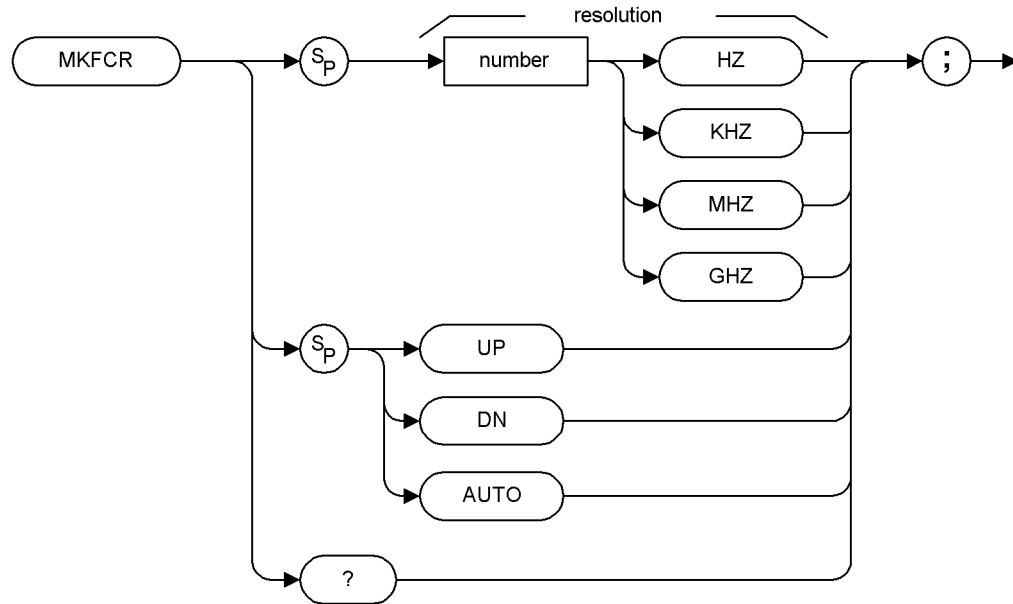

XMKFCR

Item	Description/Default	Range
Number	Any real or integer number (powers of 10 only). Default unit is Hz.	1 kHz to 100 kHz

Preset State: Marker counter resolution is set to AUTO. The calculated value for the marker counter resolution is returned if the MKFCR is queried.

Description

Executing either “MKFCR 0;” or “MKFCR AUTO;” auto-couples the marker counter resolution to the frequency span.

Query Response

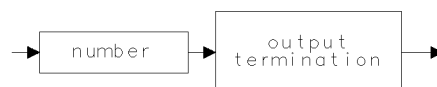

QQ1

MKMIN Marker Minimum

Moves the active marker to the minimum value detected.

Syntax



XMKMIN .

MKN Marker Normal

Activates and moves the marker to the specified frequency.

Syntax

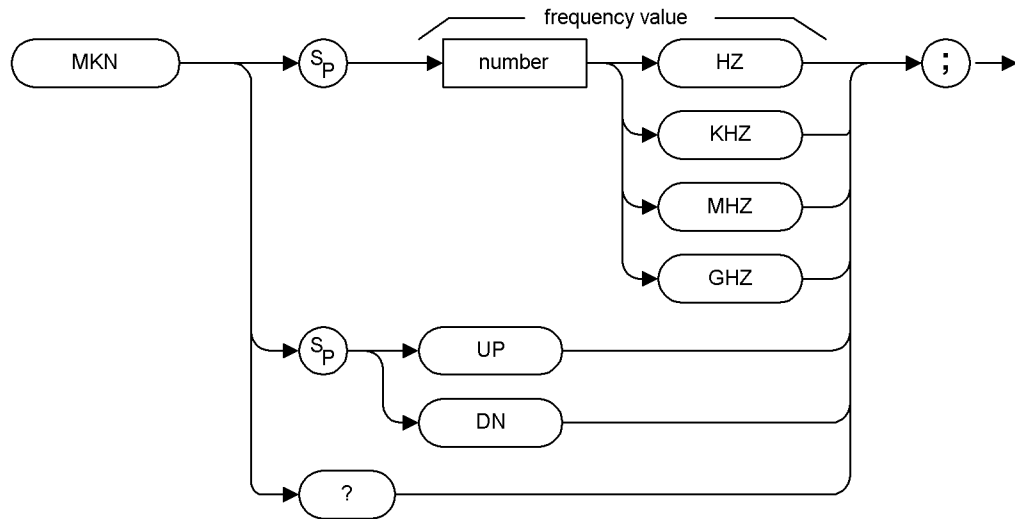

XMKN

Item	Description/Default	Range
Number	Any real or integer number. Default unit is Hz. Default value is the center frequency of the spectrum analyzer.	Start frequency to stop frequency of spectrum analyzer

Step Increment: by 1/10 of the frequency span.

Description

In nonzero span, “MKN?;” returns the frequency value. In zero span, “MKN?;” returns the time value.

Query Response

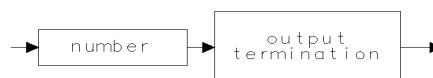

QQ1

MKNOISE Marker Noise

Displays the average noise level at the marker.

Syntax

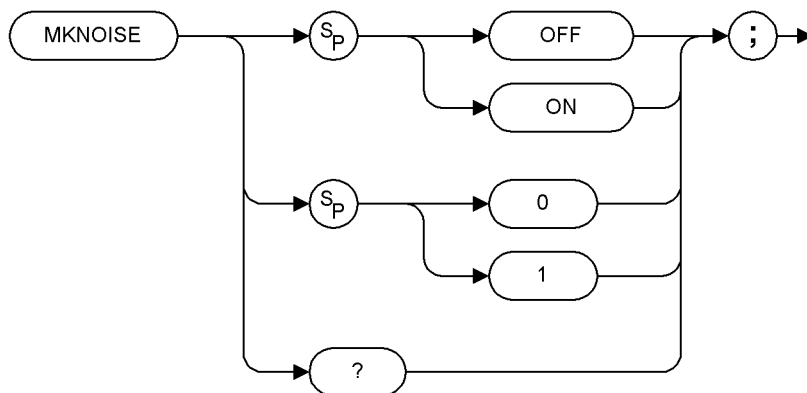

XMKNOISE

Description

The marker value is normalized to a 1 Hz bandwidth. Use “MKA?;” to read the noise marker value. If the marker delta function is on and the noise marker is activated and moved to measure the noise floor, the marker readout will display the signal-to-noise ratio.

The noise marker averages 32 trace data values about the location of the marker on the frequency or time scale. The 32 values averaged, except for the first 15 or last 14 values in the trace, commence with the 16th point to the left of the marker, and end with the 15th point to the right of the marker. Note that the data values averaged are not exactly symmetrical with respect to marker position. At the trace end points, the spectrum analyzer uses the nearest 32 data values. So while the marker may be moved to trace position 1 to 15, the actual amplitude value returned will be the same value for any marker position from 1 to 15. A similar situation applies for markers at the end of the trace.

A nominal correction for equivalent noise bandwidths is made by the firmware based on a nominal 3 dB resolution bandwidth. The firmware assumes the noise bandwidth is 1.12 times the resolution bandwidth. This means the shape of the resolution bandwidth filters cause the noise power to be overstated by 1.12 times. The detection mode also affects the measurement. If in log mode, the log detector understates the noise response. To compensate, 2.5 dB is added to the measurement. If the detector is in linear mode, the firmware uses 1.05 dB as a correction value.

In log detector mode, the final reported value will then be, with the result reported in dBm in a 1 Hz bandwidth:

$$(\text{Averaged value over 32 values}) - 10 \times (\log[1.12 \times \text{Resolution bandwidth}]) + 2.5 \text{ dB}$$

In linear detector mode (dBm) units, the final reported value will then be, with the result reported in dBm in a 1-Hz bandwidth:

$$(\text{Averaged value over 32 values}) - 10 \times (\log[1.12 \times \text{Resolution bandwidth}]) + 1.05 \text{ dB}$$

In linear detector mode with the normal display of voltage units, the noise marker voltage value will be related to the present marker voltage by this relation.

$$(V_{\text{noise_marker}})^2 = (V_{\text{average}})^2 \times 1.12 \times \text{Resolution bandwidth} \times 0.7824$$

$$V_{\text{noise_marker}} = V_{\text{average}} / (1.12 \times \text{Resolution bandwidth} \times 0.7824)^{0.5}$$

$$V_{\text{noise_marker}} = V_{\text{average}} \times 1.06633 / (\text{Resolution bandwidth})^{0.5}$$

Query Response

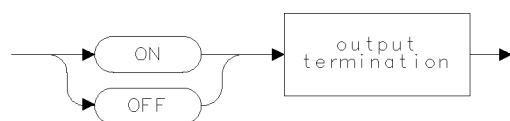

002

MKOFF Marker Off

Turns off either the active marker or all the markers.

Syntax

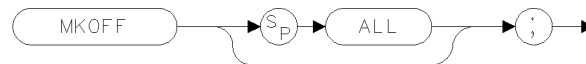

XMKC

Description

If the ALL parameter is omitted, only the active marker is turned off.

MKP Marker Position

Places the active marker at the given x -coordinate.

Syntax

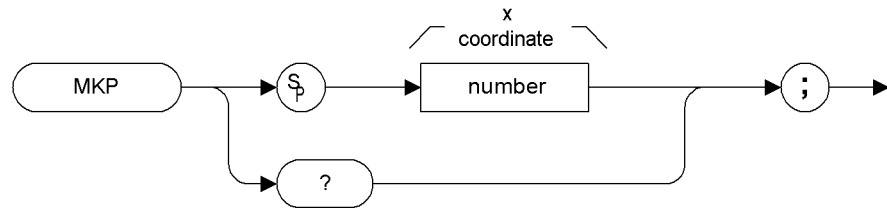

XMKP

Item	Description/Default	Range
Number	Any valid integer	-401 to 401

Description

If no marker is active, the marker is turned on with preset type (position) and marker is placed at the given screen position. The marker is placed on the first displayed trace that is found (in order): trace 1, trace 2, or trace 3.

If the marker delta mode is active, the value of the marker position is relative to the fixed marker, and therefore MKP can return a negative position.

Note that MKP and MKCF commands perform different functions. MKCF sets the center frequency equal to the marker frequency and moves the marker to the center of the screen. MKP places the marker to the position of the element specified.

Query Response

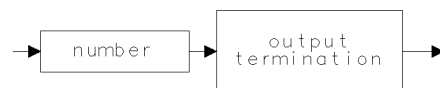

QQ1

MKPK Marker Peak

Positions the active marker on a signal peak.

Syntax

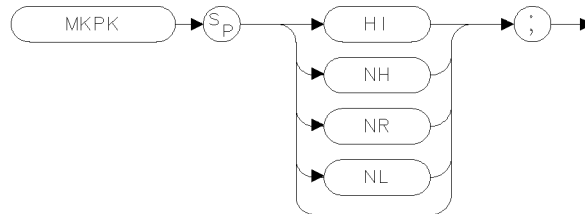

XMKPK

Description

Executing MKPK HI, or simply MKPK, positions the active marker at the highest signal detected. If an active marker is on the screen, the MKPK parameters move the marker as follows:

HI (highest) moves the active marker to the highest peak.

NH (next highest) moves the active marker to the next signal peak of lower amplitude.

NR (next right) moves the active marker to the next signal peak of higher frequency.

NL (next left) moves the active marker to the next signal peak of lower frequency.

NOTE This function is for use with the frequency markers only.

Differences

8590 Series: MKPK can be used to “Marker Peak” to the LO feedthrough (0 Hz).

ESA Option 290: MKPK cannot be used to “Marker Peak” to the LO feedthrough.

MKPX Marker Peak Excursion

Specifies the minimum signal excursion for the spectrum analyzer's internal peak identification routine.

Syntax

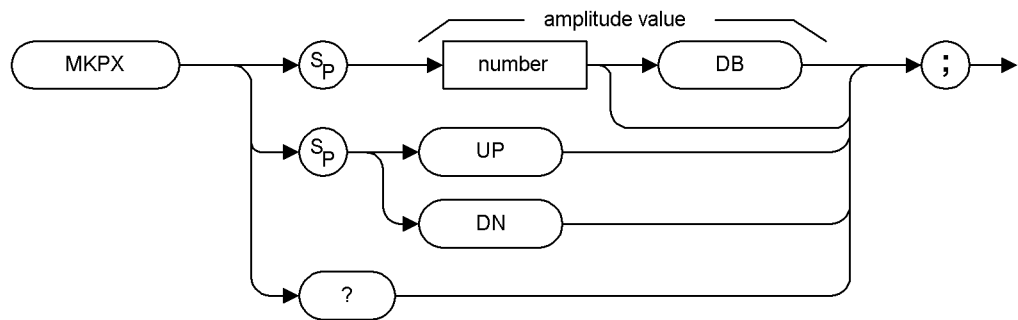

XMKPX

Item	Description/Default	Range
Number	Any real or integer number. Default unit is dB.	0 to 100 dB

Preset State: 6 dB.

Step Increment: by 1 dB.

Query Response

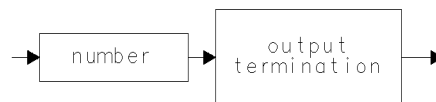

QQ1

MKREAD Marker Readout

Selects the type of active trace information displayed by the spectrum analyzer marker readout.

Syntax

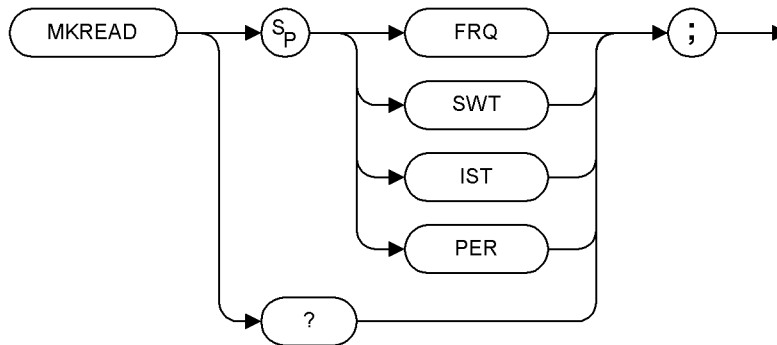

XMKREAD

Description

The MKREAD command can select the following types of active trace information:

- FRQ** frequency
- SWT** sweep time
- IST** inverse sweep time
- PER** period

The results of the data depend on the MKREAD parameter, the frequency span, and if the marker delta function is used.

MKREAD Type	Non-Zero Span	Non-Zero Span Delta	Zero Span	Zero Span Delta
FRQ	Reads frequency	Reads delta frequency	N/A	N/A
SWT	Reads time since the start of sweep	Reads delta time between end points	Waveform measurements of detected modulation	Waveform measurements of detected modulation

MKREAD Type	Non-Zero Span	Non-Zero Span Delta	Zero Span	Zero Span Delta
IST	N/A	N/A	N/A	Computes frequency corresponding to delta of markers. Performs $1 / (T_1 - T_2)$
PER	Period of frequency	(Pulse measurement) delta time	N/A	N/A

Query Response

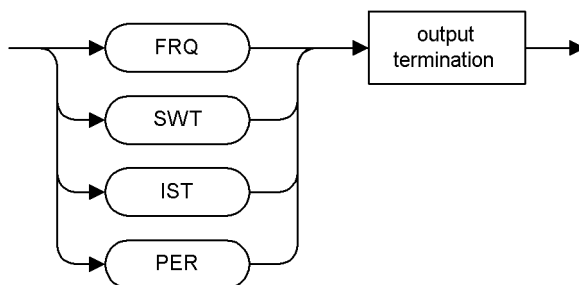

QMKREAD

MKRL Marker to Reference Level

Sets the reference level to the amplitude value of the active marker.

Syntax



XMKRL

MKSP Marker to Span

Sets the start and stop frequencies to the values of the delta markers.

Syntax



XMKSP

Description

The left marker specifies start frequency, and the right marker specifies stop frequency. If MKD is off, no operation is performed.

MKSS Marker to Step Size

Sets the center-frequency step-size to the marker frequency.

Syntax



XMKSS

Description

Sets the center-frequency step-size equal to the marker frequency. If in the delta mode, the step size is set to the delta frequency (absolute value).

MKTRACE Marker Trace

Moves the active marker to a corresponding position in Trace 1, trace 2, or trace 3.

Syntax

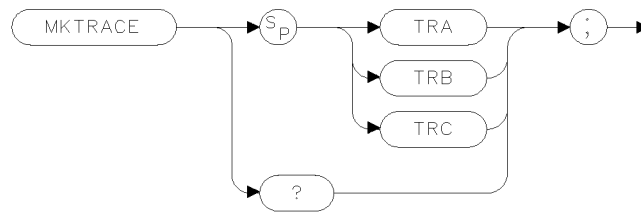

XMKTRAC

Query Response

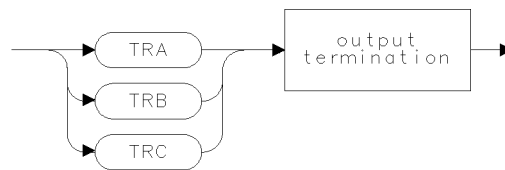

QMKTRACE

NOTE TRA corresponds to Trace 1, TRB corresponds to Trace 2, and TRC corresponds to Trace 3.

MKTRACK Marker Track

Moves the signal on which the active marker is located, to the center of the spectrum analyzer display and keeps the signal peak at center screen.

Syntax

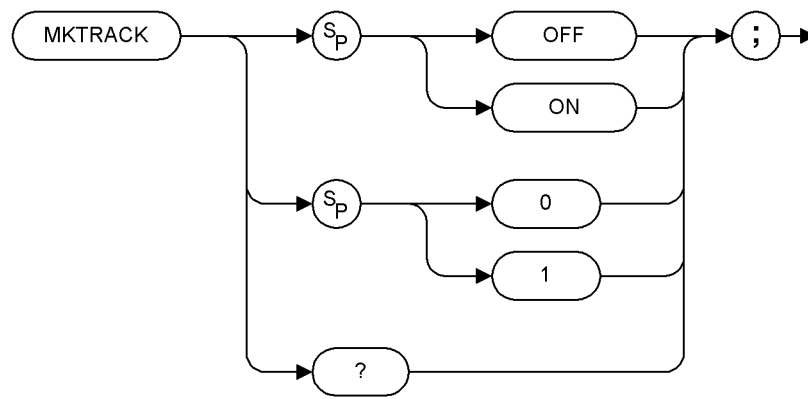

XMKTRACK

Description

To keep a drifting signal at center screen, place the active marker on the desired signal before turning on MKTRACK.

Query Response

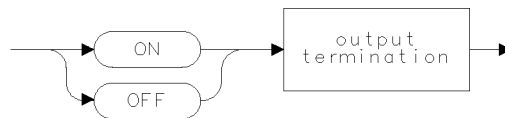

QQ2

ML Mixer Level

Specifies the maximum signal level that is applied to the input mixer for a signal that is equal to or below the reference level.

Syntax

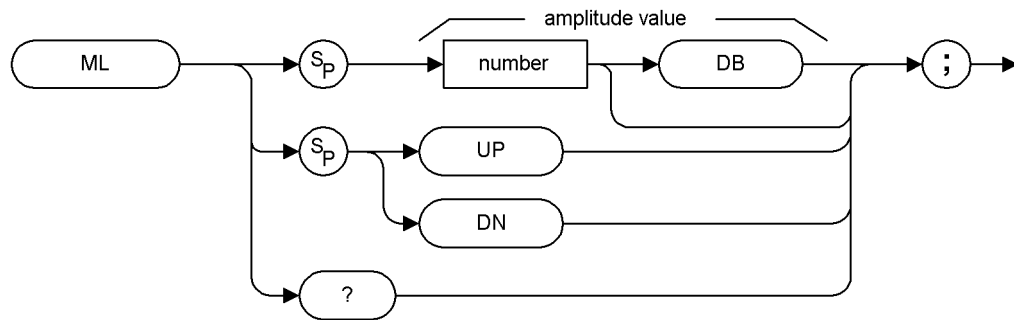

XML

Item	Description/Default	Range
Number	Any real or integer number. Default unit is dBm.	+10 to -100 dBm

Preset State: -10 dBm.

Step Increment: 10 dB minimum.

Description

The ML command specifies the maximum signal level that is applied to the input mixer for a signal that is equal to or below the reference level.

The effective mixer level is equal to the reference level minus the input attenuator setting. When ML is activated, the effective mixer level can be set from +10 dBm to -100 dBm in 1 dB steps.

Query Response

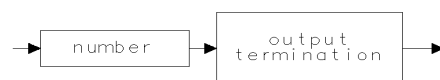

QQ1

MXMH Maximum Hold

Updates each trace element with the maximum level detected.

Syntax

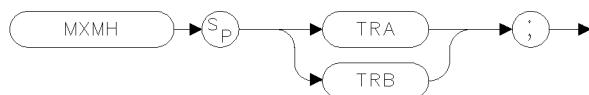

MXMH

Description

MXMH updates the specified trace (either Trace 1 or trace 2) with a new value from a detector only if the new value is larger than the previous trace data value.

PEAKS Peaks

Sorts signal peaks by frequency or amplitude, stores the results in the destination trace, and returns the number of peaks found.

Syntax

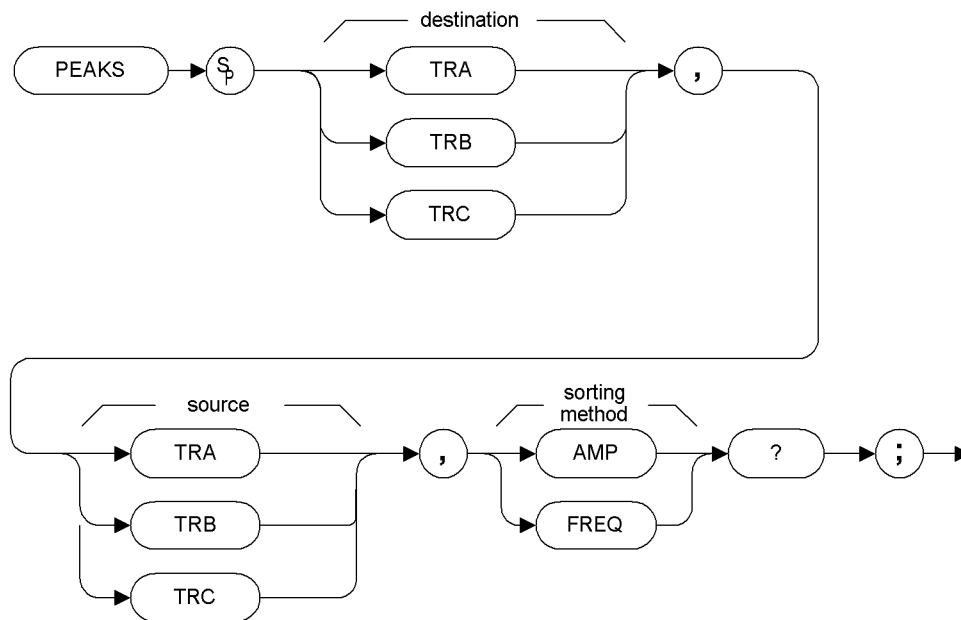

XPEAKS

Prerequisite Commands: TS when using trace data

Description

When sorting by frequency (FREQ), PEAKS first computes the horizontal position of all peaks. These positions are loaded into the destination trace consecutively, with the lowest frequency value occupying the first element. Thus, signal frequencies, from low to high, determine the amplitude of the destination trace from left to right.

When sorting by amplitude (AMP), PEAKS first computes the amplitudes of all peaks in the source trace in measurement units, and sorts these values from high to low. The positions of the peaks are then loaded into the destination trace, with the position of the highest amplitude value occupying the first element.

Programming Commands
PEAKS Peaks

For example, the following spectrum analyzer display shows several peaks:

If the **FREQ** parameter is used with the **PEAKS** command, the displayed peaks would be described by the values shown in the following table.

Figure 3-1 Frequency and Amplitude of the Peaks

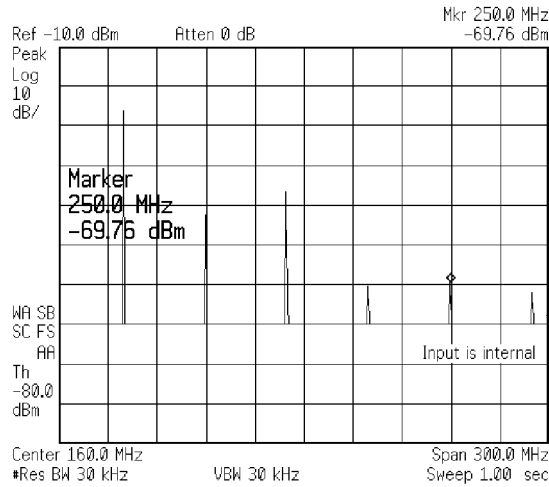

Trace Element	Amplitude	Frequency
TRB[1]	-25.85	4.98E+7
TRB[2]	-53.82	1.E+8
TRB[3]	-46.17	1.495E+8
TRB[4]	-68.65	2.5E+8

If the **AMP** parameter is used with the **PEAKS** command, the displayed peaks would be described by the values that are shown in the following table.

Trace Element	Amplitude	Frequency
TRB[1]	-25.85	4.98E+7
TRB[2]	-46.21	1.495E+8
TRB[3]	-53.81	1.E+8
TRB[4]	-68.24	2.5E+8

Notice that MKA? and MKF? are used to determine the amplitude and frequency of the peak position.

PEAKS sorts only signals that are above the threshold value. To be classified as a signal peak, a signal must be MKPX above the threshold value and it must rise and fall at least the peak excursion (MKPX value). To change the threshold, use the TH command before PEAKS is executed.

If necessary, the last sorted value is repeated to fill remaining elements of the destination trace.

PEAKS must be used as a query. Form a query by ending the PEAKS statement with a "?;". When used as a query, PEAKS returns the number of peaks found.

Query Response

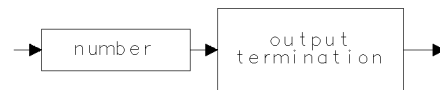

QQ1

PREAMPG External Preamplifier Gain

Subtracts a positive or negative preamplifier gain value from the displayed signal.

Syntax

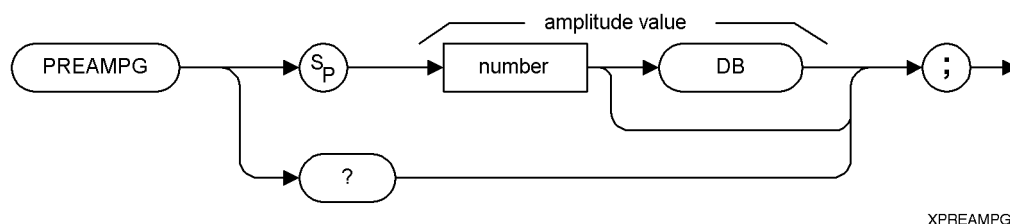

Description

Unlike using ROFFSET, PREAMPG can change the attenuation depending on the preamplifier gain entered.

A preamplifier gain offset is used for measurements that require an external preamplifier or long cables. The offset is subtracted from the amplitude readout so that the displayed signal level represents the signal level at the input of the preamplifier or long cable. The preamplifier gain offset is displayed at the top of the screen and is removed by entering zero.

NOTE

PREAMPG is not reset to 0 by an instrument preset (IP). Be sure to execute "PREAMPG 0;" when the preamplifier gain is no longer needed.

Query Response

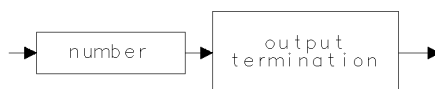

RB Resolution Bandwidth

Specifies the resolution bandwidth.

Syntax

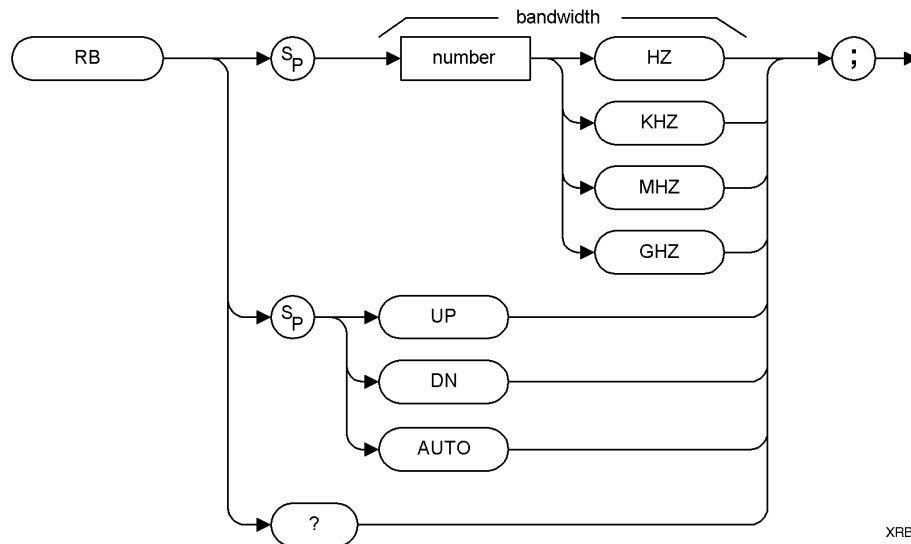

Item	Description/Default	Range
Number	Any real or integer number. Default unit is Hz.	1 kHz to 5 MHz 10 Hz to 5 MHz (option 1DR)

Preset State: 3 MHz.

Step Increment: In a 1, 3, 10.

Description

The coupling between sweep time and resolution bandwidth is terminated by this command. Execute RB AUTO to reestablish coupling. (Also see “AUTO.”)

The front-panel knob, step increment keys, and auto-coupled settings provide a 1, 3, 10 resolution bandwidth sequence only. Frequencies are rounded to the nearest value in the 1, 3, 10 sequence.

Query Response

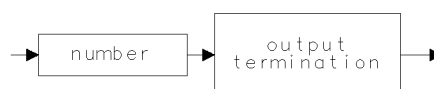

QQ1

RCLS Recall State

Recalls analyzer state data from the specified state register in the analyzer's memory.

Syntax

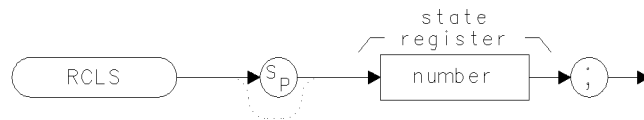

XI

Item	Description/Default	Range
Number	Any real or integer number	1 to 8

Description

Registers 1 through 8 contain instrument state information if instrument state information has been stored in it with the SAVES command.

Differences

8590 Series: Recalling the analyzer to previous state data (RCLS 9) is allowed.

ESA Option 290: Recalling the analyzer to previous state data (RCLS 9) is not allowed.

REV Revision

Returns the date code of the firmware revision date in YYMMDD format (for example, 970910 indicates 10 September 1997).

Syntax

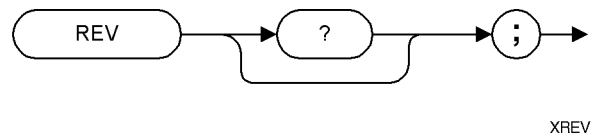

Query Response

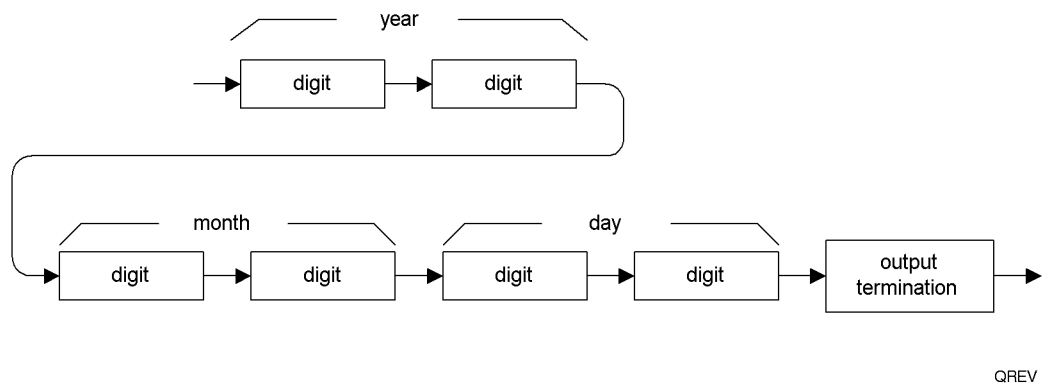

RL Reference Level

Specifies the amplitude value of the reference level.

Syntax

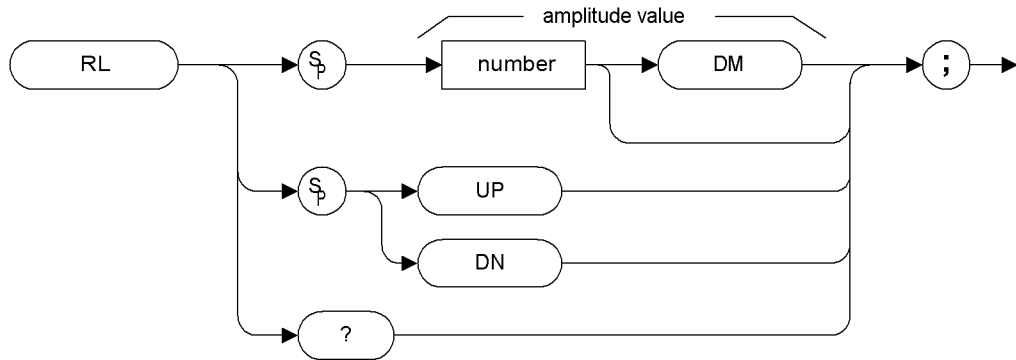

XRL

Item	Description/Default	Range
Number	Any real or integer number. Default unit is the current amplitude unit.	Amplitude range of the spectrum analyzer

Preset State: 0 dBm

Step Increment: by 10 dBm

Description

The reference level and input attenuator are coupled to prevent gain compression. Signals with peaks at or below the reference level are not affected by gain compression.

CAUTION

Signal levels above +30 dBm will damage the spectrum analyzer.

RL may affect the attenuation value.

Query Response

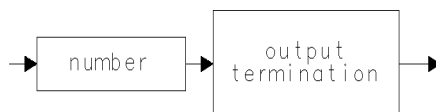

QQ1

RMS Root Mean Square Value

Returns the root mean square value of the trace in measurement units.

Syntax

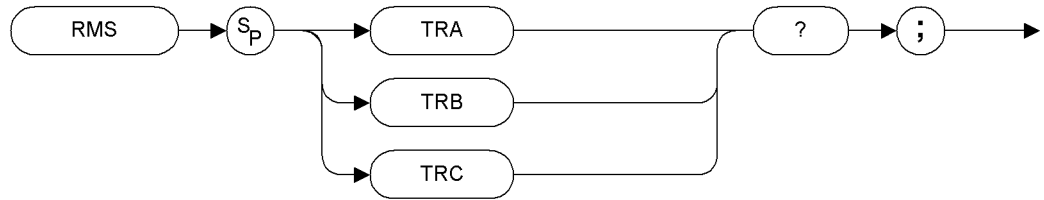

XRMS

Prerequisite Commands: TS when using trace data.

Query Response

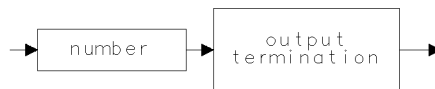

Q01

NOTE

TRA corresponds to Trace 1, TRB corresponds to Trace 2, and TRC corresponds to Trace 3.

ROFFSET Reference Level Offset

Offsets all amplitude readouts without affecting the trace.

Syntax

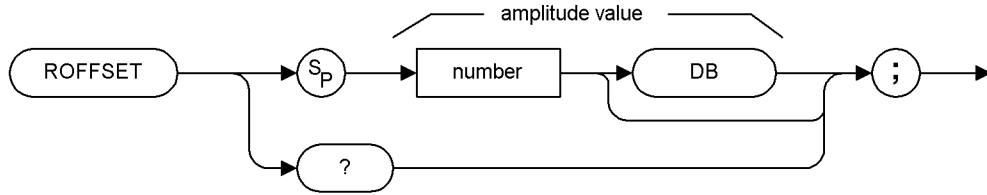

XROFFSET

Item	Description/Default	Range
Number	Any real or integer number. Default unit is dB.	-327.60 dB to +327.60 dB

Preset State: 0 dB.

Description

Once activated, the ROFFSET command displays the amplitude offset on the left side of the screen.

Entering ROFFSET 0 or presetting the spectrum analyzer eliminates an amplitude offset.

Query Response

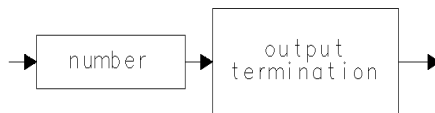

QQ1

RQS Service Request Mask

Sets a bit mask for service requests.

Syntax

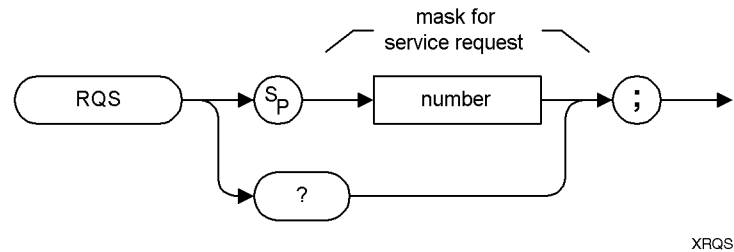

Item	Description/Default	Range
Number	Any valid integer	0 to 63

Preset State: 41

Description

Assignment of values for the mask is as follows:

- 32 = Illegal command (bit 5)
- 16 = Command complete (bit 4)
- 8 = Hardware broken (bit 3)
- 1 = Operator notification (bit 0)

A mask with hardware broken is equal to 8. The mask also disables command complete, illegal command, and operator notification interrupts.

To activate all conditions in the mask, the mask value is equal to 57 (32 + 16 + 8 + 1). To set the service request mask for all conditions, execute `OUTPUT 718;"RQS 57;"`.

Each bit in the status byte is defined as follows:

- 0** Indicates that an operator notification has occurred. SRQ S appears on the analyzer screen. Operator notification occurs if an overload is detected on the analyzer RF input, if excessive reverse power is detected on the RF output (options 1DN or 1DQ only), or if the tracking generator becomes unlevelled (options 1DN or 1DQ only.)

- 1** Not supported by Option 290.
- 2** Not supported by Option 290.
- 3** Indicates broken hardware. SRQ S appears on the spectrum analyzer screen.
- 4** Indicates completion of a command. It is triggered by EOI at the end of a command string or the completion of a print or plot.
- 5** Indicates an illegal spectrum analyzer command was used. SRQ S appears on the spectrum analyzer screen.
- 0** (LSB), **6**, and **7** are not used.

A service request is generated only if the proper request mask bit has been set, and either the condition itself or the Force Service Request is sent. To set the request mask, choose the desired interrupt conditions and sum their assigned values. Executing the RQS command with this value sets the bit mask. After setting the bit mask, only the chosen conditions can produce an interrupt. Generally, you must set the bit mask using the RQS command. However, the “hardware broken”, “operator notification” and “illegal remote command” conditions are automatically enabled after presetting or sending the IP command. Pressing **Preset** or sending the IP command, then, produces the same interrupt bit mask as sending “RQS 41;” (decimal 41 is the sum of the assigned values of these three interrupt bits, 32 = Bit 5, 8 = Bit 3, and 1 = Bit 0).

For most conditions, the RQS mask bit stays set until the next IP or RQS command is executed.

Query Response

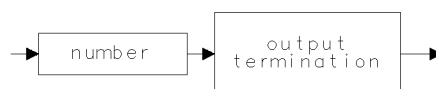

QQ1

Differences

8590 Series: Units Key Pressed (bit 1) and End of Sweep (bit 2) are supported.

ESA Option 290: Units Key Pressed (bit 1) and End of Sweep (bit 2) are not supported. Trying to set a bit mask with bits 1 or 2 enabled will result in a command error message displayed at the bottom of the analyzer’s screen, and a service request for illegal command will be sent.

SAVES

Save State

Saves the currently displayed instrument state in the analyzer's memory.

Syntax

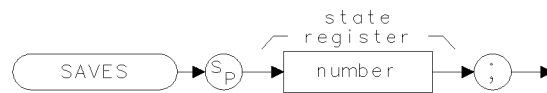

XSAV

Item	Description/Default	Range
Number	Any valid integer	1 to 8

Description

The state data is saved in the specified state register.

Only state registers 1 through 8 are available for saving the instrument state.

SMOOTH Smooth Trace

Smooths the trace according to the number of points specified for the running average.

Syntax

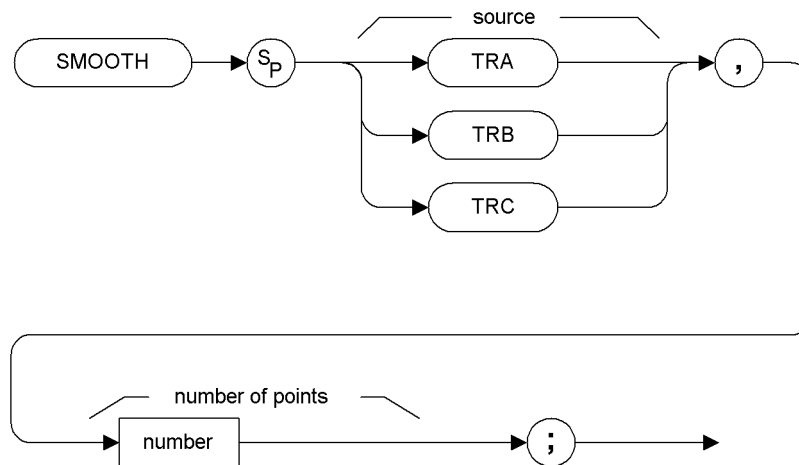

Item	Description/Default	Range
Number	Any real or integer number	Real number range

Prerequisite Commands: TS when using trace data.

Description

Each point value is replaced with the average of the values (in measurement units) of the given number of points centered on it. Increasing the number of points increases smoothing at the cost of decreasing resolution. If the number of points is an even number, then the number of points is increased by one. If the number of points is larger than the size of SOURCE, then the size of SOURCE is used (unless size of SOURCE is even, in which case the size of SOURCE minus one is used). Smoothing decreases at the endpoints.

The purpose of this function is to perform a spatial video averaging as compared to the temporal version supplied by the video-average (VAVG) command. The functions of SMOOTH and VAVG are not interchangeable however. Unlike VAVG, SMOOTH averages values that occur before and after the data point in time. This can cause some display irregularities at the start and stop frequencies. Use low values for the SMOOTH parameter to avoid signal distortion.

By replacing the value of each point in a trace with the average of the values of a number of points centered about that point, any rapid variations in video noise or signals are smoothed into more gradual variations. It thereby performs a function similar to reducing the video bandwidth without the corresponding changes in sweep time. As such, it does result in a reduction of frequency resolution. Also, signal peaks are reduced with large smoothing values, and this can cause the amplitude to appear to be low.

This command requires user memory for its execution. Memory is not permanently allocated, so the largest amount of memory is available for the functions that are used in a particular application. When the command is complete, memory is returned to the free user memory.

SNGLS Single Sweep

Sets the spectrum analyzer to single-sweep mode.

Syntax



XSNGLS

Description

Each time TS (take sweep) is sent, one sweep is initiated, as long as the trigger and data entry conditions are met.

SP Span

Changes the total displayed frequency range symmetrically about the center frequency.

Syntax

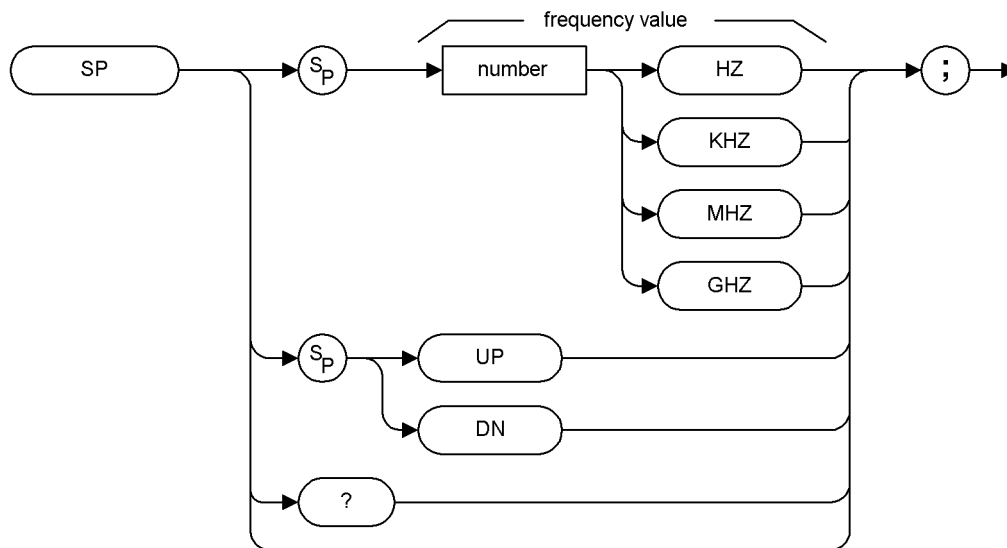

XSP

Item	Description/Default	Range
Number	Any real or integer number. Default unit is Hz.	Frequency span of the spectrum analyzer

Step Increment: 1, 2, 5, 10 sequence (up to the stop frequency of the spectrum analyzer)

Description

The frequency span readout refers to the displayed frequency range. Dividing the readout by 10 yields the frequency span per division.

If resolution and video bandwidths are coupled to the span width, the bandwidths change with the span width to provide a predetermined level of resolution and noise averaging. Likewise, the sweep time changes to maintain a calibrated display, if coupled. All of these functions are normally coupled, unless RB, VB, or ST have been executed.

Programming Commands
SP Span

Because span is affected by frequency, change the frequency before changing span.

Specifying 0 Hz enables zero-span mode, which configures the spectrum analyzer as a fixed-tuned receiver.

Query Response

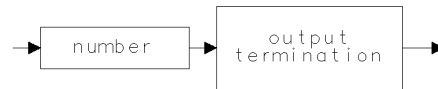

QQ1

SRCAT Source Attenuator

Attenuates the source output level.

Syntax

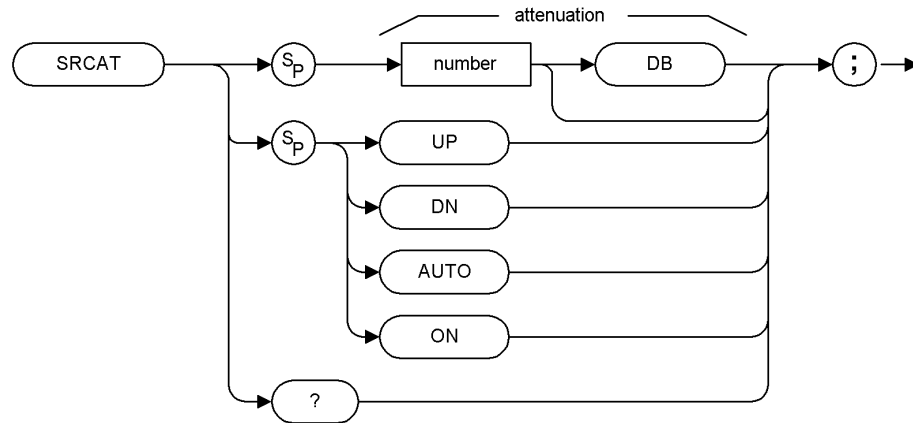

XSRCAT

Item	Description/Default	Range
Number	Any real or integer number, specified in multiples of 10 dB	0 to 60 dB (E4401B/E4411B) 0 to 56 dB (E4402B/03B/04B/05B/07B/08B)

Option Required: Option 1DN or 1DQ

Coupling: Coupled to power level of the source output (SRCPWR) when set to auto (SRCAT AUTO)

Preset State: SRCAT AUTO

Description

The SRCAT command attenuates the output level of the source. Use SRCAT to attenuate the power level of the source manually, from 0 to 60 dB in 10 dB steps for E4401B or E4411B; 0 dB to 56 dB for E4402B, E4403B, E4404B, E4405B, E4407B, or E4408B.

"SRCAT AUTO;" automatically adjusts the attenuator to yield the source amplitude level specified by the SRCPWR command.

Query Response

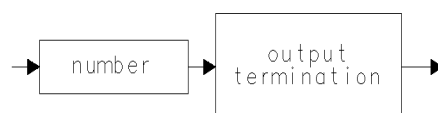

QQ1

SRCPOFS Source Power Offset

Offsets the source power level readout.

Syntax

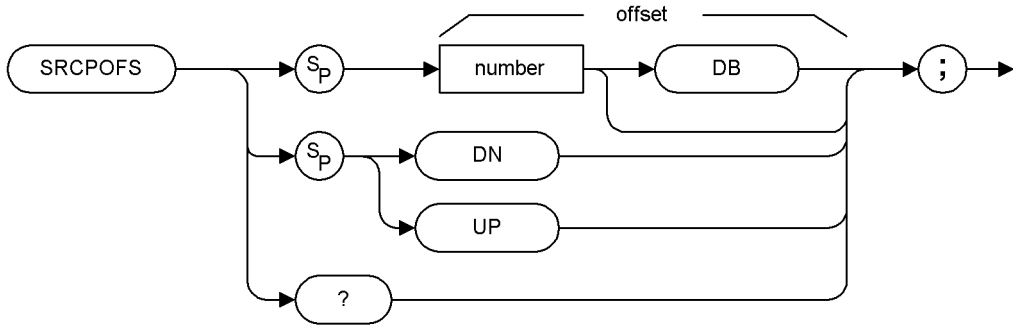

XSRCPOFS

Item	Description/Default	Range
Number	Any real or integer number	

Option Required: Option 1DN or 1DQ.

Step Increment: Determined by SRCPSTP.

Preset State: 0 dB.

Description

The SRCPOFS command offsets the displayed power of the built-in tracking generator. This function may be used to take into account system losses (for example, cable loss) or gains (for example, preamplifier gain) reflecting the actual power delivered to the device under test.

Query Response

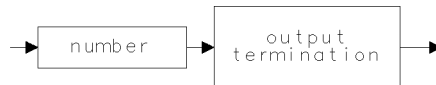

QQ1

SRCPSTP Source Power Level Step Size

Selects the source power step size.

Syntax

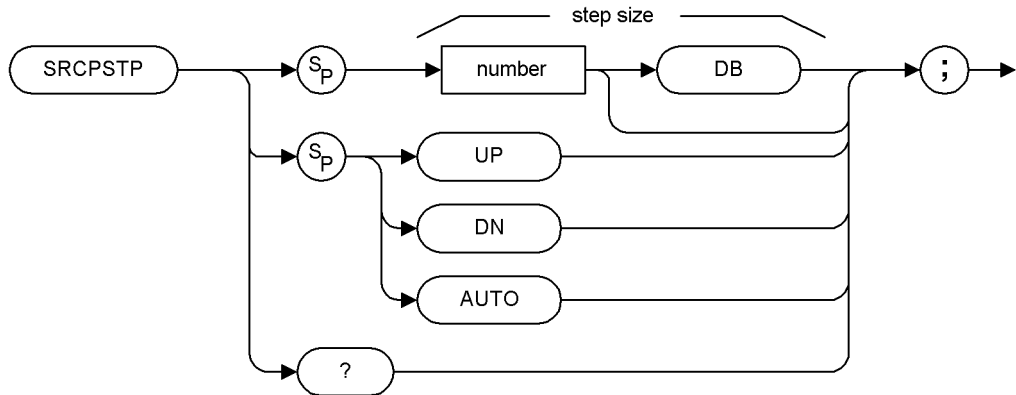

XSRCPSTP

Item	Description/Default	Range
Number	Any real or integer number	

Option Required: Option 1DN or 1DQ.

Step Increment: 10 dB.

Preset State: SRCPSTP AUTO (one major vertical scale division).

Description

The SRCPSTP command selects the step size for the following source commands:

Power offset (SRCPOFS).

Power sweep (SRCPSWP).

Power (SRCPWR).

Use SRCPSTP to set the step size to a specific value.

“SRCPSTP AUTO;” sets the step size to one vertical scale division.

Query Response

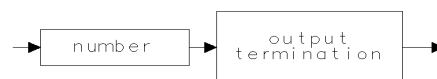

QQ1

SRCPSWP Source Power Sweep

Selects the sweep range of the source output.

Syntax

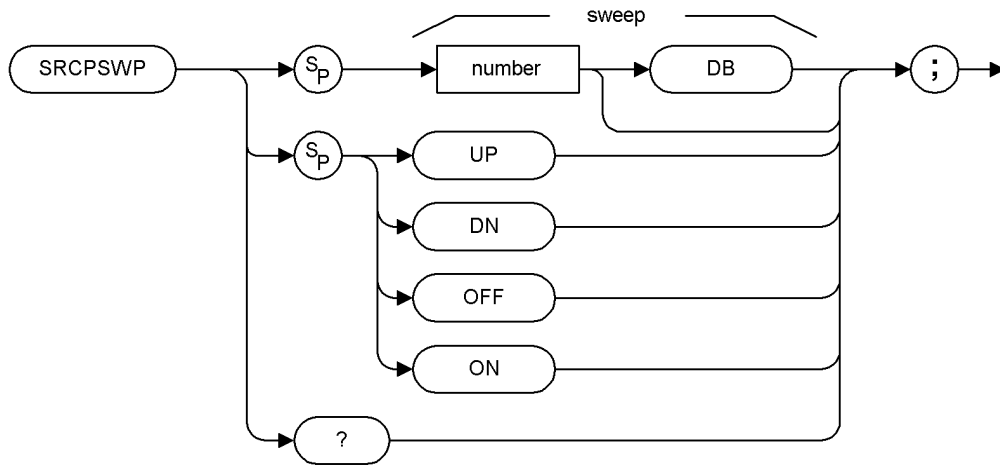

XSRCPSWP

Item	Description/Default	Range
Number	Any real or integer number	

Option Required: Option 1DN or 1DQ.

Step Increment: Determined by SRCPSTP.

Preset State: SRCPSWP OFF.

Description

The SRCPSWP command works in conjunction with the SRCPWR (source power) command to sweep the amplitude level of the source output. The SRCPWR setting determines the amplitude level at the beginning of the sweep. The SRCPSWP command determines the change in amplitude level of the sweep.

For example, if SRCPWR and SRCPSWP are set to -15 dBm and 4 dB respectively, the source sweeps from -15 dBm to -11 dBm.

NOTE Power is swept from low to high.

The minimum sweep time is limited to 50 ms when performing a source power sweep.

Query Response

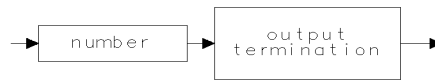

QQ1

SRCPWR Source Power

Selects the source power level.

Syntax

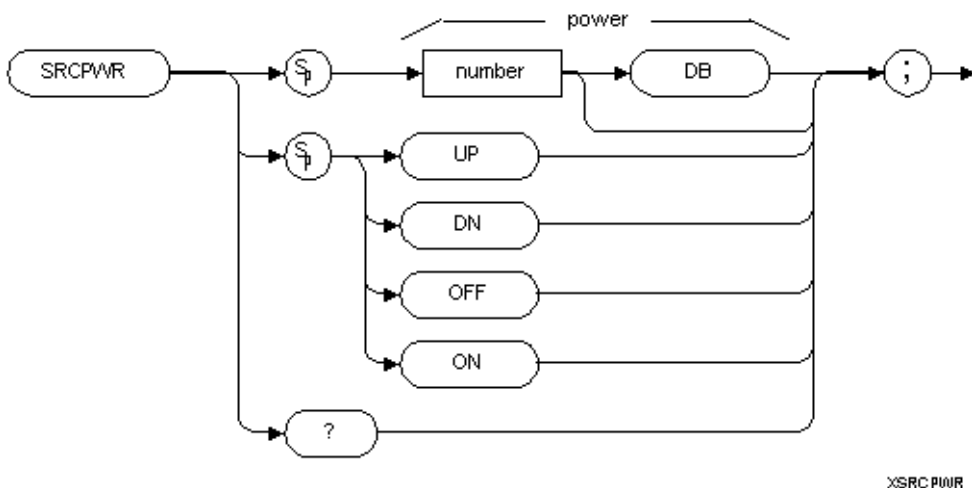

XSRC PWR

Item	Description/Default	Range
Number	Any real or integer number. Default unit is the current amplitude unit.	Actual range is hardware dependent

Option Required: Option 1DN or 1DQ.

Step Increment: Set by SRCPSTP.

Preset State: -10 dBm.

Description

The SRCPWR command turns the source off or on and sets the power level of the source. The source is turned on automatically whenever its value is specified with SRCPWR. Also see “SRCPSTP.”

Query Response

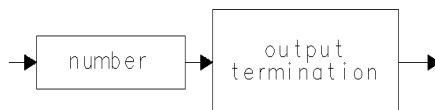

QQ1

SRCTK Source Tracking

Adjusts tracking of source output with analyzer sweep.
(E4402B/03B/04B/05B/07B/08B only)

Syntax

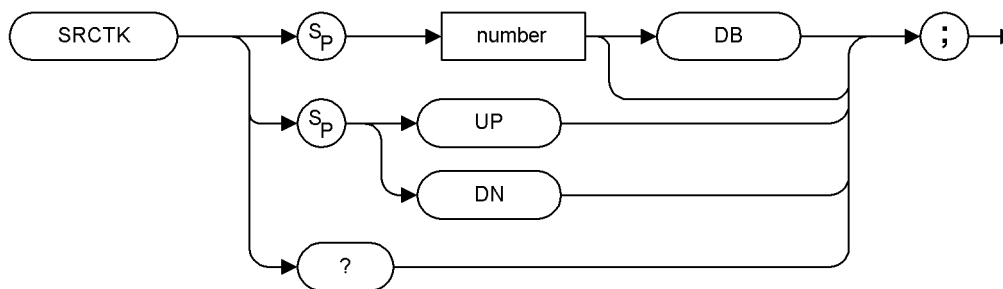

Item	Description/Default	Range
Number	Any real or integer number	0 to 4095

Option Required: Option 1DN

Description

The SRCTK command adjusts the tracking of the tracking-generator output relative to the center frequency of the analyzer. SRCTK is used typically for bandwidths less than 300 kHz. Bandwidths greater than 300 kHz do not require tracking adjustment. Use SRCTKPK to adjust tracking automatically. See “SRCTKPK.”

Query Response

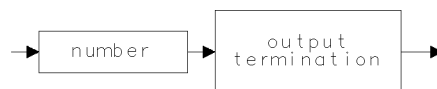

QQ1

Differences

8590 Series: All models require the use of this command if the tracking generator option is installed.

ESA Option 290:ESA models E4401B and E4411B do not use this command (tracking is automatically adjusted, continually).

SRCTKPK Source Tracking Peak

Adjusts tracking of source output with analyzer sweep.
(E4402B/03B/04B/05B/07B/08B only)

Syntax



XSRC

Option Required: Option 1DN

Description

The SRCTKPK command adjusts the tracking of the tracking-generator output automatically to maximize responses for measurements made with resolution bandwidths less than 300 kHz.

SRCTKPK maximizes the amplitude of the displayed active trace.

SS Center Frequency Step Size

Specifies center frequency step size.

Syntax

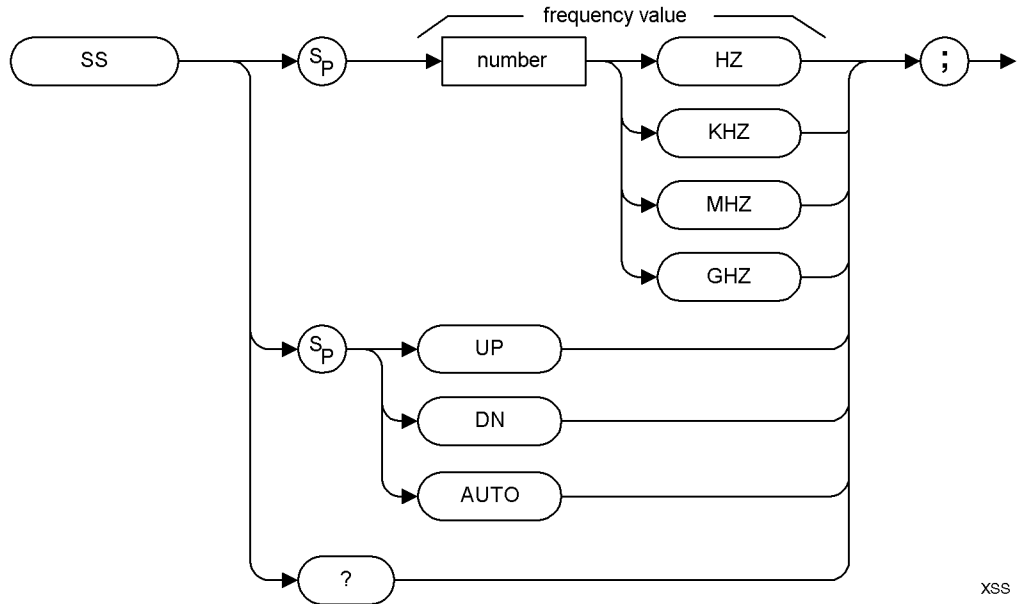

XSS

Item	Description/Default	Range
Number	Any real or integer number. Default unit is Hz.	Frequency range of the spectrum analyzer

Preset State: Hardware dependent.

Step Increment: 1, 2, 5, 10 sequence.

Description

The AUTO parameter removes SS as an active function.

Query Response

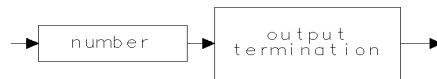

QQ1

Differences

8590 Series: SS AUTO removes Center Frequency Step Size as the current active function, but does not affect the displayed value of the step size. Preset state is 100 MHz.

ESA Option 290: SS AUTO will affect the value of the Center Frequency Step Size. Preset state is hardware dependent.

ST Sweep Time

Specifies the time in which the spectrum analyzer sweeps the displayed frequency range.

Syntax

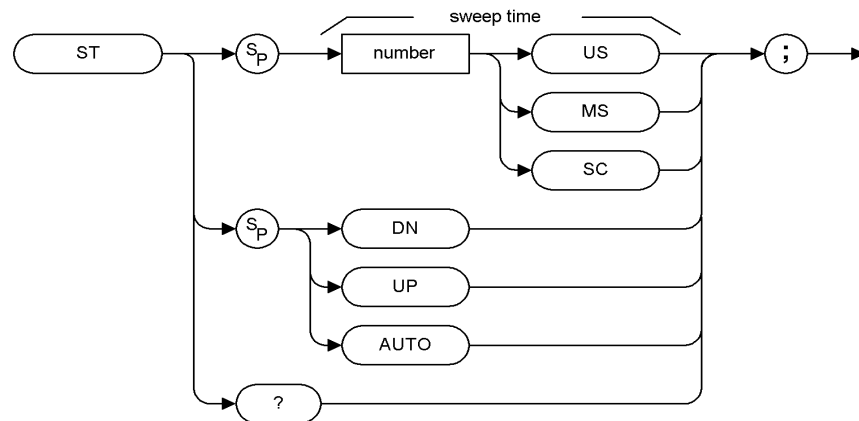

XST

Item	Description/Default	Range
Number	Any real or integer number. Default unit is seconds.	Within the sweep time range of the spectrum analyzer

Sweep Time Range: 1 μ s to 4000 s (5 ns to 4000 s, option AYX)

Step Increment: 2, 3, 5, 7.5, 10, 15 sequence

Query Response

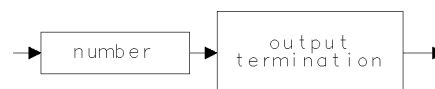

QQ1

STB Status Byte Query

Returns to the controller the decimal equivalent of the status byte.

Syntax

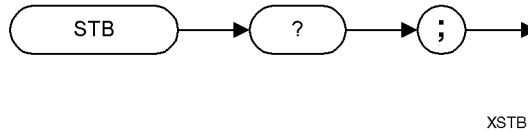

Description

The STB command is equivalent to a serial poll command. The RQS and associated bits are cleared in the same way that a serial poll command would clear them. The bits in the status byte are explained under the RQS command.

Query Response



QQ1

STDEV Standard Deviation of Trace Amplitudes

Returns the standard deviation of the trace amplitude in measurement units.

Syntax

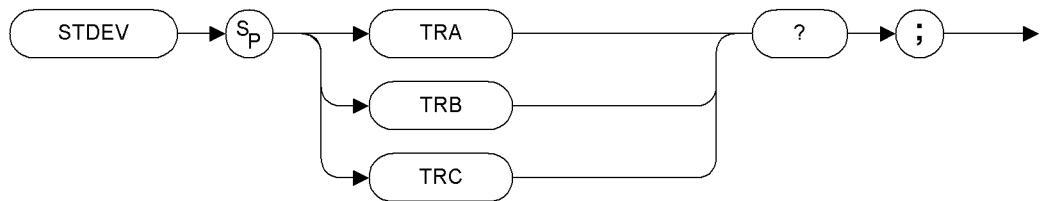

XSTDEV

Prerequisite Commands: TS when using trace data

NOTE

TRA corresponds to Trace 1, TRB corresponds to Trace 2, and TRC corresponds to Trace 3.

Description

The formula to calculate the standard deviation is as follows:

$$\sqrt{\frac{\sum_{i=1}^n (\bar{x} - x_i)^2}{n - 1}}$$

n	represents the number of data points.
x_i	represents a data point.
\bar{x}	represents the mean of data.

Query Response

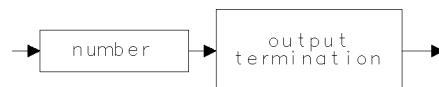

QQ1

TA Trace A

Returns trace 1 amplitude values from the analyzer to the controller.

Syntax

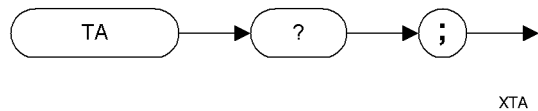

Description

The display unit values are transferred in sequential order (from left to right) as seen on the screen.

Transfer of trace amplitude data should be done only as follows:

1. Select single sweep mode (SNGLS).
2. Select desired analyzer settings.
3. Take one complete sweep (TS).
4. Transfer data (TA).

This procedure ensures that the current settings of the analyzer are reflected in the transferred data.

NOTE

The analyzer must be set to the default number of sweep points (401) for the trace data transfer to be handled properly.

TB Trace B

Transfers trace 2 amplitude values from the analyzer to the controller.

Syntax

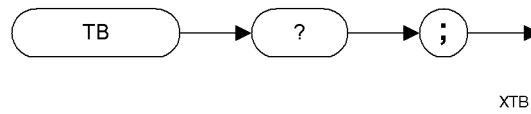

Description

The operation of TB is similar to the operation of TA.

TDF Trace Data Format

Formats trace information for return to the controller.

Syntax

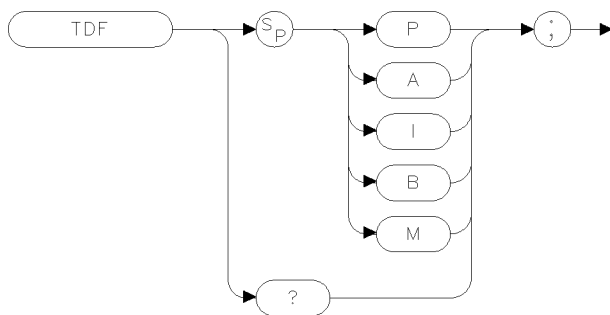

XTDF

Description

The different trace data formats are as follows:

TDF P

Description: TDF P is the real number format. An example of a trace element returned with the real number format is 10.00 dB. When querying the trace or marker value, the value is returned using the amplitude unit set by AUNITS (for example, watts or dBm).

Restrictions: The spectrum analyzer must be in log scale to use TDF P. To send the trace data back to the spectrum analyzer, the data must be converted to measurement units.

How data is returned: The following table describes what is transferred when the trace data format is set to P, but the AUNITS are changed. In every case, the trace data transfer is ended by a carriage return, and a line feed with an EOI.

Table 3-4

Trace Data Transfers with TDF P

AUNITS Setting	Example	Description
Watts	TDF P; AUNITS W; TRA;	Transfers 401 real values, in watts, with each value separated by a carriage return and a line feed.

Table 3-4 Trace Data Transfers with TDF P

AUNITS Setting	Example	Description
dBm	TDF P; AUNITS DBM;TRA;	Transfers 401 real values, in dBm, with each value separated by a carriage return and a line feed.
dBmV	TDF P; AUNITS DBMV;TRA;	Transfers 401 real values, in dBmV, with each value separated by a carriage return and a line feed.
dB μ V	TDF P;AUNITS DBUV;TRA;	Transfers 401 real values, in dB μ V, with each value separated by a carriage return and a line feed.
Volts	TDF P;AUNITS V;TRA;	Transfers 401 real values, in volts, with each value separated by a carriage return and a line feed.

Example of how data is returned: For example, if the reference level of the spectrum analyzer is set to -10 dBm, the amplitude scale is set to 10 dB per division. For this example Trace 1 could contain the following data:

TRA[1] = 8000 (in measurement units), indicating it is at the reference level.

TRA[2] = 7000 (in measurement units), indicating it is 10 dB below the reference level at -10 dBm.

TRA[3] through TRA[401] each contain 6000 (in measurement units), indicating that the trace elements 3 through 401 are all 20 dB below the reference level at -20 dB.

Querying Trace 1 with the TDF P format and AUNITS set to DBM returns ASCII character codes for the following:

$-10.00,-20.00,-30.00$, (-30.00 is repeated 398 times), <CR><LF><EOI>

TDF A

Description: TDF A is the A-block data format. With the A-block data format, trace data is preceded by “#,” “A,” and a two-byte number (the two byte number indicates the number of trace data bytes). The setting of the MDS command determines whether the trace data is transferred as one or two 8-bit bytes.

Restrictions: To use the A-block format for sending data, you must provide the number of data bytes.

How data is returned: The following table describes what is transferred when the trace data format is set to A, but the MDS setting is changed.

Table 3-5 Trace Data Transfers with TDF A

MDS Setting	Example	Description
Binary	TDF A;MDS B;TRA;	Transfers "#A," the number of bytes of trace data, then the 401 bytes of trace data. Using MDS B "reduces" each trace value into one byte by dividing (DIV) the trace value by 32. The trace data transfer is ended with an EOI.
Word	TDF A;MDS W;TRA;	Transfers "#A," the number of bytes of trace data, then 802 bytes of trace data. MDS W uses two bytes per trace element to transfer trace data. The first byte contains the trace value divided by (DIV) 256, the second byte contains the remainder (MOD) of that division. The trace data transfer is ended with an EOI.

Example of how data is returned: For the same example and Trace 1 data that is used in the TDF P description, querying Trace 1 with the TDF A format and MDS set to binary (MDS B) would return the ASCII character codes for the following:

#A(401 div 256)(401 mod 256)(8000 div 32)(7000 div 32)(6000 div 32)(the number for 6000 div 32 is repeated 398 times)<EOI>

Notice that #A is followed by the two bytes that contain the number of trace elements. Because MDS is set to binary, the number of trace elements is 401.

If MDS is set to W, querying Trace 1 with the TDF A format would return the ASCII character codes for the following:

#A(802 div 256)(802 mod 256)(8000 div 256)(8000 mod 256)(7000 div 256)(7000 mod 256)(6000 div 256)(6000 mod 256)(the number for 6000 div 256, then the number for 6000 mod 256 is repeated 398 times)

Notice that #A is followed by the two bytes that contain the number of trace elements. Because MDS is set to W (word), the number of trace elements is 802.

TDF I

Description: TDF I is the I-block data format. With the I-block data format, trace data must be preceded by “#,” and “I.” The setting of the MDS command determines whether the trace data is transferred as one or two 8-bit bytes. Unlike using the A-block format, you do not provide the number of data bytes when sending trace data back to the spectrum analyzer.

Restrictions: This format is not recommended for use with an RS-232 interface.

How data is returned: The following table describes what is transferred when the trace data format is set to I, but the MDS setting is changed.

MDS Setting	Example	Description
Binary	TDF I;MDS B; TRA;	Transfers “#I,” then the 401 bytes of trace data. Using MDS B “reduces” the trace value into 1 byte by dividing (DIV) the trace value by 32. The trace data transfer is ended with an EOI.
Word	TDF I;MDS W; TRA;	Transfers “#A,” two bytes with length information, then 802 bytes of trace data. MDS W uses two bytes per trace element to transfer trace data. The first byte contains the trace value divided by (DIV) 256, the second byte contains the remainder (MOD) of that division. The trace data transfer is ended with an EOI.

Example of how data is returned: For the same example and Trace 1 data that is used in the TDF P description, querying Trace 1 with the TDF I format and MDS set to binary (MDS B) would return the ASCII character codes for the following:

#I(8000 div 32)(7000 div 32)(6000 div 32)(the number for 6000 div 32 is repeated 398 times)

If MDS is set to W, querying Trace 1 with the TDF I format would return the ASCII character codes for the following:

#I(8000 div 256)(8000 mod 256)(7000 div 32)(7000 mod 256)(6000 div 256)(6000 mod 256)(the number for 6000 div 256, then the number for 6000 mod 256 is repeated 398 times)

TDF B

Description: TDF B enables the binary format. With the binary format, the marker or trace data is transferred as bytes. Of all the trace data formats, TDF B transfers trace data the fastest. The setting of the MDS command determines whether the trace data is transferred as one or two 8-bit bytes.

Restrictions: The TDF B format cannot be used to send data back to the spectrum analyzer (you must use the A-block format to send data back to the spectrum analyzer).

How data is returned: The following table describes what is transferred when the trace data format is set to B, but the MDS setting is changed.

Table 3-6 Trace Data Transfers with TDF B

MDS Setting	Example	Description
Binary	TDF B;MDS B; TRA;	Transfers the 401 bytes of trace data. Using MDS B “reduces” the trace value into 1 byte by dividing (DIV) the trace value by 32. The trace data transfer is ended with an EOI.
Word	TDF B;MDS W; TRA;	Transfers the 802 bytes of trace data.MDS W uses two bytes per trace element to transfer trace data. The first byte contains the trace value divided by (DIV) 256, the second byte contains the remainder (MOD) of that division. The trace data transfer is ended with an EOI.

Example of how data is returned: For the same Trace 1 data that is used in the TDF P description, querying Trace 1 with the TDF B format and MDS set to binary (MDS B) would return the ASCII character codes for the following:

(8000 div 32)(7000 div 32)(6000 div 32)(the number for 6000 div 32 is repeated 398 times)

If MDS is set to W, querying Trace 1 with the TDF B format would return the ASCII character codes for following:

(8000 div 256)(8000 mod 256)(7000 div 32)(7000 mod 256)(6000 div 256)(6000 mod 256)(the number for 6000 div 256, then the number for 6000 mod 256 is repeated 398 times)

TDF M

Description: TDF M is the measurement data format. The measurement data format transfers trace data in measurement units, and the measurement data can range from -32768 to +32767.

Restrictions: TDF M cannot be used to send trace data back to the spectrum analyzer.

How trace data is returned: The following table describes what is transferred when the trace data format is set to M.

Table 3-7

Trace Data Transfers with TDF M

Example	Description
TDF M;TRA;	Transfers 401 bytes, with each trace value in measurement units. The trace data transfer is ended with a carriage return, a line feed with an EOI.

Example of how data is returned: For the same example and Trace 1 data that is used in the TDF P description, querying Trace 1 with the TDF M would return the ASCII character codes for the following:

8000,7000,6000,(6000 repeated 398 times),<CR><LF>

Query Response

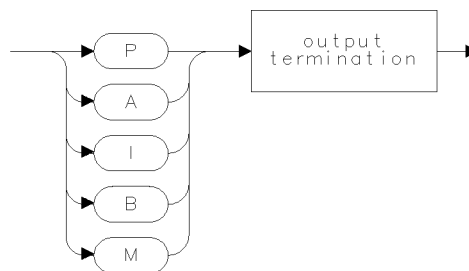

TH Threshold

Sets the minimum amplitude of signals that the marker can identify as a peak.

Syntax

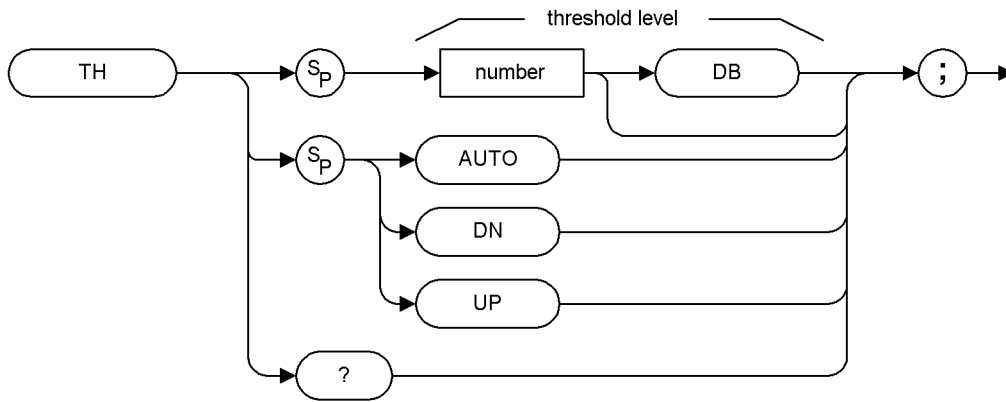

XTH

Item	Description/Default	Range
Number	Any real or integer number. Default unit is dBm.	Range dependent on RL setting

Preset State: Positioned one division above bottom graticule line.

Step Increment: One division.

Description

The threshold level is at -90 dBm unless otherwise specified. The TH level is used for next peak marker movements (see “MKPK”) and the PEAKS command.

Query Response

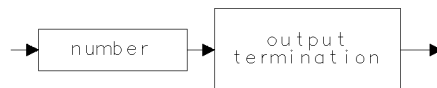

QQ1

Differences

8590 Series: Clips signal responses below the threshold level so that nothing is displayed. AUTO deactivates display clipping. The TH level is used for peak marker movements and the PEAKS command even if the display clipping is off.

ESA Option 290: Signal responses below the threshold level are not clipped. The TH command is mapped to the Pk Threshold setting for peak marker searches. This allows the effect of the command on peak marker movements and the PEAKS command to be preserved.

TM Trigger Mode

Selects a trigger mode: free, line, video, or external.

Syntax

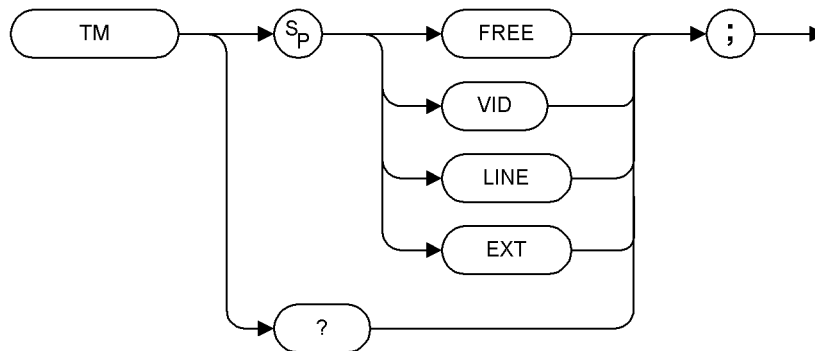

XTM

Description

The conditions of the four trigger modes are as follows:

- FREE** allows the next sweep to start as soon as possible after the last sweep. The functions of TM FREE and FREE RUN are identical.
- VID** allows the next sweep to start if the trace data rises across a level set by the display line. The functions of TM VID and VIDEO are identical.
- LINE** allows the next sweep to start when the line voltage passes through zero, going positive. The functions of TM LINE and LINE are identical.
- EXT** allows the next sweep to start when an external voltage level passes through approximately 1.5 V, going positive. The external trigger signal level must be between 0 V and +5 V. Connect the external trigger to the EXT TRIG INPUT. The functions of TM EXT and EXTERNAL are identical.

NOTE Some spectrum analyzer functions are not performed until the spectrum analyzer is triggered.

Query Response

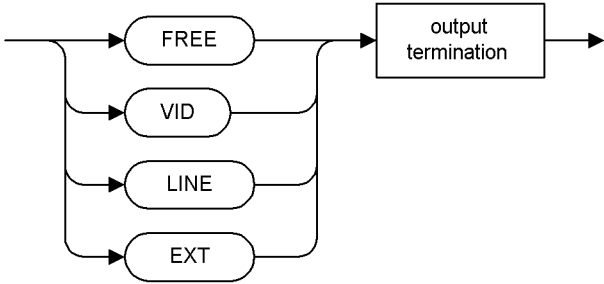

QTM

TRA/TRB/TRC Trace Data Input and Output

The TRA/TRB/TRC commands provide a method for returning, storing or changing the 16-bit trace values.

Syntax

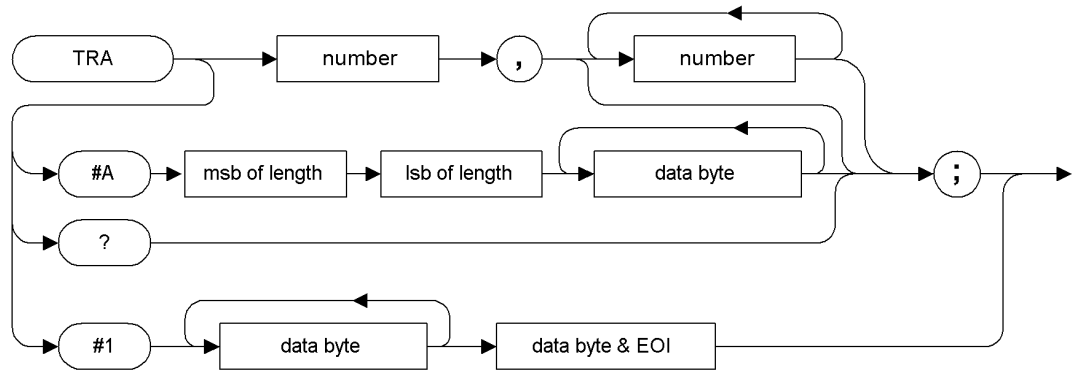

XTRA

Use the same syntax for TRB and TRC as shown for TRA, just substitute TRB or TRC for TRA.

Item	Description/Default	Range
Number	Any real or integer number.	Integer number range
MSB length	Most significant byte of a two-byte word that describes the number of bytes transmitted.	See Table on page 3-35
LSB length	Least significant byte of a two-byte word that describes the number of bytes transmitted.	See Table on page 3-35
Data byte	8-bit byte containing numeric or character data. A typical trace has 401 data bytes.	See Table on page 3-35
Data byte & EOI	8-bit byte containing numeric or character data followed by END.	See Table on page 3-35

Description

The TRA command may be used to input integer data to traces. Because the lengths of trace 1, trace 2, and trace 3 are fixed, there are always 401 bytes transferred during binary input mode.

Trace data that is input in the A-block or the I-block format is treated as measurement units independent of trace data format (TDF) and is preceded by a #A or #I (See the command syntax.) For a 401 point trace, the lsb of the length is 145 (401–256) and the msb of the length is 1 (the integer part of 401/256). Trace data that is input in the A-block, I-block, or B-block format can be sent in byte or word format (MDS). Enter words in measurement units only.

A single trace point can be input by identifying which of the 401 trace points it is, and sending the desired trace value in measurement units.

Query Response

When TRA is queried to output trace data, the output format is specified by the TDF and MDS commands. Because the lengths of trace 1, trace 2, and trace 3 are fixed, there are always 802 bytes transferred during binary output mode.

The form of the query response is dependent upon the previously used TDF and MDS commands as follows:

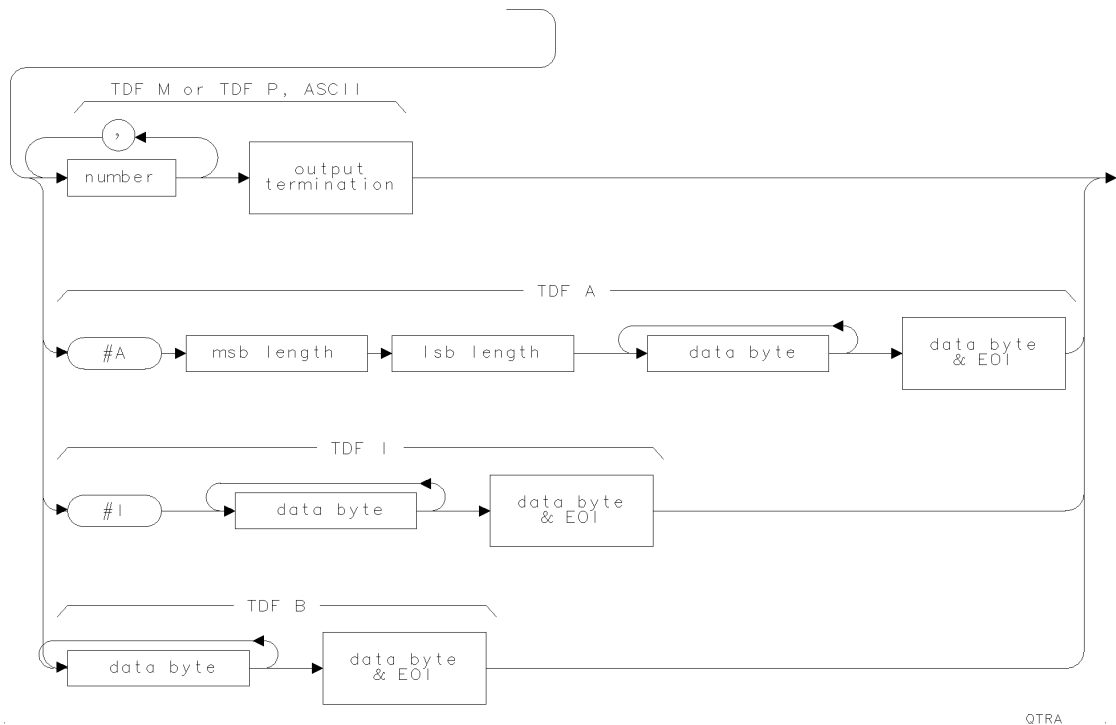

TS Take Sweep

Starts and completes one full sweep before the next command is executed.

Syntax



XTS

Description

A take sweep is required for each sweep in the single-sweep mode. TS prevents further input from the interface bus until the sweep is completed to allow synchronization with other instruments.

In the example below, the command sequence does not allow sufficient time for a full sweep of the specified span before VIEW is executed. Therefore, only the span set by the instrument is displayed in Trace 1.

```
OUTPUT 718;"IP;SNGLS;CF 400MHZ;SP 20KHZ;VIEW TRA;"
```

A TS command inserted before VIEW makes the spectrum analyzer take one complete sweep before displaying Trace 1. This allows the spectrum analyzer sufficient time to respond to each command in the sequence.

```
OUTPUT 718;"IP;CF 400MHZ;SP 20MHZ;TS;VIEW TRA;"
```

TS is recommended before transmission of marker data and before executing marker operations such as peak search. This is because the active marker is repositioned at the end of each sweep. When the spectrum analyzer receives a TS command, it is not ready to receive any more data until one full sweep has been completed. However, when slow sweep speeds are being used, the controller can be programmed to perform computations or address other instruments while the spectrum analyzer completes its sweep.

UP Up

Increases the value of the current function by the applicable step size.

Syntax



XUP

Description

Before executing UP, be sure that the command for the desired function to be increased has been previously sent.

The active functions are AT, CF, DL, FA, FB, LG, MKD, MKFCR, MKN, MKPX, ML, RB, RL, ROFFSET, SP, SRCAT, SRCPOFS, SRCPSWP, SRCPWR, SRCTK, SS, ST, VB, and VBR.

Differences

8590 Series: As a stand-alone command, affects the parameter whose active function is enabled.

ESA Option 290: As a stand-alone command, affects the last relevant parameter whose remote command was sent.

VAVG Video Average

Enables the video-averaging function, which averages trace points to smooth the displayed trace.

Syntax

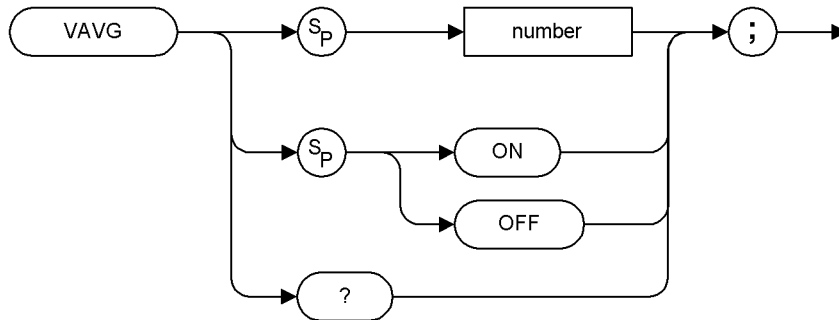

XVAVG

Item	Description/Default	Range
Number	Any valid integer. Default is 100.	1 to 8192

Description

Use VAVG to view low-level signals without slowing the sweep time. Video averaging can lower the noise floor by more than a 30 Hz video bandwidth if a large number of sweeps has been specified for averaging. VAVG may also be used to monitor instrument state changes (for example, changing bandwidths, center frequencies) while maintaining a low noise floor.

The default for the number of sweeps is 100 unless otherwise specified. If the number of sweeps is changed, the new number will be remembered when the function is turned off and back on again.

In single sweep mode the selected number of sweeps (N) are taken. Executing “VAVG OFF;” or “VAVG ON;” turns off/on video averaging. After each sweep, the new value of each display point is averaged in with the previously averaged data using the following formula:

$$A_{\text{avg}} = \left(\frac{M-1}{M}\right)A_{\text{prior avg}} + \left(\frac{1}{M}\right)A_m$$

Where:

A_{avg} = new average value

$A_{\text{prior avg}}$ = average from prior sweep

A_m = measured value on current sweep

M = number of current sweep

In continuous sweep mode the same sequence is followed until M=N. At that point, the sweeps continue rather than stopping. For each new sweep, the current sweep's measured value divided by N is added to (N-1)/N times the prior average, creating a weighted rolling average.

If a measurement parameter such as center frequency, span, or N is changed while video average is on, the video average counter is reset to 0. If the analyzer is in single sweep mode, a new set of sweeps is taken.

When video averaging is turned on the sample detector mode is automatically switched in. When the averaging is switched off, the detector mode is reset to the previous mode.

Query Response

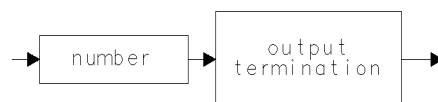

Q01

Differences

8590 Series: Changing the average counter number to a higher number will not reset the count. Changing the average counter to a lower number will update the screen annotation. Range is 1 to 16384.

ESA Option 290: Changing the average counter number to a higher number will reset the count. Changing the average counter to a lower number will not update the screen annotation. Range is 1 to 8192.

VB **Video Bandwidth**

Specifies the video bandwidth, which is a post-detection, low-pass filter.

Syntax

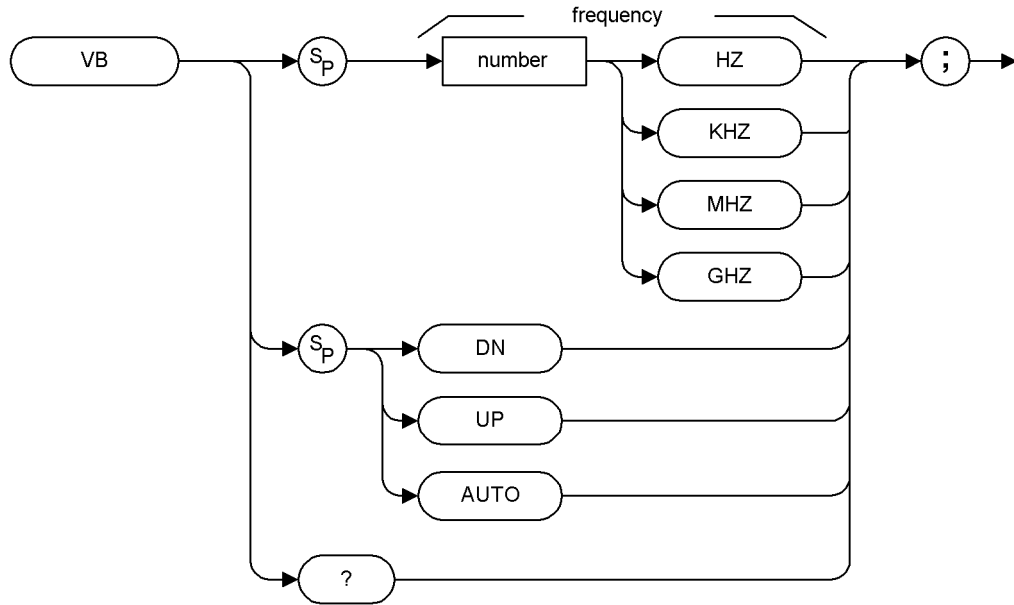

XVB

Item	Description/Default	Range
Number	Any real or integer number. Default unit is Hz.	30 Hz to 3 MHz

Preset State: 3 MHz.

Step Increment: In a 1, 3, 10 sequence.

Description

The resolution bandwidth, video bandwidth, and sweep time are normally coupled to the span. Executing a VB command (other than AUTO) uncouples video bandwidth from resolution bandwidth (it does nothing to the sweep-time, resolution-bandwidth, and span coupling). Executing VB AUTO re-couples video bandwidth to the resolution bandwidth.

Frequency values other than the values in the 1, 3, 10 sequence are rounded to the nearest permissible value.

Query Response

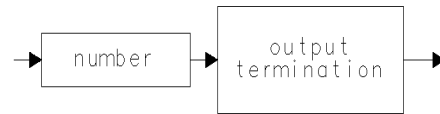

QQ1

Differences

8590 Series: The minimum VB (video bandwidth) value is 1 Hz.

ESA Option 290: The minimum VB (video bandwidth) value is 30 Hz.

VBR Video Bandwidth Ratio

The VBR parameter is multiplied by the resolution bandwidth to determine the automatic setting of video bandwidth.

Syntax

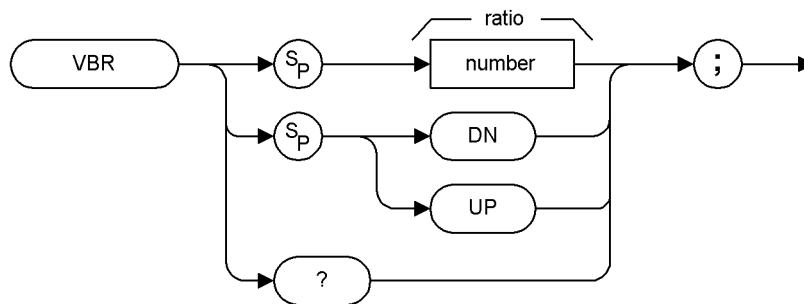

XVBR

Item	Description/Default Example	Range
Number	Any valid real number	0.00001 to 3000000

Preset State: 1.0

Step Increment: 1, 3, 10 sequence

Description

Ratio values other than the values in the 1, 3, 10 sequence are rounded to the nearest permissible value.

Query Response

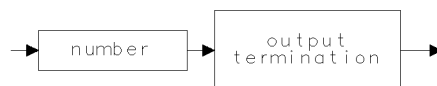

QQ1

Differences

8590 Series: 8590 E-Series preset state is 0.300.

ESA Option 290: Preset state is 1.0.

VIEW

View Trace

Displays Trace 1, trace 2, or trace 3, and stops taking new data into the viewed trace.

Syntax

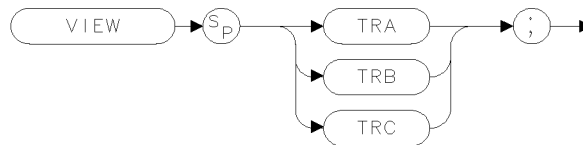

xv

Description

In the VIEW mode the trace is not updated. When VIEW is executed, the contents of the trace are stored in display memory.

NOTE

TRA corresponds to Trace 1, TRB corresponds to Trace 2, and TRC corresponds to Trace 3.

Programming Commands
VIEW View Trace

4 If You Have a Problem

This chapter includes information on how to check for a problem with your ESA spectrum analyzer, and how to return it for service.

If you have a Problem

Your analyzer is built to provide dependable service. However, if you experience a problem, or if you desire additional information or wish to order parts or accessories, the Agilent Technologies worldwide sales and service organization is ready to provide the support you need.

In general, a problem can be caused by a hardware failure, a software error, or a user error. Follow these general steps to determine the cause and to resolve the problem.

1. Perform the quick checks listed in “Check the Basics” in this chapter. It is possible that a quick check may eliminate your problem altogether.
2. If the problem is a hardware problem, you have two options:
 - Repair it yourself; see the “[Service Options](#)” section in this chapter.

WARNING

There are no operator serviceable parts inside the analyzer. Refer servicing to qualified personnel. To prevent electrical shock do not remove covers.

- Return the analyzer to Agilent Technologies for repair; if the analyzer is still under warranty or is covered by an Agilent Technologies maintenance contract, it will be repaired under the terms of the warranty or plan (the warranty is at the front of this manual).

If the analyzer is no longer under warranty or is not covered by an Agilent Technologies maintenance plan, Agilent Technologies will notify you of the cost of the repair after examining the instrument. See “[How to Get in Touch With Agilent Technologies](#)” and “[How to Return Your Analyzer for Service](#)” for more information.

3. If the problem is a software problem, you have two options:
 - Reinstall the firmware and or the 8590-Series Programming Code Compatibility software.
 - Return the analyzer to Agilent Technologies for repair; if the analyzer is still under warranty or is covered by an Agilent Technologies maintenance contract, it will be repaired under the terms of the warranty or plan (the warranty is at the front of this manual).

If the analyzer is no longer under warranty or is not covered by an Agilent Technologies maintenance plan, Agilent Technologies will notify you of the cost of the repair after examining the instrument. See [“How to Get in Touch With Agilent Technologies”](#) and [“How to Return Your Analyzer for Service”](#) for more information.

Before You Call Agilent Technologies

Check the Basics

A problem can often be resolved by repeating the procedure you were following when the problem occurred. Before calling Agilent Technologies or returning the analyzer for service, please make the following checks:

- Check the line fuse.
- Is there power at the receptacle?
- Is the analyzer turned on? Make sure the fan is running, this indicates that the power supply is on.
- If the display is dark or dim, press the upper **Viewing Angle** key in the upper-left corner of the front panel. If the display is too bright, adjust the lower **Viewing Angle** key in the upper-left corner of the front panel.
- If other equipment, cables, and connectors are being used with your ESA spectrum analyzer, make sure they are connected properly and operating correctly.
- Review the procedure for the measurement being performed when the problem appeared. Are all the settings correct?
- If the analyzer is not functioning as expected, return the analyzer to a known state by pressing the **Preset** key.

Some analyzer settings are not affected by a Preset. If you wish to reset the analyzer configuration to the state it was in when it was originally sent from the factory, press **System, Power On/Preset, Preset (Factory)**.

- Is the measurement being performed and the results that are expected, within the specifications and capabilities of the analyzer? Refer to the “Specifications” chapters in the *ESA Spectrum Analyzers Specification Guide* for analyzer specifications.
- In order to meet specifications, the analyzer must be aligned. Either **Auto Align All** must be selected (press **System, Alignments, Auto Align, All**), or the analyzer must be manually aligned at least once per hour, or whenever the temperature changes more than 3 degrees centigrade. When **Auto Align, All** is selected, **AA** appears on the left edge of the display.
- Is the analyzer displaying an error message? If so, refer to Error Messages in the *Agilent ESA Spectrum Analyzers User’s Guide*.
- If the necessary test equipment is available, perform the performance verification tests in the *ESA Spectrum Analyzers Calibration Guide*. Record all results on a Performance Verification Test Record form located after the test descriptions.

- If the equipment to perform the performance verification tests is not available, you may still be able to perform the functional checks in the *ESA Spectrum Analyzers User's Guide*.

Read the Warranty

The warranty for your analyzer is at the front of this manual. Please read it and become familiar with its terms.

If your analyzer is covered by a separate maintenance agreement, please be familiar with its terms.

Service Options

Agilent Technologies offers several optional maintenance plans to service your analyzer after the warranty has expired. Call your Agilent Technologies sales and service office for full details.

If you want to service the analyzer yourself after the warranty expires, you can purchase the service documentation that provides all necessary test and maintenance information.

You can order the service documentation, **Option OBW** (assembly level troubleshooting and adjustment procedures) and **Option OBV** (component level information including parts lists, component location diagrams and schematic diagrams), through your Agilent Technologies sales and service office. Service documentation is described under “Service Documentation and Adjustment Software (Option OBW)” and “Component Level Service Documentation (Option OBV)” in *ESA Spectrum Analyzers User's Guide*.

How to Get in Touch With Agilent Technologies

Agilent Technologies has sales and service offices around the world to provide you with complete support for your analyzer. To obtain servicing information or to order replacement parts, get in touch with the nearest Agilent Technologies office listed in [Table 4-1](#). In any correspondence or telephone conversations, refer to your analyzer by its product number, full serial number, and firmware revision. (Press **System**, **More**, **Show System**, and the product number, serial number, and firmware revision information will be displayed on your analyzer screen.) A serial number label is also attached to the rear panel of the analyzer.

Table 4-1 Contacting Agilent

Online assistance: www.agilent.com/find/assist

United States (tel) 1 800 452 4844	Japan (tel) (+81) 426 56 7832 (fax) (+81) 426 56 7840	New Zealand (tel) 0 800 738 378 (fax) (+64) 4 495 8950	Europe (tel) (+31) 20 547 2323 (fax) (+31) 20 547 2390
Canada (tel) 1 877 894 4414 (fax) (905) 282 6495	Latin America (tel) (305) 269 7500 (fax) (305) 269 7599	Australia (tel) 1 800 629 485 (fax) (+61) 3 9210 5947	

Asia Call Center Numbers

Country	Phone Number	Fax Number
Singapore	1-800-375-8100	(65) 836-0252
Malaysia	1-800-828-848	1-800-801664
Philippines	(632) 8426802 1-800-16510170 (PLDT Subscriber Only)	(632) 8426809 1-800-16510288 (PLDT Subscriber Only)
Thailand	(088) 226-008 (outside Bangkok) (662) 661-3999 (within Bangkok)	(66) 1-661-3714
Hong Kong	800-930-871	(852) 2506 9233
Taiwan	0800-047-866	(886) 2 25456723
People's Republic of China	800-810-0189 (preferred) 10800-650-0021	10800-650-0121
India	1-600-11-2929	000-800-650-1101

How to Return Your Analyzer for Service

Service Tag

If you are returning your analyzer to Agilent Technologies for servicing, fill in and attach a blue service tag. Several service tags are supplied at the end of this chapter. Please be as specific as possible about the nature of the problem. If you have recorded any error messages that appeared on the display, or have completed a Performance Test Record, or have any other specific data on the performance of your analyzer, please send a copy of this information with your analyzer.

Original Packaging

Before shipping, pack the unit in the original factory packaging materials if they are available. If the original materials were not retained, see [“Other Packaging”](#).

NOTE Ensure that the instrument handle is in the rear-facing position in order to reduce the possibility of damage during shipping. Refer to [Figure 4-1](#).

NOTE Install the transportation disk into the floppy drive to reduce the possibility of damage during shipping. If the original transportation disk is not available, a blank floppy may be substituted.

If You Have a Problem
How to Return Your Analyzer for Service

Figure 4-1

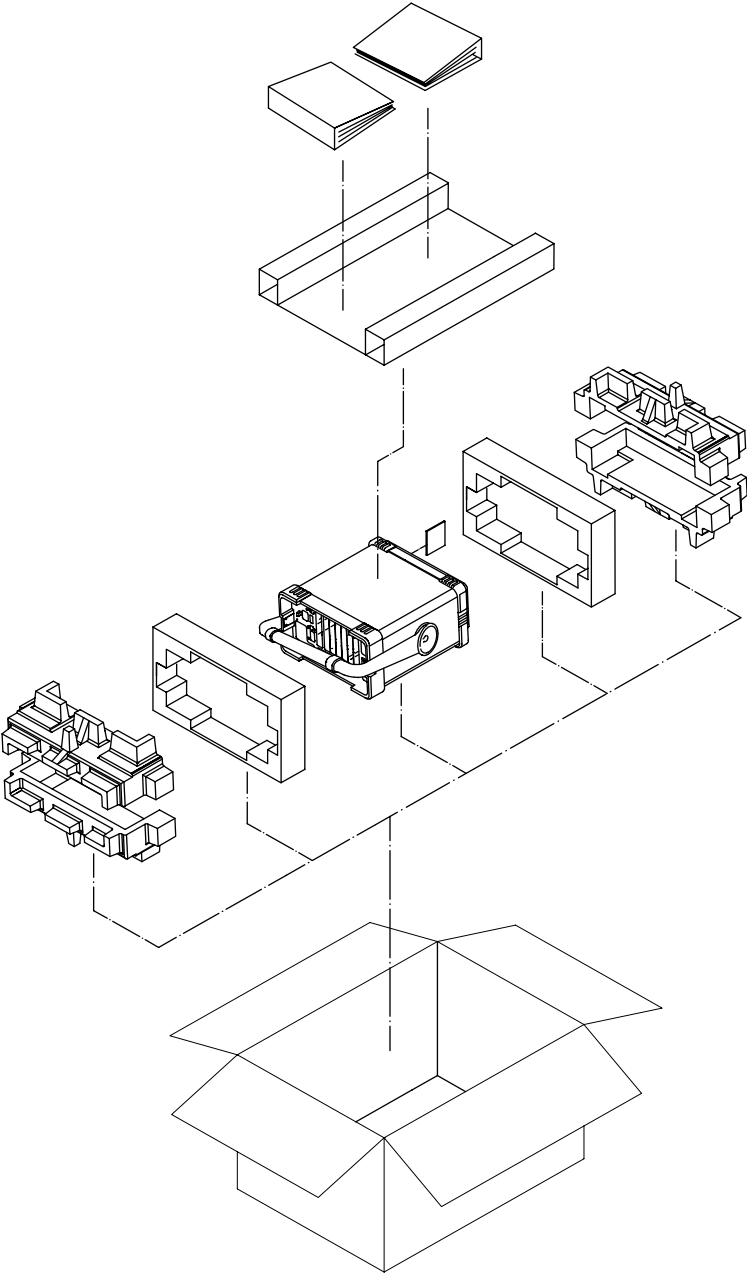

form122

Other Packaging

CAUTION

Analyzer damage can result from using packaging materials other than those specified. Never use styrene pellets in any shape as packaging materials. They do not adequately cushion the equipment or prevent it from shifting in the carton. They cause equipment damage by generating static electricity and by lodging in the analyzer louvers, blocking airflow.

You can repackage the instrument with commercially available materials, as follows:

1. Attach a completed service tag to the instrument.
2. Install the transportation disk or a blank floppy disk into the disk drive.
3. If you have a front-panel cover, install it on the instrument. If you do not have a front panel cover, make sure the instrument handle is in the forward-facing position to protect the control panel.
4. Wrap the instrument in antistatic plastic to reduce the possibility of damage caused by electrostatic discharge.
5. Use a strong shipping container. The carton must be both large enough and strong enough to accommodate the analyzer. A double-walled, corrugated cardboard carton with 159 kg (350 lb) bursting strength is adequate. Allow at least 3 to 4 inches on all sides of the analyzer for packing material.
6. Surround the equipment with three to four inches of packing material and prevent the equipment from moving in the carton. If packing foam is not available, the best alternative is S.D.-240 Air Cap™ from Sealed Air Corporation (Hayward, California, 94545). Air Cap looks like a plastic sheet filled with 1-1/4 inch air bubbles. Use the pink-colored Air Cap to reduce static electricity. Wrapping the equipment several times in this material should both protect the equipment and prevent it from moving in the carton.
7. Seal the shipping container securely with strong nylon adhesive tape.
8. Mark the shipping container “FRAGILE, HANDLE WITH CARE” to assure careful handling.
9. Retain copies of all shipping papers.

If You Have a Problem
How to Return Your Analyzer for Service