

# Keysight 16034G Test Fixture

Operation Manual

# Notices

© Keysight Technologies  
1999–2020

No part of this manual may be reproduced in any form or by any means (including electronic storage and retrieval or translation into a foreign language) without prior agreement and written consent from Keysight Technologies, Inc. as governed by United States and international copyright laws.

## Trademark Acknowledgments

## Manual Part Number

16034-90011

## Edition

Edition 8, December 2020

Printed in Malaysia

Published by:

Keysight Technologies International  
Japan G.K,  
1-3-3 Higashikawasaki-cho  
Chuo-ku  
Kobe-shi, Hyogo, Japan

## Warranty

THE MATERIAL CONTAINED IN THIS DOCUMENT IS PROVIDED “AS IS,” AND IS SUBJECT TO BEING CHANGED, WITHOUT NOTICE, IN FUTURE EDITIONS. FURTHER, TO THE MAXIMUM EXTENT PERMITTED BY APPLICABLE LAW, KEYSIGHT DISCLAIMS ALL WARRANTIES, EITHER EXPRESS OR IMPLIED WITH REGARD TO THIS MANUAL AND ANY INFORMATION CONTAINED HEREIN, INCLUDING BUT NOT LIMITED TO THE IMPLIED WARRANTIES OF MERCHANTABILITY AND FITNESS FOR A PARTICULAR PURPOSE. KEYSIGHT SHALL NOT BE LIABLE FOR ERRORS OR FOR INCIDENTAL OR CONSEQUENTIAL DAMAGES IN CONNECTION WITH THE FURNISHING, USE, OR PERFORMANCE OF THIS DOCUMENT OR ANY INFORMATION CONTAINED HEREIN. SHOULD KEYSIGHT AND THE USER HAVE A SEPARATE WRITTEN AGREEMENT WITH WARRANTY TERMS

COVERING THE MATERIAL IN THIS DOCUMENT THAT CONFLICT WITH THESE TERMS, THE WARRANTY TERMS IN THE SEPARATE AGREEMENT WILL CONTROL.

## Technology Licenses

The hardware and/or software described in this document are furnished under a license and may be used or copied only in accordance with the terms of such license.

## Declaration of Conformity

Declarations of Conformity for this product and for other Keysight products may be downloaded from the Web. Go to <http://www.keysight.com/go/conformity>. You can then search by product number to find the latest Declaration of Conformity.

## U.S. Government Rights

The Software is “commercial computer software,” as defined by Federal Acquisition Regulation (“FAR”) 2.101. Pursuant to FAR 12.212 and 27.405-3 and Department of Defense FAR Supplement (“DFARS”) 227.7202, the U.S. government acquires commercial computer software under the same terms by which the software is customarily provided to the public. Accordingly, Keysight provides the Software to U.S. government customers under its standard commercial license, which is embodied in its End User License Agreement (EULA), a copy of which can be found at

<http://www.keysight.com/find/sweula> The license set forth in the EULA represents the exclusive authority by which the U.S. government may use, modify, distribute, or disclose the Software. The EULA and the license set forth therein, does not require or permit, among other things, that Keysight: (1) Furnish technical information related to commercial computer software or commercial computer software documentation that is not customarily provided to the public; or (2) Relinquish to, or otherwise provide, the government rights in excess of these rights customarily provided to the public to use, modify, reproduce, release,

perform, display, or disclose commercial computer software or commercial computer software documentation. No additional government requirements beyond those set forth in the EULA shall apply, except to the extent that those terms, rights, or licenses are explicitly required from all providers of commercial computer software pursuant to the FAR and the DFARS and are set forth specifically in writing elsewhere in the EULA. Keysight shall be under no obligation to update, revise or otherwise modify the Software. With respect to any technical data as defined by FAR 2.101, pursuant to FAR 12.211 and 27.404.2 and DFARS 227.7102, the U.S. government acquires no greater than Limited Rights as defined in FAR 27.401 or DFARS 227.7103-5 (c), as applicable in any technical data.

## Safety Notices

### CAUTION

A **CAUTION** notice denotes a hazard. It calls attention to an operating procedure, practice, or the like that, if not correctly performed or adhered to, could result in damage to the product or loss of important data. Do not proceed beyond a CAUTION notice until the indicated conditions are fully understood and met.

### WARNING

A **WARNING** notice denotes a hazard. It calls attention to an operating procedure, practice, or the like that, if not correctly performed or adhered to, could result in personal injury or death. Do not proceed beyond a WARNING notice until the indicated conditions are fully understood and met.

Table of Contents

- 1. Overview
  - Product Overview . . . . . 5
  - Incoming Inspection . . . . . 6
  - Functions . . . . . 7
- 2. Operation
  - Performing Open and Short Correction . . . . . 9
    - Connecting the 16034G . . . . . 9
    - Performing Short Correction . . . . . 10
    - Performing Open Correction . . . . . 11
  - DUT Measurement . . . . . 12
    - DUT measurement over 3 MHz . . . . . 13
- 3. Specifications and Supplemental Performance Characteristics
  - Specifications . . . . . 15
  - Supplemental Performance Characteristics . . . . . 17
    - Frequency Range . . . . . 17
    - Additional Errors (With OPEN/SHORT correction) . . . . . 17
    - Contact Pressure . . . . . 19

## Contents

# 1 Overview

## Product Overview

The 16034G is designed for chip type components whose sizes range from 0201 to 1306. This test fixture can take measurements of the chip type L,C,R.

Figure 1-1 Product Overview



## Incoming Inspection

Inspect the shipping container for damage. If the shipping container or cushioning material is damaged, it should be kept until the contents of the shipment have been checked for completeness and the 16034G has been checked mechanically and electrically. The contents of the shipment should be as listed in **Table 1-1**. If the contents are incomplete, if there is mechanical damage or defect, notify the nearest Keysight Technologies office. If the shipping container is damaged, or the cushioning material shows signs of unusual stress, notify the carrier as well as the Keysight Technologies office. Keep the shipping materials for the carrier's inspection.

Table 1-1

### Contents

Description	Part Number	Qty.
16034G	-	1
100 W SMD Resistance	5012-8812	10
Case for 100 W SMD Resistance	1540-0692	1
Operation Manual	Option ABA <sup>a</sup>	1

a. The manual is furnished only Option ABA is ordered.

## Functions

Figure 1-2 16034G Parts

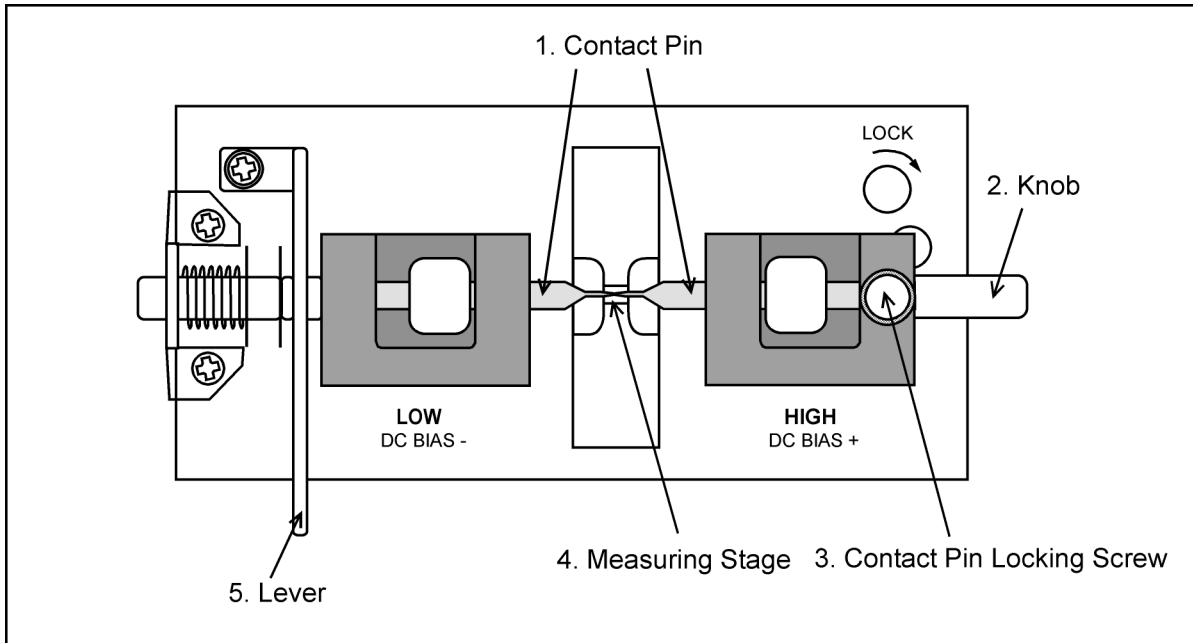

16034G0E01002

No.	Part	FUNCTION
1	Contact Pin	Contact for DUT electrode. LOW side Contact Pin connected to a instrument's $L_{CUR}$ , $L_{POT}$ and HIGH side Contact Pin connected to a instrument's $H_{CUR}$ , $H_{POT}$ .
2	Knob	For lateral adjustment of HIGH side Contact Pin.
3	Contact Pin Locking Screw	For securing HIGH side Contact Pin's position by turning clockwise.
4	Measuring Stage	Where DUT is mounted.
5	Lever	For pulling back Low side Contact Pin before placing DUT between contact pins.

Overview  
Functions



## 2 Operation

This chapter describes the proper methods for open and short correction and DUT measurement.

### Performing Open and Short Correction

To enhance measurement accuracy, open and short correction should be done before DUT measurement. The following procedure shows correction and measurement by the 16034G.

#### CAUTION

Take care to avoid rough handling and never allow any mechanical shock to the 16034G, especially against the contact pins from the sides or any to the parts mounted on top of the fixture.

---

#### Connecting the 16034G

1. Set the cable length to 0 m in the instrument.
2. Connect the 16034G directly to the UNKNOWN terminals as shown in **Figure 2-1**.

Operation  
Performing Open and Short Correction

Figure 2-1

Connecting the 16034G

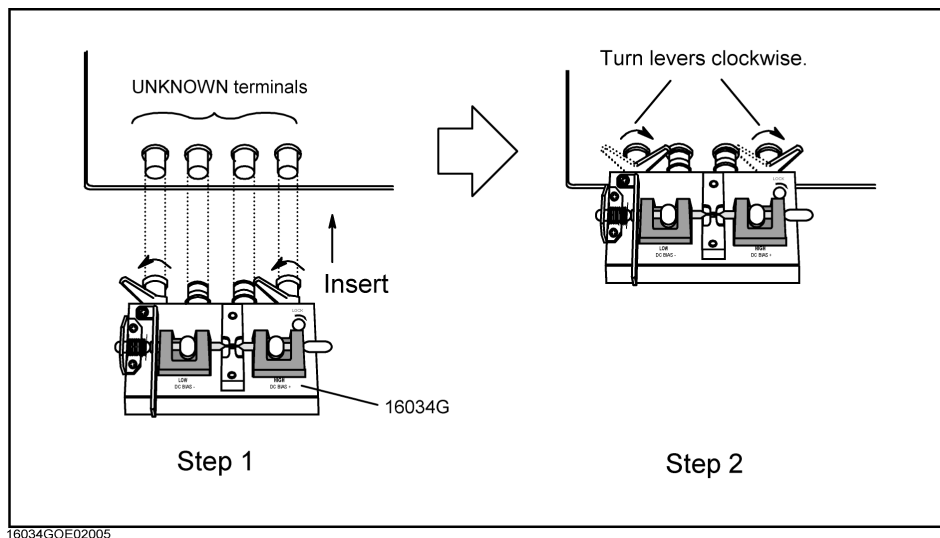

Performing Short Correction

The short correction procedure is as follows.

1. Push the HIGH side contact pin's knob to the left to make firm contact with the LOW side contact pin (Figure 2-2). Tighten the contact pin locking screw to secure the HIGH side contact pin.

Figure 2-2

Contact pin position for short correction

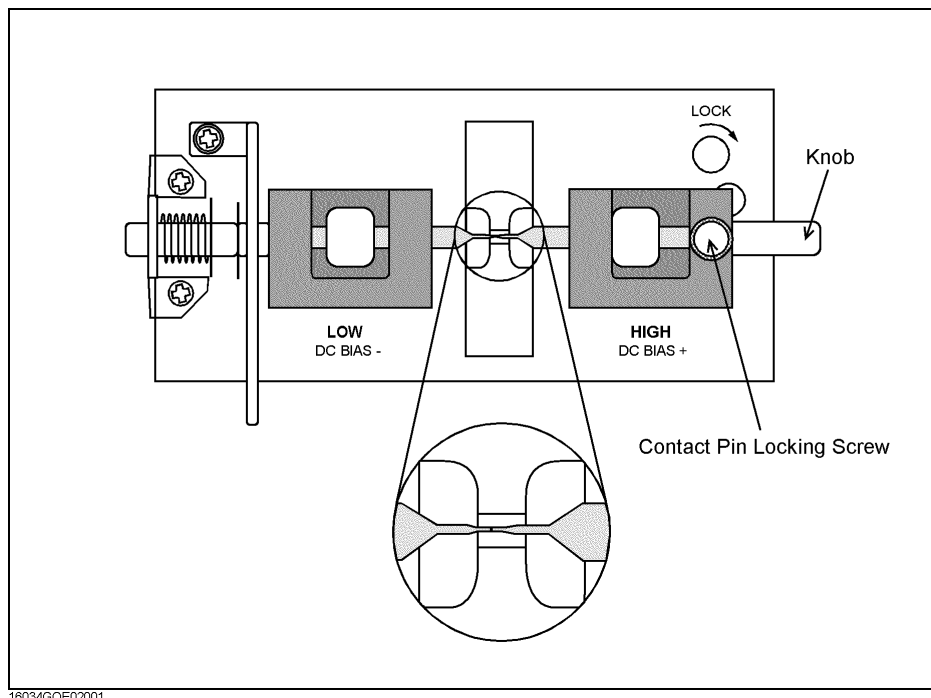

2. Perform the short correction as described in the specific instrument's manual.

## Performing Open Correction

The open correction procedure is as follows.

1. Push the HIGH side contact pin so that the distance between the HIGH and the LOW contact pins matches the DUT's width (**Figure 2-3**).

It is recommended that you place the DUT on the measuring stage and precisely position the HIGH side contact pin to actual DUT width.

### NOTE

Before performing open correction, remove the DUT used for positioning by pulling back the lever to release the LOW side contact pin.

2. Tighten the contact pin locking screw to secure the HIGH side contact pin.

Figure 2-3 Contact pin position for open correction

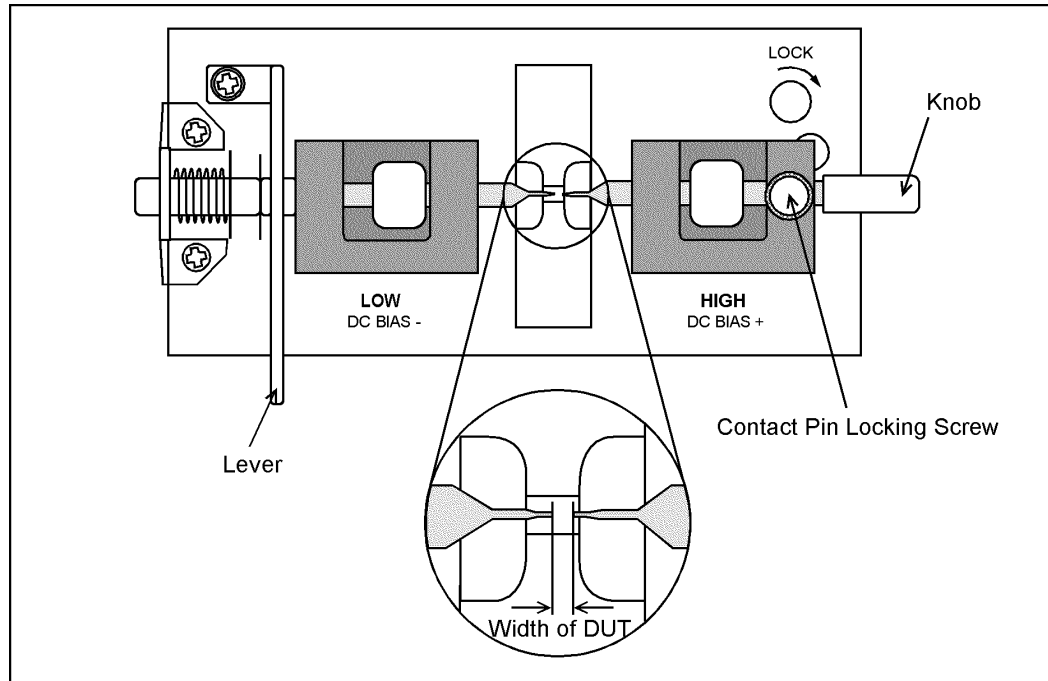

3. Perform the open correction as described in the specific instrument's manual.

## DUT Measurement

Before performing DUT measurement, open and short correction should be done as described in the previous sections. If measurement frequency is over 3 MHz, perform load correction before the DUT measurement described later onwards.

1. Adjust the HIGH side contact pin so that the DUT is positioned on the center of the measuring stage and secure the contact pin with the contact pin locking screw.
2. Release the LOW side contact pin with the lever and set the DUT on the measuring stage
3. Ease back slowly on the lever until the LOW side contact pin makes gentle contact with the DUT.

Figure 2-4 Contact pin position for DUT measurement

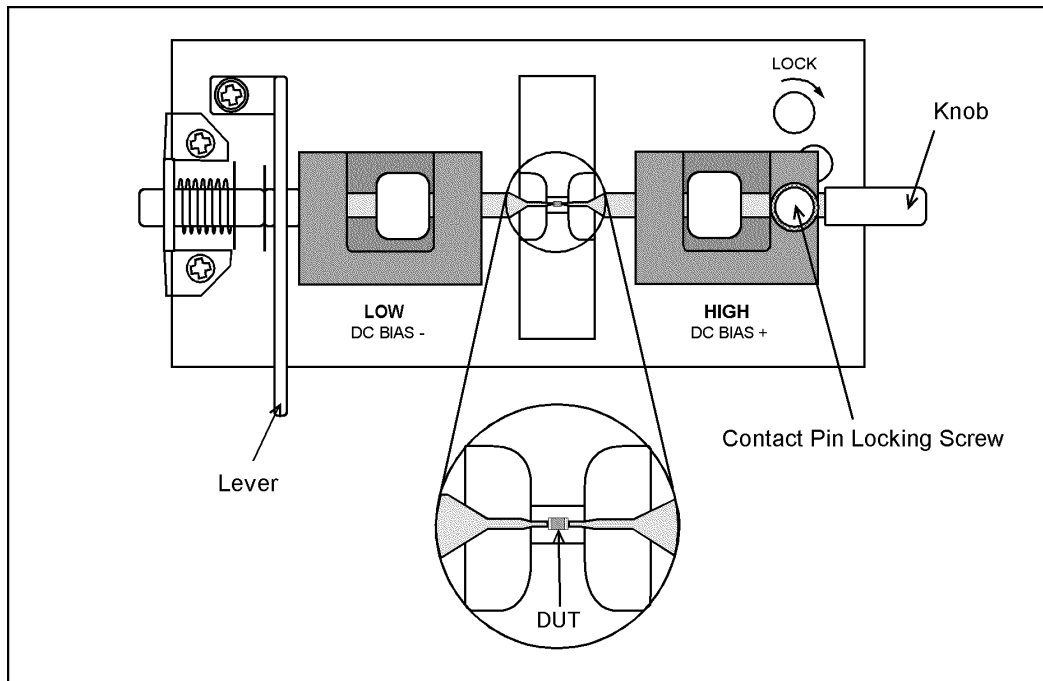

4. Perform the measurement as described in the specific instrument's manual.
5. To measure the same size DUT repeatedly, simply release the LOW side contact pin with the lever when to changing the DUT without moving the HIGH side contact pin.

**NOTE**

Measurement values can vary depending on contact pressure when measuring ferrite inductors or multi-layer ceramic capacitors with high permittivity. When measuring this kind of device, removing the E-ring can weaken the spring pre-load. However, this technique may increase contact resistance and thus degrades the accuracy of D parameter measurements.

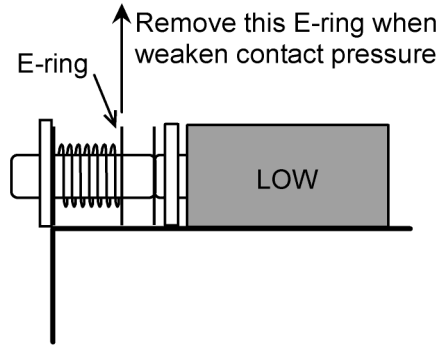

**NOTE**

Be sure to keep the contact pins clean at the points where they make contact with DUTs.

### DUT measurement over 3 MHz

Before performing DUT measurement over 3 MHz, performing load correction is recommended.

The proportional error factor in the additional error caused by the fixture is in proportion to the frequency squared. Therefore, the error increases greatly as the frequency goes high. To reduce this error, perform load correction.

1. Set the 100 W SMD resistor on the fixture the same way as a DUT measurement, and perform measurement at 3 MHz to determine the value of the 100 W SMD resistor.
2. Set the measured resistance and inductance values to the instrument as load value.
3. Perform load correction.

Operation  
DUT Measurement

### 3 Specifications and Supplemental Performance Characteristics

This chapter provides specifications and supplemental performance characteristics of the 16034G test fixture.

#### Specifications

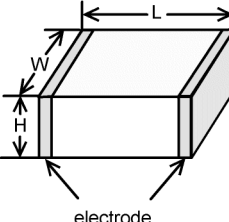
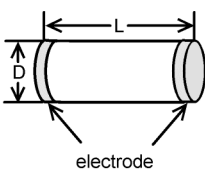
Applicable Instruments		LCR meters and impedance analyzers with four-terminals
Applicable DUT Type		Chip components
Applicable DUT dimensions		 <p> <math>0.3 \text{ mm} \leq H \leq 1.6 \text{ mm}</math>  <math>0.3 \text{ mm} \leq W \leq 1.6 \text{ mm}</math>  <math>0.1 \text{ mm} \leq L \leq 5.0 \text{ mm}</math> </p>  <p> <math>0.4 \text{ mm} \leq D \leq 1.6 \text{ mm}</math>  <math>0.1 \text{ mm} \leq L \leq 5.0 \text{ mm}</math> </p>
Maximum Voltage		$\pm 42 \text{ V}$ peak max. (AC+DC)
Operating Environment	temp.	0°C to +55°C
	humidity	15% to 95%RH (@ wet bulb temp. < 40°C)

Specifications and Supplemental Performance Characteristics  
Specifications

Non Operating Environment	temp.	- 40°C to +70°C
	humidity	≤ 90 % RH (@ wet bulb temp. < 65°C)
Dimensions	Approximately 120 (W) x 50 (H) x 70 (D) mm	
Weight	Approximately 200 g	



## Supplemental Performance Characteristics

This section provides useful data on the 16034G. These supplemental performance characteristics should not be considered specifications.

### Frequency Range

With OPEN/SHORT correction  $\leq 3$  MHz

With OPEN/SHORT/LOAD correction  $\leq 120$  MHz

### Additional Errors (With OPEN/SHORT correction)

Additional errors are calculated as follows.

#### **|Z| Measurement**

Additional error  $Z_e$  [%] of the  $|Z|$  measurement is calculated by substituting the values in the table below into the following equation.

$$Z_e \text{ [%]} = \pm \{A + (Z_s/Z_x + Y_o \times Z_x) \times 100\}$$

where

**A [%]** Additional Error (Proportional Error)

**Z<sub>s</sub> [ $\Omega$ ]** Short Repeatability (Impedance)

**Y<sub>o</sub> [S]** Open Repeatability (Admittance)

**Z<sub>x</sub> [ $\Omega$ ]** Measured Value (Impedance)

Z <sub>s</sub>	$\{10 + 13 \times (f / 10)\} \times 10^{-3}[\Omega]$
Y <sub>o</sub>	$\{5 + 500 \times (f / 10)\} \times 10^{-9}[\text{S}]$
A	$0.5 \times (f / 10)^2 \text{ [%]}$

where f is frequency (MHz).

#### **D Measurement**

Additional error  $D_e$  of the D measurement is calculated by additional error  $Z_e$  [%] of  $|Z|$  measurement as follows.

If  $D_x \leq 0.1$ :

$$D_e = Z_e / 100$$

If  $0.1 < D_x \leq 0.5$ :

$$D_e = (Z_e / 100) \times (1 + D_x)$$

where  $D_x$  is the measured value of  $D$ . It is necessary for  $Z_e$  to be below 10 %.

**NOTE**

$D$  is not expressed as a percentage but as an absolute value.

**$R_s$  (ESR) Measurement**

Additional error  $R_{se}[\%]$  of the  $R_s$  measurement is calculated by additional error  $Z_e [\%]$  of  $|Z|$  measurement as follows.

If  $D_x \leq 0.1$ :

$$R_{se} [\%] = Z_e / D_x$$

If  $0.1 < D_x \leq 0.5$ :

$$R_{se} [\%] = ( Z_e / D_x ) \times \sqrt{(1 + D_x^2)}$$

$D_x$  is the measured value of  $D$  and is calculated as follows.

$$D_x = 2 \times \pi \times f \times C_{sx} \times R_{sx},$$

where

$f$ : measurement signal frequency

$C_{sx}$ : measured value of  $C_s$

$R_{sx}$ : measured value of  $R_s$ .

Figure 3-1 Additional Error in  $|Z|$  measurement

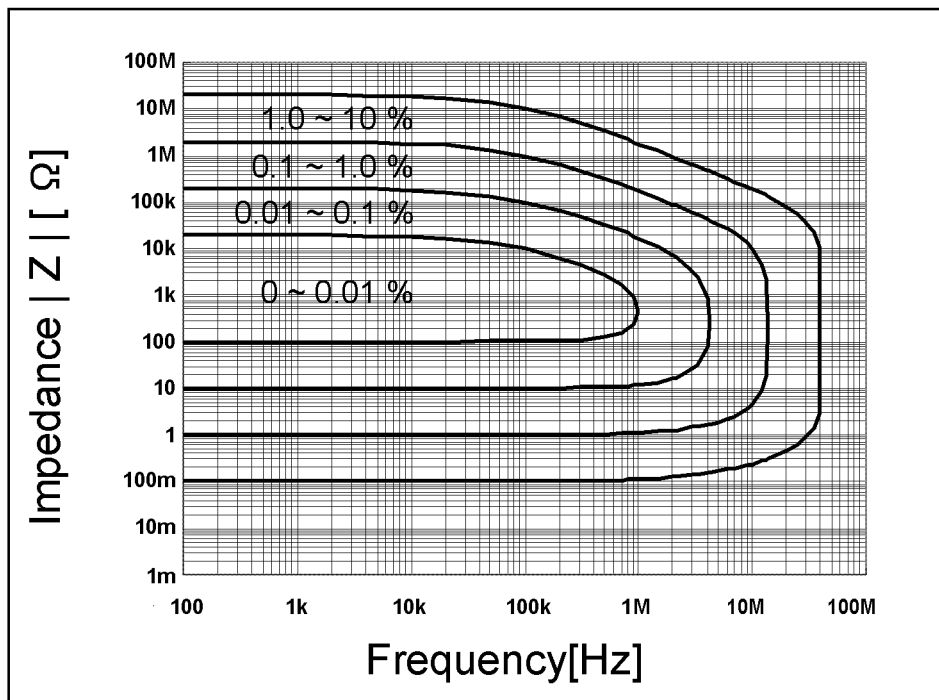

16034G0E03002

Specifications and Supplemental Performance Characteristics  
Supplemental Performance Characteristics

Contact Pressure

The following data are supplemental performance characteristics for the spring that applies contact pressure.

Spring constant	37 gf/mm $\pm$ 10 %
Spring pre-load	Approximately 400 g (without E-ring, approximately 20 g)

Specifications and Supplemental Performance Characteristics  
Supplemental Performance Characteristics

This information is subject to change without notice.

© Keysight Technologies 1999-2020

Edition 8, Decemeber 2020



16034-90011

[www.keysight.com](http://www.keysight.com)

