

34410A and 34411A Multimeters

Single-Mode/Multimode Fiber Lightwave Component Analyzer for 100G/400G/1T Electro-Optical Test (Arial 16pt)

Introduction

34410A 6½-digit high-performance DMM

- 10,000 readings/s @ 5½-digits direct to PC
- 1,000 readings/s @ 6½-digits direct to PC
- 30 PPM 1-year Basic DC accuracy
- LAN, USB & GPIB standard
- DCV, ACV, DCI, ACI, 2-wire and 4-wire Resistance, Frequency, Period, Continuity, and Diode Test
- Capacitance & Temperature measurements
- Expanded measurement ranges
- Data logger with 50 k reading non-volatile memory

34411A 6½-digit enhanced-performance DMM

All the features of the 34410A, plus:

- 50,000 readings/s @ 4½-digits direct to PC
- 1 million volatile reading memory
- Analog level triggering
- Programmable Pre/Post triggering



Product discontinuance notice

The 34410A/11A DMM and all associated options will be discontinued December 1, 2016. The last date this product can be ordered is November 30, 2016.

- For new product purchases, Keysight recommends the 34465A, 6½ digit Truevolt DMM.
- For more information, as well as to access to de-tailed migration guides, please visit <https://www.keysight.com/us/en/assets/7018-04838/technical-overviews/5992-0774.pdf>
- To contact a product selection expert, visit www.keysight.com/find/contactus

The Best Just Got Better

The Keysight Technologies, Inc. 34410A and 34411A 6½-Digit DMMs build on the phenomenal success of the industry-standard Keysight 34401A. These new meters offer improved accuracy, expanded measurement capability, dramatically improved measurement speed and throughput, and modern computer interfaces including LAN and USB. The dual display offers both dual measurement capabilities and ease of use when setting up and configuring the DMM. Improvements have been made in every facet of the 34401A to make the best even better, whether you use it on the bench or in a system.

Dramatic Speed Improvements

Whether it's raw reading speed or fast system throughput, the 34410A sets a new benchmark in performance. Using a new A/D technology, the 34410A achieves an impressive 10,000 readings a second at 5½-digits, and can stream readings to your computer at this same speed! Triggering is fast and precise, with both trigger latency and trigger jitter less than 1 µs, while bus query response is less than 500 µs. ACV measurements are faster as well thanks to a digital measurement technique that additionally improves accuracy at high and low frequencies. For even greater reading speeds, select the 34411A, which achieves 50,000 readings a second at 4½-digits.

Enhanced Measurement Performance

The 34410A and 34411A offer Temperature and Capacitance capabilities, in addition to those measurements you have come to expect, such as DCV, ACV, DCI, ACI, 2-wire and 4-wire Resistance, Frequency, Period, Continuity and Diode Test. You also get Offset Compensated Ohms, allowing you to accurately measure resistance in the presence of voltages. Measurement ranges have been expanded as well; for example, DC and AC Current Ranges now go down to 100 μ A, resulting in 100 pA resolution. Real-time math and statistics are included, and a peak-detect capability allows you to capture peaks as short as 20 μ s.

Even Greater Performance with the 34411A

The 34411A has all the features of the 34410A, plus additional performance that makes it even more powerful. With the ability to make 50,000 readings per second at 4 1/2 -digits, Analog Level Triggering, programmable Pre- and Post-Trigger and 1 million readings of volatile memory in addition to 50,000 reading of non-volatile memory, you now have the ability to capture low-frequency waveforms, characterize device performance and transfer results for analysis on your computer.

Data Logger Function

A front panel data logger function allows you to set the meter up to make unattended, paced measurements over a fixed time or number of events, then pull up the results later for review or transfer to a computer for analysis. Set the meter up to take measurements every 10 seconds for an hour, go have lunch, and check the results upon your return. The contextual front panel sequences make setup and read back a breeze.

Improved Ease of Use

From the inclusion of a second display to configuring setups for each of the measurement functions, these new DMMs offer significant improvements in usability. Simple things are simple; more complicated setups are easier than ever. There is even a new probe set designed to more easily probe today's fine-pitch components. Finally, there is a built-in Graphical Web Interface that allows you to interactively control the DMM without the hassle of programming at all!

Modern I/O for Improved Connectivity

When connecting to a computer, select LAN, USB or GPIB interfaces; all three are standard on the 34410A and 34411A. Concerned about the viability of your existing software programs? These new DMMs respond to Standard Commands for Programmable Instrumentation (SCPI), and there is even a 34401A Emulation Mode to ensure the easiest upgrade possible. Keysight's I/O Library Suite ships with the 34410A and 34411A to help you quickly establish an error-free connection between your PC and instrument. It provides robust instrument control and works with the software development environment you choose.

LXI – Class C

LAN Extensions for Instruments (LXI) provides the next generation I/O for system applications requiring the highest throughput. Transfer rates of over 250,000 readings/s are attainable ensuring even the most data intensive measurements are fast, without the overhead cost of an instrument cardcage. Both the 34410A and the 34411A are LXI – Class C compliant.

Built To Last

Our new DMMs were designed to high standards of ruggedness and reliability. From the robust package with its shock absorbing bumpers to careful selection of components and conservative circuit design, these meters are built to last. Calculated Mean Time Between Failure (MTBF) is in excess of 100,000 hours. Backed by a worldwide network of service centers, you can buy with confidence.

Go to the Web

For the latest information on these or other Keysight DMMs, go to <https://www.keysight.com/us/en/products/digital-multimeters-dmm.html>

Accessories Included:

- Test Lead Kit with probes and SMT attachments.
- Test report, power cord, and USB interface cable.

Product Reference CD-ROM with soft documentation and software:

- Programmer's Reference Help
- Quick Start Tutorial
- User's Guide
- Service Guide
- Programming Examples
- IntuiLink for Multimeters
- LabVIEW and IVI-COM drivers

Optional printed documentation:

- Quick Start Tutorial
- User's Guide
- Service Guide

Bench Dimensions:

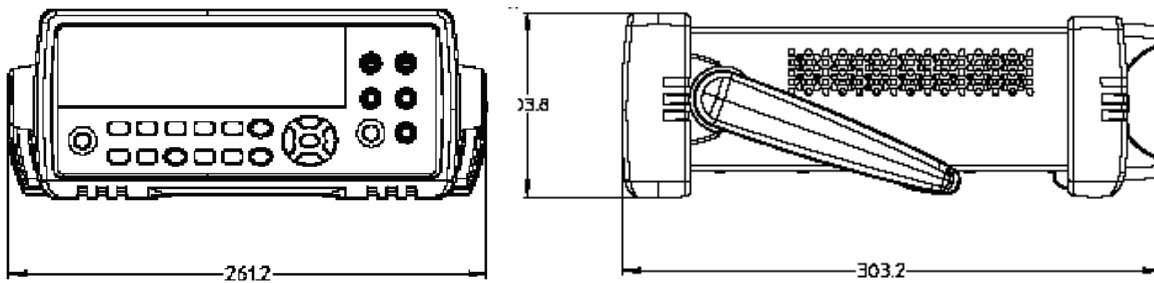

System Dimensions:

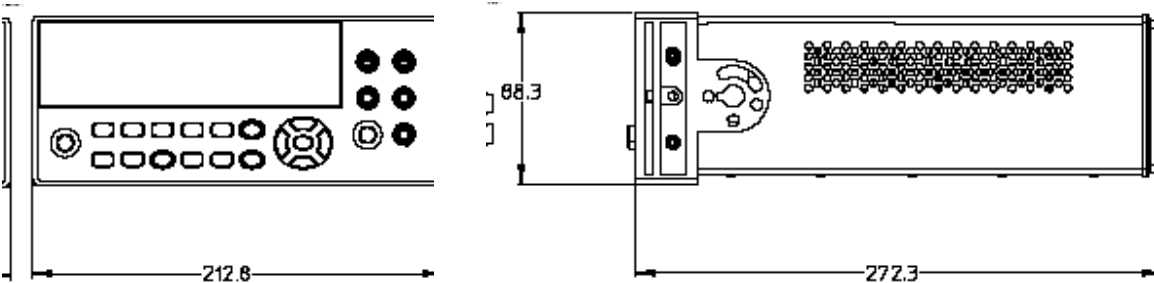

Accuracy Specifications ± (% of Reading + % of Range) ¹

| Function | Range ² | Frequency test current or burden voltage | 24 hour ³ Tcal ±1 °C | 90 day Tcal ±5 °C | 1 year Tcal ±5 °C | Temperature coefficient/°C 0 °C to (Tcal -5 °C) (Tcal +5 °C) to 55 °C |
|----------------------------------|---------------------------|--|------------------------------------|------------------------|------------------------|---|
| DC voltage | 100.0000 mV | | 0.0030 + 0.0030 | 0.0040 + 0.0035 | 0.0050 + 0.0035 | 0.0005 + 0.0005 |
| | 1.000000 V | | 0.0020 + 0.0006 | 0.0030 + 0.0007 | 0.0035 + 0.0007 | 0.0005 + 0.0001 |
| | 10.00000 V | | 0.0015 + 0.0004 | 0.0020 + 0.0005 | 0.0030 + 0.0005 | 0.0005 + 0.0001 |
| | 100.0000 V | | 0.0020 + 0.0006 | 0.0035 + 0.0006 | 0.0040 + 0.0006 | 0.0005 + 0.0001 |
| | 1000.000 V ⁴ | | 0.0020 + 0.0006 | 0.0035 + 0.0006 | 0.0040 + 0.0006 | 0.0005 + 0.0001 |
| True RMS AC voltage ⁵ | 100.0000 mV to 750.000 V | 3 Hz – 5 Hz | 0.50 + 0.02 | 0.50 + 0.03 | 0.50 + 0.03 | 0.010 + 0.003 |
| | | 5 Hz – 10 Hz | 0.10 + 0.02 | 0.10 + 0.03 | 0.10 + 0.03 | 0.008 + 0.003 |
| | | 10 Hz – 20 kHz | 0.02 + 0.02 | 0.05 + 0.03 | 0.06 + 0.03 | 0.005 + 0.003 |
| | | 20 kHz – 50 kHz | 0.05 + 0.04 | 0.09 + 0.05 | 0.10 + 0.05 | 0.010 + 0.005 |
| | | 50 kHz – 100 kHz | 0.20 + 0.08 | 0.30 + 0.08 | 0.40 + 0.08 | 0.020 + 0.008 |
| | | 100 kHz – 300 kHz | 1.00 + 0.50 | 1.20 + 0.50 | 1.20 + 0.50 | 0.120 + 0.020 |
| Resistance ⁶ | 100.0000 Ω | 1 mA | 0.0030 + 0.0030 | 0.008 + 0.004 | 0.010 + 0.004 | 0.0006 + 0.0005 |
| | 1.000000 kΩ | 1 mA | m0.0020 + 0.0005 | 0.007 + 0.001 | 0.010 + 0.001 | 0.0006 + 0.0001 |
| | 10.00000 kΩ | 100 μA | 0.0020 + 0.0005 | 0.007 + 0.001 | 0.010 + 0.001 | 0.0006 + 0.0001 |
| | 100.0000 kΩ | 10 μA | 0.0020 + 0.0005 | 0.007 + 0.001 | 0.010 + 0.001 | 0.0006 + 0.0001 |
| | 1.000000 MΩ | 5 μA | 0.0020 + 0.0010 | 0.010 + 0.001 | 0.012 + 0.001 | 0.0010 + 0.0002 |
| | 10.00000 MΩ | 500 nA | 0.0100 + 0.0010 | 0.030 + 0.001 | 0.040 + 0.001 | 0.0030 + 0.0004 |
| | 100.0000 MΩ | 500 nA 10 MΩ | 0.200 + 0.001 | 0.600 + 0.001 | 0.800 + 0.001 | 0.1000 + 0.0001 |
| | 1.000000 GΩ | 500 nA 10 MΩ | 2.000 + 0.001 | 6.000 + 0.001 | 8.000 + 0.001 | 1.0000 + 0.0001 |
| DC current | 100.0000 μA | < 0.3 V | 0.010 + 0.020 | 0.040 + 0.025 | 0.050 + 0.025 | 0.0020 + 0.0030 |
| | 1.000000 mA | < 0.3 V | 0.007 + 0.006 | 0.030 + 0.006 | 0.050 + 0.006 | 0.0020 + 0.0005 |
| | 10.00000 mA | < 0.3 V | 0.007 + 0.020 | 0.030 + 0.020 | 0.050 + 0.020 | 0.0020 + 0.0020 |
| | 100.0000 mA | < 0.3 V | 0.010 + 0.004 | 0.030 + 0.005 | 0.050 + 0.005 | 0.0020 + 0.0005 |
| | 1.000000 A | < 0.8 V | 0.050 + 0.006 | 0.080 + 0.010 | 0.100 + 0.010 | 0.0050 + 0.0010 |
| | 3.000000 A | < 2.0 V | 0.100 + 0.020 | 0.120 + 0.020 | 0.150 + 0.020 | 0.0050 + 0.0010 |
| True RMS AC Current ⁷ | 100.0000 μA to 3.000000 A | 3 Hz – 5 kHz | 0.10 + 0.04 | 0.10 + 0.04 | 0.10 + 0.04 | 0.015 + 0.006 |
| | | 5 kHz – 10 kHz | 0.20 + 0.04 | 0.20 + 0.04 | 0.20 + 0.04 | 0.030 + 0.006 |
| Frequency or Period | 100 mV to 750 V | 3 Hz – 5 Hz | 0.070 + 0.000 | 0.070 + 0.000 | 0.070 + 0.000 | 0.005 + 0.000 |
| | | 5 Hz – 10 Hz | 0.040 + 0.000 | 0.040 + 0.000 | 0.040 + 0.000 | 0.005 + 0.000 |
| | | 10 Hz – 40 Hz | 0.020 + 0.000 | 0.020 + 0.000 | 0.020 + 0.000 | 0.001 + 0.000 |
| | | 40 Hz – 300 kHz | 0.005 + 0.000 | 0.006 + 0.000 | 0.007 + 0.000 | 0.001 + 0.000 |
| Capacitance ⁸ | 1.0000 nF | 500 nA | 0.50 + 0.50 | 0.50 + 0.50 | 0.50 + 0.50 | 0.05 + 0.05 |
| | 10.000 nF | 1 μA | 0.40 + 0.10 | 0.40 + 0.10 | 0.40 + 0.10 | 0.05 + 0.01 |
| | 100.00 nF | 10 μA | 0.40 + 0.10 | 0.40 + 0.10 | 0.40 + 0.10 | 0.01 + 0.01 |
| | 1.0000 μF | 10 μA | 0.40 + 0.10 | 0.40 + 0.10 | 0.40 + 0.10 | 0.01 + 0.01 |
| | 10.000 μF | 100 μA | 0.40 + 0.10 | 0.40 + 0.10 | 0.40 + 0.10 | 0.01 + 0.01 |
| Temperature ⁹ | RTD | -200 °C to 600 °C | 0.06 °C | 0.06 °C | 0.06 °C | 0.003 °C |
| | Thermistor | -80 °C to 150 °C | 0.08 °C | 0.08 °C | 0.08 °C | 0.002 °C |
| Continuity | 1000.0 Ω | 1 mA | 0.002 + 0.010 | 0.008 + 0.020 | 0.010 + 0.020 | 0.0010 + 0.0020 |
| Diode Test ¹⁰ | 1.0000 V | 1 mA | 0.002 + 0.010 | 0.008 + 0.020 | 0.010 + 0.020 | 0.0010 + 0.0020 |

¹ Specifications are for 90 minutes warm-up and 100 PLC

² 20% overrange on all ranges, except DCV 1000 V, ACV 750 V, DCI and ACI 3 A ranges

³ Relative to calibration standards

⁴ For each additional volt over ±500 V add 0.02 mV of error

⁵ Specifications are for sinewave input > 0.3% of range and > 1 mVrms. Add 30 μV error for frequencies below 1 kHz. 750 VAC range limited to 8 x 10⁷ Volts-Hz. For each additional volt over 300 Vrms add 0.7 mVrms of error.

⁶ Specifications are for 4-wire resistance measurements, or 2-wire using Math Null. Without Math Null, add 0.2 Ω additional error in 2-wire resistance measurements.

⁷ Specifications are for sinewave input > 1% of range and > 10 μArms. Frequencies > 5 kHz are typical for all ranges. For the 3 A range (all frequencies) add 0.05% of reading + 0.02% of range to listed specifications.

⁸ Specifications are for 1-hour warm-up using Math Null. Additional errors may occur for non-film capacitors.

⁹ For total measurement accuracy, add temperature probe error

¹⁰ Accuracy specifications are for the voltage measured at the input terminals only. 1 mA test current is typical. Variation in the current source will create some variation in the voltage drop across a diode junction.

A-to-D converter noise performance

| Integration time (NPLC) | Resolution (ppm of range) ¹ | Normal mode rejection (dB) ² | Readings/second ³ |
|-------------------------|--|---|------------------------------|
| 0.001 ⁴ | 30 | 0 | 50,000 |
| 0.002 ⁴ | 15 | 0 | 25,000 |
| 0.006 | 6 | 0 | 10,000 |
| 0.02 | 3 | 0 | 3,000 |
| 0.06 | 1.5 | 0 | 1,000 |
| 0.2 | 0.7 | 0 | 300 |
| 1 | 0.3 | 55 | 60 (50) |
| 2 | 0.2 | 110 ⁵ | 30 (25) |
| 10 | 0.1 | 110 ⁵ | 6 (5) |
| 100 | 0.03 | 110 ⁵ | 0.6 (0.5) |

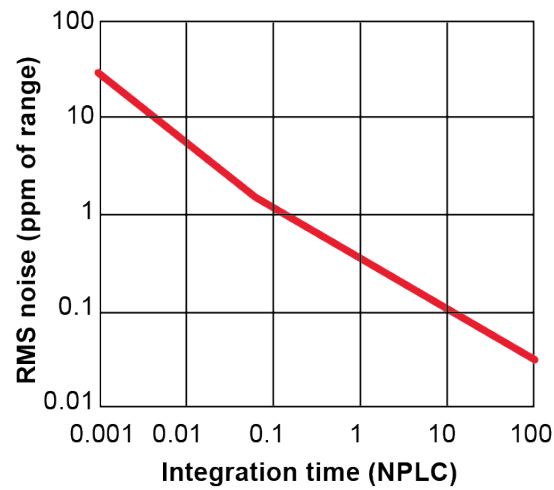

Integration time (NPLC)

¹ Resolution is defined as the typical DCV 10 V range RMS noise. Auto-zero on for NPLC ≥ 1 . See manual for additional noise characteristics.

² Normal mode rejection for power line frequency $\pm 0.1\%$

³ Maximum rate with auto-zero off for 60 Hz and (50 Hz) operation

⁴ Only available for the 34411A

⁵ For power-line frequency $\pm 1\%$ 75 dB and for $\pm 3\%$ 55 dB

System reading and throughput rates

DMM memory to PC (maximum reading rate out of memory) ¹

Drawing – Path B

| Reading format | GPIB readings/s | USB 2.0 readings/s | LAN (VXI-11) readings/s | LAN (sockets) readings/s |
|----------------|-----------------|--------------------|-------------------------|--------------------------|
| ASCII | 4,000 | 8,500 | 7,000 | 8,500 |
| 32-bit binary | 89,000 | 265,000 | 110,000 | 270,000 |
| 64-bit binary | 47,000 | 154,000 | 60,000 | 160,000 |

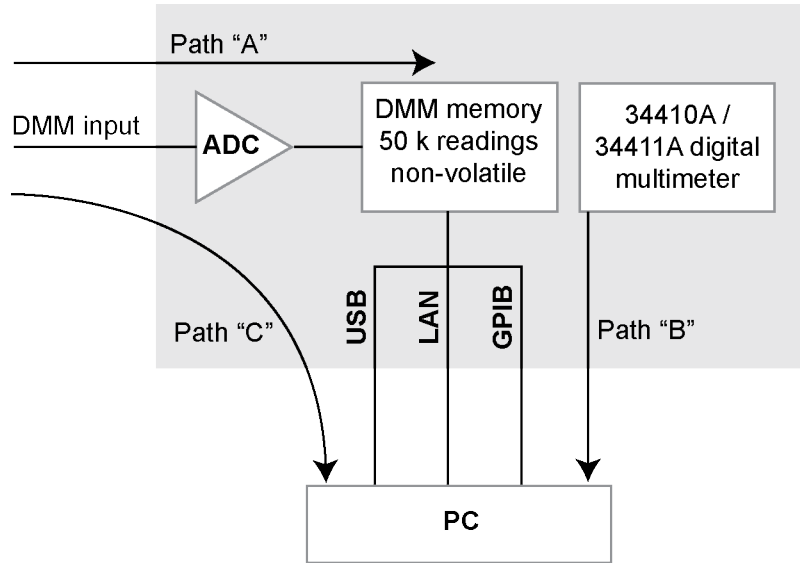

System reading architecture

Direct I/O Measurements (single reading – measure and I/O time) ¹

Drawing – Path B

| Function | Resolution (NPLC) | GPIB ms | USB 2.0 ms | LAN (VXI-11) ms | LAN (sockets) ms | Maximum reading rate into memory or to direct I/O (readings/s) drawing – path A or C |
|-------------------------|-----------------------|---------|------------|-----------------|------------------|--|
| DCV / 2-wire resistance | 0.006 (0.001) | 2.6 | 2.9 | 4.6 | 3.2 | 10,000 (50,000) |
| ACV / frequency | Fast Filter 1 ms gate | 10.0 | 10.0 | 10.0 | 10.0 | 500 |

¹ 1/2 scale input signal, immediate trigger, trigger delay 0, auto-zero off, auto-range off, no math, null off, 60 Hz line frequency. Specifications are for 34410A or (34411A). See manual for performance on other functions.

System performance

| | Function change (ms) ¹ | Range change (ms) LAN/GPIB ² | Auto-range (ms) ³ | Maximum external trigger rate | Maximum internal trigger rate ⁴ |
|-------------------------|-----------------------------------|---|------------------------------|-------------------------------|--|
| DCV / 2-wire resistance | 22 | 3.9/2.6 | 7.5 | 5,000/s | 10,000/s (50,000/s) |
| ACV / Frequency | 37 | 6.5/6.4 | 19 | 500/s | 500/s |

Measurement Characteristics

DC voltage

Measurement method:

continuously integrating multi-slope IV A/D converter

Linearity:

0.0002% of reading

10 V range:

+0.0001% of range

Input resistance:

0.1 V, 1 V, 10 V 10 MΩ or > 10 GΩ

Ranges (selectable)

100 V, 1000 V 10 MΩ ±1%

Ranges (fixed)

Input bias current:

< 50 pA at 25 °C

Input protection:

1000 V

DC CMRR:

140 dB⁵

¹ Time to change from 2-wire Resistance to this specified function, or DCV to 2-wire Resistance using the SCPI "FUNC" command.

² Time to change from one range to the next higher range, ≤ 10 V, ≤ 10 MΩ.

³ Time to automatically change one range and be ready for the new measurement, ≤ 10 V, ≤ 10 MΩ.

⁴ Specifications are for 34410A or (34411A).

⁵ For 1 kΩ unbalanced in LO lead, ±500 V peak maximum

True RMS AC voltage

Measurement method:

AC-coupled True RMS measurement. Digital sampling with anti-alias filter.

Crest factor:

No additional error for crest factors < 10. Limited by peak input and 300 kHz bandwidth.

Peak input:

300% of range or 1100 V

Overload ranging:

Will select higher range if peak input overload is detected during auto range. Overload is reported in manual ranging.

AC CMR:

70 dB ¹

Maximum input:

400 Vdc, 1100 Vpk

Input impedance:

1 M Ω \pm 2% in parallel with < 150 pF

Input protection:

750 Vrms all ranges

Resistance

Measurement method:

Selectable 2-wire or 4-wire. Current source referenced to LO input.

Offset compensation:

Selectable on the 100 Ω , 1 k Ω , and 10 k Ω ranges

Max. lead resistance (4-wire):

10% of range per lead for 100 Ω , 1 k Ω . 1 k Ω per lead on all other ranges

Input protection:

1000 V on all ranges

¹ For 1 k Ω unbalanced in LO lead and < 60 Hz, \pm 500 V peak maximum

DC current

Current shunt:

200 Ω for 100 μ A, 1 mA

2 Ω for 10 mA, 100 mA

0.1 Ω for 1 A, 3 A

Input protection:

3 A, 250 V fuse

True RMS AC current

Measurement method:

AC-coupled True RMS measurement. Directly coupled to the fuse and shunt. Digital sampling with anti-alias filter.

Current shunt:

200 Ω for 100 μ A, 1 mA

2 Ω for 10 mA, 100 mA

0.1 Ω for 1 A, 3 A

Maximum input:

The peak value of the DC + AC current must be < 300% of range. The RMS current must be < 3 A including the DC current content.

Input protection:

3 A, 250 V fuse

Frequency and period

Measurement method:

Reciprocal-counting technique. AC-coupled input using the AC voltage measurement function.

Input impedance:

1 M Ω \pm 2% in parallel with < 150 pF

Input protection:

750 V_{rms} all ranges

Capacitance

Measurement method:

Current input with measurement of resulting ramp.

Connection type:

2-wire

Temperature

Thermistor:

2.2 k Ω , 5 k Ω , and 10 k Ω

RTD:

$\alpha = 0.00385$

R₀ from 49 Ω to 2.1 k Ω

Continuity/diode test

Response time:

300 samples/sec with audible tone

Continuity threshold:

Fixed at 10 Ω

Operating characteristics maximum readings/second

| | Digits | | |
|-----------------------|-------------------|------|------|
| Function ¹ | 4.5 | 5.5 | 6.5 |
| DCV | 50 k ² | 10 k | 1 k |
| 2-wire Ω | 50 k ² | 10 k | 1 k |
| DCI | 50 k ² | 10 k | 1 k |
| Frequency | 500 | 90 | 10 |
| Period | 500 | 90 | 10 |
| Filter setting | fast | med | slow |
| ACV | 500 | 150 | 50 |
| ACI | 500 | 150 | 50 |

¹ Maximum rate for DCV, DCI, and resistance functions (using zero settling delay, autozero off, manual range)

² 34411A only

Additional 34411A specifications

Resolution:

See table on page 6

Overall Bandwidth, DCV & DCI:

15 kHz typical @ 20 μ s aperture (-3 dB)

Triggering:

Pre/Post, Int/Ext, Pos/Neg

Timebase resolution:

19.9524 μ s 0.01% accuracy

Trigger Jitter:

2 μ s (p-p), 20 μ s (p-p) when pre-triggered

Spurious-free dynamic range & signal to noise distortion ratio

| Function DCV | Range | Spur-free | SNDR |
|--------------|-------------------|-----------|-------|
| | 1 V | -75 dB | 60 dB |
| | 10 V ¹ | -70 dB | 60 dB |
| | 100 V | -75 dB | 60 dB |

¹ 10 V range: 2 V (p-p) < signal < 16 V (p-p)

Triggering and memory

Reading hold sensitivity:

1% of reading

Samples per trigger:

1 to 50,000 (34410A)

1 to 1,000,000 (34411A)

Trigger delay:

0 to 3600 s (20 μ s step size)

External trigger:

Programmable edge, low-power TTL compatible

Delay:

< 1 μ s

Jitter:

< 1 μ s

Max rate:

5,000/s

Min pulsewidth:

1 μ s

Voltmeter complete:

3 V Logic output, 2 μ s pulse with programmable edge

Nonvolatile memory:

50,000 readings

Volatile memory:

50,000 readings (34410A)

1,000,000 readings (34411A)

Sample timer

Range: 0 to 3600 s (20 μ s step sizes)

Jitter: < 100 ns

General specifications

Power supply:

100 V/120 V/220 V/240 V \pm 10%

Power line frequency:

45 Hz to 66 Hz and 360 Hz to 440 Hz, Automatically sensed at power-on

Power consumption:

25 VA peak (16 W average)

Operating environment:

Full accuracy for 0 °C to 55 °C, 80% R.H. at 40 °C non-condensing

Storage temperature:

-40 °C to 70 °C

Weight:

3.72 kg (8.2 lbs)

Safety:

IEC 61010-1, EN 61010-1, UL 61010-1, CAN/CSA-C22.2 No. 61010-1, Refer to Declarations of Conformity for current revisions. Measurement CAT II 300 V, CAT I 1000 V. Pollution Degree 2

EMC:

IEC 61326, EN 61326, CISPR 11, ICES-001, AS/NZS 2064.1, Refer to Declaration of Conformity for current revisions.

Vibration & shock:

MIL-T-28800E, Type III, Class 5 (Sine Only)

LXI compliance:

LXI Class C, ver. 1.0

Warranty:

3 year standard

Ordering Information

Keysight 34410A and 34411A multimeters

| | |
|---|--|
| Accessories included | Test lead kit with probes and SMT attachments, calibration certificate, power cord, and USB interface cable |
| Product reference CD with soft documentation and software | <ul style="list-style-type: none">• Programmer's reference help• Quick start tutorial• User's guide• Service guide• Programming examples• IntuiLink for multimeters• LabVIEW and IVI-COM drivers |
| Options | |
| Opt. A6J | ANSI Z540 compliant calibration |
| Probes/leads/clip accessories | |
| 11059A | Kelvin probe set |
| 11060A | Surface mount device (SMD) test probes |
| 11062A | Kelvin clip set |
| 34133A | Precision electronic test leads |
| 34134A | DC coupled current probe |
| 34136A | High voltage probe |
| 34138A | Test lead set |
| 34171B | Input terminal connector (sold in pairs) |
| 34172B | Input calibration short (sold in pairs) |
| 34308A | Thermistor kit |
| 34330A | 30 A current shunt |
| E2308A | 5 k thermistor probe |
| Y1133A | Low-thermal external digital multimeter scanning kit |
| Rack mount kits | |
| 34190A | Rackmount kit: designed for use with only one instrument, mounted on either the left or the right side of the rack |
| 34191A | 2U dual flange kit: secures the instrument to the front of the rack. This kit can be used with the 34194A dual lock link kit to mount two half-width, 2U height instruments side-by-side. |
| 34194A | Dual lock link kit: recommended for side-by-side combinations and includes links for instruments of different depths. This kit can be used with the 34191A 2U dual flange kit to mount two half-width, 2U height instruments side-by-side. |
| Other accessories | |
| 34131A | Hard transit case |
| 34162A | Accessory pouch |
| E5810A | LAN/GPIB gateway |

<https://www.keysight.com/us/en/products/digital-multimeters-dmm.html>

For more information on Keysight Technologies' products, applications, or services, please visit: www.keysight.com



This information is subject to change without notice. © Keysight Technologies, 2013 - 2022, Published in USA, July 12, 2022, 5989-3738EN