

Scienlab Dynamic DC Emulator

High-Power Series – Up to 360 kW

SL1042A



Table of Contents

System Overview	3
System Options	8
Cabinet base option class	8
SL1042A-701 Base stand	8
SL1042A-702 Rollers	8
Interface options beyond Ethernet.....	8
SL1042A-030 Additional EtherCat interface	8
Project Management, Consulting and Installation Services	9
PS-XPM-100-SL Project management services	9
PS-XINS-100-SL Project installation services	9
PS-XENG-100-SL Project engineering services.....	9
PS-XCOM-100-SL Project commissioning services	9
PS-S40-03 Productivity assistance.....	10
Extend the Capabilities of your Test Solution	10

System Overview

The Scienlab Dynamic DC Emulator (DCE) is an electric system designed to emulate batteries or other components for automotive applications.

With bi-directionality, integrated DC voltage and current controllers, high dynamics, and its regenerative energy feedback capacity, the Scienlab Dynamic DC Emulator provides an all-in-one system for efficient and effective testing of the power electronic components in electric vehicles (EV) and electric vehicle supply equipment (EVSE).

- Efficient testing of power electronics and charging technology
- Available for high voltage
- Energy-efficient source and sink mode
- Real-time-capable, open interface
- Power increase through parallelization

The following voltage, current and power options are available:

Voltage	50 to 600 V		50 to 850 V			50 to 1000 V			
Current options	600 A		300 A	600 A		300 A		600 A	
Power options	250 kW	300 kW	250 kW	250 kW	300 kW	250 kW	300 kW	250 kW	300 kW
	330 kW	360 kW		330 kW	360 kW			330 kW	360 kW

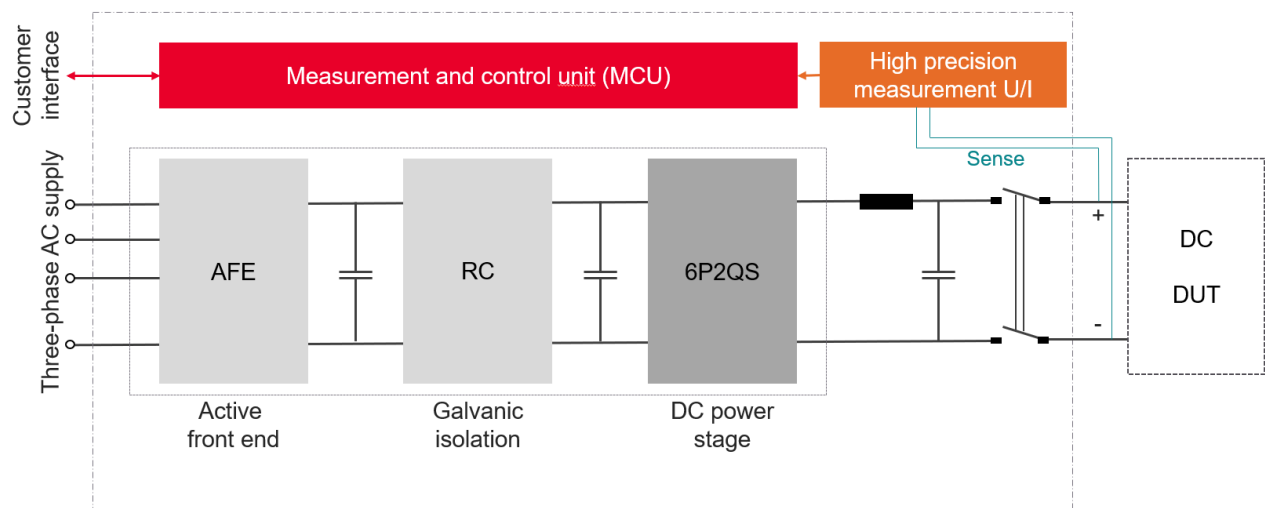

Figure 1. Scienlab Dynamic DC Emulator system block diagram.

Note: The Scienlab DCE High-Power Series can be controlled with Scienlab Emulator Control which is included in the position Machine Emulator.

Controller unit with power stage

Measurement and Control Unit (MCU) real-time control module provides:

- Real-time computer controlling electrical output variables
- RLC simulation model
- Communication interface: Ethernet, incl. software interface description

Integrated battery model as per following equivalent circuit diagram:

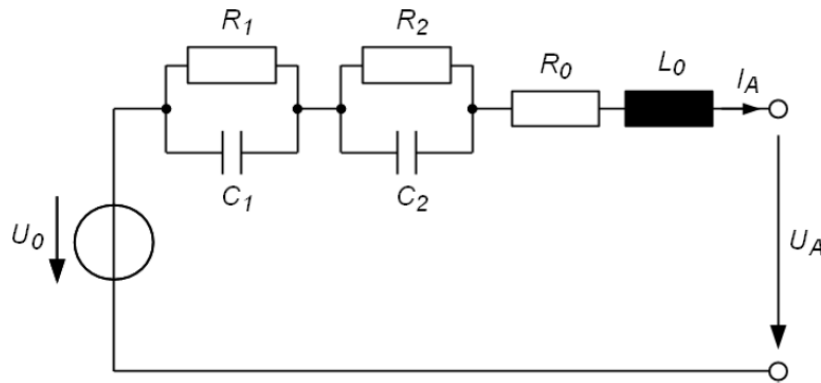

Figure 2. Battery model.

The model shall only be active in voltage source operation.

Customer-settable parameters:

- U_0 : Nominal voltage source value [V]
- R_0 : Internal voltage source resistance [Ω]
- R_1 : Resistance within 1st RC link [Ω]
- C_1 : Capacity within 1st RC link [F]
- R_2 : Resistance within 2nd RC link [Ω]
- C_2 : Capacity within 2nd RC link [F]
- L_0 : Internal inductance [H]

Analog acquisition of voltage and current measuring (4-wire measurement)

Voltage	600 V	850 V	1000 V
Voltage accuracy ¹	$\pm 0.05\%$ of measured value, ± 200 mV (offset)		$\pm 0.05\%$ of measured value, ± 300 mV (offset)

¹ Measurement and programming accuracy

Current	300 A	600 A
Current accuracy ¹	$\pm 0.05\%$ of measured value, ± 60 mA (offset)	$\pm 0.05\%$ of measured value, ± 120 mA (offset)

¹ Measurement and programming accuracy

- Resolution: 32 bits
- Sample rate: max. 20 kS/s (internal 625 kS/s)
- DC measure and control accuracy are the same
- Recommended re-calibration period: 12 months

Note: Connecting two systems in parallel has no effect on the voltage accuracy. The offset of the current accuracy is multiplied by two. The error of the measured value [%] is not affected.

Output characteristics

Voltage	300 A	600 A
Voltage ripple	300 mV _{eff} typ., 500 mV _{eff} max. at measuring range of 500 kHz	
Output capacity	1600 µF (800 µF optional ¹)	3200 µF (1600 µF optional ¹)
Load stability	< 80 V (typ. < 40 V @ 400 V, 0 → 250 A < 1 ms, 400 µF	< 80 V (typ. < 40 V @ 400 V, 0 → 500 A < 1 ms, 400 µF

¹ For changing the output capacity please refer to operation instructions.

Explanation of load stability

- @ 400 V → output voltage of 400 V
- 0 → 250 A, < 1 ms → current rise from 0 A to 250 A in less than 1 ms
- 400 µF → load capacity (typical DUT input capacity)
- typically 40 V → average overvoltage of 40 V
- < 80 V → maximum 80 V overvoltage/undervoltage

Regenerative power stage

- Modular rack-mounted system, easy to maintain
- The default current and voltage ranges are shown in Figure 3 (2 quadrant system)

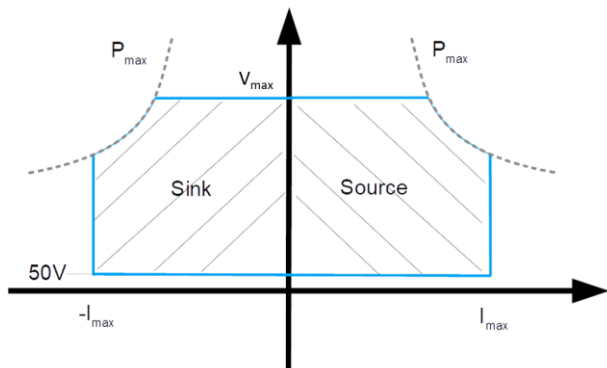

Figure 3. Max. power of 50 V to V_{max} (2 quadrant system).

Intrinsic safety

- Built-in safeguards against overheating, overcapacity, short circuit and idling
- Protection against reverse polarity by monitoring the polarity secured by software
- No hardware protection against reverse polarity before output contactors have been closed
- Monitoring of all internal voltages, currents and temperatures
- DC output contactors capable of disconnecting at full load current
- Mains side power contactors ensuring the absence of voltage
- Discharge of all internal high voltage sources upon emergency stop

System cabinet	
Basic dimensions (H x W x D)	2.4 m x 3.6 m x 0.8 m placed on rollers plus overlap by switches etc.
Weight	2000 to 2300 kg
Protection class	IP 54
Control cabinet color	RAL 7035
Ambient temperature	10 to 40 °C
Air humidity	30 to 75% rel. H.
Sound pressure level	according to DIN EN 3744 < 70 dB(A), measured at 1 m distance from front

Documentation

- Operating instructions in English
- CE Declaration of Conformity
- Acceptance and calibration protocol

Active Front End (AFE)

- Regenerative
- Mains recovery (eff. > 90%)
- Idle power compensation $\cos(\varphi) > 0.98$
- HF EMC filter
- 2 kHz filter
- Proof of limits having been respected for line-bound failures within low voltage mains as per EN61000-6-4:2007

Resonance converter

- All-pole isolation of power stages to supply mains

Mains supply

- 3, PE 400 V (+10%/-5%), 50 Hz (± 0.2 Hz)
- Functional earth (FE)
- Roof-top cable routing with EMC screw connection

System	250 kW	300 kW	330 kW	360 kW
Back-up fusing provided by customer	2x 224 A gG	2x 315 A gG	2x 315 A gG	2x 315 A gG

Power electronics cooling

- Water/water heat exchanger with internal water circuit to ensure dew protection
- Limitation of the water amount inside of the cabinet
- Monitoring of water temperature and internal controller
- Metal jacketed cooling water hoses

System cooling

System	250 kW	300 kW	330 kW	360 kW
Max. heat discharge	25 kW	30 kW	33 kW	36 kW
Throughput (full load) ($\vartheta_Z = 15\text{ °C}$, $\vartheta_R = 30\text{ °C}$, $\Delta\vartheta = 15\text{ K}$)	0.39 l/s (1.43 m ³ /h)	0.47 l/s (1.7 m ³ /h)	0.52 l/s (1.89 m ³ /h)	0.57 l/s (2.0 m ³ /h)

- Temperature of supply flow: 1 “, $\vartheta_Z = 6$ to 20 °C
- Temperature of return flow: 1 “, $\vartheta_R = \text{max. } 30\text{ °C}$
- Max. input pressure 6 bar, without pressure, differential pressure: 1.5 to 3.0 bar
- Flow control meeting the specific demands
- Water stop valve

Safety

- Shut down for emergency stop: U = 0 V or I = 0 A selectable
- Emergency stop-delay adjustable between 0 to 30 s
- Emergency stop/ main switch for all-pole disconnection
- Fast stop push button
- External fast stop input for Test Bench Guard integration
- Key switch for enabling the output contactors
- Door hinge mounted on the right side
- Door handles: Comfort handles with safety lock
- Parameterizable limits for the protection of the device under test
- Insulation guard monitor
- Evaluation of the insulation resistance via interface
- Insulation guard can be switched off

Note: If the insulation guard is switched off, a separate insulation guard must be available at the test item and is integrated in the emergency chain. The customer is then responsible for the safety of the test bench by himself.

Display elements		
Signal light on the control cabinet with magnetic base	Red	Error
	Yellow	Operation
	Green	Ready for operation
Indicators	Power coil instrument in front door to indicate the terminal output voltage: 0 to 1000 V	

Interface to the supervisory system on the terminal block:

- Enabling of network side contactors
- Enable output contactors
- Signal output contact open/closed
- Message of limit value violation
- Message sums error
- Emergency stop message
- Release system
- Emergency stop input

Test Bench Guard ready – High-Power DC Emulator

The Test Bench Guard (SL1020A) can be used as an additional device because it manages the emergency stop signals and several external signals. The cut-out scenarios are defined by a safety matrix.

System Options

Cabinet base option class

SL1042A-701 Base stand

Control cabinet is placed on top of a 15 cm high base stand.
(total height including base stand: 2.38 m)

SL1042A-702 Rollers

Control cabinet stands on top of 25 cm high rollers and can be moved.
(total height including rollers: 2.48 m)

Interface options beyond Ethernet

The DCE supports the most common communication interfaces (Ethernet and EtherCat).

SL1042A-030 Additional EtherCat interface

Control cabinet is equipped with an extra EtherCat interface.

Project Management, Consulting and Installation Services

Service features depend on the facilities, customer expertise, and overall scope of the project. For that reason, it is not possible to give exact service efforts without knowing the customer's requirements and goals. Keysight offers the following services to secure a successful project execution and reduce ramp-up time for our customers.

PS-XPM-100-SL Project management services

Keysight recommends Project management services for each test bench project. By ordering the Project management services, an experienced project manager is dedicated to your project and acts as a direct communication interface from Keysight to the customer's project management team.

The project manager takes over the responsibility:

- To develop and manage the project plan.
- To track project progress and milestones.
- Communication project status regularly and ensure any unscheduled project events or project deviations are communicated and promptly discussed with the customer project team.
- To provide complete and accurate project documentation to the customer.

PS-XINS-100-SL Project installation services

These services provide installation expertise to manage, deliver and coordinate local facilities installation for the test bench. Specific installation efforts depend on the customer's individual facility, the locally available power and cooling and the test bench being delivered.

PS-XENG-100-SL Project engineering services

Project engineering services provide specialized engineering services during project development and implementation. The customer's project team will have access to engineering expertise to aid in various tasks specific to their project including but not limited to – safety matrix and test bench guard, facilities and lab layout, special power requirements, etc.

PS-XCOM-100-SL Project commissioning services

Project commissioning services for the test solution provide an experienced test bench engineer to validate and complete the test bench setup in readiness for the customer's initial usage. It includes validating specific hardware and software configurations per the project requirements and any specific consulting agreed to beforehand, given the test bench's customer-specific usage.

PS-S40-03 Productivity assistance

Productivity assistance is offered to support, consult and train the customers operation personnel to reduce the ramp-up time for initial usage of a new test bench, on the other hand with regards to any unexpected system behavior during the test bench life cycle. Productivity assistance is executed remotely (phone or internet) or on site (on request). It includes:

- direct access to an experienced system specialist via phone/internet
- support for failure analysis and trouble shoot
- software and programming support and consulting

Note: Keysight recommends at least two days of Productivity assistance for each test bench project.

Extend the Capabilities of your Test Solution

Keysight's Scienlab Charging Discovery System Series (CDS) is a breakthrough solution for holistic test of all AC and DC charging interfaces of electric vehicles (EV) and electric vehicle supply equipment (EVSE).

You can get further information to the Scienlab Charging Test Solutions below.



From left to right: SL1040A CDS – EMC Series, SL1040A CDS – Portable Series and SL1047A CDS – High-Power Series

Meet the SL1040A Scienlab Charging Discovery System Series

The Scienlab Charging Discovery System Series from Keysight enables you to test charging interfaces of electric vehicles (EVs) and EV supply equipment (EVSE). Thanks to its modular and innovative design, you can configure the CDS to customers' specific needs and replace multiple real EV/EVSE with one test solution to ensure an optimal price-performance ratio.

- Automated functional, conformance, interoperability and quality testing for R&D, end-of-line (EOL) and Electromagnetic Compatibility (EMC) applications.
- Time synchronous measurement and decoding of communication and power signals.
- Scalable and futureproof hardware design according to CharIN e.V. CCS Test System.
- CE, UL and KC-Mark conformance certified by CSA Group.
- Extensive Test Case Library for automated conformance testing of CCS, CHAdeMO and GB/T standard.

Find out more about the [SL1040A Scienlab CDS Series](#).

Meet the SL1047A Scienlab Charging Discovery System – High-Power Series

The Scienlab Charging Discovery System – High-Power Series (CDS HP Series) from Keysight enables you to test charging interfaces of electric vehicles (EVs) and EV supply equipment (EVSE) during high-power charging up to 1,500 V DC and ± 600 A DC. With the CDS can perform all necessary conformance and interoperability tests according to worldwide charging standards. Our new solution, which features the separate Scienlab Cooling Unit with interchangeable liquid-cooled charging adapters, also enables a high-power upgrade of the SL1040A Scienlab Charging Discovery System – Portable Series.

- Automated functional, conformance, interoperability and quality testing for R&D and EOL applications.
- Time synchronous measurement and decoding of communication and power signals.
- Scalable and future-proof hardware design according to CharIN e. V. CCS Test System.
- CE, UL, and KC-mark conformance.
- Extensive Test Case Library for automated conformance testing of CCS, CHAdeMO, and GB/T standard.

Find out more about the [SL1047A Scienlab CDS HP Series](#).

Learn more at: www.keysight.com

For more information on Keysight Technologies' products, applications, or services, please contact your local Keysight office. The complete list is available at: www.keysight.com/find/contactus

