

---

# Keysight X-Series Signal Analyzer

N9032B

IQ Streaming

Option S01 and S02

# Notices

© Copyright 2023-2024 Keysight Technologies, Inc.

The information contained in this document is subject to change without notice.

Keysight Technologies makes no warranty of any kind with regard to this material, including but not limited to, the implied warranties of merchantability and fitness for a particular purpose.

Keysight Technologies shall not be liable for errors contained herein or for incidental or consequential damages in connection with the furnishing, performance, or use of this material.

## **Manual Part Number**

N9032-90011

## **Edition**

Edition 2, December 2024

Supersedes: May 2023

Printed in Malaysia

Published by:

Keysight Technologies, Inc.  
1400 Fountaingrove Parkway  
Santa Rosa, CA 95403

## Option S01 and S02 – IQ Streaming

Products Affected:	PXA N9032B (with Option 508/513/526, serial prefix <MY/SG6319)
To Be Performed By:	<input checked="" type="checkbox"/> Keysight Service Center <input type="checkbox"/> Advanced User <input type="checkbox"/> User
Estimated Installation Time:	2.0 Hours
Estimated Adjustment Time:	1.0 Hours
Estimated Verification Time:	1.0 Hours

This document provides detailed instructions for the installation of the IQ Streaming upgrades for the N9032B PXA Signal Analyzer with Option 508/513/526, serial prefix <MY/SG6319.

Option S01 and S02 are the designations used to order an upgrade for options ST1 and ST2 for earlier instruments that require an extended amount of hardware. While the owner of the instrument may have ordered option S01 or S02, this upgrade will install option ST1 or ST2.

Please be sure to read this entire document before attempting to perform this upgrade. Then, be sure to perform the steps in this procedure in the order that they are listed so that the installation will complete properly, and the instrument will function as desired when completed.

### Compatibility

This instrument option requires that the instrument has firmware version A.34.00 or newer. If the instrument being upgraded does not currently meet this requirement the following procedure includes a step to update it.

### Instrument Calibration

The validity of any existing calibration that the instrument being upgraded may have will not be affected by the installation of this upgrade.

## What you will find in this document

ESD Information .....	page 5
Upgrade Contents .....	page 7
Tools Required .....	page 8
Initial Instrument Functionality Check .....	page 8
Instrument Software Revision Check .....	page 8
Upgrade Instructions .....	page 9
Hardware Disassembly .....	page 9
ODI Cable Installation .....	page 15
Hardware Assembly .....	page 22
Instrument Button Up .....	page 26
Rear Panel Labels .....	page 29
Instrument Software Installation .....	page 30
License Key Retrieval and Installation .....	page 30
Adjustments and Performance Verification .....	page 31
Manual Procedures Required .....	page 31
Automated Utilities Required .....	page 31
Automated Adjustments Required .....	page 31
Automated Performance Testing Required .....	page 31
ODI Loopback Test .....	page 32

## ESD Information

### Protection from Electrostatic Discharge

Electrostatic discharge (ESD) can damage or destroy electronic components. All work on electronic assemblies should be performed at a static-safe workstation. **Figure 1** shows an example of a static-safe workstation using two types of ESD protection:

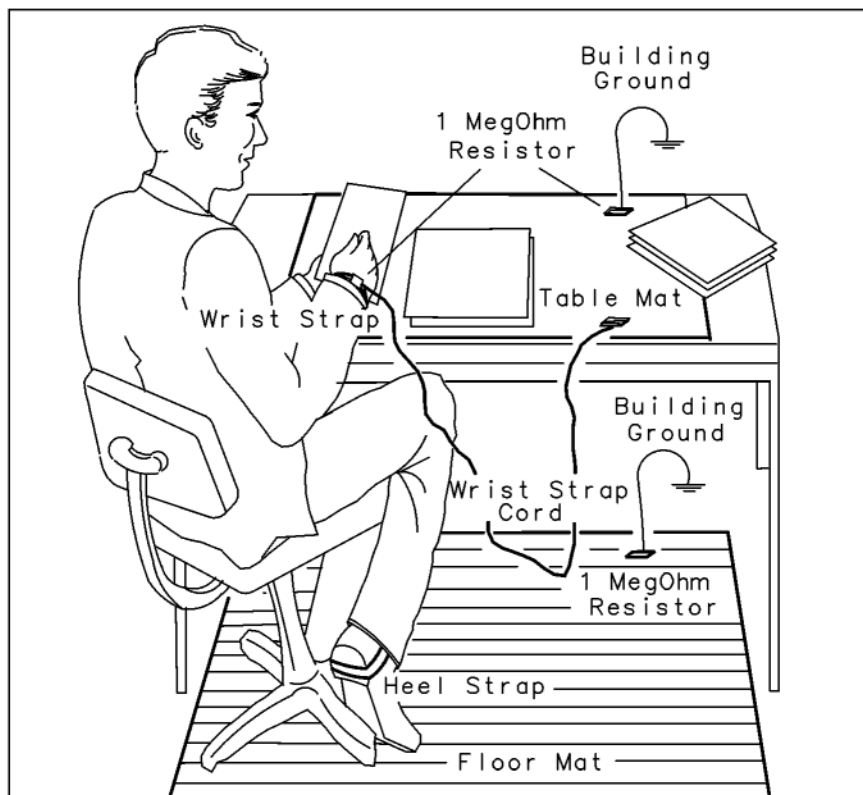
- Conductive table-mat and wrist-strap combination.
- Conductive floor-mat and heel-strap combination.

Both types, when used together, provide a significant level of ESD protection. Of the two, only the table-mat and wrist-strap combination provides adequate ESD protection when used alone. To ensure user safety, the static-safe accessories must provide at least 1 megohm of isolation from ground.

#### **WARNING**

These techniques for a static-safe workstation should not be used when working on circuitry with a voltage potential greater than 500 volts.

Figure 1 Example of a Static-Safe Workstation



## Handling of Electronic Components and ESD

The possibility of unseen damage caused by ESD is present whenever components are transported, stored, or used. The risk of ESD damage can be greatly reduced by paying close attention to how all components are handled.

- Perform work on all components at a static-safe workstation.
- Keep static-generating materials at least one meter away from all components.
- Store or transport components in static-shielding containers.

### CAUTION

Always handle printed circuit board assemblies by the edges. This will reduce the possibility of ESD damage to components and prevent contamination of exposed plating.

---

## Test Equipment Usage and ESD

- Before connecting any coaxial cable to an analyzer connector, momentarily short the center and outer conductors of the cable together.
- Personnel should be grounded with a 1 megohm resistor-isolated wrist-strap before touching the center pin of any connector and before removing any assembly from the analyzer.
- Be sure that all analyzers are properly earth-grounded to prevent build-up of static charge.

## For Additional Information about ESD

For more information about preventing ESD damage, contact the Electrical Over Stress/Electrostatic Discharge (EOS/ESD) Association, Inc. The ESD standards developed by this agency are sanctioned by the American National Standards Institute (ANSI).

## Upgrade Contents

Table 1 Upgrade Contents

Part Number	Description	Quantity
0515-0372	Screw-Machine w/Crest-Cup-Con-Washer Pan-HD Torx-T10 M3X0.5 8mm-LG	2
0515-0666	Screw-Machine w/Crest-Cup-Washer Pan-HD Torx-T10 M3X0.5 18mm-LG	1
0515-1946	Screw-Machine w/Patch Lock 90-DEG-flat-HD Torx-T10 M3X0.5 6mm-LG	18
0515-2332	Screw-Machine w/Patch-Lock Pan-HD Torx-T10 M3X0.5 6mm-LG	4
0515-5208	Screw-Machine w/Patch-Lock Flat-HD Torx-T6 M2X0.4 4mm-LG	1
1005-1388	Fiber Optic Adapter MPO-Shutter Female-Female flange-mount	1
1400-0082	Screw Mount Cable Clamp	4
1400-0249	Nylon Cable Tie	4
1400-1254	Adhesive Cable Clip	2
9030-0000	License Entitlement Certificate	1
M8121-60004	Connector-Fiber Optic Multimode MPO-Loopback	1
M8121-61614	Cable AY, Patch cord, ODI, F-F, 24 fiber, Type C, 3 M lg	1
M9484-80052	Label, FDA Laser	1
N9032-00015	Rear Panel	1
N9032-61000	Cable Assembly, Optical FireFly TX/RX	1
N9032-65058	A21 Wideband Digital IF	1
N9041-20181	Insertion Tool, FireFly	1
N9048-80014	A21 Wideband Digital IF Connector Label	1

## Option S01 and S02 – IQ Streaming

### Tools Required

- Torx Driver T-10
- Torx Driver T-20
- Multi-Bit Torque Driver
- 5/8" Nut Driver
- 5/16" Wrench

### Initial Instrument Functionality Check

Power on the instrument and allow it to complete its boot up process. Verify that there are no instrument messages that would indicate that there is an issue with either the instrument hardware or software. If there are any issues, investigate and fix the problem before continuing with this upgrade.

### Instrument Software Revision Check

While the instrument is still powered on check to see what version of the instrument software is installed. To do so press **System, Show System** and look on the System Information screen for the **Instrument S/W Revision**. Record the software revision below.

**Instrument S/W Revision Installed:** \_\_\_\_\_

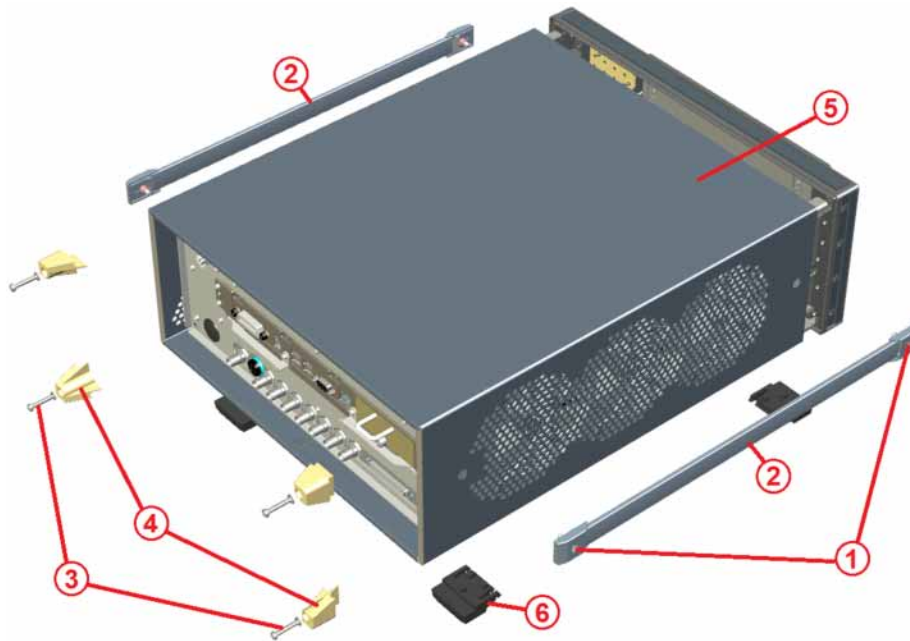
## Upgrade Instructions

### Hardware Disassembly

#### Dress Cover Removal

1. Turn the instrument off and disconnect the power cord.
2. Referring to **Figure 2**, remove the two screws (1) that attach the strap handle (2) from both sides and remove the strap handles.

**Figure 2** Dress Cover Removal

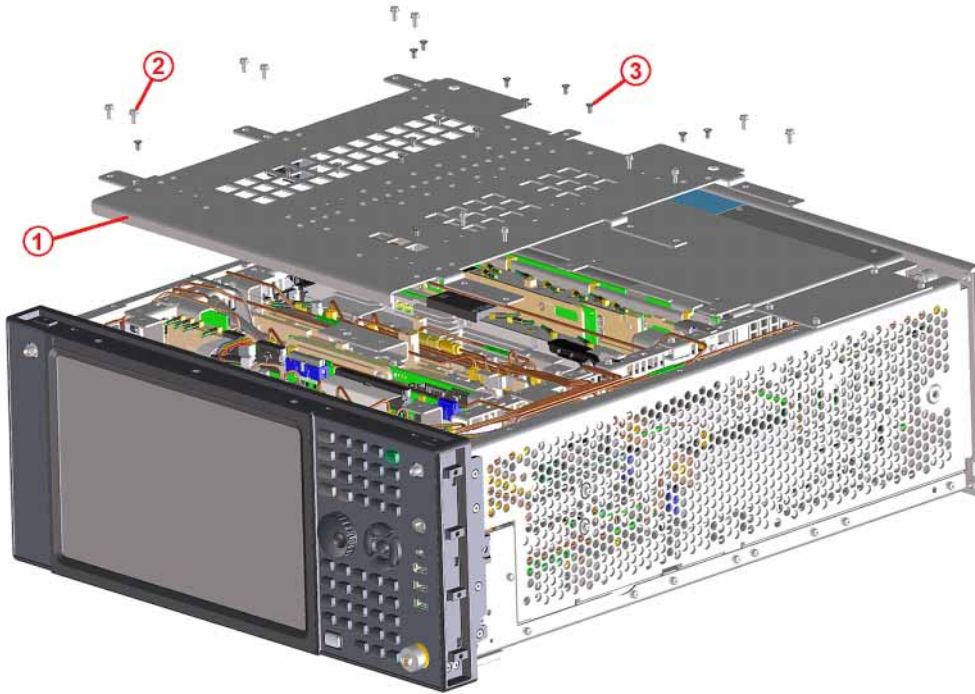


3. Remove the four rear feet (4) by removing the four screws (3) and washers that attach them.
4. Remove the four bottom feet (6) by first removing the locking keys and then lifting the tabs and sliding the foot toward the tabs.
5. Carefully slide the dress cover (5) off the instrument.

### Top Brace Removal

6. Referring to **Figure 3**, remove the sixteen flathead screws (2) and twelve panhead screws (3) attaching the top brace (1) to the instrument and set it aside. The sixteen flathead screws can be discarded, and they will be replaced with new ones.

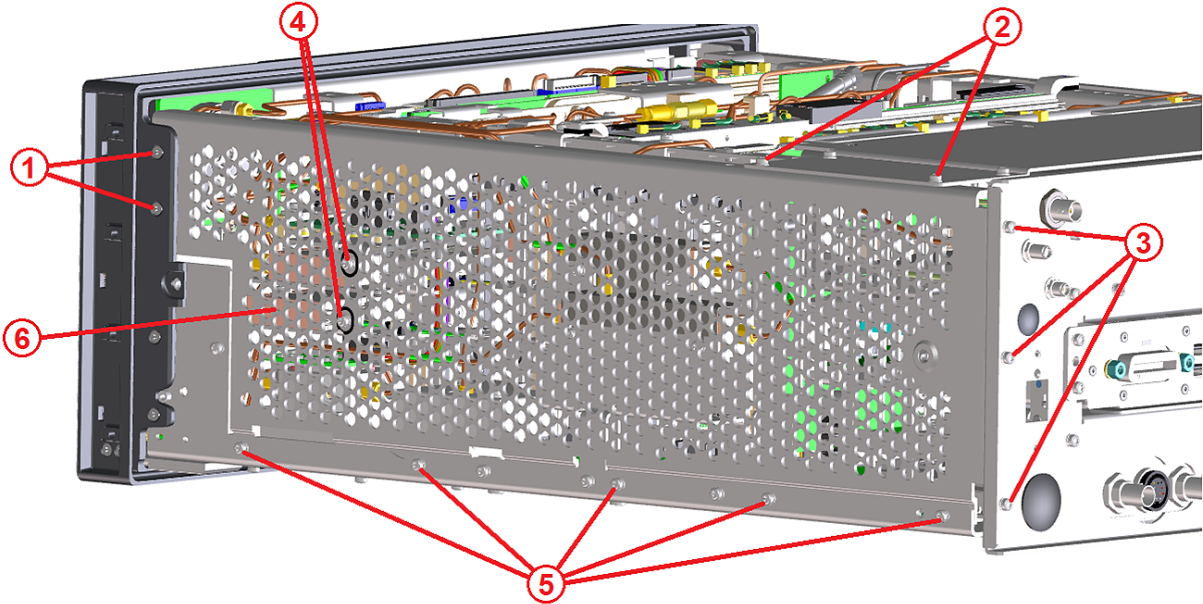
**Figure 3** Remove Top Brace



Side Bracket Removal

- 7. Referring to **Figure 4**, remove the two flathead screws (1), the two panhead screws (2), the three panhead screws (3), the two panhead screws (4), and the five panhead screws (5) that attach the side bracket (6) to the instruments. Then remove the side bracket.

**Figure 4** Side Bracket Removal



## Rear Panel Replacement

8. Referring to **Figure 5**, remove the three nut and lock washers (1) securing the three SMA connectors to the rear panel.
9. Remove the nut and lock washer (2) securing the BNC connector to the rear panel.

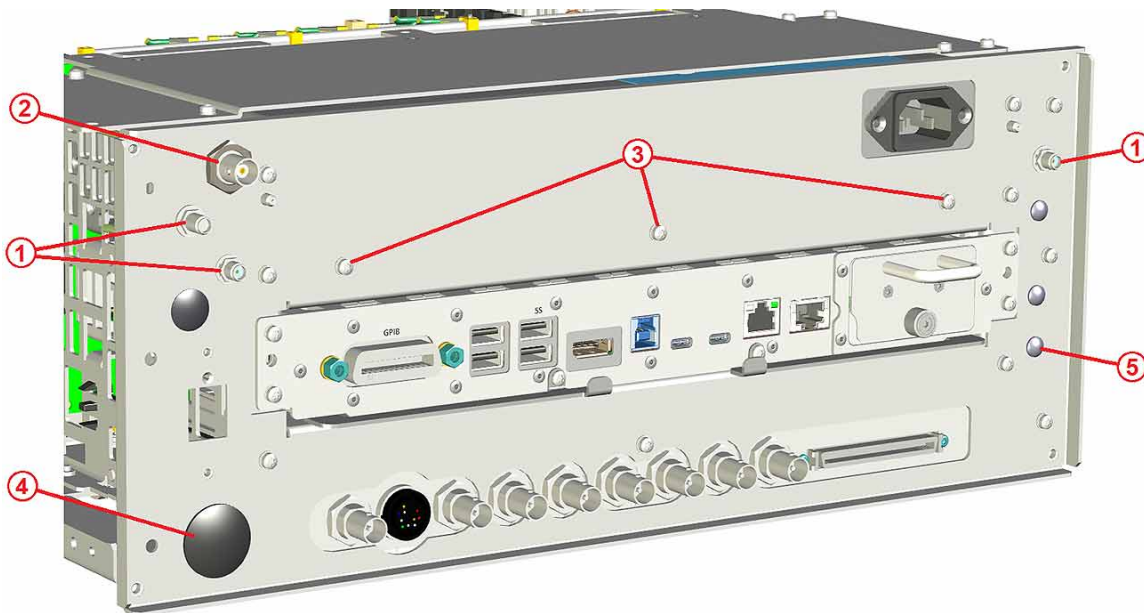
**Figure 5** Remove Rear Panel



10. Remove the thirteen panhead screws (3) attaching the rear panel (5) to the instrument and remove the rear panel.
11. Remove all the hole plugs (4) from the rear panel and discard the panel.
12. Install the hole plugs into the new rear panel provided in this kit.

13. Referring to **Figure 6**, place the new rear panel on the instrument while guiding the SMA and BNC cables into their corresponding holes in the rear panel.

**Figure 6** Install New Rear Panel



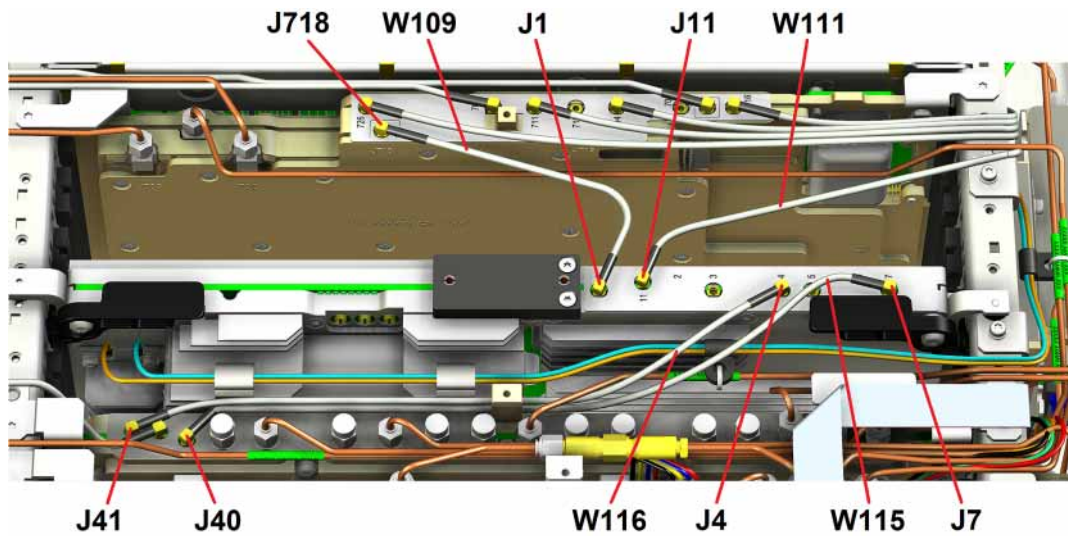
- 14. Secure the three SMA connectors to the new rear panel with their lock washers and nuts (1). Torque the nuts to 10 in-lbs.
- 15. Secure the BNC connectors to the new rear panel with its lock washer and nut (2). Torque the nut to 21 in-lbs.
- 16. Secure the new rear panel to the instrument using the thirteen panhead screws (3). Torque the screws to 9 in-lbs.

Option S01 and S02 – IQ Streaming

### A21 Wideband Digital IF Removal

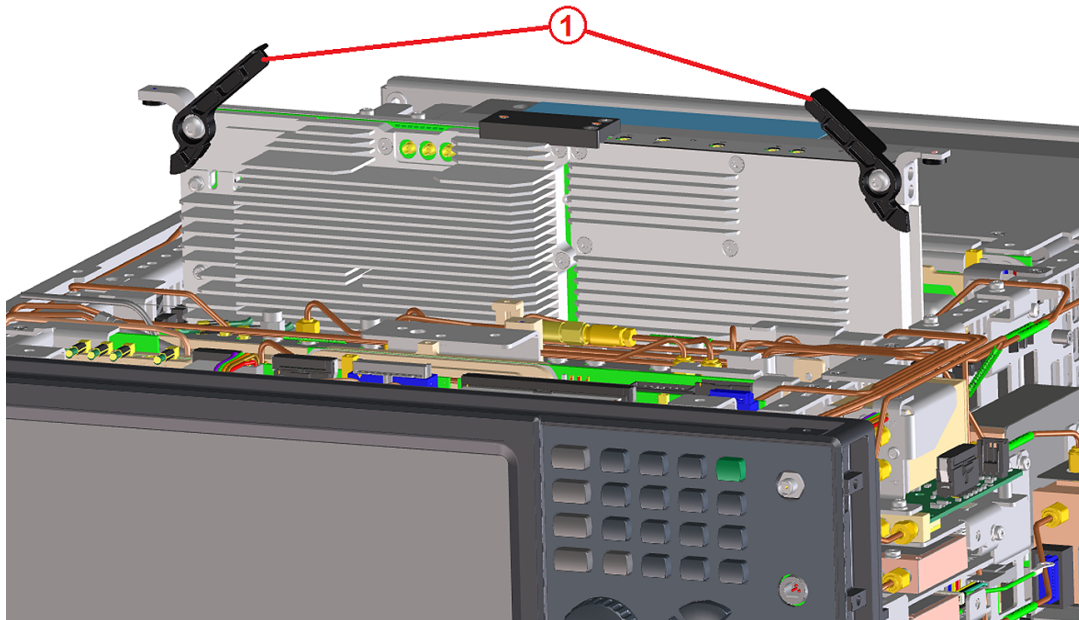
17. Referring to **Figure 7**, remove all the flexible RF cables highlighted from the A21 Wideband Digital IF assembly.

**Figure 7** A21 Wideband Digital IF Connections Removal



18. Referring to **Figure 8**, use the two board extractors (1) to carefully remove the A21 Wideband Digital IF from the instrument.

**Figure 8** A21 Wideband Digital IF Extraction



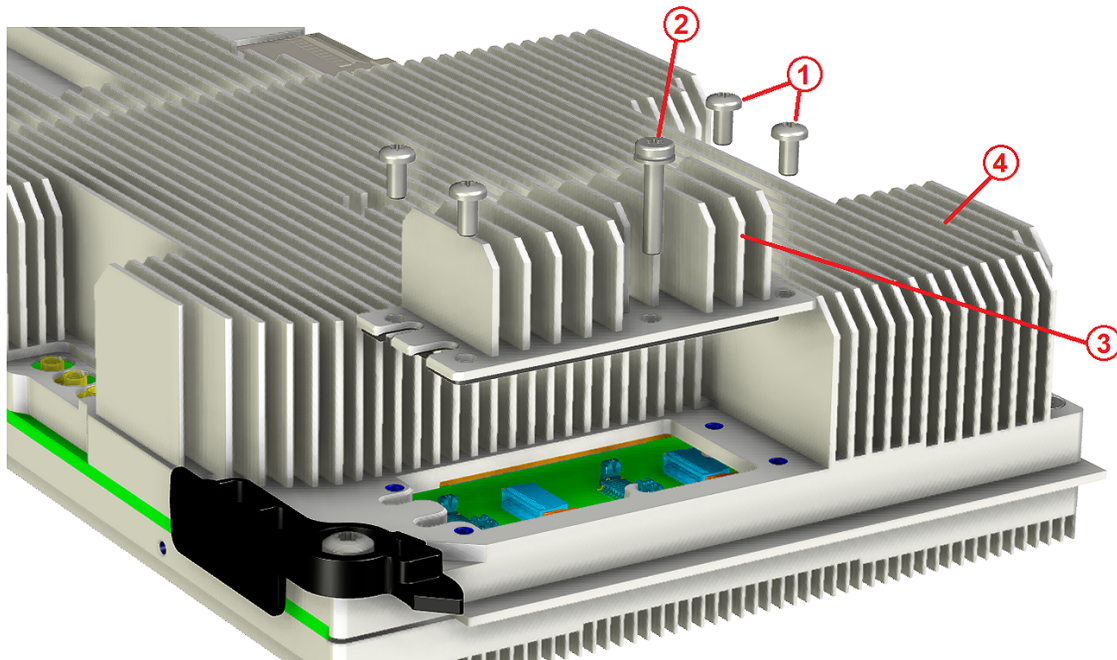
19. Discard the A21 Wideband Digital IF and replace it with the one provided in this kit.

## ODI Cable Installation

### ODI Heatsink Removal

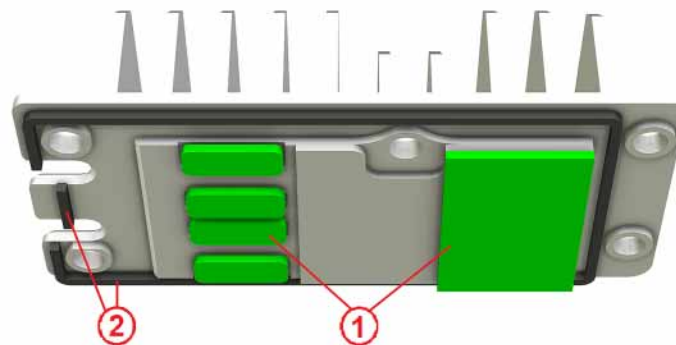
1. Referring to **Figure 9**, remove the four short panhead screws (1) and the one long panhead screw (2) attaching the ODI heatsink (3) to the A21 Wideband Digital IF (4).

**Figure 9** ODI Heatsink Removal



2. Remove the ODI heatsink (3) from the A21 Wideband Digital IF (4), making sure that all the thermal pads (1) and gasketing (2) come with it, as seen in **Figure 10**. Discard the heatsink, the gasketing, and the thermal pads.

**Figure 10** ODI Heatsink Thermal Pads and Gasketing

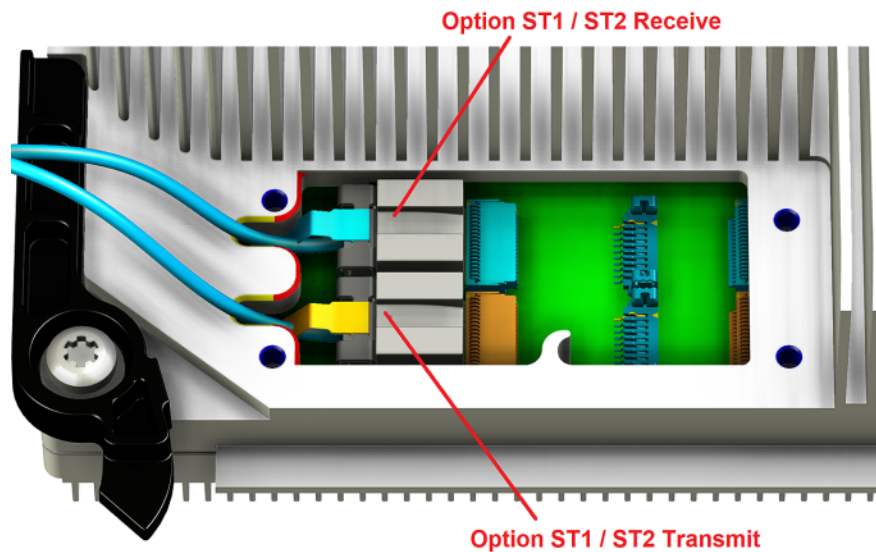


## Option S01 and S02 – IQ Streaming

### ODI Cable Installation

The ODI cable provided in this kit has two connectors that need to be installed on the A21 Wideband Digital IF assembly. One is blue and the other is orange. The blue connector is the receiver end, and the orange is the transmitter, so they need to be installed in the correct location on the A21 assembly, as seen in **Figure 11**.

**Figure 11** ODI Cable Connector Locations



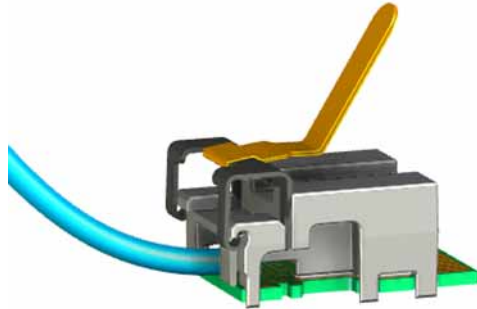
There is a tool included in this kit that needs to be used to install these connectors, as seen in **Figure 12**. The following procedure will describe and illustrate how this tool is used.

**Figure 12** ODI Connector Tool



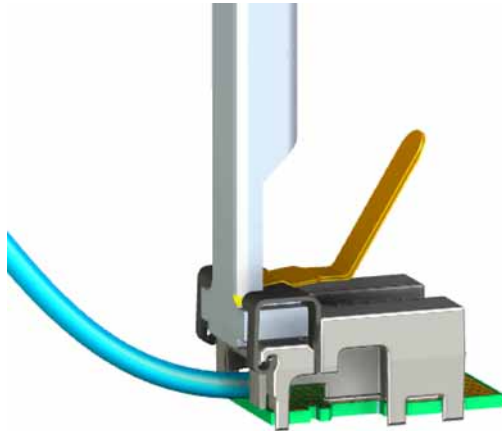
3. Use the pull tab on the orange ODI cable connector to lift the locking tab of the connector up, as seen in **Figure 13**.

**Figure 13** ODI Connector Unlocked



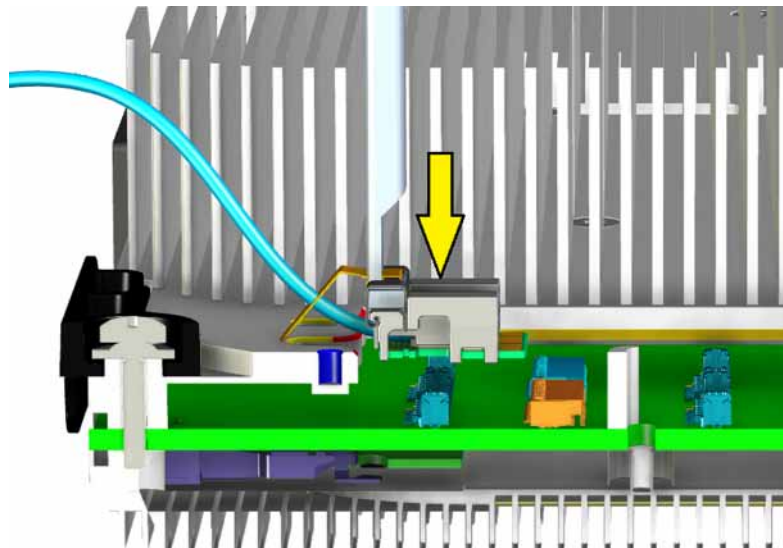
4. Insert the connector tool into the connector lock, as seen in **Figure 14**.

**Figure 14** ODI Tool Inserted into Connector Lock

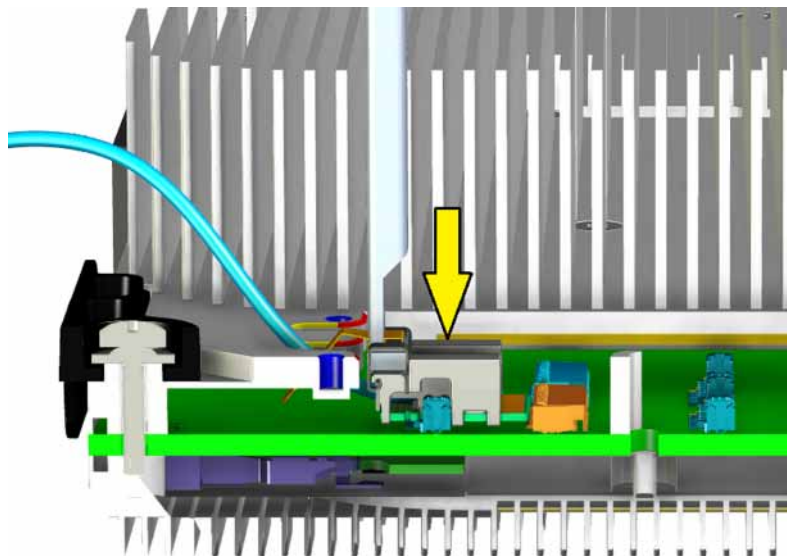


5. Use the connector tool to lower the cable connector over the orange connector on the A21 Wideband Digital IF, as seen in [Figure 15](#) and [Figure 16](#).

**Figure 15** Lower Cable Connector into Place

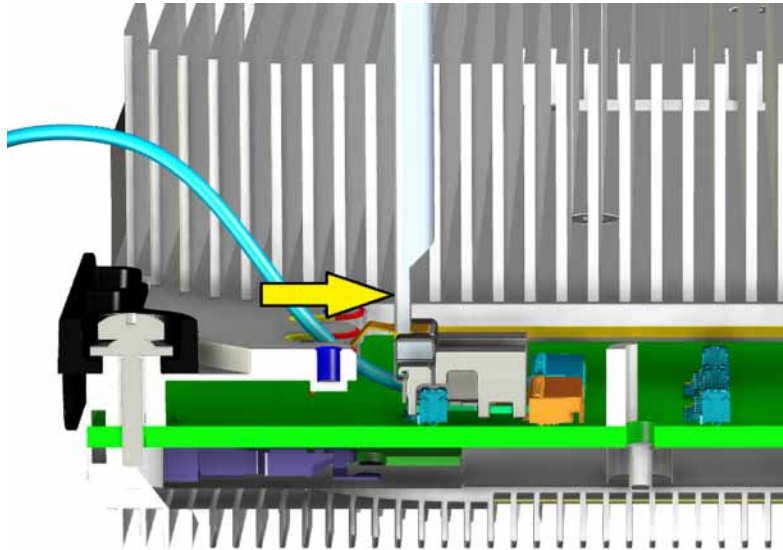


**Figure 16** Cable Connector Lowered onto Board



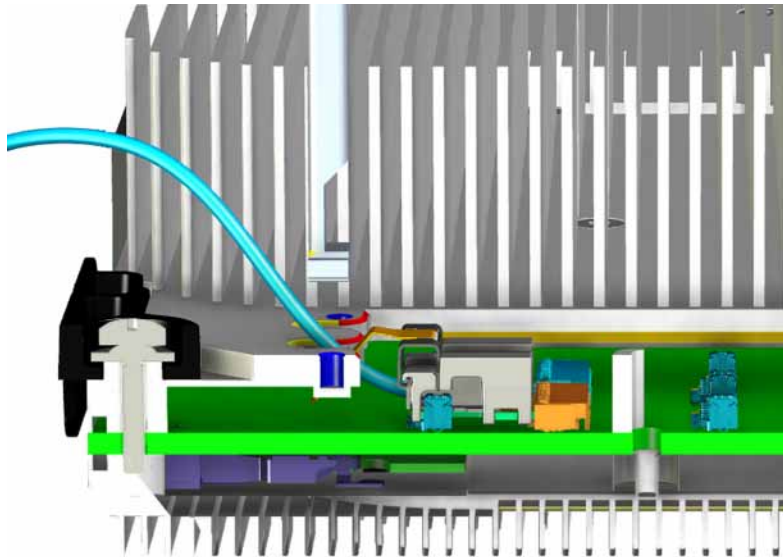
6. Use the tool to slide the connector forward to engage the connector, as seen in [Figure 17](#).

**Figure 17** Cable Connector Slide into Place



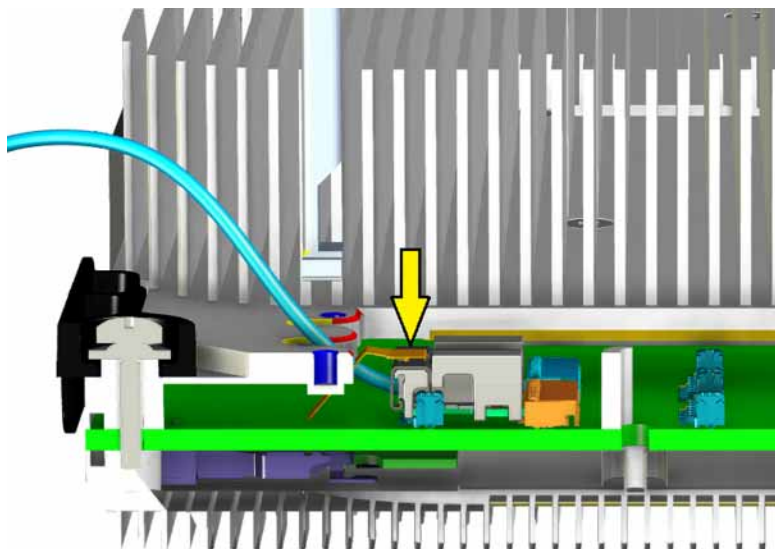
7. Remove the connector tool from the ODI cable connector, as seen in [Figure 18](#).

**Figure 18** ODI Tool Removed



8. Press the cable connector lock down to lock it into place, as seen in [Figure 19](#).

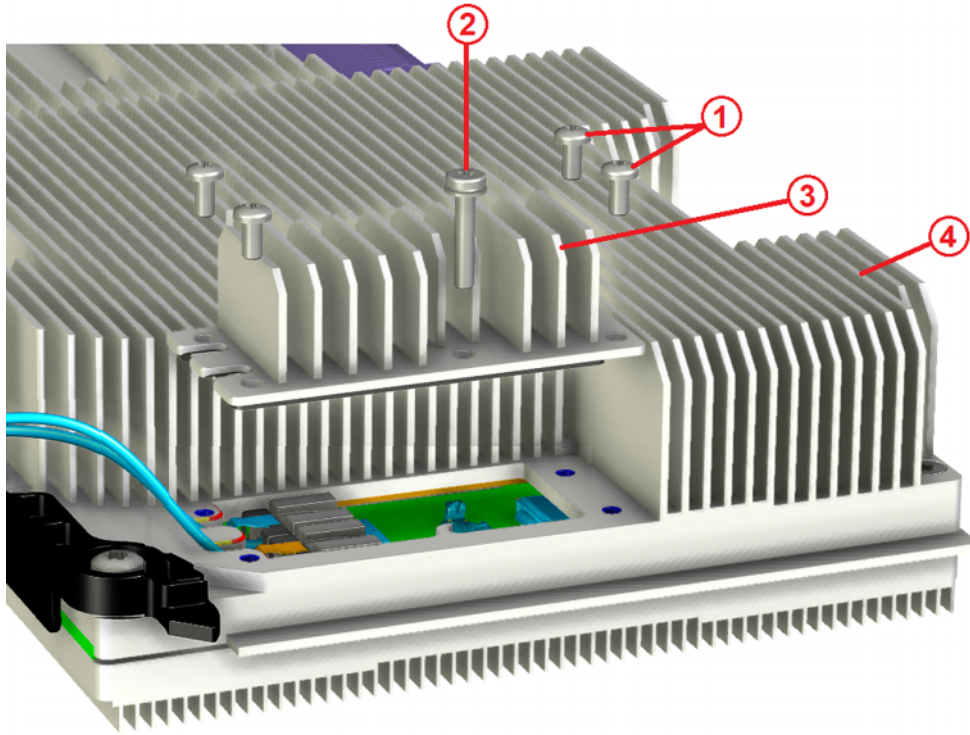
**Figure 19** Cable Connector Locked into Place



9. Use the ODI connector tool to install the blue cable connector into the connector on the A21 Wideband Digital IF next to the orange cable that was just installed, as seen in [Figure 11](#).
10. Properly route all the ODI cables so that they do not get pinched when the new heatsink is put into place, as seen in [Figure 11](#).

11. Referring to **Figure 20**, install the new ODI heatsink (3) with four short new flathead screws (1) and the one original long flathead screw (2) onto the A21 Wideband Digital IF assembly (4). Torque all the screws to 9 in-lbs.

**Figure 20** Install New ODI Heatsink



**NOTE**

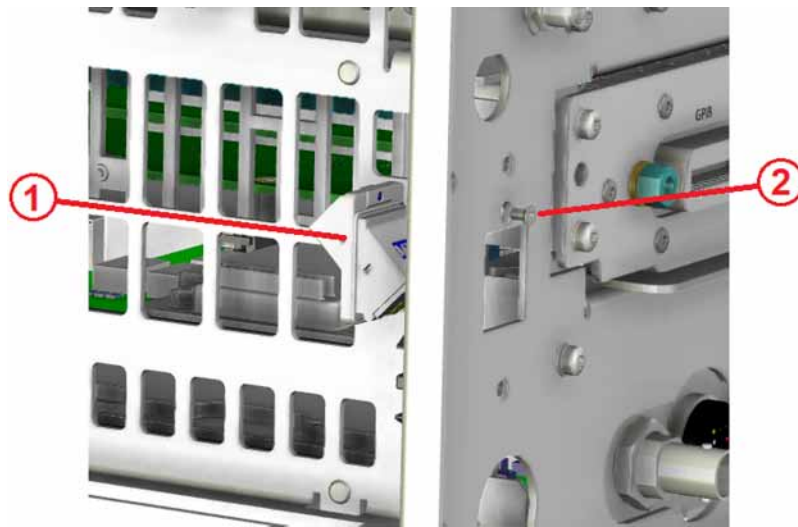
Be sure that all the thermal pads and gasketing are properly in place on the underside of the heatsink, as seen in **Figure 10**, before placing the new heat sink in position.

## Hardware Assembly

### Install Rear Panel ODI Connector

1. Referring to **Figure 21**, attach the rear panel ODI connector (1) to the rear frame using the flathead screw provided (2). Torque the screw to 6 in-lbs.

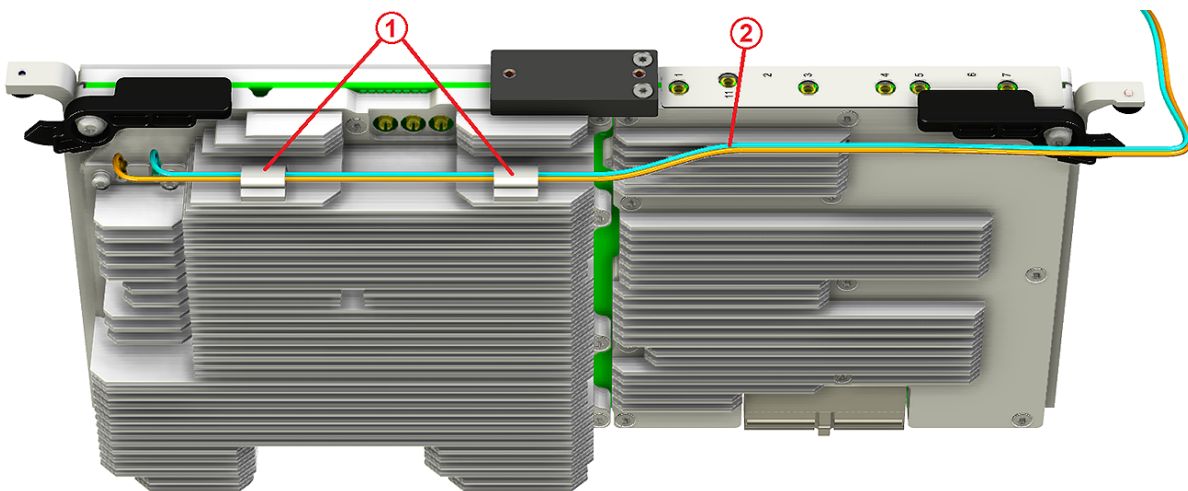
**Figure 21** Install Rear Panel ODI Connector



### Reinstall A21 Wideband Digital IF

2. Install the two adhesive cable clips (1) to the A21 Wideband Digital IF heatsink (1), as seen in **Figure 22**.

**Figure 22** Adhesive Cable Clips Installation



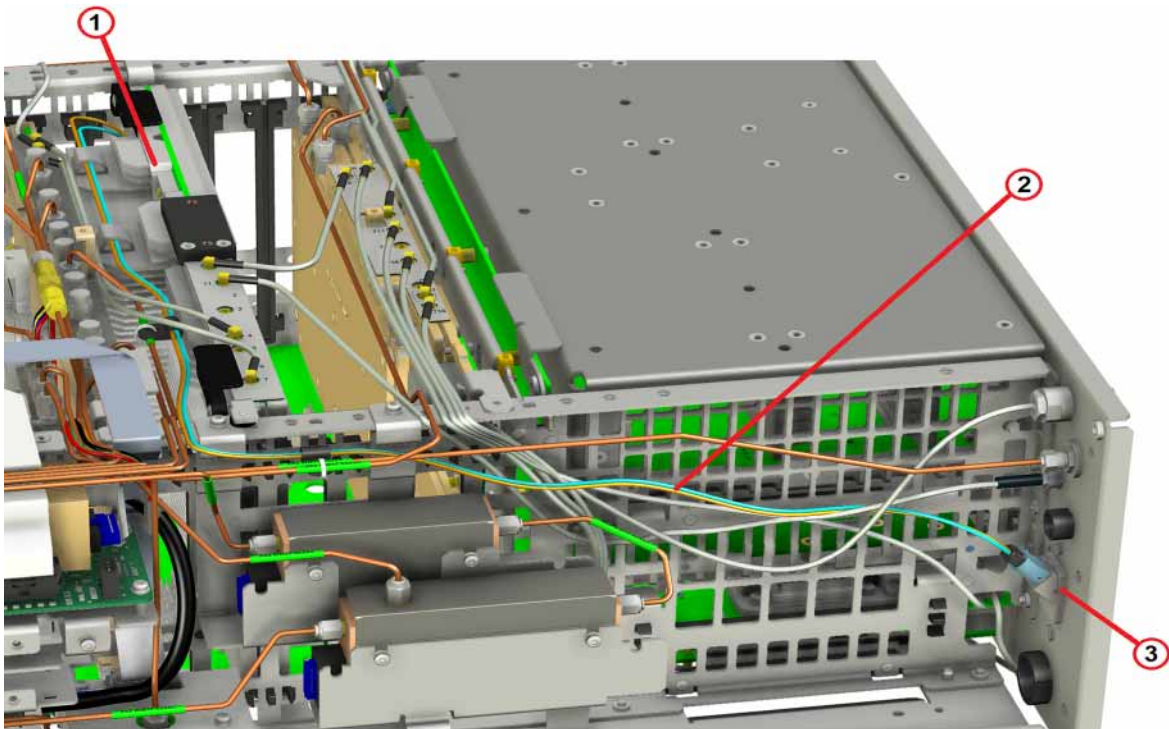
3. Insert the ODI cable (2) into the two adhesive cable clips (1), as seen in [Figure 22](#).

**CAUTION**

Great care needs to be taken when installing, removing, and handling any of the Optical Data Interface cables as they can be easily damaged if they are bent too tight or pinched.

4. Referring to [Figure 23](#), reinstall the A21 Wideband Digital IF assembly (1) back into Slot 5 of the A8 Motherboard, while carefully routing the ODI cable (2) as shown.
5. Insert the end of the ODI cable into the rear panel ODI connector (3) that was just installed.

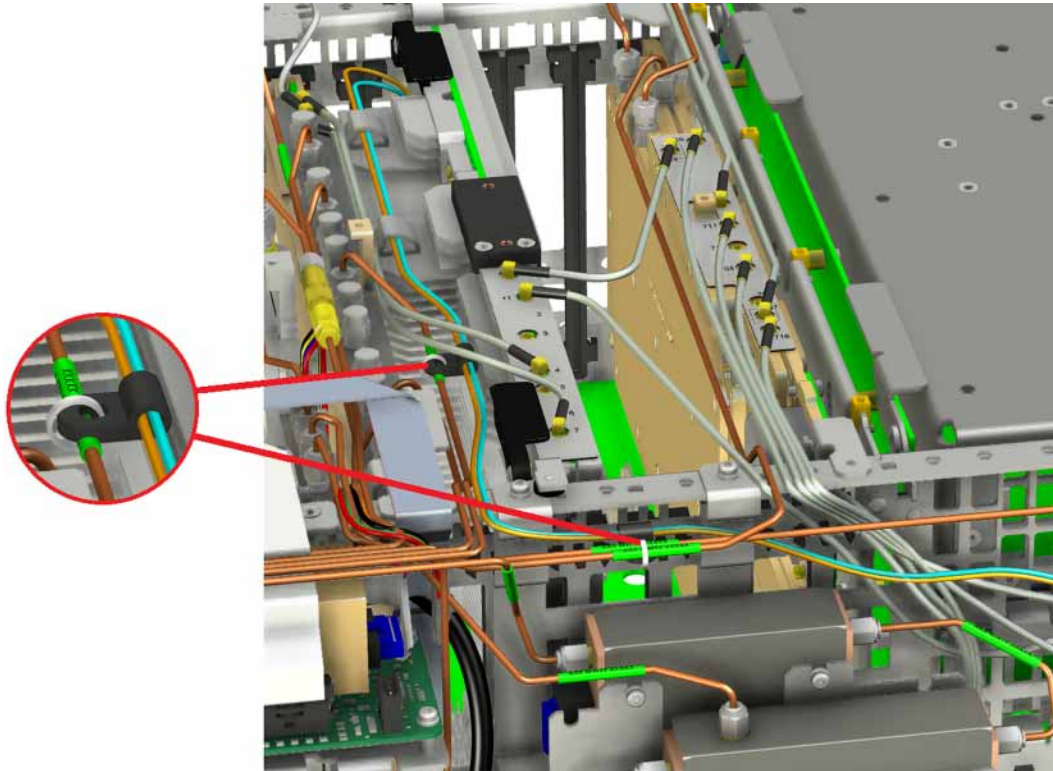
**Figure 23** A21 Wideband Digital IF and ODI Cable Installation



### Secure ODI Cable

6. Referring to **Figure 24**, secure the ODI cable to the semi-rigid cables using two screw mount cable clamps and two nylon cable ties in the areas shown.

**Figure 24** Secure ODI Cable to Semi-Rigid Cables



7. Referring to **Figure 25**, secure the ODI cable to the instrument chassis with two nylon cable ties in the locations shown.

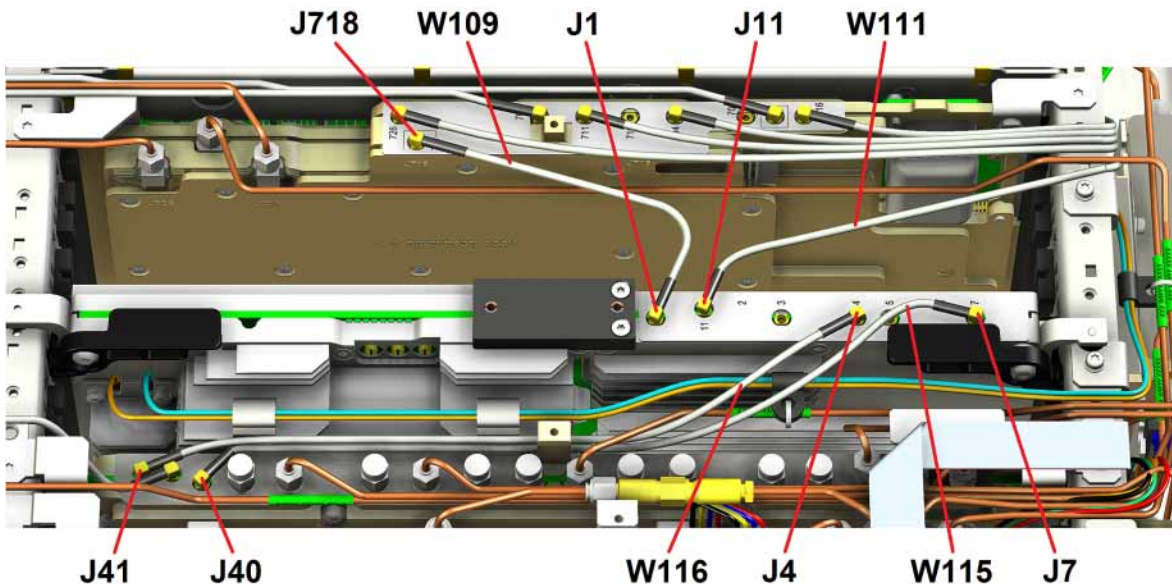
**Figure 25** Secure ODI Cable to Chassis



Reinstall A21 Coax Cables

- Referring to **Figure 26**, reinstall the four coax cables to the A21 Wideband Digital IF, as listed in **Table 2**.

**Figure 26** A21 Wideband Digital IF Connections



**Table 2** A21 Wideband Digital IF Connections

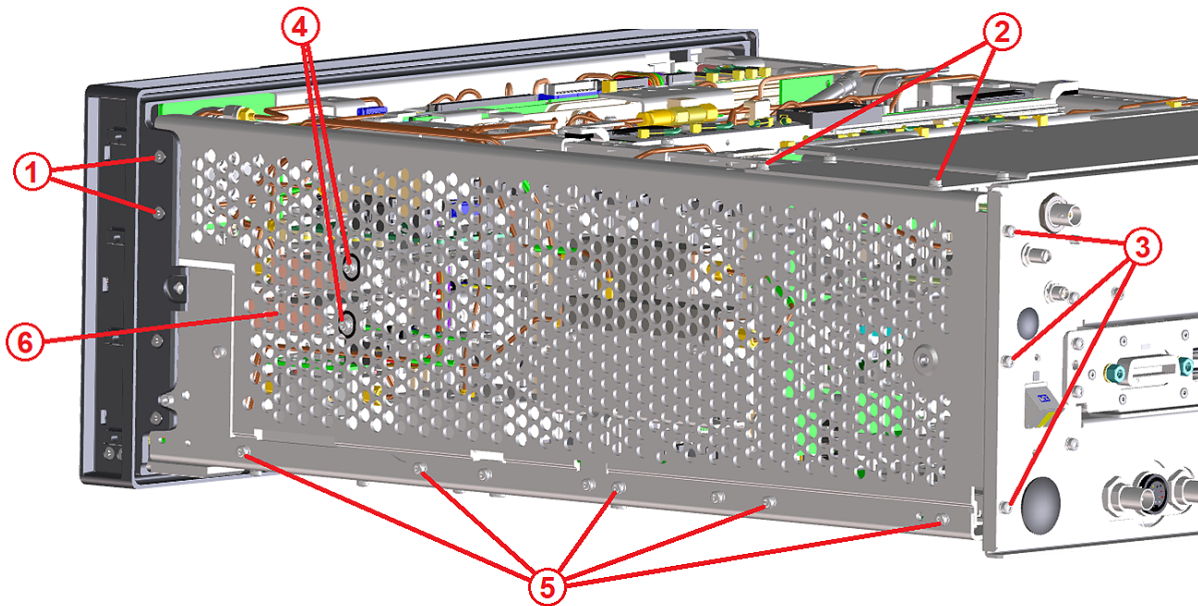
A21 Port	To/From	Cable
J1	From A16 Reference J718	W109
J4	From A23 IF Mux J41	W116
J7	From A23 IF Mux J40	W115
J11	From Rear Panel Trigger 3 In	W111

## Instrument Button Up

### Side Bracket Installation

1. Referring to **Figure 27**, reinstall the side bracket (6) and secure it to the instrument using the two flathead screws (1), the two panhead screws (2), the three panhead screws (3), the two panhead screws (4), and the five panhead screws (5). Torque all screws to 9 in-lbs.

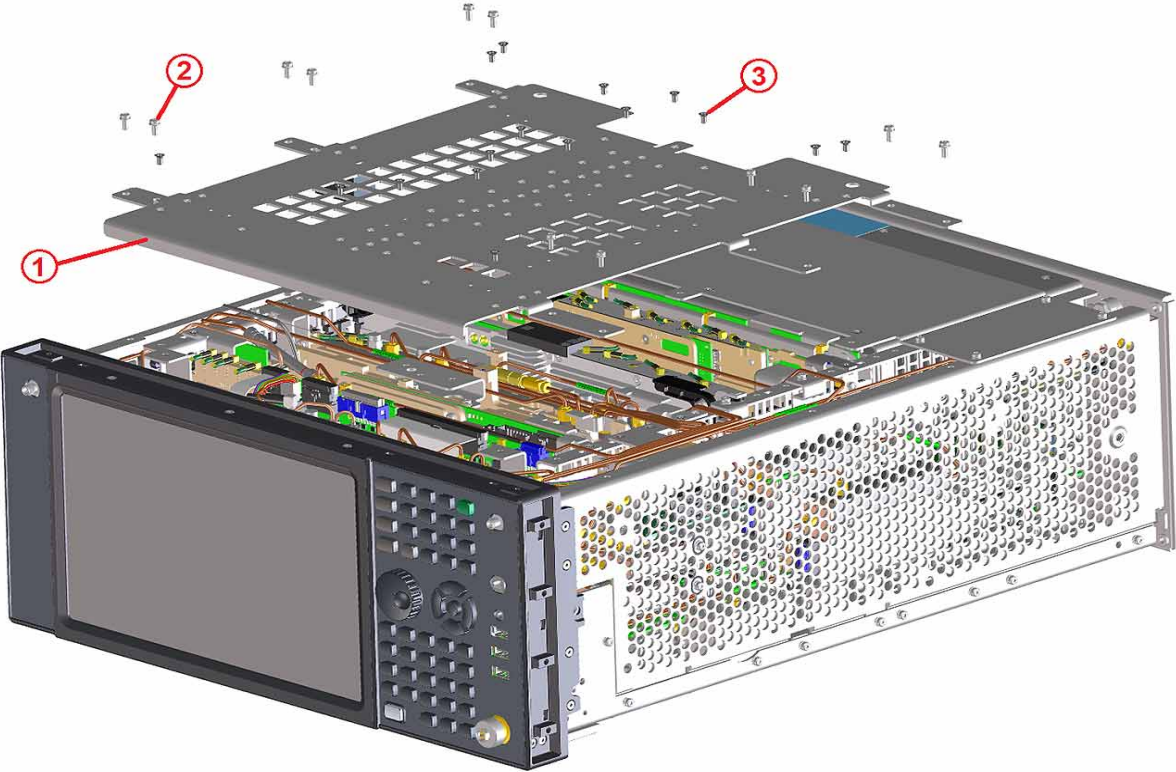
**Figure 27** Side Bracket Installation



Top Brace Installation

- 2. Referring to **Figure 28**, replace the top brace (1) and secure it with the sixteen new flathead screws (3) and the twelve panhead screws (2). Torque all screws to 9 in-lbs.

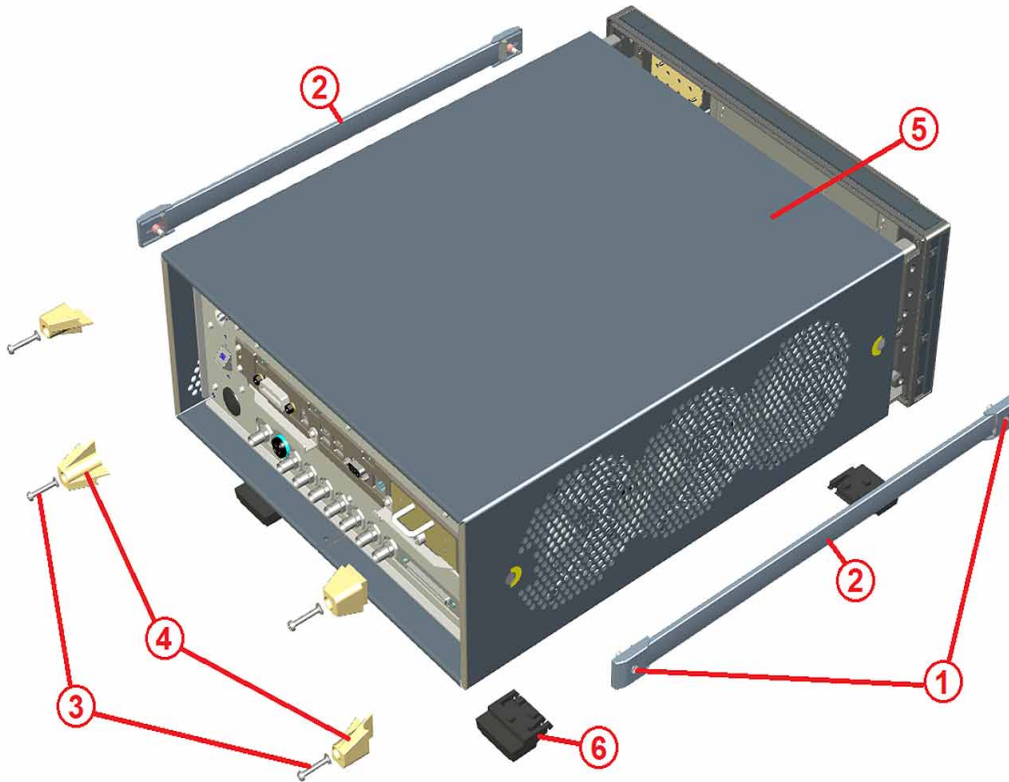
**Figure 28** Top Brace Installation



### Dress Cover Installation

3. Referring to **Figure 29**, carefully slide the outer cover (5) onto the instrument.

**Figure 29** Dress Cover Installation



4. Attach the four rear feet (4) using the four panhead screws and washers (3). Torque the screws to 21 in-lbs.
5. Install the four bottom feet (6) along with the locking keys.
6. Install the strap handles (2) to both side of the instrument using the two screws (1) at either end of the handles. Torque the screws to 21 in-lbs.

### Rear Panel Labels

**NOTE**

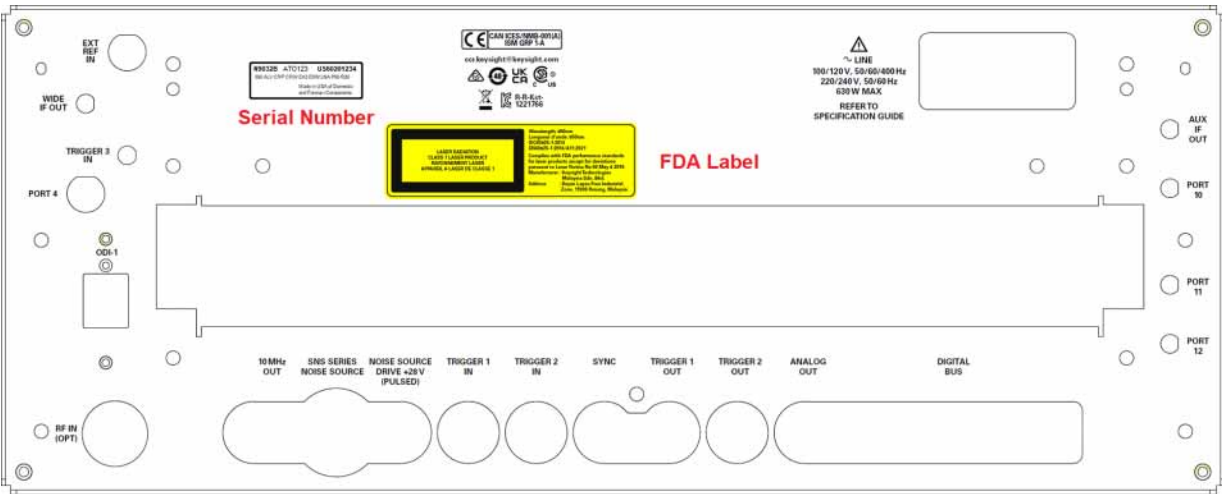
It is very important that all instructions in this section be closely followed, as legal and safety matters are involved.

### FDA Laser Certification Label

Once upgraded, all instruments need to have one of the FDA Laser Certification labels attached to the rear panel.

The FDA laser certification label needs to be attached in the area outlined in **Figure 30**.

**Figure 30 Rear Panel Label Locations**



### Serial Number Label

Since the rear panel was changed during this upgrade, the serial number label will need to be carefully transferred from the original rear panel to the new one.

The serial number label needs to be attached in the area outlined in **Figure 30**.

## Instrument Software Installation

The instrument software is required to be version A.34.00 or newer for this option to be recognized. If the instrument being upgraded does not already have a version that meets this requirement, the instrument software will need to be installed at this time.

1. Download the latest instrument software version and instructions from:

[https://www.keysight.com/find/n9032b\\_software](https://www.keysight.com/find/n9032b_software)

2. When the instrument software update has completed the instrument will be ready to proceed with the next step in this procedure.

## License Key Retrieval and Installation

1. Follow the instructions on the enclosed License Entitlement Certificate to redeem the new option license key for the instrument being upgraded.
2. Once the new license keys have been redeemed follow the installation instructions that come with the license file to install it into the instrument.
3. Once the license has been installed cycle the instrument power.
4. Verify that the license has been installed by pressing **System, Show System** and verify that the option is present in the listed options.

## Adjustments and Performance Verification

### **Manual Procedures Required**

ODI Loopback Test

### **Automated Utilities Required**

None

### **Automated Adjustments Required**

All Frequency Response Adjustments

All IF Frequency Response Adjustments

### **Automated Performance Testing Required**

Noise Density

Residual Response

Displayed Average Noise Level

IF Frequency Response

IF Amplitude Accuracy

For assistance, contact your nearest Keysight Technologies Sales and Service Office.  
To find your local office access the following URL:

<https://www.keysight.com/find/assist>

## ODI Loopback Test

Use the following procedure to run the loopback test to verify that the newly installed streaming option hardware is working properly.

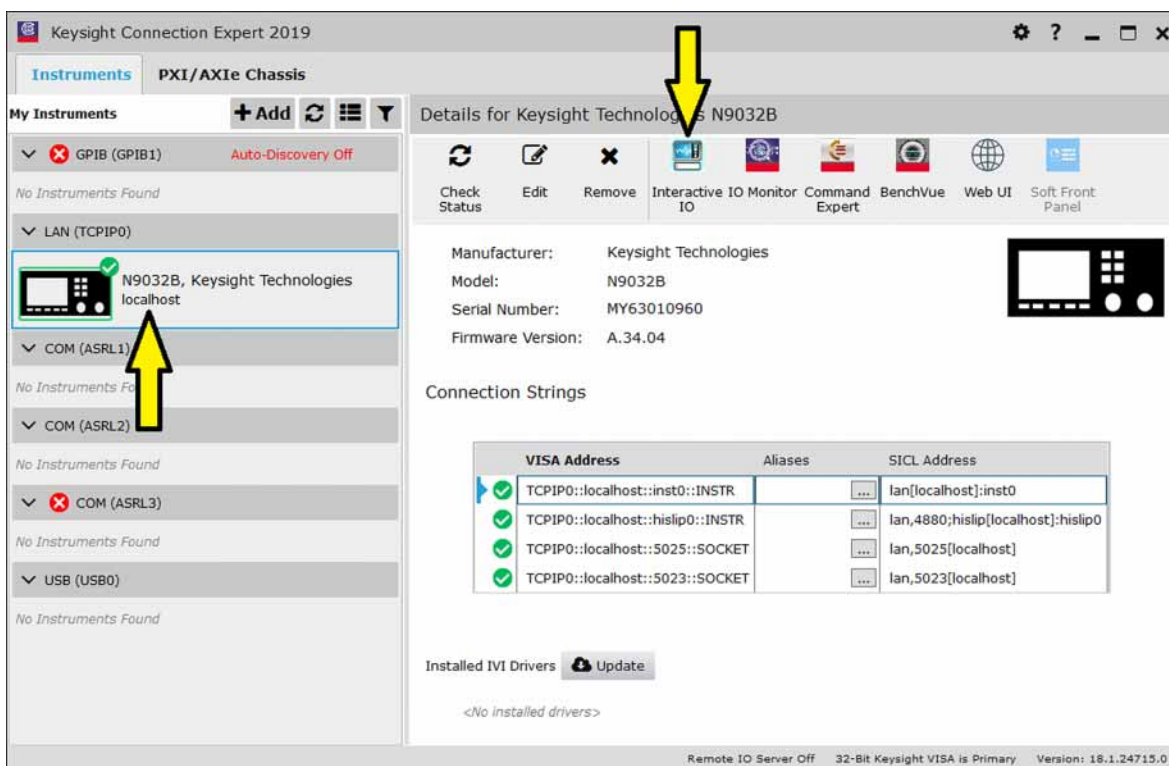
1. Connect a USB keyboard and mouse to the instrument.
2. Change the instrument mode and measurement to IQ Analyzer mode and the Streaming measurement by pressing **Mode/Meas, IQ Analyzer, Streaming, OK**.
3. Insert the Loopback Dongle that is included with this kit (M8121-60004) into the rear panel ODI port with the alignment tab pointing up, making sure that it positively snaps into place.

### NOTE

It is very important that the dongle is correctly inserted all the way into the rear panel ODI port. It must click into place such that it cannot be removed without sliding the spring loaded latch to release it.

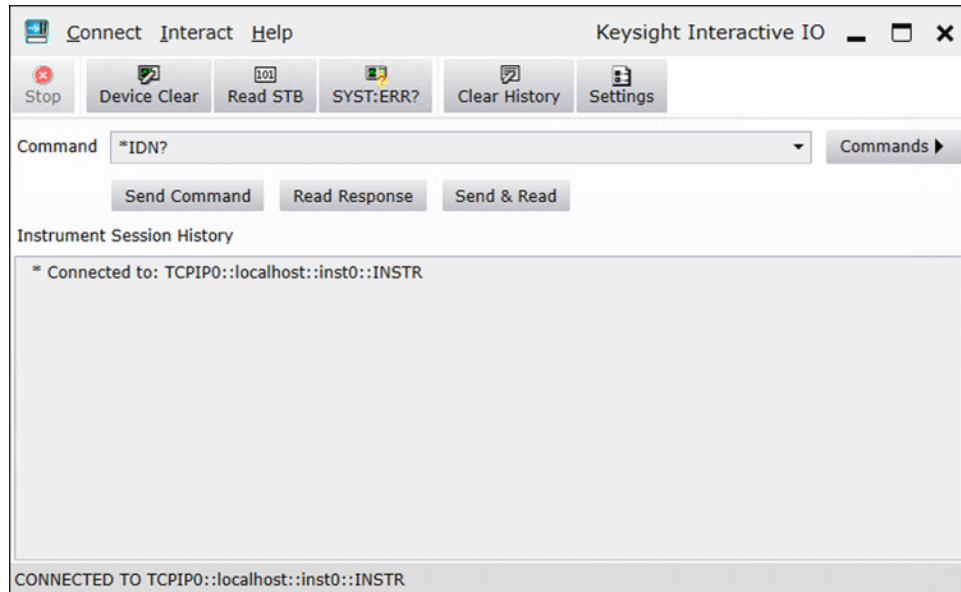
4. Using the USB mouse, select **Start, Keysight Connection Expert**. You should then see the connection expert, as seen in **Figure 31**.

**Figure 31** Keysight Connection Expert



5. Select the instrument listed as **localhost**, then select **Interactive IO** for it. You will then see the Interactive IO window for the instrument, as seen in **Figure 32**.

**Figure 32** Interactive IO



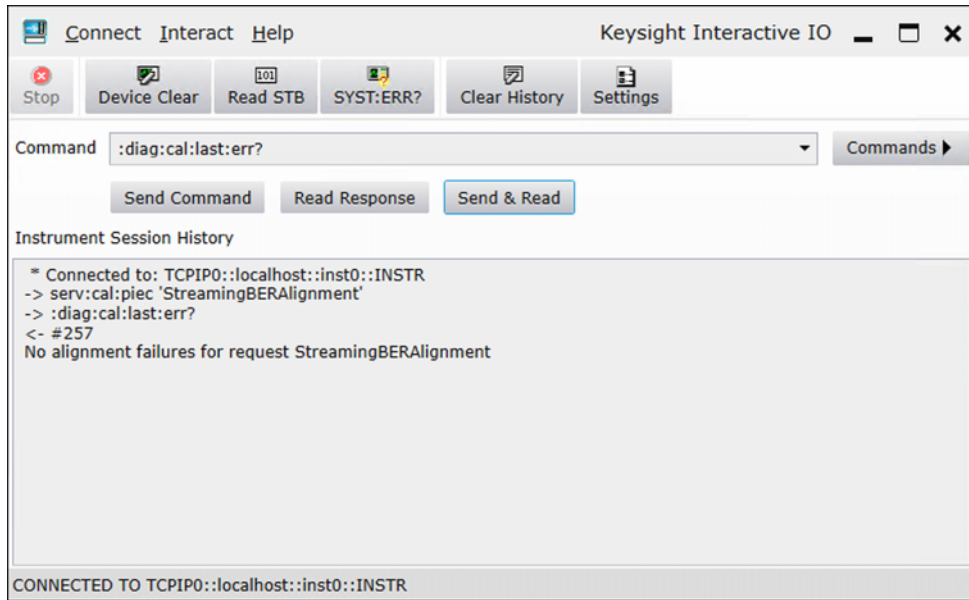
6. To run the test, type the following command into the **Command** field:  
:serv:cal:piec 'StreamingBERAlignment'
7. Press **Send Command**.
8. To verify that the test passed, type the following into the **Command** field:  
:diag:cal:last:err?
9. Press **Send & Read**.

Option S01 and S02 – IQ Streaming

10. As seen in **Figure 33**, the response from the instrument should include:

No alignment failures for request StreamingBERAlignment

**Figure 33** Loopback Test Results



If the test shows a failure, make sure that the loopback dongle is properly inserted into the rear panel ODI port.



This information is subject to change without notice.

© Keysight Technologies 2023-2024

Edition 2, December 2024

N9032-90011

[www.keysight.com](http://www.keysight.com)