

---

# X-Series Signal Analyzer

N9042B

Power Supply Upgrade

Option HW1

# Notices

© Copyright 2023-2024 Keysight Technologies, Inc.

The information contained in this document is subject to change without notice.

Keysight Technologies makes no warranty of any kind with regard to this material, including but not limited to, the implied warranties of merchantability and fitness for a particular purpose.

Keysight Technologies shall not be liable for errors contained herein or for incidental or consequential damages in connection with the furnishing, performance, or use of this material.

## **Manual Part Number**

N9042-90012

## **Edition**

Edition 1, January 2024

Supersedes: January 2023

Printed in USA/Malaysia

Published by:

Keysight Technologies, Inc.  
1400 Fountaingrove Parkway  
Santa Rosa, CA 95403

## Option HW1 – Power Supply Upgrade

Products Affected:	UXA N9042B
To Be Performed By:	(X) Keysight Service Center (X) Advanced User ( ) User
Estimated Installation Time:	2.0 Hours
Estimated Adjustment Time:	0.0 Hours
Estimated Verification Time:	1.0 Hours

This document provides detailed instructions for the installation of the Power Supply upgrade for the N9042B UXA Signal Analyzer.

Please be sure to read this entire document before attempting to perform this upgrade. Then, be sure to perform the steps in this procedure in the order that they are listed so that the installation will complete properly, and the instrument will function as desired when completed.

### Compatibility

This instrument option requires no specific instrument firmware version and is compatible with all N9042B instruments. However, all instruments with option G2H do not require this upgrade, they include it from the factory.

### Instrument Calibration

The validity of any existing calibration that the instrument being upgraded may have will not be affected by the installation of this upgrade.

## What You Will Find in this Document

ESD Information.....	page 5
Upgrade Contents .....	page 7
Tools Required .....	page 7
Initial Instrument Functionality Check .....	page 8
Option G2H Check.....	page 8
Option ST1/ST2 Check.....	page 8
Option R40 Check.....	page 8
Upgrade Instructions.....	page 9
Hardware Removal .....	page 9
Hardware Installation .....	page 20
Verify Operation .....	page 29
Instrument Button Up.....	page 30
Rear Panel Labels .....	page 31
Adjustments and Performance Verification.....	page 32
Manual Procedures Required.....	page 32
Automated Utilities Required.....	page 32
Automated Adjustments Required .....	page 32
Automated Performance Verification Testing Required .....	page 32

## ESD Information

### Protection from Electrostatic Discharge

Electrostatic discharge (ESD) can damage or destroy electronic components. All work on electronic assemblies should be performed at a static-safe workstation. **Figure 1** shows an example of a static-safe workstation using two types of ESD protection:

- Conductive table-mat and wrist-strap combination.
- Conductive floor-mat and heel-strap combination.

Both types, when used together, provide a significant level of ESD protection. Of the two, only the table-mat and wrist-strap combination provides adequate ESD protection when used alone. To ensure user safety, the static-safe accessories must provide at least 1 megohm of isolation from ground.

#### WARNING

These techniques for a static-safe workstation should not be used when working on circuitry with a voltage potential greater than 500 volts.

**Figure 1** Example of a Static-Safe Workstation

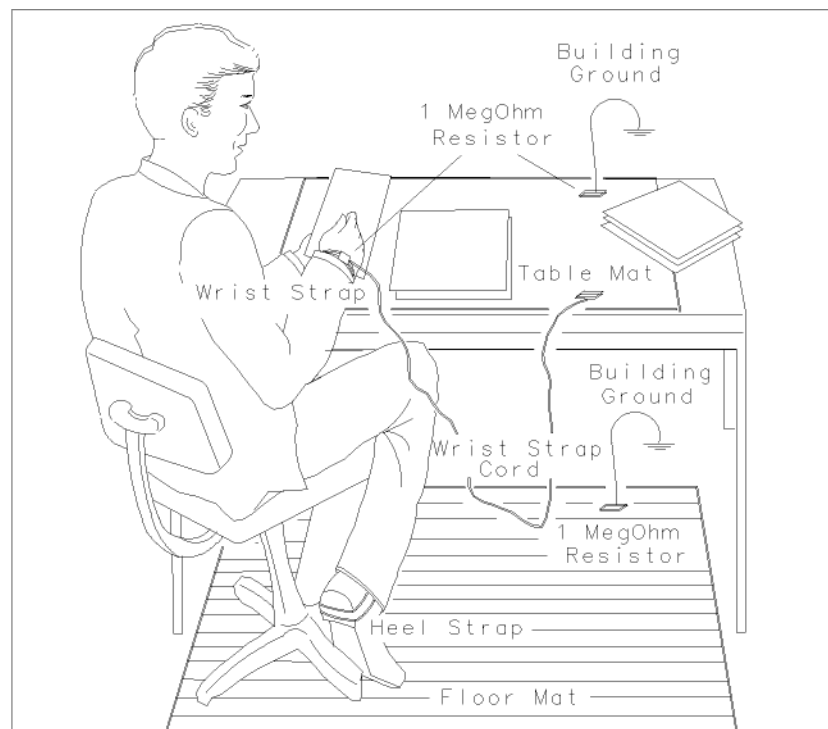

## ESD Information

### Handling of Electronic Components and ESD

The possibility of unseen damage caused by ESD is present whenever components are transported, stored, or used. The risk of ESD damage can be greatly reduced by paying close attention to how all components are handled.

- Perform work on all components at a static-safe workstation.
- Keep static-generating materials at least one meter away from all components.
- Store or transport components in static-shielding containers.

#### **CAUTION**

Always handle printed circuit board assemblies by the edges. This will reduce the possibility of ESD damage to components and prevent contamination of exposed plating.

---

### Test Equipment Usage and ESD

- Before connecting any coaxial cable to an analyzer connector, momentarily short the center and outer conductors of the cable together.
- Personnel should be grounded with a 1 megohm resistor-isolated wrist-strap before touching the center pin of any connector and before removing any assembly from the analyzer.
- Be sure that all analyzers are properly earth-grounded to prevent build-up of static charge.

### For Additional Information about ESD

For more information about preventing ESD damage, contact the Electrical Over Stress/Electrostatic Discharge (EOS/ESD) Association, Inc. The ESD standards developed by this agency are sanctioned by the American National Standards Institute (ANSI).

## Upgrade Contents

Table 1 Upgrade Contents

Part Number	Description	Quantity
0515-0372	Screw, Panhead, TORX-T10 M3X0.5 8mm-LG	6
0515-1946	Screw, Flathead, TORX-T10 M3X0.5 6mm-LG	18
0515-2032	Screw, Flathead, TORX-T10 M3X0.5 8mm-LG	9
0515-2151	Screw, Flathead, TORX-T6 M2X0.4 4mm-LG	1
0535-0031	Nut-HEX W/Lock-Washer M3X0.5	2
0950-6424	Power Supply, AC-DC Switching, 695 W	1
N9041-00043	Rear Frame	1
N9041-00050	Blank Cover	1
N9041-00052	Nut Plate	1
N9042-80007	Label, KCC, 1220705	1

This upgrade kits includes a new higher capacity power supply assembly to replace the existing one. This kit is intended to be used when the owner of the instrument has requested to have the power capacity increased for one of the power intensive wideband measurement applications that require it.

## Tools Required

- TORX Driver, T-10
- TORX Driver, T-20
- Nut Driver, 5.5 mm
- Multi-Bit Torque Driver
- 5/8" Nut Driver
- 5/16" Wrench

## Initial Instrument Functionality Check

### Initial Instrument Functionality Check

Power on the instrument and allow it to complete its boot up process. Verify that there are no instrument messages that would indicate that there is an issue with either the instrument hardware or software. If there are any issues, investigate and fix the problem before continuing with this upgrade.

#### Option G2H Check

While the instrument is still powered on check to see if the instrument has Option G2H installed. To do so press **System, Show System** and look on the System Information screen for Option **G2H**.

If the instrument has Option G2H installed it does not need this upgrade, as it should already have this hardware installed.

#### Option ST1/ST2 Check

While the instrument is still powered on check to see if the instrument has Option ST1 or ST2 installed. To do so press **System, Show System** and look on the System Information screen for Option **ST1** or **ST2**. Note whether one of these options is installed or not below.

**Option ST1 or ST2 Installed:** \_\_\_\_\_ Yes \_\_\_\_\_ No

#### Option R40 Check

While the instrument is still powered on check to see if the instrument has Option R40 installed. To do so press **System, Show System** and look on the System Information screen for Option **R40**. Note whether Option R40 is installed or not below.

**Option R40 Installed:** \_\_\_\_\_ Yes \_\_\_\_\_ No

The following procedure will ask you to make decisions based on whether or not these options are installed in the instrument.

# Upgrade Instructions

## Hardware Removal

### Dress Cover Removal

1. Turn the instrument off and disconnect the power cord.
2. Referring to **Figure 2**, remove the two screws (1) that attach the strap handles (2) from both sides of the instrument and remove the strap handles.

**Figure 2** Dress Cover Removal

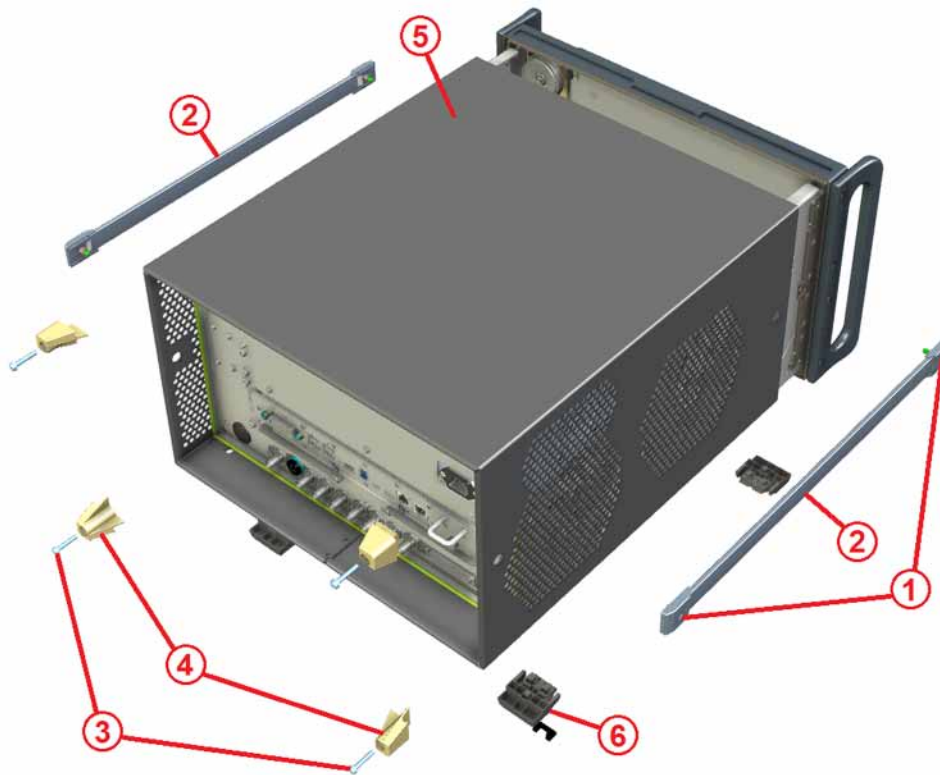

3. Remove the four rear feet (4) by removing the four screws (3) and washers that attach them.
4. Remove the four bottom feet (6) by first removing the locking keys and then lifting the tabs and sliding the foot toward the tabs.
5. Carefully slide the dress cover (5) off the instrument. This dress cover will not be reused.

## Upgrade Instructions

### Top Brace Removal

6. Referring to **Figure 3**, remove the fourteen flathead screws (1) and three panhead screws (2) attaching the top brace (3) to the instrument and set it aside.

**Figure 3** Top Brace Removal

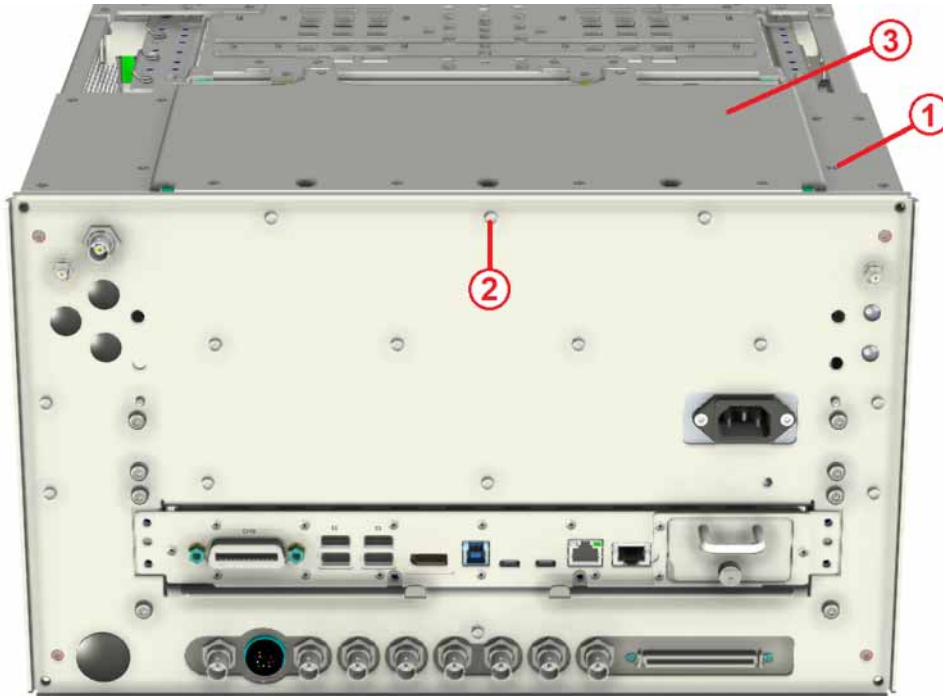

## Rear Panel Removal

7. If the instrument has Option ST1 or ST2, remove the four panhead screws (1) that attach the power supply adapter plate (2) to the rear panel, as seen in **Figure 4**. This plate can be discarded.

**Figure 4** Power Supply Adapter Plate Removal - Option ST1 or ST2

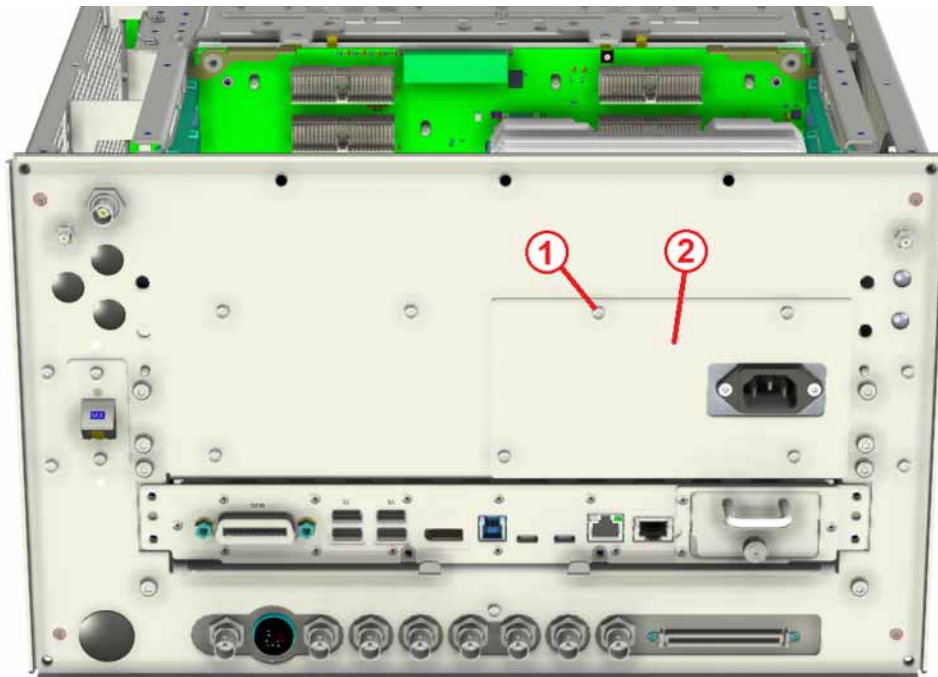

8. Referring to **Figure 5**, remove the four flathead screws (1) at the corners, the eight large panhead screws (3), and the twelve panhead screws (2) that attach the rear panel to the instruments.

**Figure 5** Rear Panel Removal

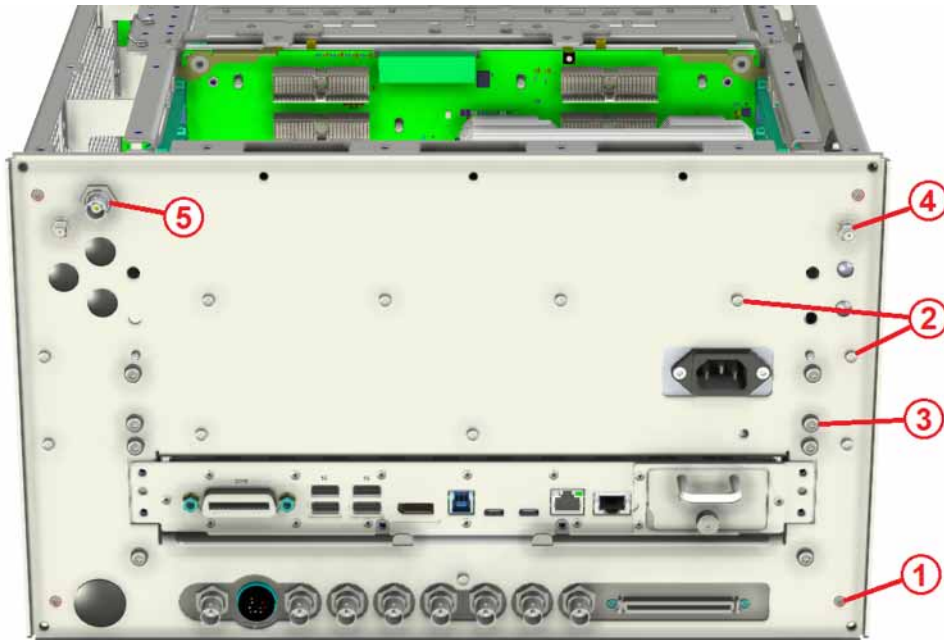

9. Remove the nuts and lock washers from the two SMA connectors (4), and the nut and lock washer from the BNC connector (5).

10. Referring to **Figure 6**, if the instrument has Option ST1 or ST2, carefully remove the ODI cable (1) from the rear panel ODI connector (2) by sliding the locking tab up.

**Figure 6** Rear Panel ODI Cable Removal - Option ST1 or ST2

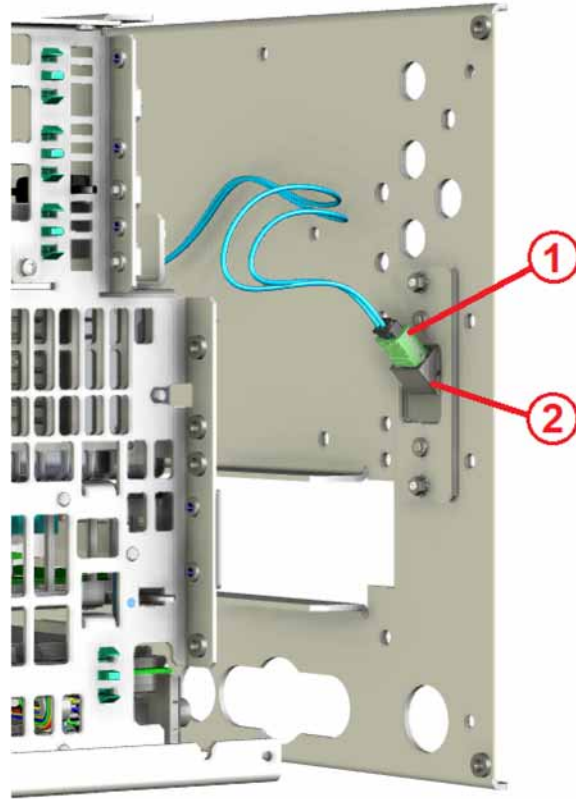

11. Carefully remove the rear panel from the instrument. If the instrument has Option ST1 or ST2 the rear panel will be reused. If not, it can be discarded.

## Rear Brace Removal

12. Referring to [Figure 7](#), remove the four panhead screws (1) and the two flathead screws (2), then remove the rear brace (3) from the instrument.

**Figure 7** Rear Brace Removal

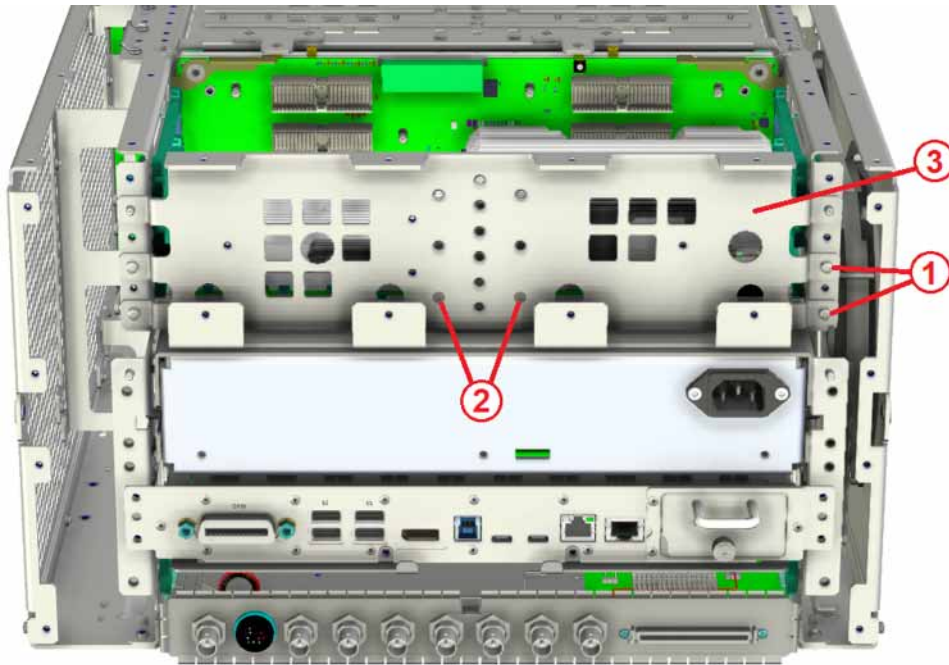

**NOTE**

If the instrument has Option ST1, ST2, or R40 the rear brace removal will also require that the optical cables also be disconnected and detached from the rear brace before it can be removed, as seen in [Figure 8](#). Be careful not to pinch or bend the optical cables too tight as they can be easily damaged.

**Figure 8** Rear Brace Removal - Optional Hardware

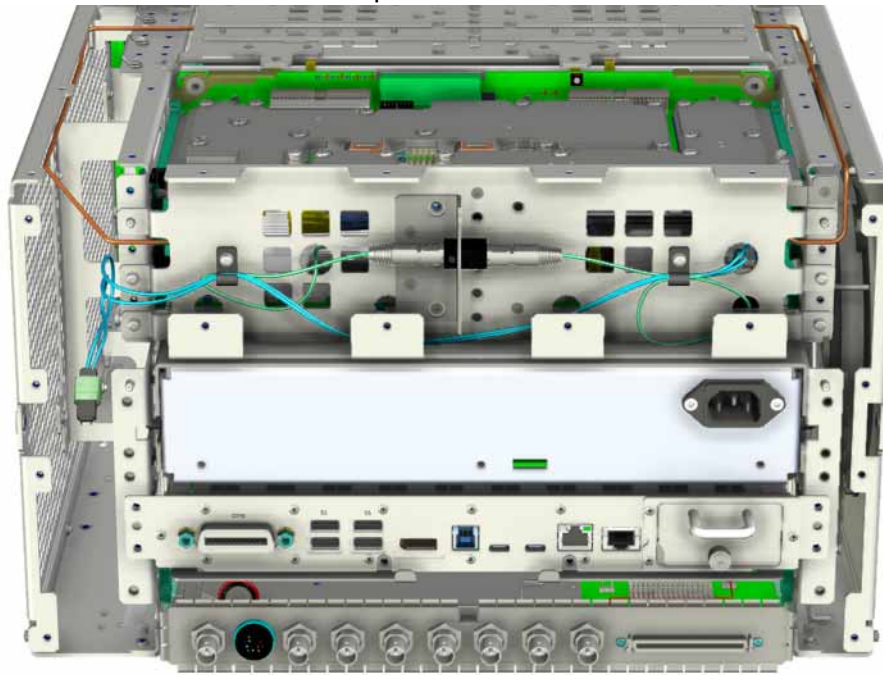

## A21 Wideband Digital IF Removal

13. Referring to [Figure 9](#), unplug all the coax cables that are connected to the A21 Wideband Digital IF assembly in the area shown (1).
14. Pull on the two board extractors (2) and remove the A21 Wideband Digital IF assembly from the instrument. Be careful not to damage any of the cables that were unplugged.

**Figure 9** A21 Wideband Digital IF Removal

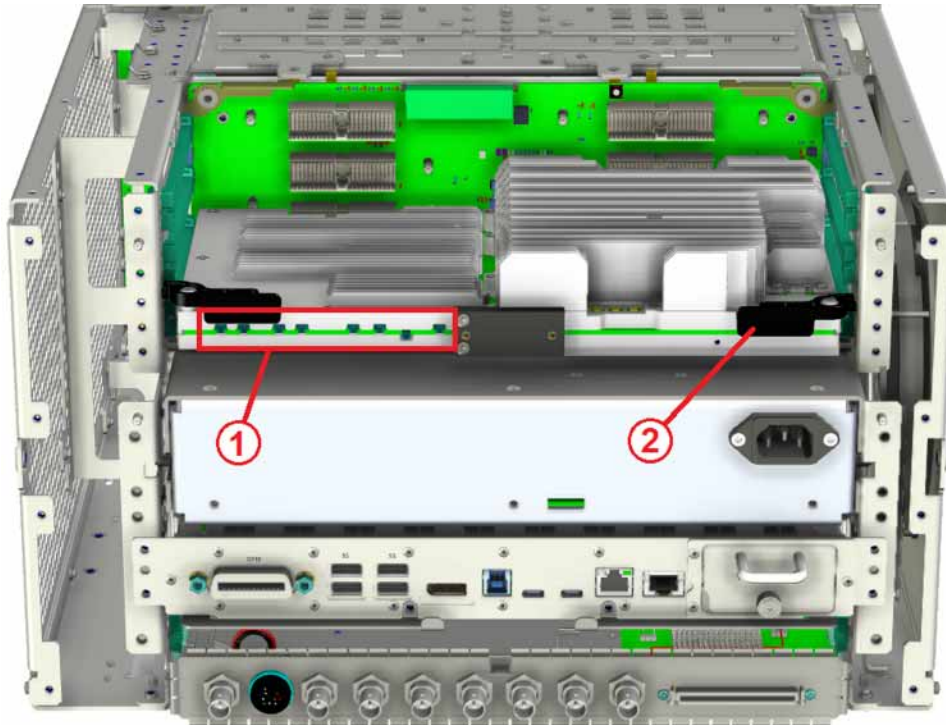

### NOTE

If the instrument has Option R40, the A22 Ultra-Wideband Analog IF will also need to be removed, as seen in [Figure 10](#). If done carefully, the cables that interconnect between these two assemblies do not need to be disconnected.

**Figure 10** A22 Ultra-Wideband Analog IF Removal - Option R40



## A4 System Processor Removal

15. Referring to **Figure 11**, remove the two panhead screws (1) from each side that attaches the A4 System Processor (3) to the instrument.
16. Remove the two panhead screws (2) that secure the extractors.
17. Remove the A4 System Processor by pulling on the two extractors and sliding it out the rear of the instrument.

**Figure 11** A4 System Processor Removal

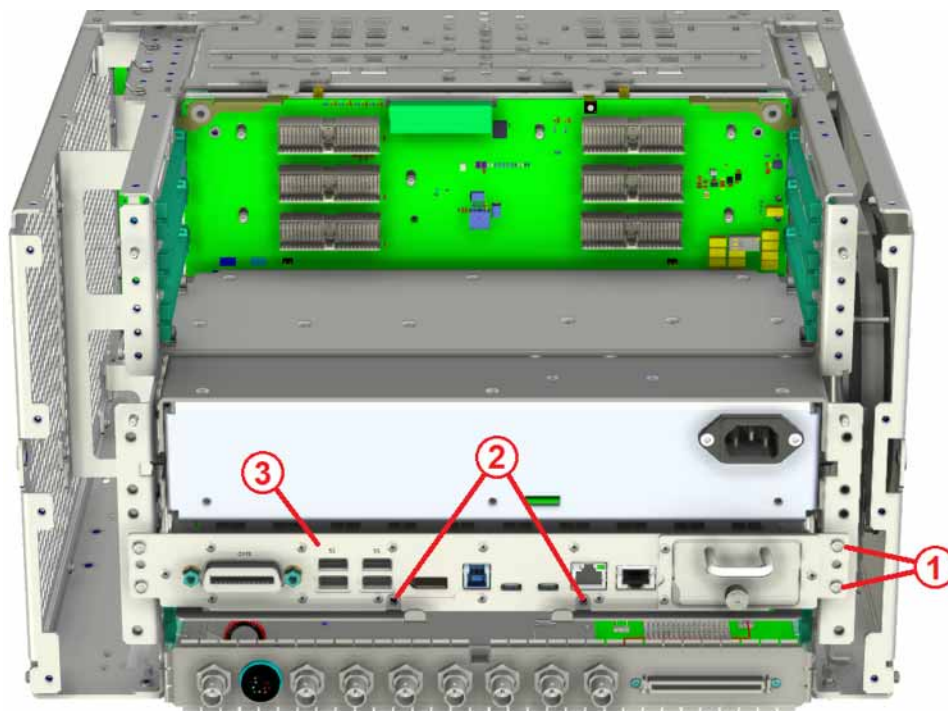

## A6 Power Supply Removal

18. Referring to **Figure 12**, remove the 9 flathead screws (1) attaching the A6 Power Supply to the instrument.
19. Slide the A6 Power Supply out the rear of the instrument and discard it.

**Figure 12** A6 Power Supply Removal

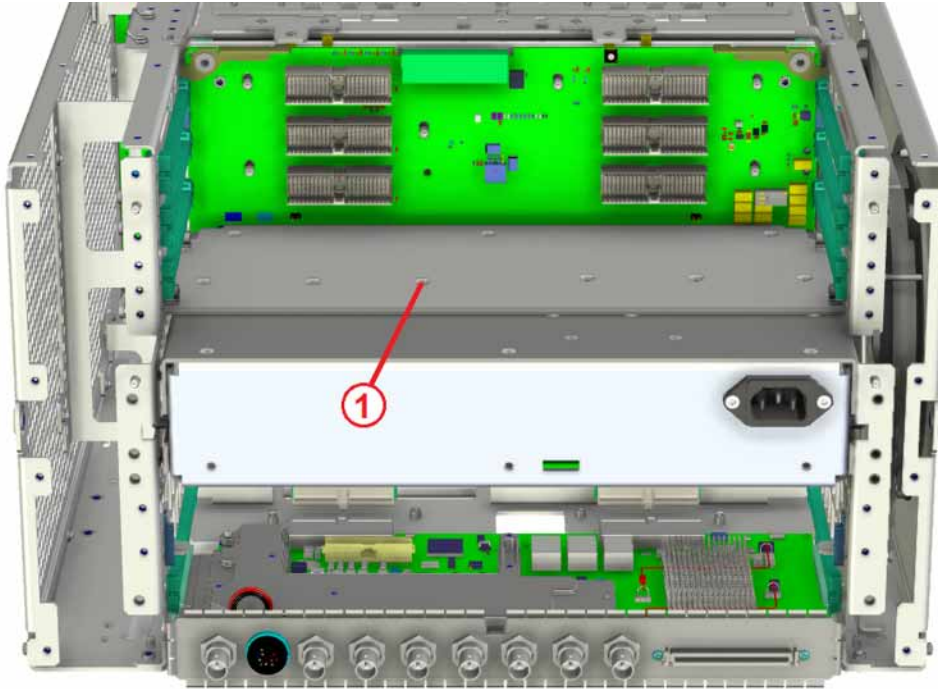

## Hardware Installation

### A6 Power Supply Installation

1. Referring to **Figure 13**, slide the new A6 Power Supply into the rear of the instrument until it fully engages the mating connectors on the A7 Midplane board.
2. Install the nine new flathead screws (0515-2032) (1) to attach the A6 Power Supply to the instrument through the power supply bracket. Torque the screws to 9 in-lbs.

**Figure 13** A6 Power Supply Installation

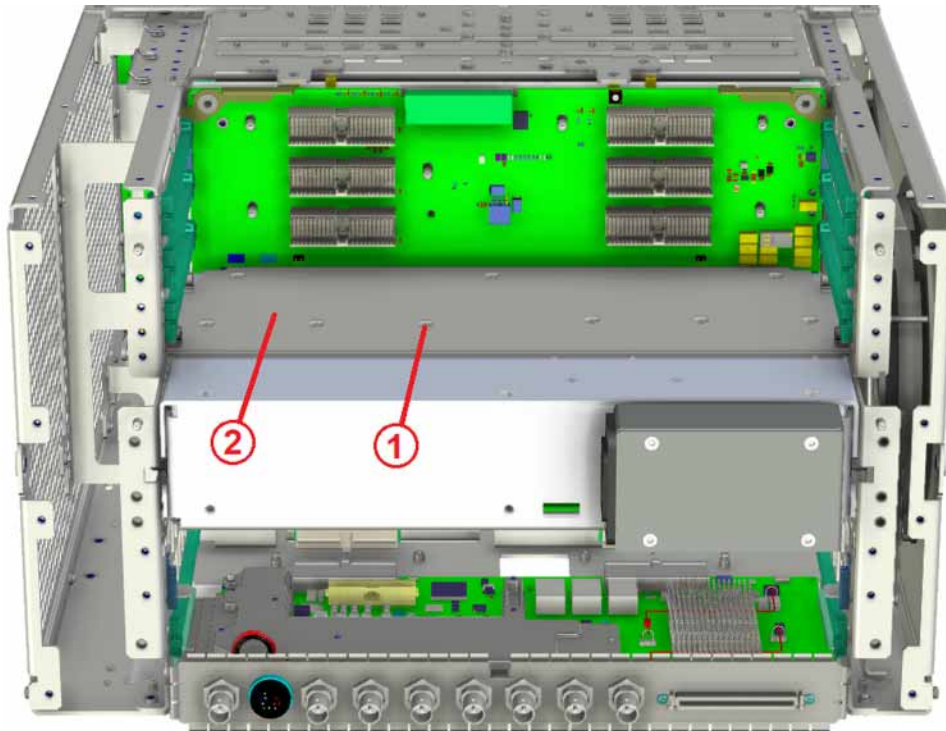

### A4 System Processor Installation

3. Referring to **Figure 14**, use the two extractors to insert the A4 System Processor (3) into the rear of the instrument.
4. Install the two panhead screws (1) on each side to attach the A4 System Processor to the instrument. Torque the screws to 9 in-lbs.
5. Install the two panhead screws (2) to attach the extractors to the A4 System Processor. Torque the screws to 9 in-lbs.

**Figure 14** A4 Processor Installation

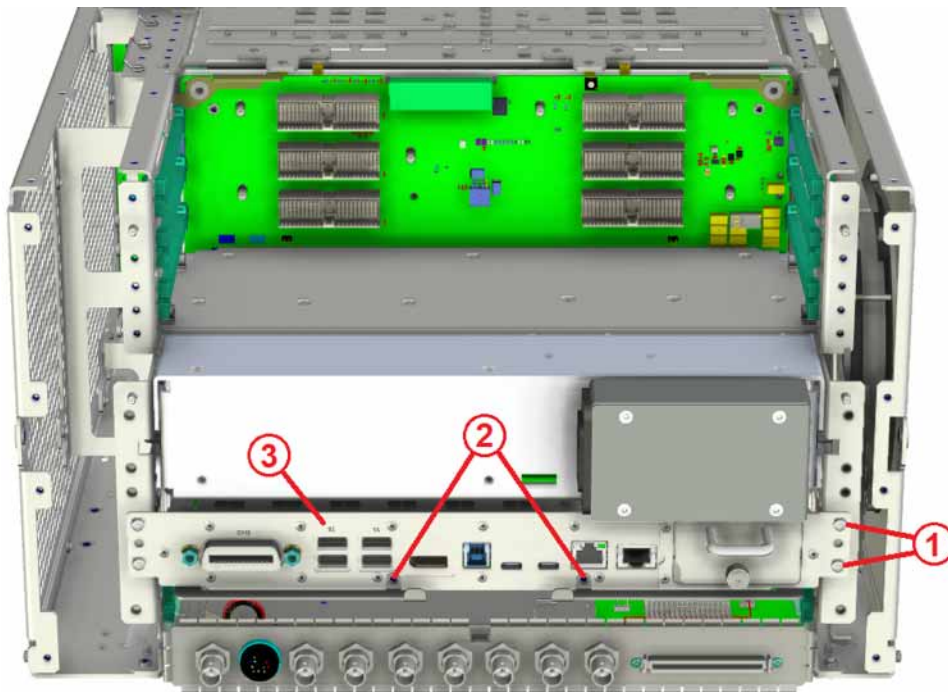

## A21 Wideband Digital IF

6. Referring to [Figure 15](#), use the extractors (2) to insert the A21 Wideband Digital IF back into the instrument, being careful not to damage any of the coax cables that attach to it.
7. Reconnect the coax cables to their corresponding connectors on the A21 Wideband Digital IF.

**Figure 15** A21 Wideband Digital IF Installation

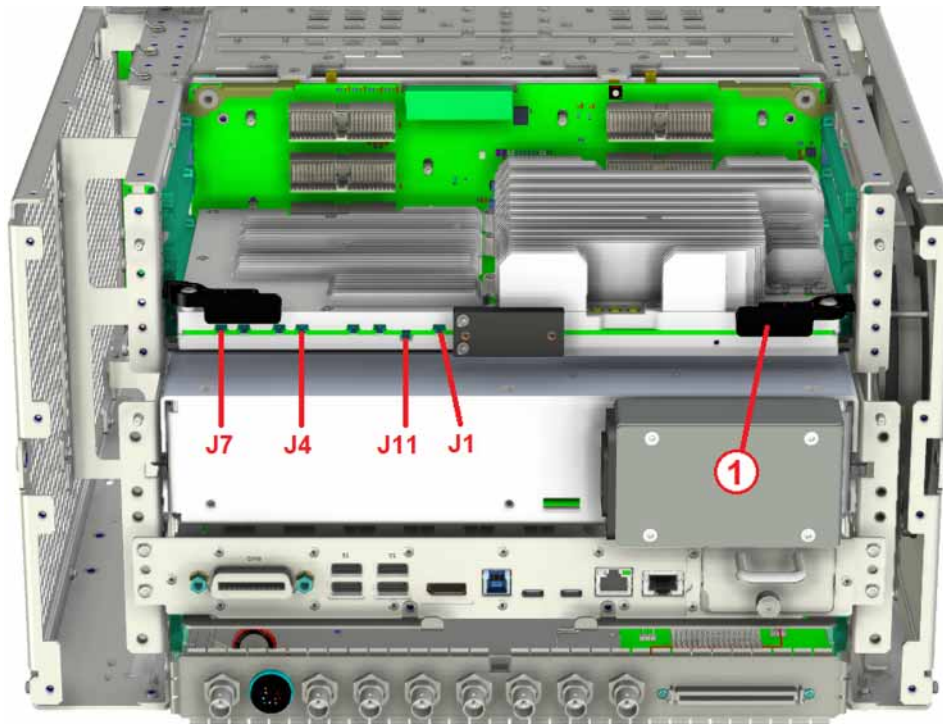

**NOTE**

If the instrument has Option R40, the A22 Ultra-Wideband Analog IF will also need to be installed, as seen in [Figure 16](#).

**Figure 16** A22 Ultra-Wideband Analog IF Installation - Option R40

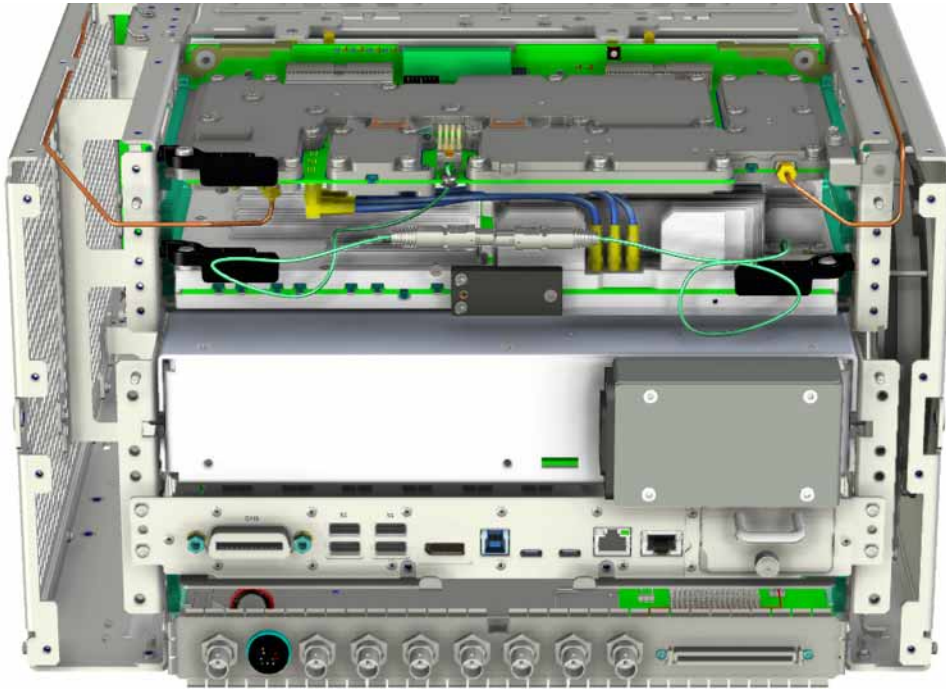

## Rear Brace Installation

8. Referring to **Figure 17**, install the rear brace (3) and attach it to the chassis with two panhead screws (1) on each end. Torque the screws to 9 in-lbs.
9. Attach the rear brace to the A21 Wideband Digital IF with the two flathead screws (2). Torque the screws to 9 in-lbs.

**Figure 17** Rear Brace Installation

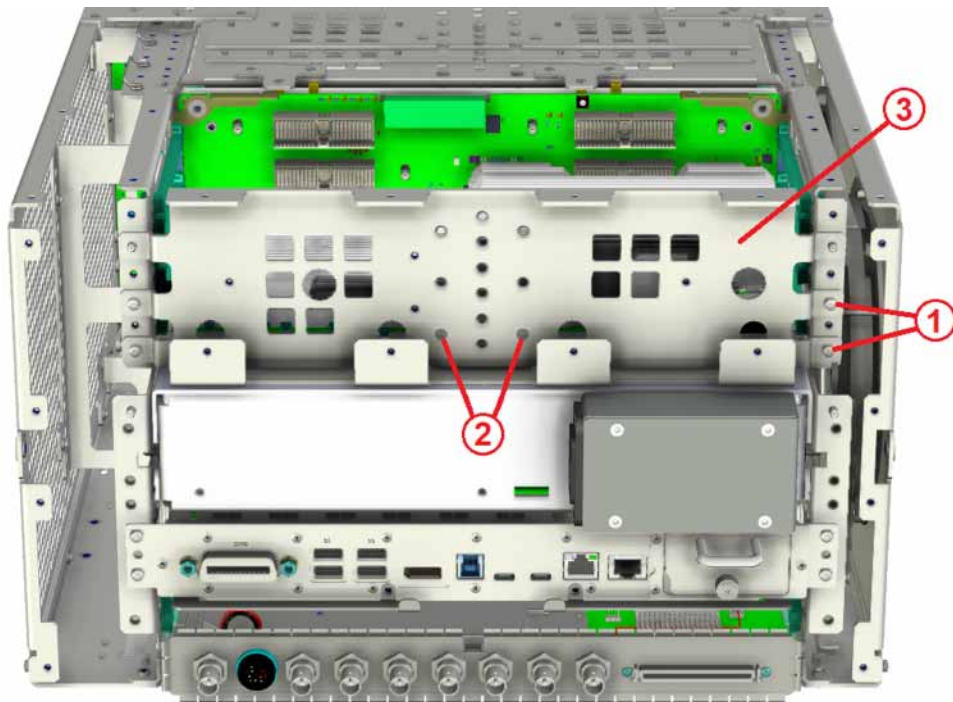

### NOTE

If the instrument has Option ST1, ST2, or R40 the rear brace installation will also require that the optical cables also be connected and attached to the rear brace once it is installed, as seen in **Figure 18**. Be careful not to pinch or bend the optical cables too tight as they can be easily damaged.

**Figure 18** Rear Brace Installation - Optional Hardware

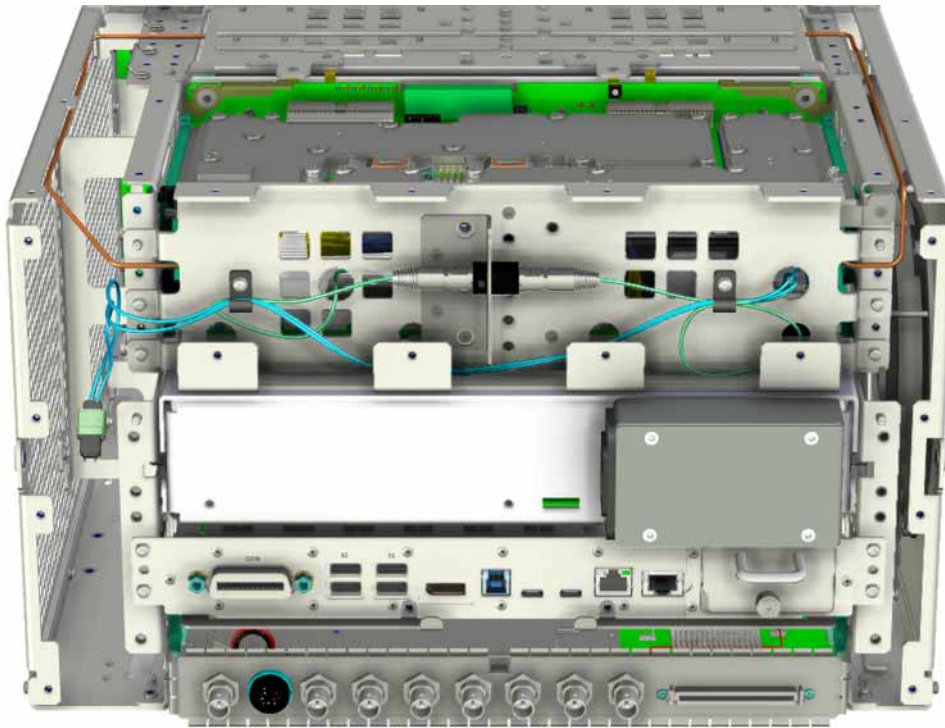

## Rear Panel Installation

**NOTE**

If the instrument has Option ST1 or ST2 the original rear panel will be reused to avoid having to move the serial number label or the rear panel optical connector to the new one.

10. If the instrument does not have Option ST1 or ST2, attach the nut plate (1) to the rear frame using the two hex nuts (2), as seen in **Figure 19**. Torque the nuts to 9 in-lbs.
11. Attach the blank cover (3) to the rear frame using the two panhead screws (4). Torque the screws to 9 in-lbs.

**Figure 19** Optical Port Blank Cover Installation

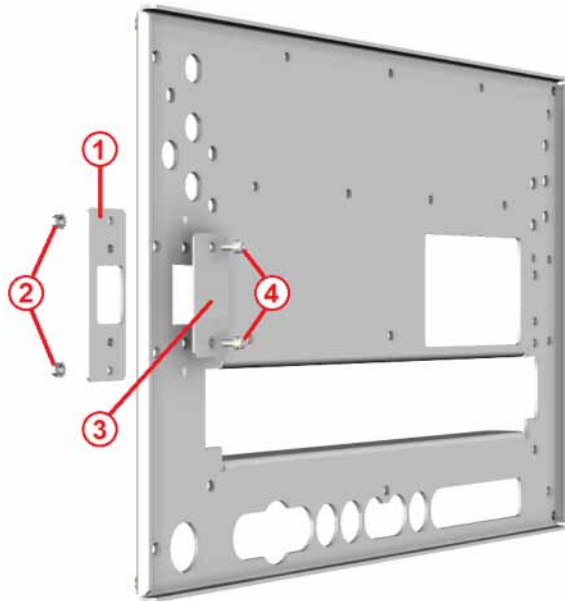

12. If the instrument has Option ST1 or ST2, connect the optical cable (1) to the rear panel optical connector (2), as seen in **Figure 20**. Be sure to insert it all the way, until a click is heard.

**Figure 20** Rear Panel Installation - Optional Hardware

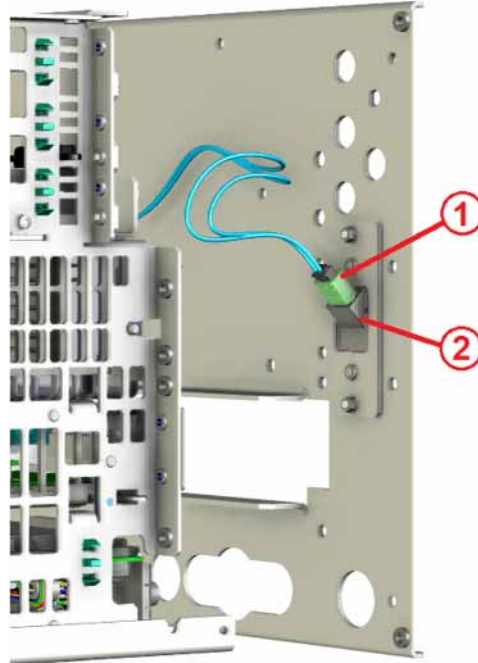

- Referring to **Figure 21**, feed the two SMA cables (4) and the one BNC cable (5) through the new rear panel and attach them with their lock washers and hex nuts. Torque the SMA cable hex nuts to 10 in-lbs and the BNC hex nut to 21 in-lbs.

**Figure 21** Rear Panel Installation

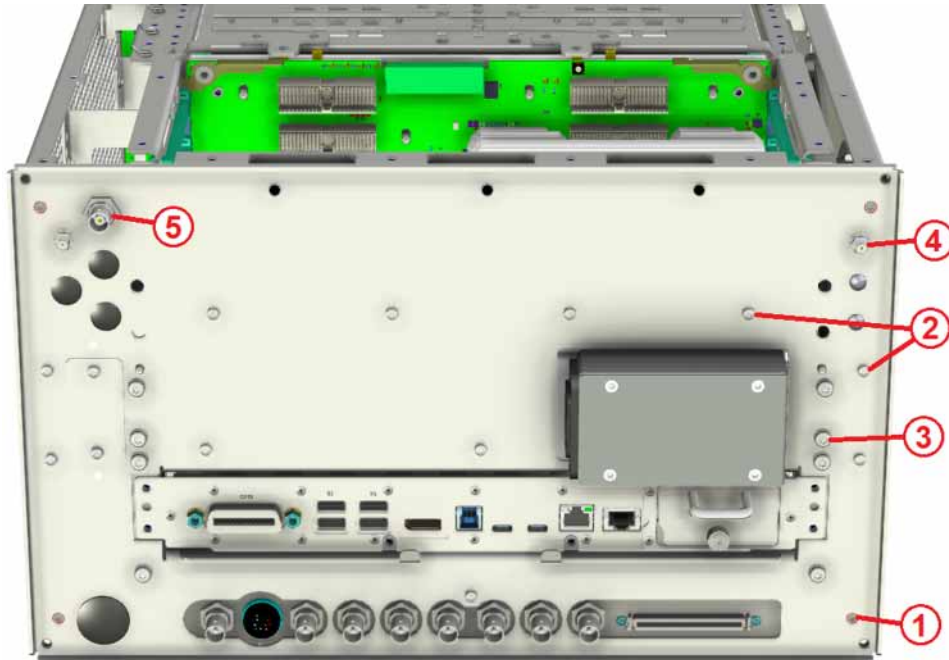

- Install the rear panel onto the instrument and secure it with the eight M4.0 panhead screws (3), the eleven M3.0 panhead screws (2), and the four new M3.0 flathead screws (1). Torque the M3.0 screws to 9 in-lbs. and the M4.0 screws to 21 in-lbs.

## Top Brace Installation

15. Referring to **Figure 22**, install the top brace (3) using the fourteen new flat screws (1) and the three panhead screws (2). Torque all screws to 9 in-lbs.

**Figure 22** Top Brace Installation

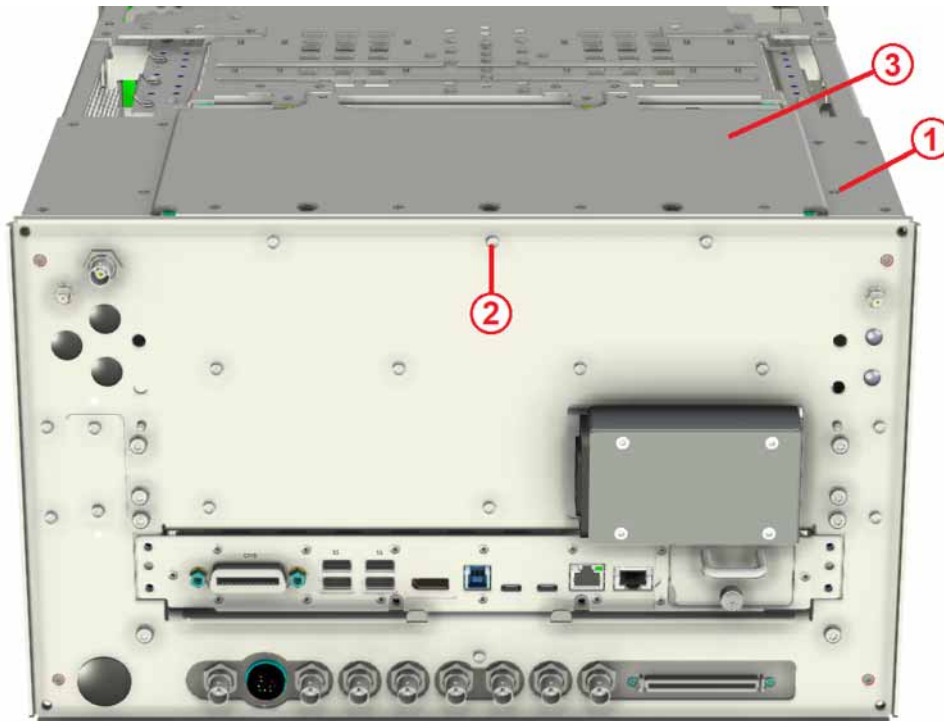

## Verify Operation

The operation of the power supply should be verified before installing the instrument dress cover.

1. Connect the AC mains to the instrument and turn it on.
2. Verify that the cooling fans come right on and that the instrument boots up properly.
3. Turn the instrument off and remove the AC mains.

### Dress Cover Installation

1. Referring to **Figure 22**, carefully slide the outer cover (5) onto the instrument.

**Figure 23** Dress Cover Installation

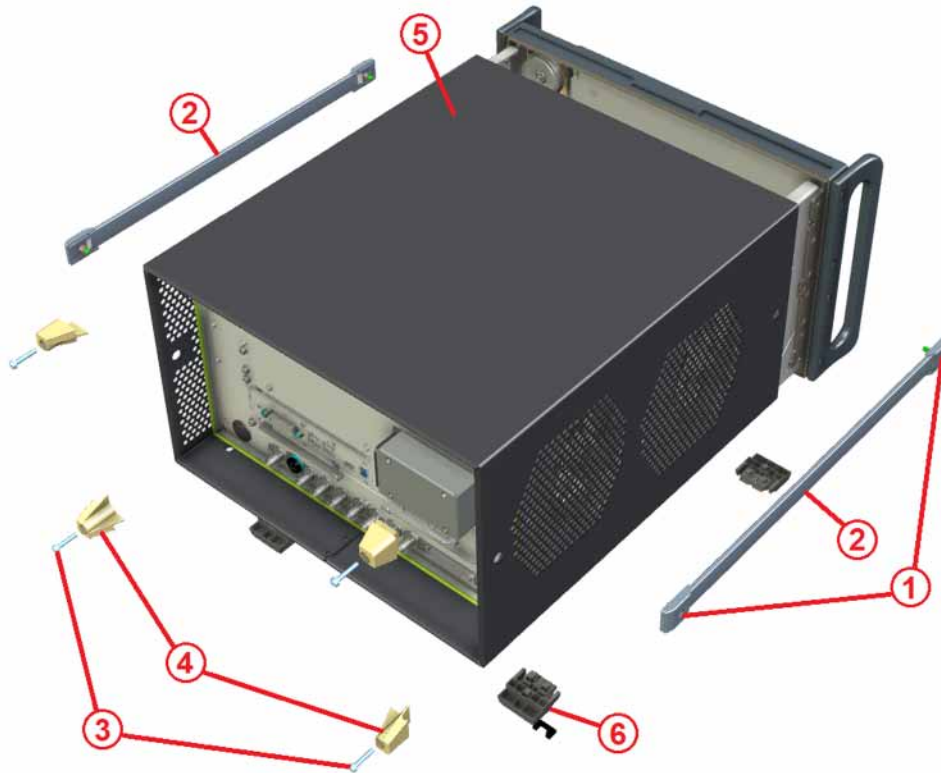

2. Attach the four rear feet (4) using the four panhead screws and washers (3). Torque the screws to 21 in-lbs.
3. Install the four bottom feet (6) along with the locking keys.
4. Install the strap handles (2) to both sides of the instrument using the two screws (1) at either end of the handles. Torque the screws to 21 in-lbs.

## Rear Panel Labels

If the instrument that was upgraded does not have Option ST1 or ST2 the rear panel will have been changed during the upgrade process and will need to have two rear panel labels attached to it. These would be the following:

1. Serial Number Label
2. KCC Certification Label

### Serial Number Label

If the rear panel was changed during this upgrade, the serial number label will need to be carefully transferred from the original rear panel to the new one. The serial number label needs to be attached in the area outlined in **Figure 24**.

### KCC Certification Label

The new KCC certification label provided with this upgrade needs to be affixed to the new rear panel in the area outlined in **Figure 24**

**Figure 24** Rear Panel Label Locations

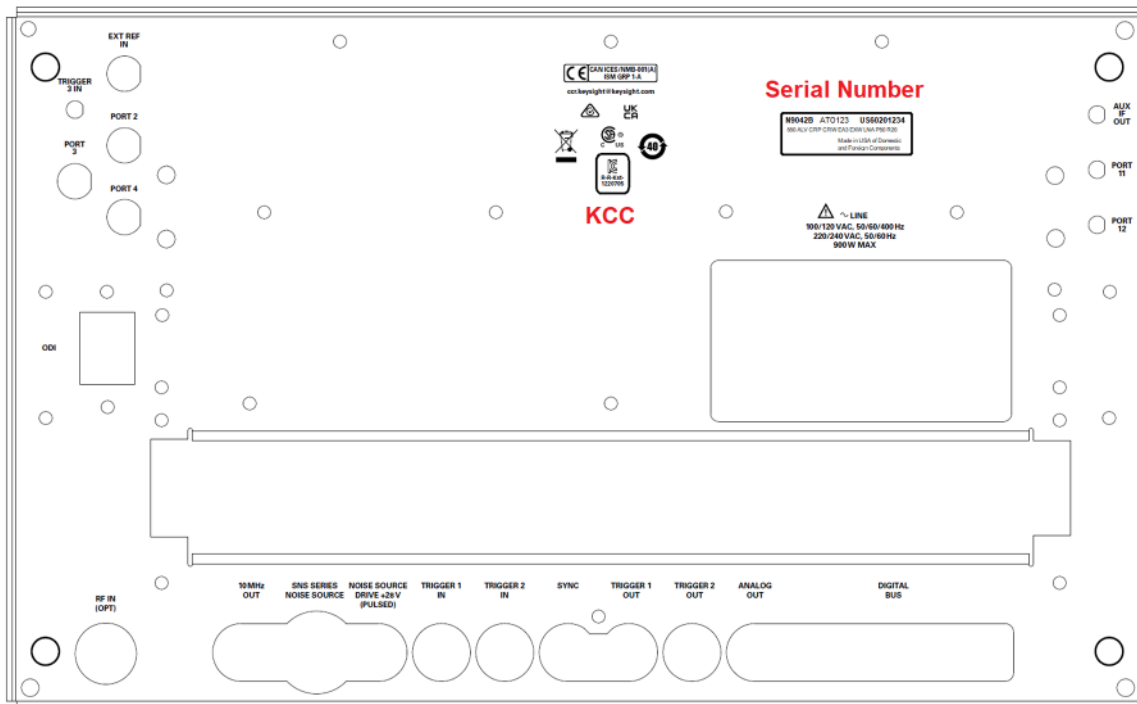

Adjustments and Performance Verification

## Adjustments and Performance Verification

Manual Procedures Required

None

Automated Utilities Required

None

Automated Adjustments Required

None

Automated Performance Verification Testing Required

Noise Density

Residual Response

Displayed Average Noise Level

Spurious Responses

IF Frequency Response

IF Amplitude Accuracy



This information is subject to change without notice.

© Keysight Technologies 2023-2024

Edition 1, January 2024

N9042-90012

[www.keysight.com](http://www.keysight.com)