

---

# Keysight X-Series Signal Analyzer

N9042B

IQ Streaming

Option ST1 and ST2

# Notices

© Copyright 2023-2024 Keysight Technologies, Inc.

The information contained in this document is subject to change without notice.

Keysight Technologies makes no warranty of any kind with regard to this material, including but not limited to, the implied warranties of merchantability and fitness for a particular purpose.

Keysight Technologies shall not be liable for errors contained herein or for incidental or consequential damages in connection with the furnishing, performance, or use of this material.

## **Manual Part Number**

N9042-90011

## **Edition**

Edition 1, December 2024

Supersedes: January 2023

Printed in USA/Malaysia

Published by:

Keysight Technologies, Inc.  
1400 Fountaingrove Parkway  
Santa Rosa, CA 95403

## Option ST1 and ST2 – IQ Streaming

Products Affected:	UXA N9042B
To Be Performed By:	(X) Keysight Service Center ( ) Advanced User ( ) User
Estimated Installation Time:	2.0 Hours
Estimated Adjustment Time:	0.0 Hours
Estimated Verification Time:	1.0 Hours

This document provides detailed instructions for the installation of the IQ Streaming upgrades for the N9042B UXA Signal Analyzer.

Please be sure to read this entire document before attempting to perform this upgrade. Then, be sure to perform the steps in this procedure in the order that they are listed so that the installation will complete properly, and the instrument will function as desired when completed.

### Compatibility

This instrument option requires that the instrument has firmware version A.34.00 or newer. If the instrument being upgraded does not currently meet this requirement the following procedure includes a step to update it.

### Instrument Calibration

The validity of any existing calibration that the instrument being upgraded may have will not be affected by the installation of this upgrade.

What you will find in this document

ESD Information.....	page 5
Upgrade Contents.....	page 7
Tools Required.....	page 8
Initial Instrument Functionality Check .....	page 8
Instrument Software Revision Check .....	page 8
Instrument Configuration Determination .....	page 9
Option G2H Check.....	page 9
Option R40 Check.....	page 9
Installed Power Supply Check.....	page 9
Determine Instrument Configuration .....	page 9
Upgrade Instructions.....	page 10
Hardware Disassembly.....	page 10
ODI Cable Installation.....	page 18
Rear Panel Configuration and Installation .....	page 31
Instrument Button Up .....	page 41
Rear Panel Labels .....	page 43
Instrument Software Installation .....	page 45
License Key Retrieval and Installation .....	page 45
Extra Parts .....	page 46
Adjustments and Performance Verification.....	page 47
Manual Procedures Required.....	page 47
Automated Utilities Required.....	page 47
Automated Adjustments Required .....	page 47
Automated Performance Testing Required .....	page 47
ODI Loopback Test.....	page 48

## ESD Information

**Protection from Electrostatic Discharge**

Electrostatic discharge (ESD) can damage or destroy electronic components. All work on electronic assemblies should be performed at a static-safe workstation. **Figure 1** shows an example of a static-safe workstation using two types of ESD protection:

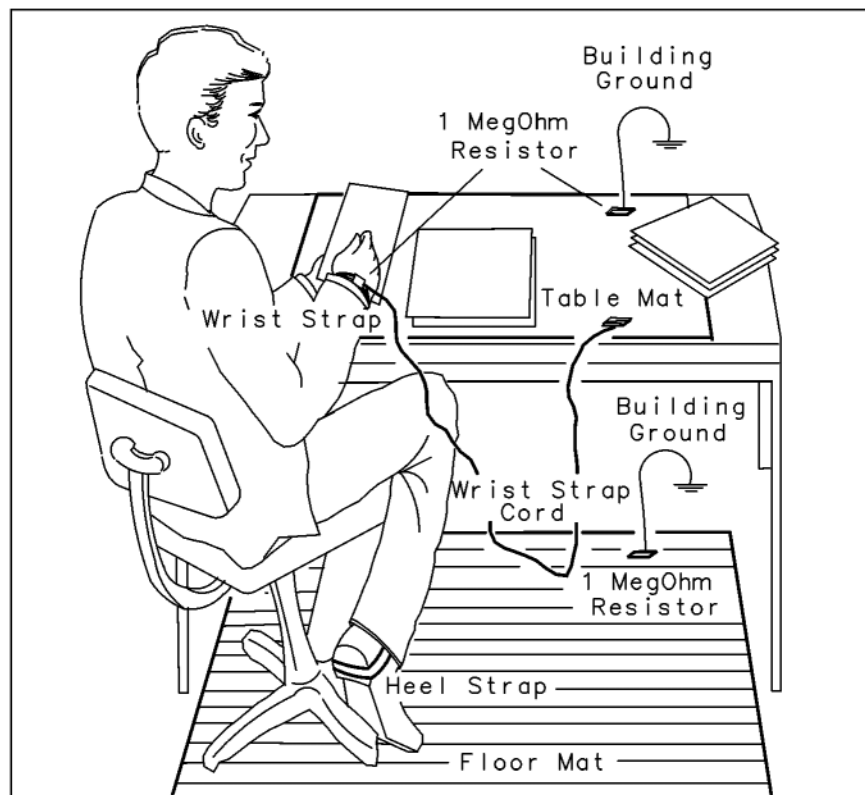
- Conductive table-mat and wrist-strap combination.
- Conductive floor-mat and heel-strap combination.

Both types, when used together, provide a significant level of ESD protection. Of the two, only the table-mat and wrist-strap combination provides adequate ESD protection when used alone. To ensure user safety, the static-safe accessories must provide at least 1 megohm of isolation from ground.

**WARNING**

These techniques for a static-safe workstation should not be used when working on circuitry with a voltage potential greater than 500 volts.

**Figure 1** Example of a Static-Safe Workstation

**Handling of Electronic Components and ESD**

The possibility of unseen damage caused by ESD is present whenever components are transported, stored, or used. The risk of ESD damage can be greatly reduced by paying close attention to how all components are handled.

## Option ST1 and ST2 – IQ Streaming

- Perform work on all components at a static-safe workstation.
- Keep static-generating materials at least one meter away from all components.
- Store or transport components in static-shielding containers.

### **CAUTION**

Always handle printed circuit board assemblies by the edges. This will reduce the possibility of ESD damage to components and prevent contamination of exposed plating.

---

## Test Equipment Usage and ESD

- Before connecting any coaxial cable to an analyzer connector, momentarily short the center and outer conductors of the cable together.
- Personnel should be grounded with a 1 megohm resistor-isolated wrist-strap before touching the center pin of any connector and before removing any assembly from the analyzer.
- Be sure that all analyzers are properly earth-grounded to prevent build-up of static charge.

## For Additional Information about ESD

For more information about preventing ESD damage, contact the Electrical Over Stress/Electrostatic Discharge (EOS/ESD) Association, Inc. The ESD standards developed by this agency are sanctioned by the American National Standards Institute (ANSI).

## Upgrade Contents

Table 1 Upgrade Contents

Part Number	Description	Quantity
0515-0372	Screw-Machine W/Crest-Cup-Con-Washer Pan-HD Torx-T10 M3X0.5 8mm-LG	6
0515-1946	Screw-Machine w/Patch lock 90-DEG-flat-HD Torx-T10 M3X0.5 6mm-LG	18
0515-2151	Screw-Machine 90-DEG-FLT-HD TORX-T6 M2X0.4 4mm-LG	1
0515-2332	Screw-Machine W/PATCH-LK Pan-HD Torx-T10 M3X0.5 6mm-LG	4
0535-0031	Nut-HEX W/Lock-Washer M3X0.5 2.4mm-THK 5.5mm-A/F	2
1005-1388	Fiber Optic Adapter MPO-Shutter Female-Female flange-mount	1
1400-0053	Clamp-Cable Screw-mount	2
9030-0000	License Entitlement Certificate	1
M8121-60004	Connector-Fiber Optic Multimode MPO-Loopback	1
M8121-61614	Cable AY, Patch cord, ODI, F-F, 24 fiber, Type C, 3 M lg	1
M9484-80052	Label, FDA Laser	1
N9041-00043	Rear Panel	1
N9041-00052	Nut Plate, ODI	1
N9041-00053	Mount Plate, ODI	1
N9041-00055	Power Supply Adaptor Plate	1
N9041-20154	Heatsink, FireFly	1
N9041-20181	Insertion Tool, FireFly	1
N9041-61063	Cable Assembly, Optical Firefly TX/RX	1
N9042-80007	Label, KCC, 1220705 – Configuration A and B	1
N9042-80008	Label, KCC, 1222838 – Configuration C	1
M9484-80053	Label, FDA certification	1

This upgrade kits includes enough parts so that all versions of the N9042B instrument can be successfully upgraded with the IQ streaming option. Because of that, there may be some parts that will not be needed. The main differentiator for this is the presence of option G2H in the instrument. Instruments with option G2H are the latest version of hardware and will not require parts such as the new rear panel and some of the other small metal parts. The upgrade instructions will call out option G2H instruments when a decision on what parts to install needs to be made.

## Option ST1 and ST2 – IQ Streaming

### Tools Required

- Torx Driver T-10
- Torx Driver T-20
- Multi-Bit Torque Driver
- 5/8" Nut Driver
- 5/16" Wrench

### Initial Instrument Functionality Check

Power on the instrument and allow it to complete its boot up process. Verify that there are no instrument messages that would indicate that there is an issue with either the instrument hardware or software. If there are any issues, investigate and fix the problem before continuing with this upgrade.

### Instrument Software Revision Check

While the instrument is still powered on check to see what version of the instrument software is installed. To do so press **System, Show System** and look on the System Information screen for the **Instrument S/W Revision**. Record the software revision below.

**Instrument S/W Revision Installed:** \_\_\_\_\_

## Instrument Configuration Determination

The following instrument condition and configuration checks need to be performed before any work on upgrading the instrument is done. This information will assist in knowing what needs to be done to the instrument and what parts will be needed.

### Option G2H Check

While the instrument is still powered on check to see if the instrument has option G2H installed. To do so press **System, Show System** and look on the System Information screen for option **G2H**. Note whether option G2H is installed or not below.

**Option G2H Installed:** \_\_\_\_\_ Yes \_\_\_\_\_ No

### Option R40 Check

While the instrument is still powered on check to see if the instrument has option R40 installed. To do so press **System, Show System** and look on the System Information screen for option **R40**. Note whether option R40 is installed or not below.

**Option R40 Installed:** \_\_\_\_\_ Yes \_\_\_\_\_ No

### Installed Power Supply Check

Looking at the writing on the rear panel of the instrument for the power supply maximum power rating. It will either be 850 W Max or 900 W Max. Enter the value found below.

**Maximum Power Rating:** \_\_\_\_\_ Watts Max

### Determine Instrument Configuration

If the Maximum Power Rating is **850 watts**, the instrument has **Configuration A**.

If the Maximum Power Rating is **900 watts** and the instrument **does not have Option G2H**, the instrument has **Configuration B**.

If the Maximum Power Rating is **900 watts** and the instrument **has Option G2H**, the instrument has **Configuration C**.

The instrument configuration determined above will be used when it comes to reinstalling the instrument rear panel and the associated the rear panel ODI connector.

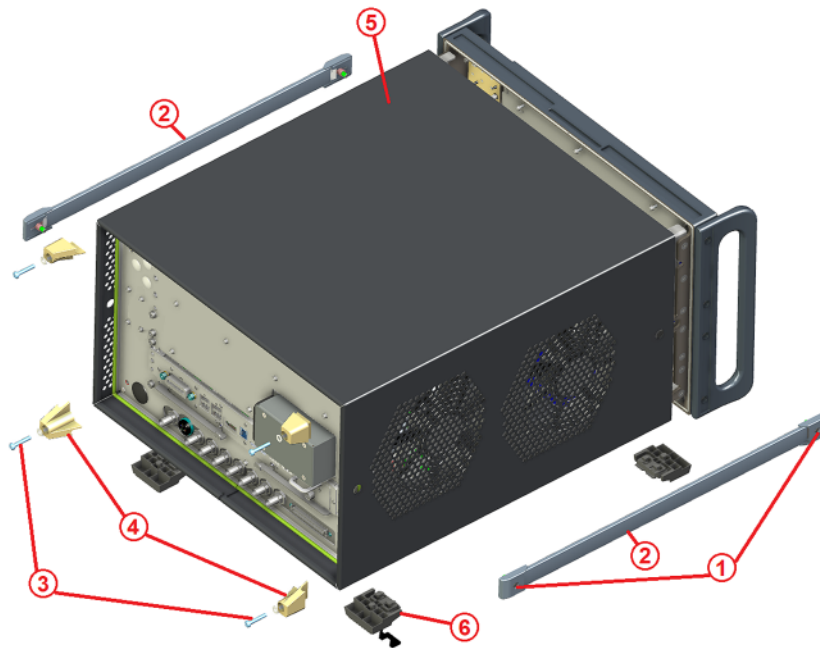
## Upgrade Instructions

### Hardware Disassembly

#### Dress Cover Removal

1. Turn the instrument off and disconnect the power cord.
2. Referring to **Figure 2**, remove the two screws (1) that attach the strap handle (2) from both sides and remove the strap handles.

**Figure 2** Dress Cover Removal

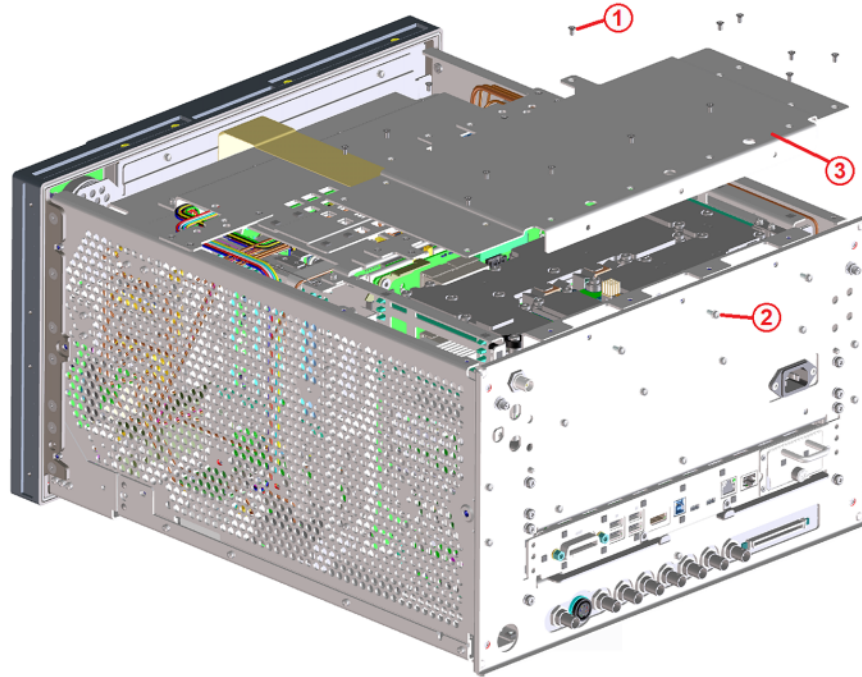


3. Remove the four rear feet (4) by removing the four screws (3) and washers that attach them.
4. Remove the four bottom feet (6) by first removing the locking keys and then lifting the tabs and sliding the foot toward the tabs.
5. Carefully slide the dress cover (5) off the instrument.

### Top Brace Removal

1. Referring to **Figure 3**, remove the fourteen flathead screws (1) and three panhead screw (2) attaching the top brace (3) to the instrument and set it aside. The fourteen flathead screws can be discarded, and they will be replaced with new ones.

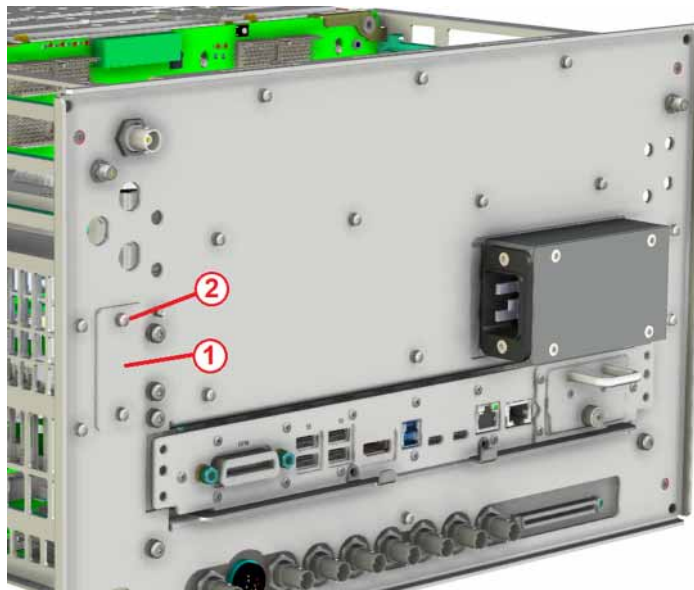
**Figure 3** Remove Top Brace



### Blank Plate Removal

1. Referring to **Figure 4**, if the instrument has a blank plate (1), remove the two panhead screws (2) securing it and discard the plate.

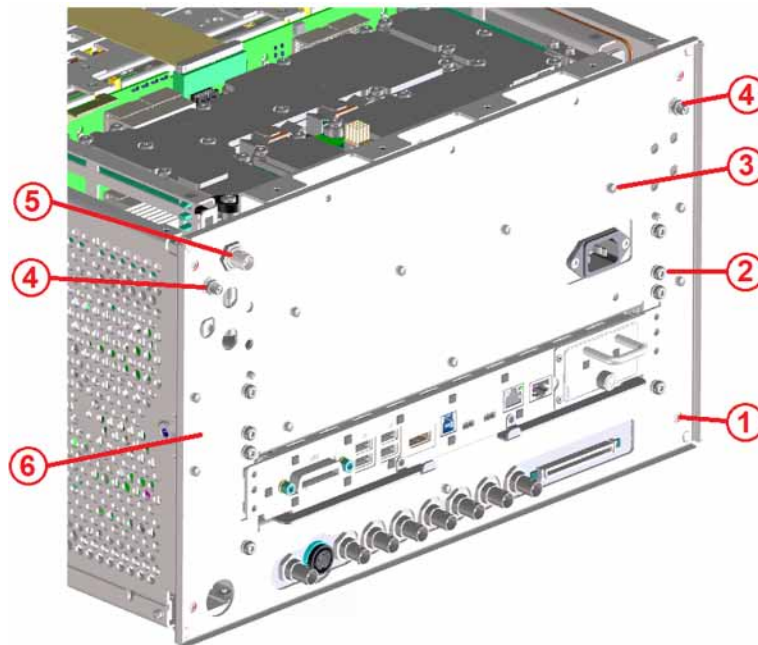
**Figure 4** Remove Blank Plate



### Rear Panel Removal

1. Referring to **Figure 5**, remove the four T-10 flathead screws (1) at the corners, the eight T-20 panhead screws (2), and the twelve T-10 panhead screws (3) that attach the rear panel to the instruments.

**Figure 5** Rear Panel Removal



2. Remove the nuts and lock washers from the two SMA connectors (4), and the nut and lock washer from the BNC connector (5).
3. Carefully remove the rear panel (6) from the instrument.

### A22 Ultra-Wideband Analog IF ODI Cable Disconnect – Option R40

1. Referring to **Figure 6**, if the instrument has the option R40 A22 Ultra-Wideband Analog IF assembly (1), carefully disconnect the Optical Data Interface (ODI) cable coming from the A22 assembly (2) from the center connector block (4) by sliding the blue locking tab away from the connection.

**Figure 6** A22 Ultra-Wideband Analog IF ODI Cable Disconnect – Option R40



**CAUTION**

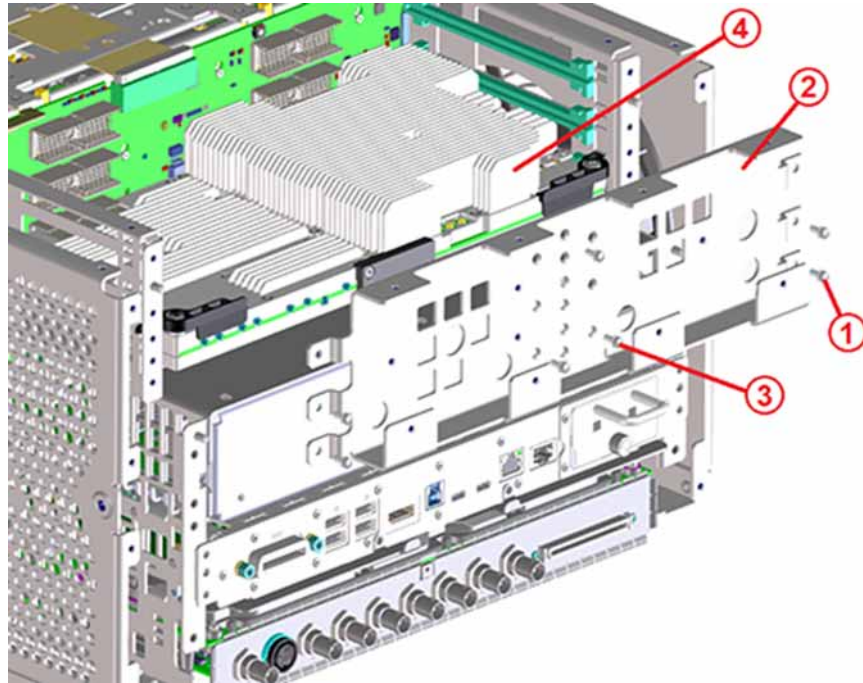
Great care needs to be taken when installing, removing, and handling any of the Optical Data Interface cables as they can be easily damaged if they are bent too tight or pinched.

2. Carefully disconnect the Optical Data Interface (ODI) cable coming from the A21 assembly (3) from the center connector block (4) by sliding the blue locking tab away from the connection.
3. Remove the two panhead screws (5) along with the two cable clamps.

### Chassis Rear Brace Removal

1. Referring to **Figure 7**, remove the 4 panhead screws (1) attaching the chassis rear brace (2) to the instrument chassis sides.

**Figure 7** Chassis Rear Brace Removal



2. Remove the two flathead screws (3) attaching the chassis rear brace (2) to the A21 Wideband Digital IF (4).

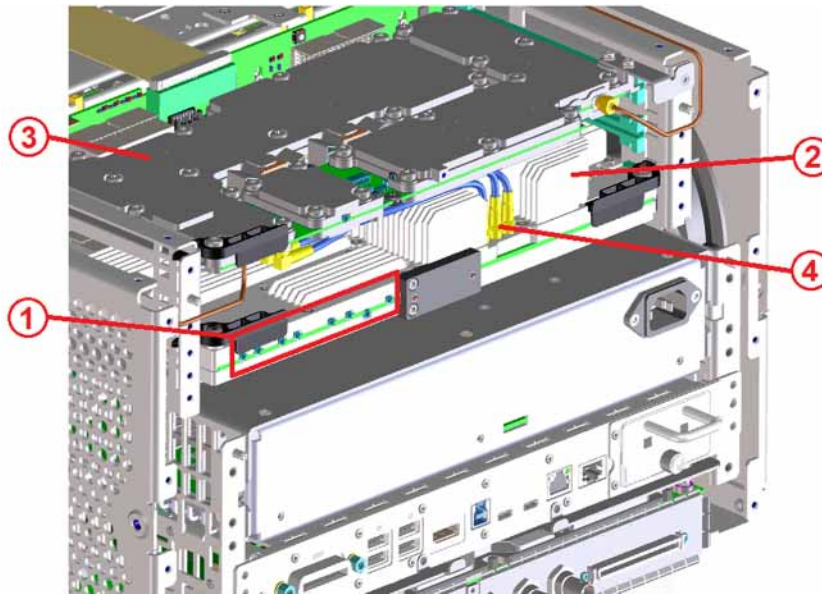
**NOTE**

If the instrument has the option R40 A22 Ultra-Wideband Analog IF there will be a third flathead screw (3) to remove attaching the chassis rear brace (2) to it.

### A21 Wideband Digital IF Removal

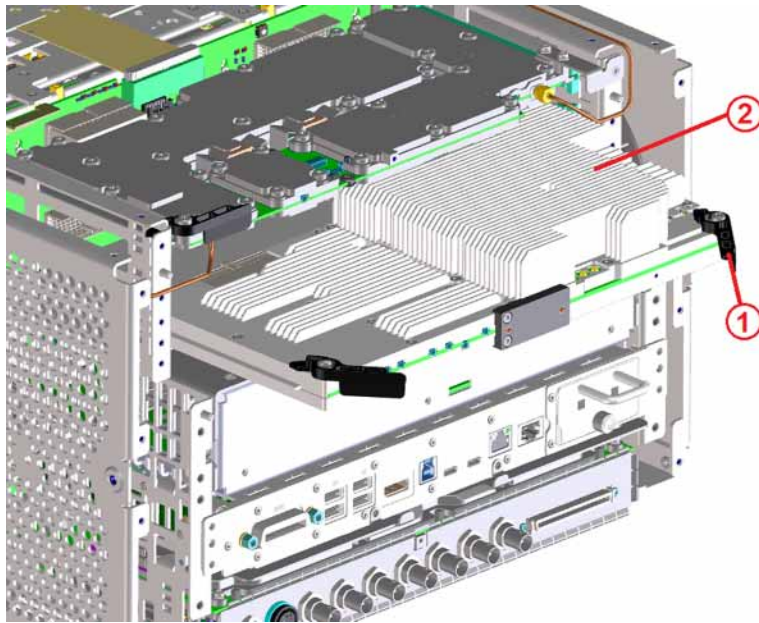
1. Referring to **Figure 8**, remove all the flexible RF cables in the marked area (1) from the A21 Wideband Digital IF (2).

**Figure 8** A21 Wideband Digital IF Connections Removal



2. Referring to **Figure 8**, if the instrument has the option R40 A22 Ultra-Wideband Analog IF (3) installed, carefully remove the three twinax cables (4) from the A21 Wideband Digital IF (2) by turning the hex base of the cable connectors a quarter of a turn counterclockwise, then carefully pulling the cables straight up, leaving them connected on the A22 Ultra-Wideband Analog IF end.
3. Referring to **Figure 9**, use the two board extractors (1) to carefully remove the A21 Wideband Digital IF from the instrument.

**Figure 9** A21 Wideband Digital IF Extraction



## ODI Cable Installation

The parts from this upgrade kit that will be needed for this section are listed in [Table 2](#).

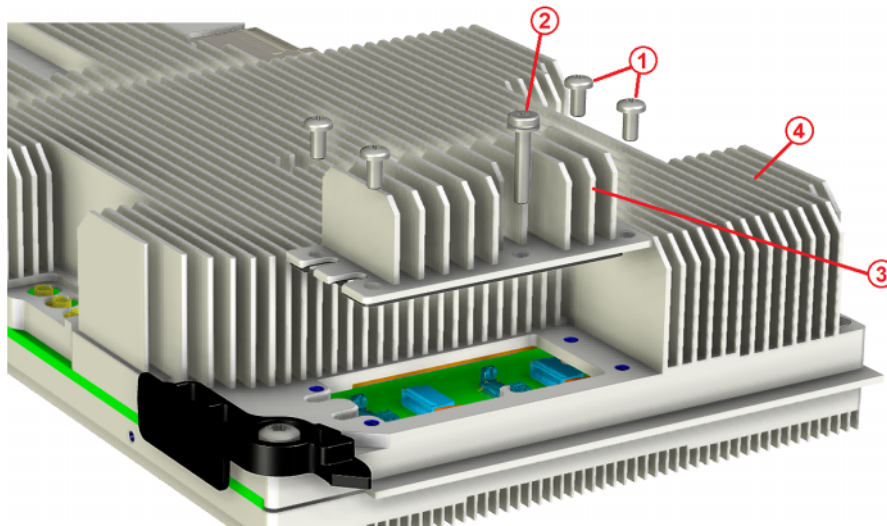
**Table 2** Parts Required

Part Number	Description	Quantity
N9041-61063	Cable Assembly, Optical Firefly TX/RX	1
N9041-20154	Heatsink, FireFly	1
0515-2332	Patch Lock Panhead Screw -M3.0	4
0515-0372	Panhead Screw – M3.0	2
1400-0053	Clamp-Cable Screw-mount	2

## ODI Heatsink Removal

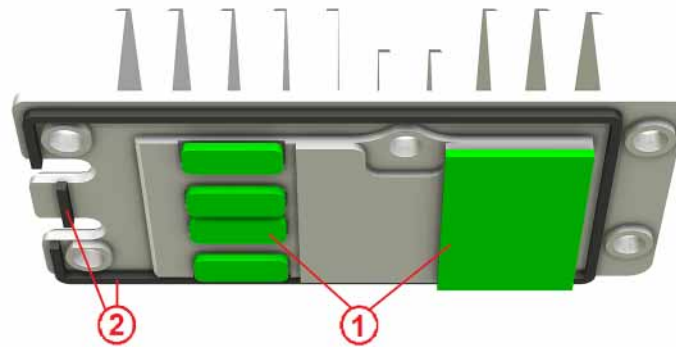
1. Referring to [Figure 10](#), remove the four short panhead screws (1) and the one long panhead screw (2) attaching the ODI heatsink (3) to the A21 Wideband Digital IF (4).

**Figure 10** ODI Heatsink Removal



2. Remove the ODI heatsink (3) from the A21 Wideband Digital IF (4), making sure that all the thermal pads (1) and gasketing (2) come with it, as seen in [Figure 11](#). Discard the heatsink, the gasketing, and the thermal pads.

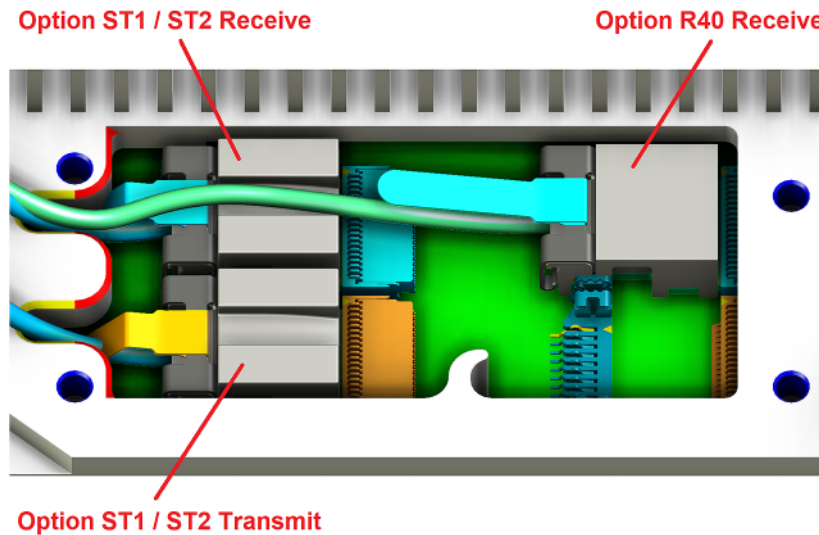
**Figure 11** ODI Heatsink Thermal Pads and Gasketing



**ODI Cable Installation**

The ODI cable provided in this kit has two connectors that need to be installed on the A21 Wideband Digital IF assembly. One is blue and the other is orange. The blue connector is the receiver end, and the orange is the transmitter, so they need to be installed in the correct location on the A21 assembly, as seen in **Figure 12**. Also, the option ST1/2 cable connectors must go into the connectors on the left as seen in **Figure 12**.

**Figure 12** ODI Cable Connector Locations



There is a tool included in this kit that needs to be used to install these connectors, as seen in **Figure 13**. The following procedure will describe and illustrate how this tool is used.

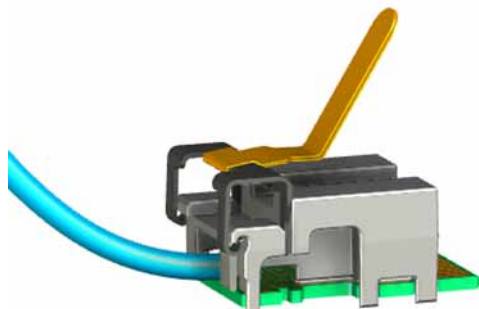
**Figure 13** ODI Connector Tool



## Option ST1 and ST2 – IQ Streaming

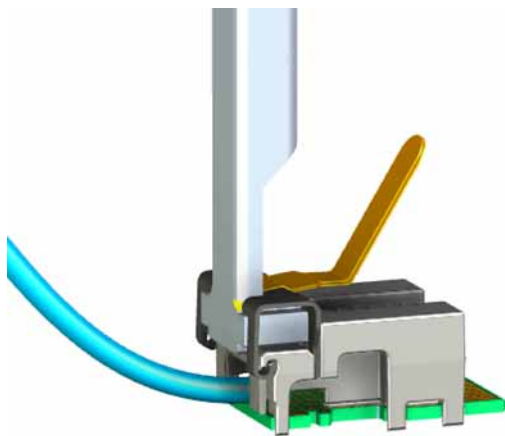
1. Use the pull tab on the orange ODI cable connector to lift the locking tab of the connector up, as seen in [Figure 14](#).

**Figure 14** ODI Connector Unlocked



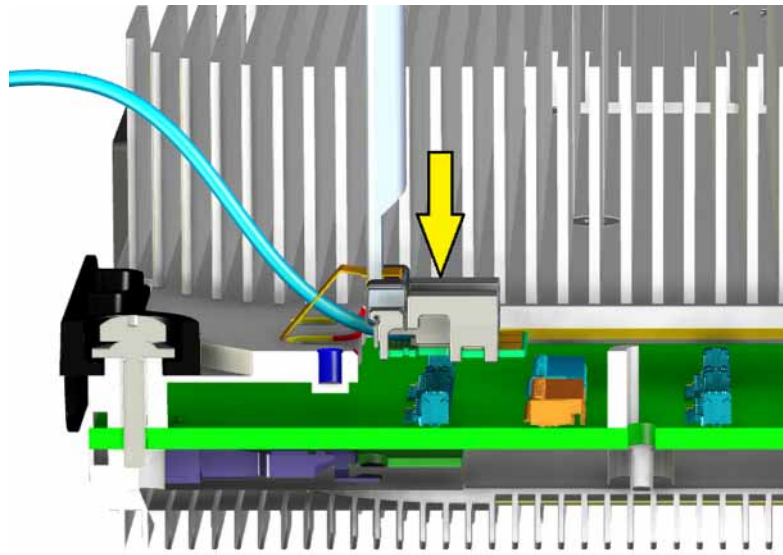
2. Insert the connector tool into the connector lock, as seen in [Figure 15](#).

**Figure 15** ODI Tool Inserted into Connector Lock

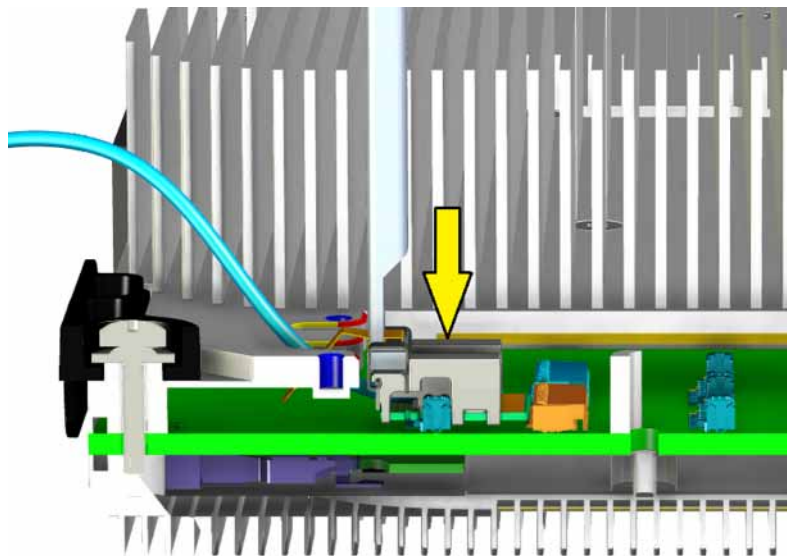


3. Use the connector tool to lower the cable connector over the orange connector on the A21 Wideband Digital IF, as seen in [Figure 16](#) and [Figure 17](#).

**Figure 16** Lower Cable Connector into Place

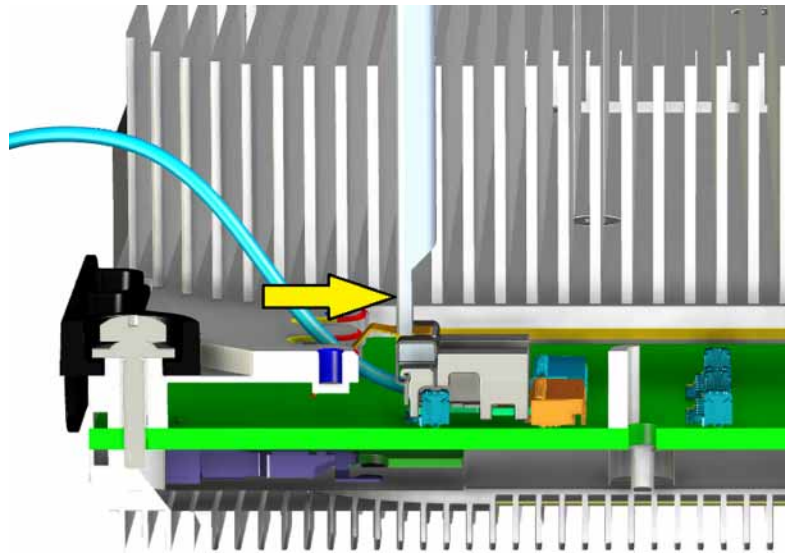


**Figure 17** Cable Connector Lowered onto Board



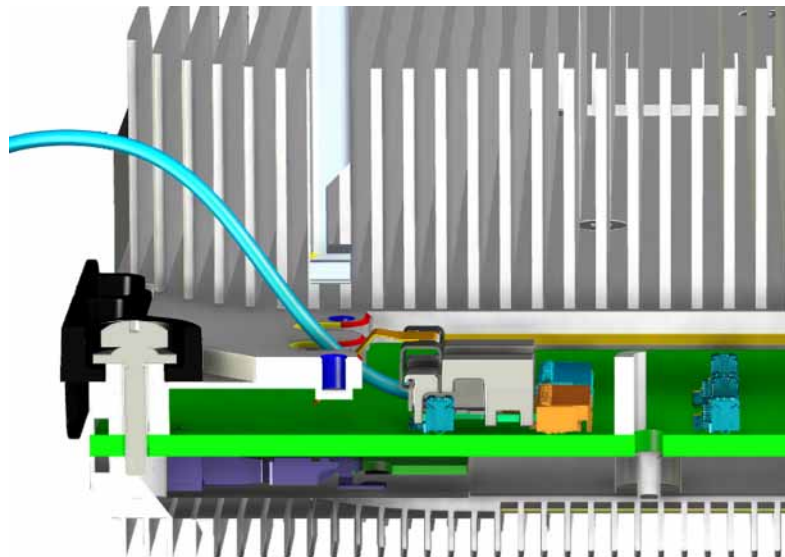
4. Use the tool to slide the connector forward to engage the connector, as seen in [Figure 18](#).

**Figure 18** Cable Connector Slide into Place

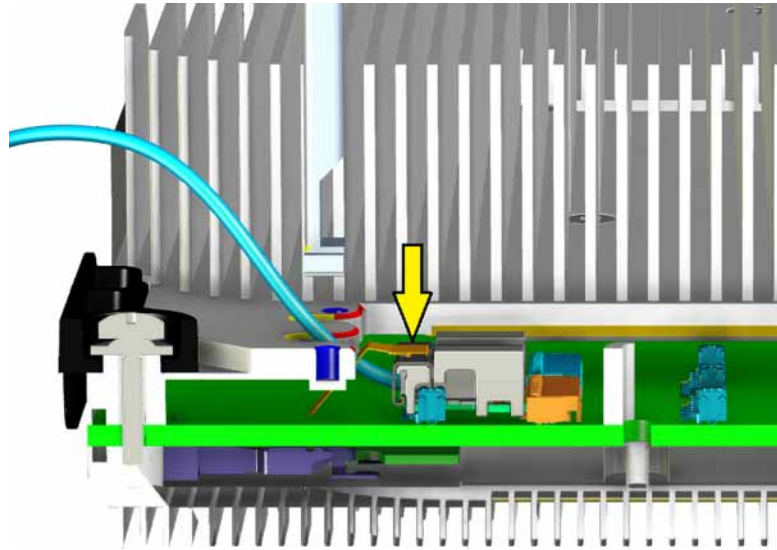


5. Remove the connector tool from the ODI cable connector, as seen in [Figure 19](#).

**Figure 19** ODI Tool Removed



6. Press the cable connector lock down to lock it into place, as seen in [Figure 20](#).

**Figure 20** Cable Connector Locked into Place

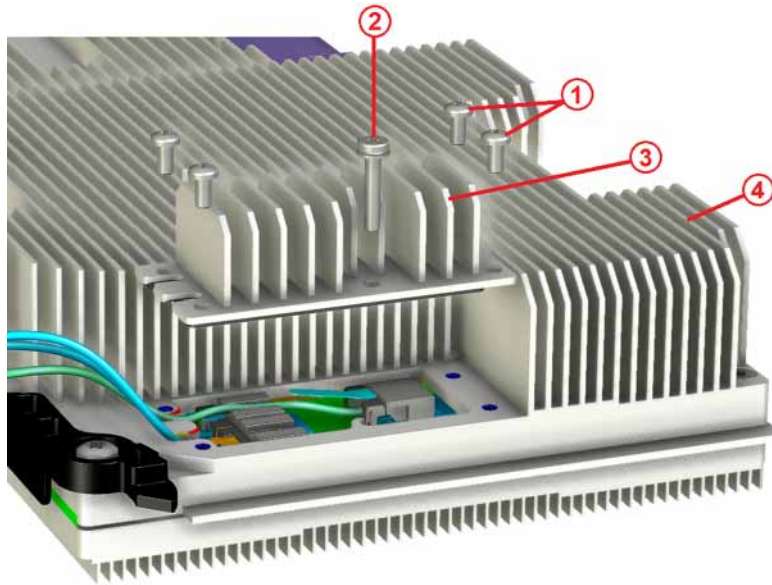
7. Use the ODI connector tool to install the blue cable connector into the connector on the A21 Wideband Digital IF next to the orange cable one that was just installed, as seen in [Figure 12](#).
8. Properly route all the ODI cables so that they do not get pinched when the new heatsink is put into place, as seen in [Figure 12](#).

**NOTE**

If the instrument has the option R40 A22 Ultra-Wideband Digital IF, be sure to route the ODI cable for it through the slot in the blue cable connector so that it does not get pinched when the new heatsink is put into place, as seen in [Figure 12](#).

9. Referring to [Figure 21](#), install the new ODI heatsink (3) with four short new flathead screws (1) and the one original long flathead screw (2) onto the A21 Wideband Digital IF assembly (4). Torque all the screws to 9 in-lbs.

**Figure 21** Install New ODI Heatsink



**NOTE**

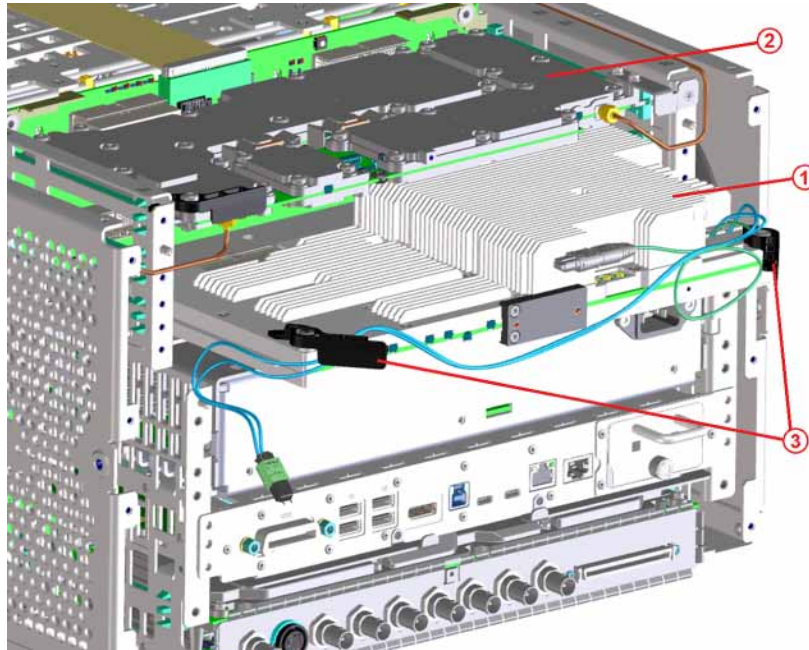
Be sure that all the thermal pads and gasketing are properly in place on the underside of the heatsink, as seen in [Figure 11](#), before placing the new heat sink in position.

---

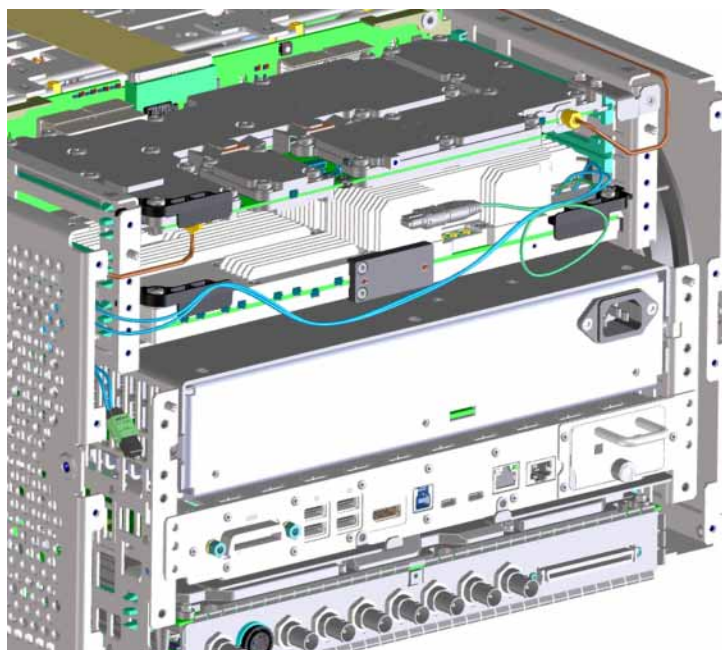
### Reinstall A21 Wideband Digital IF

1. Referring to **Figure 22**, reinstall the A21 Wideband Digital IF (1), carefully moving any cables out of the way, especially if the instrument has the option R40 A22 Ultra-Wideband Analog IF (2). Use the card extractors (3) to lock the assembly into place, as seen in **Figure 23**.

**Figure 22** Carefully Reinstall A21 Wideband Digital IF



**Figure 23** A21 Wideband Digital IF Reinstalled

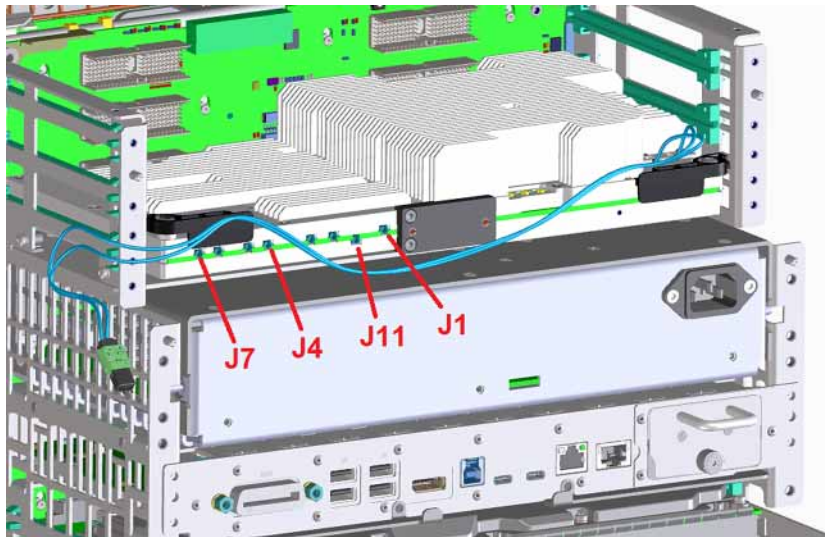


Option ST1 and ST2 – IQ Streaming

### Reinstall A21 Cables – Without Option R40

1. Referring to **Figure 24**, reinstall the four coax cables to the A21 Wideband Digital IF, as listed in **Table 3**.

**Figure 24** A21 Wideband Digital IF Connections - Without Option R40



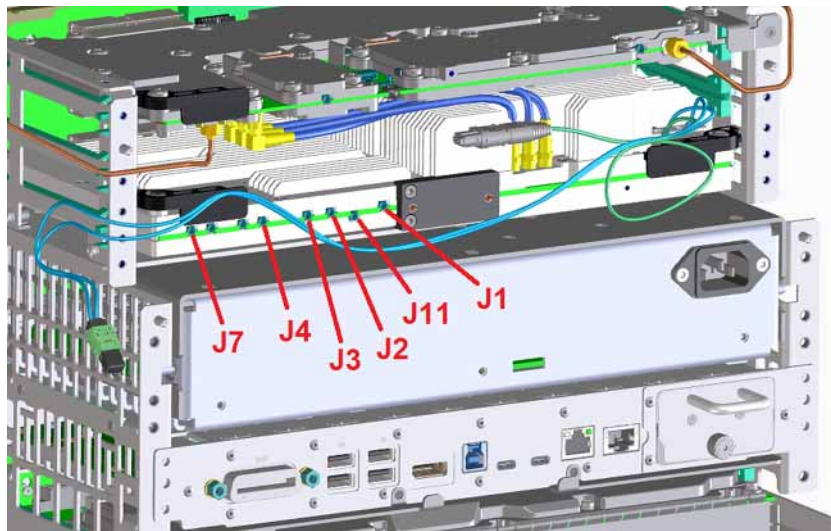
**Table 3** A21 Wideband Digital IF Connections - Without Option R40

A21 Port	To/From	Cable
J1	From A16 Reference J718	W109
J4	From A23 IF Mux J41	W116
J7	From A23 IF Mux J40	W115
J11	From Rear Panel Trigger 3 In	W111

## Reinstall A21 Cables – With Option R40

1. Referring to **Figure 25**, reinstall the six coax cables to the A21 Wideband Digital IF, as listed in **Table 4**.

**Figure 25** A21 Wideband Digital IF Connections - With Option R40

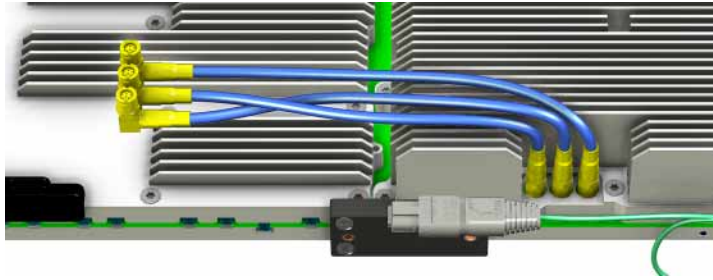


**Table 4** A21 Wideband Digital IF Connections - With Option R40

A21 Port	To/From	Cable
J1	From A16 Reference J718	W109
J2	From A22 Ultra-Wideband J14	W112
J3	To A22 Ultra-Wideband J15	W113
J4	From A23 IF Mux J41	W116
J7	From A23 IF Mux J40	W115
J11	From Rear Panel Trigger 3 In	W111

2. Referring to **Figure 26**, reconnect to three twinax cables as shown.

**Figure 26** Twinax Cable Connections - Option R40

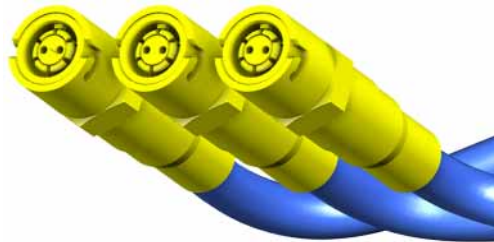


**NOTE**

The twinax cables have a tab that inserts into the locating slot on the board connectors, as seen in [Figure 27](#). Once the tab is inserted into the locating slot and the two center conductors are engaged, a spring loaded locking mechanism on the cable connector is used to engage with the two board connector tabs and twist to lock it in place. It may be beneficial to slide the A21 Wideband Digital IF out an inch or so for better access to these connections.

---

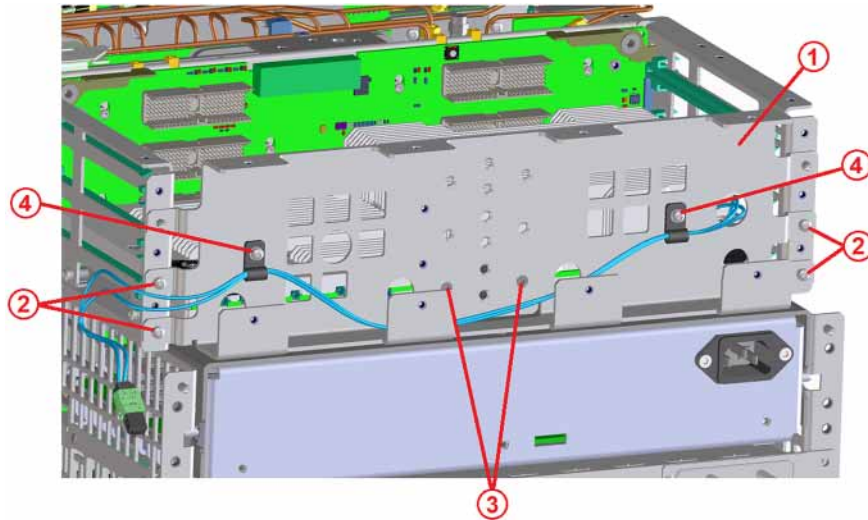
**Figure 27** Twinax Cable Connectors - Option R40



### Reinstall Chassis Rear Brace – Without Option R40

1. Referring to **Figure 28**, reinstall the chassis rear brace (1), carefully routing the ODI cables through the round hole provided in the rear brace.

**Figure 28** Reinstall Chassis Rear Brace - Without Option R40



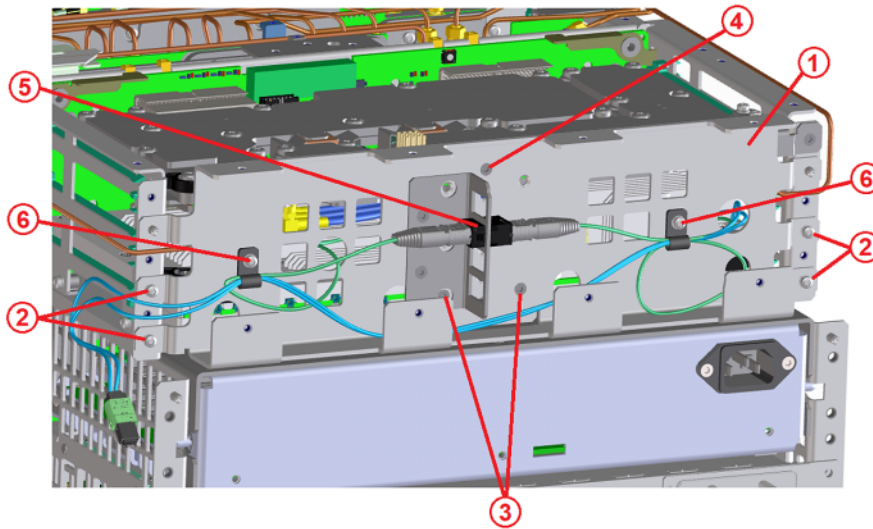
2. Secure the chassis rear brace to the instrument with the four M3.0 panhead screws (2) and the two new M3.0 flathead screws (3). Torque all screws to 9 in-lbs.
3. Secure the ODI cables to the chassis rear brace using the two cable clamps and two new M3.0 panhead screws (4) provided in this kit, as seen in **Figure 28**. Torque the screws to 9 in-lbs.

### Reinstall Chassis Rear Brace – With Option R40

There are no new parts from this upgrade kit that will be needed in this section.

1. Referring to **Figure 29**, reinstall the chassis rear brace (1), carefully routing all the ODI cables through the two round holes provided in the rear brace.

**Figure 29** Reinstall Chassis Rear Brace - With Option R40



2. Secure the chassis rear brace to the instrument with the four M3.0 panhead screws (2), the two new M3.0 flathead screws (3), and the one new M3.0 flathead (4). Torque all screws to 9 in-lbs.
3. Connect the two option R40 ODI cables to the adapter block (5). The cables are keyed and can only be inserted one way. Be sure to insert them all the way, until a click is heard.
4. Secure all the ODI cables to the chassis rear brace using the two cable clamps and two M3.0 panhead screws (4), as seen in **Figure 29**. Torque the screws to 9 in-lbs.

## Rear Panel Configuration and Installation

This is the part of the upgrade process that will be different depending on the instrument Configuration that was determined in the **Instrument Configuration Determination** section earlier in this installation note. Use that determination to proceed with the correct rear panel configuration section.

### NOTE

The instrument's original rear panel will be reused for all but configuration A, as we do not want to have to move the instrument serial number label any more than needed.

## Rear Panel Configuration A

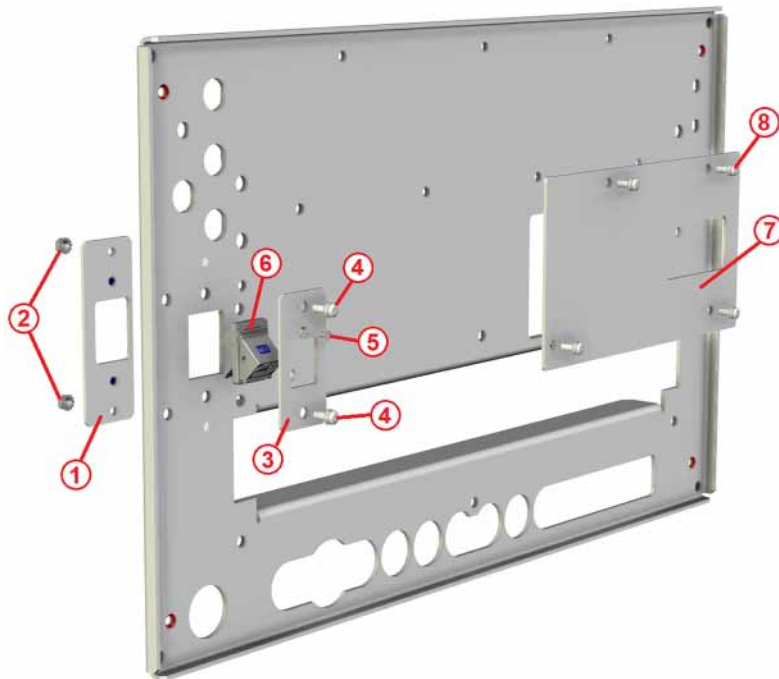
The parts from this upgrade kit that will be needed for this section are listed in **Table 5**.

**Table 5**                      **Parts Required**

<b>Part Number</b>	<b>Description</b>	<b>Quantity</b>
N9041-00043	Rear Panel	1
N9041-00053	Mount Plate	1
N9041-00052	Nut Plate	1
1005-1388	Fiber Optic Flange Mount Adapter	1
N9041-00055	Power Supply Adapter Plate	1
0535-0031	Hex Nut	2
0515-2151	Flathead Screw – M2.0	1
0515-1946	Patch Lock Flathead Screw – M3.0	4
0515-0372	Panhead Screw – M3.0	6

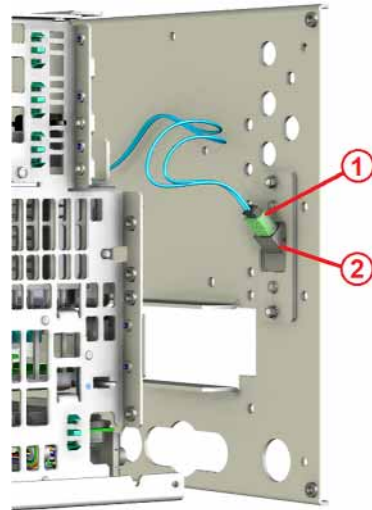
1. Referring to **Figure 30**, attach the nut plate (1) to the new rear panel using the two hex nuts (2). Torque to 9 in-lbs.

**Figure 30** Rear Panel Assembly - Configuration A



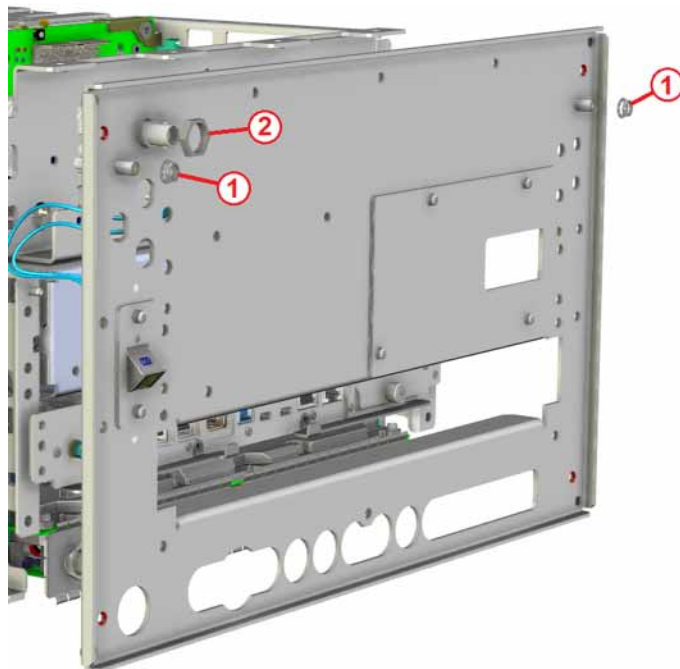
2. Attach the mount plate (3) to the new rear panel using the two M3.0 panhead screws (4). Torque to 9 in-lbs.
3. Attach the fiber optic flange mount adapter (6) to the mount plate (3) using the M2.0 flathead screw (5). Torque to 6 in-lbs.
4. Attach the power supply adapter plate (7) to the rear panel with the four M3.0 panhead screws (8). Torque to 9 in-lbs.
5. Referring to [Figure 31](#), insert the ODI cable (1) into the rear panel fiber optic flange mount adapter (2). The cable is keyed and can only be inserted one way. Be sure to insert it all the way, until a click is heard.

**Figure 31** Insert ODI Cable



6. Referring to **Figure 32**, insert the two SMA cables through the rear panel TRIGGER 3 IN and AUX IF OUT ports and secure them with the original lock washers and nuts (1). Torque them to 10 in-lbs.

**Figure 32** Rear Panel Cables Installation - Configuration A



7. Insert the BNC cable through the rear panel EXT REF IN port and secure with the lock washer and nut (2). Torque to 21 in-lbs.

8. Referring to **Figure 33**, install the rear panel onto the instrument and secure it with the eight M4.0 panhead screws (1), the eight M3.0 panhead screws (2), and the four new M3.0 flathead screws (3). Torque the M3.0 screws to 9 in-lbs. and the M4.0 screws to 21 in-lbs.

**Figure 33** Reinstall Rear Panel - Configuration A



## Rear Panel Configuration B

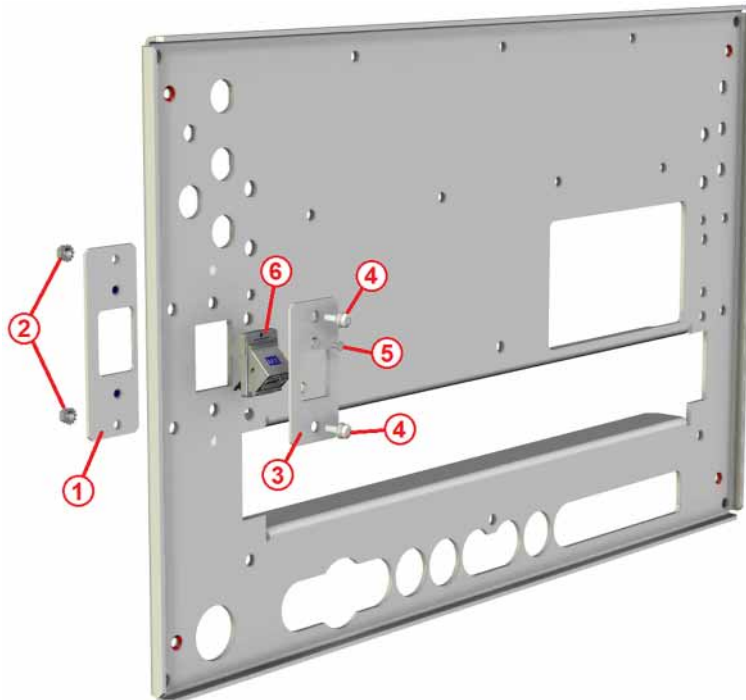
The parts from this upgrade kit that will be needed for this section are listed in [Table 6](#), along with the original rear panel from the instrument.

**Table 6** Parts Required

Part Number	Description	Quantity
N9041-00053	Mount Plate	1
N9041-00052	Nut Plate	1
1005-1388	Fiber Optic Flange Mount Adapter	1
0535-0031	Hex Nut	2
0515-2151	Flathead Screw – M2.0	1
0515-1946	Patch Lock Flathead Screw – M3.0	4

1. Referring to [Figure 34](#), attach the nut plate (1) to the new rear panel using the two hex nuts (2). Torque to 9 in-lbs.

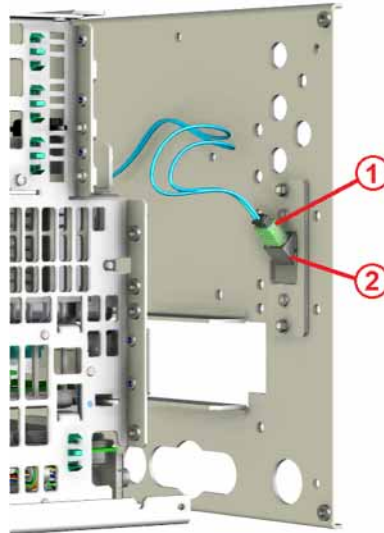
**Figure 34** Rear Panel Assembly - Configuration B



2. Attach the mount plate (3) to the new rear panel using the two panhead screws (4). Torque to 9 in-lbs.
3. Attach the fiber optic flange mount adapter (6) to the mount plate (3) using the flathead screw (5). Torque to 6 in-lbs.

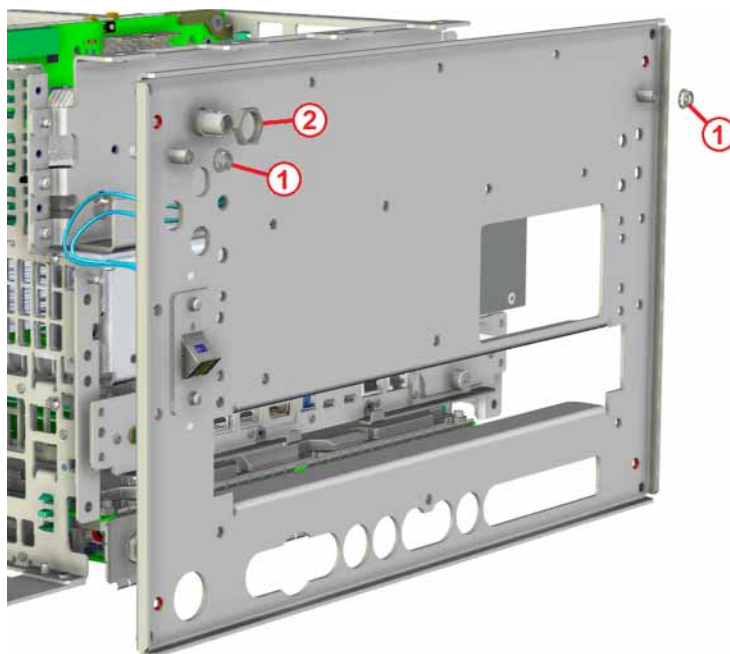
4. Referring to **Figure 35**, insert the ODI cable (1) into the rear panel fiber optic flange mount adapter (2). The cable is keyed and can only be inserted one way. Be sure to insert it all the way, until a click is heard.

**Figure 35** Insert ODI Cable



5. Referring to **Figure 36**, insert the two SMA cables through the rear panel TRIGGER 3 IN and AUX IF OUT ports and secure them with the original lock washers and nuts (1). Torque them to 10 in-lbs.

**Figure 36** Rear Panel Cables Installation - Configuration B



6. Insert the BNC cable through the rear panel EXT REF IN port and secure with the lock washer and nut (2). Torque to 21 in-lbs.
7. Referring to **Figure 37**, install the rear panel onto the instrument and secure it with the eight M4.0 panhead screws (1), the eleven M3.0 panhead screws (2), and the four new M3.0 flathead screws (3). Torque the M3.0 screws to 9 in-lbs. and the M4.0 screws to 21 in-lbs.

**Figure 37** Reinstall Rear Panel - Configuration B



### Rear Panel Configuration C

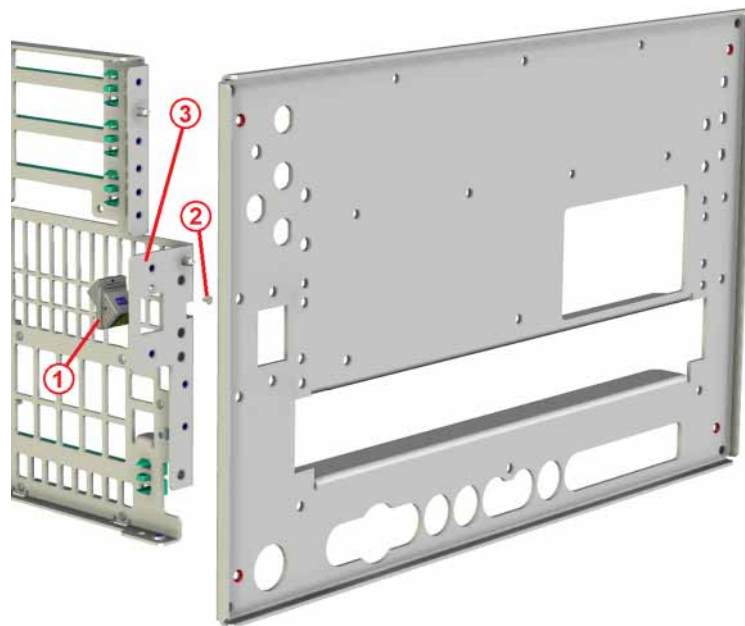
The parts from this upgrade kit that will be needed for this section are listed in [Table 7](#), along with the original rear panel from the instrument.

**Table 7** Parts Required

Part Number	Description	Quantity
1005-1388	Fiber Optic Flange Mount Adapter	1
0515-2151	Flathead Screw – M2.0	1
0515-1946	Patch Lock Flathead Screw – M3.0	4

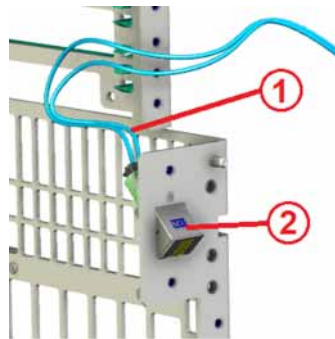
1. Referring to [Figure 38](#), attach the fiber optic flange mount adapter (1) to the existing instrument chassis right side inner panel (3) using the M2.0 flathead screw (2). Torque to 6 in-lbs.

**Figure 38** Rear Panel Assembly - Configuration C



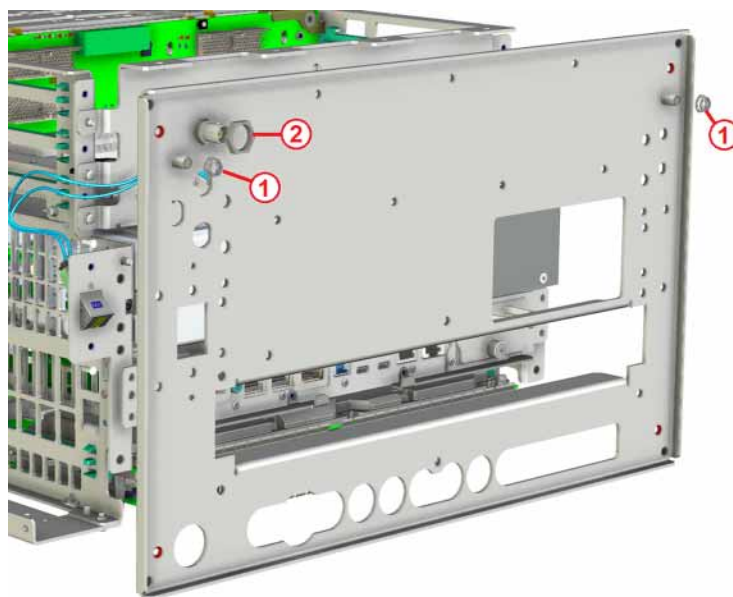
2. Carefully insert the ODI cable (1) into the fiber optic flange mount adapter (2), as seen in [Figure 39](#). The cable is keyed and can only be inserted one way. Be sure to insert it all the way, until a click is heard.

**Figure 39** ODI Cable Insertion - Configuration C



3. Referring to **Figure 40**, insert the two SMA cables through the instrument's original rear panel TRIGGER 3 IN and AUX IF OUT ports and secure them with the original lock washers and nuts (1). Torque them to 10 in-lbs.

**Figure 40** Rear Panel Cables Installation - Configuration C



4. Insert the BNC cable through the rear panel EXT REF IN port and secure with the lock washer and nut (2). Torque to 21 in-lbs.
5. Referring to **Figure 41**, install the rear panel onto the instrument and secure it with the eight M4.0 panhead screws (3), the thirteen M3.0 panhead screws (4), and the four new M3.0 flathead screws (5). Torque the M3.0 screws to 9 in-lbs. and the M4.0 screws to 21 in-lbs.

**Figure 41** Reinstall Rear Panel - Configuration C



## Instrument Button Up

The parts from this upgrade kit that will be needed for this section are listed in [Table 8](#).

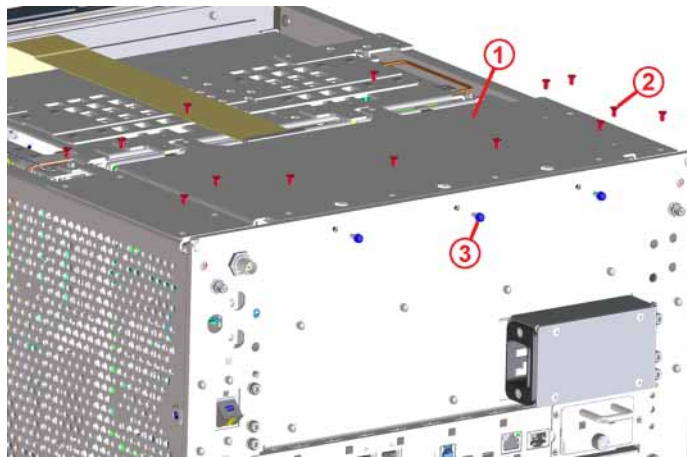
**Table 8**                      **Parts Required**

Part Number	Description	Quantity
0515-1946	Patch Lock Flathead Screw – M3.0	14

## Top Brace Installation

1. Referring to [Figure 42](#), replace the top brace (1) and secure it with the fourteen new M3.0 flathead screws (2) and the three M3.0 panhead screw (3). Torque all screws to 9 in-lbs.

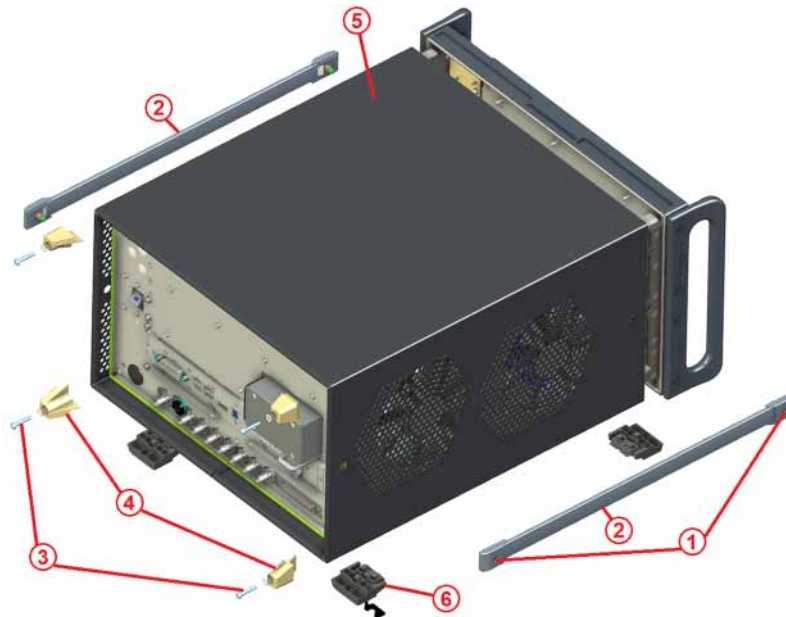
**Figure 42**                      **Top Brace Installation**



### Dress Cover Installation

1. Referring to **Figure 43**, carefully slide the outer cover (5) onto the instrument.

**Figure 43** Dress Cover Installation



2. Attach the four rear feet (4) using the four panhead screws and washers (3). Torque the screws to 21 in-lbs.
3. Install the four bottom feet (6) along with the locking keys.
4. Install the strap handles (2) to both side of the instrument using the two screws (1) at either end of the handles. Torque the screws to 21 in-lbs.

## Rear Panel Labels

There are three rear panel labels that need to be verified at this point:

1. Serial Number Label
2. KCC Certification Label
3. FDA Laser Label

### NOTE

It is very important that all instructions in the section be closely followed, as legal and safety matters are involved.

### Serial Number Label

If the rear panel was changed during this upgrade, the serial number label will need to be carefully transferred from the original rear panel to the new one.

The serial number label needs to be attached in the area outlined in [Figure 44](#).

### KCC Certification Label

If the rear panel was changed during this upgrade, one of the two KCC certification label provided needs to be affixed to the new rear panel. The only instruments that should have the rear panel changed during this upgrade are those with configuration A. However, two labels have been provided to cover all three of the possible configurations just in case a replacement rear panel is needed for other reasons. Which label is required for each of the three different instrument configurations, as outlined in the [Instrument Configuration Determination](#) section above, can be seen in [Table 9](#).

Table 9 KCC Certification Label Selection

Configuration	Label Part Number	Label Description
A	N9042-80007	Label, KCC, 1220705
B	N9042-80007	Label, KCC, 1220705
C	N9042-80008	Label, KCC, 1222838

The KCC certification label needs to be attached in the area outlined in [Figure 44](#).

### FDA Laser Certification Label

Once upgraded, all instruments need to have one of the FDA Laser Certification labels attached to the rear panel. The label needed depends on the country of origin of the instrument, which is identified by the instrument serial prefix, as seen in [Table 10](#).

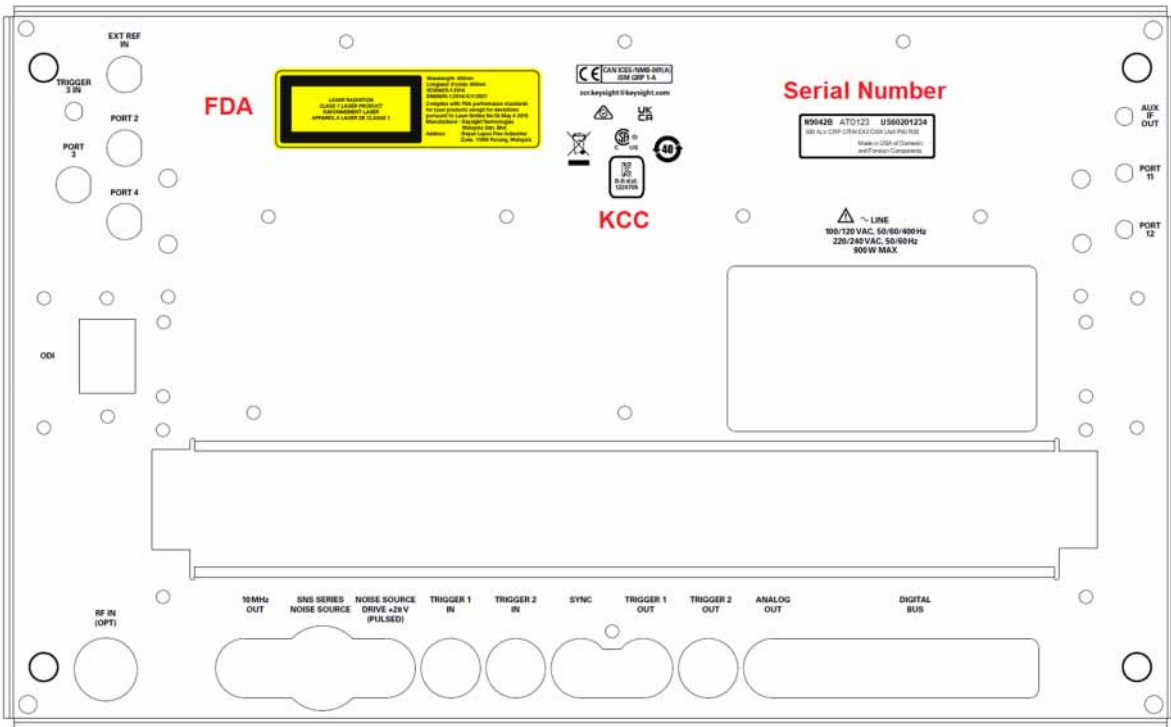
Table 10 FDA Laser Certification Label Selection

Serial Prefix	Label Part Number	Label Description
MY	M9484-80052	Label, FDA Laser
US	M9484-80053	Label, FDA certification

# Option ST1 and ST2 – IQ Streaming

The FDA laser certification label needs to be attached in the area outlined in **Figure 44**.

**Figure 44** Label Locations



## Instrument Software Installation

The instrument software is required to be version A.34.00 or newer for this option to be recognized. If the instrument being upgraded does not already have a version that meets this requirement, the instrument software will need to be installed at this time.

1. Download the latest instrument software version and instructions from:  
[https://www.keysight.com/find/n9042b\\_software](https://www.keysight.com/find/n9042b_software)
2. When the instrument software update has completed the instrument will be ready to proceed with the next step in this procedure.

## License Key Retrieval and Installation

1. Follow the instructions on the enclosed License Entitlement Certificate to redeem the new option license key for the instrument being upgraded.
2. Once the new license keys have been redeemed follow the installation instructions that come with the license file to install it into the instrument.
3. Once the license has been installed cycle the instrument power.
4. Verify that the license has been installed by pressing **System, Show System** and verify that the option is present in the listed options.

## Option ST1 and ST2 – IQ Streaming

### Extra Parts

There will be a number of extra parts in the kit that will not be needed for any given upgrade, depending on the configuration of the instrument, and these can be discarded. However, there is one part that needs to be returned to the owner of the instrument along with the instrument once the upgrade is completed. This part is:

**Part Number:** M8121-61614

**Description:** Cable AY, Patch cord, ODI, F-F, 24 fiber, Type C, 3 M lg

This patch cable is intended for use by the owner of the instrument to connect their streaming device to the newly installed ODI port.

The loopback dongle that is included in this kit (M8121-60004) is only intended to be used to verify that the installed option hardware is installed properly by the ODI Loopback Test. After the hardware has been verified the dongle can be discarded.

## Adjustments and Performance Verification

### **Manual Procedures Required**

ODI Loopback Test

### **Automated Utilities Required**

None

### **Automated Adjustments Required**

None

### **Automated Performance Testing Required**

Noise Density

Residual Response

Displayed Average Noise Level

IF Frequency Response

IF Amplitude Accuracy

For assistance, contact your nearest Keysight Technologies Sales and Service Office.  
To find your local office access the following URL:

<https://www.keysight.com/find/assist>

## ODI Loopback Test

Use the following procedure to run the loopback test to verify that the newly installed streaming option hardware is working properly.

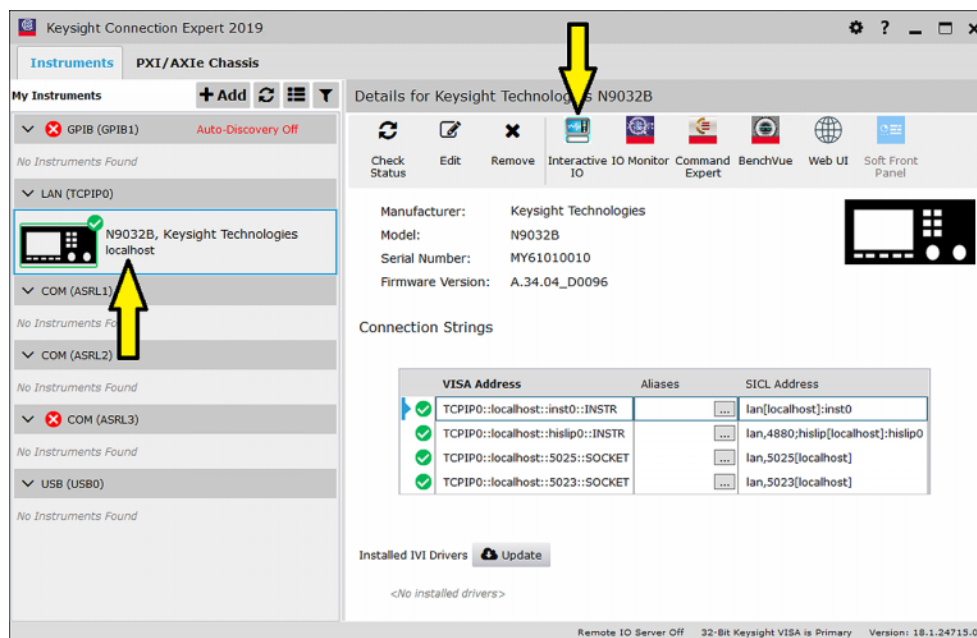
1. Connect a USB keyboard and mouse to the instrument.
2. Change the instrument mode and measurement to IQ Analyzer mode and the Streaming measurement by pressing **Mode/Meas, IQ Analyzer, Streaming, OK**.
3. Insert the Loopback Dongle that is included with this kit (M8121-60004) into the rear panel ODI port with the alignment tab pointing up, making sure that it positively snaps into place.

### NOTE

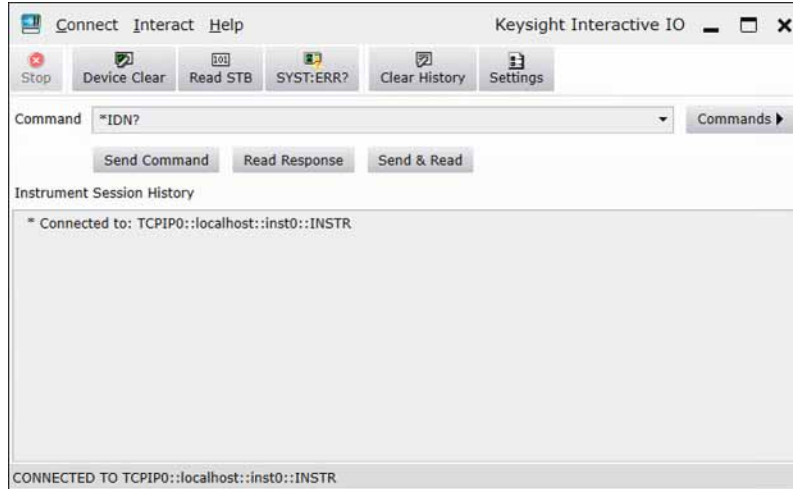
It is very important that the dongle is correctly inserted all the way into the rear panel ODI port. It must click into place such that it cannot be removed without sliding the spring loaded latch to release it.

4. Using the USB mouse, select **Start, Keysight Connection Expert**. You should then see the connection expert, as seen in [Figure 45](#).

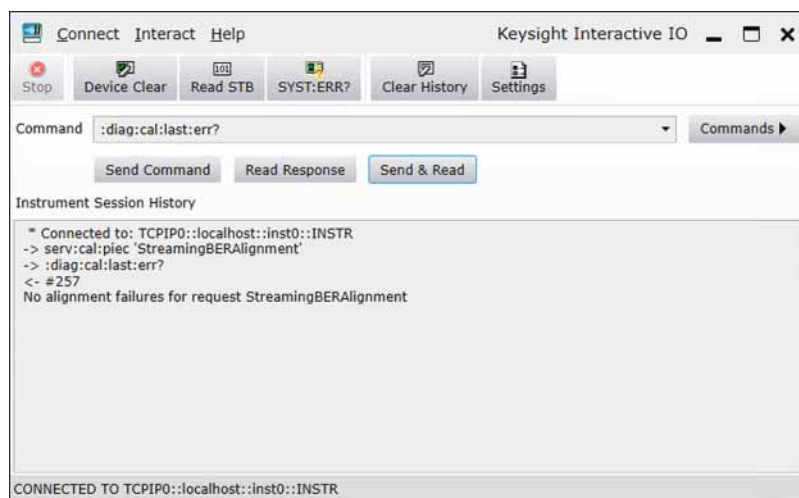
**Figure 45** Keysight Connection Expert



5. Select the instrument listed as **localhost**, then select **Interactive IO** for it. You will then see the Interactive IO window for the instrument, as seen in [Figure 46](#).

**Figure 46** Interactive IO

6. To run the test, type the following command into the **Command** field:  
:serv:cal:piec 'StreamingBERAlignment'
7. Press **Send Command**.
8. To verify that the test passed, type the following into the **Command** field:  
:diag:cal:last:err?
9. Press **Send & Read**.
10. As seen in [Figure 47](#), the response from the instrument should include:  
No alignment failures for request StreamingBERAlignment

**Figure 47** Loopback Test Results

If the test shows a failure, make sure that the loopback dongle is properly inserted into the rear panel ODI port.



This information is subject to change without notice.

© Keysight Technologies 2023-2024

Edition 1, December 2024

N9042-90011

[www.keysight.com](http://www.keysight.com)