X-Series Signal Analyzer

N9042B

Cooling Fan Upgrade

Option HW2

Notices

© Copyright 2023 Keysight Technologies, Inc.

The information contained in this document is subject to change without notice.

Keysight Technologies makes no warranty of any kind with regard to this material, including but not limited to, the implied warranties of merchantability and fitness for a particular purpose.

Keysight Technologies shall not be liable for errors contained herein or for incidental or consequential damages in connection with the furnishing, performance, or use of this material.

Manual Part Number

N9042-90013

Edition

Edition 1, January 2023

Supersedes: none

Printed in USA/Malaysia

Published by:

Keysight Technologies, Inc.
1400 Fountaingrove Parkway
Santa Rosa, CA 95403

Option HW2 – Cooling Fan Upgrade

Products Affected:	UXA N9042B
To Be Performed By:	(X) Keysight Service Center (X) Advanced User () User
Estimated Installation Time:	1.5 Hours
Estimated Adjustment Time:	0.0 Hours
Estimated Verification Time:	1.0 Hours

This document provides detailed instructions for the installation of the Cooling Fan upgrade for the N9042B UXA Signal Analyzer.

Please be sure to read this entire document before attempting to perform this upgrade. Then, be sure to perform the steps in this procedure in the order that they are listed so that the installation will complete properly, and the instrument will function as desired when completed.

Compatibility

This instrument option requires no specific instrument firmware version and is compatible with all N9042B instruments. However, all instruments with option G2H do not require this upgrade, they include it from the factory.

Instrument Calibration

The validity of any existing calibration that the instrument being upgraded may have will not be affected by the installation of this upgrade.

What You Will Find in this Document

What You Will Find in this Document

ESD Information.....	page 5
Upgrade Contents	page 7
Tools Required	page 7
Initial Instrument Functionality Check	page 7
Option G2H Check.....	page 7
Upgrade Instructions.....	page 8
Hardware Removal	page 8
Hardware Installation	page 13
Verify Operation	page 16
Instrument Button Up.....	page 17
Adjustments and Performance Verification	page 18
Manual Procedures Required	page 18
Automated Utilities Required	page 18
Automated Adjustments Required	page 18
Automated Performance Verification Testing Required	page 18

ESD Information

Protection from Electrostatic Discharge

Electrostatic discharge (ESD) can damage or destroy electronic components. All work on electronic assemblies should be performed at a static-safe workstation. **Figure 1** shows an example of a static-safe workstation using two types of ESD protection:

- Conductive table-mat and wrist-strap combination.
- Conductive floor-mat and heel-strap combination.

Both types, when used together, provide a significant level of ESD protection. Of the two, only the table-mat and wrist-strap combination provides adequate ESD protection when used alone. To ensure user safety, the static-safe accessories must provide at least 1 megohm of isolation from ground.

WARNING

These techniques for a static-safe workstation should not be used when working on circuitry with a voltage potential greater than 500 volts.

Figure 1 Example of a Static-Safe Workstation

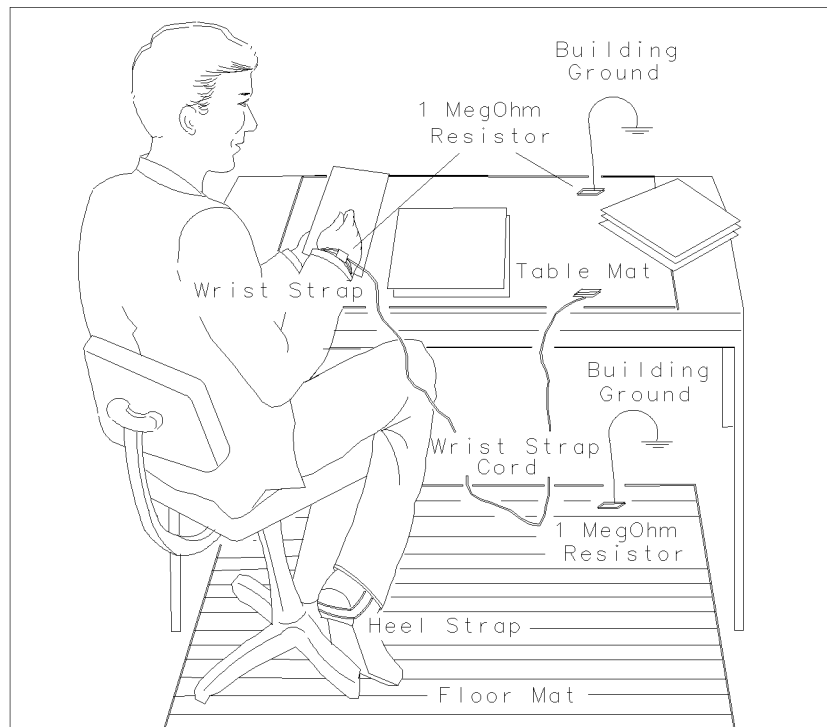

ESD Information

Handling of Electronic Components and ESD

The possibility of unseen damage caused by ESD is present whenever components are transported, stored, or used. The risk of ESD damage can be greatly reduced by paying close attention to how all components are handled.

- Perform work on all components at a static-safe workstation.
- Keep static-generating materials at least one meter away from all components.
- Store or transport components in static-shielding containers.

CAUTION

Always handle printed circuit board assemblies by the edges. This will reduce the possibility of ESD damage to components and prevent contamination of exposed plating.

Test Equipment Usage and ESD

- Before connecting any coaxial cable to an analyzer connector, momentarily short the center and outer conductors of the cable together.
- Personnel should be grounded with a 1 megohm resistor-isolated wrist-strap before touching the center pin of any connector and before removing any assembly from the analyzer.
- Be sure that all analyzers are properly earth-grounded to prevent build-up of static charge.

For Additional Information about ESD

For more information about preventing ESD damage, contact the Electrical Over Stress/Electrostatic Discharge (EOS/ESD) Association, Inc. The ESD standards developed by this agency are sanctioned by the American National Standards Institute (ANSI).

Upgrade Contents

Table 1-1 Upgrade Contents

Part Number	Description	Quantity
n/a	Fan Assembly	1
N9041-60070	Dress Cover Assembly	1

This upgrade kits includes a new preassembled fan assembly to replace the existing one, along with a new instrument dress cover to match the new location of the cooling fans. This kit is intended to be used when either an older version of the assembly needs replacing, or when the owner of the instrument has requested to have this newly designed assembly installed to reduce the acoustic noise level of the instrument.

Tools Required

- TORX Driver, T-10
- TORX Driver, T-20
- Multi-Bit Torque Driver

Initial Instrument Functionality Check

Power on the instrument and allow it to complete its boot up process. Verify that there are no instrument messages that would indicate that there is an issue with either the instrument hardware or software. If there are any issues, investigate and fix the problem before continuing with this upgrade.

Option G2H Check

While the instrument is still powered on check to see if the instrument has option G2H installed. To do so press **System, Show System** and look on the System Information screen for option **G2H**.

If the instrument has option G2H installed it does not need this upgrade, as it should already have this hardware installed.

Upgrade Instructions

Hardware Removal

Dress Cover Removal

1. Turn the instrument off and disconnect the power cord.
2. Referring to **Figure 2**, remove the two screws (1) that attach the strap handles (2) from both sides of the instrument and remove the strap handles.

Figure 2 Dress Cover Removal

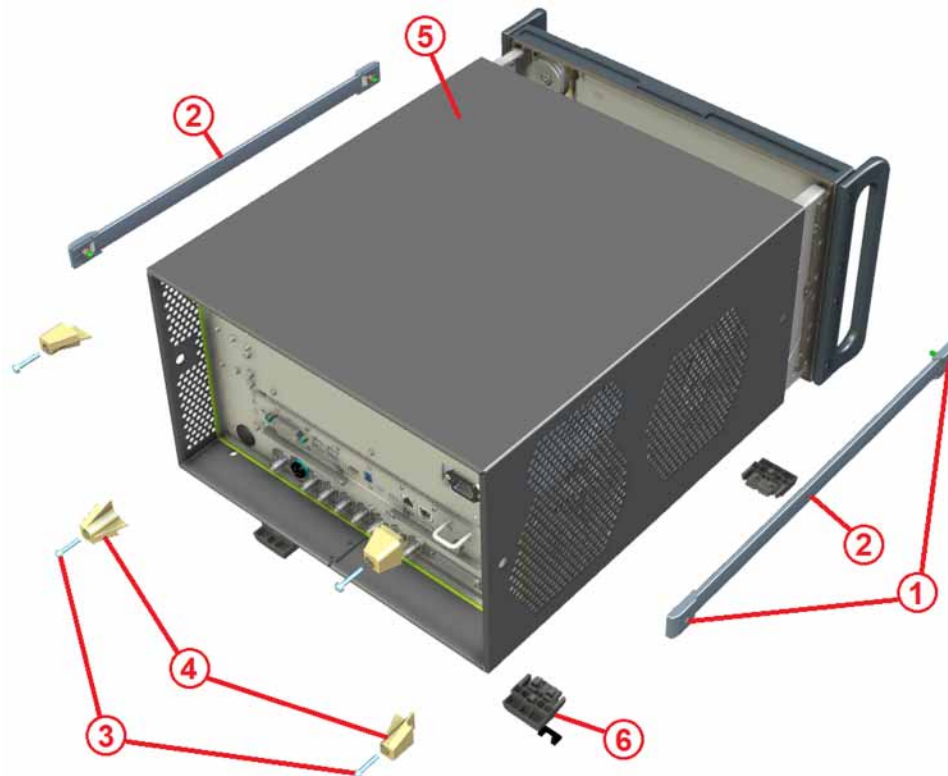

3. Remove the four rear feet (4) by removing the four screws (3) and washers that attach them.
4. Remove the four bottom feet (6) by first removing the locking keys and then lifting the tabs and sliding the foot toward the tabs.
5. Carefully slide the dress cover (5) off the instrument. This dress cover will not be reused.

Front Panel Removal

6. Referring to **Figure 3**, remove W1 (1) from the A7 Midplane board (2).

Figure 3 Disconnect W1 From A7 Midplane

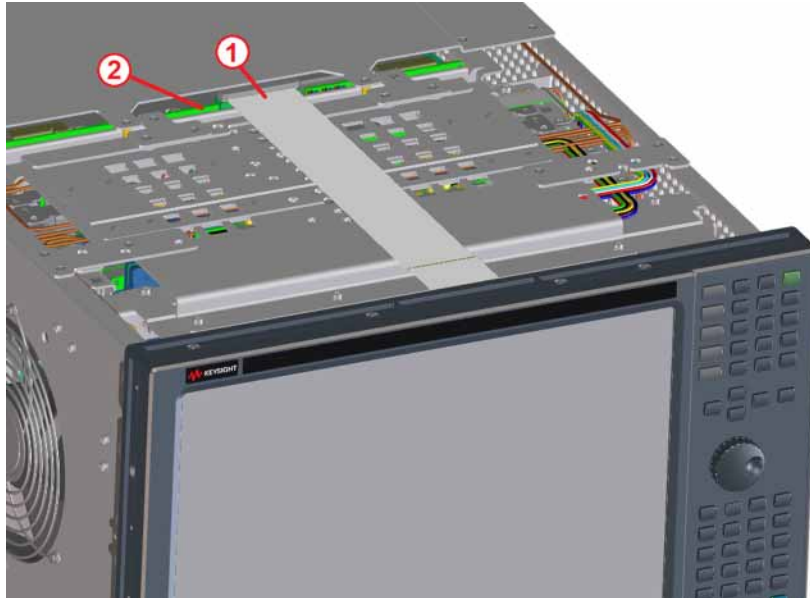

7. Referring to **Figure 4**, remove the seven flathead screws (1) from each side of the A1 Front Panel assembly and two flathead screws (2) from the bottom that attach it to the instrument.

Figure 4 Front Panel Screws

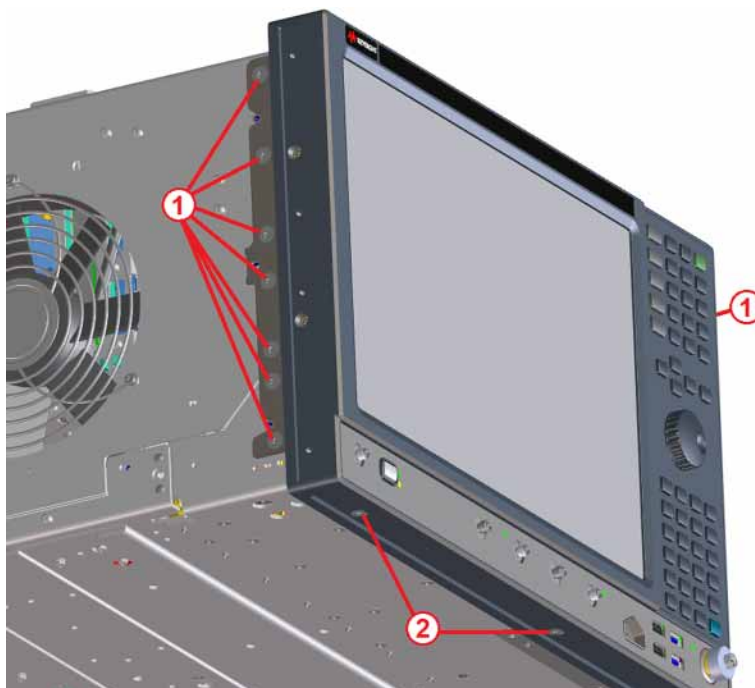

Upgrade Instructions

- Referring to **Figure 5**, slide the A1 Front Panel assembly away from the instrument enough to access and remove W2 (1) from the A1A3 Front Panel Daughter board.

Figure 5 W2 Access and Removal



- Set the A1 Front Panel assembly aside.

Old Fan Assembly Removal

10. Referring to **Figure 6**, remove the two flathead screws (1) and the two panhead screws (2) attaching the rear panel to the fan assembly.

Figure 6 Fan Assembly Removal

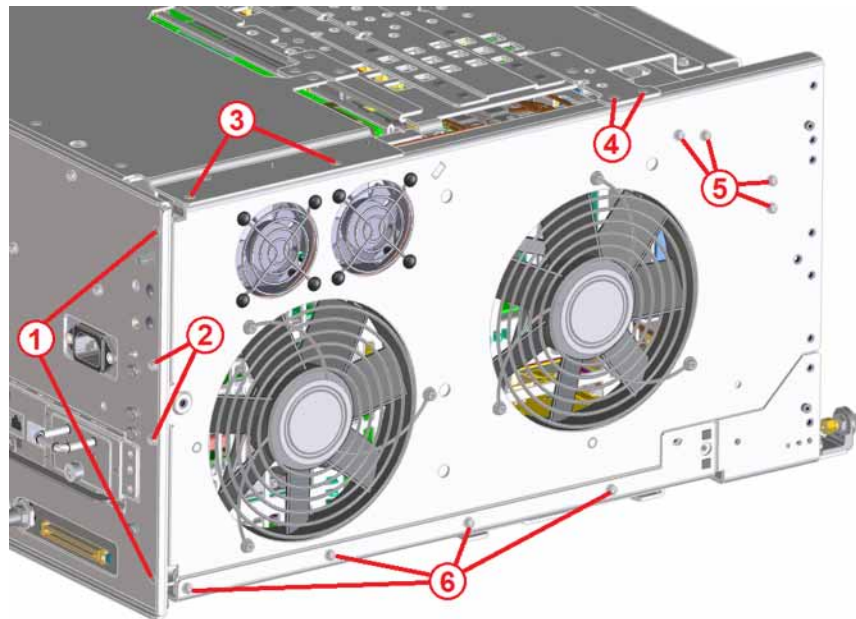

11. Remove the four flathead screws (3)(4) attaching the top brace and the card cage side brace to the fan assembly.
12. Remove the four panhead screws (5) attaching the fan assembly to the chassis front brace and the left front end brace stiffener.
13. Remove the four screws (6) attaching the fan assembly to the chassis base.
14. Carefully tilt the fan assembly out at the top, moving the coax cables going to the rear of the instrument out of the way if necessary.
15. Referring to **Figure 7**, unplug the wire harnesses for the two large fans (1) and the wire harness from the two small fans (2) from the side of the A7 Midplane board.

Figure 7 A7 Midplane Board Fan Connections

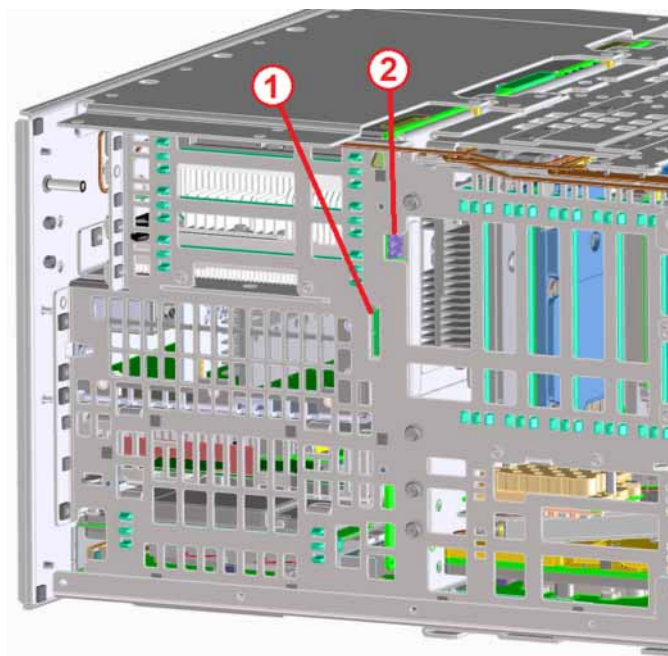

16.The old fan assembly can now be removed and discarded.

Hardware Installation

Fan Assembly Installation

1. Set the bottom edge of the new fan assembly into place in the instrument with the top tilting outward
2. Referring to [Figure 7](#), connect the two fan power supply connectors to the two lower connectors (1) on the side of the A7 Midplane board
3. Tilt the new fan assembly into place, arranging the coax cables along to top of the assembly as needed
4. Referring to [Figure 8](#), use the two flathead screws (1) to attach the fan assembly to the top brace and the two flathead screws (2) to attach it to the card cage side brace. Do not tighten the screws at this point.

Figure 8 Fan Assembly Installation

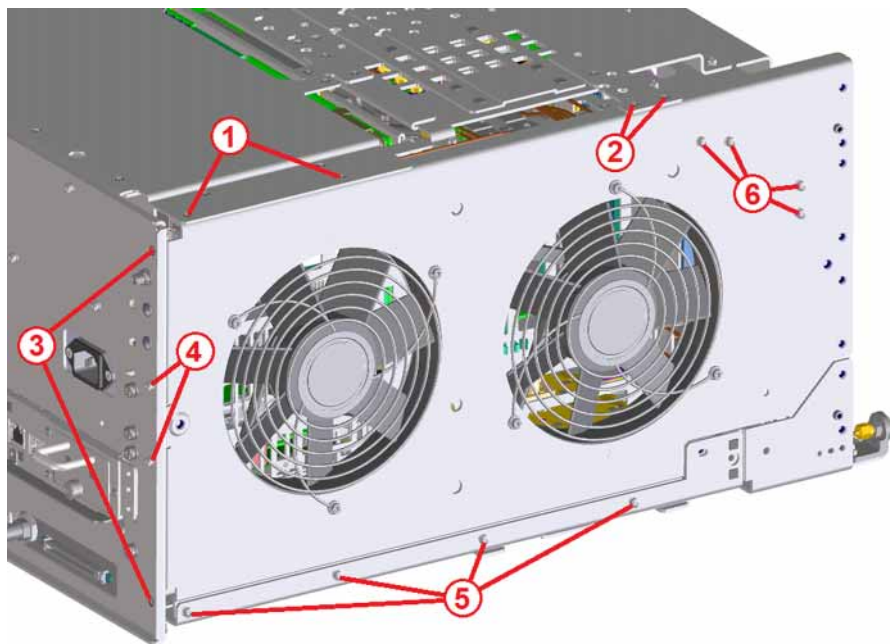

NOTE

Since the fan assembly is attached to so many other parts, it is best to loosely install all the screws before tightening any of them to the specified torque level.

5. Use the two flathead screws (3) and the two panhead screws (4) to attach the rear panel to the fan assembly. Do not tighten the screws at the point.
6. Use the four panhead screws (5) to attach the fan assembly to the chassis base. Do not tighten the screws at this point.
7. Use the four panhead screws (6) to attach the fan assembly to the chassis front brace and the left front end brace stiffener. Do not tighten the screws at this point.

Upgrade Instructions

8. Torque all sixteen screws that were installed in steps 4 through 7 to 9 in-lbs.

Front Panel Installation

9. Referring to **Figure 9**, position the A1 Front Panel assembly near the front of the instrument and attach W2 (1) to the A1A3 Front Panel Daughter board.

Figure 9 W2 Connection

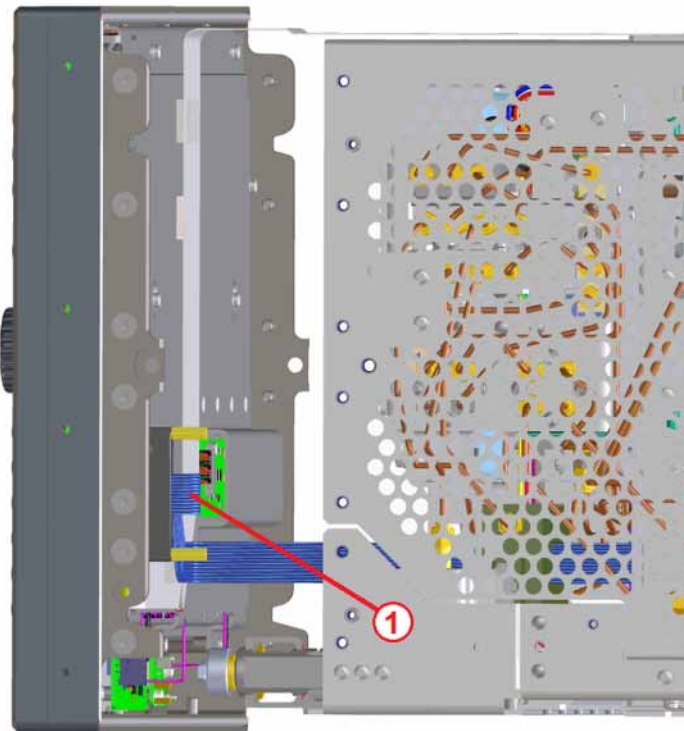

10. Referring to **Figure 10**, attach the A1 Front Panel assembly to the instrument and secure it with the seven flathead screws (1) on each side and the two flathead screws (2) on the bottom of the instrument. Torque all sixteen screws to 21 in-lbs.

Figure 10 A1 Front Panel Installation

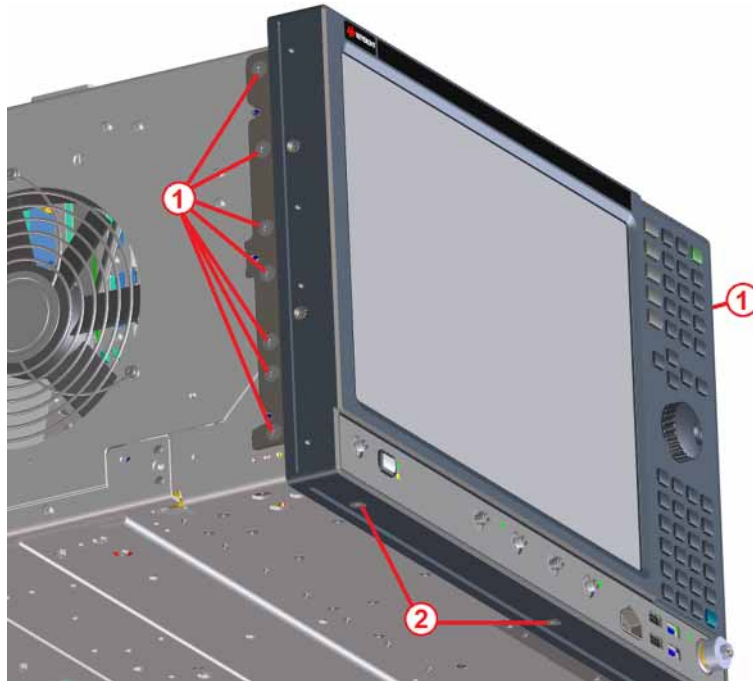

11. Referring to **Figure 11**, plug W1 (1) back into the A7 Midplane board.

Figure 11 W1 Connection to A7 Midplane Board

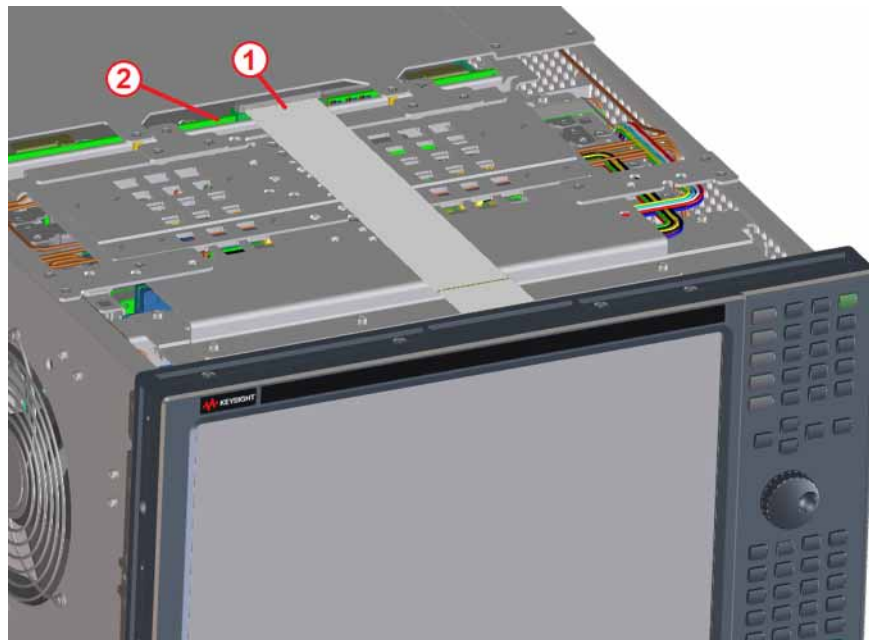

Upgrade Instructions

Verify Operation

The operation of the new fans should be verified before installing the instrument dress cover.

- 1. Connect the AC mains to the instrument and turn it on.**
- 2. Verify that both fans are spinning and sucking air into the instrument.**
- 3. Turn the instrument off and remove the AC mains.**

Instrument Button Up

Dress Cover Installation

1. Referring to **Figure 12**, carefully slide the outer cover (5) onto the instrument.

Figure 12 Dress Cover Installation

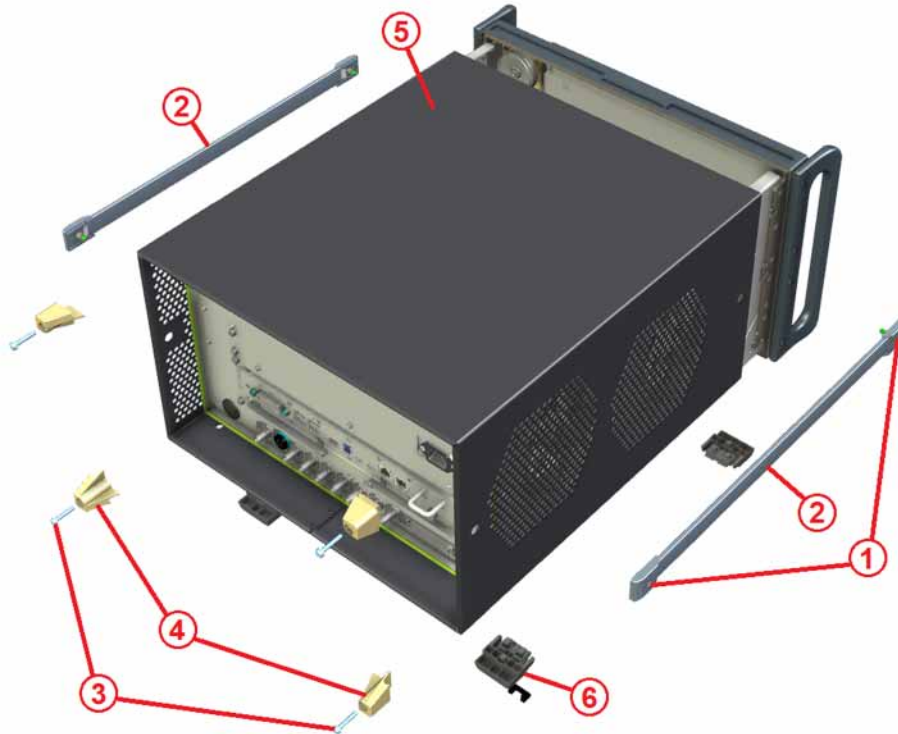

2. Attach the four rear feet (4) using the four panhead screws and washers (3). Torque the screws to 21 in-lbs.
3. Install the four bottom feet (6) along with the locking keys.
4. Install the strap handles (2) to both sides of the instrument using the two screws (1) at either end of the handles. Torque the screws to 21 in-lbs.

Adjustments and Performance Verification

Adjustments and Performance Verification

Manual Procedures Required

Front Panel Key Test¹

Front Panel Display Test¹

Front Panel Touch Test¹

Automated Utilities Required

None

Automated Adjustments Required

None

Automated Performance Verification Testing Required

Residual Response

Displayed Average Noise Level

Phase Noise

1. See Chapter 18, “Service Menus” of the N9042B Service Guide for direction on performing this manual procedure.



This information is subject to change without notice.

© Keysight Technologies 2023

Edition 1, January 2023

N9042-90013

www.keysight.com