M9035A PXIe Embedded Controller



Notices

© Keysight Technologies, Inc. 2021-2025

No part of this manual may be reproduced in any form or by any means (including electronic storage and retrieval or translation into a foreign language) without prior agreement and written consent from Keysight Technologies, Inc. as governed by United States and international copyright laws.

Manual Part Number

M9035-90001

Edition

Third Edition, February 2025
Published in USA

Keysight Technologies, Inc.
1400 Fountaingrove Parkway
Santa Rosa, CA 95403 USA

Trademarks

AXIe is a registered trademark of the AXIe Consortium.

PXI is a registered trademark of the PXI Systems Alliance.

PICMG[®], Compact PCI[®], and AdvancedTCA[®] are registered trademarks of the PCI Industrial Computer Manufacturers Group.

PCI-SIG[®], PCI Express[®], and PCIe[®] are registered trademarks of PCI-SIG.

Sales and Technical Support

To contact Keysight for sales and technical support, refer to the support links on the following Keysight websites:
www.keysight.com/find/M9035A (product-specific information and support, software and documentation updates)
www.keysight.com/find/assist (world-wide contact information for repair and service)

Declaration of Conformity

Declarations of Conformity for this product and for other Keysight products may be downloaded from the Web. Go to <http://www.keysight.com/go/conformity> and click on “Declarations of Conformity.” You can then search by product number to find the latest Declaration of Conformity.

Technology Licenses

The hardware and/or software described in this document are furnished under a license and may be used or copied only in accordance with the terms of such license.

Warranty

THE MATERIAL CONTAINED IN THIS DOCUMENT IS PROVIDED “AS IS,” AND IS SUBJECT TO BEING CHANGED, WITHOUT NOTICE, IN FUTURE EDITIONS. FURTHER, TO THE MAXIMUM EXTENT PERMITTED BY APPLICABLE LAW, KEYSIGHT DISCLAIMS ALL WARRANTIES, EITHER EXPRESS OR IMPLIED, WITH REGARD TO THIS MANUAL AND ANY INFORMATION CONTAINED HEREIN, INCLUDING BUT NOT LIMITED TO THE IMPLIED WARRANTIES OF MERCHANTABILITY AND FITNESS FOR A PARTICULAR PURPOSE. KEYSIGHT SHALL NOT BE LIABLE FOR ERRORS OR FOR INCIDENTAL OR CONSEQUENTIAL DAMAGES IN CONNECTION WITH THE FURNISHING, USE, OR PERFORMANCE OF THIS DOCUMENT OR OF ANY INFORMATION CONTAINED HEREIN. SHOULD KEYSIGHT AND THE USER HAVE A SEPARATE WRITTEN AGREEMENT WITH WARRANTY TERMS COVERING THE MATERIAL IN THIS DOCUMENT THAT CONFLICT WITH THESE TERMS, THE WARRANTY TERMS IN THE SEPARATE AGREEMENT SHALL CONTROL.

Keysight Technologies does not warrant third-party system-level (combination of chassis, controllers, modules, etc.) performance, safety, or regulatory compliance unless specifically stated.

DFARS/Restricted Rights Notices

If software is for use in the performance of a U.S. Government prime contract or subcontract, Software is delivered and licensed as “Commercial computer software” as defined in DFAR 252.227-7014 (June 1995), or as a “commercial item” as defined in FAR 2.101(a) or as “Restricted computer software” as defined in FAR 52.227-19 (June 1987) or any equivalent agency regulation or contract clause. Use, duplication or disclosure of Software is subject to Keysight Technologies’ standard commercial license terms, and non-DOD Departments and Agencies of the U.S. Government will receive no greater than Restricted Rights as defined in FAR 52.227-19(c)(1-2) (June 1987). U.S. Government users will receive no greater than Limited Rights as defined in FAR 52.227-14 (June 1987) or DFAR 252.227-7015 (b)(2) (November 1995), as applicable in any technical data.

Safety Information

The following general safety precautions must be observed during all phases of operation of this instrument. Failure to comply with these precautions or with specific warnings or operating instructions in the product manuals violates safety standards of design, manufacture, and intended use of the instrument. Keysight Technologies assumes no liability for the customer's failure to comply with these requirements.

General

This product has been designed and tested in accordance with accepted industry standards and has been supplied in a safe condition. The documentation contains information and warnings that must be followed by the user to ensure safe operation and to maintain the product in a safe condition.

Before Applying Power

Verify that all safety precautions are taken. Make all connections to the unit before applying power. Note the external markings described under "Safety Symbols".

Ground the Instrument

Keysight chassis' are provided with a grounding-type power plug. The instrument chassis and cover must be connected to an electrical ground to minimize shock hazard. The ground pin must be firmly connected to an electrical ground (safety ground) terminal at the power outlet. Any interruption of the protective (grounding) conductor or disconnection of the protective earth terminal will cause a potential shock hazard that could result in personal injury.

Do Not Operate in an Explosive Atmosphere

Do not operate the module/chassis in the presence of flammable gases or fumes.

Do Not Operate Near Flammable Liquids

Do not operate the module/chassis in the presence of flammable liquids or near containers of such liquids.

Cleaning

To prevent electrical shock, disconnect the instrument from mains before cleaning. Use a dry cloth or one slightly dampened with water to clean the external case parts. Do not attempt to clean internally.

Do Not Remove Instrument Cover

Only qualified, service-trained personnel who are aware of the hazards involved should remove instrument covers. Always disconnect the power cable and any external circuits before removing the instrument cover.

Keep away from live circuits

Operating personnel must not remove equipment covers or shields. Procedures involving the removal of covers and shields are for use by service-trained personnel only. Under certain conditions, dangerous voltages may exist even with the equipment switched off. To avoid dangerous electrical shock, DO NOT perform procedures involving cover or shield removal unless you are qualified to do so.

DO NOT operate damaged equipment

Whenever it is possible that the safety protection features built into this product have been impaired, either through physical damage, excessive moisture, or any other reason, REMOVE POWER and do not use the product until safe operation can be verified by service-trained personnel. If necessary, return the product to an Keysight Technologies Sales and Service Office for service and repair to ensure the safety features are maintained.

DO NOT block the primary disconnect

The primary disconnect device is the appliance connector/power cord when a chassis used by itself, but when installed into a rack or system the disconnect may be impaired and must be considered part of the installation.

Do Not Modify the Instrument

Do not install substitute parts or perform any unauthorized modification to the product. Return the product to an Keysight Sales and Service Office to ensure that safety features are maintained.

In Case of Damage

Instruments that appear damaged or defective should be made inoperative and secured against unintended operation until they can be repaired by qualified service personnel

CAUTION

Do NOT block vents and fan exhaust: To ensure adequate cooling and ventilation, leave a gap of at least 50mm (2") around vent holes on both sides of the chassis.

Do NOT operate with empty slots: To ensure proper cooling and avoid damaging equipment, fill each empty slot with an AXle filler panel module.

Do NOT stack free-standing chassis: Stacked chassis should be rack-mounted.

All modules are grounded through the chassis: During installation, tighten each module's retaining screws to secure the module to the chassis and to make the ground connection.

WARNING

Operator is responsible to maintain safe operating conditions. To ensure safe operating conditions, modules should not be operated beyond the full temperature range specified in the Environmental and physical specification. Exceeding safe operating conditions can result in shorter lifespan, improper module performance and user safety issues. When the modules are in use and operation within the specified full temperature range is not maintained, module surface temperatures may exceed safe handling conditions which can cause discomfort or burns if touched. In the event of a module exceeding the full temperature range, always allow the module to cool before touching or removing modules from the chassis.

Safety and Regulatory Symbols









CAUTION

A CAUTION denotes a hazard. It calls attention to an operating procedure or practice, that, if not correctly performed or adhered to could result in damage to the product or loss of important data. Do not proceed beyond a CAUTION notice until the indicated conditions are fully understood and met.

WARNING

A WARNING denotes a hazard. It calls attention to an operating procedure or practice, that, if not correctly performed or adhered to, could result in personal injury or death. Do not proceed beyond a WARNING notice until the indicated conditions are fully understood and met.

Products may display the following symbols:

-  Warning, risk of electric shock
-  Refer to manual for additional safety information.
-  Earth Ground.
-  Chassis Ground.
-  Alternating Current (AC).
-  Standby Power. Unit is not completely disconnected from AC mains when switch is in standby.
-  Antistatic precautions should be taken.
-  CAT I IEC Measurement Category I, II, III, or IV
CAT II
CAT III
CAT IV

For localized Safety Warnings, Refer to Keysight Safety document (p/n 9320-6792).



The CSA mark is a registered trademark of the Canadian Standards Association and indicates compliance to the standards laid out by them. Refer to the product Declaration of Conformity for details.



Notice for European Community: This product complies with the relevant European legal Directives: EMC Directive and Low Voltage Directive .



The Regulatory Compliance Mark (RCM) mark is a registered trademark. This signifies compliance with the Australia EMC Framework regulations under the terms of the Radio Communication Act of 1992.

ICES/NMB-001

ICES/NMB-001 indicates that this ISM device complies with the Canadian ICES-001.

Cet appareil ISM est conforme a la norme NMB-001 du Canada.



This symbol represents the time period during which no hazardous or toxic substance elements are expected to leak or deteriorate during normal use. Forty years is the expected useful life of this product.

The UK conformity mark is a UK government owned mark. Products showing this mark comply with all applicable UK regulations.

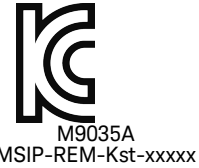

South Korean Class A EMC Declaration. this equipment is Class A suitable for professional use and is for use in electromagnetic environments outside of the home.

A 급 기기 (업무용 방송통신기자재) 이 기기는 업무용 (A 급) 전자파적합기로서 판 매자 또는 사용자는 이 점을 주의하시기 바라 며 , 가정외의 지역에서 사용하는 것을 목적으로 합니다.



Waste Electrical and Electronic Equipment (WEEE) Directive 2002/96/EC

This product complies with the WEEE Directive (2002/96/EC) marking requirement. The affixed product label (see below) indicates that you must not discard this electrical/electronic product in domestic household waste.

Product Category: With reference to the equipment types in the WEEE directive Annex 1, this product is classified as a "Monitoring and Control instrumentation" product.

Do not dispose in domestic household waste.

To return unwanted products, contact your local Keysight office for more information.



Contents

Introduction	9
Related Documentation	9
M9035A at a Glance	10
Front Panel LED Indicators.	11
Step 1: Unpack and Inspect the Module	12
ESD	12
Inspect for Damage	12
If you need to return the module for service	13
Step 2: Verify Shipment Contents.	14
Step 3: Install the M9035A Embedded Controller	15
Removing the M9035A from the Chassis.	17
Power On Sequence	17
Power Off Sequence	17
Power Down Modes	18
Controller and Chassis Drivers.	18
Step 4: Review Windows Configuration	19
Windows OS Versions.	19
Microsoft Windows OS is Activated	19
Windows Security.	19
Windows Update	20
User Data Backup.	21
System Backup and Recovery	21
Auto Login.	21
Default Administrator Password: Keysight4u!	21
Change Administrator Password	21
Remote Desktop Connection	22
Step 5: Run Keysight IO Libraries Suite	23
Step 6. Verify Operation	24
Step 7: Install User Application Modules in the PXIe Chassis	25
Install application module drivers (if necessary)	25
Upgrading from the M9036A	26
Controller Operating System.	27
M9018 PXIe Chassis PCIe Link Configuration.	27
M9035A Accessories	29
Environmental Operating Conditions	30

Introduction

Keysight's M9035A is a Windows PC that fits in slot 1 of a PXIe chassis. It is a 3U, 4-slot PXIe Embedded Controller providing:

- Intel® CoffeeLake Quad-Core i3-8100H processor with UEFI BIOS
- 16 GB standard (or optional 32 GB) 260-pin DDR4-2666 RAM Memory*
- 256 GB SATA 2.5 inch solid state drive (SSD) front panel removable
- Integrated IO on the front panel includes two Gigabit Ethernet ports, four USB 2.0 ports†, two USB 3.0 ports, GPIB connector, two DisplayPort video ports (also known as DisplayPort++)
- Preloaded with Keysight IO Libraries and Microsoft Windows operating system
- Pre-installed IVI drivers for the Keysight PXIe chassis

Related Documentation

A Windows OS and M9035A drivers were installed at the factory. All the drivers required to operate the controller and chassis were installed. No additional drivers are required, until you add modules and instruments.

Complete M9035A documentation, as well as the PXIe Chassis Family documentation, is pre-installed on the M9035A SSD. It can be found from the Windows Start menu under Keysight. Descriptions of the PXIe Chassis Family can be found at: www.keysight.com/find/pxie-chassis.

Adobe Reader is required to view the documentation supplied on the M9035A. It is available free at www.adobe.com. You should install this on your M9035A prior to attempting to open a PDF file.

For the latest M9035A specifications, go to: www.keysight.com/find/M9035A.

For the IVI trigger driver, help file, program examples, etc. go to:

C:\ProgramFiles\IVI Foundation\IVI\Drivers\KtMTrig

or

C:\ProgramFiles (x86)\IVI Foundation\IVI\Drivers\KtMTrig

To start the Soft Front Panel interface, from the Window's Start menu, under Keysight, look for Embedded Controller SFP.

* The M9035A has two 204-pin, DDR4-2400 SODIMM sockets. The standard M9035A configuration is a single 16 GB memory module with a factory option to provide 32 GB memory. To use the full 16 GB memory, a 64-bit OS must be used.

† The USB 2.0 and 3.0 ports do not support the USB Battery Charging specification. Do not connect non-standard or defective USB devices.

M9035A at a Glance

The following figure shows the front panel for the M9035A. Detailed information about the module follows in this manual.

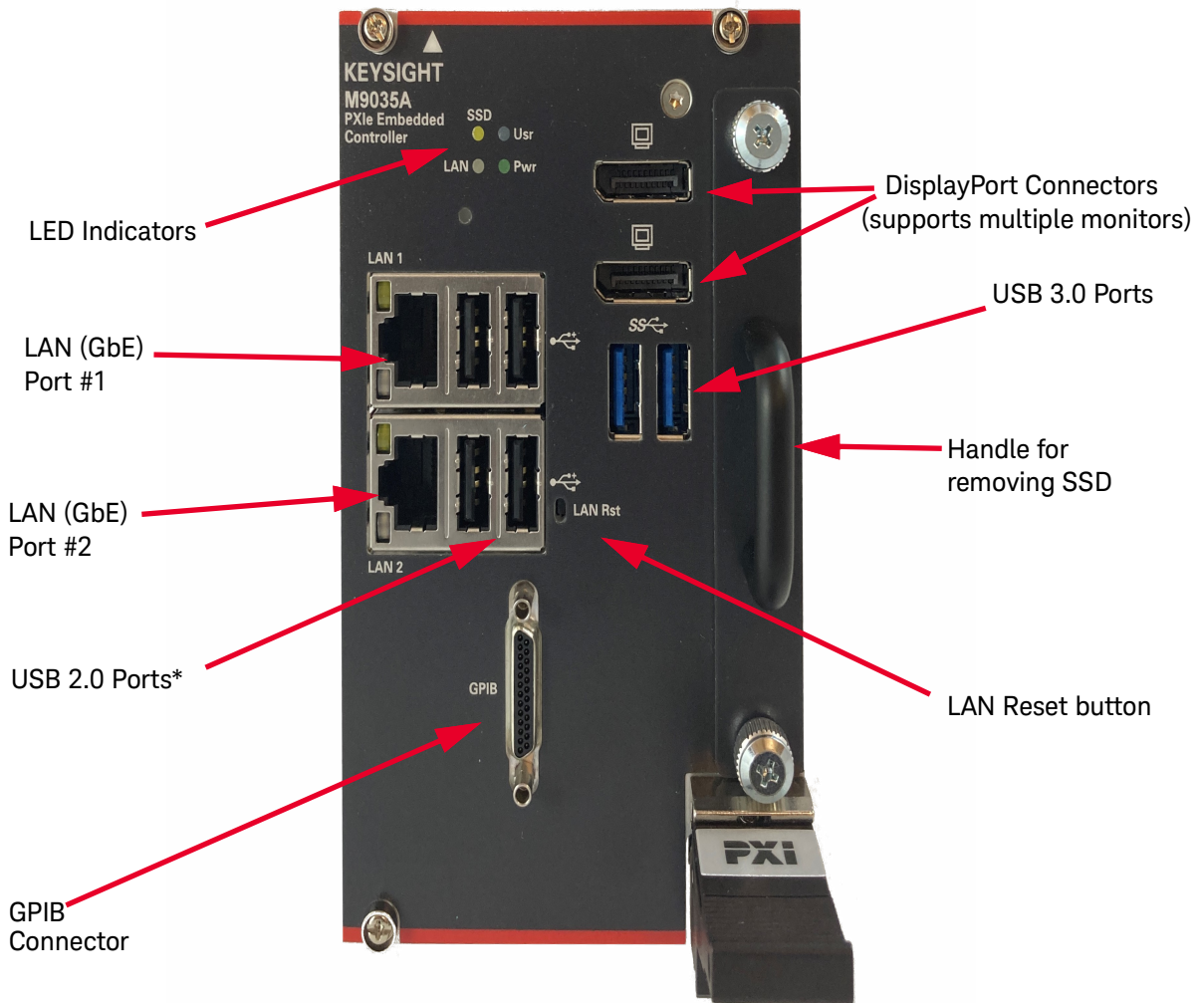

* The USB 2.0 and 3.0 ports do not support the USB Battery Charging specification. Do not connect non-standard or defective USB devices.

Front Panel LED Indicators

The following table lists the LEDs on the front panel and a brief description of their use and what they indicate.

LED Indicator	Color	Description
PWR	Green	If the LED is on, the power supply to the controller is good and the system should boot.
SSD	Amber	When the Solid State Drive (SSD) is active, the LED will flash.
LAN	N/A	These two LEDs are reserved for Keysight use only. The LEDs should never turn on or flash.
USR	N/A	

Gigabit Ethernet (GbE) LEDs

Speed and Link
 10Mbps: off
 100Mbps: **Green**
 1000Mbps: **Amber**

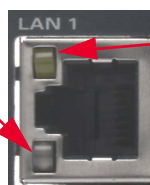

Active: **Amber**
 Blinks when accessing IO

**RJ-45
 connector**

Both LEDs off indicate that network link is not established or system is powered off.

LAN RST Button

The LAN RST button is reserved for Keysight use only. Depressing the LAN RST button has no effect.

Step 1: Unpack and Inspect the Module

CAUTION

Keysight's PXIe Modules are shipped in materials that prevent static electricity damage. The modules should only be removed from the packaging in an anti-static area ensuring that correct anti-static precautions are taken. Store all modules in anti-static envelopes when not in use.

ESD

Electrostatic discharge (ESD) can damage or destroy electronic components. All work on electronic assemblies should be performed at a static-safe work station. The following figure shows an example of a static-safe work station using two types of ESD protection. Purchase acceptable ESD accessories from your local supplier.

- Conductive table-mat and wrist-strap combination.
- Conductive floor-mat and heel-strap combination.

Both types, when used together, provide a significant level of ESD protection. Of the two, only the table-mat and wrist-strap combination provides adequate ESD protection when used alone. To ensure user safety, the static-safe accessories must provide at least 1 M Ω of isolation from ground.

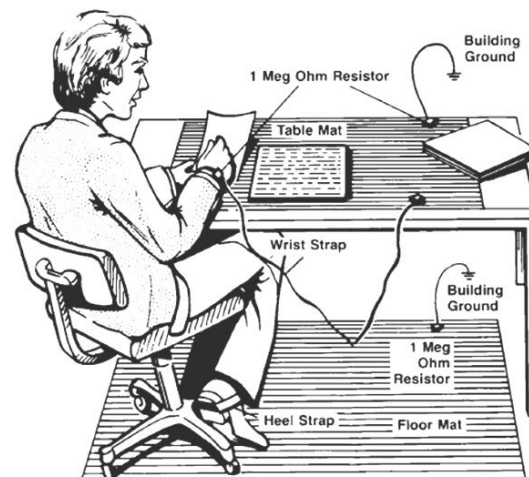

Inspect for Damage

After unpacking the embedded controller, carefully inspect it for any shipping damage. Report any damage to the shipping agent immediately, as such damage is not covered by the warranty.

CAUTION

To avoid damage when handling a module; do not touch exposed connector pins.

Step 1: Unpack and Inspect the Module

If you need to return the module for service

Should it become necessary to return a Keysight module for repair or service, follow the steps below:

- 1** Review the warranty information shipped with your product.
- 2** Contact Keysight to obtain a return authorization and return address. If you need assistance finding Keysight contact information go to www.keysight.com/find/assist (worldwide contact information for repair and service) or refer to the Technical **Support** information on the product web page at: www.keysight.com/find/M9035A.
- 3** Write the following information on a tag and attach it to the malfunctioning equipment.
 - Name and address of owner. A Post Office box is not acceptable as a return address.
 - Product model number (for example, M9035A)
 - Product serial number (for example, TWXXXXXXXX). The serial number label is located on the side of the module.
 - A description of failure or service required.
- 4** You should remove the SSD and RAM modules prior to returning the M9035A for service. Refer to the *Keysight M9035A User Guide* for detailed instructions. The service center has its own SSD and RAM modules for testing purposes
- 5** Carefully pack the module in its original ESD bag and carton. If the original carton is not available, use bubble wrap or packing peanuts, place the instrument in a sealed container and mark the container “FRAGILE”.
- 6** On the shipping label, write ATTENTION REPAIR DEPARTMENT and the service order number (if known).

NOTE

If any correspondence is required, refer to the product by model number and serial number.

Step 2: Verify Shipment Contents

Your shipment should have included the following:

- The Keysight M9035A Embedded Controller module that you ordered.
- This printed manual (*M9035A PXIe Embedded Controller Startup Guide*).

The Microsoft Windows operating system and the latest version of Keysight IO Libraries Suite, and all necessary driver software were installed for you at the factory.

NOTE

The most current version of Keysight IO Libraries is required prior to installing and running any other software. The latest version can be downloaded from: www.keysight.com/find/iosuite.

No other drivers are required to operate the controller module. However, your application modules may require drivers. If possible, you should connect the M9035A to the Internet and download drivers from the original source. Alternately, you can transfer the drivers on a USB memory stick and install them accordingly.

NOTE

A GPIB cable is NOT supplied with the controller. Note that the GPIB cable is a standard micro type 2 GPIB cable with standard pin wiring and is not compatible with the M9036A Embedded Controller GPIB cable. It is available from Keysight as an accessory cable, part number Y1260A.

WARNING

Safety of any system incorporating the equipment is the responsibility of the assembler of the system.

Step 3: Install the M9035A Embedded Controller

The Keysight M9035A has been designed for easy installation. However, the following standard precautions, installation procedures, and general information must be observed to ensure proper installation and to prevent damage to the board, other system components, or injury to personnel.

Keysight's M9035A can operate with all of the PCIe fabric configurations found on a Keysight PXIe chassis as well as the standard 4x4 fabric used on non-Keysight PXIe chassis.

CAUTION

The following safety precautions must be observed when installing or operating the Keysight M9035A. Exercise care when handling the module as the heat sink can get very hot. Do not touch the heat sink when installing or removing the module. The board should not be placed on any surface or in any form of storage container until the board and heat sink have cooled to room temperature.

NOTE

Embedded controllers, such as the M9035A, can only be installed in System Controller slot (Slot 1) of the chassis.

NOTE

M9018 PXIe Chassis Backplane Switch:

The default position of the chassis backplane switch is to the left. However, if a Keysight M9021A Cable Interface module was previously installed in the M9018 chassis, then the backplane switch was moved to the right. To use the M9035A Embedded Controller in the M9018 chassis, the slide switch should be in the left position before installing the controller. Refer to the M9018 chassis documentation for more information.

Ensure the M9018A/B backplane switch is in the left position

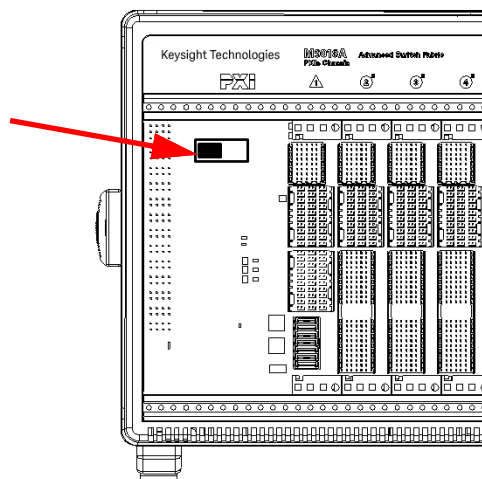

WARNING

To ensure mandatory safety requirements are being met, the module must be installed in a chassis which has been certified and marked by a Nationally Recognized Testing Lab (such as CSA, UL, TUV, ETL etc.) in which all the means of protection are properly implemented. NOTE: CE marking alone is not adequate.

Follow these steps to install the M9035A Embedded Controller in a PXIe chassis.

NOTE

Some non-Keysight PXIe chassis manufacturers install small chassis stops just to the left of the slot 1 guide rails (both top and bottom). Refer to the photo below. These must be removed prior to installing the M9035A Embedded Controller. They snap in and are easily pulled out.

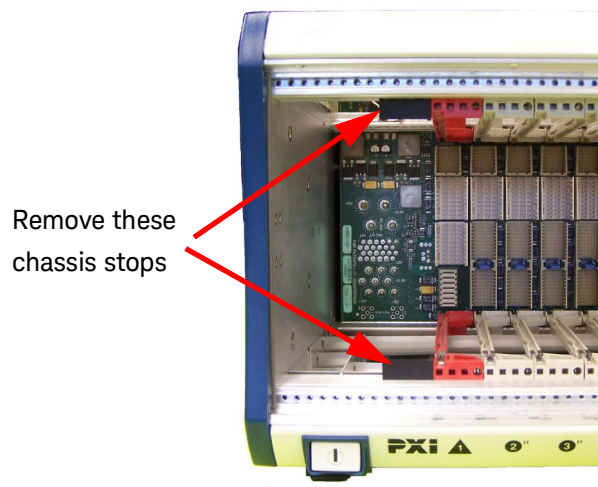

- 1 Ensure the PXIe chassis is turned off. The chassis should be plugged into an AC power source; the AC power cord grounds the chassis and protects it from electrical damage while modules are installed.
- 2 On the chassis, set the rear panel **INHIBIT** switch to **DEF**.
- 3 Remove the screw protection caps from the four M9035A retaining screws.
- 4 Push down on the controller's ejector/injector handle.
- 5 Carefully align the M9035A board edges with the chassis guide rails for slot 1 (red guide rails) and insert the controller into the guide rails.
- 6 Push inward on the module until it is firmly seated in the chassis. (Do not force the handle if there is resistance; this may damage the connectors and/or backplane.)
- 7 Pull up on the ejector/injector handle to firmly seat the controller.
- 8 Tighten the module's four (4) captive retaining screws.

Step 3: Install the M9035A Embedded Controller

- 9 Connect other peripherals (such as the keyboard, mouse, monitor, LAN cable, etc.) to the Embedded Controller.
- 10 Power up the PXIe chassis. Verify that the chassis fans are operating and free of obstructions that may restrict air flow.

Removing the M9035A from the Chassis

To remove the M9035A controller, reverse the previous procedure. Shut down the operating system to power-down the chassis. Loosen the four captive screws, press down on the ejector/injector handle and pull outwards to release the module from the backplane. Pull the module towards you until it is free of the chassis.

Power On Sequence

The M9035A controller, like any PC, will boot with the installed operating system. Refer to the *M9035A User Guide* for detailed power on and configuration sequence information.

NOTE

Depending on the system configuration, the BIOS may take 90 seconds (or longer) to boot. During this time, the Keysight splash screen (the Keysight logo) is present and it may appear that nothing is happening. This is generally caused by the inclusion of certain devices in the switch fabric (such as a RAID controller) that require a longer time for PCI enumeration.

WARNING

If this product is not used as specified, the protection provided by the equipment could be impaired. This product must be used in a normal condition (in which all means for protection are intact) only.

Power Off Sequence

As with any PC, Windows-based instruments should not be shutdown by either turning off the power via an external power source or by pulling the power plug out from the chassis rear panel. This could corrupt the operating system. One method to shut down the controller is to execute the Windows shutdown process which shuts down the M9035A controller then turns off the PXIe chassis. A second method, if the chassis rear panel INHIBIT switch is set to DEF, is to momentarily press the front panel button. Either method shuts down the M9035A safely.

Power Down Modes

Keysight's M9035A defaults to the Windows Ultimate Performance Power Plan. This plan does not allow the controller display to shut off or the controller to enter a sleep mode.

NOTE

You cannot enable the Microsoft Windows Sleep mode. It is disabled to prevent the controller from entering the Sleep mode while it is running a user test program.

If you have a USB keyboard with a Sleep button (sometimes this is a key with a crescent moon logo), do not use it.

Controller and Chassis Drivers

All of the M9035A Controller and Keysight PXIe Chassis drivers were installed on your controller at the factory. However, you should periodically check the M9035A web page (www.keysight.com/find/M9035A) for the most current M9035A software and drivers. Likewise, check the PXIe chassis web page for the latest PXIe Chassis Family Driver.



NOTE

If you already have a Keysight M9036A Embedded Controller and you want to upgrade to an M9035A, be aware that the IVI API drivers are not the same. You will need to update any programs/applications you have written and rebuild them.

Step 4: Review Windows Configuration

Windows OS Versions

You can identify the version of Windows you are running by looking at the start button:

Start Button ICON	Windows OS Version
	Windows 10 IoT Enterprise 2019 LTSC Value (64-bit)
	Windows 11 IoT Enterprise 2024 LTSC 24H2 (64-bit)

Microsoft Windows OS is Activated

Keysight ensures that your copy of Microsoft Windows operating system is activated at the time it ships from the factory. However, the first time you turn on the M9035A and Windows starts, you must accept the End User License Agreement (EULA). A copy of the Windows EULA is in the M9035A at: **C:/Program Files (x86)\Keysight\M9035A Embedded Controller**

If you want to verify Windows Activation, do the following:

- 1 In “Windows 10/Windows 11”, right-click Windows **Start** button, then click **System**.
- 2 Scroll down to the bottom of the screen. Under **Windows Activation**, you can view the activation status.

Windows Security

If your system is connected to the Internet, you should take the following steps to ensure the operating system is protected:

- Use an Internet firewall
- Get the latest Windows updates
- Install and use up-to-date anti-virus software.

Windows Update

The factory default setting for Windows Automatic Updates is to check for updates and notify the user if updates are available. It will not automatically install updates. This ensures that your M9035A is not modified, unless you accept an update.

In “Windows 10/Windows 11”, you can change the setting or manually updating the OS by right-clicking **Start**, click **Settings**, and then click on **Update & Security**.

CAUTION

Windows Automatic Update is turned off by default. You may choose to turn Windows Automatic Update on after starting the operating system. However, Keysight cannot be held responsible for changes to the system caused by the automatic update process. Enabling automatic Windows updates exposes the controller to periodic OS changes and possible new system behaviors.

NOTE

Downloading and installing Windows Updates can be network and CPU intensive (impacting system performance) and some Windows Updates automatically reboot the controller. Therefore, Windows updates should be performed when the system is not in normal use.

NOTE

There is no 3rd party anti-virus software included with your controller. Anti-virus application software is the customer's responsibility. Having anti-virus software installed may have a slight impact on system performance.

CAUTION

A Microsoft Windows update might happen without user acceptance. The factory image on your Embedded Controller has a default configuration set to notify you before downloading and installing any updates. However, Microsoft Windows will sometimes install updates without notifying the user, even if configured to not perform an update. If your application requires that Windows does not perform updates, please work with your IT department to determine the best solution. They may suggest isolating your network or setting up a firewall.

User Data Backup

All user data should be regularly backed up to an external memory device. This can be done across a network or to a USB device. Your IT department may already have a backup strategy which is suitable for the system and data. Also, user data back up should be done just prior to sending the controller back to Keysight for service.

System Backup and Recovery

A Microsoft Windows operating system is the only operating system installed on your M9035A. There is a small system partition for the Keysight Recovery System on the SSD. During the boot process, you are given the choice to boot to Windows normally or boot from the recovery partition. Refer to the M9035A User Guide for detailed information.

Auto Login

Your M9035A Windows default behavior is to automatically login to the Administrator account every time it boots. You do not need to type a password.

Default Administrator Password: **Keysight4u!**

The Keysight standard for the Administrator password is **Keysight4u!** Your M9035A Administrator account is most likely is set with this password. If it is not set with this password, then there is no password.

Change Administrator Password

The default Administrator password is public knowledge. Keysight recommends that you change your password for improved security.

NOTE

Anyone who knows your current Administrator password can change the password. When you change your password you must enter the current password. Because Auto Login is enabled, you may not notice if someone changed the password.

How to change your password for “Windows 10/Windows 11”:

1. Click the **Start** button at the bottom left of your screen.
2. Click **Settings** from the list to the left.
3. Select **Accounts**.
4. Select **Sign-in options** from the menu.
5. Click on **Change** under Change your account password.

Remote Desktop Connection

The standard Microsoft application “Remote Desktop Connection” allows you to remotely login to the M9035A across the LAN from another computer. It only works if the accounts have passwords.

If your Administrator password is set on your M9035A, then the Remote Desktop Connection is enabled by default.

NOTE

Anyone with network access to your M9035A can control your M9035A using the user name of local\Administrator and the publicly known default password of: **Keysight4u!**

For your environment, you must determine if this is a useful feature or a security problem. If it’s a security problem, then change the password or disable Remote Desktop Connection.

Step 5: Run Keysight IO Libraries Suite

Keysight IO Libraries Suite was installed at the factory in your embedded controller. If you need to re-install it or want to update to a later version, follow the instructions below. It includes the Keysight Connection Expert, the IVI Shared Components, and the VISA Shared Components.

NOTE

Keysight IO Libraries version was pre-installed at the factory. The latest version can be downloaded from:
www.keysight.com/find/iosuite.

NOTE

Keysight IO Libraries installs the IVI Shared Components and VISA Shared Components on your controller.

If Connection Expert is not already running, run it now to verify your I/O configuration. From the Windows **Start** button, select **Keysight Connection Expert**. Alternately, you can click the icon () from the Windows messaging area in the lower right corner of your desktop.

Locate your interfaces and instruments in the Keysight Connection Expert Instruments Tab.

NOTE

All drivers necessary for the operation of the M9035A are pre-installed at the factory.

Step 6. Verify Operation

If your M9035A Embedded Controller boots to Windows and the front panel status LEDs do not indicate an error (see “[Front Panel LED Indicators](#)” on page 11), then the controller is working normally.

Step 7: Install User Application Modules in the PXIe Chassis

The PXIe chassis accepts modules conforming to the PXI standard, which can be installed in available slots in the chassis. These may include:

- PXI instrument or switch modules
- PXIe filler panel modules (PXIe chassis are shipped with filler panels for all slots, except for Slot 1; you may need to remove filler panels from covered slots.)

Turn off the chassis prior to installing modules but do not unplug the chassis from the AC power source; the AC power cord grounds the chassis and protects it from electrical damage when modules are installed or removed.

CAUTION

- **Static Electricity**—The components and connectors on modules are sensitive to static electricity. To minimize electrostatic damage, take the necessary anti-static precautions. Both chassis provide a grounding terminal, to which you can connect a wrist strap.
- **Empty Slots**—Except for performing initial chassis verification or troubleshooting, do not operate the chassis with empty slots. Always insert a filler panel or instrument module into empty slots. This is especially important for the slots on either side of an instrument module. This allows proper air flow and cooling, and provides EMI shielding for the chassis and installed components. Leaving slots empty can increase fan speed, raise ambient noise, overheat components, and shut down modules.
- **Hot Swap**—PXIe does not explicitly support hot swap for instrument modules. Keysight recommends fully powering down the chassis before installing or removing modules

Install application module drivers (if necessary)

Installed application modules typically require device drivers and control software. You do not need to install them to verify basic chassis or embedded controller operation; but should install them on the controller at this time. Consult the module provider for software requirements and instructions.

NOTE

Connect the embedded controller to the Internet to locate and install the necessary drivers.

Upgrading from the M9036A

If you already have a Keysight M9036A Embedded Controller and you are upgrading to an M9035A, be aware of the following:

- The GPIB cables are not compatible.
- The video output and cables are not compatible.
- The M9035A, unlike the M9036A and M9037A, does not have a Soft Front Panel or its own IVI drivers. The PXIe chassis driver provides the IVI KtMTrig driver to provide Trigger Manager functionality. The IVI KtMTrig driver can be found at:

C:\ProgramFiles\IVI Foundation\IVI\Drivers\KtMTrig

or

C:\ProgramFiles (x86)\IVI Foundation\IVI\Drivers\KtMTrig

Any programs/applications that have been written utilizing the M9036A drivers will have to be updated.

Controller Operating System

Your M9035A comes with the Microsoft Windows operating system pre-installed along with the latest version of Keysight's IO Libraries Suite. This section provides some general system configuration and preventative maintenance procedures that you, the customer, are responsible for. In general, the M9035A operates as any other PC, including remote desktop access.

The Windows operating system supplied with your M9035A is licensed for use on the hard drive mounted to the controller. If the hard drive is replaced, it may be your responsibility to purchase or relicense the operating system.

NOTE

The default Administrator password is **Keysight4u!**

Keysight recommends that you change the password.

M9018 PXIe Chassis PCIe Link Configuration

This discussion is applicable when using the M9035A in an M9018A or M9018B PXIe Chassis. It does not apply for use with the M9019A or M9010A PXIe chassis, because they have a fixed configuration of 1x8 and 1x16 for their PCIe Link fabric.

PCIe link configuration refers to how the PXIe chassis PCIe Switch Fabric is configured to connect PCI Express signals between slot 1, the system controller slot, and the other chassis slots. For a review of the supported PCIe link configurations, please refer to the *PXIe Chassis User Guide* (available from the Windows **Start** button, then look under Keysight).

For a detailed graphics, explaining the operation of the chassis PCIe data paths, see the *Keysight PXIe Chassis Interactive Block Diagram* at www.keysight.com/find/pxi-blockdiagram.

Keysight's M9035A embedded controller can boot and run with all of the PCIe switch fabric configurations supported by the M9018 chassis. The supported switch fabric configurations are:

- **1x8 Configuration** – Referred to as 1x8, this configuration provides one x8 link from the M9035A embedded controller to the PCIe switch fabric. While the 1x8 configuration will work with the M9035A, it is better suited for use with the M9021A system module which supports 8 PCIe lanes.
- **2x8 Configuration** - Referred to as 2x8, this configuration provides two x8 links from the M9035A embedded controller to the PCIe switch fabric. The two x8 links provide the highest performance I/O to the 18 chassis slots; therefore, the 2x8 configuration is recommended for use with the M9035A.

- **4x4 Configuration** – Referred to as 4x4, this configuration provides four x4 links from the M9035A embedded controller to the PCIe switch fabric. While the 4x4 configuration will work with the M9035A, it is more advantageous with certain non-Keysight system modules.

Use the **PCIe Switch Fabric Configurator** utility to change the PCIe Switch Fabric of the M9018A or M9018B.

The **PCIe Switch Fabric Configurator** utility is available from the Windows **Start** button, then look under Keysight. Instructions for using the **PCIe Switch Fabric Configurator** utility are provided in the *PXIe Chassis User Guide*.

M9035A Accessories

Accessory Number	Description
Y1206A	Keyboard and optical mouse
Y1260A	GPIB Cable*
Y1261A	Display Port to DVI adapter
Y1262A	DisplayPort cable
Y1263A	Display Port to VGA adapter
Y1267A	Spare SSD and upgrade COA with carrier Win 10 IoT Ent 2019 LTSC Value/64 bit/256GB
Y1267B	Spare SSD and upgrade COA with carrier Win 11 IoT Ent 2024 LTSC 24H2/64 bit/256GB
Y1213A	EMI Filler Panel Kit (5 single slot panels) -- for the PXIe chassis
Y1214A	Air Inlet Kit (one 3-slot, two 1-slot) -- for the PXIe chassis
Y1275A	Slot Blocker Kit (5 single slot blockers) -- for the PXIe chassis

* This is not the same GPIB cable used on the Keysight M9036A PXIe Embedded Controller, they are not compatible.

Environmental Operating Conditions

The Keysight M9035A PXIe Embedded Controller is designed to operate in a temperature range of 0 °C to +55 °C with non-condensing humidity. Maximum Relative Humidity (non-condensing): 95%RH up to 40 °C, decreases linearly to 45%RH at 55 °C*. The maximum operating altitude is 3048 m (10,000 ft). The module should be operated in an indoor environment where temperature and humidity are controlled. Condensation can pose a potential shock hazard.

Condensation can occur when the module is moved from a cold to a warm environment, or if the temperature and/or humidity of the environment change quickly.

Samples of this product have been type tested in accordance with the Keysight Environmental Test Manual and verified to be robust against the environmental stresses of storage, transportation and end-use. Those stresses include but are not limited to temperature, humidity, shock, vibration, altitude and power line conditions. For complete specifications, check the Keysight web site at: www.keysight.com/find/M9035A. Test methods are aligned with IEC 60068-2 and levels are similar to MIL-PRF-28800F Class 3.

* From 40 °C to 55 °C, the maximum% Relative Humidity follows the line of constant dew point



This information is subject to change
without notice
© Keysight Technologies, Inc.
2021-2025
Published in USA
Third Edition, February 2025



M9035-90001