

# Keysight 34945A Microwave Switch/Attenuator Driver Module

# Notices

## Copyright Notice

© Keysight Technologies 2011–2022

No part of this manual may be reproduced in any form or by any means (including electronic storage and retrieval or translation into a foreign language) without prior agreement and written consent from Keysight Technologies as governed by United States and international copyright laws.

## Trademarks

Microsoft® and Windows® are U.S. registered trademarks of Microsoft Corporation.

## Manual Part Number

34980-90045

## Edition

Edition 7, Aug 2022

## Printed in:

Printed in Malaysia

## Published by:

Keysight Technologies  
Bayan Lepas Free Industrial Zone,  
11900 Penang, Malaysia

## Technology Licenses

The hardware and/or software described in this document are furnished under a license and may be used or copied only in accordance with the terms of such license.

## Declaration of Conformity

Declarations of Conformity for this product and for other Keysight products may be downloaded from the Web. Go to <http://www.keysight.com/go/conformity>. You can then search by product number to find the latest Declaration of Conformity.

## U.S. Government Rights

The Software is “commercial computer software,” as defined by Federal Acquisition Regulation (“FAR”) 2.101. Pursuant to FAR 12.212 and 27.405-3 and Department of Defense FAR Supplement (“DFARS”) 227.7202, the U.S. government acquires commercial computer software under the same terms by which the software is customarily provided to the public. Accordingly, Keysight provides the Software to U.S. government customers under its standard commercial license, which is embodied in its End User License Agreement (EULA), a copy of which can be found at <http://www.keysight.com/find/sweula>. The license set forth in the EULA represents the exclusive authority by which the U.S. government may use, modify, distribute, or disclose the Software. The EULA and the license set forth therein, does not require or permit, among other things, that Keysight: (1) Furnish technical information related to commercial computer software or commercial computer software documentation that is not customarily provided to the public; or (2) Relinquish to, or otherwise provide, the government rights in excess of these rights customarily provided to the public to use, modify, reproduce, release, perform, display, or disclose commercial computer software or commercial computer software documentation. No additional government requirements beyond those set forth in the EULA shall apply, except to the extent that those terms, rights, or licenses are explicitly required from all providers of commercial computer software pursuant to the FAR and the DFARS and are set forth specifically in writing elsewhere in the EULA. Keysight shall be under no obligation to update, revise or otherwise modify the Software. With respect to any technical data as defined by FAR 2.101, pursuant to FAR 12.211 and 27.404.2 and DFARS 227.7102, the U.S. government acquires no greater than Limited Rights as defined in FAR 27.401 or DFAR 227.7103-5 (c), as applicable in any technical data.

## Warranty

THE MATERIAL CONTAINED IN THIS DOCUMENT IS PROVIDED “AS IS,” AND IS SUBJECT TO BEING CHANGED, WITHOUT NOTICE, IN FUTURE EDITIONS. FURTHER, TO THE MAXIMUM EXTENT PERMITTED BY APPLICABLE LAW, KEYSIGHT DISCLAIMS ALL WARRANTIES, EITHER EXPRESS OR IMPLIED, WITH REGARD TO THIS MANUAL AND ANY INFORMATION CONTAINED HEREIN, INCLUDING BUT NOT LIMITED TO THE IMPLIED WARRANTIES OF MERCHANTABILITY AND FITNESS FOR A PARTICULAR PURPOSE. KEYSIGHT SHALL NOT BE LIABLE FOR ERRORS OR FOR INCIDENTAL OR CONSEQUENTIAL DAMAGES IN CONNECTION WITH THE FURNISHING, USE, OR PERFORMANCE OF THIS DOCUMENT OR OF ANY INFORMATION CONTAINED HEREIN. SHOULD KEYSIGHT AND THE USER HAVE A SEPARATE WRITTEN AGREEMENT WITH WARRANTY TERMS COVERING THE MATERIAL IN THIS DOCUMENT THAT CONFLICT WITH THESE TERMS, THE WARRANTY TERMS IN THE SEPARATE AGREEMENT SHALL CONTROL.

## Safety Information

### CAUTION

A CAUTION notice denotes a hazard. It calls attention to an operating procedure, practice, or the like that, if not correctly performed or adhered to, could result in damage to the product or loss of important data. Do not proceed beyond a CAUTION notice until the indicated conditions are fully understood and met.

### WARNING















A WARNING notice denotes a hazard. It calls attention to an operating procedure, practice, or the like that, if not correctly performed or adhered to, could result in personal injury or death. Do not proceed beyond a WARNING notice until the indicated conditions are fully understood and met.

**NOTE**

This document contains references to Agilent. Please note that Agilent's Test and Measurement business has become Keysight Technologies. For more information, go to [www.keysight.com](http://www.keysight.com).

## Safety Symbols

The following symbols or markings that may be on or with the instrument and in the documentation indicate precautions which must be taken to maintain safe operation of the instrument.

	Alternating current (AC)		Frame or chassis (ground) terminal
	Standby supply. Unit is not completely disconnected from ac mains when switch is off		Caution, risk of electric shock
	Caution, risk of danger (refer to this manual for specific Warning or Caution information)		Direct current (DC)
	Off (mains supply)		On (mains supply)
	Three phase alternating current		Presence of a laser device
	Protective earth (ground) terminal		Equipment protected throughout by double insulation or reinforced insulation
	Caution, hot surface		Product is sensitive to electrostatic discharge

## Safety Considerations

Read the information below before using this instrument.

The following general safety precautions must be observed during all phases of operation, service, and repair of this instrument. Failure to comply with these precautions or with specific warnings elsewhere in this manual violates safety standards for design, manufacture, and intended use of the instrument. Keysight Technologies assumes no liability for the customer's failure to comply with these requirements.

---

**WARNING**

Refer to the 34980A User's Guide before using the equipment. The 34980A User's Guide contains additional important information about the modules.

---

**WARNING****GENERAL**

If this product is not used as specified in the operating instructions, the protection provided by the equipment could be impaired. This product must be used in a normal condition (in which all means for protection are intact) only. Any external connections must be made prior to applying power.

---

**WARNING****DO NOT REMOVE THE INSTRUMENT COVER**

No operator serviceable parts inside. Do not install substitute parts or perform any unauthorized modifications to the instrument. Return the instrument to Keysight for service and repair to ensure the safety features are maintained in operational condition. Instruments that appear damaged or defective should be made inoperative and secured against unintended operation until they can be repaired.

---

**WARNING****GROUND THE INSTRUMENT**

This is a Safety Protection Class I Product (provided with a protective earthing ground incorporated in the power cord). The mains plug shall only be inserted in a socket outlet provided with a protective earth contact. Any interruption of the protective conductor inside or outside of the product is likely to make the product dangerous. Intentional interruption is prohibited. The mains wiring and connectors shall be compatible with the connector used in the premise electrical system. Inadequate earth grounding can damage the instrument. Always use the three-prong AC power cord supplied with the instrument.

Connect the AC power cord as follow:

- Ensure that the power cord is not damaged.
  - Install the signal generator so that one of the following items is readily identifiable and easily reached by the operator: AC power cord, alternative switch or circuit breaker.
  - Insert the mains plug into a socket outlet provided with a protective earth grounding.
- 

**WARNING****IN CASE OF DAMAGE**

Do not use the instrument if it is damaged. Before you use the instrument inspect all connections. Pay particular attention to the insulation surrounding connectors and / or cable assembly insulation. NEVER use a cable showing any signs of damage. Faulty cables can cause electrical shock and /or fire hazards and could lead to personal injury or death.

---

**WARNING**

Refer to the User Guides of the 34980A and relevant modules before using the equipment.

---

**WARNING**

The detachable power cord is the instrument disconnecting device. It disconnects the mains circuits from the mains supply before other parts of the instrument. The front panel switch is only a standby switch and is not a LINE switch (disconnecting device). The instrument power cord does not disconnect or de-energize external circuits connected to the analog bus, terminal blocks or modules.

---

**WARNING**

Safety of any system incorporating the equipment is the responsibility of the assembler of the system.

---

**WARNING**

Keysight Customers utilizing the Open Platform Test Systems are classified as follows and require the user to have the appropriate skillset:

**Operator:** Interacts with the test system in a production environment, selection of test sequences, defining variables, running tests (test results, test statistics, control of marking devices)

**Supervisor:** Includes access to maintenance functions and utility sequences (control of hardline system functions, access to test area)

**Developer:** Full access

---

**WARNING**

Dangerous voltage levels capable of causing death, may be present on a channel. Use extreme caution when handling and testing and adjusting this instrument. Any voltages greater than 30 Vrms, 42.4 Vpeak and 60 Vdc are considered hazardous (IEC 61010-1).

---

**WARNING**

Removal of the instrument's cover is to be conducted by qualified personnel only. Only qualified, trained personnel who are aware of the hazards involved should remove instrument covers. Prevent operators from accessing any external circuits, test fixtures, cables or wherever hazardous voltages may be present. Failure to recognize and observe normal safety precautions could result in personal injury or death.

---

**WARNING**

**ENVIRONMENTAL HEALTH & SAFETY:** When any channel is connected to a hazardous voltage source, the instrument and the device under test should be supervised, following local EHS practices to restrict access.

---

## Environmental Conditions







Keysight 34980A is designed for indoor use in an installation category II and low condensation environment. Table below shows the general environmental conditions for this instrument. Refer to the product data sheet at <https://literature.cdn.keysight.com/litweb/pdf/5989-1437EN.pdf> for more information on the instrument general specifications.

General specifications	Requirement
<b>Temperature</b>	Operating condition: 0°C to 55°C Storage condition: -40°C to 70°C
<b>Humidity</b>	Maximum Relative Humidity (non-condensing): 80% RH up to 40°C, decreases linearly to 37% RH at 55°C <sup>[a]</sup>
<b>Altitude</b>	Up to 2,000 m
<b>Pollution degree</b>	1 or 2

[a] From 40°C to 55°C, the maximum % Relative Humidity follows the line of constant dew point.

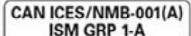

## Regulatory Markings

	<p>The CE mark is a registered trademark of the European Community. This CE mark shows that the product complies with all the relevant European Legal Directives.</p>		<p>The UK conformity mark is a UK government owned mark. Products showing this mark comply with all applicable UK regulations.</p>	<p><b>CAN ICES/NMB-001(A)</b></p> <p>This indicates that this ISM device complies with the Canadian ICES-001. Interference-Causing Equipment Standard for industrial, scientific and medical (ISM) equipment. Matériel industriel, scientifique et médical (ISM)</p>	 <p>The Keysight email address is required by EU directives applicable to our product.</p>	 <p>The CE mark is a registered trademark of the European Community. This CE mark shows that the product complies with all the relevant European Legal Directives.</p> <p>ICES/NMB-001 indicates that this ISM device complies with the Canadian ICES-001.</p> <p>Cet appareil ISM est conforme à la norme NMB-001 du Canada.</p> <p>ISM GRP:1 Class A indicates that this is an Industrial Scientific and Medical Group 1 Class A product.</p>	<p><b>ISM 1-A</b></p> <p>This is a symbol of an Industrial Scientific and Medical Group 1 Class A product. (CISPR 11, Clause 5)</p>  <p>This is a combined marking to indicate product compliance with the Industry Canadian Interference-Causing Equipment Standard (ICES/NMB-001). This is also a symbol of an Industrial Scientific and Medical Group 1 Class A product (CISPR 11, Clause 5).</p>	 <p>This symbol is a South Korean Class A EMC Declaration. This is a Class A instrument suitable for professional use and in electromagnetic environment outside of the home.</p>	 <p>The RCM mark is a registered trademark of the Australian Communications and Media Authority.</p>
---	---	---	--	--	---	--	---	--	---



This symbol indicates the time period during which no hazardous or toxic substance elements are expected to leak or deteriorate during normal use. Forty years is the expected useful life of the product.



This instrument complies with the WEEE Directive (2002/96/EC) marking requirement. This affixed product label indicates that you must not discard this electrical or electronic product in domestic household waste.



Universal recycling symbol.

**IP x y**

This mark indicates product has been designed to meet the requirements of "IP x y", where "x" is the solid particle protection and "y" is the liquid ingress protection.

## Waste Electrical and Electronic Equipment (WEEE) Directive 2002/96/EC

The crossed out wheeled bin symbol indicates that separate collection for waste electric and electronic equipment (WEEE) is required, as obligated by the EU DIRECTIVE and other National legislation.

Please refer to [keysight.com/go/takeback](https://www.keysight.com/go/takeback) to understand your Trade in options with Keysight in addition to product takeback instructions.



## Sales and Technical Support

To contact Keysight for sales and technical support, refer to the support links on the following Keysight websites:

- [www.keysight.com/find/34980a](https://www.keysight.com/find/34980a)  
(product-specific information and support, software and documentation updates)
- [www.keysight.com/find/assist](https://www.keysight.com/find/assist)  
(worldwide contact information for repair and service)

THIS PAGE HAS BEEN INTENTIONALLY LEFT BLANK.

# Table of Contents

Safety Symbols	3
Safety Considerations	4
Environmental Conditions	8
Regulatory Markings	9
Waste Electrical and Electronic Equipment (WEEE) Directive 2002/96/EC	11
Sales and Technical Support	11
<b>1 About the Instrument</b>	
34945A Use Model	24
Equipment Inventory	25
Materials Included	25
Input Power and Operating Environment	26
Recommended Accessories	27
Y1157A - Y1159A Cable Assembly	30
Y1157A Cable Kit Assembly	30
Y1158A Cable Kit Assembly	33
Y1159A Cable Kit Assembly	36
<b>2 Hardware Configuration</b>	
Network Configuration	40
Selecting a LAN Network	40
Instrument Configuration	41
The 34945EXT Module	44
Channel Numbering	46
Internal/External Power Supply Considerations	49
Keysight Switch/Attenuator Configuration	51
Keysight N1810 / N1811 / N1812 Series Coaxial Switches	51
Keysight 87104/87106/87406 - L7104/L7106/L7204/L7206 Coaxial Switches	53

Keysight 87204 / 87206/ 87606 Series Coaxial Switches	55
Keysight 8767/8/9M Microwave Single-Pole Multi-Throw Switches	57
Keysight 84904/6/7 K/L and 84904/5/8M Programmable Step Attenuators	59
Keysight 8494 /5/ 6/ 7 Programmable Step Attenuators	61
Keysight 849xG/H/K Programmable Step Attenuators Option 016	62
Keysight 87222 and L7222 Coaxial Switches	64
Keysight 8762 / 8763 / 8764 Series Coaxial Switches	66
Keysight 8765 Series Coaxial Switches	68
Keysight 8766/7/8/9K Microwave Single-Pole Multi-Throw Switches	70
Keysight U9397A / U9397C FET Solid State Switches	72
<b>3 Software Installation and Configuration</b>	
Software Requirements	76
Installing the Keysight IO Libraries	77
Installing Instrument Drivers	79
Adding Instruments to the Interface	80
Configuring the LAN Interface	80
LAN Default Configuration	85
Configuring the GPIB Interface	85
Configuring the USB Interface	88
The Web-Enabled Instrument Interface and Interactive IO	91
Using Interactive IO	91
Firmware and Driver Updates	93
Downloading and Installing the Update Utility	93
Downloading the Firmware Update	93
Installing the Firmware Update	94
Downloading IVI-COM Driver and LabVIEW Driver Updates	97
<b>4 Introduction to Programming</b>	
Getting Started with the 34945A Web-Enabled Interface	101
Connecting to the Instrument and Viewing its Home Page	101
An Overview of the 'Browser Web Control' Page	102

Switch/Attenuator Channel Configuration Window	105
SCPI Command Interface	108
Logging SCPI Commands	109
System Verification	111
Switch and Attenuator Programming	116
Keysight N1810/N1811/N1812 Series Switches	116
Keysight 87104/87106/87406 - L7104/L7106/L7204/L7206 Switches	119
Keysight 87204 / 87206 Series and 87606 Switches	121
Keysight 8490x Series / 849x Series Attenuators and 876xM Series Switches	123
Keysight 87222 Series and L7222C Switches	126
Keysight 876x Series and U9397A/C Switches	129
Sequence Programming	132
Power-On, *RST, and SYSTem:CPON States	134
Restoring 34945A Factory Settings	135

## 5 Additional Operating Information

34945A SCPI Command Summary	138
Y1150A - Y1155A Switch Control Tables	144
Y1150A Switch Control	144
Y1151A Switch Control	145
Y1152A Switch Control	146
Y1153A Switch Control	147
Y1154A Switch Control	148
Y1155A Switch Control	149
Drive Modes	152
Using Single-Coil Switches and Attenuators	153
Continuous Drive Mode	153
Single Coil with Separate Position Indicators Connection Diagram	154
Using Dual-Coil Switches and Attenuators	156
Pairing Channels	156
Paired Drive With Separate Position Indicators	157

Paired Drive With Combined Position Indicators	159
Pulsed Actuation Mode	161
Overcurrent Conditions	163
Overcurrent Conditions with External Supplies	164
Command Execution Times	164
Verifying Switch States	165
LED Drive Indicators	167



## List of Figures

Figure 1-1	Distribution Board Socket and Y1157A Cable Connector Orientation. . . . .	31
Figure 1-2	Y1157A Connector Orientation and Ribbon Cable Routing. . . . .	32
Figure 1-3	Distribution Board Socket and Y1158A Cable Connector Orientation. . . . .	33
Figure 1-4	Y1158A 10-pin to 10-pin Connector Orientation and Cable Routing. . . . .	34
Figure 1-5	Y1158A 14-pin to 10-pin Connector Orientation and Cable Routing. . . . .	35
Figure 1-6	Distribution Board Socket and Y1159A Cable Connector Orientation. . . . .	37
Figure 1-7	Y1159A 16-pin to 16-pin Connector Orientation and Cable Routing. . . . .	38
Figure 2-1	34945A Microwave Switch/Attenuator Driver Configuration. . . . .	42
Figure 2-2	The 34945EXT Module and Y1150A-Y1155A Distribution Boards. . . . .	45
Figure 2-3	Keysight N1810 / N1811 / N1812 Pin Definition and Orientation. . . . .	52
Figure 2-4	Keysight 871x / 874x / L71x / L72x Pin Definition and Orientation. . . . .	54
Figure 2-5	Keysight 87204 / 87206 / 87606 Pin Definition and Orientation. . . . .	56
Figure 2-6	Keysight 8767/8/9M Port Definitions and Connections. . . . .	58
Figure 2-7	Keysight 84904/6/7 K/L Attenuator Pin Definitions and Connections. . . . .	60
Figure 2-8	Keysight 8494/5/ 6/7 Attenuator Pin Definitions and Connections. . . . .	61
Figure 2-9	Keysight 8494/5/6/7 Opt. 016 Att. Pin Definitions and Connections. . . . .	63
Figure 2-10	Keysight 87222 / L7222 Pin Definition and Orientation. . . . .	65

Figure 2-11	Keysight 8762 / 8763 / 8764 Terminal Connections. . . . .	67
Figure 2-12	Keysight 8765 Terminal Connections. . . . .	69
Figure 2-13	Keysight 8766/7/8/9K Section Definitions and Connections. . . . .	71
Figure 2-14	Keysight U9397A / U9397C Connector Definitions and Connections. . . . .	72
Figure 3-1	Starting Connection Expert. . . . .	80
Figure 3-2	Keysight Connection Expert (ACE) Opening Window. . . . .	81
Figure 3-3	Keysight Connection Expert “Add Instrument” Window. 82	82
Figure 3-4	Instruments Found on a Local Subnet. . . . .	83
Figure 3-5	Adding Instruments to the GPIB Interface. . . . .	86
Figure 3-6	The 34980A (34945A) Added to the USB Interface. . . . .	89
Figure 3-7	Adding a VISA Alias for the 34980A. . . . .	90
Figure 3-8	Selecting an Instrument and Starting Interactive IO. . . . .	92
Figure 3-9	Firmware Update Utility File Selection Window. . . . .	94
Figure 3-10	Specifying the Instrument Address. . . . .	95
Figure 4-1	The 34980 (34945A) Programming Home Page. . . . .	100
Figure 4-2	34945EXT, Distribution Board, and Channel Configuration. . . . .	103
Figure 4-3	The Remote Module Configuration Window. . . . .	104
Figure 4-4	The Switch/Attenuator Channel Configuration Window. 105	105
Figure 4-5	The Bank (Distribution Board) Configuration Window. . . . .	106
Figure 4-6	Sending Commands from the SCPI Command Interface. 108	108
Figure 4-7	Logging SCPI Commands within the System Overview Window. . . . .	109
Figure 4-8	Running the Y1156A Verification Sequence. . . . .	113
Figure 4-9	Using the Y1156A for Position Indicator Verification. . . . .	115
Figure 4-10	Y1150A Distribution Board Web User Interface Preset State. . . . .	118
Figure 4-11	Y1151A Distribution Board Web User Interface Preset State. . . . .	120
Figure 4-12	Y1152A Distribution Board Web User Interface Preset State. . . . .	122

Figure 4-13	Y1153A Distribution Board Web User Interface Preset State. . . . .	125
Figure 4-14	Y1154A Distribution Board Web User Interface Preset State. . . . .	128
Figure 4-15	Y1155A Distribution Board Web User Interface Preset State. . . . .	131
Figure 4-16	Defining Programming Sequences with the Sequences Window. . . . .	133
Figure 5-1	TTL and Open Collector Drive Modes. . . . .	152
Figure 5-2	Continuous Drive Signals. . . . .	153
Figure 5-3	Single-Coil Switch Connection Diagram (separate position indicators). . . . .	155
Figure 5-4	Dual-Coil Switch Connection Diagram (separate position indicators). . . . .	158
Figure 5-5	Dual-Coil Switch Connection Diagram (combined position indicators). . . . .	160
Figure 5-6	Pulse Actuation Mode Diagram. . . . .	161
Figure 5-7	Actuation Pulse Duty Cycle: Pulse Width + Recovery Time. . . . .	163

THIS PAGE HAS BEEN INTENTIONALLY LEFT BLANK.

## List of Tables

Table 1-1	34980A/34945A Instrument Input Power Specifications.	26
Table 1-2	Recommended Accessories for Keysight Switches/ Attenuators. . . . .	27
Table 3-1	34945A Development Environments and Drivers. . . . .	76
Table 3-2	Keysight IO Libraries Suite System Requirements. . . . .	78
Table 3-3	Default LAN Configuration Settings. . . . .	85
Table 4-1	34945A Factory Settings. . . . .	135
Table 5-1	34945A SCPI Command Summary. . . . .	138

THIS PAGE HAS BEEN INTENTIONALLY LEFT BLANK.

# 1 About the Instrument

34945A Use Model	24
Equipment Inventory	25
Input Power and Operating Environment	26
Recommended Accessories	27
Y1157A - Y1159A Cable Assembly	30

Welcome. This manual contains component, configuration, and programming information for the Keysight 34945A Microwave Switch/Attenuator Driver.

The 34945A controls and monitors RF/microwave switches and attenuators used in applications such as wireless communications, avionics, medical electronics, and in test and measurement systems. The 34945A is optimized for use with the Keysight family of RF/microwave switches and attenuators.

The 34945A is a one slot plug-in module used with the Keysight 34980A Multifunction Switch/Measure Unit.

Prior to using the 34945A, refer to this chapter for specific information on:

- the use model for the 34945A product and documentation
- materials (cables, hardware, software) supplied with the 34945A
- input power and operating/storage specifications
- supported Keysight RF/microwave switches and attenuators
- distribution boards and brackets required for using the switches and attenuators in the RF switch platforms
- Y1157A - Y1159A control cable assembly instructions

## 34945A Use Model

The use model for the 34945A microwave switch/attenuator driver module and for this manual is:

- 1** Inventory and identification of standard 34945A components and recommended switch/attenuator accessories (**Chapter 1**).
- 2** Assembling control cables used between the switches/attenuators and the Y1150A - Y1155A distribution boards (**Chapter 1**).
- 3** Wiring the switches/attenuators to the distribution boards and installing the distribution boards on the 34945EXT module (**Chapter 2**).
- 4** Configuring the system software in preparation of switch/attenuator configuration and control. Applying power to the 34980A/34845A (**Chapter 3**).
- 5** Programming (configuration and control) of the switches and attenuators (**Chapter 4**).

Reference information for selected topics in chapters 1–4 is located in **Chapter 5**. Detailed information on the 34945A command set, as well as an on-line copy of this manual, instrument drivers, application notes, and computer-aided design (CAD) models for building RF cables can be found at [www.keysight.com/find/34980A](http://www.keysight.com/find/34980A).

When using this manual, note that chapters 2 and 4 are organized by switch and attenuator model and the same sequence is found throughout the chapters.



## Equipment Inventory

The first step prior to using the 34945A for switch and attenuator control is to verify that all materials and accessories required for a given switch or attenuator model are available. This section lists the materials that ship standard with each 34945A instrument.

### Materials Included

The following materials are included with the 34945A:

- 1** +24V 9-pin D-Sub extension cable (8121-1289)
  - used between the L4445A and the primary 34945EXT module
- 2** 34945EXT extender module
  - added automatically to each 34945A ordered
  - includes CAT-5 cable (p/n 8121-1339)
  - used between multiple 34945EXTs

## Input Power and Operating Environment

The input power, operating environment, and storage environment specifications for the 34945A are listed in Table 1-1. Refer to the instrument data sheet for a complete listing of specifications. The data sheets can be found on the Web at: [www.Keysight.com/find/34980A](http://www.Keysight.com/find/34980A)

**Table 1-1** 34980A/34945A Instrument Input Power Specifications.

	Description
Power Supply and Line Frequency:	Universal 100 - 240V $\pm 10\%$ 50-60 Hz $\pm 10\%$ auto sensing
Power Consumption:	150 VA
Operating Environment:	Full accuracy for 0°C to 55°C Full accuracy to 80% R.H. (non-condensing) at 40°C and decreases linearly to 37% RH at 55C
Storage Environment:	-40°C to 70°C

The 34980A/34945A should be operated in an indoor environment where temperature and humidity are controlled. Condensation can pose a potential shock hazard. Condensation can occur when the modules are moved from a cold to a warm environment, or if the temperature and/or humidity of the environment changes quickly.

## Recommended Accessories

Switches and attenuators interface to the 34945A through distribution boards. The Y1150A - Y1155A distribution boards are ordered separately based on the switches/attenuators used in your application. Similarly, the recommended cables are available in the Y1157A - Y1159A cable kits. Like the distribution boards, the cable kits must be ordered separately.

Table 1-2 lists some of the common Keysight switches/attenuators and the distribution boards and cable kits they require. **Review Table 1-2 carefully to ensure that you have the appropriate accessories for your switches and attenuators. This will save you time and frustration!**

**Table 1-2** Recommended Accessories for Keysight Switches/Attenuators.

Switch Model	Reference Document Number <sup>(1)</sup>	Coil Voltage Option	Position Indicator Option	DC Connector Option	Distribution Board [number of switches per board]	Cable Kit <sup>(3)</sup>
N1810UL N1810TL N1811TL N1812UL	5968-9653E	124	402/403 <sup>(2)</sup>	201 (DB9F)	Y1150A [8] Y1152A [2] Y1154A [6]	Y1157A
87104A - C 87106A - C	5091-3366E	024	standard	161 (16-pin DIP)	Y1151A [2]	Y1159A
87406B	5965-7841E					
87204A - C 87206A - C	5965-3309E	standard	standard	161 (16-pin DIP)	Y1152A [1]	Y1159A
87606B	5965-7842E					
87222C - E	5968-2216E	standard	standard	161 (10-pin DIP)	Y1154A [2]	Y1158A
L7104A - C L7106A - C	5989-6030EN	024	standard	161 (16-pin DIP)	Y1151A [2]	Y1159A
L7204A - C L7206A - C						

**Table 1-2** Recommended Accessories for Keysight Switches/Attenuators. (continued)

Switch Model	Reference Document Number <sup>(1)</sup>	Coil Voltage Option	Position Indicator Option	DC Connector Option	Distribution Board [number of switches per board]	Cable Kit <sup>(3)</sup>
L7222C	5989-6084EN	standard	standard	161 (10-pin DIP)	Y1154A [2]	Y1158A
8762A - C 8763A - C 8764A - C	5952-1873E	024	n/a	solder terminals (standard)	Y1155A [8]	n/a
8762F	5964-3704E					
8765A - D 8765F	5952-2231E 5091-2679E	324	n/a	solder terminals (with 324)	Y1155A [8]	n/a
8766K - 7K 8768K - 9K	5959-7831	024	n/a	060 (12-pin Viking)	Y1155A [2] Y1155A [1]	n/a
8767M - 9M	5988-2477EN	024	n/a	10-pin DIP	Y1153A [2]	Y1158A
U9397A,C	5989-6088EN	standard	n/a	solder terminals	Y1155A [8]	n/a
84904K - L 84906K - L 84907K - L	5963-6944E	24V (standard)	standard	10-pin DIP (standard)	Y1153A [2]	Y1158A
84904M 84905M 84908M	5988-2475EN	024	standard	10-pin DIP (standard)	Y1153A [2]	Y1158A

**Table 1-2** Recommended Accessories for Keysight Switches/Attenuators. (continued)

Switch Model	Reference Document Number <sup>(1)</sup>	Coil Voltage Option	Position Indicator Option	DC Connector Option	Distribution Board [number of switches per board]	Cable Kit <sup>(3)</sup>
8494G - H 8495G - H 8496G - H	(4)	24V (standard)	standard	12-pin Viking (standard)	Y1153A [2]	n/a
8495K 8497K						

(1) For product and technical overviews, go to <http://www.Keysight.com/find/accessories>, select 'RF & Microwave Test Accessories'. Additional information can also be found in the "RF and Microwave Test Accessories Catalog" accessible from this site.

(2) Starting in June 2010, the current interrupt function (formerly Option 403) is a standard feature for these switches. The serial number information below shows which switch units have the current interrupt function included as standard.  
 N1810UL: Serial numbers MY07244672 and later  
 N1810TL: Serial numbers MY07247927 and later  
 N1811TL: Serial numbers MY07244660 and later  
 N1812UL: Serial numbers MY07240668 and later

(3) These cables must be assembled to their connectors. Cable assembly instructions are provided in this chapter.

(4) Information on these attenuators plus additional information on the other attenuators can be found in the "RF and Microwave Test Accessories Catalog" accessible from this site.

## Y1157A - Y1159A Cable Assembly

Three cable kits are available for connecting switches and attenuators to the Y115xA distribution boards:

Y1157A

Y1158A

Y1159A

The cable kits used with each switch/attenuator and distribution board are identified in Table 1-2.

### Y1157A Cable Kit Assembly

The Y1157A is a 10-pin ribbon connector to 9-pin D-Sub cable kit. The kit contains materials to build four cables and is used with the following distribution boards:

- Y1150A
- Y1152A
- Y1154A

The switches used with the Y1150A, Y1152A, and Y1154A which can also use the Y1157A cable are identified in Table 1-2.

The key to building the cables correctly is to understand the orientation of the socket pins on the distribution boards and the pin number orientation of the cable connectors. This orientation is shown in Figure 1-1. When using the D-sub connector, always refer to the pin orientation shown in the figure. Do not use the pin numbers printed on the part.

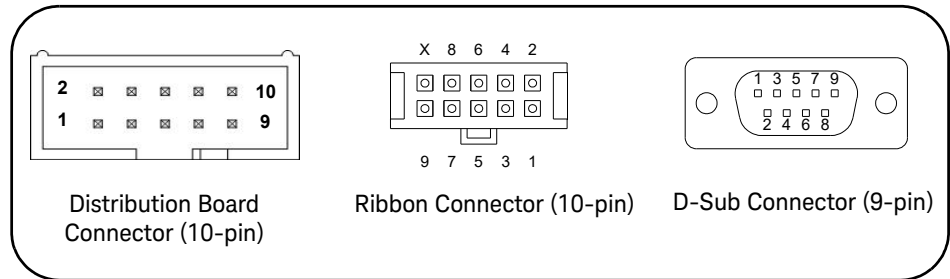

**Figure 1-1** Distribution Board Socket and Y1157A Cable Connector Orientation.

The steps for building the cables are as follows:

- 1 Cut the ribbon cable slightly longer than the desired length.
- 2 Position the D-Sub connector and the ribbon cable connector as shown in Figure 1-2. Route the cable **through** the connectors, noting the location of cable pin 1. By convention, pin 1 is indicated in red (the dark line in the drawing).

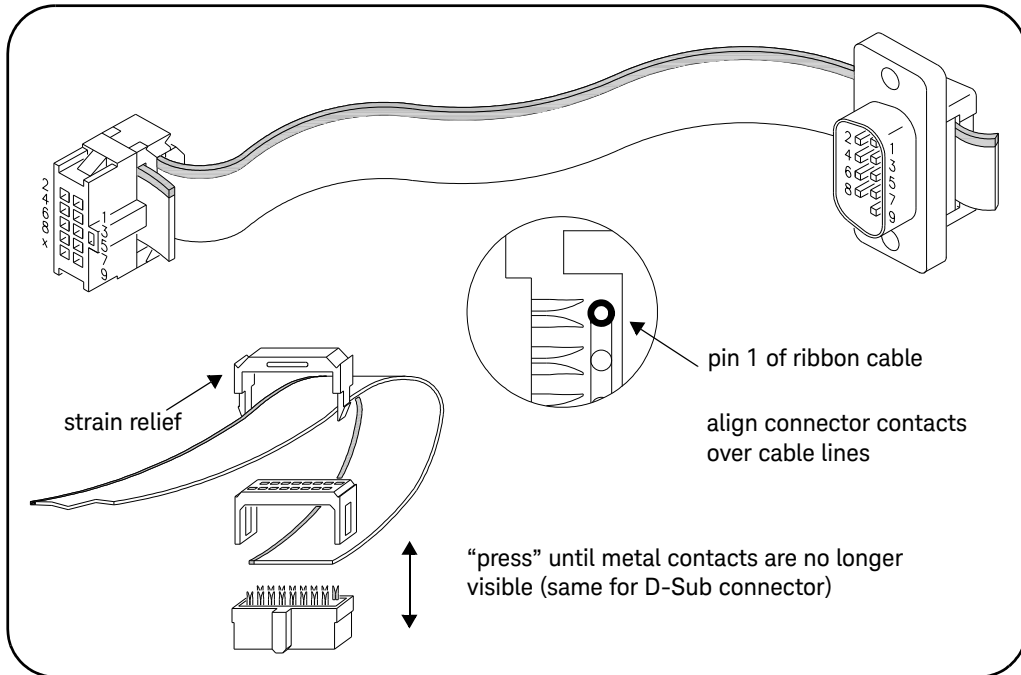

**Figure 1-2** Y1157A Connector Orientation and Ribbon Cable Routing.

- 3** Move the connectors to the ends of the cable, allowing for some overlap on the D-Sub connector end and strain relief on the ribbon cable connector end.  
**Note the orientation of the connectors and cable in the figure.**
- 4** Align the metal contacts of the ribbon connector over cable pin 1 (Figure 1-2) and the other pins, press the ribbon cable connector onto the cable using a vise or clamp to press the contacts **evenly** through the cable insulation. Continue to press the connector until the metal contacts are no longer visible.
- 5** Fasten the strain relief clamp over the cable and into the ribbon cable connector as shown in Figure 1-2. Remove any excess cable after the clamp is in place.
- 6** Align the metal contacts of the D-Sub connector over cable pin 1 and the other pins, press the D-Sub connector onto the cable using a vise or clamp to press the contacts **evenly** through the cable insulation. Continue to press the connector until the metal contacts are no longer visible. Remove any excess cable after the connector is in place.



## Y1158A Cable Kit Assembly

The Y1158A is a 10-pin to 10-pin and 14-pin to 10-pin ribbon connector cable kit. The Y1158A kit contains materials to build two cables of either type or one of each and is used with the following distribution boards:

- Y1153A (10-pin to 10-pin cable)
- Y1154A (14-pin to 10-pin cable)

The switches used with the Y1153A and Y1154A which can also use the Y1158A cable are identified in Table 1-2.

The key to building the cables correctly is to understand the orientation of the socket pins on the distribution boards and the pin number orientation of the cable connectors. This orientation is shown in Figure 1-3.

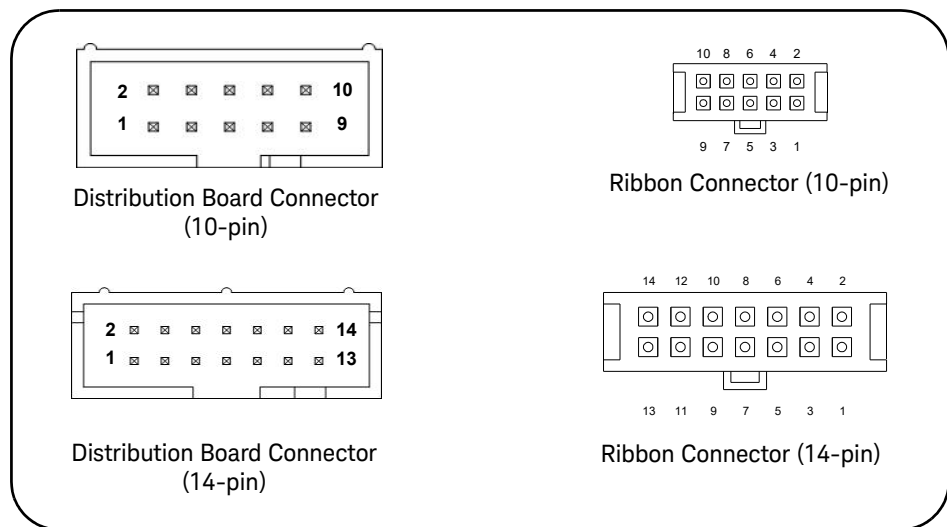
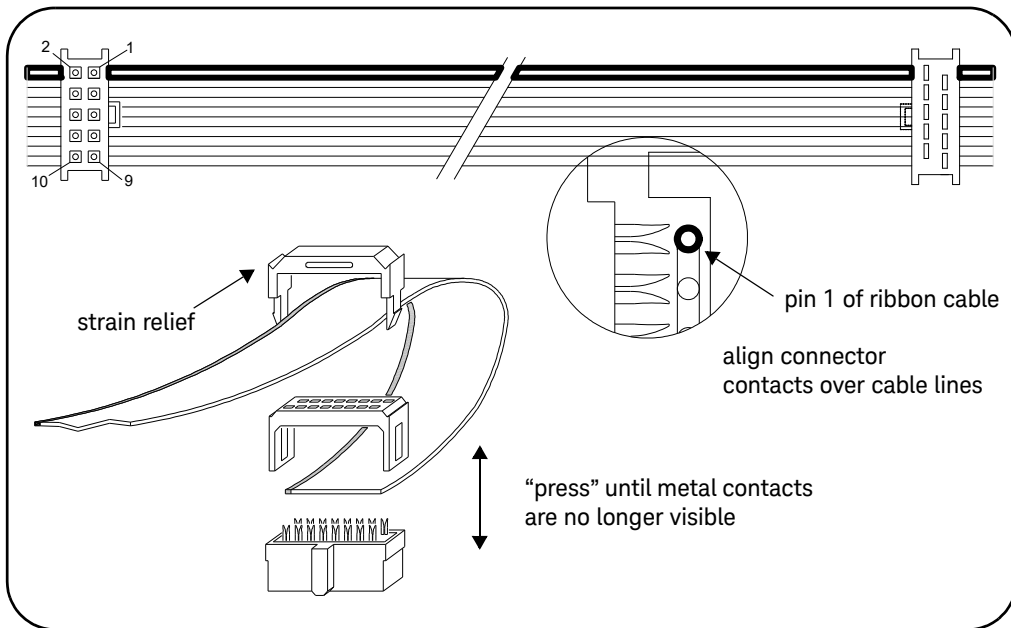

**Figure 1-3** Distribution Board Socket and Y1158A Cable Connector Orientation.

The steps for building the cables are as follows:

### 10-pin to 10-pin Cable

- 1 Cut the ribbon cable slightly longer than the desired length to allow for strain relief.
- 2 Position the ribbon cable connectors as shown in Figure 1-4. Route the cable **through** the connectors, noting the location of pin 1 on the cable. By convention, pin 1 is indicated in red (the dark line in the drawing).



**Figure 1-4** Y1158A 10-pin to 10-pin Connector Orientation and Cable Routing.

- 3 Move the connectors towards the ends of the cable, with some overlap for strain relief. **Note the orientation of the connectors and cable in the figure.**

- 4 Align the metal contacts of the ribbon connector over cable pin 1 and the other pins, press the ribbon cable connector onto the cable using a vise or clamp to press the contacts **evenly** through the cable insulation. Continue to press the connector until the metal contacts are no longer visible.
- 5 Repeat Step 4 for the other connector.
- 6 Fasten the strain relief clamps over the cable and into the ribbon cable connectors as shown in Figure 1-4. Remove any excess cable after the clamps are in place.

### 14-pin to 10-pin Cable

- 1 Cut the ribbon cable slightly longer than the desired length to allow for strain relief.
- 2 Position the ribbon cable connectors as shown in Figure 1-5. Route the cable **through** the connectors, noting the location of pin 1 on the cable. By convention, pin 1 is indicated in red (the dark line in the drawing).

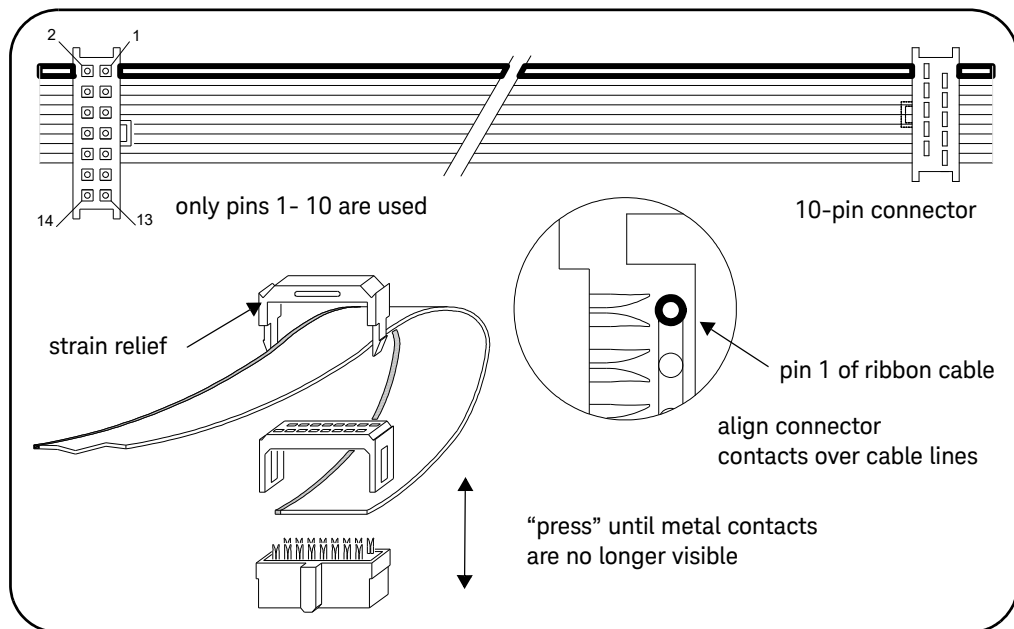

**Figure 1-5** Y1158A 14-pin to 10-pin Connector Orientation and Cable Routing.

- 3** Move the connectors towards the ends of the cable, with some overlap for strain relief. **Note the orientation of the connectors and cable in the figure.**
- 4** Align the metal contacts of the 14-pin ribbon connector over cable pins 1 through 10. The 14-pin connector will only make contact with pins 1 through 10. Press the ribbon cable connector onto the cable using a vise or clamp to press the contacts **evenly** through the cable insulation. Continue to press the connector until the metal contacts are no longer visible.
- 5** Repeat Step 4 for the 10-pin to 10-pin connector, noting the location of pin 1 on the cable.
- 6** Fasten the strain relief clamps over the cable and into the ribbon cable connectors as shown in Figure 1-5. Remove any excess cable after the clamps are in place.

## Y1159A Cable Kit Assembly

The Y1159A is a 16-pin to 16-pin ribbon connector cable kit. The Y1159A kit contains materials to build two cables and is used with the following distribution boards:

- Y1150A (LED position indicators)
- Y1151A (87104/87106/87406 and LED position indicators)
- Y1152A (87204/87206/87606 and LED position indicators)
- Y1153A (LED position indicators)
- Y1154A (LED position indicators)
- Y1155A (LED position indicators)

When connected to the LED1 or LED2 socket, the Y1159A cable allows you route the states of up to eight coils to LEDs mounted on a control panel. The Y1159A kit is also used with the Y1151A and Y1152A distribution boards for support of the switches listed above.

The key to building the cables correctly is to understand the orientation of the socket pins on the distribution boards and the pin number orientation of the cable connectors. This orientation is shown in Figure 1-6.

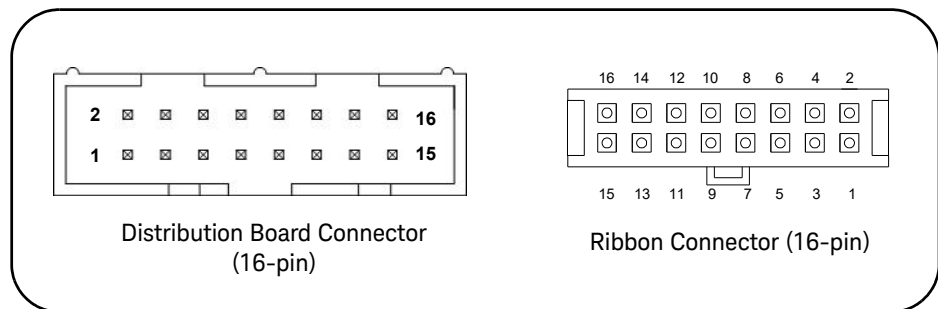

**Figure 1-6** Distribution Board Socket and Y1159A Cable Connector Orientation.

The steps for building the cables are as follows:

- 1** Cut the ribbon cable slightly longer than the desired length to allow for strain relief.
- 2** Position the ribbon cable connectors as shown in Figure 1-7. Route the cable **through** the connectors, noting the location of pin 1 on the cable. By convention, pin 1 is indicated in red (the dark line in the drawing).

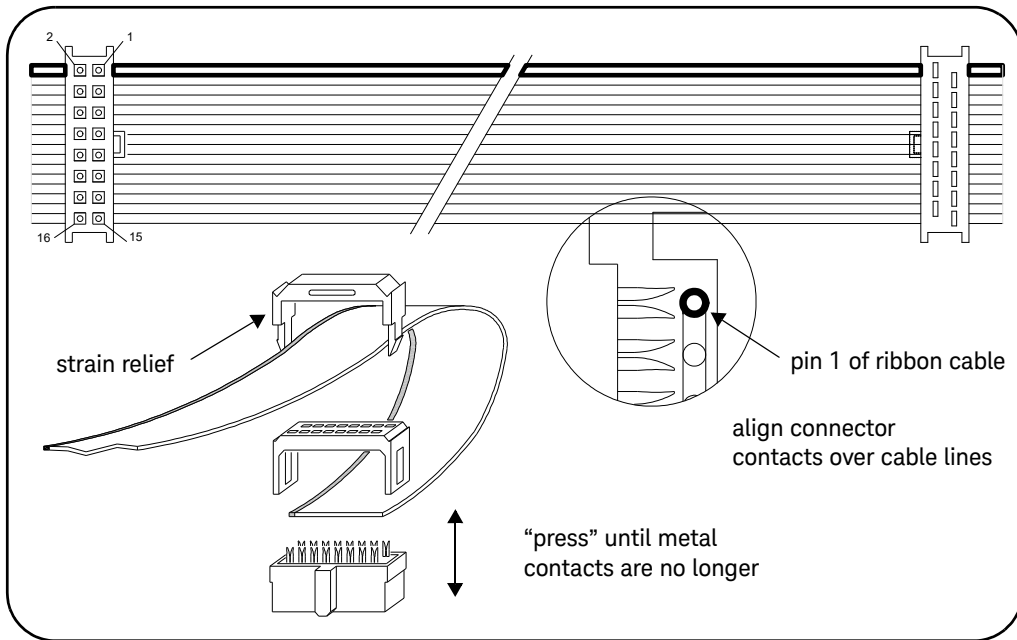

**Figure 1-7** Y1159A 16-pin to 16-pin Connector Orientation and Cable Routing.

- 3** Move the connectors towards the ends of the cable, with some overlap for strain relief. **Note the orientation of the connectors and cable in the figure.**
- 4** Align the metal contacts of the ribbon connector over cable pin 1 and the other pins, press the ribbon cable connector onto the cable using a vise or clamp to press the contacts **evenly** through the cable insulation. Continue to press the connector until the metal contacts are no longer visible.
- 5** Repeat Step 4 for the other connector.
- 6** Fasten the strain relief clamps over the cable and into the ribbon cable connectors as shown in Figure 1-7. Remove any excess cable after the clamps are in place.

## 2 Hardware Configuration

Network Configuration	40
Instrument Configuration	41
Keysight Switch/Attenuator Configuration	51

This chapter contains network, cabling, channel configuration, and switch wiring information for the 34945A Microwave Switch/Attenuator Driver and supported switches/attenuators.

Refer to this chapter for specific information on:

- choosing between a private LAN and site LAN network
- interconnections between the PC, 34945A, and 34945EXT extender
- channel numbering and pairing
- internal/external power supply considerations
- connecting switches and attenuators to the distribution boards

## Network Configuration

This section contains information for choosing a network configuration (a private or site LAN) in which to use the 34945A.

### Selecting a LAN Network

For the purposes of this manual, a private (isolated) LAN network is defined as a network configuration in which instrument access is a direct connection between the computer and the instrument, or to multiple instruments connected via a *dedicated* router or switch. A site (company-wide) LAN is defined as a network in which instrument access is available to many users at on-site and remote locations.

The instrument's application and/or your company's IT (Information Technology) department may have guidelines that help decide the type of network (private or site) used. If a network configuration has not been determined, refer to the following considerations concerning each type.

#### Private LAN Considerations

Among the basic parameters of a private LAN network to consider are security, performance, reliability, and IP address availability.

**Security:** a private network generally involves a direct connection between the PC and the instrument, or to multiple instruments using switches or routers. Access to the instrument is limited to users on the private network, as opposed to users on a site network that could locate and access the instrument from any location. Private networks can reduce the possibility of tests being disrupted by unplanned or unauthorized access. Code generation for test systems on a private network is often simplified as provisions against unauthorized users may not be required.

**Performance:** test systems where large amounts of data are transferred usually have faster throughput on a private network. On a site network, heavy and unpredictable LAN traffic affects each instrument (node) on the network. The impact on a test system is that repeatability is difficult to achieve as latencies are difficult to account for.



**Reliability:** private networks are fundamentally more reliable than site networks as they host fewer users and are less complex than site networks. Private networks are isolated from conditions that could bring down (crash) a site network.

**IP Address Availability:** Every instrument (node) on a LAN (private or site) has an IP (Internet Protocol) address. Due to the expanding use of the internet, the number of site network IP addresses available is limited. By using a router with Dynamic Host Configuration Protocol (DHCP) capability on a private network, the router can assign an IP address to each instrument thus creating a sub-network (subnet) that does not consume site IP addresses.

### Site LAN Considerations

For applications requiring access by many users or by users at distributed sites, a site LAN network is required. In addition to supporting multiple users, site LANs often offer the advantage of being maintained by IT departments.

When using a site LAN, consult your IT department regarding LAN configuration and security issues.

## Instrument Configuration

Figure 2-1 shows the components and interconnections of the 34980A/34945A configuration.

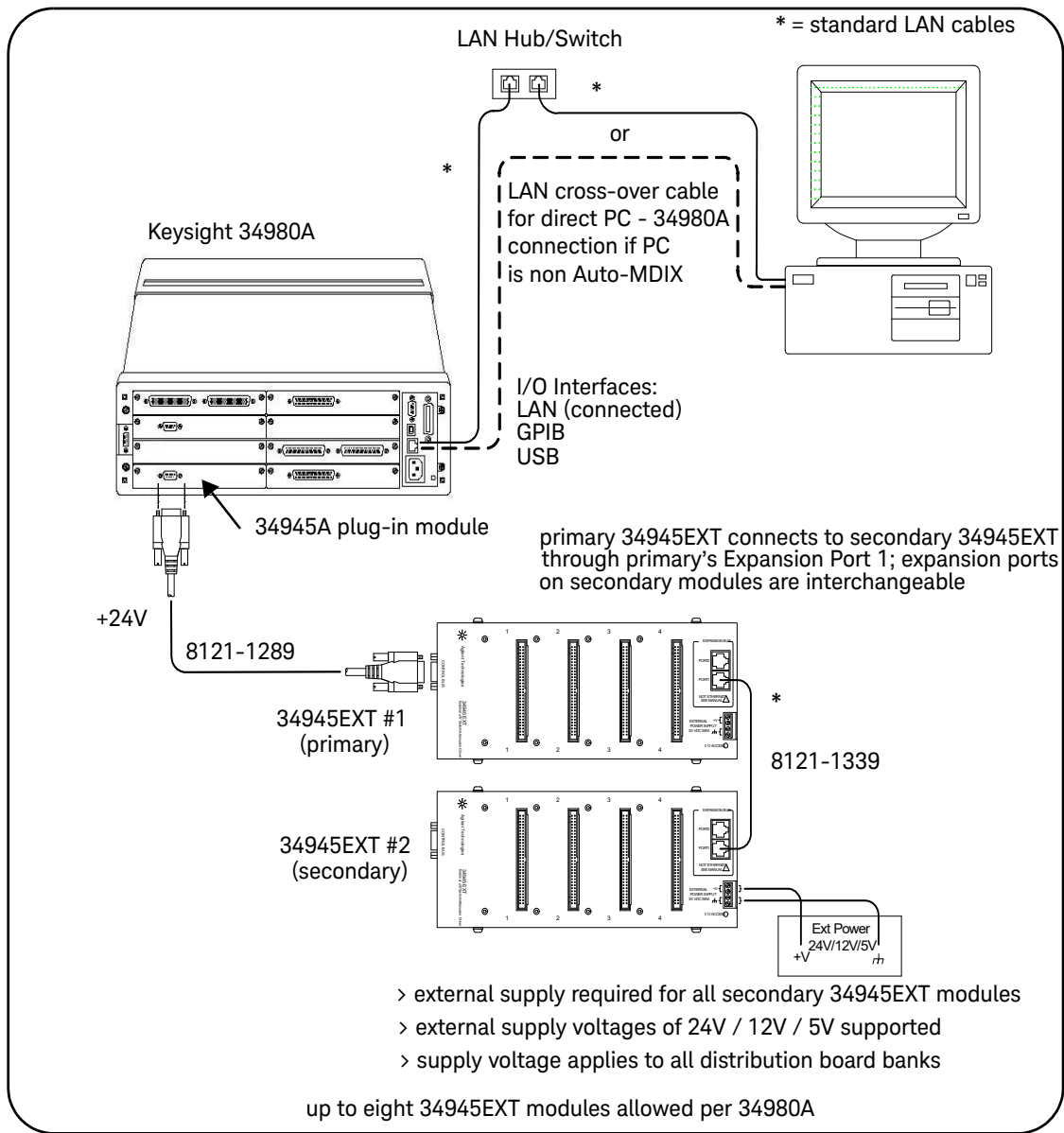

**Figure 2-1** 34945A Microwave Switch/Attenuator Driver Configuration.

**PC to 34945A.** When connecting the PC **directly** to the 34980A/34945A, the LAN cross-over cable provided with the 34945A is used. If your PC supports Auto-MDIX or contains a LAN card with Gigabit data transfer rates, the cross-over cable is not required. A standard LAN cable may be used instead.

For network configurations (private or site) that include a LAN switch or router between the PC and 34980A, standard LAN cables are used. **Do not use the cross-over cable.** GPIB and USB connections to the 34980A are also available.

**34945A to 34945EXT.** The 34945A is connected directly to the primary 34945EXT using the 9-pin D-Sub extension cable (p/n 8121-1289). 34945A - 34945EXT communication plus the 34945EXT's +24V supply voltage is provided through this connection.

**34945EXT to 34945EXT.** Multiple 34945EXT modules (up to eight per 34980A) are connected using standard LAN cables. The first cable must be connected between the primary (first) 34945EXT module's Expansion Bus Port 1 and either Expansion Port 1 or Port 2 of the second (secondary) 34945EXT module. The Expansion Ports of all subsequent secondary 34945EXTs are interchangeable.

**34945EXT to External Power Supplies.** All secondary 34945EXT modules must use an external power supply or supplies. The 34945EXT supports supply voltages of +24V, +12V, and +5V. The supply voltage applies to all distribution board banks on the 34945EXT.

## The 34945EXT Module

Microwave switches and attenuators are connected to the 34945A configuration through distribution boards (Y1150A - Y1155A) installed on the 34945EXT module (Figure 2-2).

The 34945EXT is divided into four banks organized by channel number. Any distribution board may be installed in any bank, and multiple distribution boards of the same type may be installed on the same 34945EXT module. **Distribution boards can be installed or removed with the 34945A turned on; however, the channel drive source (Figures 4-2, 4-3) must be off.**

The “I/O ACCESS” LED on the EXT module indicates communication sequences between the 34945A and the 34945EXT.

### The Y1156A Verification Board

The optional Y1156A Verification board (not shown) is used to verify the signal path from the PC to banks 1-4 on the 34945EXT. Verification of the path is recommended before connecting switches or attenuators to the distribution boards, or if a problem is suspected. See Chapter 4 for more information.

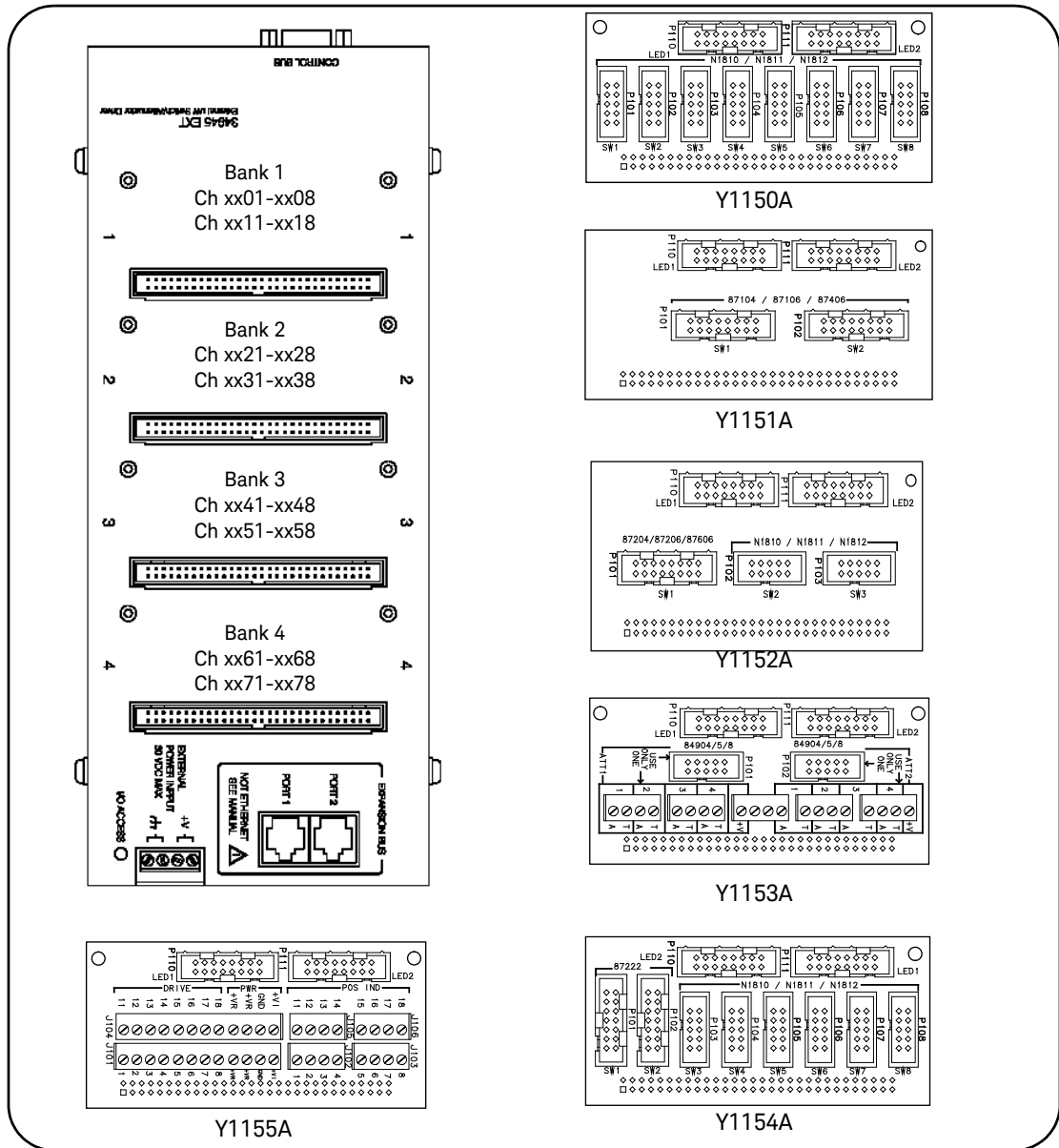

**Figure 2-2** The 34945EXT Module and Y1150A-Y1155A Distribution Boards.

## Channel Numbering

The 34945EXT uses the following channel numbering scheme:

`<slot #><34945EXT #><channel>`

where:

*slot #* - is the 34980A slot where the 34945A is installed. This is a single digit between 1 and 8.

*34945EXT #* - is the 34945EXT module. This is a single digit between 1 (the primary 34945EXT) and 8. 34945EXT modules are numbered according to their position in the daisy-chain sequence relative to the primary.

*channel* is the channel number in the specified EXT module bank.

Channel numbers are specified using two digits. Examples of the channel numbers for two 34945EXT modules (the primary and one secondary) are shown below.

34945EXT #1 (primary)			34945EXT #2 (secondary)		
Bank	Channels	Channels	Bank	Channels	Channels
Bank 1	x101 to x108	x111 to x118	Bank 1	x201 to x208	x211 to x218
Bank 2	x121 to x128	x131 to x138	Bank 2	x221 to x228	x231 to x238
Bank 3	x141 to x148	x151 to x158	Bank 3	x241 to x248	x251 to x258
Bank 4	x161 to x168	x171 to x178	Bank 4	x261 to x268	x271 to x278

An example of this syntax is for a 34945A module installed in slot 2 of the 34980A is:

**ROUT:CLOS (@2141)**

which closes **channel 41** (bank 3) on **34945EXT module number 1**.

A range of channels for a 34945A installed in **slot 1** of the 34980A can be specified as:

**ROUT:CLOS (@1101:1278)**

which in this example closes all channels on the primary 34945EXT (**module number 1**) and all channels on the secondary 34945EXT (**module number 2**). Channel ranges can extend across banks and across 34945EXT modules.

## Module- and Bank-Level Commands

Selected commands within the 34945A SCPI command set contain parameters that specify the 34945EXT itself, or a bank on the 34945EXT rather than a channel list. These commands include:

```
ROUTE:RMOdule:BANK:DRIVE:MODE
ROUTE:RMOdule:BANK:LED:DRIVE:ENABLE
ROUTE:RMOdule:BANK:LED:DRIVE:LEVel
ROUTE:RMOdule:BANK:PRESet
ROUTE:RMOdule:DRIVE:LIMit
ROUTE:RMOdule:DRIVE:SOURce:BOOT
ROUTE:RMOdule:DRIVE:SOURce:IMMediate
```

For these commands, the 34945EXT address is in the form:

```
<slot #><34945EXT #><00>
```

where:

*slot #* - is the 34980A slot where the 34945A is installed. This is a single digit between 1 and 8.

*34945EXT #* - is the 34945EXT module. This is a single digit between 1 (the primary 34945EXT) and 8. 34945EXT modules are numbered according to their position in the daisy-chain sequence relative to the primary.

For example, for a 34945A installed in 34980A **slot 1**:

```
ROUT:RMOD:BANK:PRES 2, (@1200)
```

presets bank 2 on 34945EXT secondary **module number 2**.

## Relay/Channel Relationship

The Keysight switches and attenuators listed in Table 1-2 are latching relays. Therefore, there is a relay coil for each switch or attenuator position. In the factory default configuration (`SYSTEM:RMOdule:RESet <slot>`), **a distribution board channel is assigned to each relay coil**. There are 16 channels per distribution board.

### Channel Pairing

Channel numbers on the distribution boards are arranged to facilitate channel pairing for dual-coil switches and attenuators. In paired configurations, channels 01-08 are paired with 11-18 (bank 1), 21-28 with 31-38 (bank 2), 41-48 with 51-58 (bank 3), and 61-68 with 71-78 (bank 4). Paired channels are controlled by a single command (e.g. **OPEN** or **CLOSE**) in which only the **lower** channel of the pair is specified. When a command (**OPEN** or **CLOSE**) is sent, the operation sends a drive pulse to either the first or second channel in the pair - either opening or closing the channel.

For the channel pair 01/11, the following syntax:

**ROUT:CLOS (@1101)** - sends a drive pulse to the upper channel (1111)

**ROUT:OPEN (@1101)** - sends a drive pulse to the lower channel (1101)

### Non-Paired Channels

When channel pairing is not enabled (e.g. for single-coil drive), there are 16 channels per bank: 01-08/11-18 (bank 1) ... 61-68/71-78 (bank 4). Note that the channel numbers within the bank are not consecutive.



## Internal/External Power Supply Considerations

As shown in Figure 2-1, the channel drive source for switches and attenuators in the 34945A RF Switch Platform is provided through the internal (or an external) power supply. The internal/external supply must meet the quiescent (continuous) and switching current requirements of the switches in your application. The following sections provide additional information on these requirements and the recommended configuration of these supplies.

### Internal Supply

The primary 34945EXT (Figure 2-1) can receive its power from either the internal +24V supply of the 34945A or from an external supply. When using the internal +24V supply, the quiescent (continuous) current draw must not exceed 100 mA, with a switching pulse current that does not exceed 200 mA. The duration of the switching pulse must be  $\leq$  15 ms with a 25% duty cycle. The remainder of the duty cycle (75%) allows recovery time for the supply to provide the next pulse.

If the current limit is exceeded, an overcurrent condition can occur which shuts down the internal supply. When this happens, you must remove the device/condition causing the overcurrent and **either** send the **SYSTem:RMOdule:RESet <slot>** command to reset all 34945EXT modules, or cycle power on the 34980A mainframe. See “Overcurrent Conditions” in Chapter 5 for more information.

The quiescent current requirement of the 34945EXTs themselves is accounted for by the supply rating and is not included in quiescent current and switching current calculations. Only the specified currents (quiescent, switching) of the **switch** must be considered.

As an example, the Keysight 87104/87106A, B, C coaxial switches specify the following:

Supply current (switching: pulse width =15 ms:Vcc = 24 VDC): **200 mA** Nom

Supply current (quiescent): **50 mA** Max



The second consideration regarding the external supply are the quiescent current and switching current specifications of the switch. Using the Keysight 87104/87106A, B, C coaxial switches from the internal supply example, the switch specifications again are:

Supply current (switching: pulse width =15 ms;Vcc = 24 VDC): **200 mA** Nom  
 Supply current (quiescent): **50 mA** Max

The quiescent current required when switching does not occur is:

[34945EXT quiescent current from 24V] + [87104 / 87106 switch quiescent current]  
 [24V: 1.2W / 24V = **50 mA**] + [**50 mA**] = **100 mA**

For a single 34945EXT driven by an external supply, the current required for actuating a 87104/87106 switch is:

[34945EXT quiescent current from 24V] + [switch quiescent current] +  
 [switching current]

[24V: 1.2W / 24V = **50 mA**] + [**50 mA**]+  
**[200 mA] = 300 mA** (15 ms pulse, 100 mA quiescent)

In summary, when using an external supply the current calculations must include the quiescent current requirement of the 34945EXT, plus the quiescent current requirement of each switch. These quantities are then added to the switching (pulse) current of the device.

## Keysight Switch/Attenuator Configuration

This section contains pin definitions and orientation to assist in connecting the Keysight switches/attenuators listed in Table 1-2 to their corresponding Y115x distribution boards.

Only general information is provided. Refer to the reference documents listed in Table 1-2 for more information on the individual switches. Refer also to Table 1-2 for the number of switches allowed per distribution board.

### Keysight N1810 / N1811 / N1812 Series Coaxial Switches

Figure 2-3 shows the pin definitions and orientation for the Y1150A, Y1152A, and Y1154A distribution board connectors and the Keysight N181x series switches.

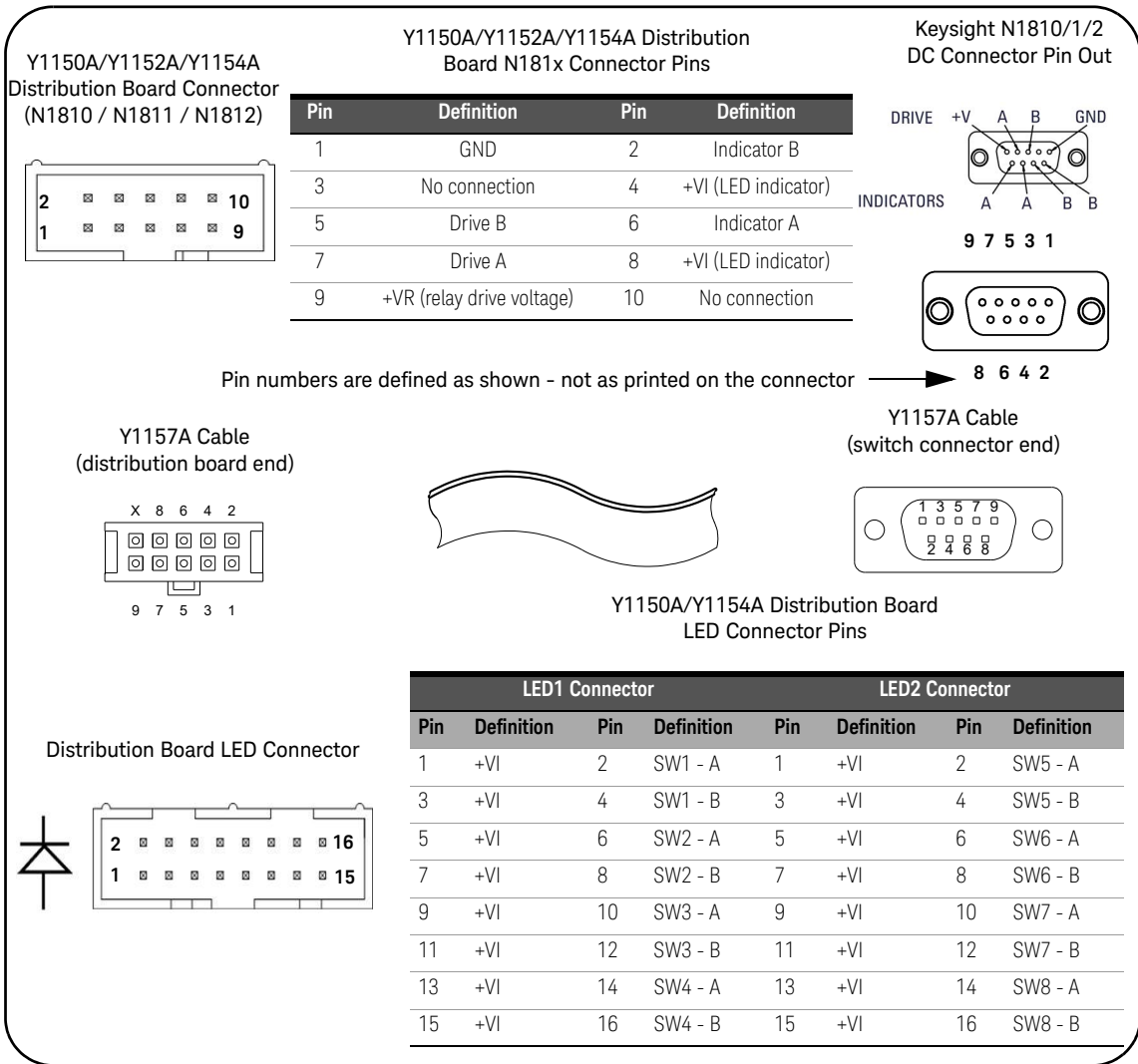

**Figure 2-3** Keysight N1810 / N1811 / N1812 Pin Definition and Orientation.

**NOTE**

The pin information for the Keysight switches shown in Figure 2-3 was taken from the reference documents listed in Table 1-2. Refer to Table 1-2 for information on accessing these documents from the Keysight web-site.

## Keysight 87104/87106/87406 - L7104/L7106/L7204/L7206 Coaxial Switches

Figure 2-4 shows the pin definitions and orientation for the Y1151A distribution board, the Keysight 87104, 87106, and 87406 series switches, and the L7104, L7106, L7204, and L7206 L series switches.

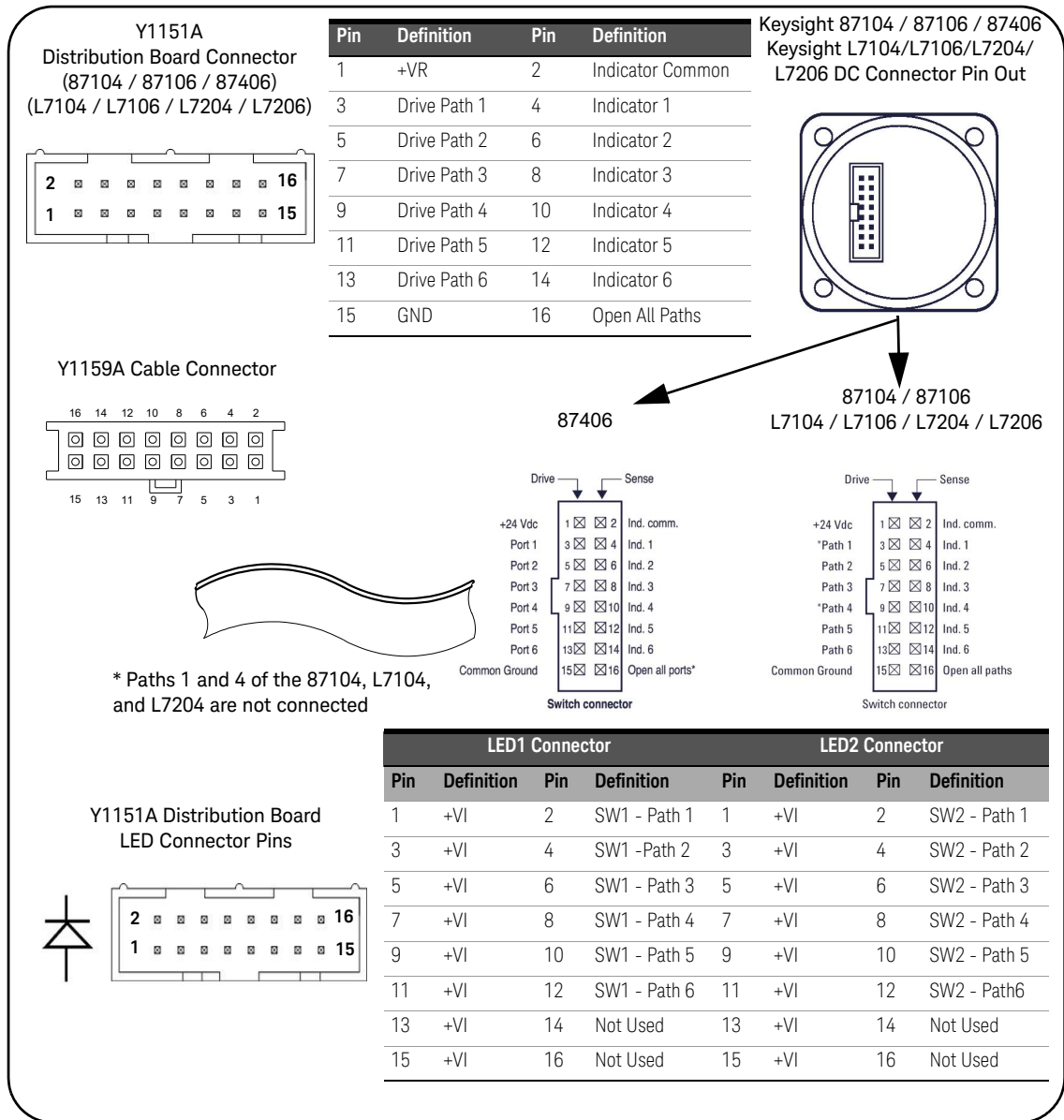

**Figure 2-4** Keysight 871x / 874x / L71x / L72x Pin Definition and Orientation.

**NOTE**

The pin information for the Keysight switches shown in Figure 2-4 was taken from the reference documents listed in Table 1-2. Refer to Table 1-2 for information on accessing these documents from the Keysight web-site.

---

## Keysight 87204 / 87206/ 87606 Series Coaxial Switches

Figure 2-5 shows the pin definitions and orientation for the Y1152A distribution board and the 87204, 87206, and 87606 series switches.

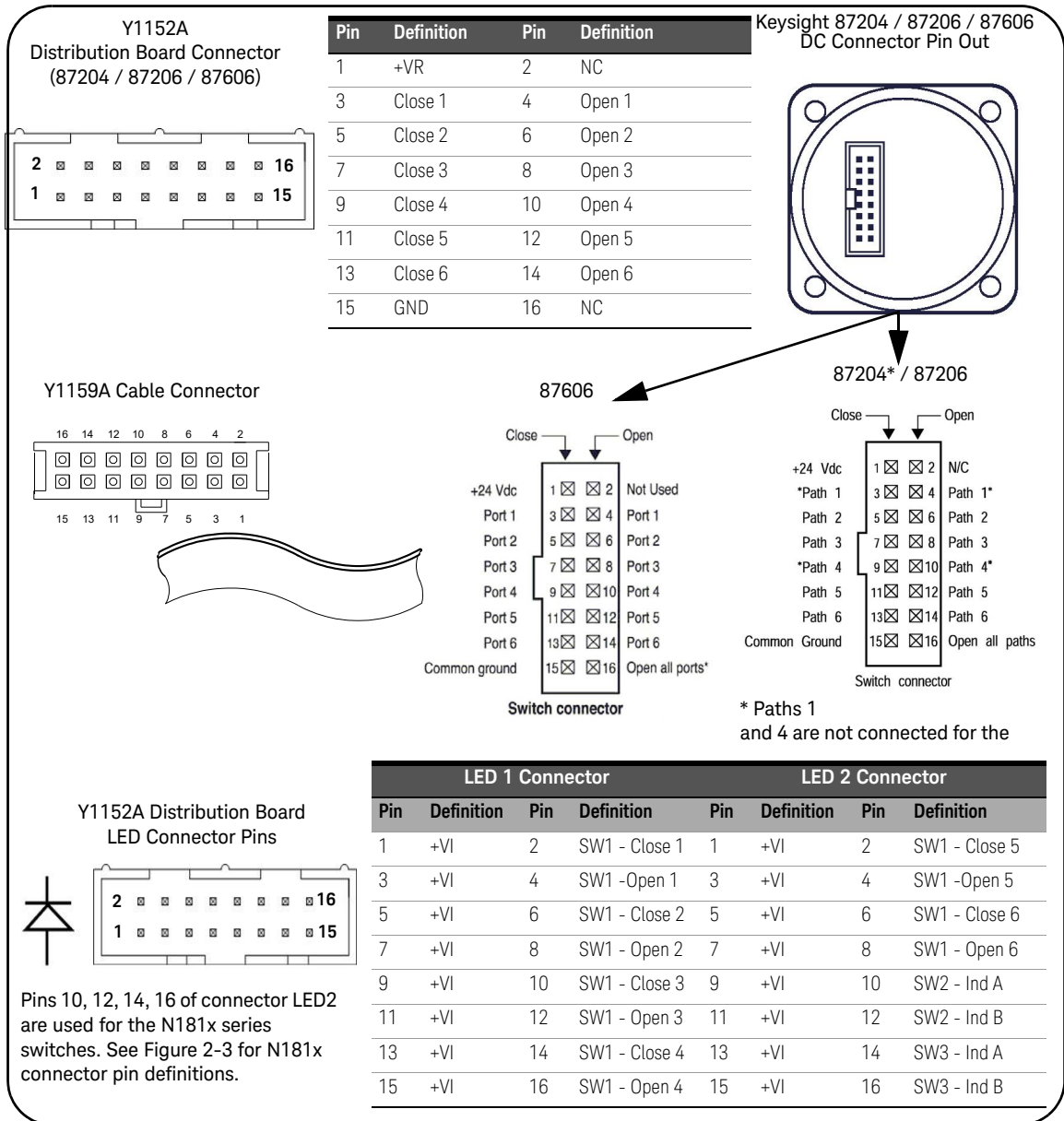

**Figure 2-5** Keysight 87204 / 87206 / 87606 Pin Definition and Orientation.



**NOTE**

The pin information for the Keysight switches shown in Figure 2-5 was taken from the reference documents listed in Table 1-2. Refer to Table 1-2 for information on accessing these documents from the Keysight web-site.

---

## Keysight 8767/8/9M Microwave Single-Pole Multi-Throw Switches

Figure 2-6 identifies the terminals of the 8767/8/9M switches and typical connections to the Y1153A distribution board (\* 8767M shown).

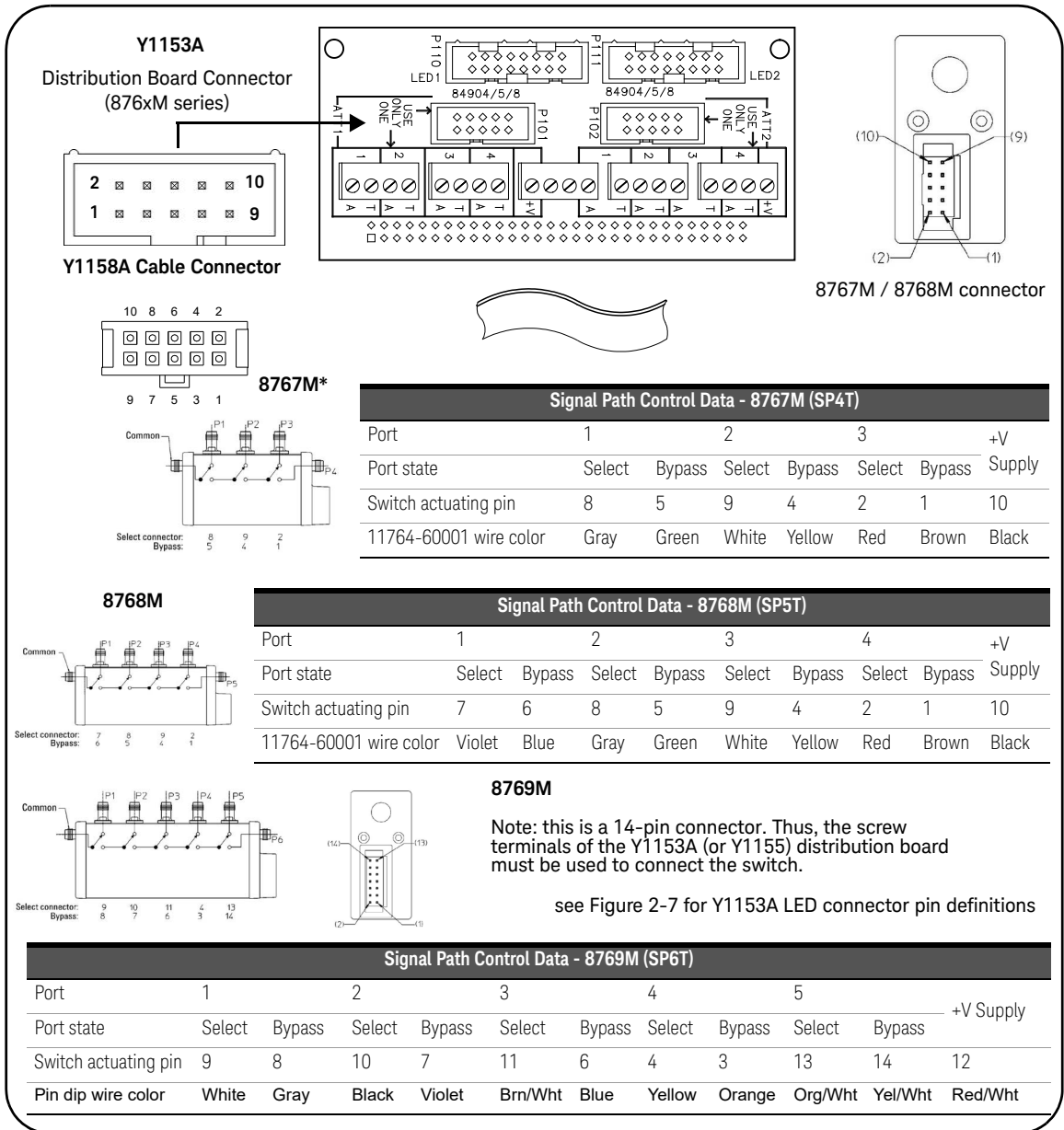

Figure 2-6 Keysight 8767/8/9M Port Definitions and Connections.

**NOTE**

The terminal information for the Keysight switches shown in Figure 2-6 was taken from the reference documents listed in Table 1-2. Refer to Table 1-2 for information on accessing these documents from the Keysight web-site.

---

## Keysight 84904/6/7 K/L and 84904/5/8M Programmable Step Attenuators

Figure 2-7 identifies the pins of the 84904/6/7 K/L and 84904/5/8M step attenuators and their connections to the Y1153A distribution board.

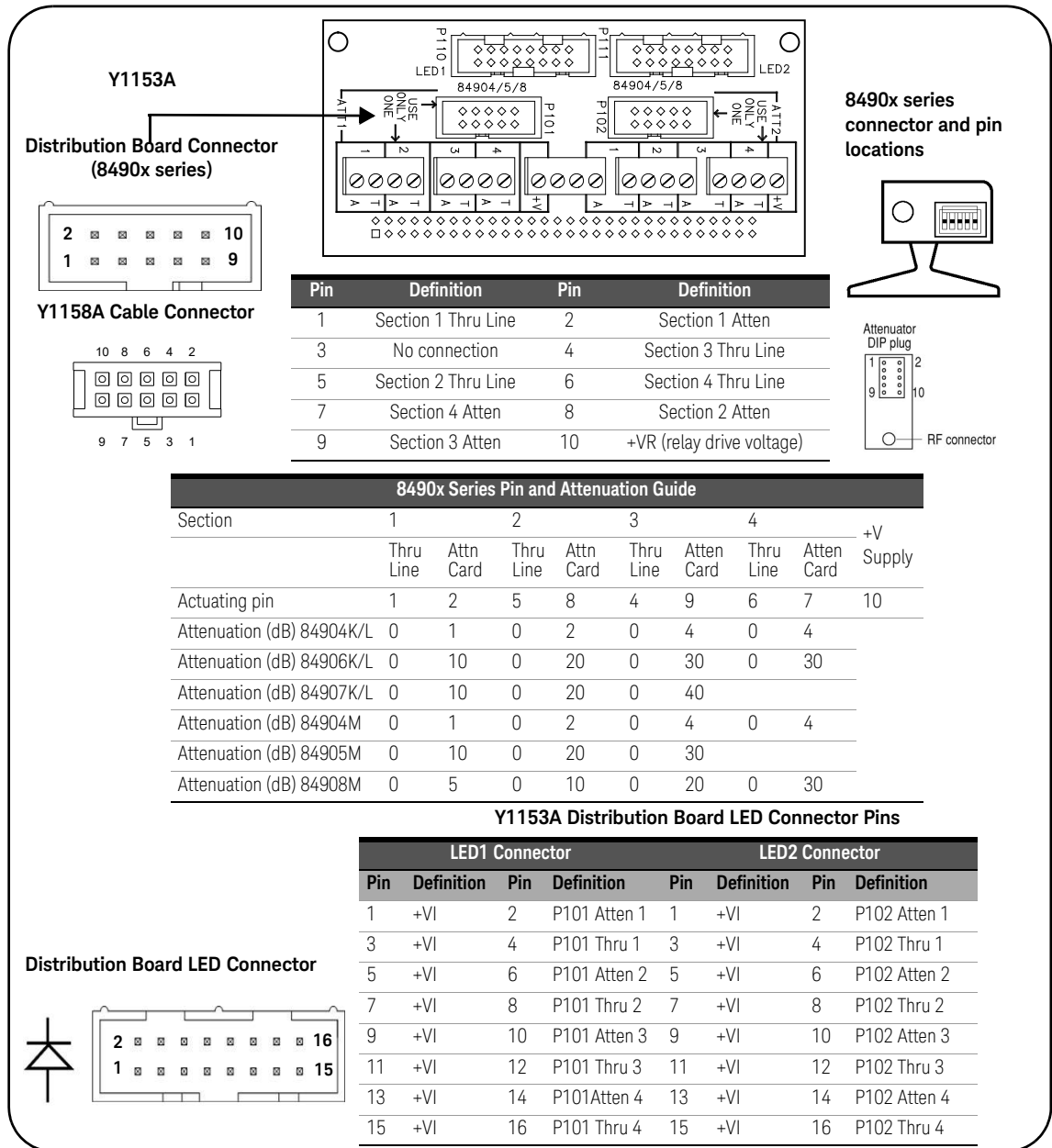

Figure 2-7 Keysight 84904/6/7 K/L Attenuator Pin Definitions and Connections.

**NOTE**

The terminal information for the Keysight switches shown in Figure 2-7 was taken from the reference documents listed in Table 1-2. Refer to Table 1-2 for information on accessing these documents from the Keysight web-site.

### Keysight 8494 /5/ 6/ 7 Programmable Step Attenuators

Figure 2-8 identifies the pins of the 8494/5/6/7 step attenuators and typical connections to the Y1153A distribution board.

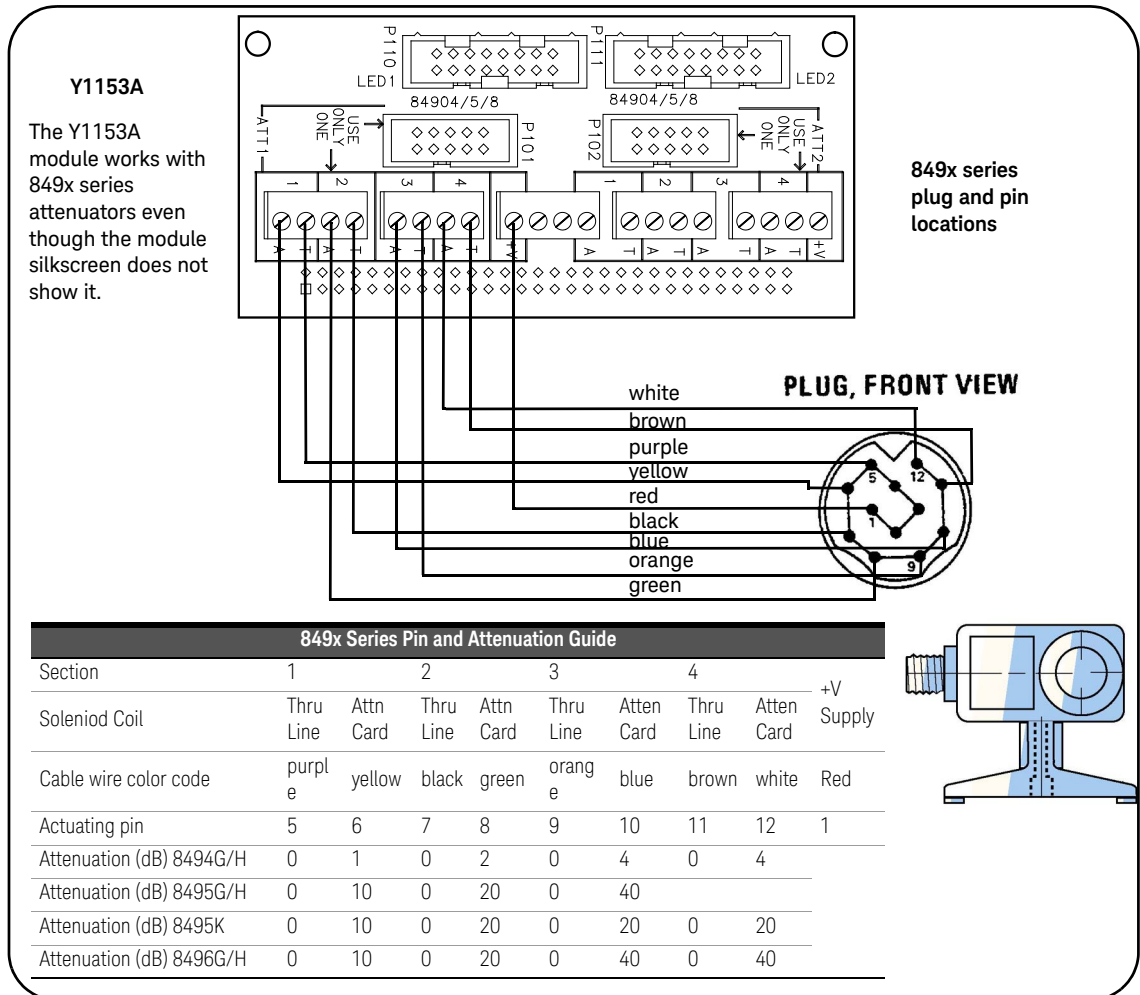

**Figure 2-8** Keysight 8494/5/ 6/7 Attenuator Pin Definitions and Connections.

**NOTE**

The terminal information for the Keysight switches shown in Figure 2-8 was taken from the reference documents listed in Table 1-2. Refer to Table 1-2 for information on accessing these documents from the Keysight web site.

---

## Keysight 849xG/H/K Programmable Step Attenuators Option 016

Figure 2-9 identifies the pins of the 8494/5/6/7 Option 016 Step Attenuators and typical connections to the Y1153A distribution board.

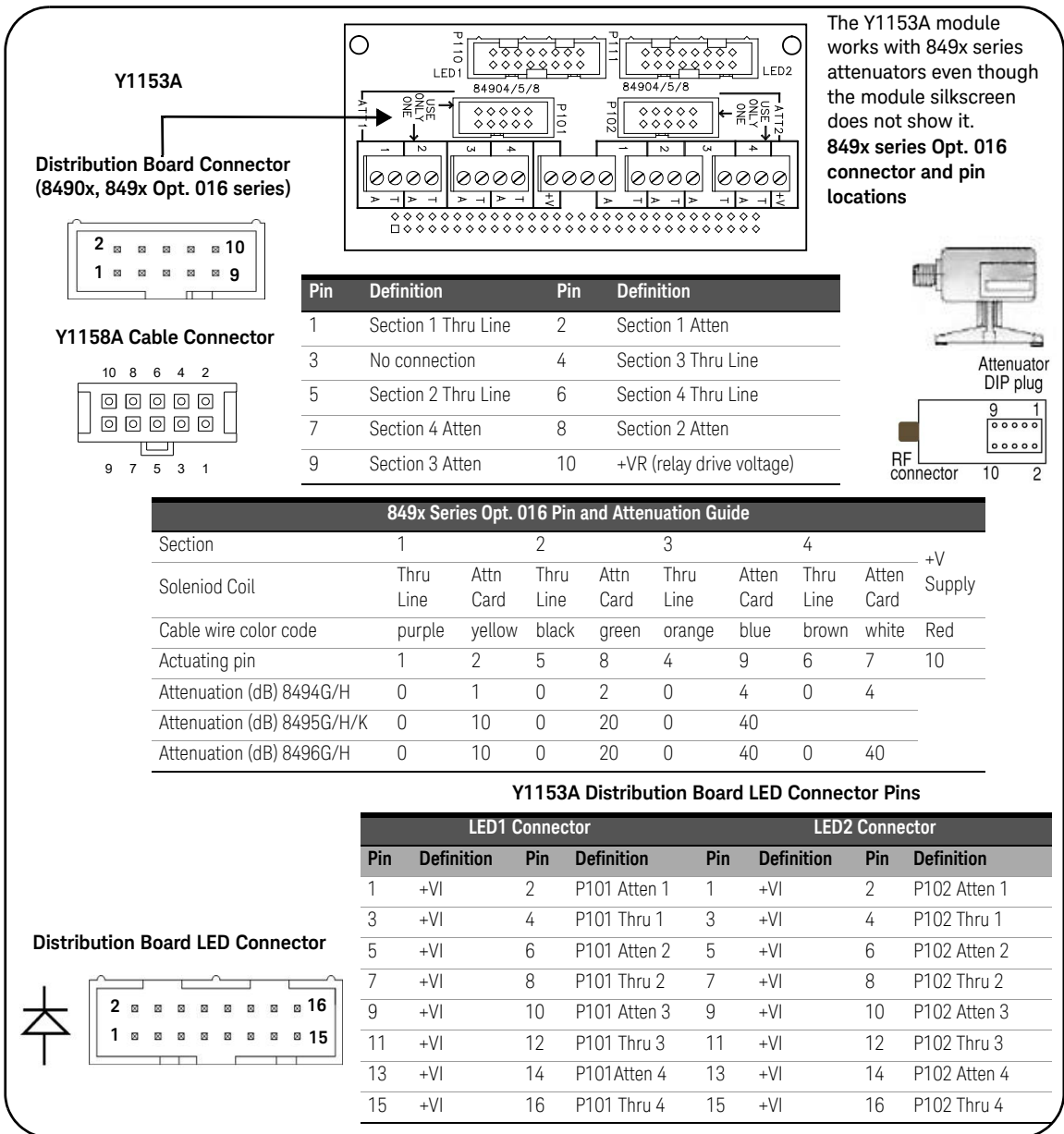
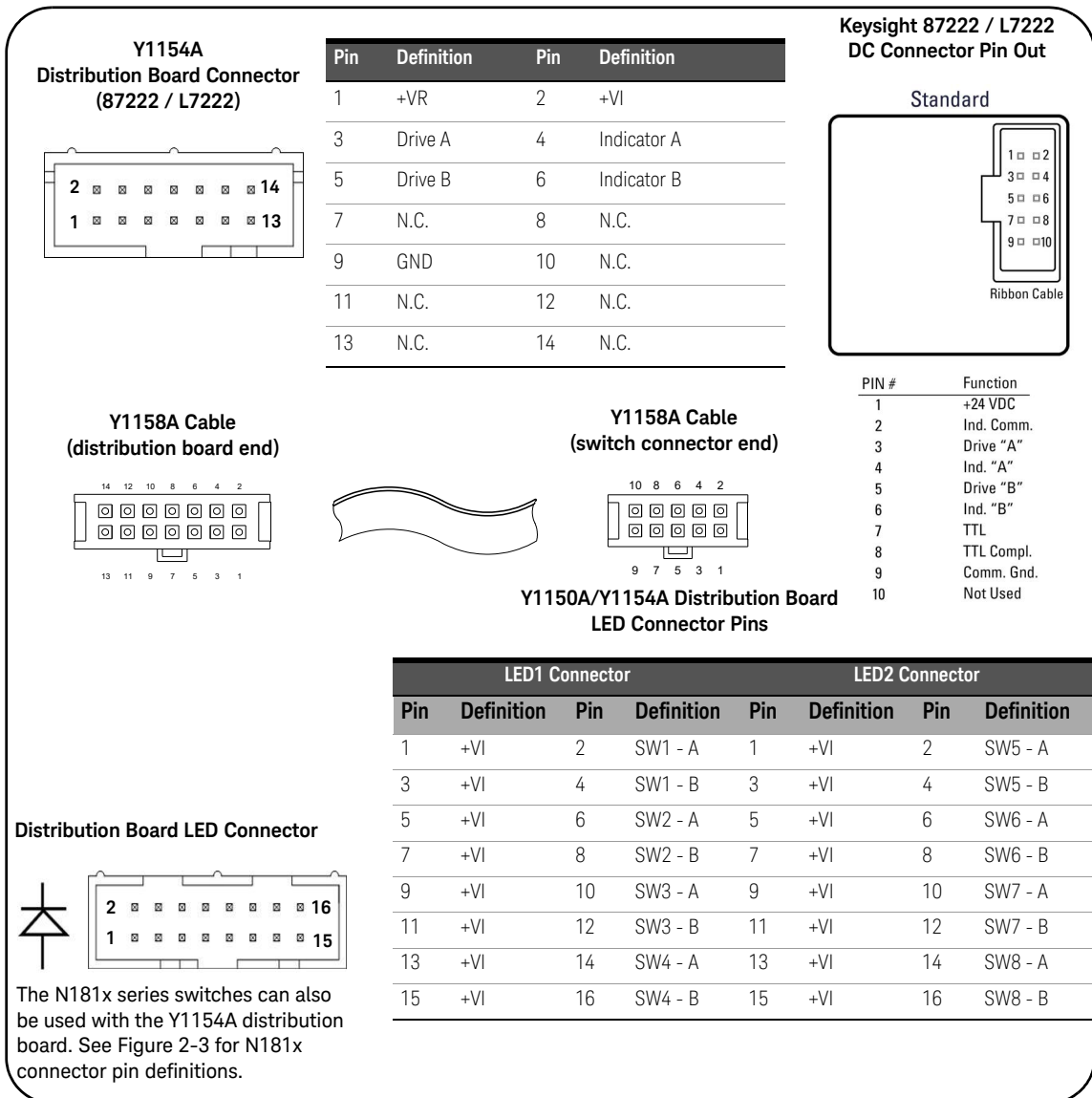

**Figure 2-9** Keysight 8494/5/6/7 Opt. 016 Att. Pin Definitions and Connections.

## Keysight 87222 and L7222 Coaxial Switches

Figure 2-10 shows the pin definitions and orientation for the Y1154A distribution board and the Keysight 87222 and L7222 coaxial transfer switches.





**Figure 2-10** Keysight 87222 / L7222 Pin Definition and Orientation.

**NOTE**

The pin information for the Keysight switches shown in Figure 2-9 was taken from the reference documents listed in Table 1-2. Refer to Table 1-2 for information on accessing these documents from the Keysight web-site.

---

## Keysight 8762 / 8763 / 8764 Series Coaxial Switches

Figure 2-11 identifies the terminals of the 8762/8763/8764 switches and typical connections to the Y1155A distribution board.

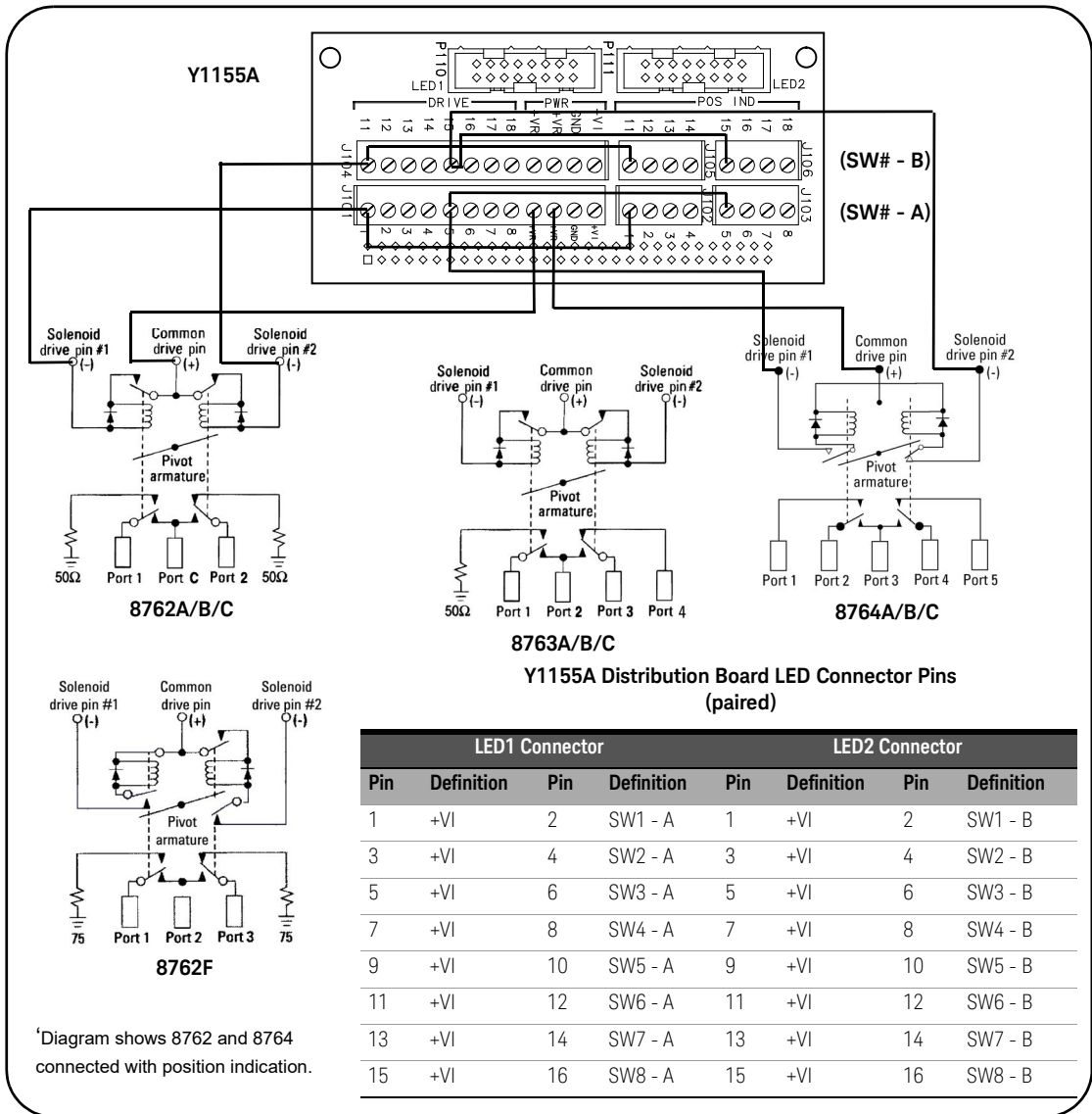

Figure 2-11 Keysight 8762 / 8763 / 8764 Terminal Connections.

**NOTE**

The terminal information for the Keysight switches shown in Figure 2-10 was taken from the reference documents listed in Table 1-2. Refer to Table 1-2 for information on accessing these documents from the Keysight web-site.

---

## Keysight 8765 Series Coaxial Switches

Figure 2-12 identifies the terminals of the 8765 switches and typical connections to the Y1155A distribution board (with position indication).

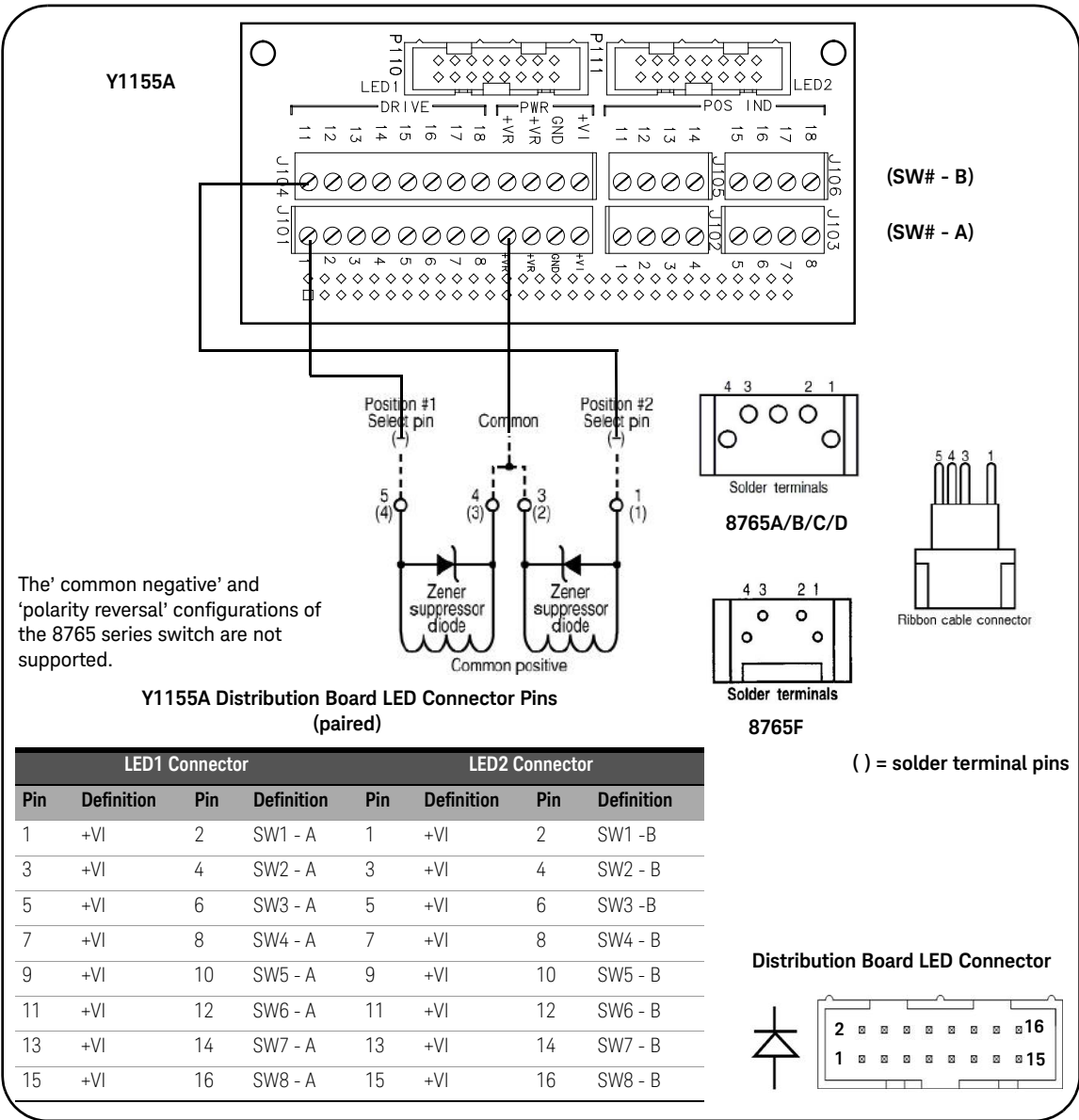

Figure 2-12 Keysight 8765 Terminal Connections.

**NOTE**

The terminal information for the Keysight switches shown in Figure 2-11 was taken from the reference documents listed in Table 1-2. Refer to Table 1-2 for information on accessing these documents from the Keysight web-site.

---

## Keysight 8766/7/8/9K Microwave Single-Pole Multi-Throw Switches

Figure 2-13 identifies the terminals of the 8766/7/8/9K switches and typical connections to the Y1155A distribution board (\* 8767K shown).

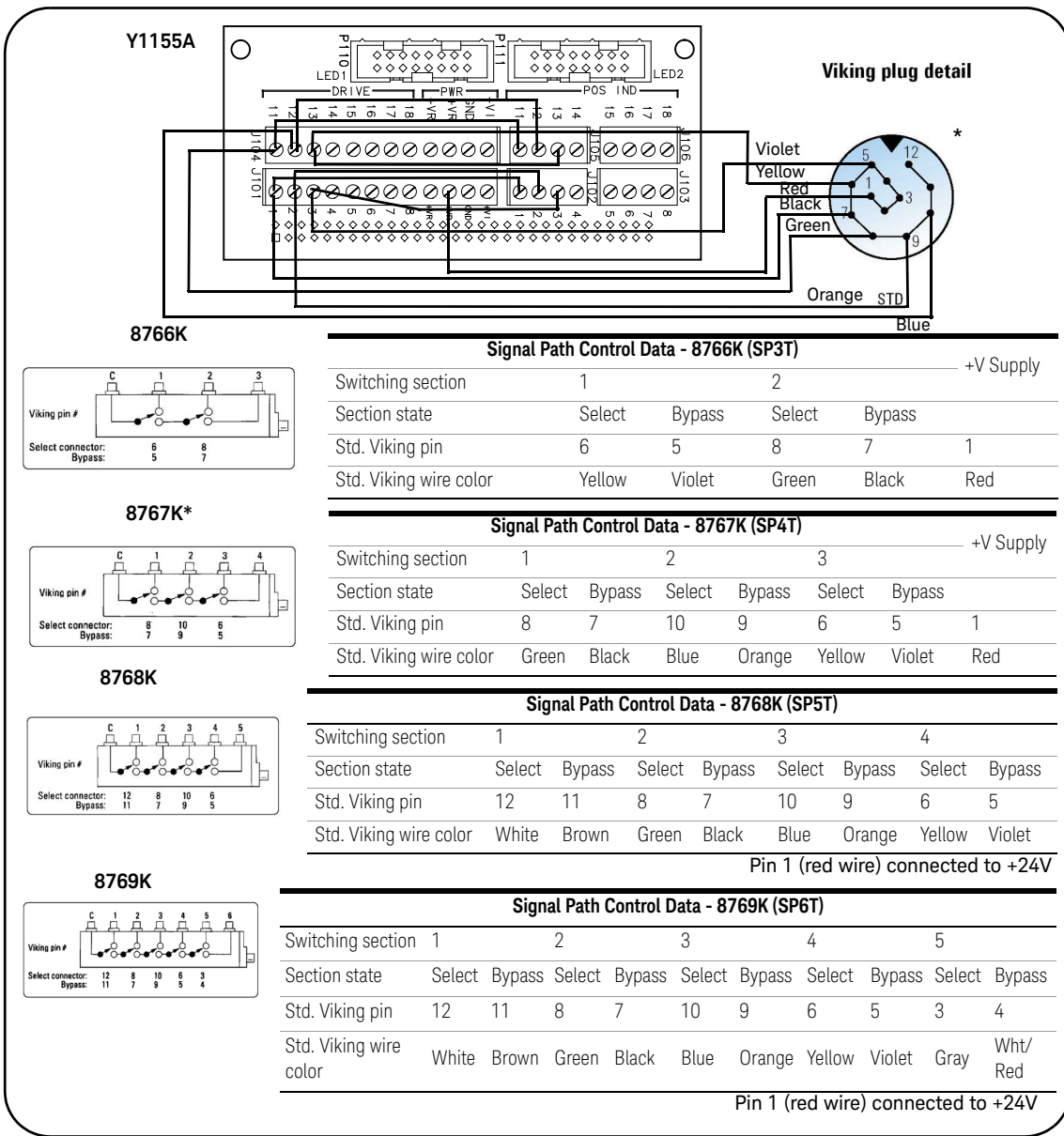

Figure 2-13 Keysight 8766/7/8/9K Section Definitions and Connections.

**NOTE**

The terminal information for the Keysight switches shown in Figure 2-12 was taken from the reference documents listed in Table 1-2. Refer to Table 1-2 for information on accessing these documents from the Keysight web-site.

### Keysight U9397A / U9397C FET Solid State Switches

Figure 2-14 identifies the terminals of the U9397A/C switches and typical connections to the Y1155A distribution board (with position indication).

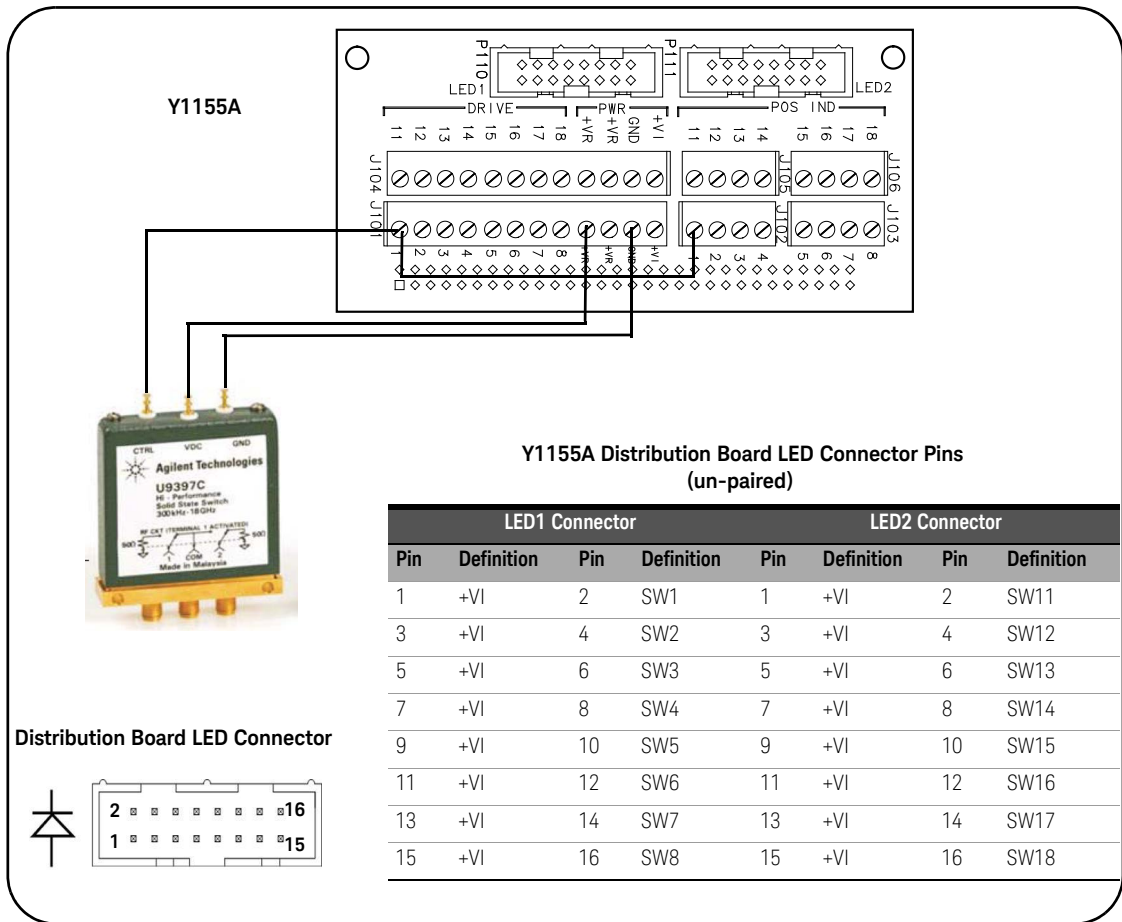

**Figure 2-14** Keysight U9397A / U9397C Connector Definitions and Connections.



**NOTE**

The terminal information for the Keysight switches shown in Figure 2-13 was taken from the reference documents listed in Table 1-2. Refer to Table 1-2 for information on accessing these documents from the Keysight web-site.

---

THIS PAGE HAS BEEN INTENTIONALLY LEFT BLANK.

# 3 Software Installation and Configuration

Software Requirements	76
Adding Instruments to the Interface	80
Firmware and Driver Updates	93
Downloading IVI-COM Driver and LabVIEW Driver Updates	97

This chapter contains information on IO libraries and drivers required to program the 34945A from selected development environments. The chapter also provides information on configuring the instrument's LAN, GPIB, and USB interfaces and on updating the instrument firmware.

Refer to this chapter for specific information on:

- development environments and IO library/driver requirements
- installing the Keysight IO Libraries
- installing IVI (instrument) drivers
- LAN, GPIB, and USB configuration using Keysight Connection Expert
- updating the 34945A firmware and IVI Drivers

## Software Requirements

The manner and environments available to program the 34945A are dependent upon the IO libraries and drivers installed. Table 3-1 summarizes the environments, IO driver recommendations, and the location where the specific drivers and libraries can be found.

**Table 3-1** 34945A Development Environments and Drivers.

Interface	Development Environment	IO Driver Recommendations
LAN	Web-enabled instrument interface > SCPI Command Interface window	Java™-enabled Web browser (available from <a href="http://www.java.com">www.java.com</a> )
LAN, GPIB, USB	Keysight Connection Expert > Interactive IO window	Keysight IO Libraries
LAN, GPIB, USB	Microsoft® Visual Studio® 6.0 > Visual C++	<b>VISA</b> - Keysight IO Libraries or <b>IVI-C</b> - <a href="http://www.keysight.com/find/IVI">www.keysight.com/find/IVI</a>
LAN, GPIB, USB	Microsoft® Visual Studio® 6.0 > Visual Basic	<b>VISA-COM</b> - Keysight IO Libraries or <b>IVI-COM</b> - <a href="http://www.keysight.com/find/IVI">www.keysight.com/find/IVI</a>
LAN, GPIB, USB	Microsoft® Visual Studio® .NET > CSharp, C++, Visual Basic 7.0	<b>VISA-COM</b> - Keysight IO Libraries or <b>IVI-COM</b> - <a href="http://www.keysight.com/find/IVI">www.keysight.com/find/IVI</a>
LAN, GPIB, USB	Keysight VEE	<b>IVI-COM</b> - <a href="http://www.keysight.com/find/IVI">www.keysight.com/find/IVI</a>
LAN, GPIB, USB	National Instruments LabVIEW™	LabVIEW Plug&Play (with 34980A native mode driver) <b>IVI-C</b> - <a href="http://www.keysight.com/find/IVI">www.keysight.com/find/IVI</a>
LAN, GPIB, USB	National Instruments LabWindows/CVI	<b>IVI-C</b> - <a href="http://www.keysight.com/find/IVI">www.keysight.com/find/IVI</a>

**NOTE**

Using the LAN to program the 34945A from the instrument's Web interface requires a Web-browser but no additional (i.e. user-installed) instrument drivers or libraries. The Web interface provides full access to 34945A functionality and its IO command log feature logs (SCPI) commands sent to the instrument via interface dialog boxes. The commands can then be copied and transferred to other development environments. Refer to Chapter 4 for more information on programming using the Web interface.

---

## Installing the Keysight IO Libraries

The Keysight IO Libraries include the VISA and VISA-COM libraries used for programming the 34945A in Microsoft® development environments (Table 3-1). The VISA and VISA-COM libraries allow you to send commands from the 34945A SCPI command set to the instrument (see “34945A Programmers Reference Help” which can be downloaded from [www.keysight.com/find/34980A](http://www.keysight.com/find/34980A)). The IO libraries also include the 'Configuration Expert' utility described later in this chapter.

**NOTE**

The Keysight IO Libraries must be installed prior to installing drivers (e.g. IVI-C, IVI-COM).

---

The IO Libraries may be downloaded from the Keysight Developer Network website at:

<http://www.Keysight.com/find/iosuite>

Before installing the IO libraries, review Table 3-2 to verify that your computer meets the specifications required for the software.

**Table 3-2** Keysight IO Libraries Suite System Requirements.

<b>Processor</b>	450 MHz Intel Pentium® II or higher
<b>Operating System</b>	Windows XP Professional or Home Edition (Service Pack 1 or later) Windows 2000 Professional (Service Pack 4 or later)
<b>Web Browser</b>	Microsoft Internet Explorer 5.01 or greater (recommended)
<b>Available Memory</b>	128 MB (256 MB or greater recommended)
<b>Available Disk Space</b>	225 MB required for installation: <ul style="list-style-type: none"> <li>- 160 MB for Microsoft .NET Framework</li> <li>- 65 MB for Keysight IO Libraries Suite</li> </ul> 175 MB required for operation: <ul style="list-style-type: none"> <li>- 110 MB for Microsoft .NET Framework</li> <li>- 65 MB for Keysight IO Libraries Suite</li> </ul>
<b>Video</b>	Super VGA (800x600) with 256 colors

**NOTE**

If another vendor's implementation of VISA (Virtual Instrument Software Architecture) is currently installed on your computer, continue installation of the Keysight IO Libraries by installing Keysight VISA in *side-by-side* mode. More information on *side-by-side* operation can be found in the "IO Libraries Suite Help" (available after installation is complete) under "Using Keysight's and Other Vendors' Products Together".

After the IO libraries have been successfully installed, you have the option of starting 'Connection Expert' or closing the installation wizard. If you choose to start Connection Expert, continue with the "Interface Configuration" section of this chapter. Otherwise, continue with instrument driver installation as described below.

## Installing Instrument Drivers

Interchangeable Virtual Instrument (IVI) drivers are available for programming the 34945A using Microsoft® development environments, Keysight VEE, or National Instruments® LabVIEW™ (see Table 3-1).

Install the appropriate driver based on the development environment you are using. **Accept all default directories specified during installation if prompted. Setup type “Typical” is applicable for most users.** (As previously noted, installing the Keysight IO Libraries installs the IVI Shared Components.)

### NOTE

Installing the Keysight IO Libraries also installs the Interchangeable Virtual Instrument (IVI) Shared Components. The IVI Shared Components are required before IVI drivers (e.g. IVI-COM, IVI-C) can be downloaded from [www.keysight.com/find/IVI](http://www.keysight.com/find/IVI).

---

## Adding Instruments to the Interface

This section contains information for configuring the 34945A LAN, GPIB, and USB interfaces using the Keysight IO Libraries 'Connection Expert' utility.

### Configuring the LAN Interface

With the 34945A turned on and connected to the PC (Chapter 2: Figure 2-1), start the Connection Expert utility by clicking the 'IO (control)' icon and selecting "Keysight Connection Expert" from the pop up menu as shown in Figure 3-2.

#### NOTE

The procedure for using Keysight Connection Expert to locate and configure the 34945A is independent of the type of network you are using (private or site) and the network devices present (switches or routers).

Figures showing the following Keysight Connection Expert windows represent Keysight IO Libraries Suite 15.0.

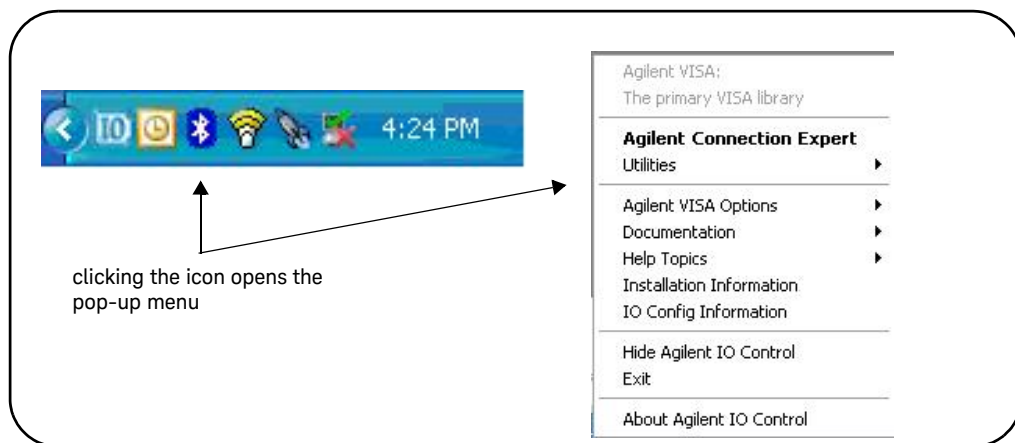
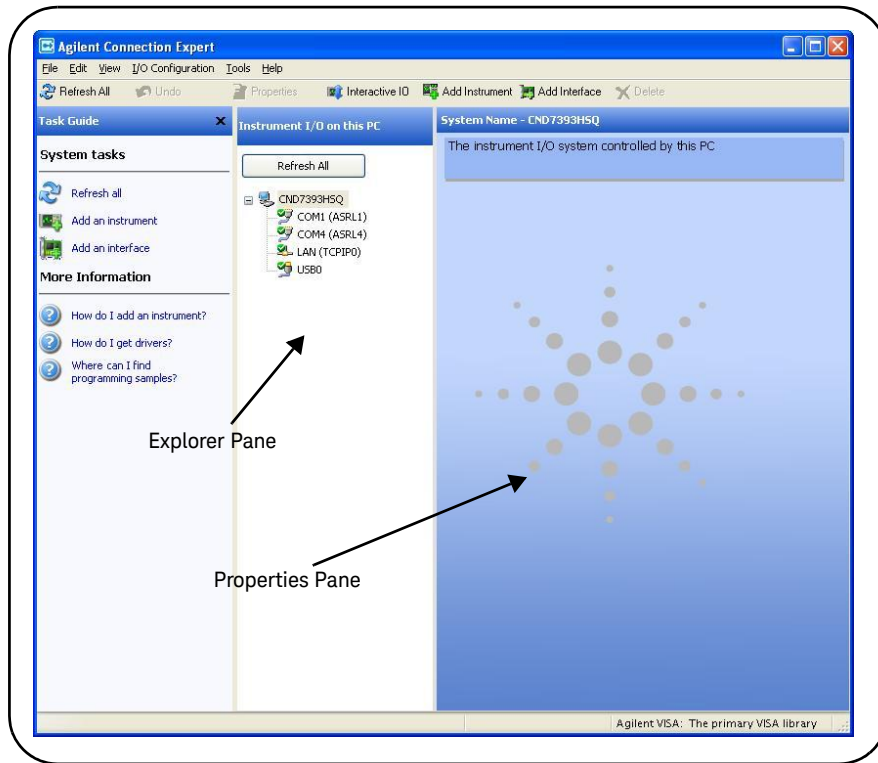

**Figure 3-1** Starting Connection Expert.



## Locating the Instruments

Keysight Connection Expert opens with a “welcome screen” and window similar to that shown in Figure 3-3. The computer interfaces available are configured during installation of the Keysight IO Libraries and are displayed in the left column (**Explorer** pane), the properties of the configured interface are displayed in the right column (**Properties** pane).



**Figure 3-2** Keysight Connection Expert (ACE) Opening Window.

### 3 Software Installation and Configuration

To search the network for instruments, click on “Add Instrument” located on the Connection Expert tool bar. From the “Add Instrument” window, select the LAN (TCPIP0) interface and click on ‘OK’. See Figure 3-4.

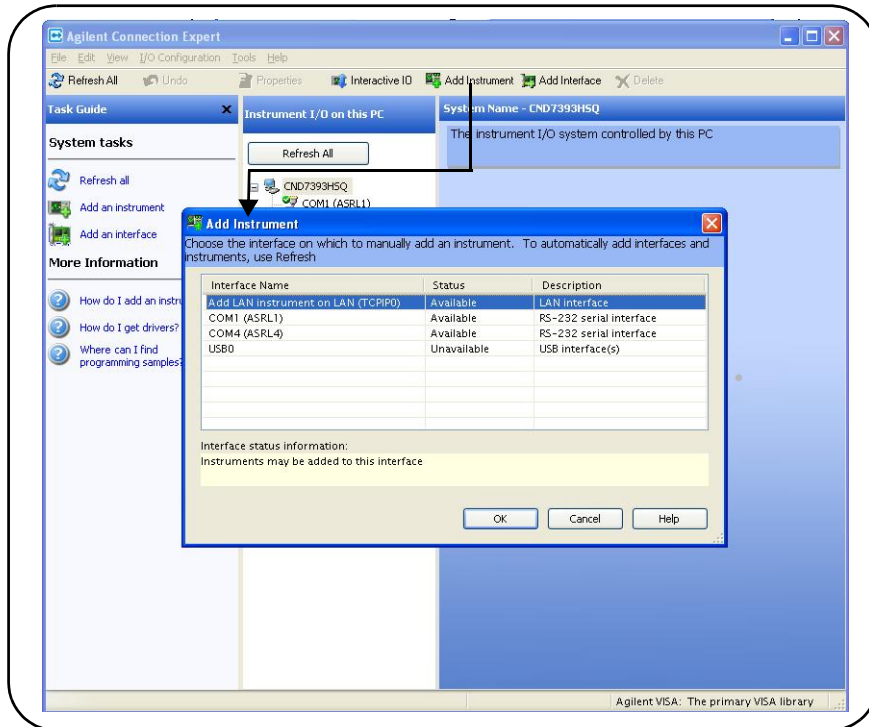
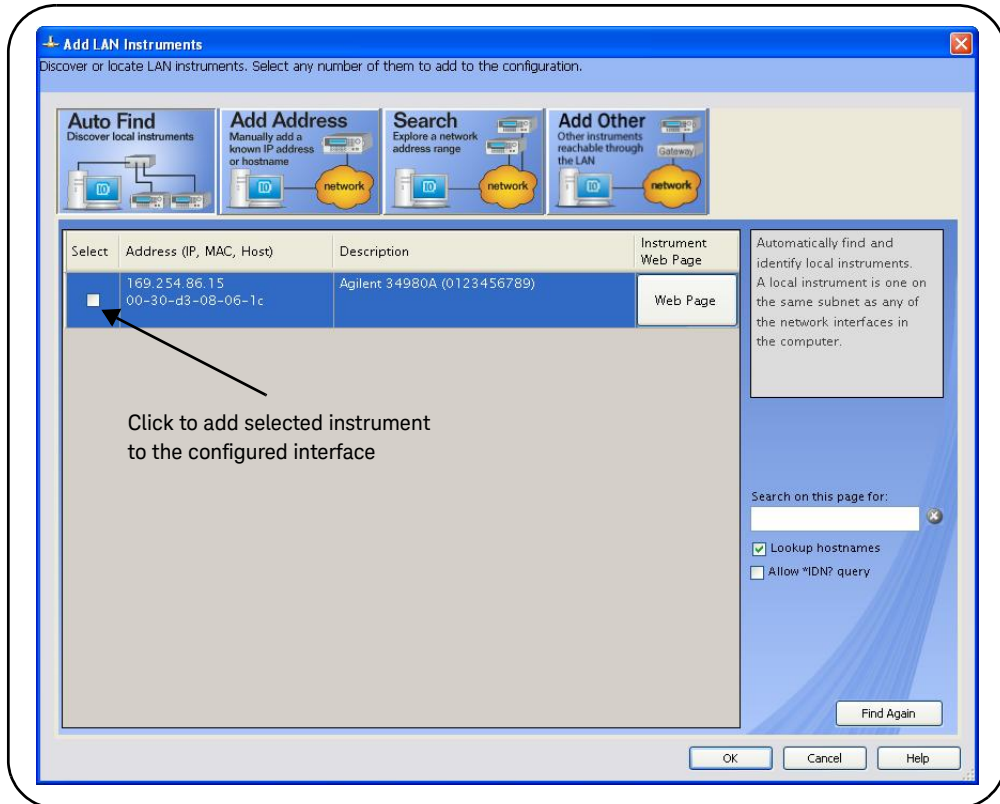

**Figure 3-3** Keysight Connection Expert “Add Instrument” Window.

After clicking ‘OK’, Keysight Connection Expert (version 15) performs an automatic find (search) of all instruments on the same subnet as the computer. An example of an instrument (34980A) found on a subnet is shown in Figure 3-5.

The “Add LAN Instruments” window identifies the instrument’s IP address, MAC address, host name, and product number. In the example of Figure 3-5, the instrument is connected to the PC via a LAN switch with no DHCP server present. Thus, the host name is not registered and access to the instrument is through its IP address.

“Select” the desired instruments from the list and then click ‘OK’. Communication paths to the instruments are verified and the instruments are added to the configured interface. The instruments appear in the Keysight Connection Expert Explorer pane (Figure 3-3). Selecting the instrument in the Explorer pane displays its properties in the Properties pane.



**Figure 3-4** Instruments Found on a Local Subnet.

### About IP Addresses and Host names

Dynamic Host Configuration Protocol (DHCP) and Automatic IP are enabled on the 34980A when shipped from Keysight. This allows the instrument to automatically obtain an address on the network. If there is a DHCP server on the network, the server will assign the address to the instrument.

If there is not a DHCP server on the network, the 34980A will automatically determine the address to use. The address will be in the range 169.254.1.1 to 169.254.255.255. If available, the instrument will try to acquire its default setting of 169.254.9.80.

**Host Names** The 34980A has a default host name. The format of the host name is:  
A-34980A-yyyyy

where 'yyyyy' are the last five digits of the instrument's serial number.

The instrument host name is reported by Keysight Connection Expert for network servers that support Dynamic Domain Name Service (DNS). For network servers that do not support Dynamic DNS, only the IP address is reported.

**Instrument Addressing** During programming, the 34980A/34945A is accessed through its address string which consists of an IP address:

TCPIP0::**169.254.86.15**::inst0::INSTR

or host name:

TCPIP0::**A-34980A-12345**.Keysight.com::inst0::INSTR

## LAN Default Configuration

If necessary, the 34980A LAN interface can be reset to its default configuration settings from the front panel. These settings are listed in Table 3-3.

**Table 3-3** Default LAN Configuration Settings.

LAN Parameter	Default (Reset) Setting
DHCP	ON
Automatic IP Addressing	ON
IP Settings if DHCP Server Unavailable	IP Address: 169.254.9.80 (default) Subnet Mask: 255.255.0.0 Default Gateway: 0.0.0.0
DNS Server	0.0.0.0 (may be assigned by the DHCP server)
Host Name (registered with DDNS if available)	A-34980A-last 5 digits of serial number
Net BIOS	ON
LAN Keep Alive	1800 (seconds)
Ethernet Connection Monitoring	ON - instrument monitors its LAN connection; will attempt to automatically reconnect if disconnected from network.
Password	None (disabled)

## Configuring the GPIB Interface

### NOTE

The following information assumes a GPIB interface card has been installed in your computer.

The 34980A is an Keysight web-enabled instrument that offers a user interface which requires no user-installed IO drivers. Access to the instrument via the Web interface, however, is only available through the LAN connection.

Programming access to the 34980A is also available through the instrument's optional GPIB interface. The GPIB connector is located on the rear panel of the instrument. Simultaneous LAN and GPIB connections to the instrument are allowed. The following information describes how instruments on the GPIB interface are configured using Keysight Connection Expert.

### GPIB Connections

GPIB cables can be connected to the PC in a “star” (all cables connect directly to the computer) or “linear” (instrument to instrument) configuration.

### Starting Keysight Connection Expert

Start Connection Expert by clicking the Keysight Control icon and selecting “Keysight Connection Expert” from the pop-up menu (Figure 3-2). If a GPIB card is installed in your computer, the (GPIB) interface was configured during installation of the Keysight IO libraries and is displayed in the left column (**Explorer** pane) of the “welcome” screen (Figure 3-6).

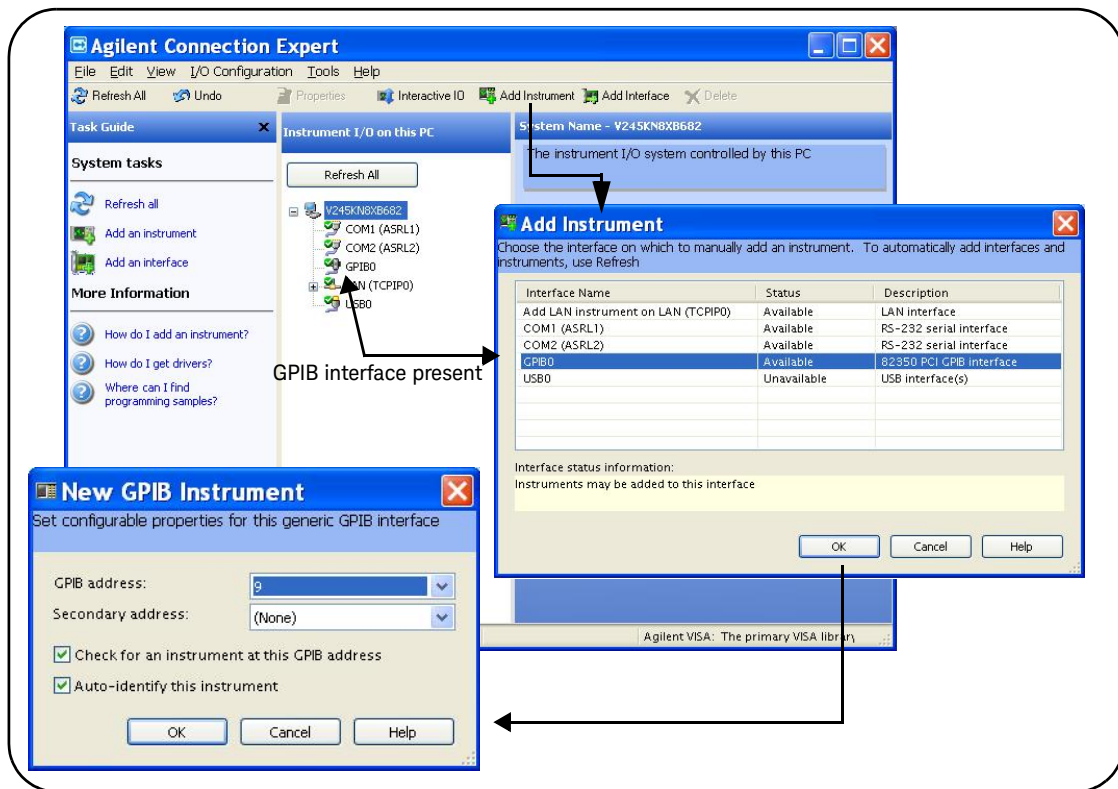

Figure 3-5 Adding Instruments to the GPIB Interface.

## Adding Instruments to the GPIB Configuration

In the Connect Expert window, select “Add Instrument” on the tool bar. Select the GPIB interface in the “Add Instrument” window and click ‘OK’ (Figure 3-6).

In the ‘New GPIB Instrument’ window, select the 34980A’s GPIB address (**note: factory-set address = 9**) and click ‘OK’.

Connection Expert will attempt to establish a communication path to the instrument. If the 34980A is at the address specified, the instrument will be added to the list of GPIB-configured instruments.

### NOTE

If the 34980A GPIB address is unknown, the address can be queried/set from the instrument front panel by: (1) pressing the ‘Utility’ key, (2) selecting the “Remote I/O” menu (‘Enter’ key), (3) selecting the ‘GPIB’ interface (control knob/‘Enter’ key), (4) enabling the GPIB interface (“Yes” - ‘Enter’ key).

## The GPIB Address String

When programming the 34980A/34945A over GPIB, the instrument’s GPIB address is included in the address string as shown below:

```
GPIB0:9::INSTR
```

## Changing the GPIB Address

The 34980A GPIB address can be changed from the front panel (see note above) or programmatically using the command:

**SYSTem:COMMunicate:GPIB:ADDRes < address >**

The command can be abbreviated by including only the upper-case letters in the command syntax. The command can be sent from the ‘Interactive IO’ window, or from the ‘SCPI Command Interface’ window - via a LAN connection.

When the address is changed, the new GPIB address IS NOT updated in Connection Expert if the instrument was previously configured.

From the Connection Expert window, highlight the instrument whose address was changed and then select ‘Change Properties ...’. Within the configurable properties window, change the address to the new address setting and select ‘OK’ (Figure 3-6).

## Configuring the USB Interface

The 34980A is a high-speed USB 2.0 device. Connection to the instrument is through the Type B USB connector located on the instrument rear panel.

### NOTE

The 34980A is an Keysight web-enabled instrument that offers a user interface which requires no user-installed IO drivers. Access to the instrument via the Web interface, however, is only available through the LAN connection.

---

### Adding Instruments to the USB Configuration

With the 34980A connected to the PC through the USB cable, start Keysight Connection Expert. The Connection Expert Utility should detect the 34980A on the USB interface (Figure 3-7). If not, Right-click the USB interface (USB0) and then select "Refresh This Interface".



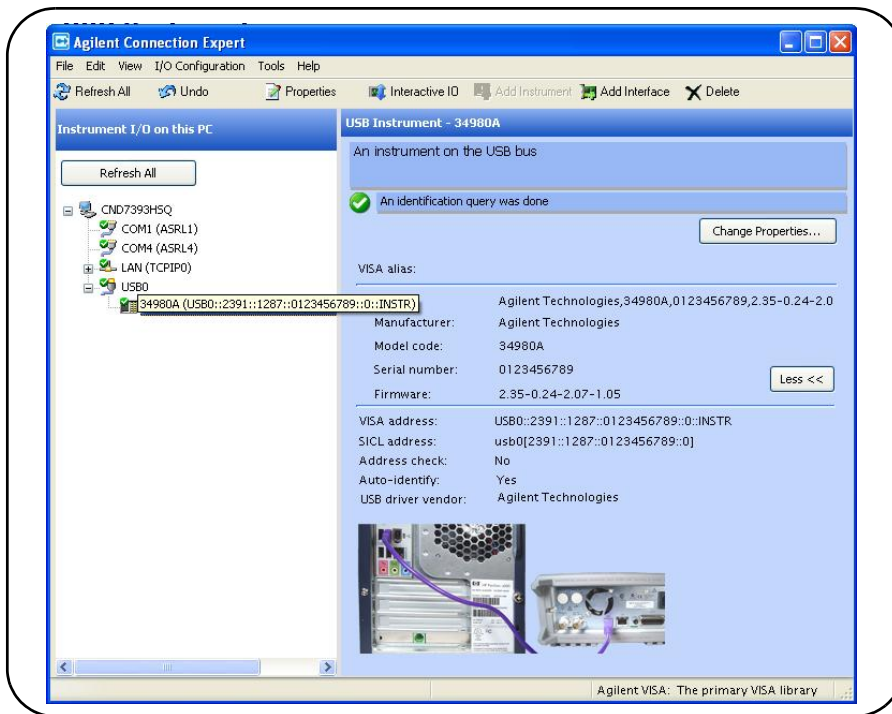

**Figure 3-6** The 34980A (34945A) Added to the USB Interface.

### The USB Address String

When programming the 34980A over USB, the instrument's USB address is included in the address string as shown below:

USB0::**2391**::**1287**::**0123456789**::**0**::INSTR

To simplify addressing during programming, a VISA alias can be assigned and used in place of the complete address. To assign an alias from Connection Expert, right-click on the USB-configured instrument and then select "Add VISA Alias". Enter the alias and then select 'OK' (Figure 3-8).

Once added, the alias appears under the complete address listed below the USB0 interface.

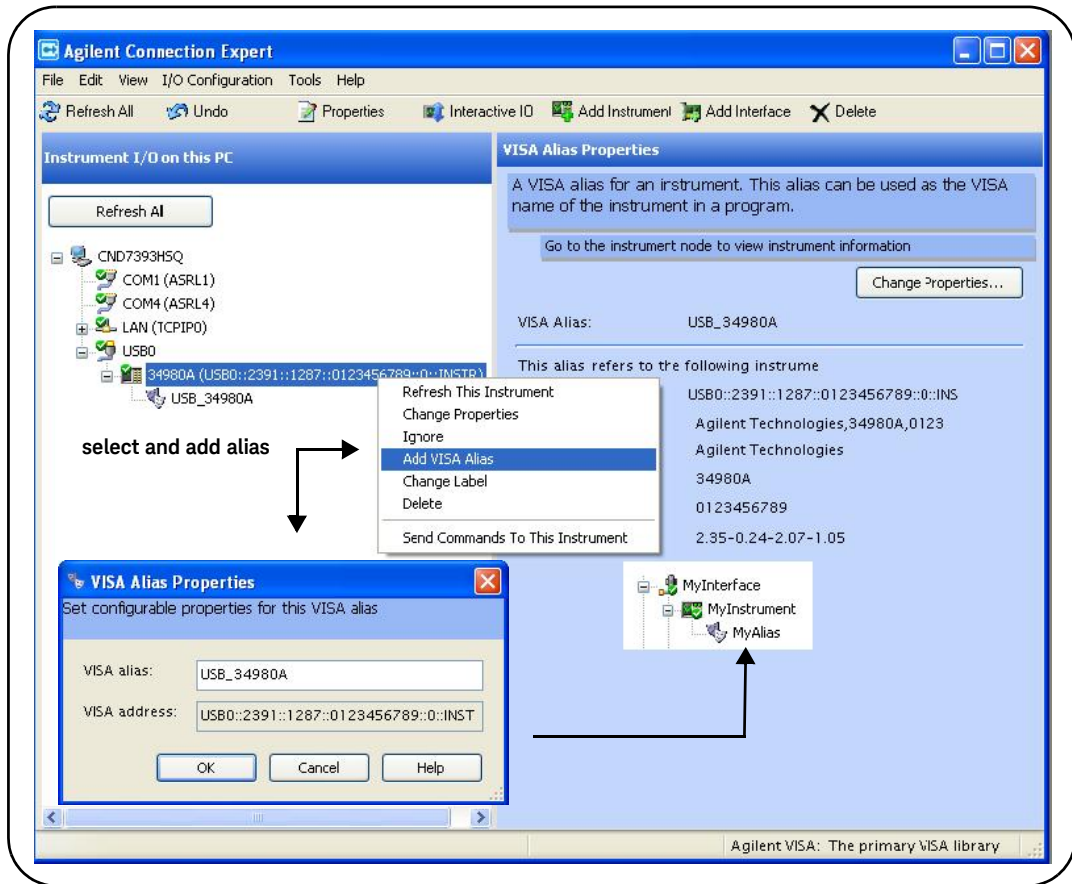

Figure 3-7 Adding a VISA Alias for the 34980A.

## The Web-Enabled Instrument Interface and Interactive IO

The Web-enabled instrument interface featured in Chapter 4 **is not available** from the **GPIB** or **USB** interface.

For GPIB or USB operation, the Connection Expert 'Interactive IO' utility can be used to send SCPI commands from the 34945A command set to the instrument. See the section "Using Interactive IO" for more information.

### Using Interactive IO

The Connection Expert 'Interactive IO' utility provides another method (Table 3-1) of sending commands to the 34945A. Similar to the 'SCPI Command Interface' window of the web-enabled interface, Interactive IO allows you to send any command in the 34945A SCPI command set to the instrument. Interactive IO can be used to:

- troubleshoot communication problems
- issue a "device clear"
- learn the instrument's command set
- prototype commands and verify (instrument) responses before writing code

Interactive IO is available via the instrument's LAN, GPIB, and USB interfaces. Figure 3-9 shows how Interactive IO is started from Connection Expert.

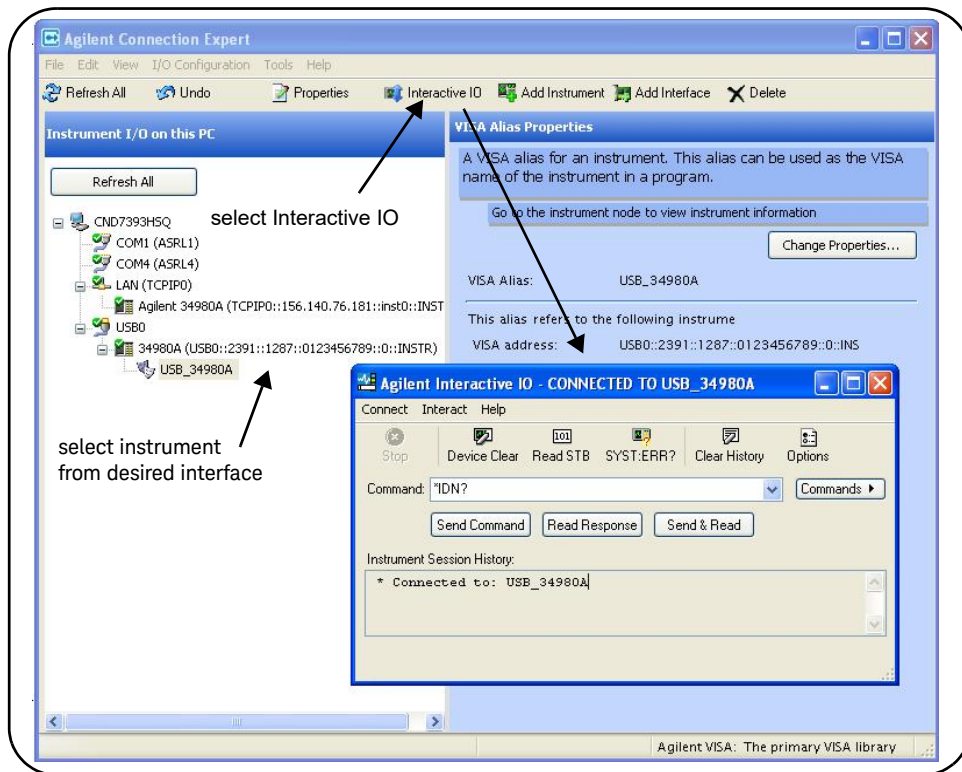

**Figure 3-8** Selecting an Instrument and Starting Interactive IO.

**NOTE**

If the Interactive IO window is used to send the self-test (\*TST?) command to the 34945A, the “timeout” period may have to be increased to allow the results to be returned. This is done using the ‘Options’ link on the Interactive IO window.

**NOTE**

For more information on Interactive IO, refer to the Keysight IO Libraries Suite Connectivity Guide. The guide is available on-line by clicking on the Keysight IO Control icon and then selecting Documentation -> Connectivity Guide.

## Firmware and Driver Updates

Firmware and driver updates (when available) for the 34980A are available via the Web. This section contains information for locating and downloading the updates to your computer, and then installing the updates in the instrument.

### Downloading and Installing the Update Utility

34945A firmware updates are installed in the instrument using the Keysight Firmware Update Utility. The utility and firmware update can be found on the Web at:

[www.Keysight.com/find/34980A](http://www.Keysight.com/find/34980A)

Once this page is displayed, highlight 'Technical Support' and from the Technical Support window select '**Drivers and Software**'. Within the drivers and software list, scroll to and select:

**34980A Firmware Update Revision <revision number>**

From this window, go to 'Documents and Downloads' and select:

**Keysight 34980A Firmware Update Utility**

When prompted, select 'Run' to install the utility. The default installation directory is C:\Program Files\Keysight\Firmware Update Utility. The utility will also be added to the 'start' menu under "Keysight".

### Downloading the Firmware Update

Return to the Web page and under "Documents & Downloads" and select:

**Keysight 34980A Firmware Revision <revision number>**

When prompted, select 'Run' to extract and download the file to your PC. Note the directory location as you will need to specify the path to the firmware file when you run the update utility.

#### NOTE

Depending on the interface to the 34945A, the firmware update utility will require the instrument's LAN, GPIB, or USB address. Note this address before starting the utility.

## Installing the Firmware Update

Updating the 34945A firmware includes updating firmware in the instrument (34980A/34945A) and in the 34945EXT module. The 34945EXT must be connected to the 34945A before starting the update procedure.

**NOTE**

For systems with multiple 34945EXT modules, this procedure must be repeated for **each** 34945EXT with the 34945EXT connected (one at a time) directly to the 34945A using D-sub cable part number 8121-1289 (see Figure 2-1).

- 1 From the installation directory or 'start' menu, start the utility and select 'Next' until the window shown in Figure 3-10 appears.
- 2 Using the 'Browse' button, specify the path to the firmware file. Once specified, the instrument model number will appear in the 'Applicable Model' window along with the revision and instrument description. Select 'Next'.

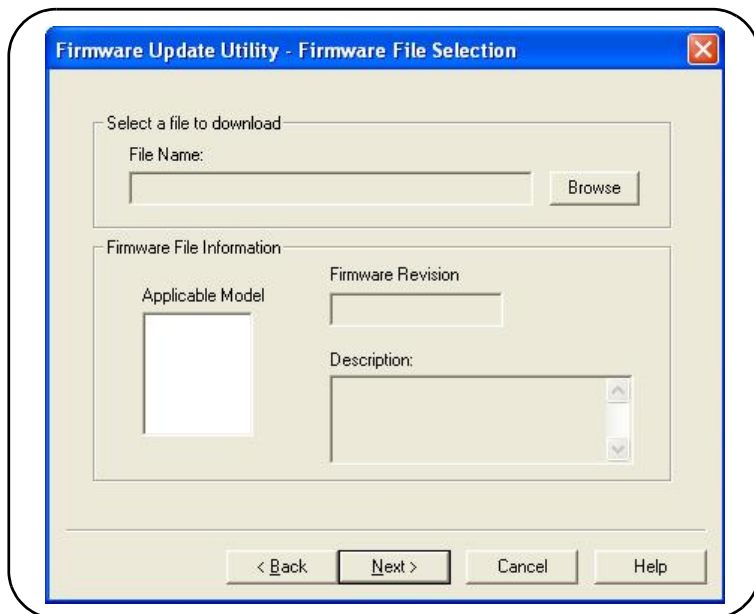
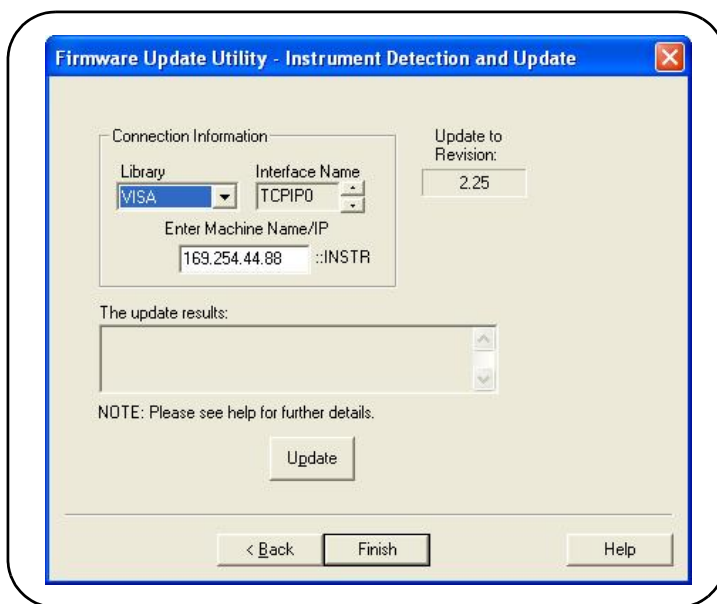

**Figure 3-9** Firmware Update Utility File Selection Window.

**NOTE**

The 'Applicable Model' window lists the instruments which may be updated by the specified firmware (.xs) image. The window is not used to select the instrument receiving the firmware update.

- 3 Select the I/O interface between the PC and the instrument and then select 'Next'. Enter the machine name/IP address, GPIB address, or USB address/alias as prompted (Figure 3-11). Select 'Update' to start the update process.



**Figure 3-10** Specifying the Instrument Address.

- 4 The update process takes several minutes to complete. The 34980A front panel will display "UPDATING FIRMWARE" during this time. DO NOT cycle power during the process.

Following the update the 34980A will reboot. Once the reboot sequence completes, cycle power. To view the revision number of the installed update from the 34980A front panel, press 'UTILITY' and rotate the front panel knob until 'SELECT MENU FIRMWARE' is displayed. Press 'ENTER' once and with "REVISIONS" highlighted, press 'ENTER' a second time. Rotating the knob will display the firmware revisions of the mainframe, front panel, DMM (if present), and installed modules (e.g. 34945A) by slot number.

To verify that the 34945EXT has the same firmware revision as the 34945A, the following commands can be sent from the Interactive IO utility within Keysight Configuration Expert:

```

SYSTem:CTYPe? <slot> !returns firmware revision of the 34945A
SYSTem:CTYPe:RMODule? (@<rem_ch>) [,<dist_board>] !returns firmware
                                                    revision of
                                                    the 34945EXT

```

For example, if the 34945A is installed in 34980A slot 2, **SYST:CYPE? 2** returns the serial number and firmware revision of the 34945A. Sending **SYST:CTYPE:RMOD? (@2100)** returns the serial number and firmware revision of the 34945EXT. The revision numbers must be the same.

#### NOTE

Following a firmware update, Keysight Connection Expert may report that the 34980A (34945A) configuration has changed. This is represented by a yellow triangle and an exclamation point (!) next to the updated instrument. Select the instrument name, select 'Change Properties', and then select either 'Test Connection' or 'Identify Instrument' to update Connection Expert.



## Downloading IVI-COM Driver and LabVIEW Driver Updates

IVI-COM and LabVIEW drivers for the 34980A (34945A) and the updates to these drivers can also be found on the Web at:

[www.Keysight.com/find/34980A](http://www.Keysight.com/find/34980A)

Once this page is displayed, highlight 'Technical Support' and from the Technical Support window select '**Drivers and Software**'. Within the drivers and software list, scroll to and select:

### **34980A Instrument Drivers**

From this window, go to '**Documents and Downloads**' where the driver updates are located.

THIS PAGE HAS BEEN INTENTIONALLY LEFT BLANK.

# 4 Introduction to Programming

Getting Started with the 34945A Web-Enabled Interface	101
System Verification	111
Switch and Attenuator Programming	116
Power-On, *RST, and SYSTem:CPON States	134

This chapter contains information on using the 34945A built-in Web interface for switch and attenuator control.

Refer to this chapter for specific information on:

- opening the instrument's Web interface
- the instrument's home Web page
- logging SCPI commands for transfer to other programming environments
- 34945A signal path verification
- using the Web interface to configure the 34945EXT and distribution boards, and to control channels
- using programming sequences
- power-on and reset settings

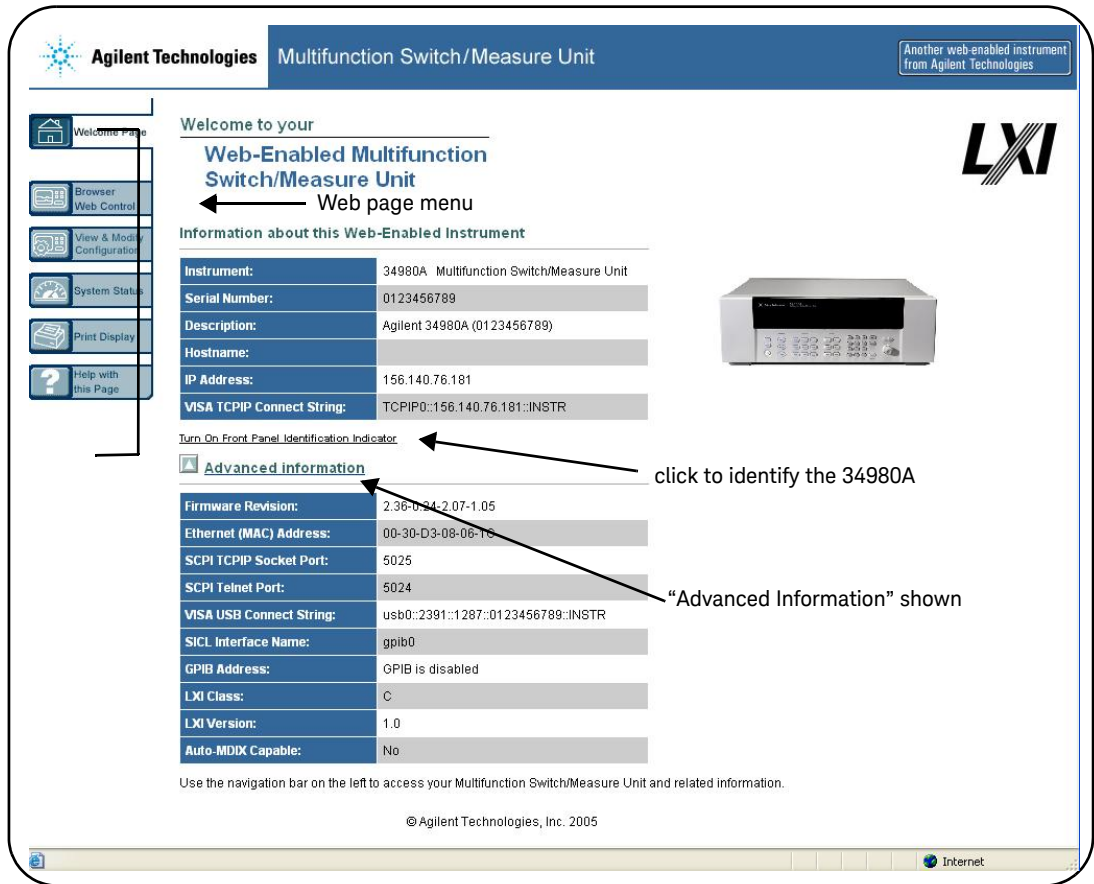

Figure 4-1 The 34980 (34945A) Programming Home Page.

## Getting Started with the 34945A Web-Enabled Interface

By far, the easiest way to begin programming the 34945A Microwave Switch/Attenuator Driver is through the instrument's built-in Web server. As mentioned in Chapter 3 (Table 3-1), the Web server's instrument interface requires a Java™-enabled Web browser, but no additional user-installed drivers or libraries. Full access to the instrument's functionality is available through the interface.

**NOTE**

This section describes the Web pages and windows primarily used to program the 34945A and 34945EXT modules. Refer to “Help with this Page” associated with each Web page for additional information on functions or pages not covered in this manual.

---

### Connecting to the Instrument and Viewing its Home Page

With the 34945A and 34945EXT(s) connected as shown in Figure 2-1, connect the 34980A to the PC using one of the LAN options shown. Note that a LAN cross-over cable is only required for a direct connection between the instrument and the PC, and only if the PC does not have Auto-MDIX (Gigabit Ethernet).

#### Obtaining the Host Name or IP Address

In order to connect a Web browser to the instrument, the 34980A host name or IP address is required. The host name set at the factory has the format:

A-34980A-yyyyy

where 'yyyyy' are the last five digits of the instrument's serial number. The serial number of the 34980A is located on the back of the instrument.

The 34980A IP address can be determined using 'Keysight Connection Expert' as described in the section “Adding Instruments to the Interface” in Chapter 3.

Start the computer's web browser and enter the host name or IP address in the browser's address window. The 34980A home page should appear as shown in Figure 4-1.

The instrument home page displays IO information, can be used to identify a connected instrument, and contains the menu tabs for accessing other Web pages and additional instrument functionality.

### An Overview of the 'Browser Web Control' Page

Configuration of the 34945A/34945EXT, distribution boards, and switch/attenuator channels occurs through the 'Browser Web Control' page. Clicking the 'Browser Web Control' tab on the home page opens the page shown in Figure 4-2.

The figure displays a composite screenshot of the Agilent 34945EXT software interface. At the top left is the 'System Overview' window, showing system and module information. To its right is the 'SCPI Command Interface' window. Below these is the main 'Multifunction Switch/Measure Unit' dashboard, which includes a 'Modules in Mainframe' section listing Slot 2 as 'uW Switch Driver [34945A]'. A 'View Remote Module' dropdown is set to '1'. The central 'Slot 2: Microwave Switch/Attenuator Driver' window shows a 'Channel Drives are OFF' status and a table of channels (Ch 2108 to Ch 2113) with their respective switches (SW 8 to SW 1). A 'bank diagram' label points to this table. To the right, the 'Remote Module 1 Configuration' window is open, showing 'Channel Drive' set to 'Off'. Below it, the 'Channel 2108 Configuration Information' window is open, showing 'Name' as 'SW 8' and 'Operation Mode' as 'Paired (SPDT)'. Arrows indicate the flow of information and configuration steps between these windows.

System Overview

SCPI Command Interface

SCPI command logging

SCPI programming interface

Agilent Technologies Multifunction Switch/Measure Unit

Another web-enabled instrument from Agilent Technologies

modules in mainframe

Slot 2: Microwave Switch/Attenuator Driver

View Remote Module 1

Channel Drives are OFF

Position Indicator

Configure Bank 1...

To Configure a channel, right-click near 'IsOpen' or 'IsClosed'

Position Indicator

SW 8

SW 7

SW 6

SW 5

SW 4

SW 3

SW 2

SW 1

Ch 2108

Ch 2107

Ch 2106

Ch 2105

Ch 2104

Ch 2103

Ch 2102

Ch 2101

Ch 2118

Ch 2117

Ch 2116

Ch 2115

Ch 2114

Ch 2113

Ch 2112

Ch 2111

bank diagram

switches per distribution board

distribution board installed

34945EXT configuration

Remote Module 1 Configuration

Channel Drive

Number of simultaneous channel operations allowed

Boot/Reset Channel Drive

Channel 2108 Configuration Information

Name

Operation Mode

Channel state after boot or Reset

Actuation Type

Pulse Width

Recovery Time

SettleTime

Verification

Verification Polarity

Figure 4-2 34945EXT, Distribution Board, and Channel Configuration.

### Observe Only / Allow Full Control

These settings disable/enable control of the 34945EXT from the Web interface. When 'Observe Only' is set, many of the features programmable from the dialog boxes (Configure Bank 1..., Configure Module..., etc.) are disabled.

### Viewing Remote Modules

Remote modules are the 34945EXT modules connected to the 34945A (Figure 2-1). 34945EXT modules are numbered according to their position in the daisy-chain sequence relative to the primary 34945EXT which is EXT number 1. The 34980A can support up to eight 34945EXT modules. The remote module currently selected is the one configured by the interface.

### Remote Module (34945EXT) Configuration Window

The remote module (34945EXT) configuration window provides settings that apply to all banks (i.e. distribution boards) on the EXT module.

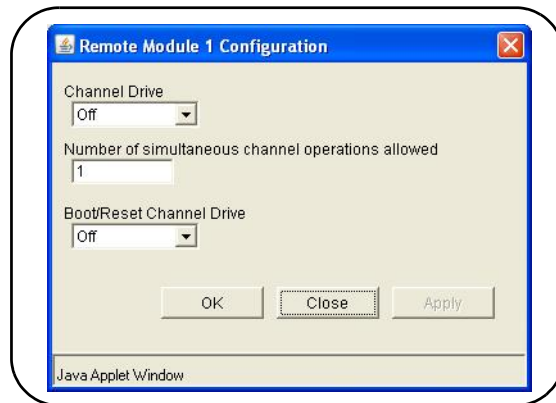

**Figure 4-3** The Remote Module Configuration Window.



These settings include:

- **channel drive source** - this is the source of the power supply for the EXT module. For the primary 34945EXT, valid sources are off, internal, and external. For all secondary 34945EXTs, valid sources are off and external. Note that the channel drive source must be off prior to configuring individual switches or attenuators (see “Switch/Attenuator Channel Configuration Window”).
- **number of simultaneous operations** - this sets the number of simultaneous channel activations (open/close) per command. For example, given a list of four channels and a specified number of four operations, a single open or close command will attempt to open/close all four channels simultaneously.  
  
This feature is limited to external channel drive sources (power supplies) with the capability to drive multiple channels.
- **boot/reset channel drive** - this parameter specifies the channel drive source setting following a re-boot (power-up) or reset of the instrument.

## Switch/Attenuator Channel Configuration Window

The switch/attenuator channel configuration window is opened by right-clicking near the ‘IsOpen’ or ‘IsClosed’ labels on the ‘programming diagram’.

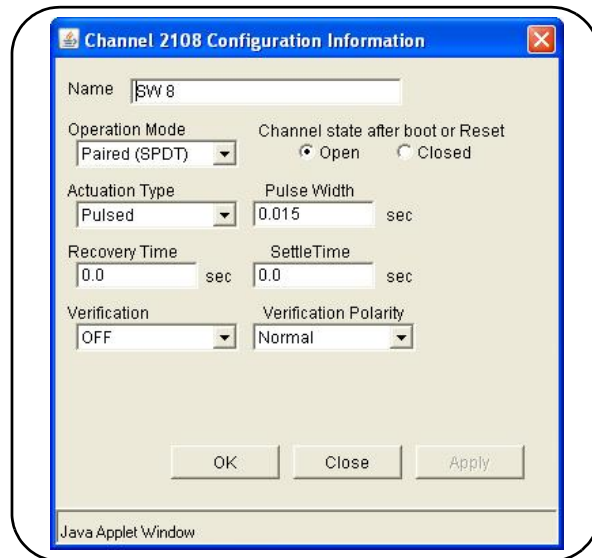

**Figure 4-4** The Switch/Attenuator Channel Configuration Window.

The configuration window applies to the **individual** channels on the distribution board. The parameters of this window include:

- **operation mode** - enables channel pairing for dual-coil devices.
- **channel state after boot or Reset** - specifies the channel state (opened, closed) following power-on or reset (assumes boot/reset channel drive state is set).
- **activation type** - specifies pulsed or continuous drive current.
- **pulse width** - specifies the pulse width of the drive current.
- **recovery time** - specifies the period between activation pulses
- **settle time** - specifies the time allowed for the switch/attenuator operation to complete.
- **verification** - enables and disables electronic verification of the programmed switch state.
- **verification polarity** - set the logic polarity of the expected switch position indicator signal.

### Bank (Distribution Board) Configuration Window

The distribution board bank configuration window provides settings for the **individual** banks on the 34945EXT.

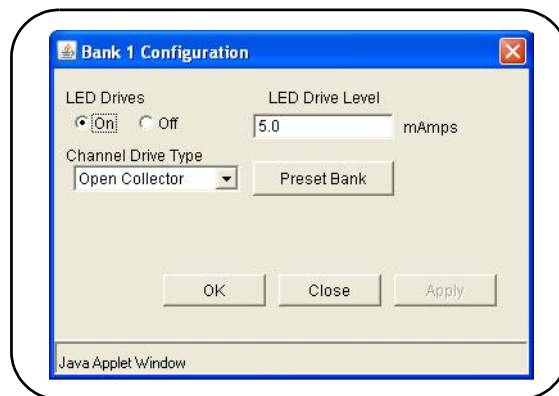

**Figure 4-5** The Bank (Distribution Board) Configuration Window.

These settings include:

- **LED drive control** - enables and disables the distribution board LED drives (LEDs not included) which reflect the position indicator states of the connected switches or attenuators.
- **LED drive level** - sets the amount of current which controls LED brightness.
- **channel drive type** - sets the current drive mode (TTL or Open Collector) for the specified channels.
- **Preset Bank** - this command sets the bank configuration to conform to the switches supported by the distribution board installed. **The programming of any switch or attenuator must begin by presetting the bank.**

## Legend

When enabled, channel verification [V] and pairing [P] (channel/attenuator configuration window) are indicated in the channel “bar”. Switch actuation is either continuous or pulsed. Pulsed operation is either open collector (falling edge) or TTL (rising edge).

## Bank Diagram

The Bank diagram provides direct switch control (open, close), and identifies channel numbering within the bank and switch status. The channel configuration can also be changed from the preset state as required.

**Position Indicator** The ‘Position Indicator’ column indicates the state of each switch after the position has been electronically verified. The Keysight switches and attenuators listed in Table 1-2 are latching relays and, therefore, there is a relay coil (channel) for each switch position.

**IsOpen/IsClosed** This indicator identifies which operation (open or close) was last selected using the channel’s ‘Open’ or ‘Close’ button on the programming diagram. It may not indicate the actual switch state as the switch position is not electronically verified.

## SCPI Command Interface

The SCPI programming interface window (Figures 4-2 and 4-6) enables you to send any command in the 34945A SCPI command set to the instrument.

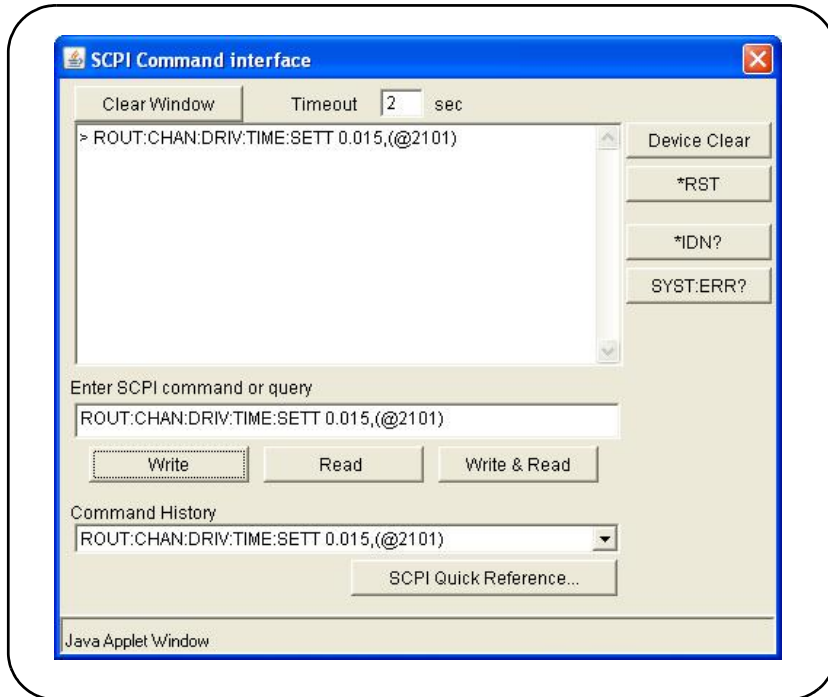

**Figure 4-6** Sending Commands from the SCPI Command Interface.

Once the command is entered, selecting 'Write' sends the command to the instrument. As mentioned before, commands sent from this interface are also logged (except query commands) and can be copied to other environments.

## Logging SCPI Commands

The System Overview window (Figures 4-2 and 4-7) is used to view SCPI commands sent to the instrument as it is configured using the windows of the 'Browser Web Control Page'. Once the desired configuration is set, the corresponding (logged) commands can be copied and pasted into other development environments.

Commands sent from any IO environment (e.g. Web windows, Keysight Connection Expert Interactive IO, Microsoft development environments) to the instrument are logged. **Query commands (those which return data) sent from any Web interface window are not logged.**

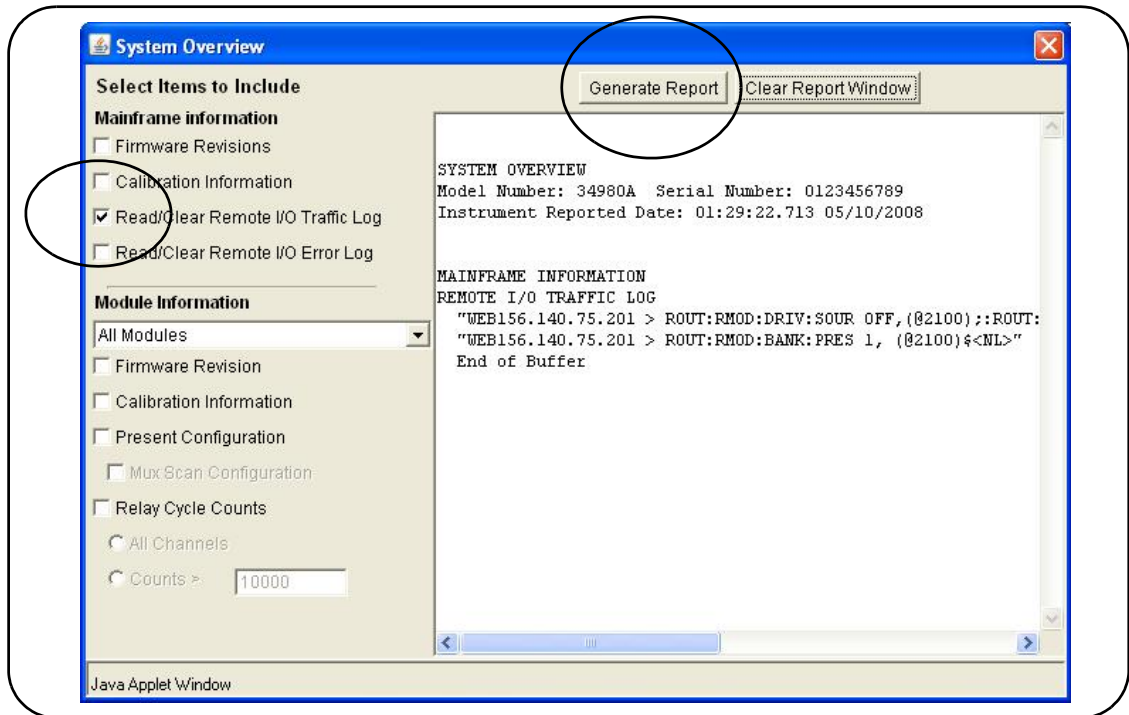

**Figure 4-7** Logging SCPI Commands within the System Overview Window.

To view commands, select “Read/Clear Remote I/O Traffic Log” and then select “Generate Report” **after** the desired configuration has been set. Logged commands are listed in the order received by the instrument. Commands may be listed individually or as part of a command string.

Note that when changing the 34945EXT module, bank, or channel configuration using the windows shown in Figure 4-2, **the SCPI commands associated with all parameters set by the given window are logged**. For example, changing the channel settling time to 15 ms using the bank 2 channel 1 configuration window causes the following string of commands to be logged and sent to the instrument (34945A is in 34980A slot 2):

```
ROUT:CHAN:LAB "SW 1", (@2121);:ROUT:CHAN:DRIV:PAIR:MODE ON,
(@2121);:ROUT:CHAN:VER:ENAB ON, (@2121);:ROUT:CHAN:VER:POL NORM,
(@2121);:ROUT:CHAN:DRIV:TIME:REC 0.0, (@2121);SETT 0.015,
(@2121);:ROUT:CHAN:DRIV:PULS:MODE ON, (@2121);WIDTH 0.015,
(@2121);:ROUT:CHAN:DRIV:OPEN:DEF (@2121)
```

If sent individually they would appear as:

```
ROUT:CHAN:LAB "SW 1", (@2121)
ROUT:CHAN:DRIV:PAIR:MODE ON, (@2121)
ROUT:CHAN:VER:ENAB ON, (@2121)
ROUT:CHAN:VER:POL NORM, (@2121)
ROUT:CHAN:DRIV:TIME:REC 0.0, (@2121)
ROUT:CHAN:DRIV:TIME:SETT 0.015, (@2121)
ROUT:CHAN:DRIV:PULS:MODE ON, (@2121)
ROUT:CHAN:DRIV:PULS:WIDTH 0.015, (@2121)
ROUT:CHAN:DRIV:OPEN:DEF (@2121)
```

Again, even though only one parameter (one command) was changed, each of the commands in the string above is sent to the instrument.

## System Verification

The most common defects associated with switches and attenuators connected to the 34945EXT through the Y1150A - Y1155A distribution boards are related to switch/attenuator cables.

The optional Y1156A Verification Board is used to provide visual confirmation of the signal path from the PC to distribution board banks 1-4 on the 34945EXT module. Verifying the signal to a selected bank can help isolate suspected problems in the path from the PC to the switch. The diagnostic board also verifies functioning of the electronic position indicator circuitry within the 34945EXT relative to position indicator signals received from the switch.

To begin using the 34945A Microwave Switch/Attenuator Driver as quickly as possible or to minimize troubleshooting, it is highly recommended that the path to each 34945EXT bank be verified prior to installing the distribution board and any switches or attenuators.

### Running the Verification Sequence

The verification sequence is executed from the 34945A Web interface. As mentioned in Chapter 3, the 34945A must be connected to the PC through one of the LAN configurations shown in Figure 2-1. The Web interface is not available from the GPIB or USB interface. To use the Verification Board:

- 1** Turn off the 34980A.
- 2** Install the verification board in bank 1 (or the desired bank) of the 34945EXT. Securely fasten the verification board within the bank using the terminal screws.
- 3** Turn on the 34980A and open the web interface. Select the 'Browser Web Control' page. See "Getting Started with the 34945A Web-Enabled Interface" for instructions on opening the Web page.
- 4** Select 'Allow Full Control' and in the 'Browser Web Control' window, locate the bank and Y1156A programming diagram. An example of the diagram is shown in Figure 4-8. For this example, the 34945A is installed in 34980A slot 2.

- 5 From the bank configuration window, select '**Preset Bank**'. It may be necessary to turn off the channel drive (module configuration window) before '**Preset Bank**' is active.
- 6 From the remote module configuration window, set the **Channel Drive** source to "Internal" or "External" depending on the 34945EXT supply and select '**Apply**'. The Y1156A is designed to use a +24V supply.
- 7 Click the "Create Verification Sequence" button. This button defines the verification sequence for the bank and opens the "Sequences..." window. With the defined sequence highlighted, select 'Execute Sequence' to start the sequence. The sequence will pass through the channel list three times. If the signal path to the bank and each channel is complete, the LEDs located on the board will illuminate as each channel in the list is closed.
- 8 Once the sequence completes, set the **Channel Drive** source to "Off". Move the Y1156A to the next bank. Click the "Update View" button located in the upper-right corner of the 'Browser Web Control' window to refresh the Web page with the new location of the Y1156A. Repeat steps 5-7 to test the signal path to the channels in the next bank.

**NOTE**

The "Create Verification Sequence" button that appears next to the Y1156 programming diagram is provided only when the Y1156A verification board is installed. The button does not appear with any other distribution board.

Once the verification sequence successfully completes, the sequence can be deleted. The (verification) sequence is defined for the bank each time the "Create Verification Sequence" button is selected.



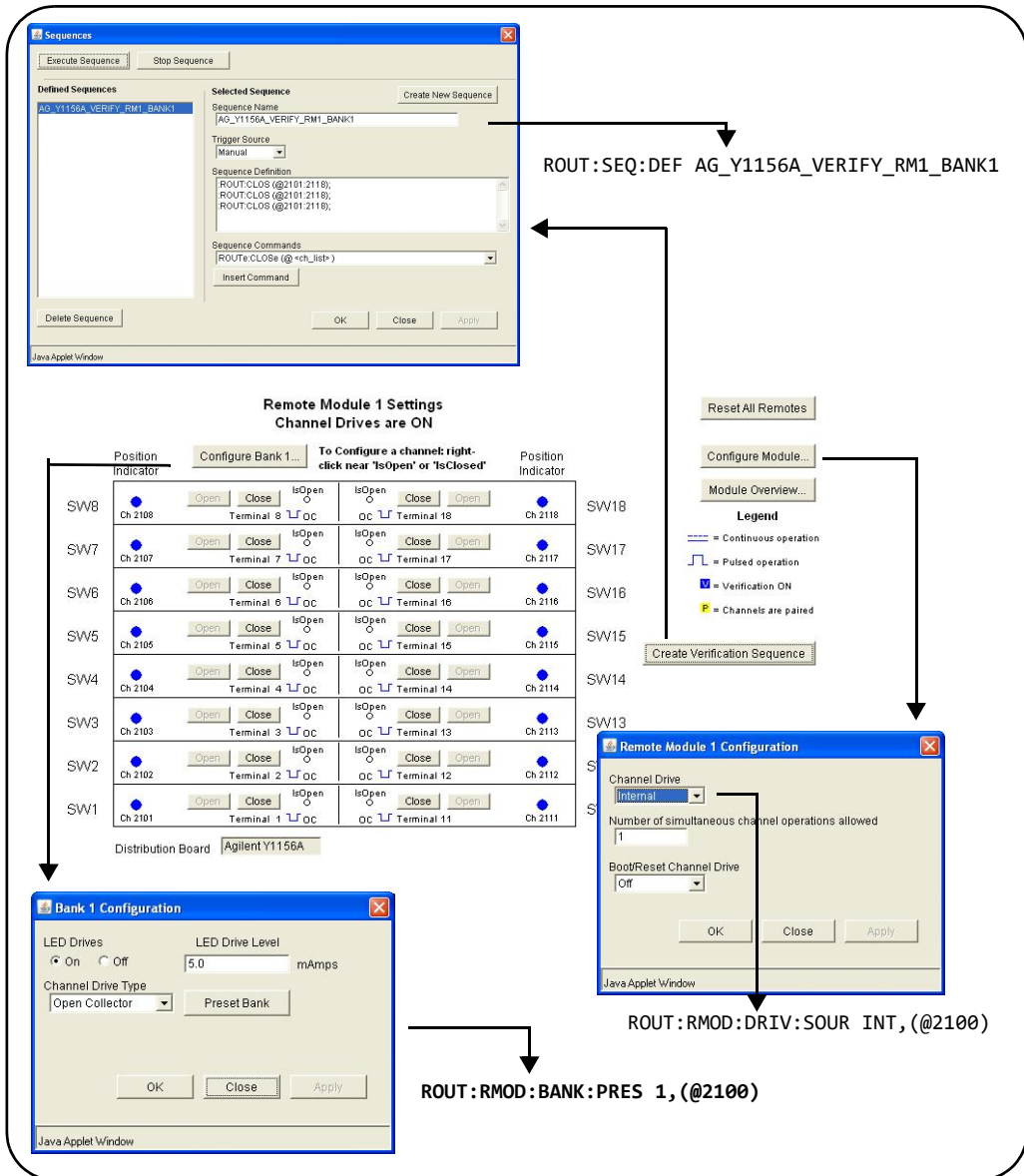

**Figure 4-8** Running the Y1156A Verification Sequence.

## Position Indicator Verification

Many Keysight switches contain position indicator options that allow for electronic verification of the switch position. The 34945EXT module contains circuitry to detect these signals and the Y1156A verification board can be used to test the functioning of this circuitry.

- 1 Turn off the channel drive (module configuration window) or turn off the 34980A.
- 2 Install the verification board in bank 1 (or the desired bank) of the 34945EXT. Securely fasten the verification board within the bank using the terminal screws.
- 3 Turn on the 34980A (if turned off) and open the web interface. Select the 'Browser Web Control' page and select 'Allow Full Control'.
- 4 In the 'Browser Web Control' window, locate the bank and Y1156A programming diagram. An example of the diagram is shown in Figure 4-9. For this example, the 34945A is installed in 34980A slot 1.
- 5 From the bank configuration window, select '**Preset Bank**' (the channel drive (module configuration window) must be off before '**Preset Bank**' is active).
- 6 Open the 'SCPI Command Interface' window (Figure 4-9) and from the window, send the commands:

```
ROUT:CHAN:VER:ENAB ON, (@1101:1118)      !enable verification
ROUT:CHAN:VER:POL INV, (@1101:1118)      !invert the polarity
ROUT:CHAN:DRIV:PULS:MODE OFF, (@1101:1118)!continuous drive
```

- 7 Create a verification sequence (see "Sequence Programming") that closes and opens the desired channel(s). Enable the channel drive and execute the sequence. With the polarity inverted (Step 6), closing the channel tests the 34945EXT circuitry receiving the position indication signal. An error message will occur if the position sensed does not correspond to the programmed state.
- 8 To verify other channels, modify the channel address in the sequence as required and execute the sequence again. To test another bank, set the **Channel Drive** source to "Off". Move the Y1156A to the bank and click the "Update View" button to refresh the Web page. Repeat steps 5-6 (with the new bank address) and change the channel addresses in the sequence.

**When finished, turn off the continuous current mode to prevent an overcurrent condition on the power supply driving the 34945EXT.**

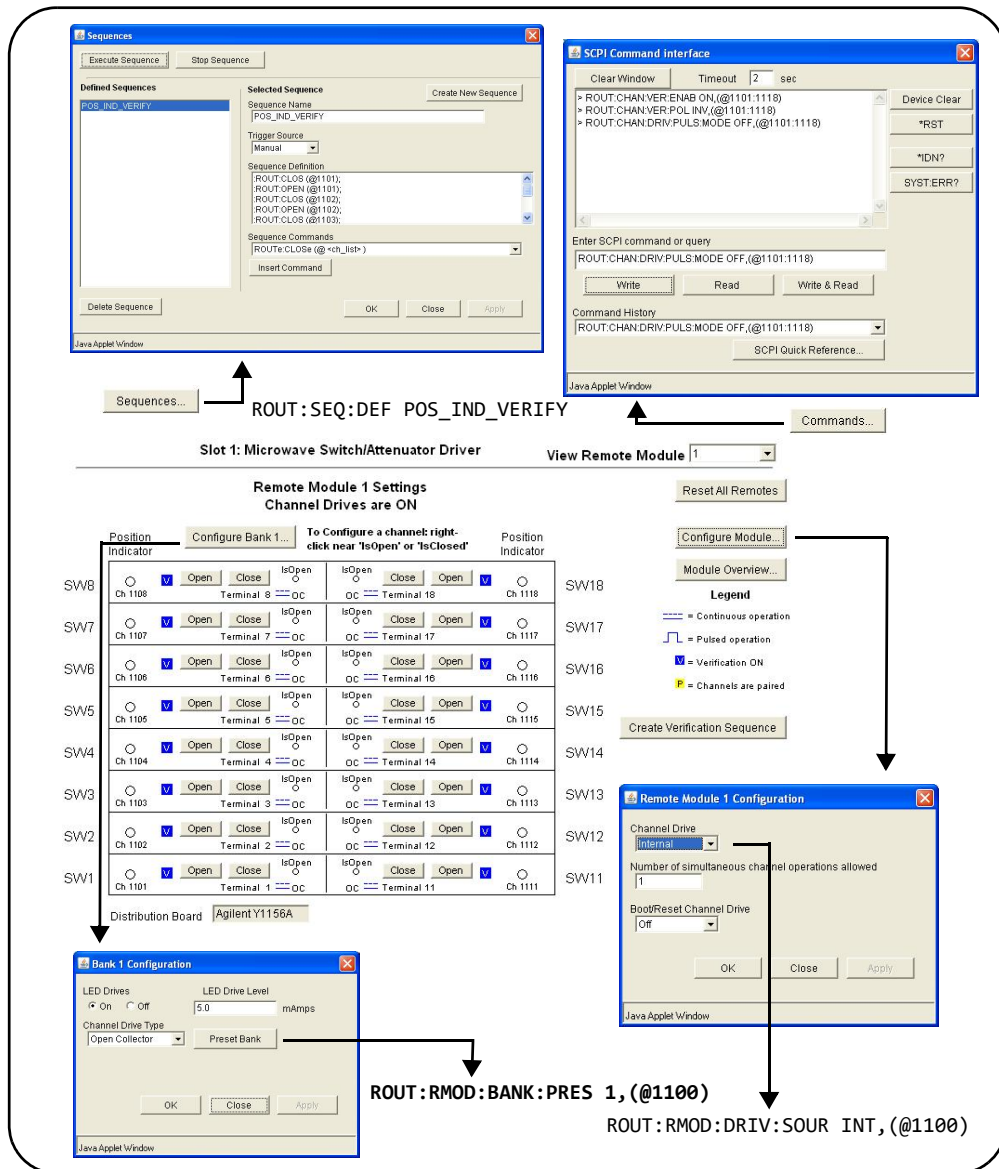

Figure 4-9 Using the Y1156A for Position Indicator Verification.

## Switch and Attenuator Programming

This section covers programming of switches/attenuators (Table 1-2) from the Web interface. The Web interface is used to demonstrate setting preset states that are optimized for the switches supported by the distribution boards.

**NOTE**

The information in this section does not cover the entire instrument command set. Refer to Chapter 5 for a complete list of instrument commands and to the Programmer's Reference which can be downloaded from [www.keysight.com/find/34980A](http://www.keysight.com/find/34980A) for detailed information.

---

### Keysight N1810/N1811/N1812 Series Switches

The Keysight N1810 / N1811 / N1812 series switches are supported on the following distribution board:

- Y1150A
  - N181x series (eight switches)

The bank diagram is shown in Figure 4-10 (the 34945A is in 34980A slot 1).

#### Presetting the Bank

In order to preset the banks on the 34945EXT module (the programming of any switch or attenuator must begin with the preset state), '**Allow Full Control**' (Figure 4-2) must be selected and the module's channel drive must be **off** (Configure Module... button).

To set the preset values for the N181x series switches (Figure 4-10), select '**Preset Bank**' in the Bank Configuration window. Presetting the bank is equivalent to sending the SCPI commands shown, or to configuring the switches to the settings indicated in the bank, module, and channel configuration windows.

## Changing Settings and Enabling the Channel Drive

Following the preset, use the bank configuration and channel configuration windows (Figure 4-10) to change the preset settings as required. The SCPI Command Interface window can also be used to send commands to the instrument.

When complete, use the module configuration window to enable the channel drive. (If using more than one 34945EXT, the channel drive source must be set to EXTERNAL for all 34945EXT modules other than the primary.) Use the bank diagram to control (open/close) the switches (see “Y1150A Switch Control” in Chapter 5 for more information).

**Settings (commands) from any of these sources can be logged for transfer to other programming environments (see “Logging SCPI Commands”).**

**Bank 1 Configuration**

LED Drives:  On  Off LED Drive Level: 5.0 mAmps

Channel Drive Type: Open Collector Preset Bank

OK Close Apply

Java Applet Window

**Remote Module 1 Settings**  
Channel Drives are OFF

**bank diagram**

Position Indicator: Configure Bank 1... To Configure a channel: right-click near 'IsOpen' or 'IsClosed'

Position Indicator	Channel	SW	IsOpen	IsClosed	Position Indicator
Ch 1108	Open	Close	IsOpen	IsClosed	Ch 1118
Ch 1107	Open	Close	IsOpen	IsClosed	Ch 1117
Ch 1106	Open	Close	IsOpen	IsClosed	Ch 1116
Ch 1105	Open	Close	IsOpen	IsClosed	Ch 1115
Ch 1104	Open	Close	IsOpen	IsClosed	Ch 1114
Ch 1103	Open	Close	IsOpen	IsClosed	Ch 1113
Ch 1102	Open	Close	IsOpen	IsClosed	Ch 1112
Ch 1101	Open	Close	IsOpen	IsClosed	Ch 1111

Distribution Board Agilent Y1150A

**Channel 1101 Configuration Information**

Name: SW 1

Operation Mode: Paired (SPDT) Channel state after boot or Reset:  Open  Closed

Actuation Type: Pulsed Pulse Width: 0.015 sec

Recovery Time: 0.0 sec Settle Time: 0.0 sec

Verification: OFF Verification Polarity: Normal

OK Close Apply

Java Applet Window

**Remote Module 1 Configuration**

Channel Drive: Off

Number of simultaneous channel operations allowed: 1

Boot/Reset Channel Drive: Off

OK Close Apply

Java Applet Window

**ROUT:RMOD:BANK: PRES 1, (@1100)**

ROUT:RMOD:BANK: LED:DRIV:ENAB ON,1, (@1100)  
 ROUT:RMOD:BANK: LED:DRIV:LEV 0.0050,1, (@1100)  
 ROUT:RMOD:BANK:DRIV:MODE OCOL,1, (@1100)

ROUT:RMOD:DRIV:SOUR OFF, (@1100)  
 ROUT:RMOD:DRIV:LIM 1, (@1100)  
 ROUT:RMOD:DRIV:SOUR:BOOT OFF, (@1100)

**Channel 1101 Configuration Information**

**ROUT:CHAN:LAB "SW 1", (@1101)**

ROUT:CHAN:DRIV:PAIR:MODE ON, (@1101)  
 ROUT:CHAN:DRIV:OPEN:DEF (@1101)  
 ROUT:CHAN:DRIV:PULS:MODE ON, (@1101)  
 ROUT:CHAN:DRIV:PULS:WIDTH 0.015, (@1101)  
 ROUT:CHAN:DRIV:TIME:REC 0.0, (@1101)  
 ROUT:CHAN:DRIV:TIME:SETT 0.0, (@1101)  
 ROUT:CHAN:VER:ENAB OFF, (@1101)  
 ROUT:CHAN:VER:POL NORM, (@1101)

**Figure 4-10** Y1150A Distribution Board Web User Interface Preset State.

## Keysight 87104/87106/87406 - L7104/L7106/L7204/L7206 Switches

The Keysight 87104/87106/87406 series and L7104/L7106/L7204/L7206 series switches are supported on the following distribution board:

- Y1151A
  - 87xxx series and L7xxx series (two switches)

The bank diagram is shown in Figure 4-11. In this example, the 34945A is in 34980A slot 1.

### Presetting the Bank

In order to preset any of the banks on the 34945EXT module (the programming of any switch or attenuator must begin with the preset state), **'Allow Full Control'** (Figure 4-2) must be selected and the module's channel drive must be **off** (Configure Module... button).

To set the preset values for the 87xxx and L7xxx series switches (Figure 4-11), select **'Preset Bank'** in the Bank Configuration window. All switches supported on this distribution board have the same preset settings. Presetting the bank is equivalent to sending the SCPI commands shown, or to configuring the switches to the settings indicated in the bank, module, and channel configuration windows.

### Changing Settings and Enabling the Channel Drive

Following the preset, use the bank configuration and channel configuration windows (Figure 4-11) to change the preset settings as required. The SCPI Command Interface window can also be used to send commands to the instrument.

When complete, use the module configuration window to enable the channel drive. (If using more than one 34945EXT, the channel drive source must be set to EXTERNAL for all 34945EXT modules other than the primary.) Use the bank diagram to control (open/close) the switches (see "Y1151A Switch Control" in Chapter 5 for more information).

**Settings (commands) from any of these sources can be logged for transfer to other programming environments (see "Logging SCPI Commands").**

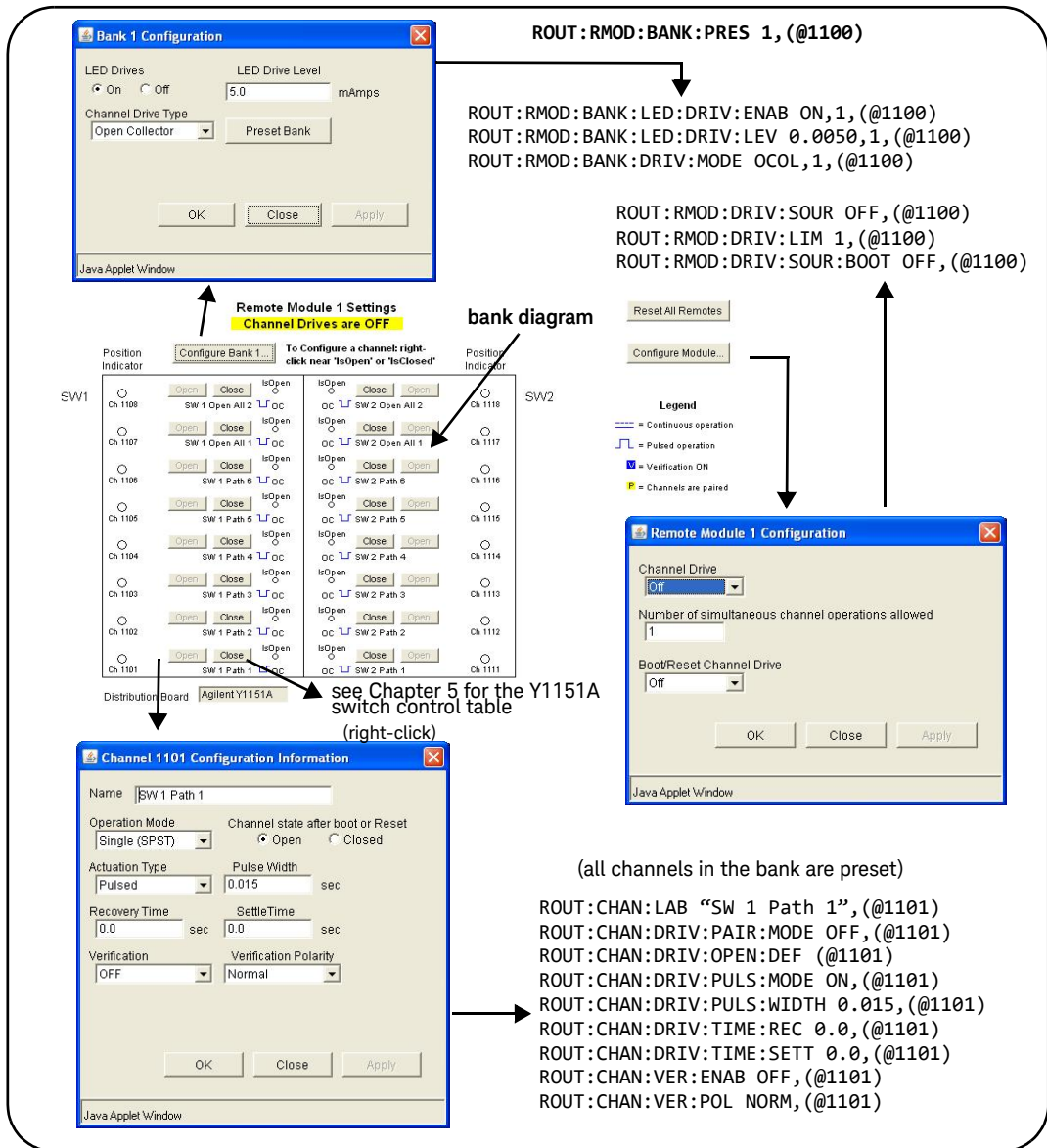

Figure 4-11 Y1151A Distribution Board Web User Interface Preset State.



## Keysight 87204 / 87206 Series and 87606 Switches

The Keysight 87204/87206 series and 87606 switches are supported on the following distribution board:

- Y1152A
  - 87204/87206 series and 87606 (one switch)
  - N181x series (two switches)

The bank diagram applies to both types of switches. The diagram is shown in Figure 4-12. In this example, the 34945A is in 34980A slot 1.

### Presetting the Bank

In order to preset any of the banks on the 34945EXT module (the programming of any switch or attenuator must begin with the preset state), **'Allow Full Control'** (Figure 4-2) must be selected and the module's channel drive must be **off** (Configure Module... button).

To set the preset values for the N181x series, the 872xx series, and 87606 switches (Figure 4-12), select **'Preset Bank'** in the Bank Configuration window. Presetting the bank is equivalent to sending the SCPI commands shown, or to configuring the switches to the settings indicated in the bank, module, and channel configuration windows.

### Changing Settings and Enabling the Channel Drive

Following the preset, use the bank configuration and channel configuration windows (Figure 4-12) to change the preset settings as required. The SCPI Command Interface window can also be used to send commands to the instrument.

When complete, use the module configuration window to enable the channel drive. (If using more than one 34945EXT, the channel drive source must be set to EXTERNAL for all 34945EXT modules other than the primary.) Use the bank diagram to control (open/close) the switches (see "Y1152A Switch Control" in Chapter 5 for more information).

**Settings (commands) from any of these sources can be logged for transfer to other programming environments (see "Logging SCPI Commands").**

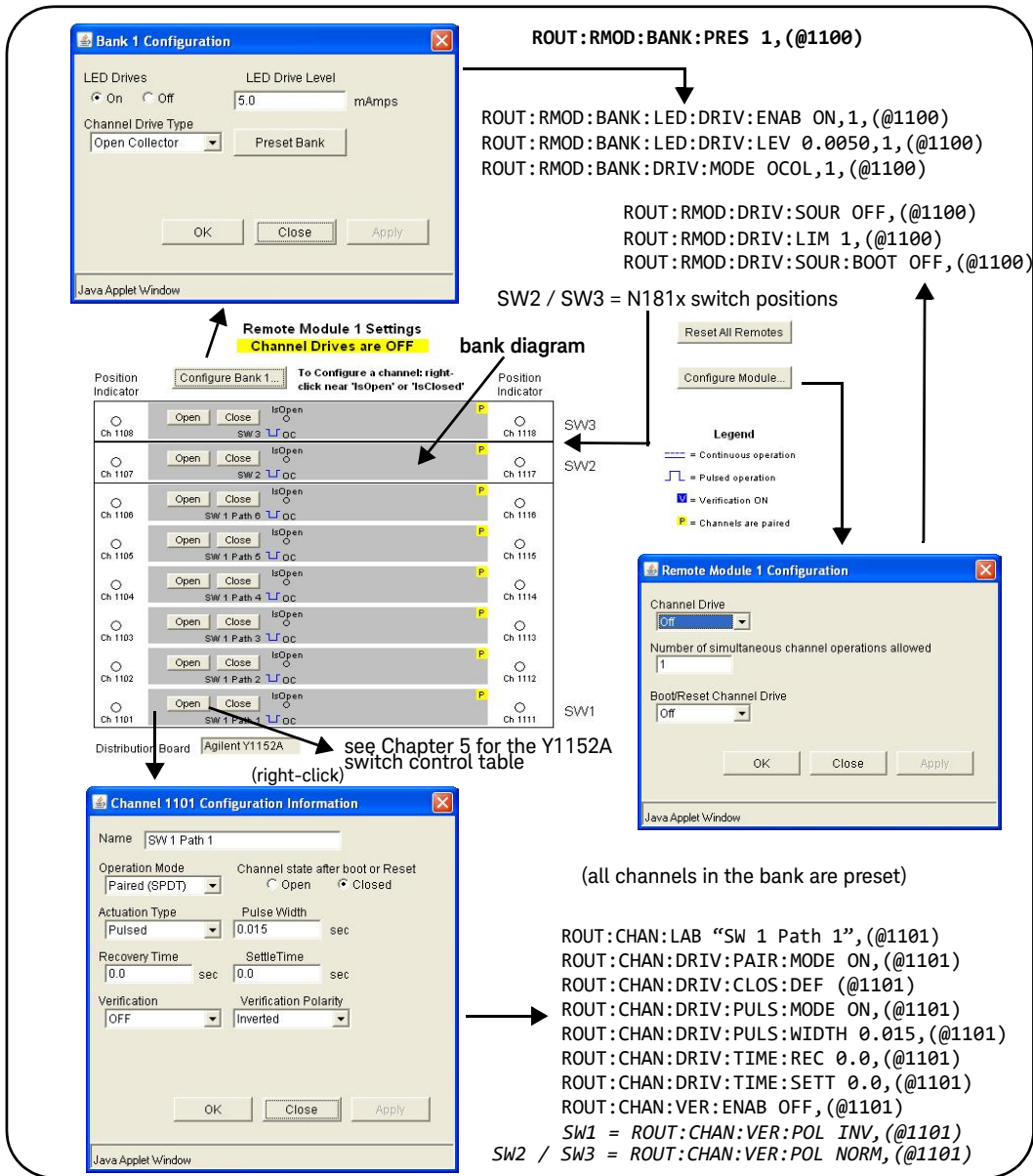

Figure 4-12 Y1152A Distribution Board Web User Interface Preset State.

## Keysight 8490x Series / 849x Series Attenuators and 876xM Series Switches

The Keysight 8490x series and 849x series attenuators, and the 876xM series switches are supported on the following distribution board:

- Y1153A
  - 8490x series (two attenuators - if no switch connected)
  - 849x series (two attenuators - if no switch connected)
  - 876xM series (two switches - if no attenuator connected - one 8769M)

The bank diagram shown in Figure 4-13 represents attenuators that have four sections of attenuation. See Figures 2-7 and 2-8 for attenuation guides. In this example, the 34945A is in 34980A slot 1.

### Presetting the Bank

In order to preset any of the banks on the 34945EXT module (the programming of any switch or attenuator must begin with the preset state), **'Allow Full Control'** (Figure 4-2) must be selected and the module's channel drive must be **off** (Configure Module... button).

To set the preset values for the 8490x series / 849x series attenuators and 876xM series switches (Figure 4-13), select **'Preset Bank'** in the Bank Configuration window. All attenuators supported on this distribution board have the same preset settings. Presetting the bank is equivalent to sending the SCPI commands shown, or to configuring the attenuators to the settings indicated in the bank, module, and channel configuration windows.

### Changing Settings and Enabling the Channel Drive

Following the preset, use the bank configuration and channel configuration windows (Figure 4-13) to change the preset settings as required. The SCPI Command Interface window can also be used to send commands to the instrument.

When complete, use the module configuration window to enable the channel drive. (If using more than one 34945EXT, the channel drive source must be set to EXternal for all 34945EXT modules other than the primary.) Use the bank diagram to control the levels of attenuation (see “Y1153A Switch Control” in Chapter 5 for more information).

**Settings (commands) from any of these sources can be logged for transfer to other programming environments (see “Logging SCPI Commands”).**

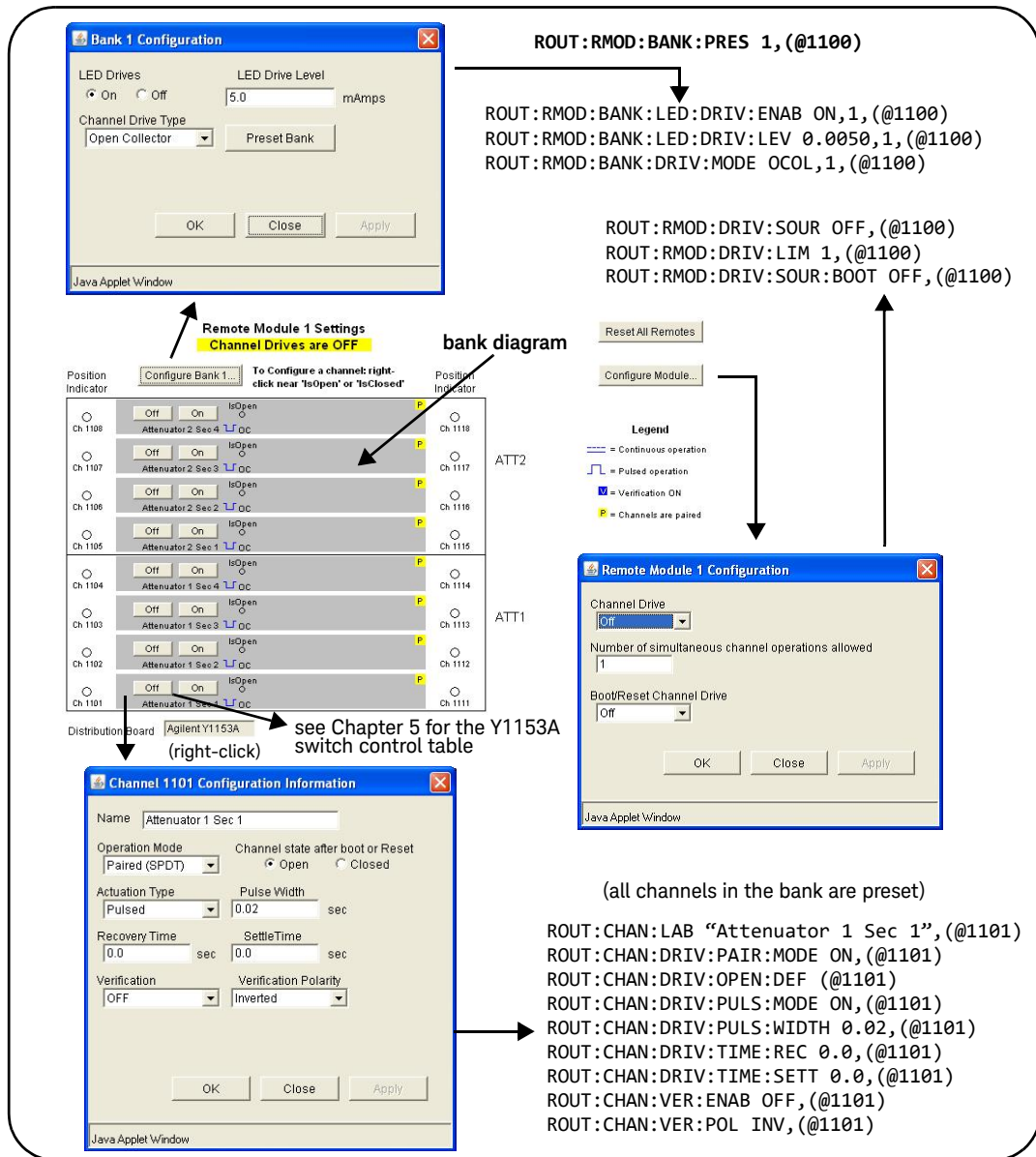

Figure 4-13 Y1153A Distribution Board Web User Interface Preset State.

## Keysight 87222 Series and L7222C Switches

The Keysight 87222 series and L7222C switches are supported on the following distribution board:

- Y1154A
  - 87222 series, L7222C (two switches)
  - N181x series (six switches)

The bank diagram applies to both types of switches and is shown in Figure 4-14. In this example, the 34945A is in 34980A slot 1.

### Presetting the Bank

In order to preset the banks on the 34945EXT module (the programming of any switch or attenuator must begin with the preset state), **'Allow Full Control'** (Figure 4-2) must be selected and the module's channel drive must be **off** (Configure Module... button).

To set the preset values for the 87222 series, the L7222C, and the N181x series switches (Figure 4-14), select **'Preset Bank'** in the Bank Configuration window. All switches supported on these distribution boards have the same preset settings. Presetting the bank is equivalent to sending the SCPI commands shown, or to configuring the switches to the settings indicated in the bank, module, and channel configuration windows.

## Changing Settings and Enabling the Channel Drive

Following the preset, use the bank configuration and channel configuration windows (Figure 4-14) to change the preset settings as required. The SCPI Command Interface window can also be used to send commands to the instrument.

When complete, use the module configuration window to enable the channel drive. (If using more than one 34945EXT, the channel drive source must be set to EXTERNAL for all 34945EXT modules other than the primary.) Use the bank diagram to control (open/close) the switches (see “Y1154A Switch Control” in Chapter 5 for more information).

**Settings (commands) from any of these sources can be logged for transfer to other programming environments (see “Logging SCPI Commands”).**

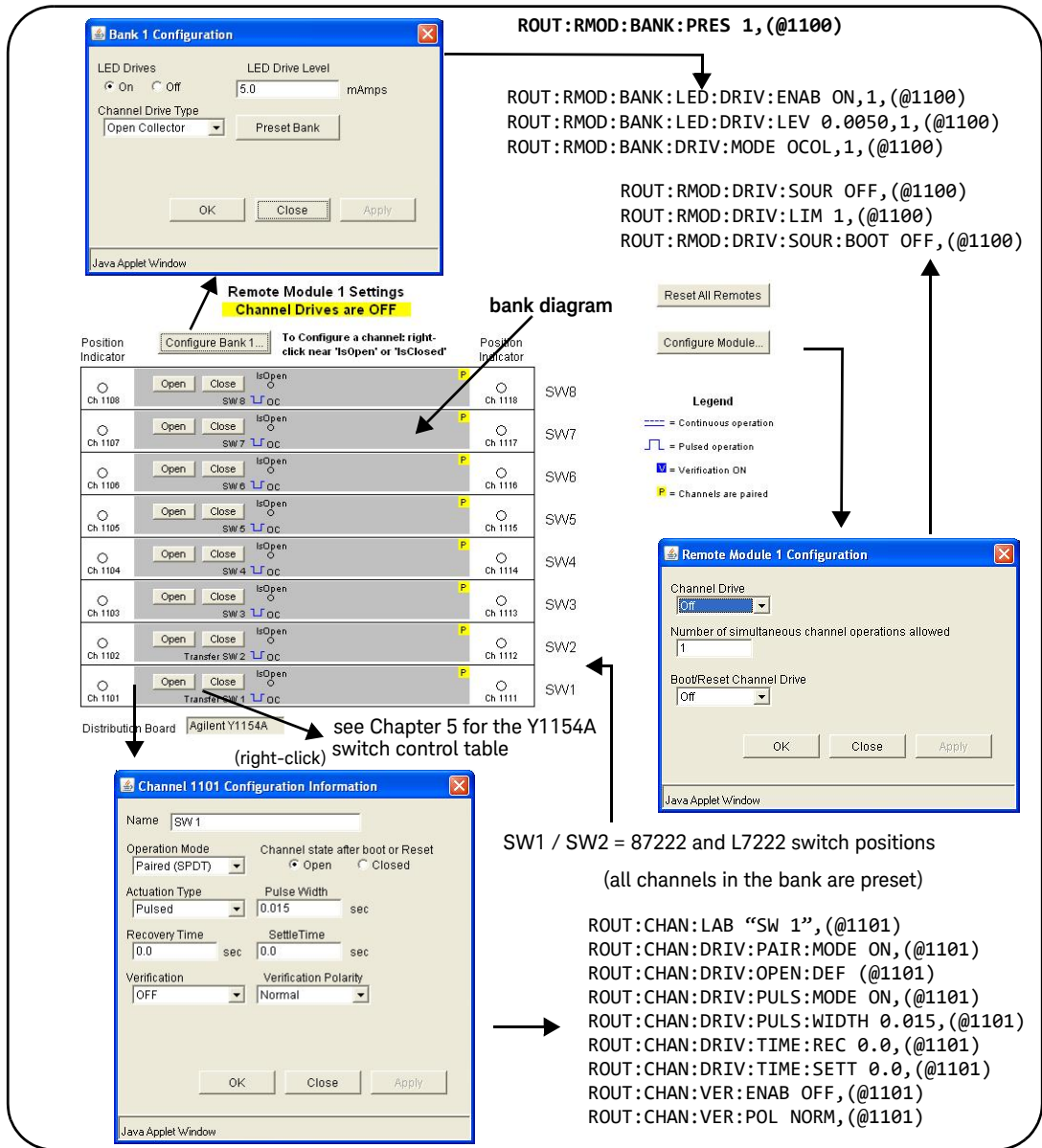

Figure 4-14 Y1154A Distribution Board Web User Interface Preset State.



## Keysight 876x Series and U9397A/C Switches

The Keysight 876x series and U9397A/C switches are supported on the following distribution board:

- Y1155A
  - 8762/8763/8764/8765 series (eight switches)
  - 8766/8767 K series (two switches)
  - 8768/8769 K series (one switch)
  - U9397A/C (sixteen switches)

The bank diagram applies to all series of switches. The diagram is shown in Figure 4-15. In this example, the 34945A is in 34980A slot 1.

### Presetting the Bank

In order to preset any of the banks on the 34945EXT module (the programming of any switch or attenuator must begin with the preset state), **'Allow Full Control'** (Figure 4-2) must be selected and the module's channel drive must be **off** (Configure Module... button).

To set the preset values for the 876x series and U9397A/C switches (Figure 4-15), select **'Preset Bank'** in the Bank Configuration window. All switches supported on this distribution board have the same preset settings. Presetting the bank is equivalent to sending the SCPI commands shown, or to configuring the switches to the settings indicated in the bank, module, and channel configuration windows.

### Changing Settings and Enabling the Channel Drive Source

Following the preset, use the bank configuration and channel configuration windows (Figure 4-15) to change the preset settings as required. The SCPI Command Interface window can also be used to send commands to the instrument.

When complete, use the module configuration window to enable the channel drive. (If using more than one 34945EXT, the channel drive source must be set to EXTERNAL for all 34945EXT modules other than the primary.) Use the bank diagram to control (open/close) the switches (see "Y1155A Switch Control" in Chapter 5 for more information).

**Settings (commands) from any of these sources can be logged for transfer to other programming environments (see "Logging SCPI Commands").**

### **Using other Keysight Switches with the Y1155A Distribution Board**

Any of the Keysight switches and attenuators listed in Table 1-2 can be used with the Y1155A distribution board. From the SCPI command Interface window, the preset settings for a given switch or attenuator can be set by sending the corresponding SCPI command for each preset value.

**Bank 1 Configuration**

LED Drives:  On  Off LED Drive Level: 5.0 mAmps

Channel Drive Type: Open Collector Preset Bank

OK Close Apply

Java Applet Window

**Remote Module 1 Settings**  
Channel Drives are OFF

**bank diagram**

Position Indicator: Configure Bank 1... To Configure a channel: right-click near 'IsOpen' or 'IsClosed'

SW8	Ch 1108	Open	Close	IsOpen	IsOpen	Close	Close	Ch 1118	SW18
SW7	Ch 1107	Open	Close	IsOpen	IsOpen	Close	Close	Ch 1117	SW17
SW6	Ch 1106	Open	Close	IsOpen	IsOpen	Close	Close	Ch 1116	SW16
SW5	Ch 1105	Open	Close	IsOpen	IsOpen	Close	Close	Ch 1115	SW15
SW4	Ch 1104	Open	Close	IsOpen	IsOpen	Close	Close	Ch 1114	SW14
SW3	Ch 1103	Open	Close	IsOpen	IsOpen	Close	Close	Ch 1113	SW13
SW2	Ch 1102	Open	Close	IsOpen	IsOpen	Close	Close	Ch 1112	SW12
SW1	Ch 1101	Open	Close	IsOpen	IsOpen	Close	Close	Ch 1111	SW11

Distribution Board Agilent Y1155A

see Chapter 5 for the Y1155A (right-click) switch control tables

**Channel 1101 Configuration Information**

Name: Screw Terminal 1

Operation Mode: Single (SPST) Channel state after boot or Reset:  Open  Closed

Actuation Type: Pulsed Pulse Width: 0.015 sec

Recovery Time: 0.0 sec Settle Time: 0.0 sec

Verification: OFF Verification Polarity: Normal

OK Close Apply

Java Applet Window

**Remote Module 1 Configuration**

Channel Drive: Off

Number of simultaneous channel operations allowed: 1

Boot/Reset Channel Drive: Off

OK Close Apply

Java Applet Window

**ROUT:RMOD:BANK:PRES 1, (@1100)**

ROUT:RMOD:BANK:LED:DRIV:ENAB ON,1, (@1100)  
 ROUT:RMOD:BANK:LED:DRIV:LEV 0.0050,1, (@1100)  
 ROUT:RMOD:BANK:DRIV:MODE OCOL,1, (@1100)  
 U9397A -> ROUT:RMOD:BANK:DRIV:MODE TTL,1, (@1100)

ROUT:RMOD:DRIV:SOUR OFF, (@1100)  
 ROUT:RMOD:DRIV:LIM 1, (@1100)  
 ROUT:RMOD:DRIV:SOUR:BOOT OFF, (@1100)

**Legend**

- Continuous operation
- Pulsed operation
- Verification ON
- Channels are paired

**ROUT:CHAN:LAB "Screw Terminal 1", (@1101)**

ROUT:CHAN:DRIV:PAIR:MODE OFF, (@1101)  
 ROUT:CHAN:DRIV:OPEN:DEF (@1101)  
 ROUT:CHAN:DRIV:PULS:MODE ON, (@1101)  
 ROUT:CHAN:DRIV:PULS:WIDTH 0.015, (@1101)  
 ROUT:CHAN:DRIV:TIME:REC 0.0, (@1101)  
 ROUT:CHAN:DRIV:TIME:SETT 0.0, (@1101)  
 ROUT:CHAN:VER:ENAB OFF, (@1101)  
 ROUT:CHAN:VER:POL NORM, (@1101)

For 876x series, these must be set as:

ROUT:CHAN:DRIV:PAIR:MODE ON, (@1101)  
 ROUT:CHAN:VER:POL INV, (@1101)

U9397A/C -> ROUT:CHAN:DRIV:PULS:MODE OFF, (@1101)

Figure 4-15 Y1155A Distribution Board Web User Interface Preset State.

## Sequence Programming

A programming sequence is a set of commands that provide direct control (open, close, delay) of switches and attenuators. The advantages of using programming sequences are:

- a sequence can be given a descriptive name indicating its function or the signal path it is controlling
- programming speed is increased (IO - input/output transactions decreased)
- channel operations (delay/open/close) occur precisely and in the channel list order specified

A programming sequence can be defined using the Sequences window opened with the **Sequences...** button on the 'Browser Web Control' page (Figure 4-2). The Sequences window is shown in Figure 4-16.

### Defining a Sequence

Sequences are defined by a sequence name, trigger source, and definition (the commands within the sequence). The commands allowed **within** a 34945A sequence are limited to those listed in the 'Sequence Commands' drop-down box and include:

```

ROUTE:CLOSE (@<ch_list>)
ROUTE:OPEN (@<ch_list>)
ROUTE:MODULE:WAIT <slot>|ALL
ROUTE:SEQUENCE:TRIGGER[:IMMEDIATE] <sequence_name>
SYSTEM:DELAY[:IMMEDIATE] <time_in_seconds>
ABORT

```

Additional guidelines when using sequences include:

- 1 Sequences are stored in the non-volatile memory of the 34945EXT.
- 2 Up to 500 sequences can be stored; each sequence must be  $\leq$  1024 bytes.
- 3 Sequences can be nested (one sequence can start another).
- 4 Sequences are not deleted with **SYSTEM:RMODULE:RESET**
- 5 Renaming a sequence creates a new sequence by that name.
- 6 Defined sequences can be logged for transfer to other programming environments (see "An Overview of the 'Browser Web Control' Page").

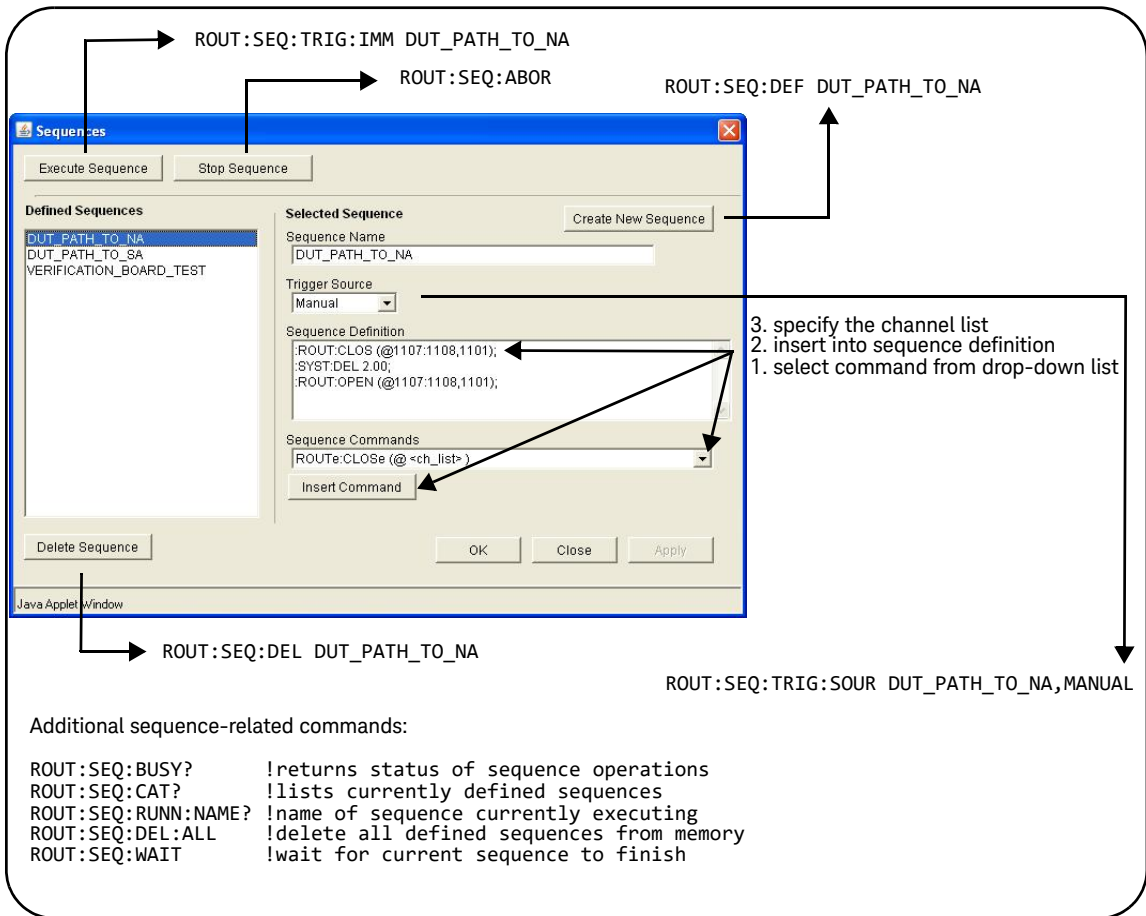

**Figure 4-16** Defining Programming Sequences with the Sequences Window.

## Power-On, \*RST, and SYSTem:CPON States

Cycling power or resetting the 34945A (\*RST, SYSTem:CPON commands) restores user-specified default states, but otherwise maintains preset or individually-set switch or attenuator settings. The default states restored are those specified with the commands:

```
ROUTe:CHANnel:DRIVE:CLOSe:DEFault !channel settings
```

```
ROUTe:CHANnel:DRIVE:OPEN:DEFault
```

```
ROUTE:RMODule:DRIVE:SOURce:BOOT !drive current-ON, OFF,
EXTernal
```

All other switch/attenuator settings in place prior to the power cycle or reset event remain unchanged. These events, however, do cause the 34945EXT to recognize new topologies (external switches, power configurations).

### NOTE

If a channel is configured for a single drive in pulsed mode, OPEN operations are undefined. When these channels are configured to a default state of OPEN, no action is taken on these channels.

### The Web Interface 'Reset All Remotes' Button

The '**Reset All Remotes**' button located to the right of the switch or attenuator (Web interface) programming diagram resets all distribution board settings on all attached 34945EXT modules to their user-specified default states, preset settings, and individually-set switch or attenuator settings. This button is equivalent to the SCPI command:

```
SYSTem:CPON <s1ot>
```

<s1ot> is the 34980A slot where the selected 34945A is installed.

## Restoring 34945A Factory Settings

Factory settings for the 34945A, all attached 34945EXT modules, and all installed distribution boards are restored with the command:

```
SYSTEM:RMOdule:RESet <slot>
```

<slot> is the 34980A slot where the selected 34945A is installed. This command and its subsequent settings override any previously stored preset, default, and power-on or reset settings. The factory settings grouped according to 34945EXT, bank, and channel are shown in Table 4-1.

**Table 4-1** 34945A Factory Settings.

Parameter	Command	Setting
<b>34945EXT Settings</b>		
Channel Drive Source	ROUTe:RMOdule:DRIVe:SOURce:IMMediate	OFF
Boot/Reset Channel Drive	ROUTe:RMOdule:DRIVe:SOURce:BOOT	OFF
Simultaneous Operations	ROUTe:RMOdule:DRIVe:LIMit	1
<b>Bank Settings</b>		
Channel Drive Type	ROUTe:RMOdule:BANK:DRIVe:MODE	OCOLlector
LED Drives	ROUTe:RMOdule:BANK:LED:DRIVe:ENABle	ON
LED Drive Level	ROUTe:RMOdule:BANK:LED:DRIVe:LEVel	5 mA
<b>Channel Settings</b>		
Operation Mode	ROUTe:CHANnel:DRIVe:PAIRed:MODE	OFF
Actuation Type	ROUTe:CHANnel:DRIVe:PULSe:MODE	ON
Pulse Width	ROUTe:CHANnel:DRIVe:PULSe:WIDTh	15 ms
Recovery Time	ROUTe:CHANnel:DRIVe:TIME:RECOvery	0.0 seconds
Settle Time	ROUTe:CHANnel:DRIVe:TIME:SETTle	0.0 seconds
Channel State (after boot or reset)	ROUTe:CHANnel:DRIVe:OPEN:DEFault	OPEN
Verification	ROUTe:CHANnel:VERify:ENABle	OFF
Verification Polarity	ROUTe:CHANnel:VERify:POLarity	NORMAl

THIS PAGE HAS BEEN INTENTIONALLY LEFT BLANK.



# 5 Additional Operating Information

34945A SCPI Command Summary	138
Y1150A - Y1155A Switch Control Tables	144
Drive Modes	152
Using Single-Coil Switches and Attenuators	153
Using Dual-Coil Switches and Attenuators	156
Overcurrent Conditions	163
Command Execution Times	164
Verifying Switch States	165
LED Drive Indicators	167

This chapter contains additional information on selected topics covered in Chapters 1-4. Refer to this chapter for specific information on:

- the 34945A command summary
- switch control tables
- open collector (OC) and TTL drive modes
- single- and dual-coil switches and attenuators
- continuous vs. pulsed drive modes
- overcurrent conditions
- factors related to command execution times

## 34945A SCPI Command Summary

Table 5-1 lists the SCPI commands that apply to the 34945A RF Switch Platform.

As not all commands are covered in this manual, refer to the Programmer's Reference which can be downloaded from [www.keysight.com/find/34980A](http://www.keysight.com/find/34980A) for detailed information on the complete SCPI command set.

**Table 5-1** 34945A SCPI Command Summary.

Subsystem	Commands
<b>ROUTE</b> (Switch Control)	ROUTE:CHANnel:DRive:CLoSe:DEFault (@<ch_list>)
	ROUTE:CHANnel:DRive:CLoSe:DEFault? (@<ch_list>)
	ROUTE:CHANnel:DRive:OPen:DEFault (@<ch_list>)
	ROUTE:CHANnel:DRive:OPen:DEFault? (@<ch_list>)
	ROUTE:CHANnel:DRive:PAIRed[:MODE] {OFF 0 ON 1}, (@<ch_list>)
	ROUTE:CHANnel:DRive:PAIRed[:MODE]? (@<ch_list>)
	ROUTE:CHANnel:DRive:PULSe[:MODE] {OFF 0 ON 1}, (@<ch_list>)
	ROUTE:CHANnel:DRive:PULSe[:MODE]? (@<ch_list>)
	ROUTE:CHANnel:DRive:PULSe:WIDTh {<seconds> MIN MAX DEF}, (@<ch_list>)
	ROUTE:CHANnel:DRive:PULSe:WIDTh? [{MIN MAX}, ] (@<ch_list>)
	ROUTE:CHANnel:DRive:STATe? (@<ch_list>)
	ROUTE:CHANnel:DRive:TIME:RECOvery {<seconds>  MIN MAX DEF}, (@<ch_list>)
	ROUTE:CHANnel:DRive:TIME:RECOvery? [{MIN MAX}, ] (@<ch_list>)
	ROUTE:CHANnel:DRive:TIME:SETTle {<seconds> MIN MAX DEF}, (@<ch_list>)
	ROUTE:CHANnel:DRive:TIME:SETTle? [{MIN MAX}, ] (@<ch_list>)
	ROUTE:CHANnel:LABel:CLEar:MODule <slot   ALL>
	ROUTE:CHANnel:LABel[:DEFine] "<label>", (@<ch_list>)
	ROUTE:CHANnel:LABel[:DEFine]? [<type>,] (@<ch_list>)
	ROUTE:CHANnel:VERify[:ENABle] {OFF 0 ON 1}, (@<ch_list>)
	ROUTE:CHANnel:VERify[:ENABle]? (@<ch_list>)
	ROUTE:CHANnel:VERify:POLarity {NORMal INVerted}, (@<ch_list>)
	ROUTE:CHANnel:VERify:POLarity? (@<ch_list>)
	ROUTE:CHANnel:VERify:POSition:STATe? (@<ch_list>)
	ROUTE:CLoSe (@<ch_list>)
	ROUTE:CLoSe? (@<ch_list>)
	ROUTE:MODule:BUSY? {1 ANY}
	ROUTE:MODule:WAIT <slot   ALL>
	ROUTE:MODule:WAIT? <slot   ALL>

**Table 5-1** 34945A SCPI Command Summary. (continued)

Subsystem	Commands
Switch Control cont'd	ROUTe:OPEN (@<ch_list>)
	ROUTe:OPEN? (@<ch_list>)
	ROUTe:OPERation:OVERlap[:ENABle] {OFF 0 ON 1}
	ROUTe:OPERation:OVERlap[:ENABle]?
	ROUTe:RMODule:BANK:DRIVE[:MODE] {TTL COLLector}, {1-4 BANK1-BANK4 ALL}, (@<rem_ch_list>)
	ROUTe:RMODule:BANK:DRIVE[:MODE]? {1-4 BANK1-BANK4}, (@<rem_ch_list>)
	ROUTe:RMODule:BANK:LED:DRIVE[:ENABle] {OFF 0 ON 1}, {1-4 BANK1-BANK4 ALL}, (@<rem_ch_list>)
	ROUTe:RMODule:BANK:LED:DRIVE[:ENABle]? {1-4 BANK1-BANK4}, (@<rem_ch_list>)
	ROUTe:RMODule:BANK:LED:DRIVE:LEVel {<amps> MIN MAX DEF}, {1-4 BANK1-BANK4 ALL}, (@<rem_ch_list>)
	ROUTe:RMODule:BANK:LED:DRIVE:LEVel? {1-4 BANK1-BANK4}, (@<rem_ch_list>)
	ROUTe:RMODule:BANK:PRESet {1-4 BANK1-BANK4 ALL}, (@<rem_ch_list>)
	ROUTe:RMODule:DRIVE:LIMit {<max_drives> MIN MAX DEF}, (@<rem_ch_list>)
	ROUTe:RMODule:DRIVE:LIMit? [{MIN MAX}, ] (@<rem_ch_list>)
	ROUTe:RMODule:DRIVE:SOURce:BOOT {OFF INTERNAL EXTERNAL}, (@<rem_ch_list>)
	ROUTe:RMODule:DRIVE:SOURce:BOOT? (@<rem_ch_list>)
	ROUTe:RMODule:DRIVE:SOURce[:IMMediate] {OFF INTERNAL EXTERNAL}, (@<rem_ch_list>)
	ROUTe:RMODule:DRIVE:SOURce[:IMMediate]? (@<rem_ch_list>)
	ROUTe:SEQUence:ABORT
	ROUTe:SEQUence:BUSY?
	ROUTe:SEQUence:CATalog?
ROUTe:SEQUence:DEFine <name>, "<commands>"	
ROUTe:SEQUence:DEFine? <name>	
(Sequence Operation)	ROUTe:SEQUence:DELeTe:ALL
	ROUTe:SEQUence:DELeTe[:NAME] <name>
	ROUTe:SEQUence:RUNNING:NAME?
	ROUTe:SEQUence:TRIGger[:IMMediate] <name>
	ROUTe:SEQUence:TRIGger:SOURce <name>, MANual
	ROUTe:SEQUence:TRIGger:SOURce? <name>
	ROUTe:SEQUence:WAIT

**Table 5-1** 34945A SCPI Command Summary. (continued)

Subsystem	Commands
<b>DIAGnostic</b>	DIAGnostic:RElAy:CYCLes? (@<ch_list>) DIAGnostic:RElAy:CYCLes:CLEar (@<ch_list>)
<b>Status</b>	*CLS *ESE <enable_value> *ESE? *ESR? *SRE <enable_value> *SRE? *STB? STATus:MODule:ENABle <enable_value> STATus:MODule:ENABle? STATus:MODule:EVENT? STATus:MODule:SLOT[n]:CONDition? STATus:MODule:SLOT[n]:ENABle <enable_value> STATus:MODule:SLOT[n]:ENABle? STATus:MODule:SLOT[n]:EVENT]? STATus:OPERation:CONDition? STATus:OPERation:ENABle <enable_value> STATus:OPERation:ENABle? STATus:OPERation[:EVENT]? STATus:PRESet STATus:QUEStionable:CONDition? STATus:QUEStionable:ENABle <enable_value> STATus:QUEStionable:ENABle? STATus:QUEStionable[:EVENT]? SYSTem:MODule?

**Table 5-1** 34945A SCPI Command Summary. (continued)

Subsystem	Commands
<b>State Storage</b>	*RCL {1 2 3 4 5}
	*SAV {1 2 3 4 5}
	MEMory:NSTates?
	MEMory:STAtE:CATalog?
	MEMory:STAtE:DELeTe {1 2 3 4 5}
	MEMory:STAtE:DELeTe:ALL
	MEMory:STAtE:NAME? {1 2 3 4 5} [, <name>]
	MEMory:STAtE:NAME? {1 2 3 4 5}
	MEMory:STAtE:RECall:AUTO {OFF 0 ON 1}
	MEMory:STAtE:RECall:AUTO?
	MEMory:STAtE:RECall:SElect {1 2 3 4 5}
	MEMory:STAtE:RECall:SElect?
MEMory:STAtE:VALid? {1 2 3 4 5}	
<b>IEEE-488 Commands</b>	*CLS
	*ESE <enable_value>
	*ESE?
	*ESR?
	*IDN?
	*OPC
	*OPC?
	*RCL {1 2 3 4 5}
	*RST
	*SAV {1 2 3 4 5}
	*SRE <enable_value>
	*SRE?
	*STB?
	*TRG
	*TST?
	*WAI

**Table 5-1** 34945A SCPI Command Summary. (continued)

Subsystem	Commands
<b>System - Related Commands</b>	SYSTem:CDEscription? <slot>
	SYSTem:COMMunicate:ENABle {OFF 0 ON 1},{GPIB LAN SOCKets TELNet VXI11 WEB}
	SYSTem:COMMunicate:ENABle? {GPIB LAN SOCKets TELNet VXI11 WEB}
	SYSTem:COMMunicate:GPIB:ADDRes <address>
	SYSTem:COMMunicate:GPIB:ADDRes?
	SYSTem:COMMunicate:GPIB:ADDRes:INSTalled?
	SYSTem:CPON <slot>
	SYSTem:CTYPe? <slot>
	SYSTem:CTYPe:RMOdule? (@<rem_ch>)[,<dist_board>]
	SYSTem:DATE <yyyy>,<mm>,<dd>
	SYSTem:DATE?
	SYSTem:DELay[:IMMediate] <seconds>
	SYSTem:ERRor?
	SYSTem:LOCK:OWNer?
	SYSTem:LOCK:RELease
	SYSTem:LOCK:REQuest?
	SYSTem:MODule?
	SYSTem:PRESet
	SYSTem:RMOdule:RESet <slot>
	SYSTem:RMOdule:STATus? <slot>
SYSTem:SECurity:IMMediate	
SYSTem:TIME <hh>,<mm>,<ss.sss>	
SYSTem:TIME?	
SYSTem:VERSion?	

**Table 5-1** 34945A SCPI Command Summary. (continued)

Subsystem	Commands
<b>LAN Configuration Commands</b>	SYSTem:COMMunicate:LAN:AUTOip {OFF 0 ON 1}
	SYSTem:COMMunicate:LAN:AUTOip?
	SYSTem:COMMunicate:LAN:BSTatus?
	SYSTem:COMMunicate:LAN:CONTRol?
	SYSTem:COMMunicate:LAN:DHCP {OFF 0 ON 1}
	SYSTem:COMMunicate:LAN:DHCP?
	SYSTem:COMMunicate:LAN:DNS "<address>"
	SYSTem:COMMunicate:LAN:DNS?
	SYSTem:COMMunicate:LAN:DOMain "<name>"
	SYSTem:COMMunicate:LAN:DOMain? [{CURRENT STATIC}]
	SYSTem:COMMunicate:LAN:GATEway <address>
	SYSTem:COMMunicate:LAN:GATEway? [{CURRENT STATIC}]
	SYSTem:COMMunicate:LAN:HISTory:CLEar
	SYSTem:COMMunicate:LAN:HISTory?
	SYSTem:COMMunicate:LAN:HOSTname "<name>"
	SYSTem:COMMunicate:LAN:HOSTname? [{CURRENT STATIC}]
	SYSTem:COMMunicate:LAN:IPADdress "<address>"
	SYSTem:COMMunicate:LAN:IPADdress? [{CURRENT STATIC}]
	SYSTem:COMMunicate:LAN:KEEPlive {<seconds> MIN MAX}
	SYSTem:COMMunicate:LAN:KEEPlive? [{MIN MAX}]
	SYSTem:COMMunicate:LAN:MAC?
	SYSTem:COMMunicate:LAN:SMASK "<mask>"
SYSTem:COMMunicate:LAN:SMASK? [{CURRENT STATIC}]	
SYSTem:COMMunicate:LAN:TELNet:PRoMpt "<string>"	
SYSTem:COMMunicate:LAN:TELNet:PRoMpt?	
SYSTem:COMMunicate:LAN:TELNet:WMESSage "<string>"	
SYSTem:COMMunicate:LAN:TELNet:WMESSage?	

## Y1150A - Y1155A Switch Control Tables

The following tables relate switch control actions 'open' and 'close' to the state of the switch and attenuator. The tables are identified by distribution board.

### Y1150A Switch Control

The switch control for the Y1150A distribution board is shown below. All channels are driven in the PAIRed mode (Preset state). See Figure 4-10 for additional information. See Chapter 2 for bank-specific channel numbering.

Channel / Switch	Switch State	
	State A	State B
Channel 1xx1 / SW1	ROUT:OPEN (@1xx1)	ROUT:CLOS (@1xx1)
Channel 1xx2 / SW2	ROUT:OPEN (@1xx2)	ROUT:CLOS (@1xx2)
Channel 1xx3 / SW3	ROUT:OPEN (@1xx3)	ROUT:CLOS (@1xx3)
Channel 1xx4 / SW4	ROUT:OPEN (@1xx4)	ROUT:CLOS (@1xx4)
Channel 1xx5 / SW5	ROUT:OPEN (@1xx5)	ROUT:CLOS (@1xx5)
Channel 1xx6 / SW6	ROUT:OPEN (@1xx6)	ROUT:CLOS (@1xx6)
Channel 1xx7 / SW7	ROUT:OPEN (@1xx7)	ROUT:CLOS (@1xx7)
Channel 1xx8 / SW8	ROUT:OPEN (@1xx8)	ROUT:CLOS (@1xx8)



## Y1151A Switch Control

The switch control for the Y1151A distribution board is shown below. All channels are driven in the single (un-paired) mode (Preset state). See Figure 4-11 for additional information. See Chapter 2 for specific channel numbering.

Channel / Switch 1	Path Closed	Path Open
Channel 1xx1 / SW1 Path 1	ROUT:CLOS (@1xx1)	Close another path or open all
Channel 1xx2 / SW1 Path 2	ROUT:CLOS (@1xx2)	Close another path or open all
Channel 1xx3 / SW1 Path 3	ROUT:CLOS (@1xx3)	Close another path or open all
Channel 1xx4 / SW1 Path 4	ROUT:CLOS (@1xx4)	Close another path or open all
Channel 1xx5 / SW1 Path 5	ROUT:CLOS (@1xx5)	Close another path or open all
Channel 1xx6 / SW1 Path 6	ROUT:CLOS (@1xx6)	Close another path or open all
Channel 1xx7 / SW1 Open All 1	ROUT:CLOS (@1xx7)	note: use either channel to open all
Channel 1xx8 / SW1 Open All 2	ROUT:CLOS (@1xx8)	

Channel / Switch 2	Path Closed	Path Open
Channel 1xx1 / SW2 Path 1	ROUT:CLOS (@1xx1)	Close another path or open all
Channel 1xx2 / SW2 Path 2	ROUT:CLOS (@1xx2)	Close another path or open all
Channel 1xx3 / SW2 Path 3	ROUT:CLOS (@1xx3)	Close another path or open all
Channel 1xx4 / SW2 Path 4	ROUT:CLOS (@1xx4)	Close another path or open all
Channel 1xx5 / SW2 Path 5	ROUT:CLOS (@1xx5)	Close another path or open all
Channel 1xx6 / SW2 Path 6	ROUT:CLOS (@1xx6)	Close another path or open all
Channel 1xx7 / SW2 Open All 1	ROUT:CLOS (@1xx7)	note: use either channel to open all
Channel 1xx8 / SW2 Open All 2	ROUT:CLOS (@1xx8)	

## Y1152A Switch Control

The switch control for the Y1152A distribution board is shown below. All channels are driven in the PAIRed mode (Preset state). See Figure 4-12 for additional information. See Chapter 2 for bank-specific channel numbering.

\* Note that for switches connected to SW1, path closed is accomplished with the **ROUTE:OPEN** command and path opened is accomplished through the **ROUTE:CLOSe** command.

Channel / Switch	Path State	
	Path Closed*	Path Opened*
Channel 1xx1 / SW1 Path1	ROUT:OPEN (@1xx1)	ROUT:CLOS (@1xx1)
Channel 1xx2 / SW1 Path2	ROUT:OPEN (@1xx2)	ROUT:CLOS (@1xx2)
Channel 1xx3 / SW1 Path3	ROUT:OPEN (@1xx3)	ROUT:CLOS (@1xx3)
Channel 1xx4 / SW1 Path4	ROUT:OPEN (@1xx4)	ROUT:CLOS (@1xx4)
Channel 1xx5 / SW1 Path5	ROUT:OPEN (@1xx5)	ROUT:CLOS (@1xx5)
Channel 1xx6 / SW1 Path6	ROUT:OPEN (@1xx6)	ROUT:CLOS (@1xx6)
Channel / Switch	Switch State	
	State A	State B
Channel 1xx7 / SW2	ROUT:OPEN (@1xx7)	ROUT:CLOS (@1xx7)
Channel 1xx8 / SW3	ROUT:OPEN (@1xx8)	ROUT:CLOS (@1xx8)

## Y1153A Switch Control

The switch control for the Y1153A distribution board is shown below. All channels are driven in the PAIRed mode (Preset state). See Figure 4-13 for additional information. See Chapter 2 for bank-specific channel numbering.

**ROUTE:OPEN** adds that section's attenuation amount to the overall attenuation. Total attenuation is the sum of the dB amounts for the individual sections switched in. When all channels open at reset maximum attenuation is set.

Channel / Attenuator Section	Attenuation State	
	Attenuation Section In	Attenuation Section Out
Channel 1xx1 / ATTN 1 SEC 1	ROUT:OPEN (@1xx1)	ROUT:CLOS (@1xx1)
Channel 1xx2 / ATTN 1 SEC 2	ROUT:OPEN (@1xx2)	ROUT:CLOS (@1xx2)
Channel 1xx3 / ATTN 1 SEC 3	ROUT:OPEN (@1xx3)	ROUT:CLOS (@1xx3)
Channel 1xx4 / ATTN 1 SEC 4	ROUT:OPEN (@1xx4)	ROUT:CLOS (@1xx4)
Channel 1xx5 / ATTN 2 SEC 1	ROUT:OPEN (@1xx5)	ROUT:CLOS (@1xx5)
Channel 1xx6 / ATTN 2 SEC 2	ROUT:OPEN (@1xx6)	ROUT:CLOS (@1xx6)
Channel 1xx7 / ATTN 2 SEC 3	ROUT:OPEN (@1xx7)	ROUT:CLOS (@1xx7)
Channel 1xx8 / ATTN 2 SEC 4	ROUT:OPEN (@1xx8)	ROUT:CLOS (@1xx8)

## Y1154A Switch Control

The switch control for the Y1154A distribution board is shown below. All channels are driven in the PAIRed mode (**Preset** state). See Figure 4-14 for additional information. See Chapter 2 for bank-specific channel numbering.

Channel / Switch	Switch State	
	State A	State B
Channel 1xx1 / SW1	ROUT:OPEN (@1xx1)	ROUT:CLOS (@1xx1)
Channel 1xx2 / SW2	ROUT:OPEN (@1xx2)	ROUT:CLOS (@1xx2)
Channel 1xx3 / SW3	ROUT:OPEN (@1xx3)	ROUT:CLOS (@1xx3)
Channel 1xx4 / SW4	ROUT:OPEN (@1xx4)	ROUT:CLOS (@1xx4)
Channel 1xx5 / SW5	ROUT:OPEN (@1xx5)	ROUT:CLOS (@1xx5)
Channel 1xx6 / SW6	ROUT:OPEN (@1xx6)	ROUT:CLOS (@1xx6)
Channel 1xx7 / SW7	ROUT:OPEN (@1xx7)	ROUT:CLOS (@1xx7)
Channel 1xx8 / SW8	ROUT:OPEN (@1xx8)	ROUT:CLOS (@1xx8)

## Y1155A Switch Control

The switch control for the Y1155A distribution board is shown below. Channels may be driven in single (un-paired) mode (Preset state), or in PAIRed mode. See Figure 4-15 for additional information. See Chapter 2 for bank-specific channel numbering.

### Single (un-paired) Mode

<b>Channel 1xx1 / Screw Term 1</b>	<b>ROUT: CLOS (@1xx1)</b>
<b>Channel 1xx2 / Screw Term 2</b>	<b>ROUT: CLOS (@1xx2)</b>
<b>Channel 1xx3 / Screw Term 3</b>	<b>ROUT: CLOS (@1xx3)</b>
<b>Channel 1xx4 / Screw Term 4</b>	<b>ROUT: CLOS (@1xx4)</b>
<b>Channel 1xx5 / Screw Term 5</b>	<b>ROUT: CLOS (@1xx5)</b>
<b>Channel 1xx6 / Screw Term 6</b>	<b>ROUT: CLOS (@1xx6)</b>
<b>Channel 1xx7 / Screw Term 7</b>	<b>ROUT: CLOS (@1xx7)</b>
<b>Channel 1xx8 / Screw Term 8</b>	<b>ROUT: CLOS (@1xx8)</b>
<b>Channel 1xx1 / Screw Term 11</b>	<b>ROUT: CLOS (@1xx1)</b>
<b>Channel 1xx2 / Screw Term 12</b>	<b>ROUT: CLOS (@1xx2)</b>
<b>Channel 1xx3 / Screw Term 13</b>	<b>ROUT: CLOS (@1xx3)</b>
<b>Channel 1xx4 / Screw Term 14</b>	<b>ROUT: CLOS (@1xx4)</b>
<b>Channel 1xx5 / Screw Term 15</b>	<b>ROUT: CLOS (@1xx5)</b>
<b>Channel 1xx6 / Screw Term 16</b>	<b>ROUT: CLOS (@1xx6)</b>
<b>Channel 1xx7 / Screw Term 17</b>	<b>ROUT: CLOS (@1xx7)</b>
<b>Channel 1xx8 / Screw Term 18</b>	<b>ROUT: CLOS (@1xx8)</b>

### Paired Mode

<b>Channel 1xx1 / Screw Term 1</b>	ROUT:OPEN (@1xx1)	ROUT:CLOS (@1xx1)
<b>Channel 1xx2 / Screw Term 2</b>	ROUT:OPEN (@1xx2)	ROUT:CLOS (@1xx2)
<b>Channel 1xx3 / Screw Term 3</b>	ROUT:OPEN (@1xx3)	ROUT:CLOS (@1xx3)
<b>Channel 1xx4 / Screw Term 4</b>	ROUT:OPEN (@1xx4)	ROUT:CLOS (@1xx4)
<b>Channel 1xx5 / Screw Term 5</b>	ROUT:OPEN (@1xx5)	ROUT:CLOS (@1xx5)
<b>Channel 1xx6 / Screw Term 6</b>	ROUT:OPEN (@1xx6)	ROUT:CLOS (@1xx6)
<b>Channel 1xx7 / Screw Term 7</b>	ROUT:OPEN (@1xx7)	ROUT:CLOS (@1xx7)
<b>Channel 1xx8 / Screw Term 8</b>	ROUT:OPEN (@1xx8)	ROUT:CLOS (@1xx8)

### Y1155A LED Connector Pins

Pin definitions for the Y1155A distribution board LED connectors are determined by the un-paired or paired mode of the Y1155A channels. The pin definitions for both modes are shown below.

### Un-paired Mode

LED1 Connector				LED2 Connector			
Pin	Use	Pin	Use	Pin	Use	Pin	Use
1	+VI	2	SW1	1	+VI	2	SW11
3	+VI	4	SW2	3	+VI	4	SW12
5	+VI	6	SW3	5	+VI	6	SW13
7	+VI	8	SW4	7	+VI	8	SW14
9	+VI	10	SW5	9	+VI	10	SW15
11	+VI	12	SW6	11	+VI	12	SW16
13	+VI	14	SW7	13	+VI	14	SW17
15	+VI	16	SW8	15	+VI	16	SW18

## Paired Mode

LED1 Connector				LED2 Connector			
Pin	Use	Pin	Use	Pin	Use	Pin	Use
1	+VI	2	SW1 - A	1	+VI	2	SW1 - B
3	+VI	4	SW2 - A	3	+VI	4	SW2 - B
5	+VI	6	SW3 - A	5	+VI	6	SW3 - B
7	+VI	8	SW4 - A	7	+VI	8	SW4 - B
9	+VI	10	SW5 - A	9	+VI	10	SW5 - B
11	+VI	12	SW6 - A	11	+VI	12	SW6 - B
13	+VI	14	SW7 - A	13	+VI	14	SW7 - B
15	+VI	16	SW8 - A	15	+VI	16	SW8 - B

## Drive Modes

The 34945EXT module can drive switches and attenuators using either TTL or open collector drive methods. The TTL drive mode uses active drive for both high and low levels and drives a TTL high level when asserted. The open collector drive provides a current path to ground when asserted.

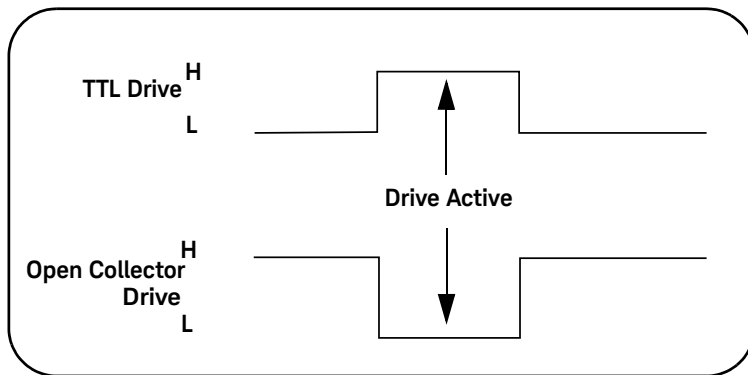

**Figure 5-1** TTL and Open Collector Drive Modes.

The drive mode is set on a per bank basis and is included in the distribution board's preset configuration. The drive mode can be changed using the command:

```
ROUTE:RMOdule:BaNK:DRIVE:MODE
```



## Using Single-Coil Switches and Attenuators

Some microwave switches require a single drive (coil). With single coil devices, note that the channel numbering is not consecutive across all channels in a bank (see Chapter 2 “Channel Numbering”).

The 34945A can provide single coil devices with either pulsed or continuous drive current. Settings and parameters for continuous drive mode are given in the next section.

### Continuous Drive Mode

Driving non-latching devices requires a power supply capable of handling sustained high current requirements. You may only use continuous drive current with channels configured for single drive. Additionally, to prevent an overcurrent condition within the power supply, care must be taken when operating more than one continuous drive at a time. The drive type may be configured as either TTL or open-collector.

### Using Continuous Drive

Figure 5-2 illustrates the continuous drive signals for two channels (switches) and the relationship of the drive parameters to the power supply requirements.

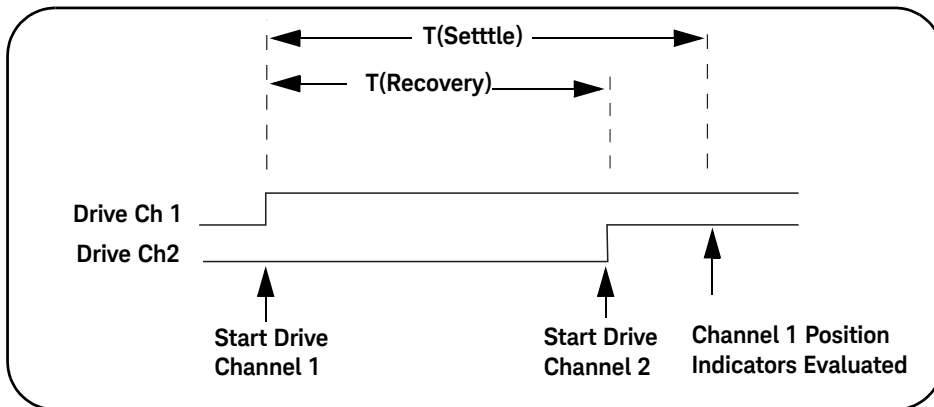

**Figure 5-2** Continuous Drive Signals.

As shown in the figure, the drive signal is initially applied to channel 1. Drive is applied to channel 2 only after a power supply recovery period has elapsed  $T(\text{Recovery})$ .

The power supply recovery time can be set for each channel, and is set to 0.0 ms during a bank **preset** (Chapter 4). The recovery time can be changed using the command:

**ROUTE:CHANnel:DRIVE:TIME:REcovery**

When verifying channel closure, you can also specify a settling time ( $T(\text{Settle})$ ). This parameter ensures the switch has had time to change state before the position indicator (of the switch) is evaluated.

The settling time can be set for each channel and is set to 0.0 ms during a bank **preset** (Chapter 4). The settling time can be changed using the command

**ROUTE:CHANnel:DRIVE:TIME:SETTle**

## Single Coil with Separate Position Indicators Connection Diagram

The simplified schematic on the following page illustrates the connection for a single coil switch (e.g. 8710x, 8740x) with separate position indicators. The position indicators for this type of switch are independent relay contacts that are mechanically linked to the RF switch position.

Even though this is a single coil (drive) switch, each switch state has its own coil. The switch uses internal logic to open all paths except the one being closed.

The RF paths are not shown in the simplified diagram. The coils are driven in open collector mode. The position indicator is set so that a high level indicates an active switch. The logic level of the position indicator can be inverted using the **ROUTE:CHANnel:VERify:POLarity** command.

The schematic shown is similar to the Keysight 87104A/B/C, 87106A/B/C, and 87406B switches. Many other switches use this technique (both with and without the position indicator) but may not have the logic described.

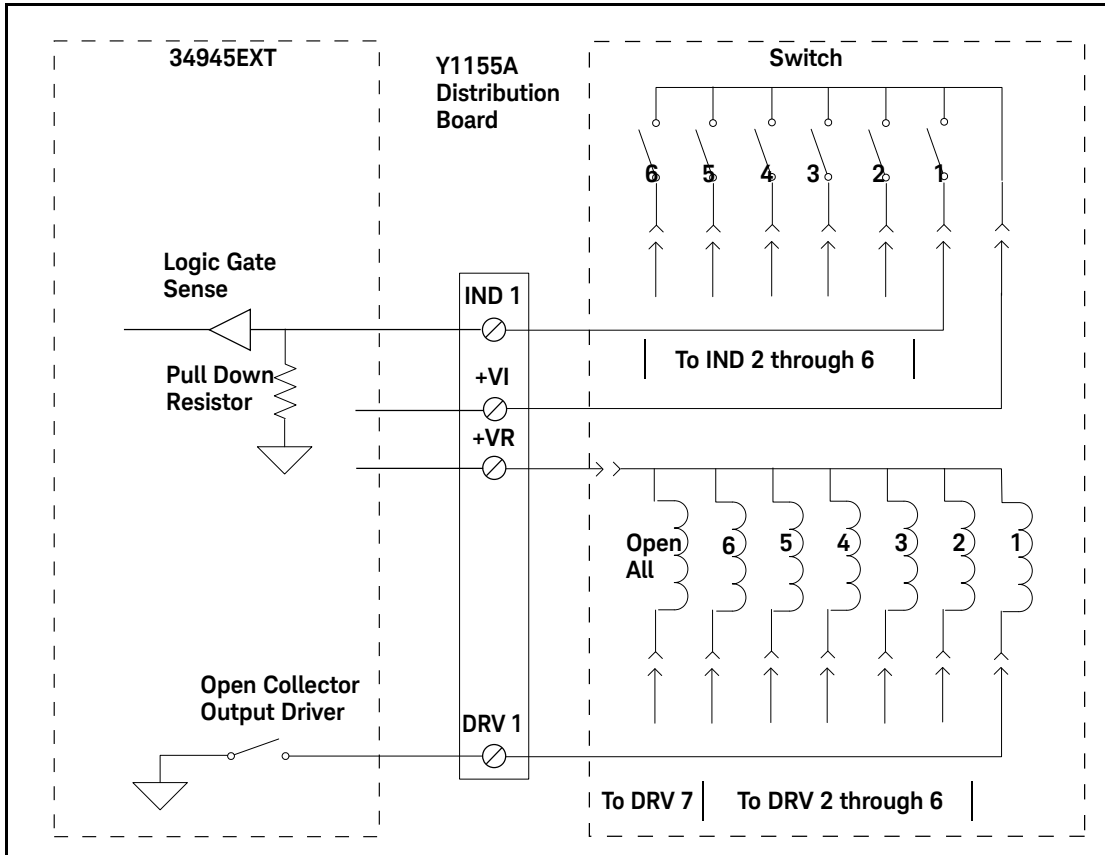

**Figure 5-3** Single-Coil Switch Connection Diagram (separate position indicators).

## Using Dual-Coil Switches and Attenuators

Many microwave switches and attenuators have a paired drive input. Typically, one drive is electrically connected to the lower channel number in a bank and one connected to a corresponding upper channel number. For example, on bank 2 a dual drive switch should have its 'State A' coil connected to channel 21 and its 'State B' coil connected to channel 31.

The 34945A drives dual coil devices in pulsed mode only (**ROUTE:CHANnel:DRIVE:PULSe:MODE ON**). Pairing two channels (**ROUTE:CHANnel:DRIVE:PAIR:MODE ON**) automatically configures the channels to pulsed mode. You must turn the paired mode 'off' before continuous drive mode can be enabled).

Based on the distribution board installed, presetting the bank will either enable paired mode (ON) or disable paired mode (OFF) according to the type of switches supported by the board.

### Pairing Channels

With dual-coil devices, the channels in the bank are paired during a bank preset. Pairing channels allows settings and control to be shared between the two channels. When paired, channels 1-8 are paired with 11-18 (bank 1), 21-28 with 31-38 (bank 2), 41-48 with 51-58 (bank 3), and 61-68 with 71-78 (bank 4). For example, a preset of bank 1 (Chapter 4) with an applicable distribution board or sending the command:

```
ROUTE:CHANnel:DRIVE:PAIRed:MODE ON, (@1101)
```

pairs channel 1 and channel 11. A bank preset pairs all channels in a bank as would the command sent to bank 1:

```
ROUTE:CHANnel:DRIVE:PAIRed:MODE ON, (@1101:1108)
```

As mentioned in Chapter 2, paired channels are controlled by a single command and only the lower channel of the pair is specified. Thus, the settings provided by the following commands:

**ROUTE:CHANnel:DRIVE:PULSe:WIDTh**

**ROUTE:CHANnel:DRIVE:TIme:RECOvery**

**ROUTE:CHANnel:DRIVE:TIme:SETTle**

**ROUTE:CHANnel:VERify:ENABle**

apply to both channels in the pair.

## Paired Drive With Separate Position Indicators

The simplified schematic below illustrates the connection for a dual coil switch with separate position indicators. The position indicators for this type of switch are independent relay contacts that are mechanically linked to the RF switch position.

The RF paths are not shown in the simplified diagram. The coils are driven in open collector mode. The position indicator is set so that a high level indicates an active switch. The logic level of the position indicator can be inverted using the **ROUTE:CHANnel:VERify:POLarity** command.

As shown, Channel 01 was pulsed to close Coil A. The corresponding position indicator also closed. Closing position indicator A opens position indicator B.

The schematic shown is similar to the Keysight N181x series of switches.

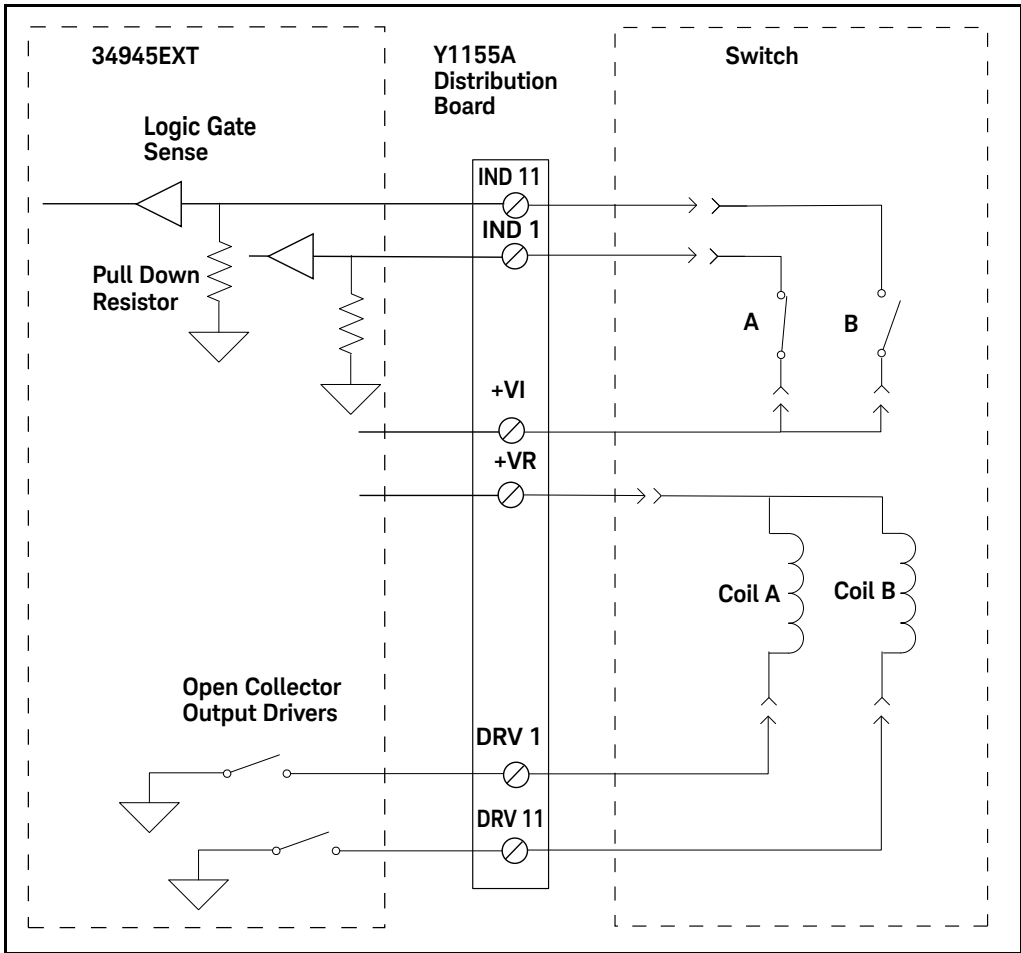

**Figure 5-4** Dual-Coil Switch Connection Diagram (separate position indicators).

## Paired Drive With Combined Position Indicators

The simplified schematic below illustrates the connection for a dual drive switch with an integral position indicator. The position indicators for this type of switch are electrically connected to the device's drive coil. This is a typical arrangement for microwave attenuators. For these types of position indicators, you must make a parallel connection at the distribution board between the channel drive and the indicator input.

With these types of devices, positive voltage is present on the paired coil opposite the position the switch is currently in. Typically you will need to invert the logic level of the position indicator using the **ROUTE:CHANnel:VERify:POLarity** command.

As shown, Channel 01 was pulsed to close Port 1. The corresponding position indicator also closed.

The schematic shown is similar to the Keysight 876x series of switches and 849x series of step attenuators.

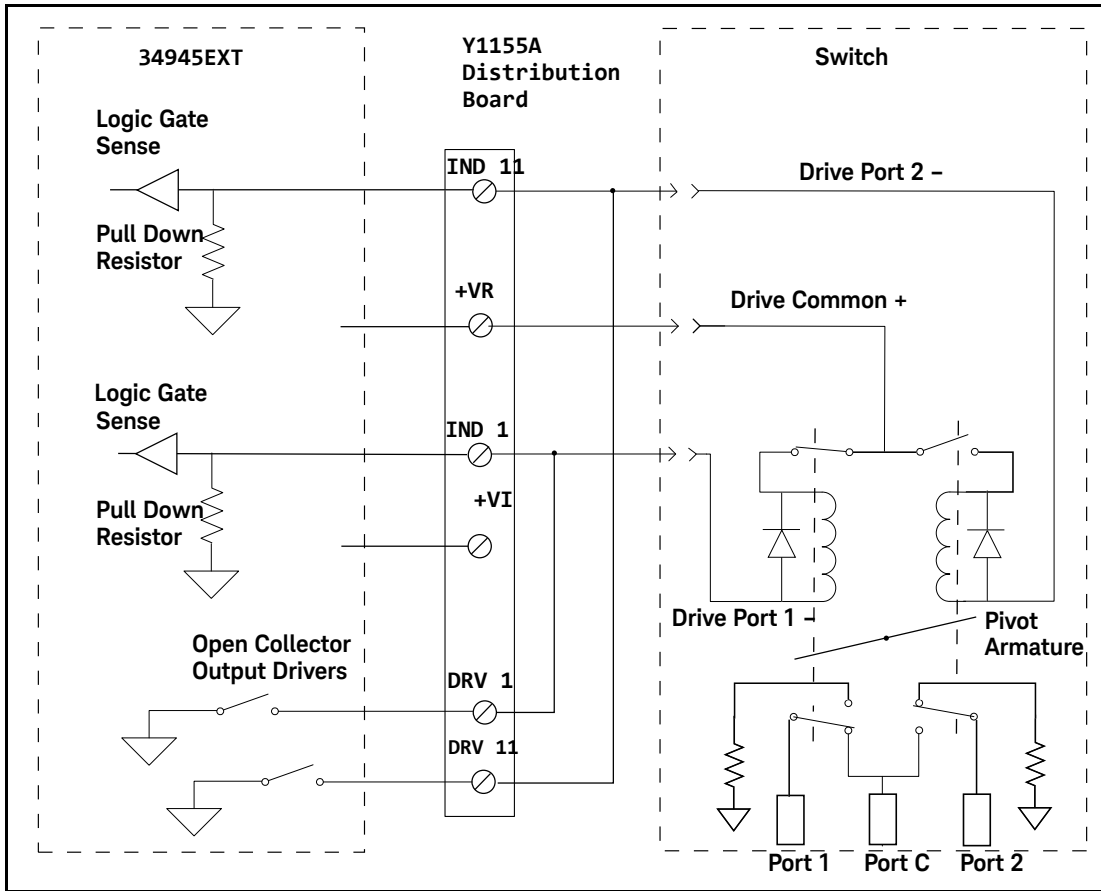

**Figure 5-5** Dual-Coil Switch Connection Diagram (combined position indicators).



## Pulsed Actuation Mode

The pulsed actuation mode is set during a bank **preset**. Pulsed mode can also be set with the command:

```
ROUTE:CHANnel1:DRIVE:PULSe:MODE ON
```

It is also set when channels are paired either through a bank preset or with the command:

```
ROUTE:CHANnel1:DRIVE:PAIRed:MODE ON
```

Figure 5-6 illustrates the pulse actuation for two channels (switches) and the relationship of the drive parameters to the power supply requirements.

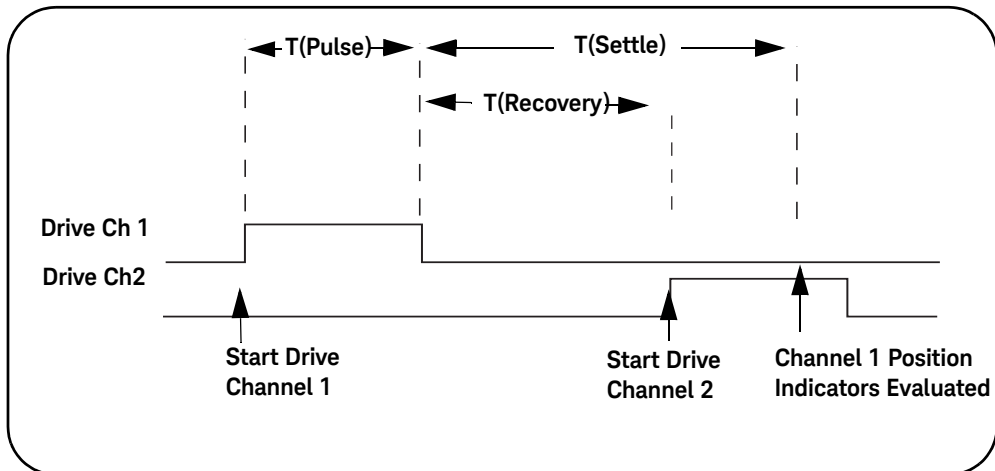

**Figure 5-6** Pulse Actuation Mode Diagram.

As shown in the figure, the actuation pulse is applied to channel 1 and held for the  $T(\text{Pulse})$  time set by the bank **preset** which is 15.0 ms, or as set with the command:

```
ROUTE:CHANnel1:DRIVE:PULSe:WIDTh
```

The actuation pulse is applied to channel 2 only after a power supply recovery period has elapsed  $T(\text{Recovery})$ . The power supply recovery time can be set for

each channel, and is set to 0.0 ms during a bank **preset** (Chapter 4). The recovery time can be changed using the command:

**ROUTe:CHANne1:DRIVE:TiMe:RECOvery**

When verifying channel closure, you can also specify a settling time (T(Settle)). This parameter ensures the switch has had time to change state before the position indicator (of the switch) is evaluated.

The settling time can be set for each channel and is set to 0.0 ms during a bank **preset** (Chapter 4). The settling time can be changed using the command

**ROUTe:CHANne1:DRIVE:TiMe:SETTle**

The 34945A will always pulse a channel in response to a **ROUTe:OPEN** or **ROUTe:CLOSe** command. For example, sending **ROUTe:CLOSe** to a channel three times in a row will result in three actuation pulses.

#### NOTE

A single coil (unpaired) channel operating in pulsed mode with channel verification turned off (default) will report the channel as 'stateless' and return an error if the command:

**ROUTe:CLOSe?**

is sent. Single coil channels driven by an actuation pulse must have verification enabled with the command:

**ROUTe:CHANne1:VERify ON)**

to query the channel state using the **ROUTe:CLOSe?** query.

## Overcurrent Conditions

During operation, exceeding the 34945A internal switch drive power supply quiescent current draw of 100 mA and switching pulse current of 200 mA can cause overcurrent conditions within the instrument's power supply, thus shutting down the supply and generating errors such as:

**+943,"Remote module topology change; Slot 1: Slot must be reset"**

**+308,"Channel not able to perform requested operation; Chan 1101: Remote module channel drive disabled"**

**+935,"Overcurrent detected"**

In this situation, the overcurrent condition must be removed and you must cycle power on the 34945A to re-enable the supply.

Overcurrent conditions are often caused by the actuation (switching) current the switch requires, and the duty cycle of the actuation pulse.

For the 34945A, the duty cycle is set through **presets** of the distribution boards, or can be set programmatically by combination of the commands:

**ROUT:CHANnel:DRIVE:PULSe:Width**

**ROUTE:CHANnel:DRIVE:TIME:RECOvery**

Figure 5-7 shows the relationship between actuation pulse width and power supply recovery time.

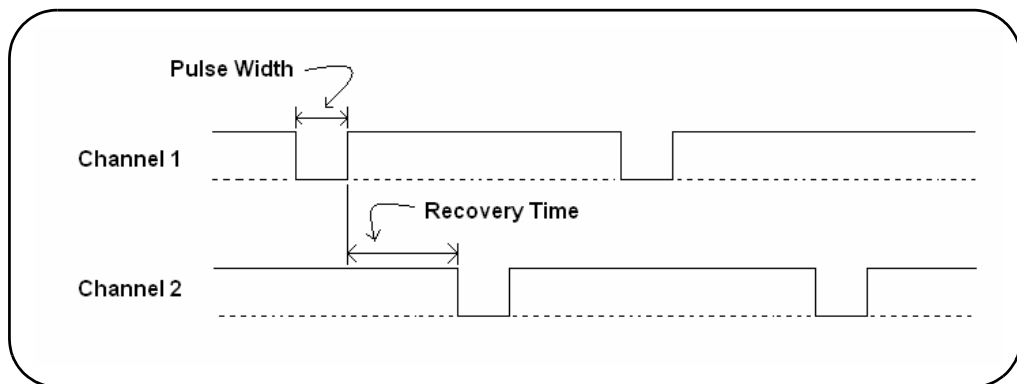

**Figure 5-7** Actuation Pulse Duty Cycle: Pulse Width + Recovery Time.

Overcurrent conditions can often be avoided with an activation pulse duty cycle of 25%. This allows the power supply to recover before the next actuation pulse is sent. An example of pulse width and recovery time values that achieve a 25% duty cycle is:

**ROUT:CHANnel:DRIVE:PULSE:Width 0.015, (@1101)**

**ROUTE:CHANnel:DRIVE:TIME:REcovery 0.045, (@1101)**

Because switching speeds vary between switches, it may be necessary to vary the pulse width and recovery time settings to achieve values that prevent overcurrent conditions, yet still achieve the desired system performance. Using switches with current interrupt options can also increase performance as less power is consumed by the switch.

## Overcurrent Conditions with External Supplies

Overcurrent conditions can occur using an external supply if the supported 2A limit of the 34945EXT is momentarily exceeded. The duty cycle of the externally supplied actuation pulse is regulated using the same commands as used with the internal supply.

## Command Execution Times

Setting pulse widths and/or power supply recovery times at, or close to their maximum values results in longer command (open/close) execution times. For example, setting a channel pulse width of 255 ms and a recovery time of 255 ms requires 510 ms for the command to complete. Setting these values for all channels on the 34945EXT could result in an execution time of over 30 seconds.

Note that during a reset, all channel states are actuated resulting in possible delays during the execution of:

**\*RST**

**SYSTEM:CPON**

**ROUTE:RModule:DRIVE:SOURce**

## Verifying Switch States

Many switches and attenuators have built-in switch position indicators. The indicators can be used to drive LED position indicators on the distribution boards. The 34945A checks the switch position indicator against the SCPI command last sent to provide verification of the state.

### Enabling Verification

Following a preset of any of the distribution boards, electronic verification is disabled and the switch state is assumed to be the last open/close state driven. Verification is enabled through the channel configuration window (Chapter 4) or using the command:

**ROUTE:CHANnel:VERify:ENABLE**

If a switch operation appears to have failed while electronic verification is enabled, an error is generated at the time either of the commands:

**ROUTE:CLOSe**

**ROUTE:OPEN**

is executed. If either of these commands specify a channel list (i.e., more than one channel), the verification is performed after all open/close operations have completed. An error is generated for each channel operation that did not verify correctly.

With electronic verification enabled, the commands:

**ROUTE:CLOSe?**

**ROUTE:OPEN?**

return the actual (verified) hardware state of the specified channel(s), which may or may not correspond to the programmed state.

Electronic verification of switch position will slow performance of the verified channels. Additionally, if you have enabled the command overlap function using the command:

**ROUTE:OPERation:OVERlap:ENABLE ON**

any overlapping is suspended until position verification is complete.

### Verification Line Polarity

The polarity of the verification lines is set following a **preset** of the distribution boards for the switches it supports. The polarity can also be set from the channel configuration window (Chapter 4) or with the command:

#### **ROUTE:CHANnel:VERify:POLarity**

The polarity settings are **NORMal** (active high - closed) or **INVerted** (active low - closed).

### Verifying the Switch State Independently

Electronic verification of the switch position is also possible without enabling verification from the channel configuration window (Chapter 4) or through the **ROUTE:CHANnel:VERify:ENABle** command. The command:

#### **ROUTE:CHANnel:VERify:POSition:STATe?**

verifies the channel state electronically and is useful when verification is disabled for performance reasons.

### Switch States Using Paired Channels

For paired channels, enabling electronic verification on the lower paired channel also enables verification of the higher channel. The verification checks for complementary switch positions of the lower and upper channels (i.e., the position indicators should indicate opposite states). If the position indicators are found to be in the same state an error is generated and the state of the lower channel is assumed.

When the paired mode is disabled and pulsed mode is enabled, you cannot query the channel state (opened/closed) unless verification is enabled. Also, with this configuration, only “close” operations are allowed.

## LED Drive Indicators

The distribution boards contain a ribbon cable header that can be used to connect LEDs to provide a visual indication of switch state (Chapter 2). These lines reflect the state of their corresponding channel's position indicator. Some systems use the LEDs as a graphical indicator of switch positions.

The LED drive indicators are enabled following a **preset** of the distribution boards (Chapter 4) and are also enabled with the command:

```
ROUTE:RMOdule:BANK:LED:DRIVE:ENABle
```

The drive current for the LEDs can be set from the bank configuration window (Chapter 4) or with the command:

```
ROUTE:RMOdule:BANK:LED:DRIVE:LEVe1
```

You do not need to provide an external current limiting resistor.

### NOTE

The LEDs obtain their power from the power supply of the 34945EXT module. If command:

```
ROUTE:RMOdule:DRIVE:SOURce OFF
```

has been sent, the LEDs will not operate. Refer to Chapter 2 for additional information on LED connector pin definitions and cabling.

---

THIS PAGE HAS BEEN INTENTIONALLY LEFT BLANK.



# Index

## Numerics

34945EXT  
bank numbering, 46  
connection to 34980A/  
34945A, 43  
description, 40  
maximum number, 40  
34945EXT interconnections, 43  
34945EXT module, 44  
34980A/34945A  
bank configuration  
window, 106  
browser web control  
page, 102  
drive modes, 152  
dual drive mode, 156  
factory settings, 135  
firmware pdates, 93  
pulse drive mode, 161  
remote module configuration  
window, 104  
SCPI command  
interface, 108  
SCPI command  
summary, 138  
single and continuous drive  
modes, 153  
switch/attenuator channel  
configuration window, 105  
using the web-enabled  
interface, 101  
web interface home  
page, 101  
web interface  
programming, 116  
849x series  
attenuator configuration and  
wiring, 61  
849x series attenuators  
changing settings, 124  
presetting, 123  
web programming, 123  
849xx series

attenuator configuration and  
wiring, 59, 62  
849xx series attenuators  
changing settings, 124  
presetting, 123  
web programming, 123  
87222 series  
switch configuration and  
wiring, 64  
87222 series switches  
changing settings and enabling  
the channel drive, 127  
presetting the bank, 126  
web interface  
programming, 126  
8765 series  
switch configuration and  
wiring, 68  
876x series  
switch configuration and  
wiring, 66  
876x series switches  
changing settings and enabling  
the channel drive, 129  
presetting the bank, 129  
web interface  
programming, 129  
876xK series  
switch configuration and  
wiring, 70  
876xM series  
switch configuration and  
wiring, 57  
876xM series switches  
changing settings, 124  
presetting, 123  
web programming, 123  
87xxx series  
switch configuration and  
wiring, 55  
87xxx series switches  
changing settings and enabling  
the channel drive, 119, 121  
presetting the bank, 119,

121  
web interface  
programming, 119, 121

## A

adding instruments to the  
interface, 80  
address string  
GPIB, 87, 89  
addressing  
IP addresses and host  
names, 84  
attenuator configuration and wir-  
ing  
849x series, 61  
849xx series, 59, 62  
attenuator configurations, 51

## B

bank commands, 47  
bank configuration window, 106  
bank diagram, 107  
bank preset  
87222 series, 126  
876x series, 129  
87xxx series, 119, 121  
L7222 series, 126  
L7xxx series, 119  
N1810 series, 116  
U9397A/C, 129  
browser web control page, 102  
bank configuration  
window, 106  
bank diagram, 107  
IsOpen/IsClosed, 107  
legend, 107  
observe only / allow full  
control, 104  
position indicator, 107  
remote module configuration  
window, 104  
SCPI command  
interface, 108

- switch/attenuator channel configuration window, 105
- viewing remote modules, 104
- web interface programming, 116

## C

- cable kits, 30
  - Y1157A, 30
  - Y1158A, 33
  - Y1159A, 36
- changing the GPIB address, 87, 89
- channel numbering, 46
- channel pairing, 48, 156
- channel/relay relationship, 47
- channels
  - non-paired, 48
- command execution times, 164
- command summary
  - SCPI, 138
- commands
  - bank, 47
  - module, 47
- computer configuration, 84
- configuration
  - LAN, 80
  - USB, 88
- Connection Expert
  - adding instruments to USB configuration, 88
  - Interactive IO, 91
  - locating instruments, 81
- Connection Expert utility
  - LAN configuration, 80
  - USB configuration, 88
- continuous drive mode, 153
- controller box
  - DC outputs, 42

## D

- DC output power supplies, 42
- defining sequences, 132
- development environments, 76
  - logging commands for transfer

- to, 109
- diagnostics, 111
- downloading updates, 93
- downloading the driver, 97
- driver updates, 93
- drivers, 76
- drivers,required, 123
- dual drive mode, 156
- dual-coil switches attenuators, 156

## E

- reference information
  - dual-coil devices, 156
- environments
  - operating and storage, 26
- equipment inventory, 25
- external power supplies, 43
- external power supply considerations, 50

## F

- factory settings, 134, 135
- firmware updates, 93
  - downloads, 93
  - installation, 93
  - update utility, 93

## G

- GPIB
  - adding instruments to the configuration, 87
  - address string, 87
  - changing the address, 87, 89
  - using Keysight Connection Expert, 86
- GPIB address
  - changing, 87
- GPIB interface
  - general information, 51

## H

- firmware
  - host name and IP address obtaining, 101
- IVI-COM
  - host names and IP addresses, 84

## I

- input power, 26
- installation
  - IVI drivers, 79
  - Keysight IO libraries, 77
- instrument addressing
  - GPIB address string, 87
  - IP addresses and host names, 84
  - USB address string, 89
- instrument configuration, 41
- instrument interconnections, 41
  - 34945EXT to 34945EXT, 43
  - 34945EXT to external power supplies, 43
  - 34980A/34945A to 34945EXT, 43
  - PC to 34980A/ 34945A, 43
- instruments
  - locating, 81
- Interactive IO, 91
- interface configuration
  - GPIB, 80
  - LAN, 80
  - USB, 80
- internal supply considerations, 49
- IO libraries
  - installation, 77
- IP address and host name obtaining, 101
- IP addresses and host names, 84
- isolated LAN networks, 40
- IsOpen/IsClosed, 107
- IVI drivers
  - installation, 79
- IVI-COM
  - driver updates, 93, 97

## K

Keysight Connection Expert  
Interactive IO, 91  
locating instruments, 81  
Keysight IO libraries  
installation, 77

## L

L4411A, programming environments, 123  
L4445A  
description, 40  
recovery time, 161  
settling time, 161  
L4490A  
factory settings, 134  
L4490A/L4491A  
controller box DC  
outputs, 42  
L4491A  
factory settings, 134  
L7222 series  
switch configuration and wiring, 64  
L7222 series switches  
changing settings and enabling the channel drive, 127  
presetting the bank, 126  
web interface programming, 126  
L7xxx series switches  
changing settings and enabling the channel drive, 119  
presetting the bank, 119  
web interface programming, 119  
LAN  
default configuration settings, 85  
network configuration, 40  
selecting a configuration, 40  
LAN configuration, 80  
LAN network  
considerations, 40  
selecting, 40  
LED drive indicators, 167

legend, 107  
locating information, 24  
locating instruments, 81  
logging commands, 109

## M

master module, 40  
materials included with shipment, 25  
module commands, 47

## N

N1810 series  
switch configuration and wiring, 51  
N1810 series switches  
changing settings and enabling the channel drive, 117  
presetting the bank, 116  
web interface programming, 116  
N1811 series  
switch configuration and wiring, 51  
N1812 series  
switch configuration and wiring, 51  
network configuration, 40  
private LAN considerations, 40  
site LAN considerations, 41  
network considerations, 40  
non-paired channels, 48  
numbering channels, 46

## O

open-collector drive mode, 152  
operating environment, 26  
output power supplies, 42  
overcurrent conditions, 163  
external supplies, 164

## P

pairing

channels, 48  
pairing channels, 156  
PC connection to instrument, 43  
position indicator, 107  
position indicator  
verification, 114  
power requirements, 26  
power supplies  
with external, 43  
external considerations, 50  
internal considerations, 49  
power supply considerations, 49  
power-on and reset states, 134  
private LAN networks, 40  
programming sequences, 132  
proxy server, 84  
pulse drive mode, 161  
pulsed actuation mode, 161

## R

recommended accessories  
distribution boards, 27  
switch options, 27  
table, 27  
recommended accessories cable kits, 27  
recommended drivers, 76  
recommended use model, 24  
recovery time  
L4445A, 161  
reference information, 165  
command execution times, 164  
drive modes, 152  
LED drive indicators, 167  
overcurrent conditions, 163  
pairing channels, 156  
pulsed actuation mode, 161  
single coil devices, 153  
relay/channel relationship, 47  
remote module configuration window, 104  
remote modules  
viewing, 104  
required drivers, 123  
reset and power-on states, 134  
RF platform

- position indicator
- verification, 114
- verification, 111
- verification sequence, 111

**S**

- SCPI command interface, 108
  - logging commands, 109
- SCPI command summary, 138
- sequence programming, 132
  - defining a sequence, 132
- settling time
  - L4445A, 161
- shipment
  - materials included, 25
- single drive mode, 153
- single-coil switches and attenuators, 153
- site LAN considerations, 41
- slave module, 40
- software installation
  - IVI drivers, 79
  - Keysight IO libraries, 77
  - software requirements, 76
- storage environment, 26
- switch configuration and wiring
  - 87222 series, 64
  - 8765 series, 68
  - 876x series, 66
  - 876xK series, 70
  - 876xM series, 57
  - 87xxx series, 55
  - L7222 series, 64
  - N1810 series, 51
  - U9397A/C, 72
- switch configurations, 51
- switch control tables, 144
  - Y1150A, 144
  - Y1151A, 145
  - Y1152A, 146
  - Y1153A, 147
  - Y1154A, 148
  - Y1155A, 149
- switch position indicators, 165
- switch state verification, 165
- switch states and position indicators, 165
- switch/attenuator channel configuration window, 105

**T**

- troubleshooting, 111

**U**

- U9397A/C
  - switch configuration and wiring, 72
- U9397A/C switches
  - changing settings and enabling the, 129
  - presetting the bank, 129
  - web interface programming, 129
  - updating firmware, 93
- USB
  - address string, 89
- USB configuration, 88
- USB interface
  - general information, 51
- use model, 24
- using the GPIB and USB interface
  - general information, 51

**V**

- verification
  - L4445A, 165
  - RF platform, 111
- verification sequence, 111
- viewing remote modules, 104

**W**

- web interface programming, 116
  - 8490x series attenuators, 123
  - 849x series attenuators, 123
  - 87222 series switches, 126
  - 876x series switches, 129
  - 876xM series switches, 123
  - 87xxx series switches, 119, 121
  - L7222 series switches, 126
  - L7xxx series switches, 119
  - N1810 series switches, 116
  - U9397A/C switches, 129
- Web-enabled instrument interface and Interactive IO, 91
- Web-enabled interface
  - browser web control page, 102
  - connecting to the instrument, 101
  - getting started, 101

**Y**

- Y1150A
  - configuration and wiring, 51
  - switch control table, 144
- Y1151A
  - switch control table, 145
- Y1152A
  - configuration and wiring, 55
  - switch control table, 146
- Y1153A
  - configuration and wiring, 57
  - switch control table, 147
- Y1153A configuration and wiring, 59, 61, 62
- Y1154A
  - configuration and wiring, 64
  - switch control table, 148
- Y1155A
  - LED connector pin definitions, 149
  - LED connector pins, 150
  - switch control table, 149
- Y1155A configuration and wiring, 66, 68, 70, 72
- Y1156A
  - position indicator verification, 114
  - verification board, 111
  - verification sequence, 111
- Y1157A cable, 51
- Y1157A cable kit assembly, 30
- Y1158A cable, 57, 59, 62, 64
- Y1158A cable kit assembly, 33
- Y1159A cable, 55
- Y1159A cable kit assembly, 36



This information is subject to change without notice. Always refer to the Keysight website for the latest revision.

© Keysight Technologies 2011-2022  
Edition 7, Aug 2022

Printed in Malaysia



34980-90045

[www.keysight.com](http://www.keysight.com)