

Keysight Technologies

Scienlab Dynamic DC Emulator

High Power Series – Up to 360 kW

SL1042A



Table of Contents

- System Description 3
- System Options 8
- Cabinet Base Option Class 8
- SL1042A-701 Base stand 8
- SL1042A-702 Rollers 8
- Interface Options Beyond Ethernet 8
- SL1042A-030 Additional EtherCat interface 8
- Test Bench Guard Ready – High Power DC Emulator Options 8
- SL1079A-DCE Test Bench Guard Ready – High Power DC Emulator 8
- Service Options 9
- HS0003A-100 Project Management 9
- R9001A-201 Installation Service 9
- R9001A-202 Start-up Assistance Service 9
- HS0002A- Productivity Support Service 10

System Description

The Dynamic DC Emulator (DCE) is an electric system designed to emulate batteries and other components for automotive applications. The following voltage, current and power options are available:

Voltage	50 – 600 V			
Current Options	600 A			
Power Options	250 kW	300 kW	330 kW	360 kW

Voltage	50 – 850 V				
Current Options	300 A	600 A			
Power Options	250 kW	250 kW	300 kW	330 kW	360 kW

Voltage	50 – 1000 V					
Current Options	300 A		600 A			
Power Options	250 kW	300 kW	250 kW	300 kW	330 kW	360 kW

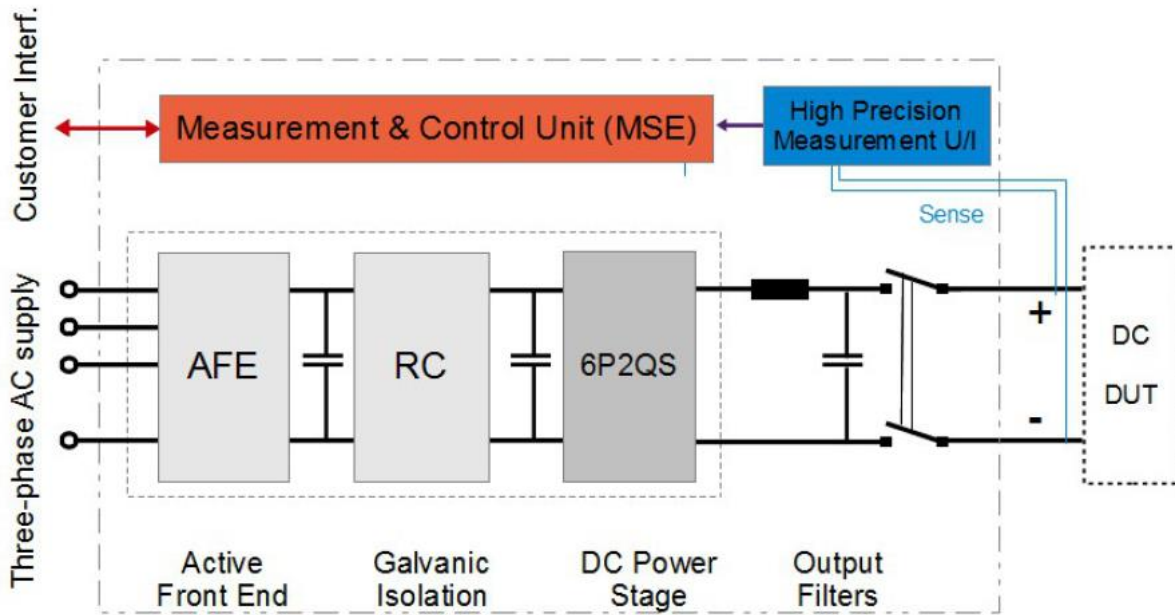

Figure 1: Dynamic DC Emulator system block diagram

Note: The Dynamic DC Emulator can be controlled with Emulator Control which is included in the position Machine Emulator.

Controller unit with power stage

MCU – (Measurement Controller Unit) real-time control module provides:

- Real-time computer controlling electrical output variables
- RLC simulation model
- Communication interface: Ethernet, incl. software interface description

Integrated battery model as per following equivalent circuit diagram:

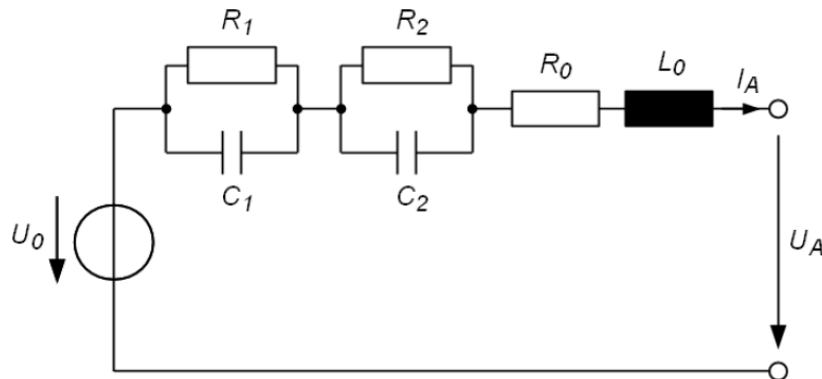

Figure 2: Battery model

The model shall only be active in voltage source operation.

Customer-settable parameters:

- U_0 : Nominal voltage source value [V]
- R_0 : Internal voltage source resistance [Ω]
- R_1 : Resistance within 1st RC link [Ω]
- C_1 : Capacity within 1st RC link [F]
- R_2 : Resistance within 2nd RC link [Ω]
- C_2 : Capacity within 2nd RC link [F]
- L_0 : Internal inductance [H]

Analog acquisition of voltage and current measuring (4-wire measurement)

	600 V	850 V	1000 V
Voltage accuracy	$\pm 0.05\%$ of measured value, ± 200 mV (offset)		$\pm 0.05\%$ of measured value, ± 300 mV (offset)

	300 A	600 A
Current accuracy	$\pm 0.05\%$ of measured value, ± 60 mA (offset)	$\pm 0.05\%$ of measured value, ± 120 mA (offset)

- Resolution: 32 Bit (IEEE 754-2008)
- Sample rate: max. 20 kS/s (internal 625 kS/s)
- DC measure and control accuracy are the same

Note: Connecting two systems in parallel has no effect on the voltage accuracy. The offset of the current accuracy is multiplied by two. The error of the measured value [%] is not affected.

Output characteristics

- Voltage ripple: 300 mV_{eff} typ., 500 mV_{eff} max. at measuring range of 500 kHz

	300 A	600 A
Output capacity	1600 μ F (800 μ F optional*)	3200 μ F (1600 μ F optional*)
Load stability	< 80 V (typ. < 40 V @ 400 V, 0 \rightarrow 250 A < 1ms, 400 μ F)	< 80 V (typ. < 40 V @ 400 V, 0 \rightarrow 500 A < 1ms, 400 μ F)

* For changing the output capacity please refer to operation instructions.

Explanation of load stability

- @ 400 V \rightarrow Output voltage of 400 V
- 0 \rightarrow 250 A, < 1 ms \rightarrow Current rise from 0 A to 250 A in less than 1 ms
- 500 μ F \rightarrow Load capacity (typical DUT input capacity)
- typically 40 V \rightarrow Average overvoltage of 40 V
- < 80 V \rightarrow Maximum 80 V overvoltage/undervoltage

Regenerative Power Stage

Voltage range of 2 quadrant system power stage:

Voltage options	600 V	850 V	1000 V
Source	50 – 600 V	50 – 850 V	50 – 1000 V
Sink	50 – 600 V	50 – 850 V	50 – 1000 V

- Modular rack-mounted system, easy to maintain

The default current and voltage ranges are shown in Figure 3 (2 quadrant system).

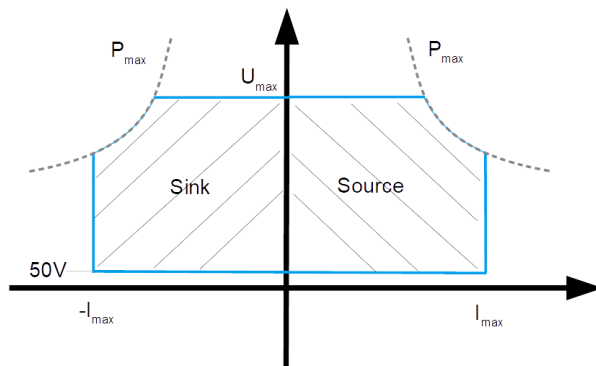

Figure 3: Max. power of 50 V to U_{max} (2 quadrant system).

Intrinsic safety

- Built-in safeguards against overheating, overcapacity, short circuit and idling
- Protection against reverse polarity by monitoring the polarity secured by software
- No hardware protection against reverse polarity before output contactors have been closed
- Monitoring of all internal voltages, currents and temperatures
- DC output contactors capable of disconnecting at full load current
- Mains side power contactors ensuring the absence of voltage
- Discharge of all internal high voltage sources upon emergency stop

System cabinet

- Basic dimensions H x W x D: 2.4 m x 3.6 m x 0.8 m placed on rollers plus overlap by switches etc.
- Weight: 2000 to 2300 kg
- Protection class IP 54
- Control cabinet color: RAL 7035
- Ambient temperature: 10 to 40 °C
- Air humidity: 30 to 75 % rel. H.
- Sound pressure level according to DIN EN 3744 < 70 dB(A) measured at 1 m distance from front

Documentation

- Operating instructions in English
- CE Declaration of Conformity
- Acceptance and calibration protocol

AFE (Active Front End)

- Regenerative
- Mains recovery (eff. > 90 %)
- Idle power compensation $\cos(\varphi) > 0.98$
- HF EMC filter
- 2 kHz filter
- Proof of limits having been respected for line-bound failures within low voltage mains as per EN61000-6-4:2007

Resonance converter

- All-pole isolation of power stages to supply mains

Mains supply

- 3, PE 400 V 50 Hz

System	250 kW	300 kW	330 kW	360 kW
Back-up fusing provided by customer	2x 224 A gG	2x 315 A gG	2x 315 A gG	2x 315 A gG

- Functional earth (FE)
- Roof-top cable routing with EMC screw connection

Power electronics cooling

- Water/water heat exchanger with internal water circuit to ensure dew protection
- Limitation of the water amount inside of the cabinet
- Monitoring of water temperature and internal controller
- Metal jacketed cooling water hoses

System cooling

System	250 kW	300 kW	330 kW	360 kW
Max. heat discharge	25 kW	30 kW	33 kW	36 kW
Throughput (full load) ($\vartheta_Z = 15\text{ °C}$, $\vartheta_R = 30\text{ °C}$, $\Delta\vartheta = 15\text{ K}$)	0.39 l/s (1.43 m ³ /h)	0.47 l/s (1.7 m ³ /h)	0.52 l/s (1.89 m ³ /h)	0.57 l/s (2.0 m ³ /h)

- Temperature of supply flow: 1 “, $\vartheta_Z = 6$ to 20°C
- Temperature of return flow: 1 “, $\vartheta_R = \text{max. } 30\text{ °C}$
- Max. input pressure 6 bar, without pressure, differential pressure: 1.5 to 3.0 bar
- Flow control meeting the specific demands
- Water stop valve

Safety

- Shut-down for emergency stop: U = 0 V or I = 0 A selectable
- Emergency stop-delay adjustable between 0 to 30 s
- Emergency stop/ main switch for all-pole disconnection
- Fast stop push button
- External fast stop input for Test Bench Guard integration
- Key switch for enabling the output contactors
- Door hinge mounted on the right side
- Door handles: Comfort handles with safety lock
- Parameterizable limits for the protection of the device under test
- Insulation guard monitor
- Evaluation of the insulation resistance via interface
- Insulation guard can be switched off

Note: If the insulation guard is switched off, a separate insulation guard must be available at the test item and is integrated in the emergency chain. The customer is then responsible for the safety of the test bench by himself.

- Signal light on the control cabinet with magnetic base
- Red: error; Yellow: Operation, Green: Ready for operation
- Indicators: Power coil instrument to indicate the terminal output voltage
- Measuring point: in front of the output contactor Display range: 0 – 1000 V, Fitting location: door

Interface to the supervisory system on the terminal block:

- Enabling of network side contactors
- Enable output contactors
- Signal output contact open / closed
- Message of limit value violation
- Message sums error
- Emergency stop message
- Release system
- Emergency stop input

System Options

Cabinet Base Option Class

SL1042A-701 Base stand

Control cabinet is placed on top of a 15 cm high base stand.
(total height including base stand: 2.38 m)

SL1042A-702 Rollers

Control cabinet stands on top of 25 cm high rollers and can be moved.
(total height including rollers: 2.48 m)

Interface Options Beyond Ethernet

The DCE supports the most common communication interfaces (Ethernet and EtherCat).

SL1042A-030 Additional EtherCat interface

Control cabinet is equipped with an extra EtherCat interface.

Test Bench Guard Ready – High Power DC Emulator Options

The Test Bench Guard manages the emergency stop signals and several external signals. The Cut-out scenarios are defined by a security matrix.

SL1079A-DCE Test Bench Guard Ready – High Power DC Emulator

The optional Test Bench Guard Ready enables a DC Emulator to connect to a Test Bench Guard.

Service Options

Service features depend on the facilities, expertise of the customer and overall scope of the project. For that reason, it is not possible to give exact service efforts without knowing the requirements and goals of the customer. Keysight offers the following services to secure a successful project execution and to reduce the ramp-up time for our customers.

HS0003A-100 Project Management

Project Management is recommended for each test bench project. By ordering the project management service, an experienced project manager is dedicated to your project and acts as direct communication interface from Keysight to the customers Project Management Team.

The project manager takes over the responsibility:

- To observe internal project progress and insure that project schedule/ project milestones are kept.
- That any unscheduled occasions with relevance for the project are immediately communicated and discussed with the customer.
- To provide complete and accurate project documentation to the customer.

R9001A-201 Installation Service

The scope of the offered Installation Service depends on the customer facility. Please share all relevant information and requirements regarding test bench components that require installation. Such requirements include connection to the local grid and local water supply. This allows your local field engineer to calculate the scope of service personnel and material costs for installation.

Note: Installation can also be executed by the customer.

R9001A-202 Start-up Assistance Service

The Start-up Assistance Service is offered to guide the customer during first usage of the test bench after installation. Start-up assistance service is recommended for each test bench project. It includes:

- Local presence of experienced test bench engineer during first usage of the test bench.
- Consulting of customer personnel with regards to intended usage of the test bench (e.g. initial test with customer specimen)
- Review of executed hardware installation of Keysight products
- Review and consulting to software settings of operation software if ordered
- Travel expenses

Note: Start-up Assistance Service is offered on a daily basis. Keysight recommends at least two days of start-up assistance service for each test bench project.

HS0002A- Productivity Support Service

The Productivity Support Service is offered to support, consult and train the customers operation personnel to reduce the ramp-up time for initial usage of a new test bench, on the other hand with regards to any unexpected system behavior during the test bench life cycle. Productivity Support Service is executed remotely (phone or internet) or on site (on request). It includes:

- Direct access to an experienced system specialist via phone/internet
- Support for failure analysis and trouble shoot
- Software and programming support & consulting

Note: Keysight recommends at least two days of productivity support service for each test bench project.

Learn more at: www.keysight.com

For more information on Keysight Technologies' products, applications or services, please contact your local Keysight office. The complete list is available at: www.keysight.com/find/contactus

