

# Keysight 1GG7-4156

## DC - 5 GHz SPDT Terminated Switch

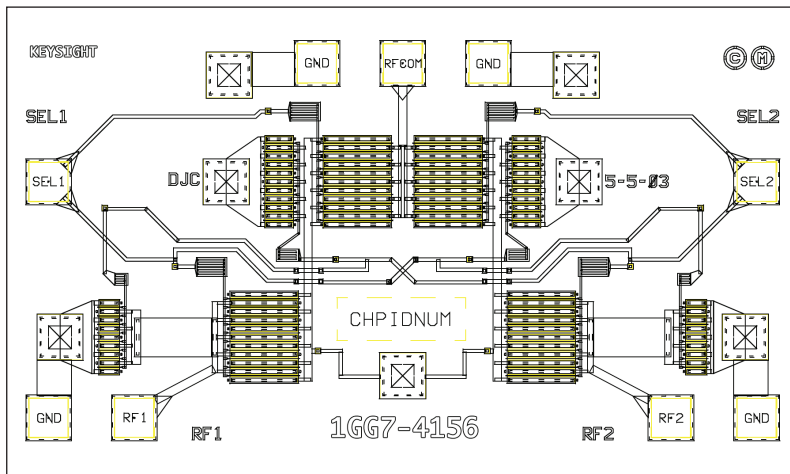

## Data Sheet

### Features

- Outputs terminated in 50  $\Omega$  when off
- Frequency range: DC to 3 GHz usable to 5 GHz
- Insertion loss: 0.8dB @ 3 GHz
- Isolation: > 45 dB @ 3 GHz
- Return loss: 20 dB
- Switching speed:
  - < 2 ns (10% to 90% RF)
- $P_{1dB}$  = > 30 dBm

## Description

The 1GG7-4156 is a GaAs monolithic microwave integrated circuit is fabricated using the Keysight Technologies, Inc. GaAs FET process and is designed for very low insertion loss and high isolation from DC to 3 GHz. It is intended for use as a high performance, singlepole, double-throw (SPDT), absorptive switch in applications requiring a very good match with the switch thrown ON or OFF. The 1GG7-4156 chip uses through-substrate vias to provide ground connections to the chip backside and minimize the number of wire bonds required.

## Absolute maximum ratings<sup>1</sup>

Symbol	Parameters/conditions	Min	Max	Units
$V_{sel}$	Select voltages 1 & 2	-10.5	+10.5	Volts
$P_{in}$	RF input power, instantaneous		+35	dBm
$P_{in}$	RF input power, continuous		+27	dBm
$T_{op}^2$	Operating temperature	-55	+125	°C
$T_{st}$	Storage temperature	-65	+165	°C
$T_{max}^3$	Maximum assembly temperature		+300	°C

1. Operation in excess of any one of these may result in permanent damage to this device.  
 $T_A = 25\text{ °C}$  except for  $T_{op}$ ,  $T_{st}$ , and  $T_{max}$ .
2. Operation in excess of these @  $T_{op-max}$  may result in permanent damage.
3. Maximum of 1 minute at the  $T_{max}$  temperature.

## Applications

The 1GG7-4156 can be used in instrumentation, communications, radar, ECM, EW, and many other systems requiring SPDT switching. It can be used for pulse modulation, port isolation, transfer switching, high-speed switching, replacement of mechanical switches, and so on.

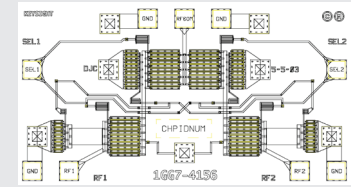

- Chip size:  
1,380 x 760  $\mu\text{m}$   
(54.3 x 29.9 mils)
- Chip size tolerance:  
 $\pm 10\ \mu\text{m}$  ( $\pm 0.4$  mils)
- Chip thickness:  
127  $\pm 15\ \mu\text{m}$   
(5.0  $\pm 0.6$  mils)

## RoHS Compliance

This device is RoHS Compliant. This means the component meets the requirements of the European Parliament and the Council of the European Union Restriction of Hazardous Substances Directive 2011/65/EU, commonly known as RoHS. The six regulated substances are lead, mercury, cadmium, chromium VI (hexavalent), polybrominated biphenyls (PBB) and polybrominated biphenyl ethers (PBDE). RoHS compliance implies that any residual concentration of these substances is below the RoHS Directive's maximum concentration values (MVC); being less than 1000 ppm by weight for all substances except for cadmium which is less than 100 ppm by weight.

## ESD and Handling Precautions

GaAs MMICs in either chip or SMT packages are ESD sensitive. ESD preventive measures must be employed in all aspects of storage, handling, and assembly.

MMIC ESD precautions, handling considerations, die attach and bonding methods are critical factors in successful GaAs MMIC performance and reliability.

Keysight *GaAs MMIC ESD, Die Attach and Bonding Guidelines - Application Note* (5991-3484EN) provides basic information on these subjects.

## Assembly Techniques

Die attach should be done with conductive epoxy. Gold thermosonic bonding is recommended for all bonds. The top and bottom metallization is gold. GaAs MMICs are ESD sensitive. ESD preventive measures must be employed in all aspects of storage, handling, and assembly. MMIC ESD precautions, handling considerations, die attach and bonding methods are critical factors in successful GaAs MMIC performance and reliability.

Keysight Technologies *GaAs MMIC ESD, Die Attach and Bonding Guidelines - Application Note*, literature number 5991-3484EN provides basic information on these subjects.

## Evolving

Our unique combination of hardware, software, support, and people can help you reach your next breakthrough. **We are unlocking the future of technology.**



From Hewlett-Packard to Agilent to Keysight



### myKeysight

#### myKeysight

[www.keysight.com/find/mykeysight](http://www.keysight.com/find/mykeysight)

A personalized view into the information most relevant to you.

### KEYSIGHT SERVICES

*Accelerate Technology Adoption.  
Lower costs.*

#### Keysight Services

[www.keysight.com/find/service](http://www.keysight.com/find/service)

Keysight Services can help from acquisition to renewal across your instrument's lifecycle. Our comprehensive service offerings—one-stop calibration, repair, asset management, technology refresh, consulting, training and more—helps you improve product quality and lower costs.

#### Keysight Channel Partners

[www.keysight.com/find/channelpartners](http://www.keysight.com/find/channelpartners)

Get the best of both worlds: Keysight's measurement expertise and product breadth, combined with channel partner convenience.

This data sheet contains a variety of typical and guaranteed performance data. The information supplied should not be interpreted as a complete list of circuit specifications. Customers considering the use of this, or other Keysight Technologies GaAs ICs, for their design should obtain the current production specifications from Keysight. In this data sheet the term typical refers to the 50th percentile performance. For additional information contact Keysight at [MMIC\\_Helpline@keysight.com](mailto:MMIC_Helpline@keysight.com).

The product described in this data sheet is RoHS Compliant. See RoHS Compliance section for more details.

[www.keysight.com/find/mmic](http://www.keysight.com/find/mmic)

For more information on Keysight Technologies' products, applications or services, please contact your local Keysight office. The complete list is available at: [www.keysight.com/find/contactus](http://www.keysight.com/find/contactus)

### Americas

Canada	(877) 894 4414
Brazil	55 11 3351 7010
Mexico	001 800 254 2440
United States	(800) 829 4444

### Asia Pacific

Australia	1 800 629 485
China	800 810 0189
Hong Kong	800 938 693
India	1 800 11 2626
Japan	0120 (421) 345
Korea	080 769 0800
Malaysia	1 800 888 848
Singapore	1 800 375 8100
Taiwan	0800 047 866
Other AP Countries	(65) 6375 8100

### Europe & Middle East

Austria	0800 001122
Belgium	0800 58580
Finland	0800 523252
France	0805 980333
Germany	0800 6270999
Ireland	1800 832700
Israel	1 809 343051
Italy	800 599100
Luxembourg	+32 800 58580
Netherlands	0800 0233200
Russia	8800 5009286
Spain	800 000154
Sweden	0200 882255
Switzerland	0800 805353
	Opt. 1 (DE)
	Opt. 2 (FR)
	Opt. 3 (IT)
United Kingdom	0800 0260637

For other unlisted countries:  
[www.keysight.com/find/contactus](http://www.keysight.com/find/contactus)  
(BP-06-08-16)

**DEKRA Certified**  
ISO 9001 Quality Management System

[www.keysight.com/go/quality](http://www.keysight.com/go/quality)  
Keysight Technologies, Inc.  
DEKRA Certified ISO 9001:2015  
Quality Management System