



Chapter 10

Active Mixer Design

PathWave Advanced Design System (ADS)

Taken from Keysight EEs of EDA Technical Note: Low Power Mixer Design Example Using Advanced Design System

Introduction

This chapter describes a method for designing a low-power single-transistor active mixer using Keysight Advanced Design System (ADS). It includes details on the design steps, simulation setups and data displays. The workspace file discussed in this lab is available in ADS. To find it, click the button labeled Open an Example Workspace in the ADS homepage. Under All Examples (in alphabetical order) click example titled **MixerPager_wrk.7zads**. Chose a workspace to place this file in and then let it unarchive itself. After the file has unarchived, in the list of available files in the folder, open and read the schematic in **01 ReadMe**.



Figure 1. How to open the ReadMe Schematic

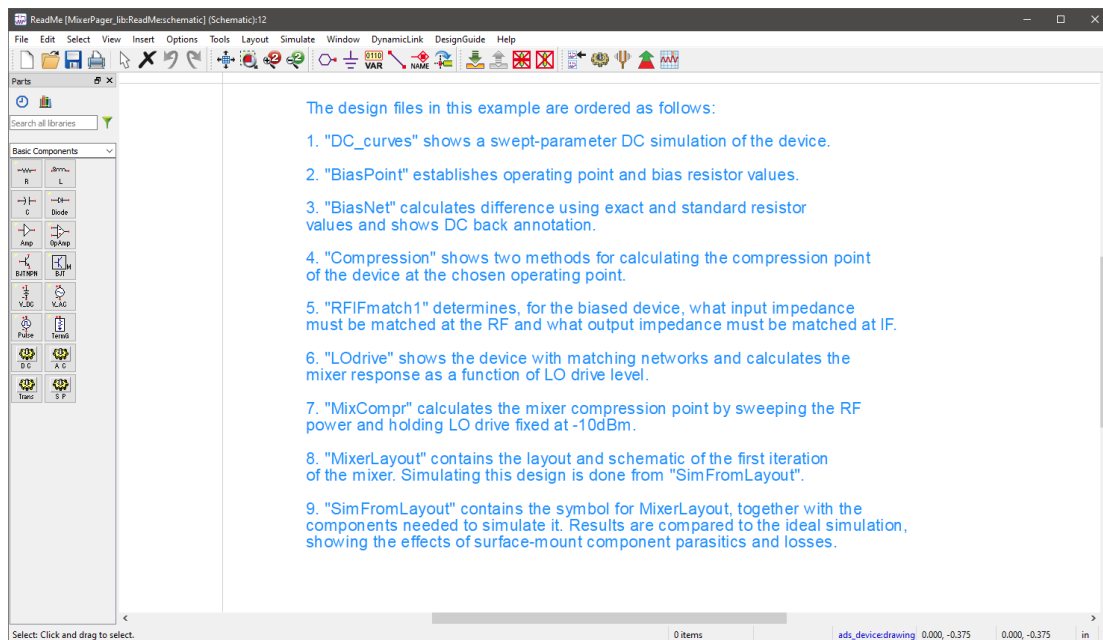

Figure 2. ReadMe File

Circuit Specifications

The mixer is an upper sideband down converter, with an RF of 900 MHz RF, and a 45 MHz IF. The simplified specifications supplied for this design call for it to provide a 10 dB conversion gain, operating from a 1 Volt DC supply at 600 μ A current. This very low power consumption is typical of applications such as pagers and cellular phones, where battery lifetime is critical. Low cost is another driving factor in such applications. Other typical specifications a mixer would have to meet in a “real-world” design, such as linearity, port-to-port isolation, spurious response and noise figure, are not included in this particular example. Open the examples in the workspace **Mixers_wrk.7zads** for examples of how to include these simulations in your design.

Device Selection

One of the first steps in the design process is to select the device. The device used for this example is the Motorola MMBR941, a bipolar junction transistor (BJT) packaged in a standard SOT-23 plastic package. While bipolar devices do not generally have as good of mixing properties as field-effect transistors, the low operating voltage precludes using FETs in this case. The chosen device has acceptable performance for this application and offers several other advantages: it is extremely low cost, and accurate models are readily available. A rule of thumb in high-volume, low-cost applications is to use the least expensive device that will accomplish the job, the MMBR941 is a good choice for this mixer. It is equally true that, no matter how good a device is, if there are no models with which to simulate it, it becomes impossible to use in a design.

The device model, taken from the ADS RF Transistor Library, is a Gummel-Poon model where the parameters were extracted by the manufacturer, Motorola. Initially, the model’s DC performance is verified by comparing DC I-V curves. Next, a bias network will be designed to establish the desired operating point. The model’s RF behavior will then be checked by comparing the simulated S-parameters with measured S-parameters taken at the same bias conditions. Finally, the model’s nonlinear performance is verified by simulating gain compression and comparing to measured results.

Device Model DC Verification (Cell: DC_curves)

DC_curves (see Figure 3) shows one way to set up a swept-parameter DC analysis. Open the **MixerPager_wrk** workspace. It is in **02_DC & Bias Point > DC_curves > schematic**. The DC voltage supply at the collector is set to a variable, **VCE**, which is initialized in the VAR block. The VAR block also initializes the variable, **IBB**, used in the DC current source at the base of the BJT. The actual values used for VCE are determined in the DC simulation controller (DC1). In this example, VCE is swept from 0 V to 6 V, so that the model can be verified over a relatively wide operating range. The DC controller can only sweep a single variable, so the values for IBB are swept using the ParamSweep component. The range chosen for the base current, IBB, is set to 50 to 350 μ A. This IV characteristics simulation setup is available as a default template in ADS and designers can obtain the same under Schematic page by selecting **Insert > Template > BJT Curve Tracer**. It can be used after setting IBB and VCE values as desired by designers.

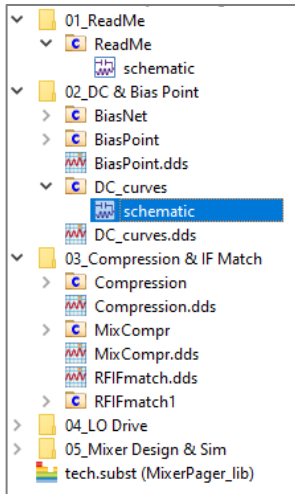

Figure 3. File location for DC_curves schematic

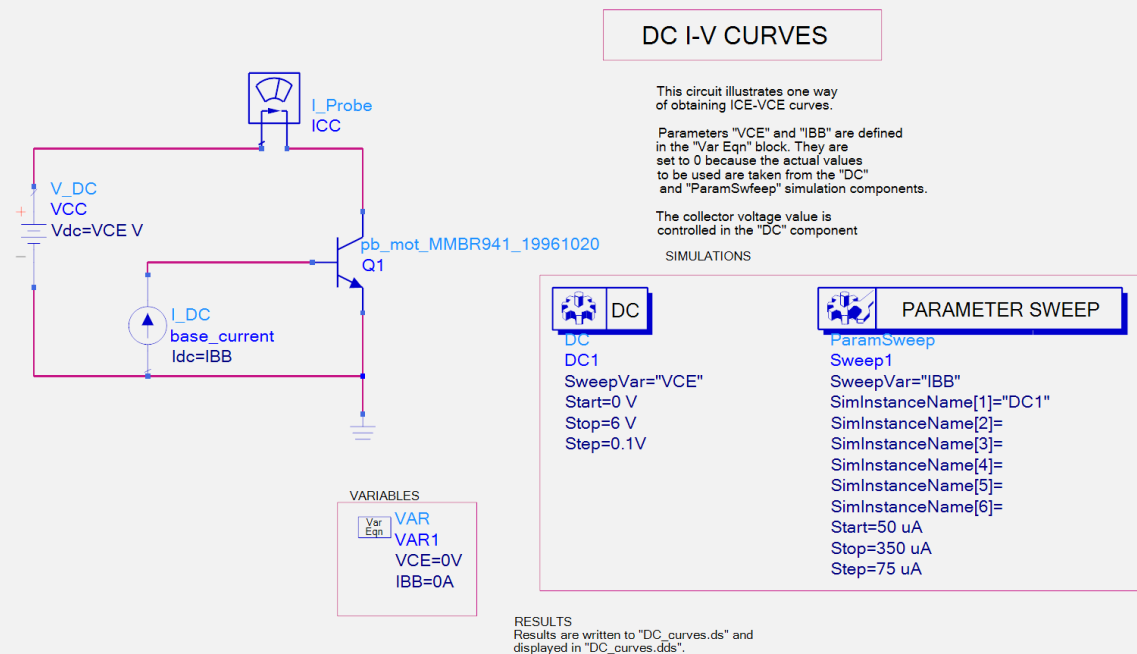

Figure 4. Transistor swept-parameter DC Analysis setup

Results from this simulation are displayed in **DC_curves.dds**. The available output variables can be viewed by either placing a new plot or selecting the existing plot for edit, which opens the Insert Plot dialog window shown in Figure 5. Notice that voltages at each of the named nodes are automatically supplied, as is the current at the DC supply (VCC.i).

The data from the current probe, ICC.i, is redundant in this case. The numbered nodes are used to store information for DC back annotation, discussed in the section on Device Model RF Verification.

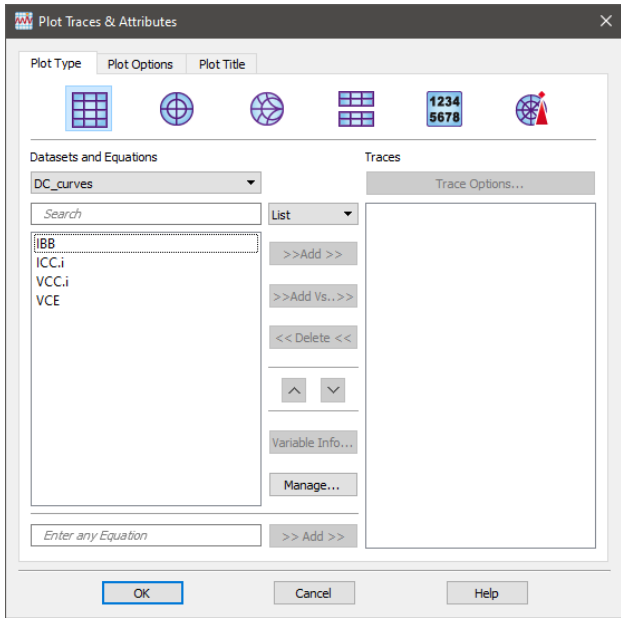

Figure 5. Insert Plot Diagram Box

Figure 6 shows there is good agreement between simulated and measured results. Measured data may be read into ADS from either data files or instruments by selecting **Window > New File/Instrument Server**. ADS will convert files in Touchstone, MDIF, Citifile or ICCAP formats to ADS datasets, which can then be displayed alongside simulated results. The I-V curves clearly show that, at the specified operating point of VCE = 1 V, ICE < 0.6 mA, the device will be operating in a low current regime. If designers do not have measure datafile, this step can be omitted.

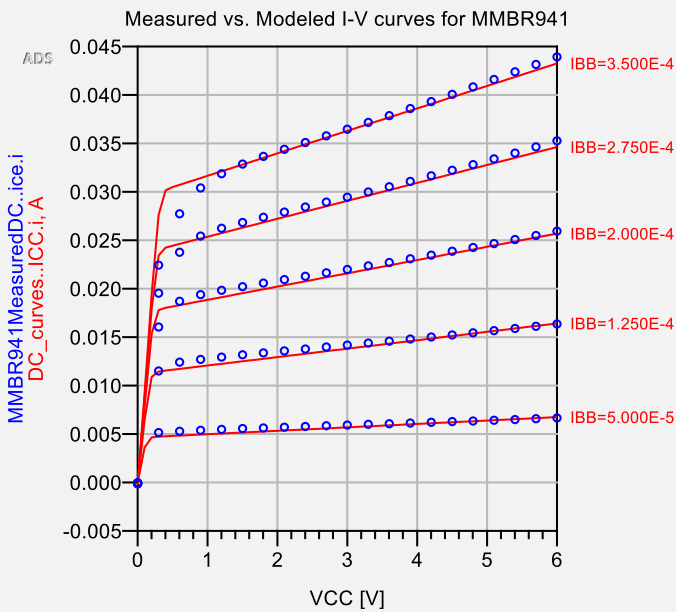

Figure 6. Comparison of Measured (symbols) and Simulated (solid line) DC I-V Curves for MMBR941

Bias Network Design (Cell: BiasPoint)

The next step, selecting the device operating point and calculating the required bias resistors, is done using the set-up in **Bias-Point (02_DC & Bias Point > BiasPoint > schematic)** as shown in Figure 7. Since the collector voltage and current have been specified, only the base current needs to be determined. In the schematic, VCC is fixed at 1V and IBB is swept from 1 to 10 μA , using the DC controller.

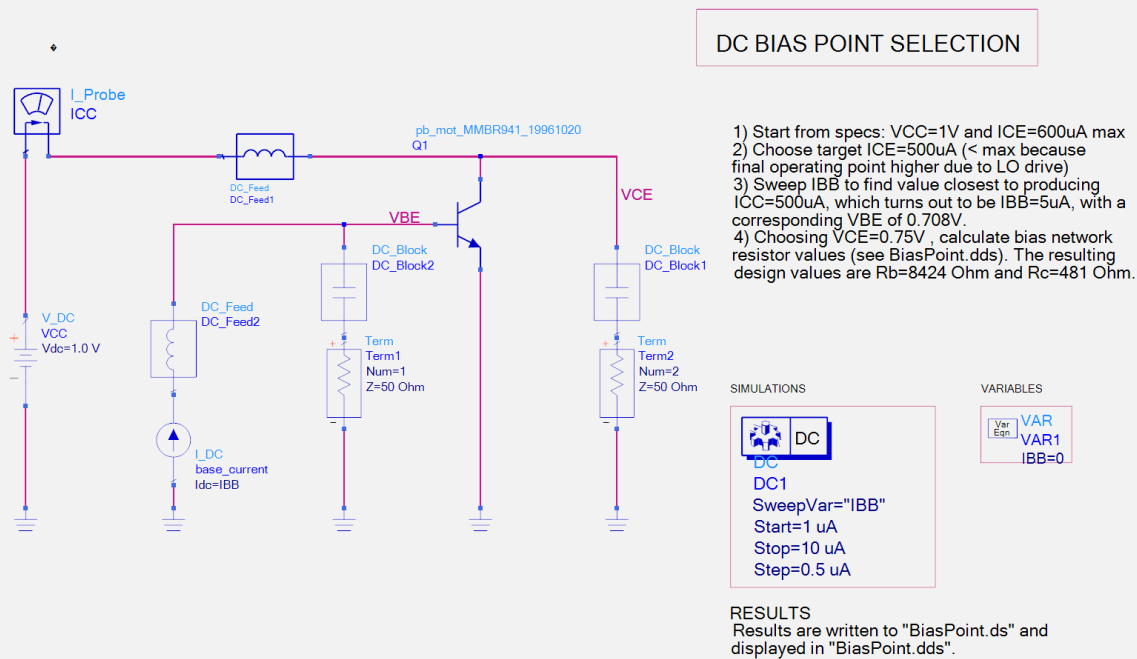

Figure 7. Calculation of Bias Point

The schematic contains bias tee components (the **DC_Feed** and **DC_Block** components) and $50\ \Omega$ terminations that mimic the actual test setup used to measure the device. However, since the DC simulation does not include any RF signals, they are not necessary at this point, and can be omitted without changing the results. The results are displayed in tabular format in **BiasPoint.dds** (see Figure 8), so the appropriate base current can be selected. Note that the bias point current is actually lower than the specified final value. This is because the device will be pumped with a relatively large LO signal, causing a shift in the DC component of the collector current.

This shift will be calculated more precisely later on but, for now, I_{BB} is selected to be $5\ \mu\text{A}$ so that the corresponding collector current ($514\ \mu\text{A}$) is well below the specification.

Table 1: ICE and VBE vs. IBB, VCC=1V

IBB	BiasPoint..ICC.i	BiasPoint..VBE
1.000E-6	102.7 uA	665.5 mV
1.500E-6	154.5 uA	676.2 mV
2.000E-6	206.3 uA	683.8 mV
2.500E-6	257.9 uA	689.6 mV
3.000E-6	309.4 uA	694.4 mV
3.500E-6	360.8 uA	698.5 mV
4.000E-6	412.2 uA	702.0 mV
4.500E-6	463.4 uA	705.1 mV
5.000E-6	514.6 uA	707.9 mV
5.500E-6	565.7 uA	710.4 mV
6.000E-6	616.8 uA	712.7 mV

Sweeping IBB shows we need IBB=5uA to have ICC~500uA. The corresponding VBE is 0.708V.

Figure 8. Device Operating Point Selection

The bias resistor values, shown in Figure 9, are calculated next. Base current, collector current, and VCC are known, but the designer must make an assumption about the voltage drop across R to be able to solve for Rc and Rb. In this case, a collector-emitter voltage of 0.75 V is chosen, providing a reasonable working voltage at the output and realizable resistor values. The equations, written in the data display page, calculate the exact values required for each value of base current, but of course the nearest standard values must be chosen. The next step is to confirm bias operation using these standard values and then verify the S-parameters of the model against measured values.

Table 2: Calculated Rb and Rc

IBB	Rb	Rc
1.000E-6	84529.635	2410.638
1.500E-6	49209.429	1602.222
2.000E-6	33115.916	1200.472
2.500E-6	24143.233	960.191
3.000E-6	18520.552	800.304
3.500E-6	14716.285	686.232
4.000E-6	11998.583	600.741
4.500E-6	9976.677	534.280
5.000E-6	8424.296	481.125
5.500E-6	7202.032	437.642
6.000E-6	6219.680	401.408
6.500E-6	5416.501	370.749

$$Eqn Rb = (0.75 - VBE) / IBB$$

$$Eqn Rc = (0.25) / (ICC.i + IBB)$$

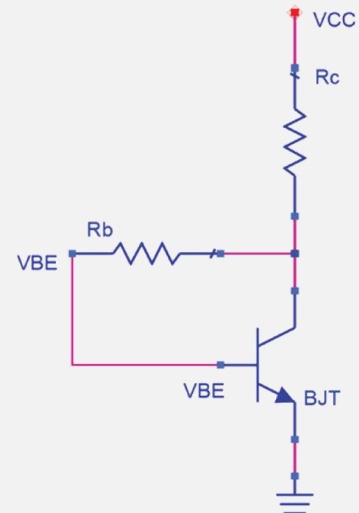

Figure 9. Calculation of Bias Network Resistors

Device Model RF Verification (Cell: BiasNet)

BiasNet (02_DC & Bias Point > BiasNet > schematic), shown in Figure 10, includes both DC and S-parameter simulations so, in this case, bias tee components (DC feeds and blocks) are required to ensure proper RF performance. DC results are displayed directly on the schematic page, using the DC back annotation feature. Once the simulation has been run, select **Simulate > Annotate DC Solution** to see the DC voltages and currents at each node. This simulation can be done with both the exact resistor values and nearest standard values ($R_c = 470 \Omega$, $R_b = 8.2 \text{ k}\Omega$) to confirm that the operating point is correct.

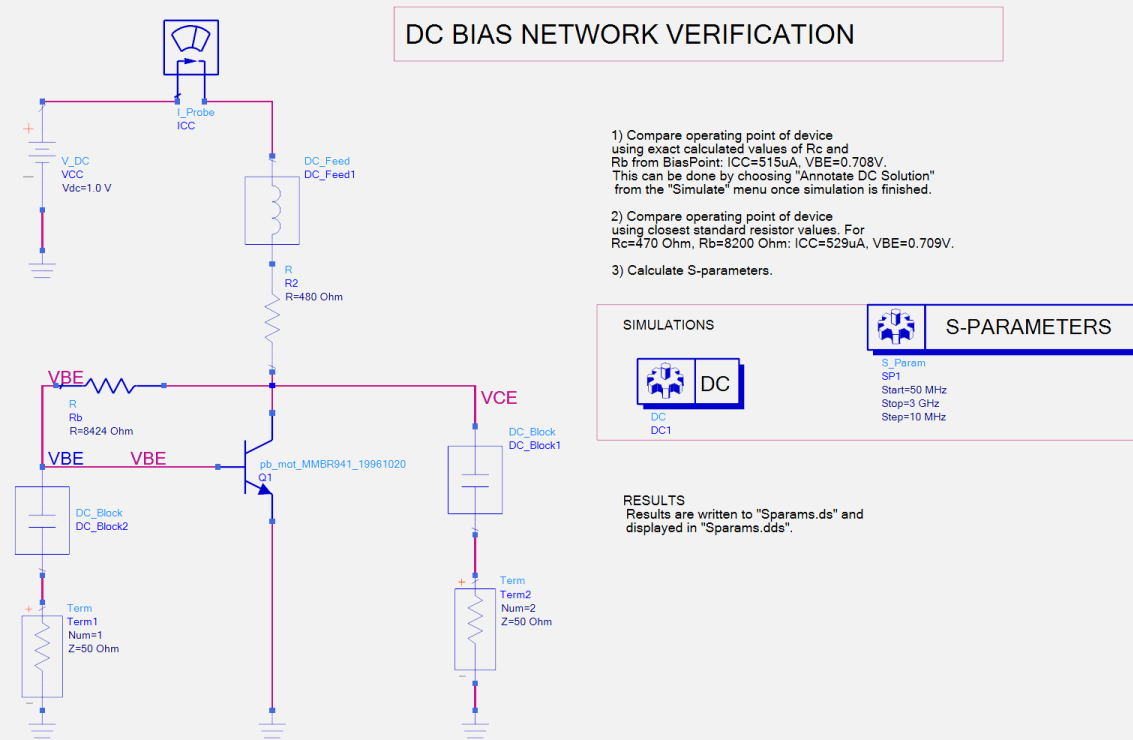

Figure 10. DC and S-Parameter Simulation Setup

The device S-parameters are calculated at this operating point and displayed, together with measured data in Figure 11. The good agreement obtained here verifies the small-signal RF performance. The device compression point will be simulated next to confirm large-signal operation.

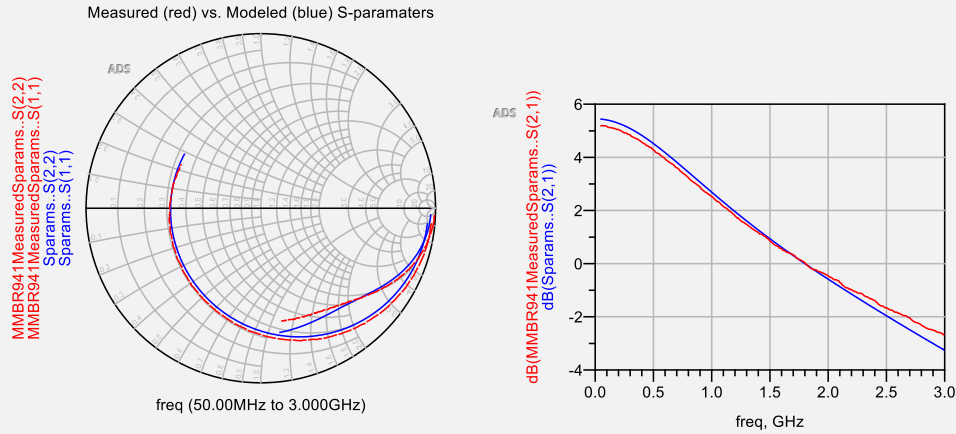

Figure 11. Comparison of Measured and Simulated S-Parameters for MMBR941.

Device Model Large-Signal Verification (Cell: Compression)

Compression (03_Compression & IF Match > Compression > schematic), shown in Figure 12, shows two ways of calculating the device output compression at the RF frequency of 900 MHz. The conventional way, implemented here with the Harmonic Balance controller, is to sweep the input power level from low (i.e. small-signal) to high values until the output power compresses (the ratio P_{out}/P_{in} starts to fall off from its small-signal value). The input power variable, "PwrIn" is swept from -45 to -5 dBm and a Measurement Equation component is used to define the output power at 900 MHz, in dBm. Notice that the dBm function assumes the power is being delivered to a 50 Ω load, unless otherwise specified by the user. The argument of the function, "HB.Vout[1]", specifies the fundamental frequency. Figure 13 shows the equation and graph used to determine the 1 dB compression point and includes the measured results as well.

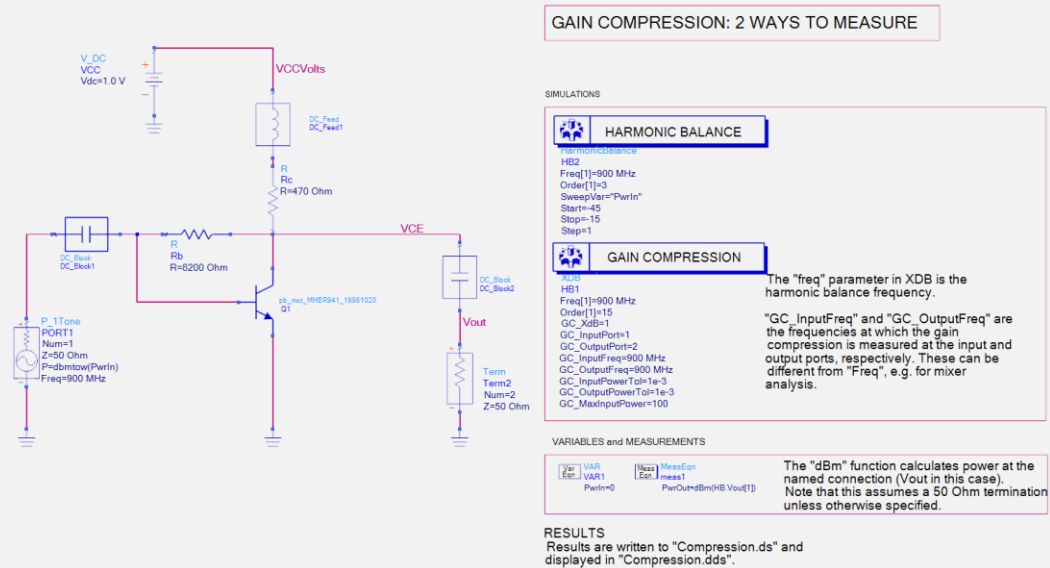

Figure 12. Device Comparison Measurement Setup

The second method, unique to ADS, is more direct and does not require graphs or sweeping variables. The Gain Compression controller “XDB” performs a harmonic balance analysis that correctly calculates and outputs the input and output power levels at the specified compression point. The default setting is 1 dB, but the user can specify any amount of compression. Figure 13 also shows the output from this method: the input and output power levels at 1 dB compression are listed in dBm.

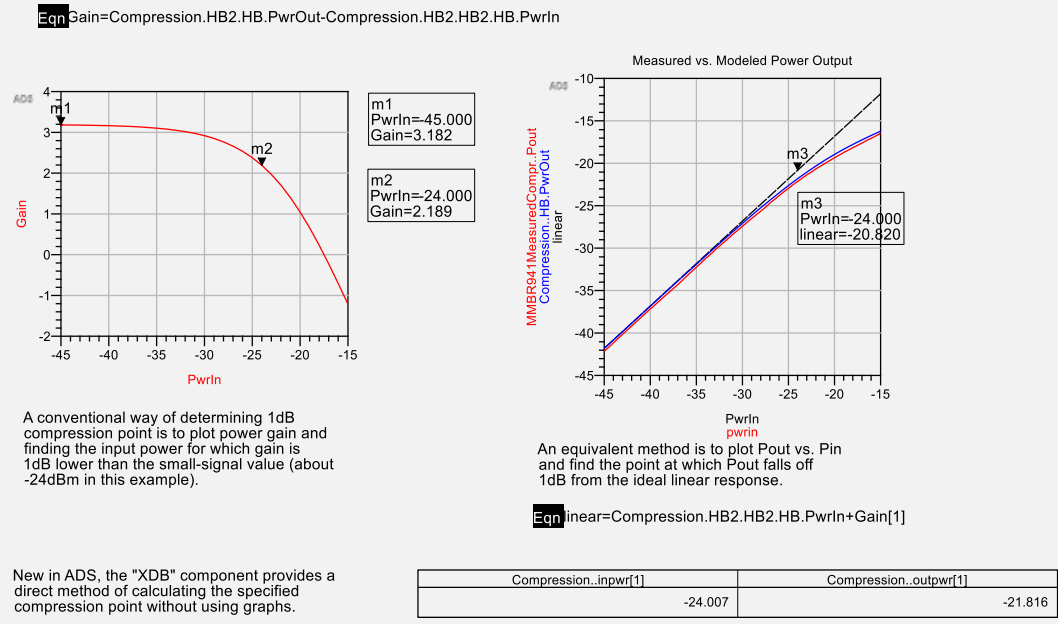

Figure 13. Two Methods of Determining 1 dB Compression – both show input P1 dB is -24 dBm.

ADS offers a great deal of flexibility in where and how output data are defined. To take a simple example, “PwrOut” has been defined on the schematic page using a MeasEqn component, but it could equally well have been defined on the data display page as an equation. An advantage of defining outputs on the schematic is that they can be used in optimizations. On the other hand, defining them on the data display page is useful for setting up templates (where complex calculations can be easily applied to many different schematics). Also, any outputs that were overlooked before the simulation was run can be calculated afterwards by adding them on the data display page.

Notice that, at this point, the design still uses ideal bias tee components to isolate the DC and RF signal paths. These will be replaced with the real components that make up the matching networks in the next stage of the design.

Mixer Matching Circuit Design

An important step in mixer design is determining what impedances are seen at each port for both the RF and IF. The finished input network will match the device base to $50\ \Omega$ at the RF and present a short circuit at the IF (to prevent any noise at the input being amplified and interfering with the IF at the output). Similarly, the output network will match the collector to $50\ \Omega$ at the IF, while presenting a short circuit to the RF. Thus, for each frequency, the terminations seen at the input and output of the device are completely different. Since the device is not unilateral, the presence of a short circuit on one side of the device will affect the impedance seen at the other side for matching purposes.

The first step in designing the input matching network, then, is to determine the device input impedance at the RF when the output is terminated in a short circuit. For the output matching network, the designer needs to know the BJT's output impedance at the IF when the input is terminated in a short circuit. In ADS, equation-based 1-port Z-parameter components are used to simulate this sort of idealized frequency-dependent termination, as seen in **RFIFmatch1 (03_Compression & IF Match > RFIFmatch1 > schematic)** in Figure 14.

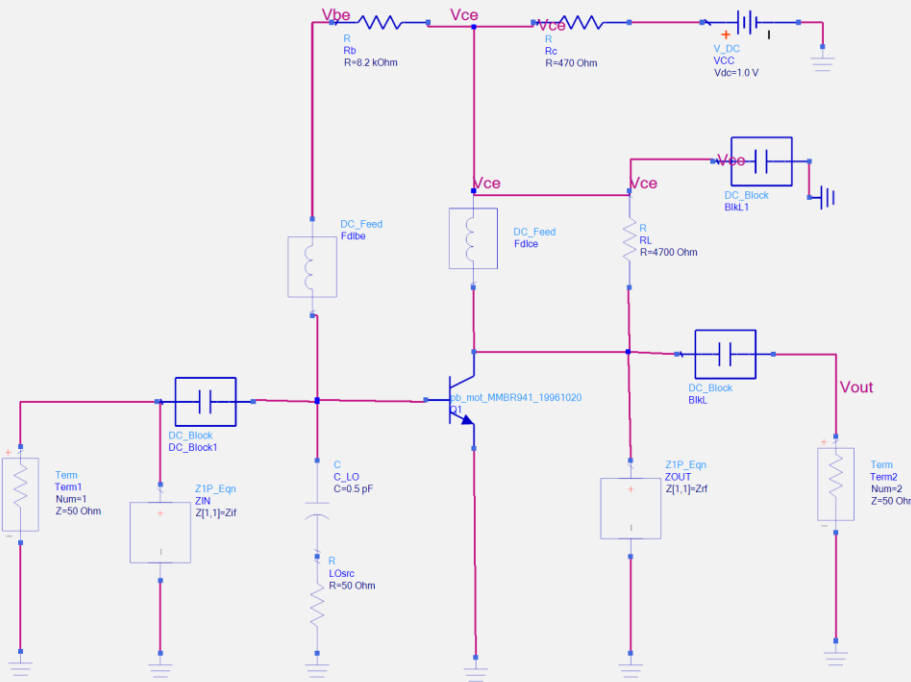

Figure 14. Calculating Device Impedance for Matching Network Design

The **Z1P_Eqn** components are defined in a VAR block. The one at the input, **ZIN**, is set to be a short-circuit at the IF and an open at the RF. This provides the required termination for **S22** at the IF, while leaving **S11** unperturbed at the RF. Similarly, **ZOUT**, at the output, is set to be a short at the RF and an open at the IF. Notice also that the LO source is represented at this point as an ideal $50\ \Omega$ termination, coupled to the mixer through a 0.5pF capacitor. The capacitor was chosen to be so small in order to isolate the LO source from the RF input signal.

The return loss looking back through the capacitor towards the LO source is only 0.33 dB at RF, so that it almost appears like an open circuit to the incoming RF signal. The penalty is that the LO, which is close in frequency to the RF, is also isolated from the circuit, meaning that a higher LO drive level is required. For example, when the LO source is set at -10 dBm, only -22 dBm reaches the mixer.

The resulting S-parameters at the RF show that the input impedance is $(11.5 - j51.4) \Omega$ with a short-circuit on the output. At the IF, the output impedance is $(2065 - j2010) \Omega$. These values can be used to decide on matching network topologies and component values. The designer always has several topologies to choose from in developing a matching network, and which one is best will depend on factors such as maximizing yield (some topologies are more sensitive to component variation than others), minimizing component count (to reduce cost) and combining functions where possible (incorporating the bias decoupling components into the matching, in this case).

- To illustrate, Figure 15, shows that, starting at the device input impedance (A), a shunt inductor followed by a series inductor will move the circuit impedance successively from B1 to 50Ω . The resulting network "A" has some advantages: the shunt inductor will provide a short to the IF at the input, as required, and it can be used in the bias decoupling network (to replace the ideal DC_feed). However, network "B" is even better: using a smaller value of shunt inductance brings the impedance to B2, where a match is achieved using a series capacitor. C1 can also serve as the DC blocking capacitor, thereby saving a component, so this network is used for the mixer. ADS provides an easy to use interactive Smith Chart tool utility that can be used for designing Matching Networks. S

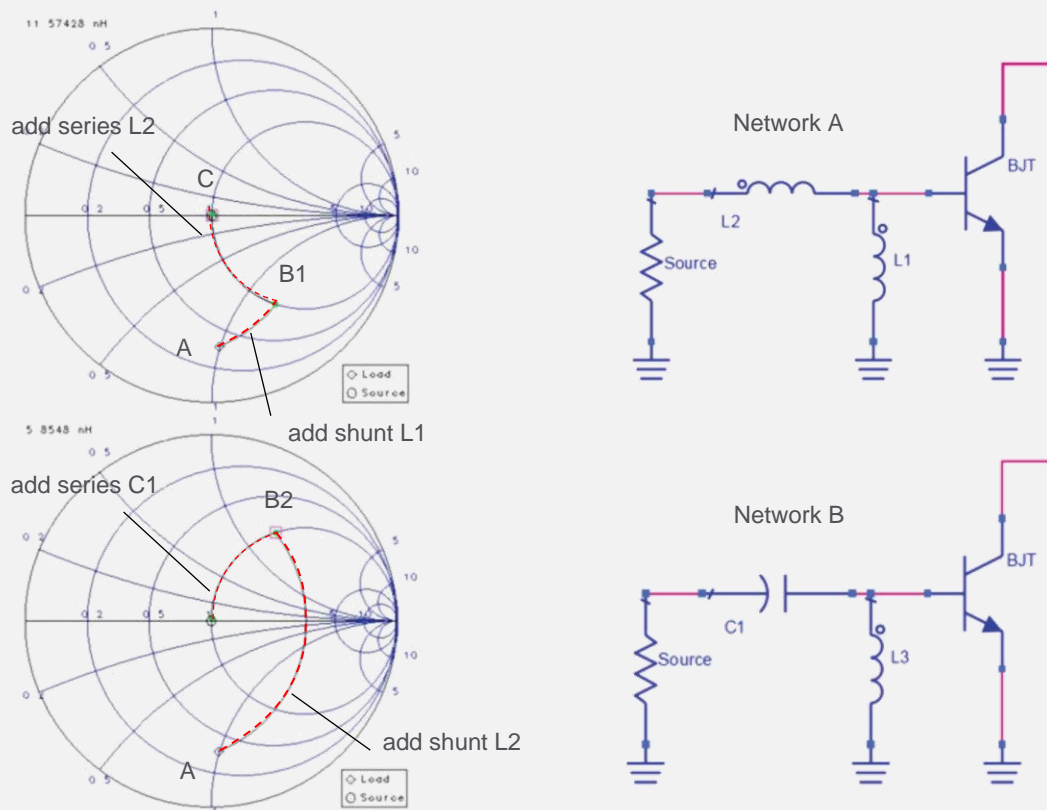

Figure 15. Choosing an Input Matching Topology

The output matching network was developed using a similar approach: starting from the Smith Chart, a matching network consisting of a shunt inductor followed by a series capacitor was designed. However, this topology would result in any RF at the output being dumped to the load instead of being short circuited as intended. To solve this, the shunt inductor (originally nearly 910 nH, a very high impedance at RF) is replaced by an equivalent parallel LC combination. The capacitor must be large enough to provide a near-short for the RF, and a value of 33 pF is chosen. The shunt inductor is then decreased, so the total reactance provided by the LC pair at the IF is the same as that of the original inductor.

Although it was not done in this example, the actual component values for the network can be calculated using ADS, as illustrated in examples like **LNA_1GHz_prj**. In this case, components were calculated manually from the Smith Chart, and the resulting circuit is shown in LOdrive, (**04_LO Drive > LOdrive > schematic**). The final matching networks are shown in Figure 16. Notice that, in addition to components for the matching and bias networks, a load resistor, R_L , has been added to control the mixer's conversion gain. The initial value of 4.7 k Ω was chosen to be high enough not to have an effect on the mixer's performance and will be adjusted as required once the conversion gain is known. Also, two large RF bypass capacitors (BkL1 and BkL2) are added to provide RF ground to the output load resistor and inductor and to the input shunt inductor, respectively.

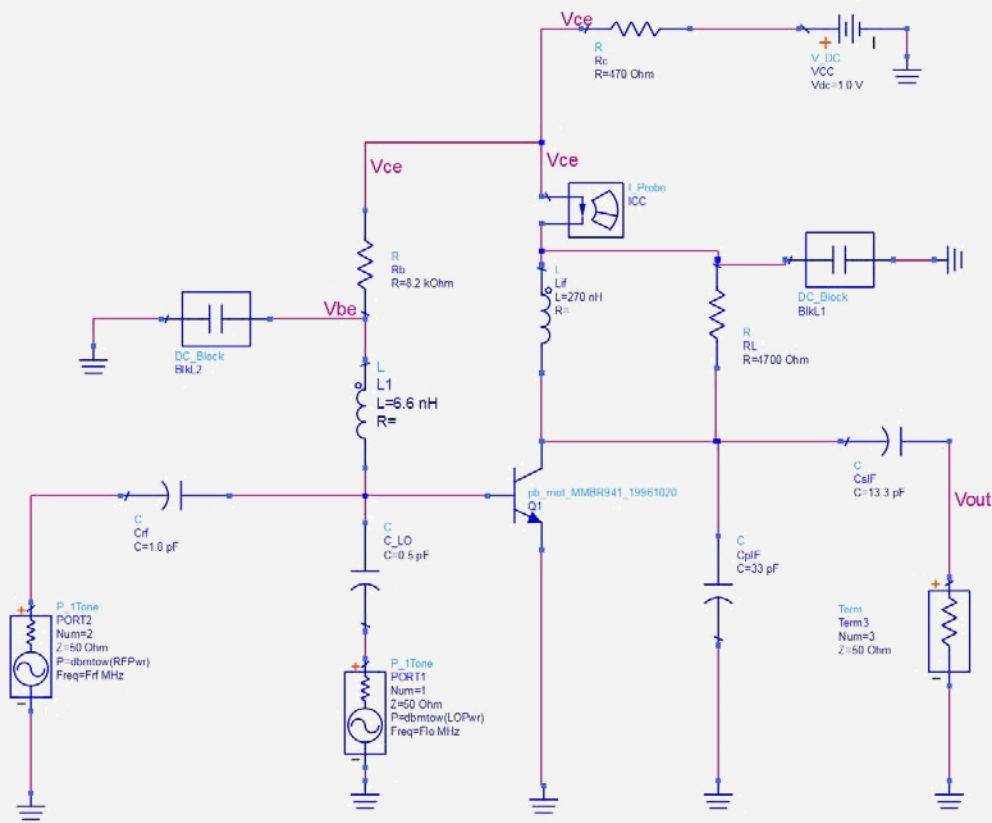

Figure 16. Mixer Matching Network

Mixer Conversion Gain Versus LO Drive Level (Cell: LOdrive)

LOdrive (04_Compression & LO Drive > LOdrive > schematic) shows how to simulate conversion gain for the mixer and how to determine the effect of LO drive level on gain and DC bias. The RF and LO frequencies and the LO power level have been defined as variables. The RF drive level is specified at -50 dBm, while the harmonic balance controller is set up to sweep the LO drive level from -30 to -5 dBm. (The controller has many parameters, and the user can control which are visible on the schematic by editing the component and choosing the “Display” page in the edit dialog window.) A simulation measurement equation defines the output power, in dBm, at the IF. Defining it here instead of the data display page makes it possible to optimize for output IF power, if needed. The “mix” function will return the component of the Vout spectrum defined by {-1, 1}, meaning {-Freq[1] + Freq[2]} or -LO + RF = IF (45 MHz).

The P_IF equation calculates the dBm value of the mix function.

The data display shows the effect of the load resistor (see Figure 17).

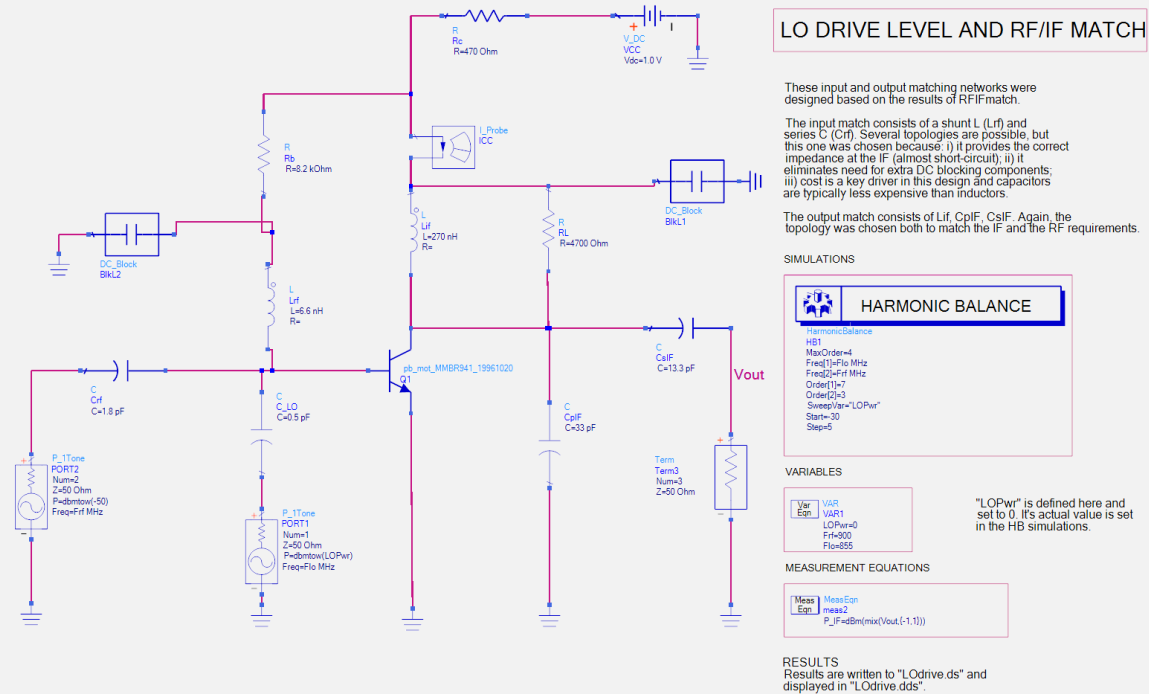

Figure 17. Setup for Swept LO Drive Level Mixer Simulation

Since the conversion gain is the difference between P_IF and the RF, and the RF power is fixed at -50 dBm, the conversion gain can be calculated with a simple expression. Note that the default dataset, LOdrive, contains results for a 4.7 kΩ load resistor, and the conversion gain for this simulation is calculated by the equation “ConvGain”. The conversion gain for a -10 dBm LO drive is 17 dB, which is unacceptably high. A second simulation was run with the load resistor reduced to 1.5 kΩ, which creates a lossy mismatch on the output. The results for that simulation were output to dataset LOdrive15, and equation “ConvGain_RI5kOhm” shows the conversion gain is reduced to 13.7 dB. This is still higher than the specification of 10 dB but will be left at this value for now since conversion gain can be expected to decrease further when non-ideal surface mount components replace the ideal components.

The second graph in the data display shown in Figure 18 illustrates the effect of the LO drive level on DC bias. Increasing the LO signal at the base drives the output swing on the collector harder, shifting the DC component higher (see Figure 19). In practice, a 5 to 15 percent shift in collector bias current typically gives good performance for a mixer of this type.

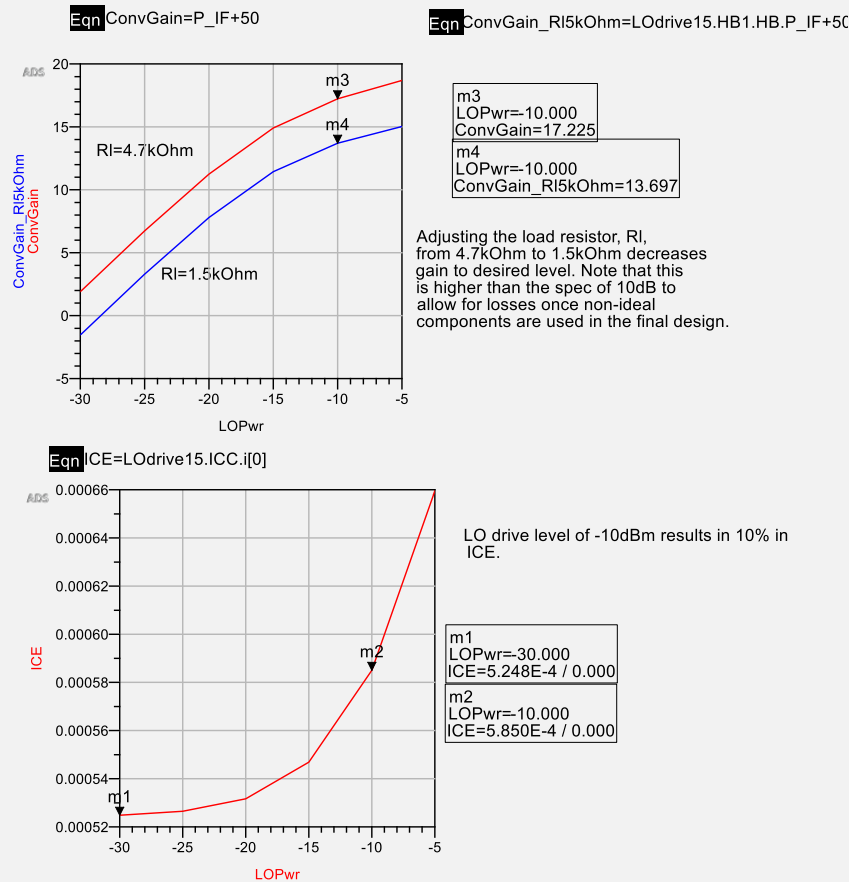

Figure 18. Conversion Gain and Bias Current Vary with LO Drive Level

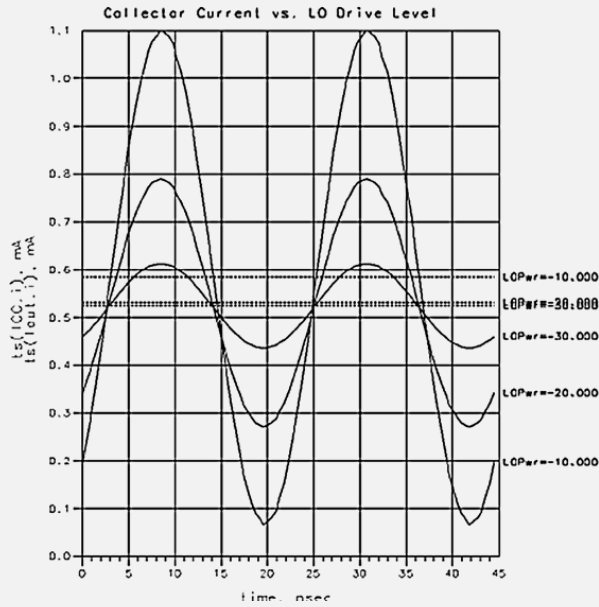

Figure 19. Variation in Output Current with LO Drive Level

Mixer Conversion Gain Versus RF Signal Level (Cell: MixCompr)

The set-up for measuring mixer compression used in **MixCompr (03_Compression & IF Match > MixCompr)** is very similar to LDrive, except that the LO power level is now held constant at -10 dBm, while the RF power is swept from -50 to 0 dBm. As the results in Figure 20 show, the mixer's conversion gain reaches 1 dB compression at an input signal level of -27 dBm.

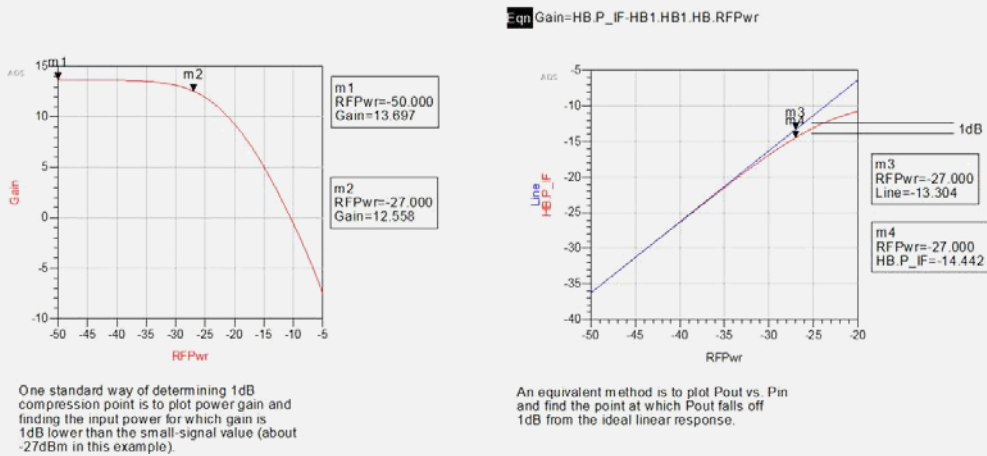

Figure 20. Mixer Conversion Gain Compression

Now that the mixer's performance is verified, the next step is to replace the ideal passive components with realistic models of the surface-mount resistors, capacitors and inductors that will be used in the actual circuit.

Creating the Mixer Layout (Cell: MixerLayout)

MixerLayout (05_Mixer Design & Sim > MixerLayout) contains a layout as well as a schematic. There are many possible ways to create layouts, and the best method will depend on the application. In this example, the first step was to convert all the components in the schematic to their nearest equivalent SMT part from the Passive Component Library. Next, these parts were placed in the layout window in their approximate locations. Interconnects were made in the layout window using the Trace command or microstrip components, and the final positioning of the components was adjusted. Finally, the schematic was updated using the design synchronization function.

MixerLayout was created by saving MixCompr under a new name and modifying it. Since the finished circuit will be simulated using the layout representation, it will have to be placed as a subnetwork in another schematic. This is because the layout file cannot contain simulator controllers, sources or terminations. The first step is to remove those components from the schematic and add ports to each point in the circuit that will be connected externally, either to sources, grounds or other circuits. The labels for each port will appear on the schematic symbol used when the design is placed in another schematic, so meaningful names should be provided. At this stage, the designer may also create a custom symbol for the circuit by selecting **View > Create/Edit Schematic Symbol**.

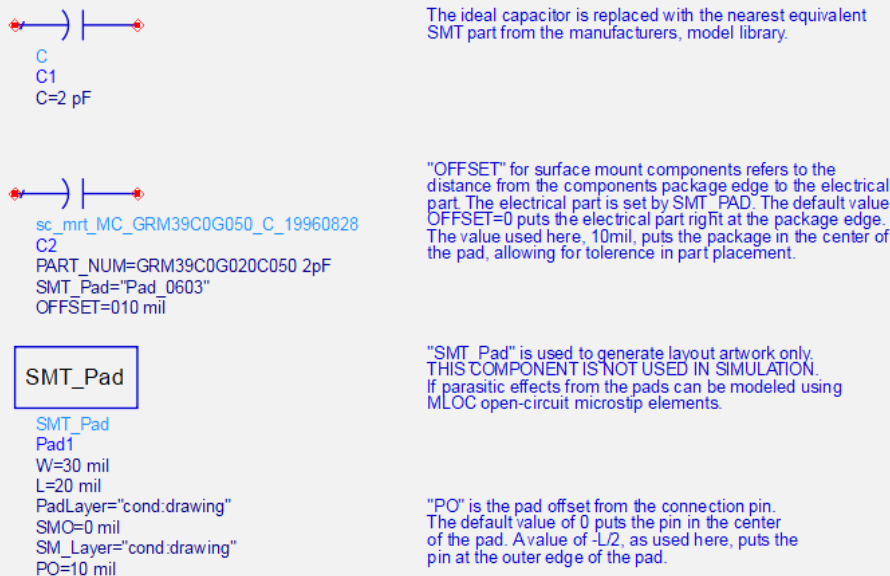

Figure 21. Substitution of SMT component for ideal component requires use of SMT_Pad

The next step is to replace each resistor, capacitor and inductor with a model of the SMT component that will be used in the actual circuit. The models are all found in the SMT Component Libraries by selecting the Browse and Search function in the Component Library List window. In this case, all the capacitors are MuRata Erie parts: the matching and bias capacitors are all MuRata Erie series GRM39 parts, while the RF bypass capacitors are GRM36 series. The resistors are taken from the Dale CRCW series and the inductors are Coilcraft parts.

Where possible, parts are chosen to have a standard 0.060"x 0.030" footprint, although the inductors and RF bypass capacitors have different dimensions. Note that each SMT component specifies the name of the SMT_Pad component it uses. This SMT_Pad defines the pad-size to be used in layout, as shown in Figure 21. The designer must define these on the schematic page to ensure the pads appear correctly in the layout. Since each user will define the pads to suit their own board-fabrication process, the models do not include pad characteristics.

Once the components are placed and the pads defined, the designer can select **Layout > Place Components** from Schematic to Layout and place each part in its approximate location in the layout window. Traces are a convenient way to create the interconnects. They can be converted to equivalent microstrip components using the **Edit > Path/Trace/Convert Traces** command. In general, when moving back and forth between the schematic and layout representations, it is best to work on small sub-sections and synchronize the two representations manually. Synchronization ensures that both layout and schematic describe the same circuit: for example, if the designer has made some changes to the layout, the schematic can be updated to reflect them by selecting **Schematic > Generate/Update Schematic** in the layout window. Changes made to the schematic can be similarly transferred to the layout by choosing **Layout > Generate/Update Layout** in the schematic window.

Figure 22 shows the finished layout. A ground-plane has been added to the top-side metallization to eliminate the need for vias, thus reducing fabrication costs. This can be easily created in ADS by drawing a rectangle the size of the final circuit board and using the **Edit > Create Clearance** feature to generate the required spacing around transmission lines and component footprints.

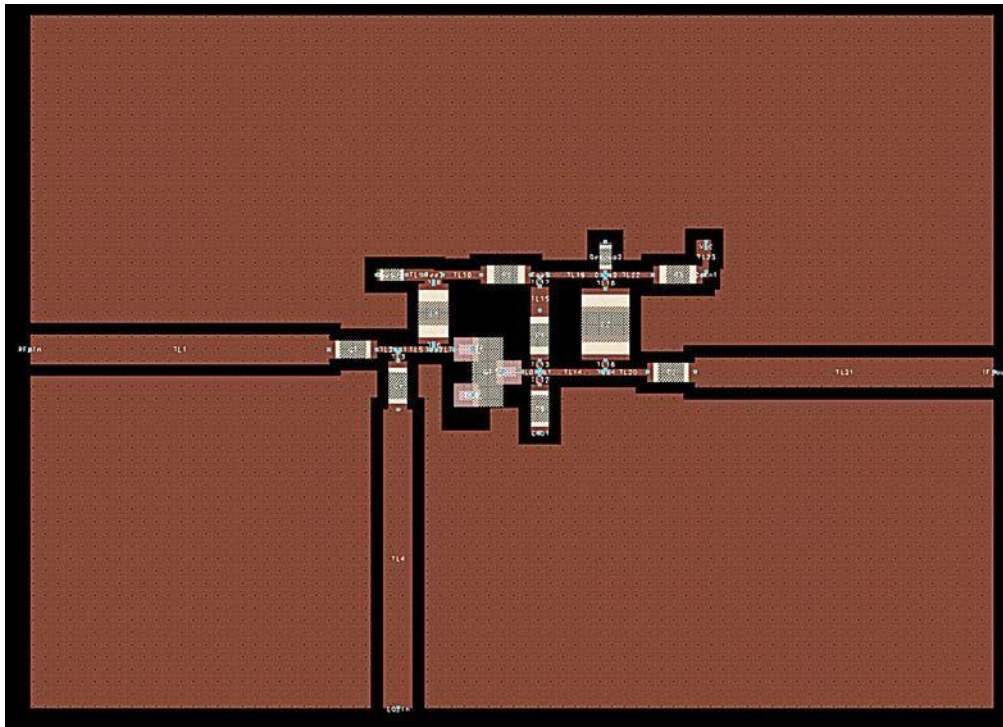

Figure 22. Finished Layout for Mixer Circuit

Finally, in this example the design will be simulated from layout, so the “SimLay” option is selected in the **File > Design/Parameters** dialog box. This allows the designer to see the effects of changes in the layout directly, without having to re-enter parameters in the schematic. Notice that components in the schematic can be modified (or even deleted entirely) without affecting the simulation, as long as the layout remains intact.

Simulation from Layout (Cell: SimFromLayout)

SimFromLayout (05_Mixer Design & Sim > SimFromLayout > schematic) contains MixerLayout, together with the simulation controller, sources and terminations required to simulate it. The simulation setup is identical to the one used in LDrive so the results using the non-ideal components may be compared directly. MixerLayout uses microstrip lines, so an “MSub” component is also included (Figure 23).

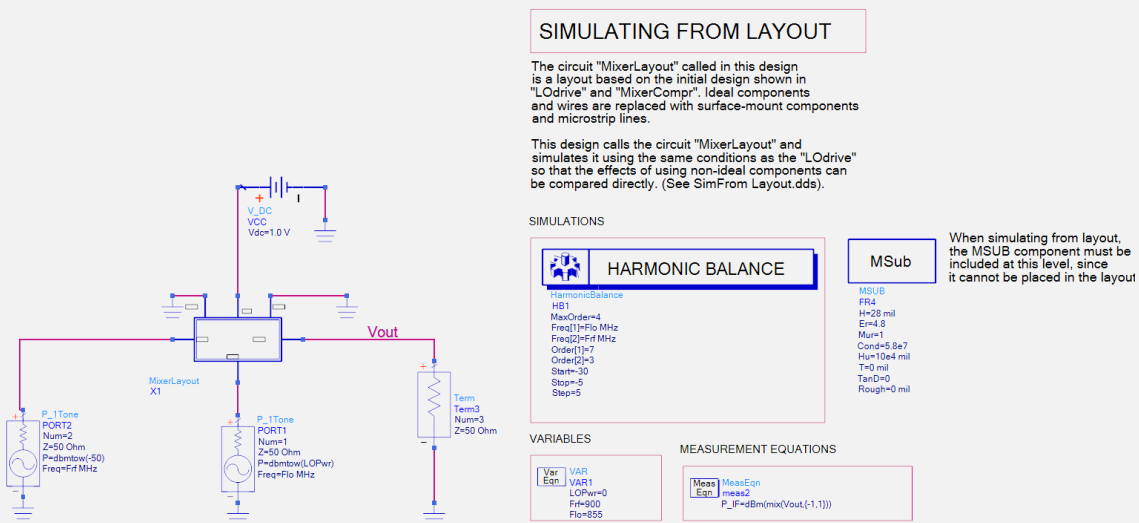

Figure 23. MixerLayout called as a sub-network in SimFromLayout

Figure 24 shows the mixer conversion gain as a function of LO drive level when simulated using both the ideal components and the SMT model components. As expected, the conversion gain has drops significantly, due mainly to the resistive losses in the inductors. This can be verified by replacing individual components with their ideal counterparts and re-simulating. The load resistor can now be adjusted to compensate for these losses:

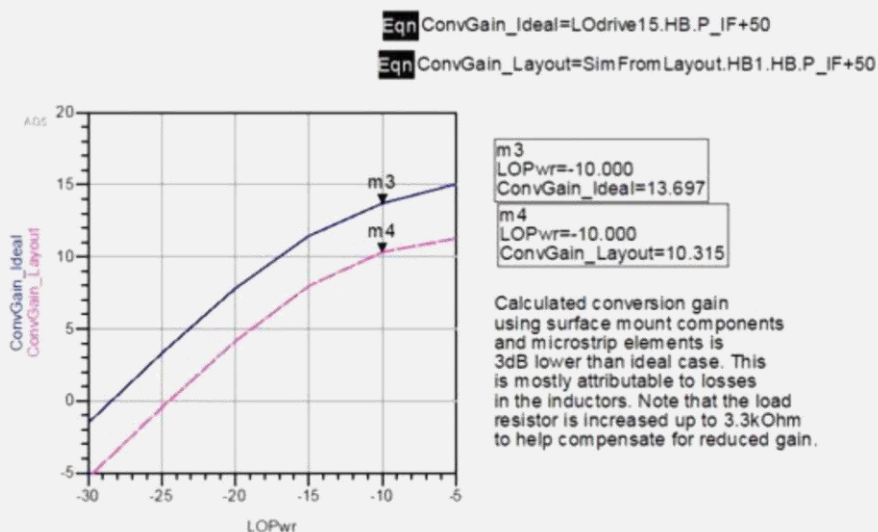

Figure 24. Comparison of Mixer Conversion Grain using Ideal and SMT Components

Changing RI from 1.5 k Ω to 3.3 k Ω restores the simulated conversion gain to 10.76 dB, providing a 0.76 dB margin over the specification. Note that these changes must be made in the layout file in order to be reflected in the simulation results. Once any such final corrections have been made to the layout, the circuit board is ready to be exported for fabrication.

Conclusion

An example mixer design using Keysight ADS has been presented, including details of the design process and simulation set-ups. This example is included with Keysight ADS and can be readily copied and modified by users for their own projects.

Additional material and various Mixer design examples can be found at the Keysight EEsof EDA Knowledge Center: <http://www.keysight.com/find/eesof-knowledgecenter>

Congratulations! You have completed Active Mixer Design. Check out more examples: <http://www.keysight.com/find/eesof-ads-rfmw-examples>

Learn more at: www.keysight.com

For more information on Keysight Technologies' products, applications or services, please contact your local Keysight office. The complete list is available at: www.keysight.com/find/contactus

