

Keysight TC721

DC–50 GHz Variable Attenuator: Switching Speed Limitations

Technical Overview

Introduction

The TC721 is a voltage variable attenuator that operates from DC to 50 GHz. This application note highlights the switching speed limitations of the TC721, including temperature effects on switching speed.

Switching Speed Limitations

There is a well known GaAs anomaly called “slow tails” or “gate lag.” The effect of this anomaly is that the drain current (and therefore, the channel resistance) does not have the same switching profile as the signal that was applied to the gate. The difference in the two profiles is seen in the settling time where there may be a time constant in the rise or fall time. Gate lag is believed to be due to surface states that exist near the edges of the gate. Since these surface states are not completely controlled, the occurrence of gate lag is also not controlled. Worse case conditions for gate lag occur when the gate is switched from beyond pinchoff to the ON state. On a single FET, the magnitude of the gate lag is dependent on how far beyond pinchoff the initial gate voltage is and how far ON the second voltage is switched to. The wider the swing across pinchoff, the higher the gate lag can be. Temperature can also affect the amount of gate lag. The colder the temperature, the higher the gate lag will be.

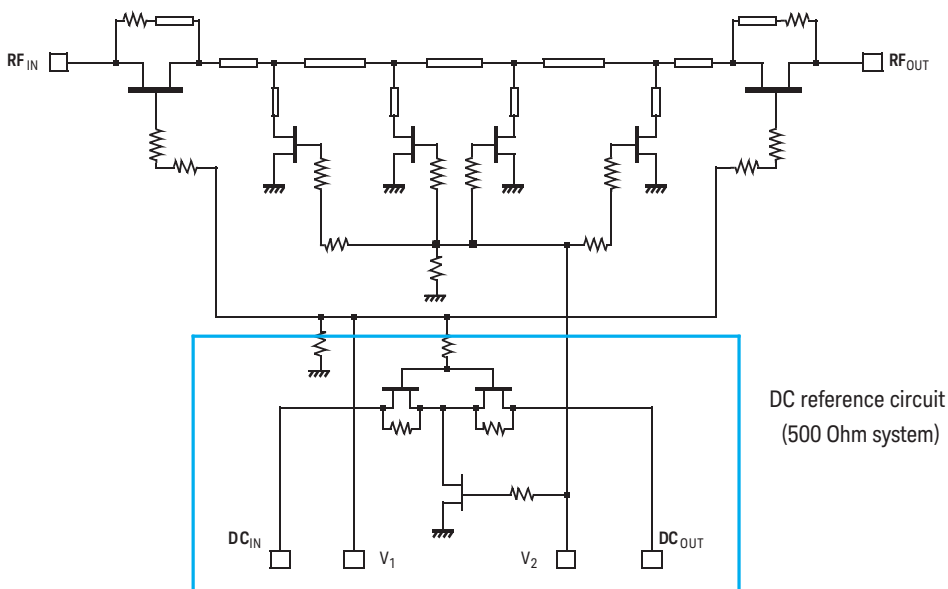

Figure 1. TC721 Schematic

For FET attenuators, gate lag causes slow responses in channel resistance, and when the channel resistance is slow to change, so is the attenuation level. For the TC721, this limitation is evident when switching from minimum attenuation to other attenuation levels (see Figures 2 and 3). Not all attenuation levels were tested, but the data suggests that all levels are affected. No gate lag was observed when switching from maximum attenuation to minimum, or when switching from other attenuation levels to minimum. This suggests that the shunt FET is the main cause of gate lag in the TC721. The theory suggests that gate lag may exist when switching from maximum to minimum due to the fact that the series FETs are being switched from –4 volts on the gate to 0 volts on the gate. However, any gate lag generated by the series FETs is expected to be very small due to the presence of the 50 ohm shunt resistors that are across each series FET. This resistor causes the equivalent series resistance to be buffered from changes in resistance that occur in the FET. Also, for a “T” attenuator, the attenuation level is more sensitive to shunt resistance changes than for series resistance changes. This explains why the TC721 only shows gate lag effects when going from lower attenuations to higher attenuations.

The switching speed is also affected by temperature. The colder the temperature the greater the effect. Data has shown that for some devices, gate lag will only be evident at temperatures below room temperature.

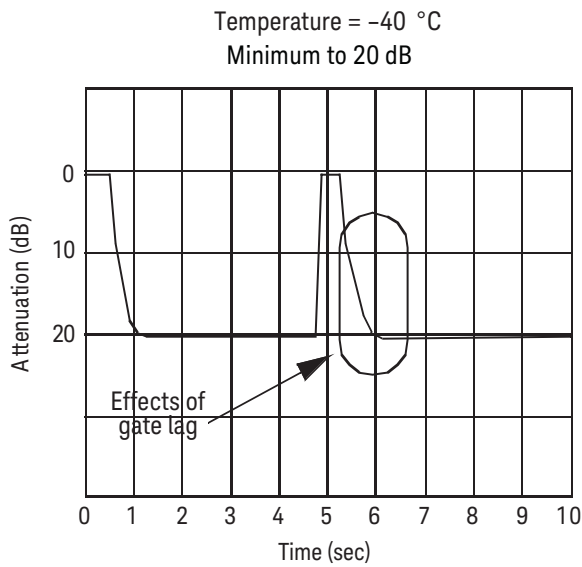

Figure 2. TC721 Switching Speed Minimum to 20 dB Level

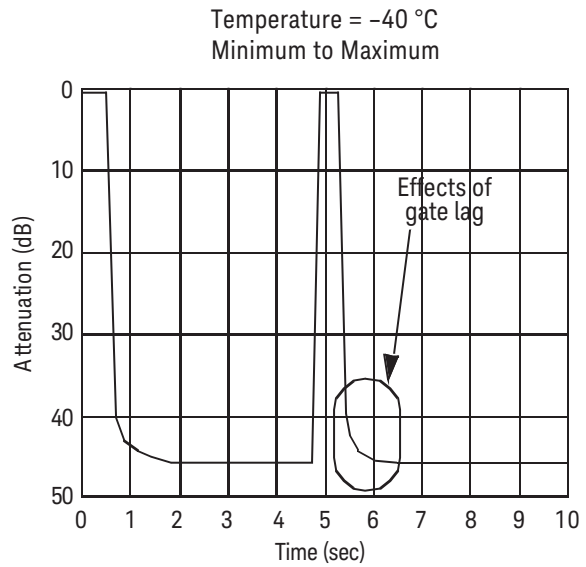

Figure 3. TC721 Switching Speed Minimum to Maximum Level

myKeysight

myKeysight

www.keysight.com/find/mykeysight

A personalized view into the information most relevant to you.



www.axistandard.org

AdvancedTCA® Extensions for Instrumentation and Test (AXIe) is an open standard that extends the AdvancedTCA for general purpose and semiconductor test. Keysight is a founding member of the AXIe consortium. ATCA®, AdvancedTCA®, and the ATCA logo are registered US trademarks of the PCI Industrial Computer Manufacturers Group.



www.lxistandard.org

LAN eXtensions for Instruments puts the power of Ethernet and the Web inside your test systems. Keysight is a founding member of the LXI consortium.



www.pxisa.org

PCI eXtensions for Instrumentation (PXI) modular instrumentation delivers a rugged, PC-based high-performance measurement and automation system.



Three-Year Warranty

www.keysight.com/find/ThreeYearWarranty

Keysight's commitment to superior product quality and lower total cost of ownership. The only test and measurement company with three-year warranty standard on all instruments, worldwide.



Keysight Assurance Plans

www.keysight.com/find/AssurancePlans

Up to five years of protection and no budgetary surprises to ensure your instruments are operating to specification so you can rely on accurate measurements.



www.keysight.com/quality

Keysight Technologies, Inc.
DEKRA Certified ISO 9001:2008
Quality Management System

Keysight Channel Partners

www.keysight.com/find/channelpartners

Get the best of both worlds: Keysight's measurement expertise and product breadth, combined with channel partner convenience.

www.keysight.com/find/mmic

For more information on Keysight Technologies' products, applications or services, please contact your local Keysight office. The complete list is available at: www.keysight.com/find/contactus

Americas

Canada	(877) 894 4414
Brazil	55 11 3351 7010
Mexico	001 800 254 2440
United States	(800) 829 4444

Asia Pacific

Australia	1 800 629 485
China	800 810 0189
Hong Kong	800 938 693
India	1 800 112 929
Japan	0120 (421) 345
Korea	080 769 0800
Malaysia	1 800 888 848
Singapore	1 800 375 8100
Taiwan	0800 047 866
Other AP Countries	(65) 6375 8100

Europe & Middle East

Austria	0800 001122
Belgium	0800 58580
Finland	0800 523252
France	0805 980333
Germany	0800 6270999
Ireland	1800 832700
Israel	1 809 343051
Italy	800 599100
Luxembourg	+32 800 58580
Netherlands	0800 0233200
Russia	8800 5009286
Spain	0800 000154
Sweden	0200 882255
Switzerland	0800 805353
	Opt. 1 (DE)
	Opt. 2 (FR)
	Opt. 3 (IT)
United Kingdom	0800 0260637

For other unlisted countries:
www.keysight.com/find/contactus
(BP-07-01-14)

