

Keysight Technologies

8767/8/9M Microwave Single-Pole Multi-Throw Switches

for Microwave and RF Manufacturing Test Systems

Product Overview

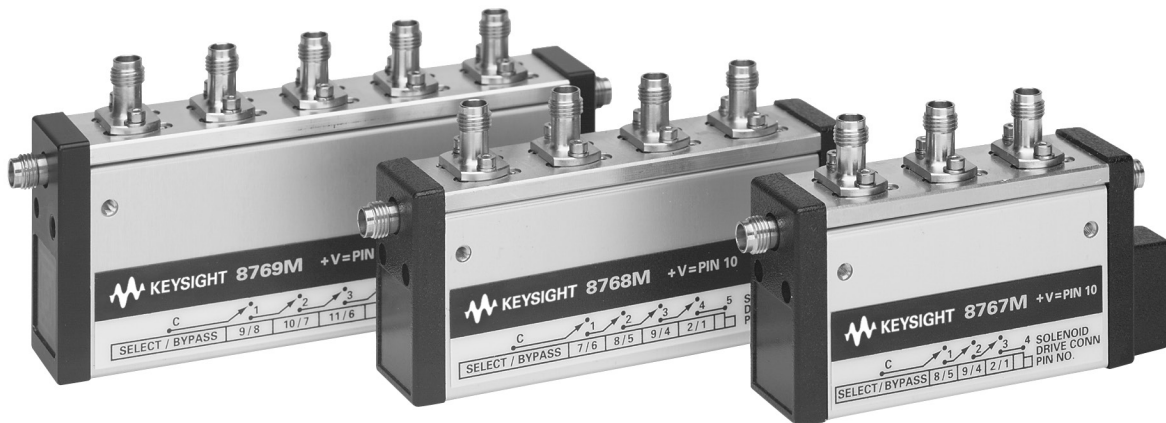

Features and description

- Excellent repeatability:
<0.03 dB typical
- Low SWR:
<2.1 @ 50 GHz (8767M)
- Low insertion loss:
<2.6 dB @ 50 GHz (8767M)
- Long life: >5 million cycles
- DC to 50 GHz
- Compact
- Easy GPIB implementation for ATE applications
- Single-pole, multiple-throw models available:
 - four-throw (8767M)
 - five-throw (8768M)
 - six-throw (8769M)

In today's fast moving technical industries, test engineers need components they can count on. Keysight Technologies, Inc. now offers an extension to its existing single-pole, multiple-throw switches that combine its legendary reliability with a higher frequency (50 GHz) capability.

Reduce downtime

Keysight is the world leader in innovating and developing microwave accessories for communications and aerospace applications. Our innovative design and strict adherence to quality process control ensure that each switch is guaranteed to perform within warranted specifications for its entire lifetime. With fewer breakdowns and less need to recalibrate, your test platform performs better with less downtime, creating more throughput and revenue.

Raise your standards

All Keysight switches offer excellent repeatability and long life – up to five times the lifecycles of the competition. Along with our aggressive specifications for isolation, SWR, and insertion loss, you have a switch that will exceed the expectations of even the most demanding engineer with its precision and durability.

Increase productivity

When you buy your switches from Keysight, you will notice a difference. Your test platforms will run smoother, longer, and faster, while yielding more viable and valuable measurements.

Description

This Keysight family of single-pole, multiple-throw switches utilizes the same technology as the Keysight 8490X family of step attenuators. These products offer the same rugged reliability, excellent repeatability (typically 0.03 dB to 50 GHz), long life (greater than 5 million switching cycles), compactness, and broadband performance as the 8490X family. Each product consists of 3 to 5 solenoid driven switching sections connected in series. The solenoid armatures are held in place with permanent magnets, able to withstand shocks to over 10 Gs.

The sections switch within 20 milliseconds, including contact settling time, which is important for automatic test applications. The switches include self-interrupting contacts which minimize power consumption and simplify the driver circuit design (See figure 1). Each model is available with a range of solenoid voltage options (24, 5 or 15 volts) to match your product or system's requirements.

Section switching

Figure 1 shows one switching section schematic. Each section utilizes one solenoid with dual coil windings, one coil to switch in the RF connector, and one coil to switch in the thru line.

With a positive voltage applied to the common pin, the state (RF connector or thru line) of a particular section is driven by connecting its RF connector pin to a negative voltage ground. Tables 1 through 3 define the pin assignments for the different switches.

As a section is switched, the internal contacts of the activated coil open, thus shutting off current flow. At the same time, the internal contacts for the other coil close so that it can be activated when desired. Figure 1 shows a section that has been switched to the RF connector position (note the closed thru line coil contact). The switching is “break-before-make” type, thus a momentary interruption of the RF signal occurs at switching.

Although all sections can be switched simultaneously, the attenuator drive must not allow both pins of the same section (e.g., Section 1, pins 5 and 6) to be activated concurrently, or else that section would cycle rapidly. All terminals are “floating,” so bipolar or unipolar power supplies may be used.

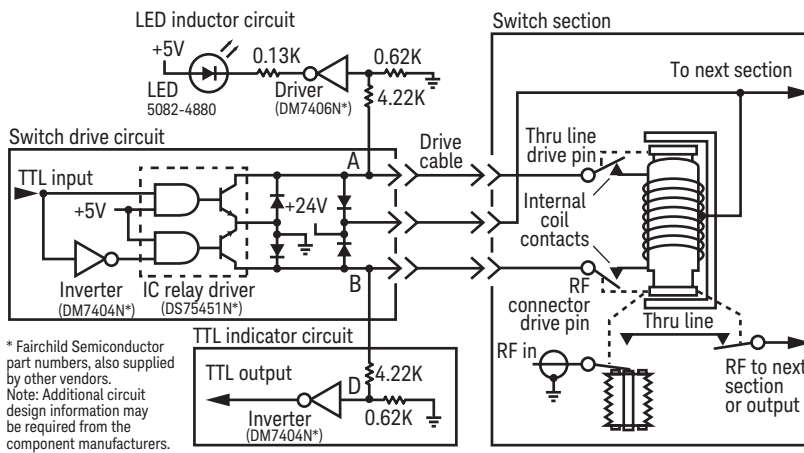

Figure 1: Driver and indicator circuits for one section of an Keysight 8494/5/6/7

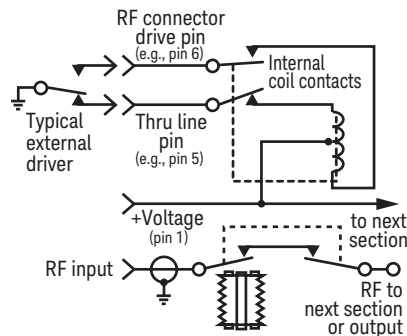

Figure 2: Port electrical diagram

Typical driver circuit

Figure 1 shows an economical TTL compatibility driver circuit for a single attenuation section that utilizes an IC relay driver and an inverter. A TTL “HI” input to the driver switches in the desired port, while a “LO” will activate the thru line for that section. This provides a complimentary driver for the section that assures that only one solenoid of the pair is activated at a time.

Switch position can be indicated remotely by utilizing the open and closed states of the internal coil contacts. Connected at A and B in Figure 1 are two indicator circuits, one providing a TTL output and one that activates an LED. These circuits will output a TTL “HI” (LED lamp “ON”) if the desired port is in the RF circuit, and will output a TTL “LO” (LED lamp “OFF”) if the thru line is in the RF circuit. Since current is drawn through the coil for these circuits, inadvertent switching is prevented by limiting the current to 5 mA.

Keysight assumes no responsibility for the use of any circuits described herein and makes no representation or warranties, express or implied, that such circuits are free from patent infringement.

GPIB attenuator/switch driver

Employing programmable step attenuators and switches in an automatic test system becomes an easy task when the Keysight 11713A attenuator/switch driver or 87130A attenuator/switch driver is specified into the system. The 11713A has all of the necessary features to provide GPIB control of up to ten switching sections of the 8766/7/8/9 series switches (e.g., three 8767M, two 8768M, etc.).

The 11713A includes an integral power supply (with short circuit protection) that can simultaneously provide 125 milliamps at 24 volts to all contacts for control of the attenuators and switches, so no external power supply is needed. Each 11713A is provided with two (2) plug-in drive cables for the programmable switches to simplify connection to the driver.

The 11713A also features convenient front panel keys so the user can manually activate the individual switch sections when in the “local” mode. Switching time for the drivers is less than 10 milliseconds.

The 87130A is a 3.5 inch high, full width System II attenuator/switch driver capable of driving up to 248 bistatic electromechanical switch or attenuator sections. The 87130A is controlled over GPIB via standard commands for programmable instruments (SCPI) commands. The 87130A has been designed for use in both ATE switching systems and computer controlled bench top applications.

More configuration details are available on the Keysight 11713A and 87130A in the Product Overview, literature number 5963-2038E.

Isolation and insertion loss

Isolation and insertion loss varies with frequency and depends on the port selected, as shown in the chart and tables below. The input connector “C” is always defined as the connector at the opposite end of the switch from the DC drive cable. The output ports are numbered sequentially from the input connector.

Table 1. Keysight 8767M with switch profile and connector pin assignments

Section:	Port 1		Port 2		Port 3		+Voltage supply
Model number	Thru line	port conn	Thru line	port conn	Thru line	port conn	
8767M							
Switch actuating pin	5	8	4	9	1	2	10
11764-60001 Pin dip connector color	GRN	GRAY	YEL	WHT	BRN	RED	BLK
11764-60004 Viking plug pin number	7	8	9	10	5	6	1
11764-60002/60003 flat header pin number	11	5	3	9	13	2	6

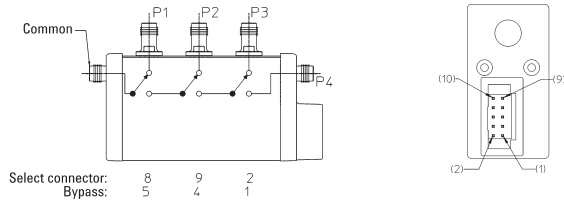

Table 2. Keysight 8768M with switch profile and connector pin assignments

Section:	Port 1		Port 2		Port 3		Port 4		+Voltage supply
Model number	Thru line	port conn	Thru line	port conn	Thru line	port conn	Thru line	port conn	
8768M									
Switch actuating pin	6	7	5	8	4	9	1	2	10
11764-60001 Pin dip connector color	BLU	VIO	GRN	GRAY	YEL	WHT	BRN	RED	BLK
11764-60004 Viking plug pin number	11	12	7	8	9	10	5	6	1
11764-60002/60003 flat header pin number	4	10	11	5	3	9	13	2	6

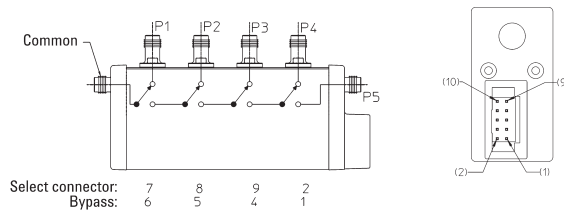
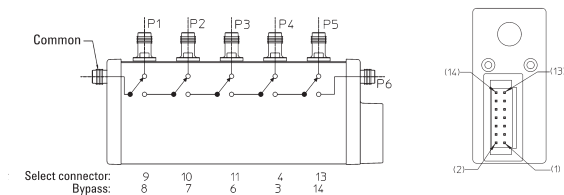

Table 3. Keysight 8769M with switch profile and connector pin assignments

Section:	Port 1		Port 2		Port 3		Port 4		Port 5		+Voltage supply
Model number	Thru line	port conn	Thru line	port conn	Thru line	port conn	Thru line	port conn	Thru line	port conn	
8769M											
Switch actuating pin	8	9	7	10	6	11	3	4	14	13	12
5064-7851 Pin dip connector color	GRAY	WHT	VIO	BLK	BLU	BRN/WHT	ORG	YEL	YEL/WHT	ORG/WHT	RED/WHT
5064-7848 Viking plug pin number	11	12	7	8	9	10	5	6	4	3	1
5061-0957/0958 flat header pin number	4	10	11	5	3	9	13	2	7	8	6



Specifications

Insertion loss, dB	8767M (1x4)		8768M (1x4)		8769M (1x4)	
	DC - 40 GHz	40 - 50 GHz	DC - 40 GHz	40 - 50 GHz	DC - 40 GHz	40 - 50 GHz
C to 1	.4 + .025*f	1.8	.4 + .025*f	1.8	.4 + .025*f	1.8
C to 2	.5 + .03*f	2.2	.5 + .03*f	2.2	.5 + .03*f	2.2
C to 3	.6 + .03*f	2.6	.6 + .03*f	2.6	.6 + .03*f	2.6
C to 4	.6 + .03*f	2.6	.8 + .04*f	3.0	.8 + .04*f	3.0
C to 5			.8 + .04*f	3.0	1 + .05*f	3.4
C to 6					1 + .05*f	3.4

NOTE: At 75 °C, increase insertion loss by .006*f (where f = frequency in GHz)

Isolation, min (dB)	8767M	8768M	8769M	Relevant port location
(f = freq. in GHz)	35 - .25*f	35 - .25*f	35 - .25*f	Lower number ports
(f = freq. in GHz)	70 - .5*f	70 - .5*f	70 - .5*f	Higher number ports

Maximum SWR:	Frequency (Ghz)			
	DC - 12.4	12.4 - 34.0	34.0 - 40.0	40.0 - 50.0
8767M	1.35	1.8	1.9	2.3
8768M	1.35	1.8	1.9	2.3
8769M	1.35	1.8	1.9	2.3 (2.6 for path C to 6 only)

RF Input power (maximum)

1 Watt average, 100 Watts peak
(10 microseconds pulse width)

Life (minimum)

5 million cycles per port

Repeatability

0.03 dB, typical to 50 GHz

Environmental capabilities

(Up to 5 million cycles)

Temperature, operating

-20 °C to +75 °C

Temperature, non-operating

-55 °C to +85 °C

Altitude, operating

4,570 meters (15,000 feet)

Altitude, non-operating

13,700 meters (50,000 feet)

Humidity

Cycling 10 days, 65 °C at 95% RH

Shock, operating

10 Gs, 6 ms, on six sides, three blows

Shock, non-operating

500 Gs, 0.5 ms, in six directions

Vibration, operating

5 Gs, 34-500 Hz;
2 Gs, 500-2000s Hz

EMC

Radiated interference is within the requirements of MIL-STD-461 method RE02, VDE 0871 and CISPR Publication II

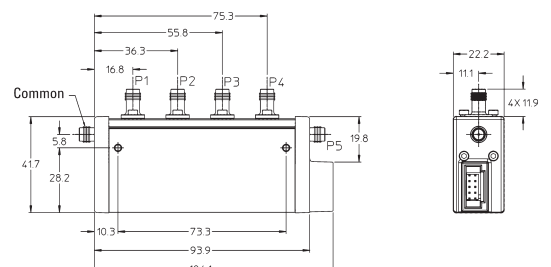
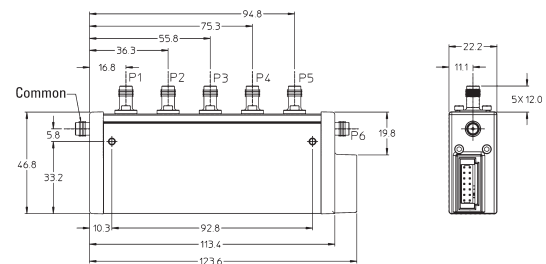
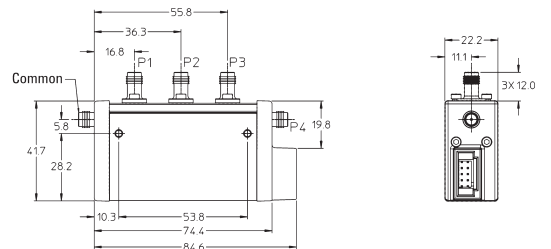

Mechanical information

Net weight	8767M	8768M	8769M
	273 grams	292 grams	349 grams
	(8.3 oz)	(12.3 oz)	(15.4 oz)

Mounting position

For any orientation, holes are threaded for a metric screw (m 3 x .5 x 5.1)

RF connectors

2.4mm female connectors (Option 101)
2.4mm female and 2.4 mm male (Option 100)

Switching speed

20 milliseconds including settling time (maximum)

Solenoids	Coil voltage	Switching current	Nominal coil impedance
Option 024	24 V (20 to 30 V)	125 mA (at 24 V)	185 Ohms
Option 015	15 V (13 to 22 V)	188 mA (at 15 V)	80 Ohms
Option 011	5 V (4.5 to 7 V)	325 mA (at 5 V)	17 Ohms

Switching current is current per section; approximately 8 ms duration before internal contacts open the coil circuit

Ordering information

8767M	Single-pole, four-throw
8768M	Single-pole, five-throw
8769M	Single-pole, six-throw

Options

Option	Description
011	5 volt solenoids
015	15 volt solenoids
024	24 volt solenoids
100	2.4 mm female connector on dc drive cable end, 2.4 mm male connector on opposite end
101	2.4 mm female connector on dc drive cable end, 2.4 mm female connector on opposite end
UK6	Calibration data (SWR and insertion loss data measurements traceable to NIST)

Accessories

Model number	Description
(8767M/8768M) 11764-60001	10-pin dip plug (for attenuator connection) to 1524 mm (5-foot) ribbon cable (no second connector)
11764-60002	203 mm (8-inch) ribbon cable with 14-pin headers, female 10-pin receptacle (for attenuator connection)
11764-60003	406 mm (16 inch) ribbon cable with 14-pin headers, female 10-pin receptacle (for attenuator connection)
11764-60004	Interconnect cable 10-pin dip plug (for attenuator connection) to "Viking" connector (for 11713A connection) for use with a 11713A attenuator/switch driver
(8769M) 5064-7851	14-pin dip plug (for attenuator connection) to 1524 mm (5-foot) ribbon cable (no second connector)
5061-0957	203 mm (8-inch) ribbon cable with 14-pin headers, female 14-pin receptacle (for attenuator connection)
5061-0958	406 mm (16 inch) ribbon cable with 14-pin headers, female 14-pin receptacle (for attenuator connection)
5064-7848	Interconnect cable 14-pin dip plug (for attenuator connection) to "Viking" connector (for 11713A connection) for use with a 11713A attenuator/switch driver

Evolving Since 1939

Our unique combination of hardware, software, services, and people can help you reach your next breakthrough. We are unlocking the future of technology.

From Hewlett-Packard to Agilent to Keysight.



For more information on Keysight Technologies' products, applications or services, please contact your local Keysight office. The complete list is available at:

www.keysight.com/find/contactus

Americas

Canada	(877) 894 4414
Brazil	55 11 3351 7010
Mexico	001 800 254 2440
United States	(800) 829 4444

Asia Pacific

Australia	1 800 629 485
China	800 810 0189
Hong Kong	800 938 693
India	1 800 11 2626
Japan	0120 (421) 345
Korea	080 769 0800
Malaysia	1 800 888 848
Singapore	1 800 375 8100
Taiwan	0800 047 866
Other AP Countries	(65) 6375 8100

Europe & Middle East

Austria	0800 001122
Belgium	0800 58580
Finland	0800 523252
France	0805 980333
Germany	0800 6270999
Ireland	1800 832700
Israel	1 809 343051
Italy	800 599100
Luxembourg	+32 800 58580
Netherlands	0800 0233200
Russia	8800 5009286
Spain	800 000154
Sweden	0200 882255
Switzerland	0800 805353
	Opt. 1 (DE)
	Opt. 2 (FR)
	Opt. 3 (IT)
United Kingdom	0800 0260637

For other unlisted countries:

www.keysight.com/find/contactus
(BP-9-7-17)

DEKRA Certified
ISO 9001 Quality Management System

www.keysight.com/go/quality
Keysight Technologies, Inc.
DEKRA Certified ISO 9001:2015
Quality Management System

myKeysight

myKeysight

www.keysight.com/find/mykeysight

A personalized view into the information most relevant to you.

http://www.keysight.com/find/emt_product_registration

Register your products to get up-to-date product information and find warranty information.

KEYSIGHT SERVICES

Accelerate Technology Adoption.
Lower costs.

Keysight Services

www.keysight.com/find/service

Keysight Services can help from acquisition to renewal across your instrument's lifecycle. Our comprehensive service offerings—one-stop calibration, repair, asset management, technology refresh, consulting, training and more—helps you improve product quality and lower costs.



Keysight Assurance Plans

www.keysight.com/find/AssurancePlans

Up to ten years of protection and no budgetary surprises to ensure your instruments are operating to specification, so you can rely on accurate measurements.

Keysight Channel Partners

www.keysight.com/find/channelpartners

Get the best of both worlds: Keysight's measurement expertise and product breadth, combined with channel partner convenience.

