

Startup
Guide

Keysight M9451A
PXIe
Measurement
Accelerator

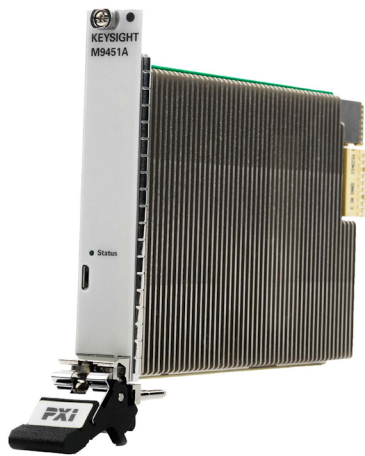

Notices

Copyright Notice

© Keysight Technologies 2015

No part of this manual may be reproduced in any form or by any means (including electronic storage and retrieval or translation into a foreign language) without prior agreement and written consent from Keysight Technologies, Inc. as governed by United States and international copyright laws.

Manual Part Number

M9451-90001

Published By

Keysight Technologies
Ground Floor and Second Floor, CP-11
Sector-8, IMT Manesar – 122051
Gurgaon, Haryana, India

Edition

Edition 1, August, 2015
Printed In Malaysia

Regulatory Compliance

This product has been designed and tested in accordance with accepted industry standards, and has been supplied in a safe condition. To review the Declaration of Conformity, go to <http://www.keysight.com/go/conformity>.

Warranty

THE MATERIAL CONTAINED IN THIS DOCUMENT IS PROVIDED “AS IS,” AND IS SUBJECT TO BEING CHANGED, WITHOUT NOTICE, IN FUTURE EDITIONS. FURTHER, TO THE MAXIMUM EXTENT PERMITTED BY APPLICABLE LAW, KEYSIGHT DISCLAIMS ALL WARRANTIES, EITHER EXPRESS OR IMPLIED, WITH REGARD TO THIS MANUAL AND ANY INFORMATION CONTAINED HEREIN, INCLUDING BUT NOT LIMITED TO THE IMPLIED WARRANTIES OF MERCHANTABILITY AND FITNESS FOR A PARTICULAR PURPOSE. KEYSIGHT SHALL NOT BE LIABLE FOR ERRORS OR FOR INCIDENTAL OR CONSEQUENTIAL DAMAGES IN CONNECTION WITH THE

FURNISHING, USE, OR PERFORMANCE OF THIS DOCUMENT OR OF ANY INFORMATION CONTAINED HEREIN. SHOULD KEYSIGHT AND THE USER HAVE A SEPARATE WRITTEN AGREEMENT WITH WARRANTY TERMS COVERING THE MATERIAL IN THIS DOCUMENT THAT CONFLICT WITH THESE TERMS, THE WARRANTY TERMS IN THE SEPARATE AGREEMENT SHALL CONTROL. KEYSIGHT TECHNOLOGIES DOES NOT WARRANT THIRD-PARTY SYSTEM-LEVEL (COMBINATION OF CHASSIS, CONTROLLERS, MODULES, ETC.) PERFORMANCE, SAFETY, OR REGULATORY COMPLIANCE, UNLESS SPECIFICALLY STATED.

Technology Licenses

The hardware and/or software described in this document are furnished under a license and may be used or copied only in accordance with the terms of such license.

U.S. Government Rights

The Software is “commercial computer software,” as defined by Federal Acquisition Regulation (“FAR”) 2.101. Pursuant to FAR 12.212 and 27.405-3 and Department of Defense FAR Supplement (“DFARS”) 227.7202, the U.S. government acquires commercial computer software under the same terms by which the software is customarily provided to the public. Accordingly, Keysight provides the Software to U.S. government customers under its standard commercial license, which is embodied in its End User License Agreement (EULA), a copy of which can be found at <http://www.keysight.com/find/sweula>. The license set forth in the EULA represents the exclusive authority by which the U.S. government may use, modify, distribute, or disclose the Software. The EULA and the license set forth therein, does not require or permit, among other things, that Keysight: (1) Furnish technical information related to commercial computer software or commercial computer software documentation that is not customarily provided to the public; or (2) Relinquish

to, or otherwise provide, the government rights in excess of these rights customarily provided to the public to use, modify, reproduce, release, perform, display, or disclose commercial computer software or commercial computer software documentation. No additional government requirements beyond those set forth in the EULA shall apply, except to the extent that those terms, rights, or licenses are explicitly required from all providers of commercial computer software pursuant to the FAR and the DFARS and are set forth specifically in writing elsewhere in the EULA. Keysight shall be under no obligation to update, revise or otherwise modify the Software. With respect to any technical data as defined by FAR 2.101, pursuant to FAR 12.211 and 27.404.2 and DFARS 227.7102, the U.S. government acquires no greater than Limited Rights as defined in FAR 27.401 or DFAR 227.7103-5 (c), as applicable in any technical data.

Safety Notices

CAUTION

A CAUTION notice denotes a hazard. It calls attention to an operating procedure, practice, or the like that, if not correctly performed or adhered to, could result in damage to the product or loss of important data. Do not proceed beyond a CAUTION notice until the indicated conditions are fully understood and met.

WARNING

A WARNING notice denotes a hazard. It calls attention to an operating procedure, practice, or the like that, if not correctly performed or adhered to, could result in personal injury or death. Do not proceed beyond a WARNING notice until the indicated conditions are fully understood and met.

The following safety precautions should be observed before using this product and any associated instrumentation.

This product is intended for use by qualified personnel who recognize

shock hazards and are familiar with the safety precautions required to avoid possible injury. Read and follow all installation, operation, and maintenance information carefully before using the product.

WARNING

If this product is not used as specified, the protection provided by the equipment could be impaired. This product must be used in a normal condition (in which all means for protection are intact) only.

The types of product users are:

- Responsible body is the individual or group responsible for the use and maintenance of equipment, for ensuring that the equipment is operated within its specifications and operating limits, and for ensuring operators are adequately trained.
- Operators use the product for its intended function. They must be trained in electrical safety procedures and proper use of the instrument. They must be protected from electric shock and contact with hazardous live circuits.
- Maintenance personnel perform routine procedures on the product to keep it operating properly (for example, setting the line voltage or replacing consumable materials). Maintenance procedures are described in the user documentation. The procedures explicitly state if the operator may perform them. Otherwise, they should be performed only by service personnel.
- Service personnel are trained to work on live circuits, perform safe installations, and repair products. Only properly trained service personnel may perform installation and service procedures.

WARNING

Operator is responsible to maintain safe operating conditions. To ensure safe operating conditions, modules should not be operated beyond the full temperature range specified in the Environmental and physical specification. Exceeding safe operating conditions can result in shorter lifespans, improper module

performance and user safety issues. When the modules are in use and operation within the specified full temperature range is not maintained, module surface temperatures may exceed safe handling conditions which can cause discomfort or burns if touched. In the event of a module exceeding the full temperature range, always allow the module to cool before touching or removing modules from chassis.

Keysight products are designed for use with electrical signals that are rated Measurement Category I and Measurement Category II, as described in the International Electrotechnical Commission (IEC) Standard IEC 60664. Most measurement, control, and data I/O signals are Measurement Category I and must not be directly connected to mains voltage or to voltage sources with high transient over-voltages. Measurement Category II connections require protection for high transient over-voltages often associated with local AC mains connections. Assume all measurement, control, and data I/O connections are for connection to Category I sources unless otherwise marked or described in the user documentation.

Exercise extreme caution when a shock hazard is present. Lethal voltage may be present on cable connector jacks or test fixtures. The American National Standards Institute (ANSI) states that a shock hazard exists when voltage levels greater than 30V RMS, 42.4V peak, or 60VDC are present. A good safety practice is to expect that hazardous voltage is present in any unknown circuit before measuring.

Operators of this product must be protected from electric shock at all times. The responsible body must ensure that operators are prevented access and/or insulated from every connection point. In some cases, connections must be exposed to potential human contact. Product operators in these circumstances must be trained to protect themselves from the risk of electric shock. If the circuit is capable of operating at or above 1000V,

no conductive part of the circuit may be exposed.

Do not connect switching cards directly to unlimited power circuits. They are intended to be used with impedance-limited sources. NEVER connect switching cards directly to AC mains. When connecting sources to switching cards, install protective devices to limit fault current and voltage to the card.

Before operating an instrument, ensure that the line cord is connected to a properly-grounded power receptacle. Inspect the connecting cables, test leads, and jumpers for possible wear, cracks, or breaks before each use.

When installing equipment where access to the main power cord is restricted, such as rack mounting, a separate main input power disconnect device must be provided in close proximity to the equipment and within easy reach of the operator.

For maximum safety, do not touch the product, test cables, or any other instruments while power is applied to the circuit under test. ALWAYS remove power from the entire test system and discharge any capacitors before: connecting or disconnecting cables or jumpers, installing or removing switching cards, or making internal changes, such as installing or removing jumpers.

Do not touch any object that could provide a current path to the common side of the circuit under test or power line (earth) ground. Always make measurements with dry hands while standing on a dry, insulated surface capable of withstanding the voltage being measured.

The instrument and accessories must be used in accordance with its specifications and operating instructions, or the safety of the equipment may be impaired.

Do not exceed the maximum signal levels of the instruments and accessories, as defined in the specifications and operating information, and as shown on the instrument or test fixture panels, or switching card.

When fuses are used in a product, replace with the same type and rating for continued protection against fire hazard.

Chassis connections must only be used as shield connections for measuring circuits, NOT as safety earth ground connections.

If you are using a test fixture, keep the lid closed while power is applied to the device under test. Safe operation requires the use of a lid interlock.

Instrumentation and accessories shall not be connected to humans.

Before performing any maintenance, disconnect the line cord and all test cables.

To maintain protection from electric shock and fire, replacement components in mains circuits – including the power transformer, test leads, and input jacks – must be purchased from Keysight. Standard fuses with applicable national safety approvals may be used if the rating and type are the same. Other components that are not safety-related may be purchased from other suppliers as long as they are equivalent to the original component (note that selected parts should be purchased only through Keysight to maintain accuracy and functionality of the product). If you are unsure about the applicability of a replacement component, call an Keysight office for information.

WARNING

No operator serviceable parts inside. Refer servicing to qualified personnel. To prevent electrical shock do not remove covers. For continued protection against fire hazard, replace fuse with same type and rating.

PRODUCT MARKINGS:



The CE mark is a registered trademark of the European Community.



Australian Communication and Media Authority mark to indicate regulatory compliance as a registered supplier.



This symbol indicates product compliance with the Canadian Interference-Causing Equipment Standard (ICES-001). It also identifies the product is an Industrial Scientific and Medical Group 1 Class A product (CISPR 11, Clause 4).



South Korean Class A EMC Declaration. This equipment is Class A suitable for professional use and is for use in electromagnetic environments outside of the home. A 급 기기 (업무용 방송통신기자재) 이 기기는 업무용 (A 급) 전자파적합기기로서 판매자 또는 사용자는 이 점을 주의하시기 바라며, 가정외의 지역에서 사용하는 것을 목적으로 합니다.



This product complies with the WEEE Directive marketing requirement. The affixed product label (above) indicates that you must not discard this electrical/electronic product in domestic household waste. **Product Category:** With reference to the equipment types in the WEEE directive Annex 1, this product is classified as “Monitoring and Control instrumentation” product. Do not dispose in domestic household waste. To return unwanted products, contact your local Keysight office, or for more information see <http://about.keysight.com/en/companyinfo/environment/takeback.shtml>.



This symbol indicates the instrument is sensitive to electrostatic discharge (ESD). ESD can damage the highly sensitive components in your instrument. ESD damage is most likely to occur as the module is being installed or when cables are connected or disconnected. Protect the circuits from ESD damage by wearing a grounding strap that provides a high resistance path to ground. Alternatively, ground yourself to discharge any built-up static charge by touching the outer shell of any grounded instrument chassis before touching the port connectors.



This symbol on an instrument means caution, risk of danger. You should refer to the operating instructions located in the user documentation in all cases where the symbol is marked on the instrument.



This symbol indicates the time period during which no hazardous or toxic substance elements are expected to leak or deteriorate during normal use. Forty years is the expected useful life of the product.

CLEANING PRECAUTIONS:

WARNING

To prevent electrical shock, disconnect the Keysight Technologies instrument from mains before cleaning. Use a dry cloth or one slightly dampened with water to clean the external case parts. Do not attempt to clean internally. To clean the connectors, use alcohol in a well-ventilated area. Allow all residual alcohol moisture to evaporate, and the fumes to dissipate prior to energizing the instrument.

Contents

Documentation Access	8
Introduction	9
Follow the Start up Sequence	11
Related Documentation	13
Step 1 - Unpack and Inspect the Module	16
Electrostatic Discharge	16
Inspect for Damage	16
Return an Instrument for Service	17
Step 2 - Verify Shipment Contents and Model Options	18
M9451A Shipment Contents	18
Items included in your M9451A PXIe Measurement Accelerator Shipment	18
Step 3 - Install the Software	19
Software Requirements	19
Hardware Requirements	19
Chassis Requirements	20
Power up the Controller	21
Software Installation Overview	21
Software Installation Procedure	21
Step 4 - Install the Module	23
Module Installation Process Overview	23
Step 5 - Verify Operation of M9451A Module	26
Start SFP	27
Conduct a Self Test	28
LED Status	29
Step 6 - Installation Complete	31
API Overview	31
IVI Drivers	31
Troubleshooting	32
Instrument Problems	32
Error Messages	32
Computer	32
User Permissions	32
Resetting Permissions for a Restricted User	33

Documentation Access

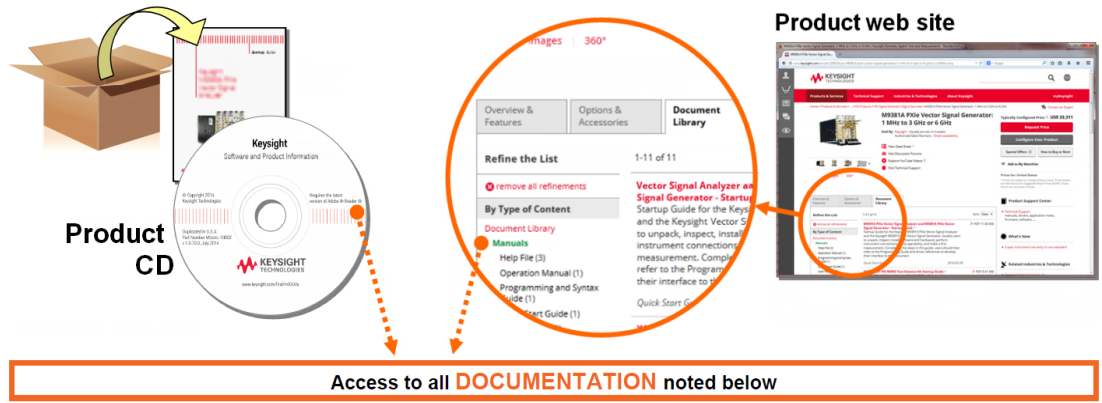

Startup Guide



- Unpack product
- Verify shipment
- Install software
- Verify operation
- Troubleshooting

Data Sheet



- Product description
- Technical specifications

DPD/ET API Help



- Product intro
- Programming Procedures

Soft Front Panel (SFP) user interface

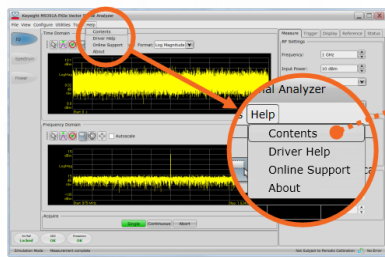

SFP Help System



- Theory of operation
- Block diagram
- Configuration
- Self test
- Operational check
- Field calibration
- Troubleshooting

Visual Studio

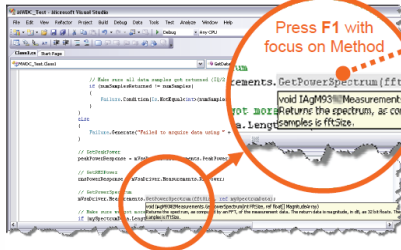

Press F1 with focus on Method

IVI Driver Help System



- IVI-COM and IVI-C driver reference
- Sample programs

DPD/ET Reference Guide



- Block diagram
- Technical specifications
- Sample programs

Introduction

The scope of this Startup Guide is to detail the processes of receiving and installing the Keysight M9451A PXIe Measurement Accelerator. The M9451A PXIe Measurement Accelerator using DPD Option (Digital Pre-Distortion & Envelope Tracking Gateway) shows performance improvements when combining state of the art FPGA's with Keysight's measurement expertise and PXIe's high speed data handling. As part of Keysight's RF PA/FEM Characterization & Test, Reference Solution, this combination provides enhanced performance for envelope tracking and digital pre-distortion measurements required in testing modern power amplifiers (PAs) and front-end modules (FEMs). Hardware acceleration provides speed improvement over Keysight's previous host-based Reference Solution, with closed/open loop digital pre-distortion (DPD) and envelope tracking (ET) measurements.

The key features of Keysight M9451A PXIe Measurement Accelerator are:

- Hardware acceleration provides 10x DPD/ET speed improvement over Keysight's host-based RF PA/FEM Characterization & Test Reference Solution.
- Closed/open loop DPD and ET measurements can be performed in tens of milliseconds thereby reducing overall test time to <100 ms.
- DPD/ET algorithms created in cooperation with leading wireless manufacturers.
- Peer-to-peer connectivity with Keysight M9381A PXIe Vector Signal Generator, M9391A PXIe Vector Signal Analyzer, and M9393A PXIe Performance Vector Signal Analyzer modules.
- Altera Stratix V "A7" FPGA with 4 GB DDR3 memory.

AWG SD H3353

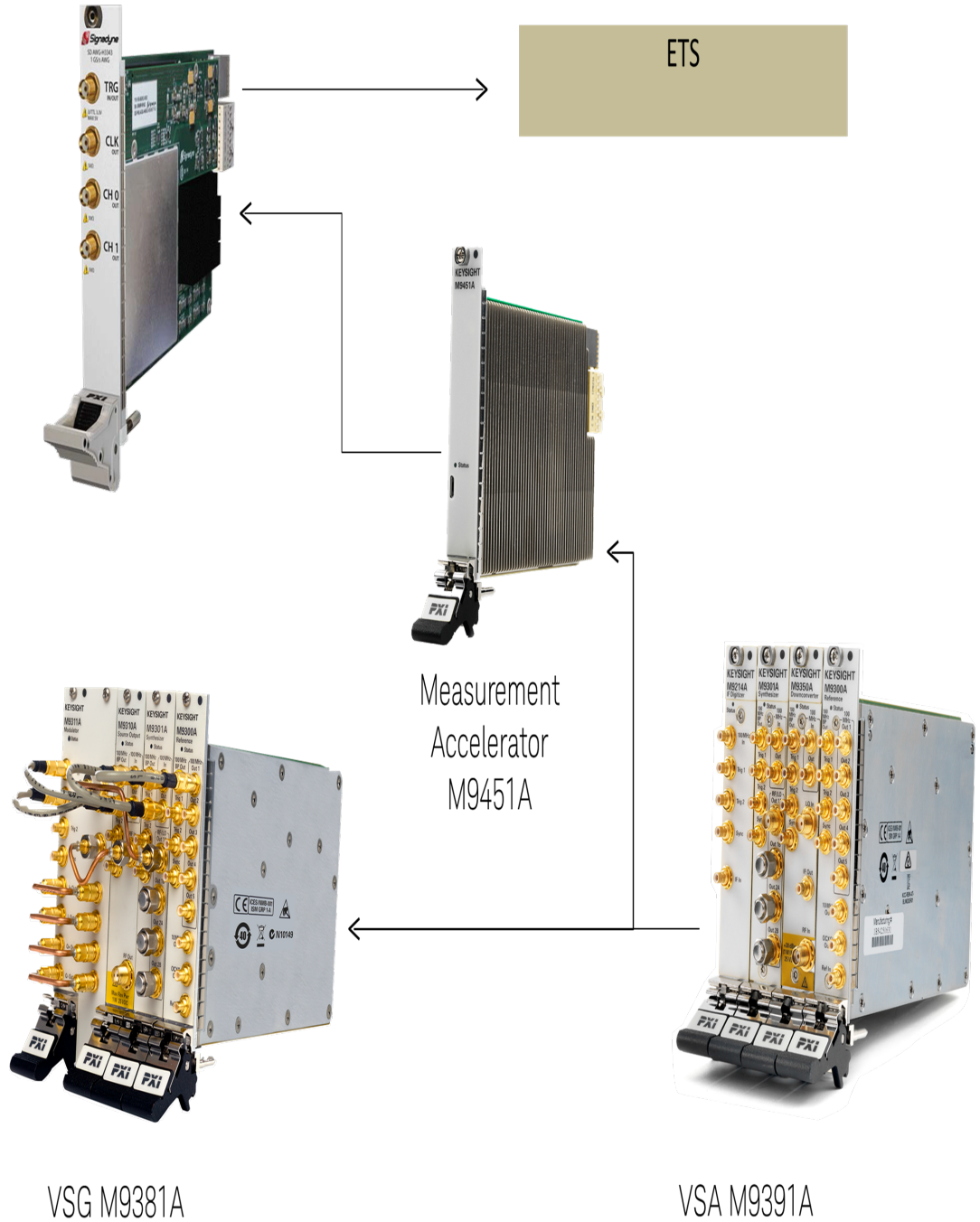

Additionally, installing the required software is documented. If you have any questions after reviewing this information, please contact your local Keysight Technologies Inc. representative or contact us through our website at www.keysight.com/find/m9451a.

NOTE

M9451A module is designed to work with the Keysight's RF PA/FEM Characterization & Test, Reference Solution and allows you to perform fast DPD/ET measurements with hardware that supports peer-to-peer transfers. For more details, refer *M9451A Digital PreDistortion and Envelope Tracking Measurement Accelerator Reference Guide*.

Follow the Start up Sequence

WARNING

Closely follow the start up process flow in this document. Deviating from the sequence can cause unpredictable system behavior, damage your system, and may cause personal injury.

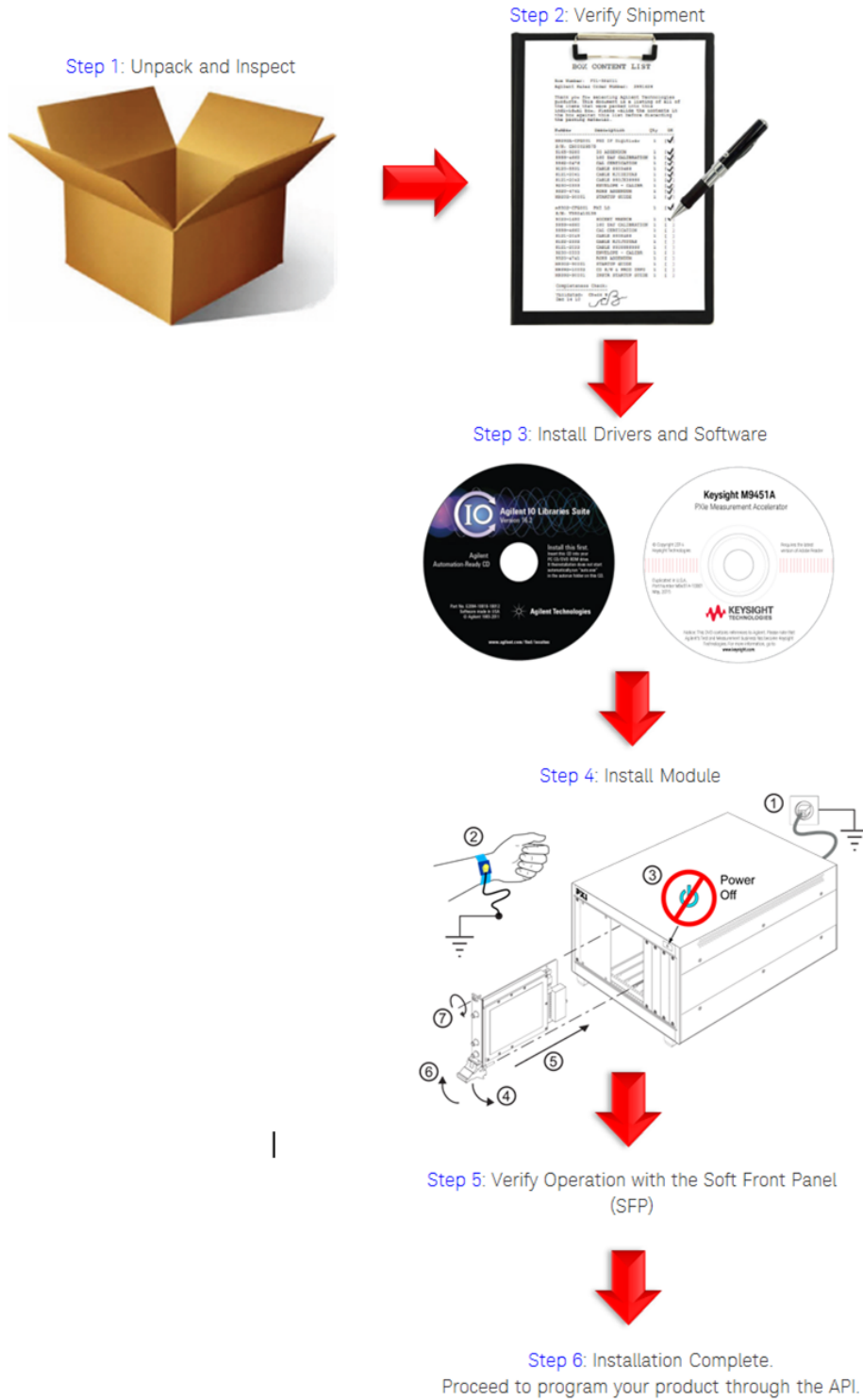

Related Documentation

To access documentation related to the Keysight M9451A PXIe Measurement Accelerator, use one of the following methods:

- If the product software is installed on your PC, the related documents are also available in the software installation directory.

Document	Description	Default Location on 64-bit Windows system	Format
Startup Guide	Includes procedures to help you to unpack, inspect, install (software and hardware), perform instrument connections, verify operability, and troubleshoot your product. Also includes an annotated block diagram.	<YourDrive:>\Program Files (x86)\Keysight\MMAcc\Help\M9451A_StartupGuide.pdf	PDF
.Net API Reference	Shows you how to use Visual Studio 2010 (or later) with the .NET Framework to write IVI-COM Console Applications in Visual C#.	<YourDrive:>\Program Files (x86)\Keysight\MMAcc\Help\M9451A DPD Accelerator API Reference.chm	CHM (Microsoft Help Format)
IVI Driver Reference	Provides detailed documentation of the IVI-COM and IVI-C driver API functions, as well as information to help you get	<YourDrive:>\Program Files (x86)\IVI Foundation\IVI\Drivers\KtMMAcc\KtMMAcc.chm	CHM (Microsoft Help Format)

started with using the IVI drivers in your application development environment.

SFP HelpSystem	Provides detailed documentation of the options and menus available in the Soft Front Panel.	<Your Drive:>\Program Files (x86)\Keysight\MMAcc\Help\M9451_SFP_Help.chm	CHM (Microsoft Help Format)
DPD/ET Measurement Accelerator Reference Guide	Includes concepts and processes to help you in conducting measurements using the DPD/ET option of Keysight M9451A PXIe Measurement Accelerator.	<YourDrive:>\Program Files (x86)\Keysight\MMAcc\Help\DigitalPreDistortionAndEnvelopeTracking_Guide.pdf	PDF

NOTE

Alternatively, you can find these documents under: **Start > All Programs > Keysight > MMAcc.**

- The documentation listed above is also available on the product CD.
- To understand the available user documentation in context to your workflow, [Documentation Access \(page 8\)](#).
- To find the very latest versions of the user documentation, go to the product web site (www.keysight.com/find/m9451a) and download the files from the Manuals support page (go to **Document Library > Manuals**):

Overview & Features	Options & Accessories	Document Library
---------------------	-----------------------	-------------------------

Refine the List

By Type of Content
Manuals (5) ←

Step 1 - Unpack and Inspect the Module

CAUTION

The module is shipped in materials which prevent damage from static. The module should only be removed from the packaging in an anti-static area ensuring that correct anti-static precautions are taken. Store the module in an anti-static envelope when not in use.

Electrostatic Discharge

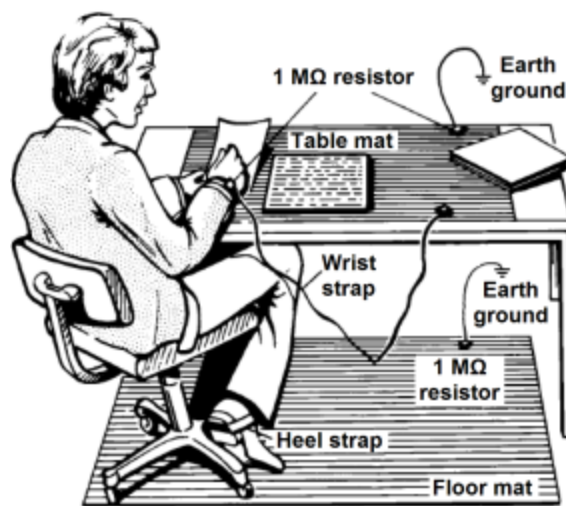

Electrostatic discharge (ESD) can damage or destroy electronic components. Use a static-safe work station to perform all work on electronic assemblies. The figure (left) shows a static-safe work station using two types of ESD protection: conductive table-mat and wrist-strap combination, and conductive floor-mat and heel-strap combination. Both types, when used together, provide a significant level of ESD protection. Of the two, only the table-mat and wrist-strap combination provides adequate ESD protection when used alone. To ensure user safety, the static-safe accessories must provide at least 1 MΩ of isolation from ground.

WARNING

DO NOT use these techniques for a static-safe work station when working on circuitry with a voltage potential greater than 500 volts.

Inspect for Damage

After unpacking an instrument, inspect it for any shipping damage. Report any damage to the shipping agent immediately, as such damage is not covered by the warranty (see warranty information at beginning of this document).

CAUTION

To avoid damage when handling a module, do not touch exposed connector pins.

NOTE

See www.keysight.com/find/tips for information on preventing damage to your keysight equipment.

Return an Instrument for Service

Should it become necessary to return an instrument for repair or service, follow the steps below:

1. Review the warranty information shipped with your product.
2. Contact Keysight to obtain a Return Material Authorization (RMA) and return address. For assistance finding Keysight contact information, go to www.keysight.com/find/assist.
3. Write the following information on a tag and attach it to the malfunctioning equipment:
 - Name and address of owner. A P.O. box is not acceptable as a return address.
 - Module serial number(s). The serial number label is located on the side panel of the module. The serial number can also be read from the Soft Front Panel interface - after the hardware is installed.
 - Description of failure or service required.
4. Pack the instrument in its original packaging. Include all cables. If the original packaging material is not available, use anti-static bubble wrap or packing peanuts and place the instrument in a sealed container and mark the container -FRAGILE-.
5. On the shipping label, write ATTENTION REPAIR DEPARTMENT and the RMA number.

NOTE

In your correspondence, refer to the module by serial number and the instrument by model number.

Step 2 - Verify Shipment Contents and Model Options

M9451A Shipment Contents

Keysight M9451A PXIe Measurement Accelerator is a closed measurement acceleration engine for the Power Amplifier Reference Solution housed in a PXIe chassis. It allows you to perform hardware accelerated measurements with hardware that supports peer-to-peer transfers (M9381A and M9391A modules). This module delivers this functionality through propriety APIs and does not allow the customer to reprogram the FPGA with a custom image.

Items included in your M9451A PXIe Measurement Accelerator Shipment

Qty	Keysight Part Number	Description
1	M9451A	Keysight M9451A PXIe Measurement Accelerator
2	M9451-10001	Software and Product Information CD, contains: Soft Front Panel installers, drivers, and all printed documentation in PDF format (also available at www.keysight.com/find/m9451a-driver)
3	M9451-90001	Keysight M9451A PXIe Measurement Accelerator Startup Guide
4	M9451-90002	Keysight M9451A PXIe Measurement Accelerator Quick Start Flyer

Step 3 - Install the Software

- [Step 3 - Install the Software \(page 19\)](#)
- [Step 3 - Install the Software \(page 19\)](#)
- [Step 3 - Install the Software \(page 19\)](#)

Software Requirements

Following is the Keysight's recommended configuration for M9451A PXIe Measurement Accelerator:

Topic	Windows 7 Requirements
Operating system	Windows 7 (32-bit and 64-bit), WES7
Processor speed	1 GHz 32-bit (x86), 1 GHz 64-bit (x64), no support for Itanium64
Available memory	4 GB minimum (8 GB recommended for 64-bit operating systems)
Available disk space	1.5 GB available hard disk space, includes: <ul style="list-style-type: none"> - 1 GB available for Microsoft .NET Framework 3.5 SP1 - 100 MB for Keysight IO Libraries Suite
Video	Support for DirectX 9 graphics with 128 MB graphics memory recommended (Super VGA graphics is supported)
Browser	Microsoft Internet Explorer 7.0 or greater

Hardware Requirements

Following is the Keysight's recommended hardware configuration for M9451A PXIe Measurement Accelerator:

Topic	Requirements
Chassis	M9018 Chassis with PXI-H slots
Controllers	A PXI or PXI Express embedded controller or remote controller (external PC connected to the chassis by a PCI-to-PXI interface) is required.
Embedded controller	Keysight M9036A or M9307A or an embedded controller that meets the following requirements: <ul style="list-style-type: none"> - PXIe system controller (PXI-1 embedded controllers are not compatible) - Utilize a 2x8, or 4x4 PXIe system slot link configuration. - Run one of the operating systems listed in Software Requirements (above).

Topic	Requirements
Remote controller	(for Keysight M9018A chassis use only) A PC running one of the operating systems listed in Software Requirements (above) and a Keysight M9021A Cable Interface x8 with one of the following PC interface options: <ul style="list-style-type: none">– Keysight M9045B PCIe ExpressCard Adaptor x1, with cable (for a laptop PC)– Keysight M9048A PCIe Desktop Adaptor x8, with cable (for desktop PCs)

Chassis Requirements

The following are the recommended best practices to ensure proper and safe module operating conditions:

- Ensure proper chassis air flow is maintained
 - Select a chassis that provides thermal protection if fans become inoperable or forced air cooling is obstructed
 - Use slot blockers (Keysight model Y1212A, 5 per kit) and EMC filler panels in empty module slots to ensure proper operating temperatures. Keysight chassis M9018A chassis and slot blockers optimize module temperature performance and reliability of test.
 - Set chassis fans to high or auto. Do not disable fans.
 - Position chassis to allow plenty of space around chassis air intake and fan exhaust.
 - At environment temperatures above 45°C, set chassis fan speed to high.
- ⊖** It is recommended that the temperature, power and current values do not exceed the maximum values listed in the Technical Specifications section of M9451A Data Sheet (which can be found at www.keysight.com/find/m9451a), Otherwise it may damage the module. In case these values come close to any of the listed maximum values, you should either move your instrument to a cooler environment or turn on the chassis fans to cool it.

M9018A Chassis Air Flow

The M9018A has multiple air intakes. They are located at the lower sides, lower front, and bottom of the chassis.



Power up the Controller

CAUTION

If you are using a remote controller and you have installed the interface cable, you must power up the chassis BEFORE you power up the PC. When you power down your chassis, Shut Down the PC BEFORE you power down the chassis.

CAUTION

PXIe hardware does not support "hot-swap" (changing modules while power is applied to the chassis) capabilities. Before installing or removing a module to/from the chassis, power off the chassis to prevent damage to the module.

If you are using an embedded controller, complete the following steps:

1. Install the embedded controller module into the compatible chassis. The Keysight M9037A PXIe Embedded Controller and Keysight M9018A PXIe Chassis are recommended. Please refer to the embedded controller and chassis documentation for further details.
2. Connect peripherals (mouse, keyboard, monitor).
3. Power up the chassis.

Software Installation Overview

This installation includes the following:

- Keysight IO Libraries Suite (IOLS), which includes the Keysight Connection Expert. This software is available at www.keysight.com/find/iosuite . This software must be installed first.

NOTE

Version 16.3.16603.3 (or newer) of the Keysight IO Libraries Suite is required.

- Instrument software, which includes the soft front panel (SFP), device drivers (IVI-C and IVI-COM) and documentation for Keysight M9451A PXIe Measurement Accelerator. This software is included with your shipment and is also available at www.keysight.com/find/m9451a-driver .

Software Installation Procedure

The following are steps to install the M9451A software:

1. Launch the installer file to run the setup.
Click **Next**.
2. Check the the Keysight Software End User License Agreement and select I accept the terms of the license agreement option.
Click **Next**.
After you accept the terms of license agreement, the Installation wizard prompts you to choose either a complete or custom setup to install.
3. Choose the features to install and click **Next**.
4. Follow the guided tour to complete the installation.
Click **Next**.
5. After the installation completes, do one of the following:
 - For Embedded Controller:
 - i. Select **Yes**, I want to restart my computer now. This is the default selection.

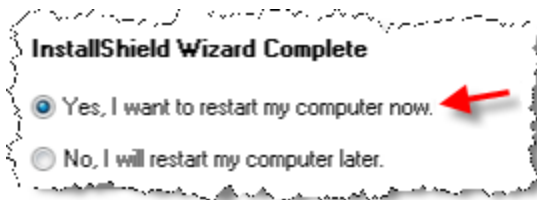

- ii. Click **Finish**.
 - iii. Wait for the system to restart.
- For Remote Controller:
(Follow these steps in order, or else instrument damage may result.)
 - i. Select **No**, I will restart my computer later.



- ii. Click **Finish**.
 - iii. Shut down the remote controller PC. Use **Start > Shut down**.
 - iv. Power down the chassis.
 - v. Power up the chassis.
 - vi. Power up the remote controller PC.

Step 4 - Install the Module

CAUTION

PXI hardware does not support "hot-swap" (changing modules while power is applied to the chassis) capabilities. Before installing or removing a module to/from the chassis, power off the chassis to prevent damage to the module.

NOTE

M9451A module is factory tested, aligned and shipped as a standalone module. It can be used in a chassis with PXI-H chassis slots.

Module Installation Process Overview

7 ^H The module can be installed in any hybrid PXI slot marked with a peripheral slot compatibility image (solid black circle with the letter -H- for hybrid).

1. Make sure that the line cord is plugged in to establish earth ground and that the chassis power switch is Off.
2. If the chassis has multiple fan speed settings, ensure that the fan switch is set appropriately for the system. Default setting is AUTO fan speed and the inhibit set to DEF.



3. Position the chassis to provide ample space between the chassis fan intake and exhaust vents. Blockage by walls or obstructions affects the air flow needed for cooling. (Refer to the chassis documentation for more information about cooling).
4. Before inserting a module into the chassis, back the mounting screws out to ensure that there is no interference between the screws and the mounting rails.

NOTE

Keysight M9451A PXIe Measurement Accelerator uses peer-to-peer (module-to-module) data transfer over the PXIe Express chassis backplane. Therefore, install the M9451A module into a chassis that supports peer-to-peer PXI Express data transfer between it and the M9381A or M9391A modules. For best performance when using the Keysight M9018A PXIe 18-Slot Chassis, install the M9381A modules into a x8 slot, which are slots 2, 6, 11, and 15.

5. Holding the module by the injector/ejector handle, slide it into an available PXIe (or hybrid) slot, as shown in the following figure.

- a. Install the module into the slot of the chassis by placing the module card edges into the front module guides (top and bottom).
 - b. Slide the module to the rear of the chassis and ensure that the injector/ejector handle is pushed down in the unlatched (downward) position.
 - c. Slide the module completely into the chassis. When you begin to feel resistance, pull up on the injector/ejector handle to fully inject the module into the chassis.
6. Secure the module to the chassis using the module mounting screws. Use a #1 Pozidriv[®] or a slotted screwdriver and torque to 5 Lb-In (0.57 N-m). Performance may suffer if the screws are not tightened properly.

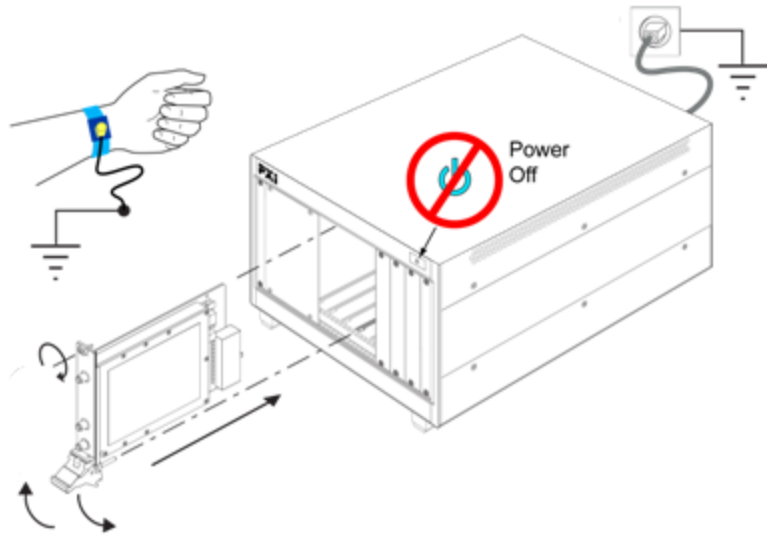

7. Verify that the PXIe chassis fans are operable and free of dust and other contaminants that may restrict airflow.
8. Install filler panels and slot blockers after installing the module. Missing filler panels or slot blockers may disrupt air circulation in the chassis. The left-most slot does not accept a slot blocker.
9. If you are using a PCIe Cable Interface, such as the Keysight M9021, connect the Cable Interface in the chassis to the PC host per the instructions that came with the Cable Interface.
10. Power up the PXIe chassis.
11. If you are using a remote PC, reboot the PC host.
12. Proceed to [Step 5 - Verify Operation of M9451A Module \(page 26\)](#).

Step 5 - Verify Operation of M9451A Module

If you are unable to communicate with Keysight M9451A PXIe Measurement Accelerator, verify that the following installations are correct:

- Keysight IO Libraries Suite
- Keysight M9451A PXIe Measurement Accelerator SFP program
- Keysight Connection Expert
- Module and chassis drivers
- System Interface Card and PC PXIe card connections, if you are using an external host PC

If all the modules and their slot locations are not visible in the Connect to Instrument dialog of SFP program:

1. Close the SFP.
2. Start Keysight Connection Expert by selecting Start > All Programs > Keysight Connection Expert.
3. On the Instruments tab, click the Rescan button.
4. On the PXI/AXIe Chassis tab, verify the module appears in the chassis slot list.
5. Restart the SFP.

The Measurement Accelerator IVI driver software must be installed before the M9451A PXIe Measurement Accelerator appears in the Chassis Content view. If the driver is missing, the module may appear in the Instruments view, but with an unknown slot number.

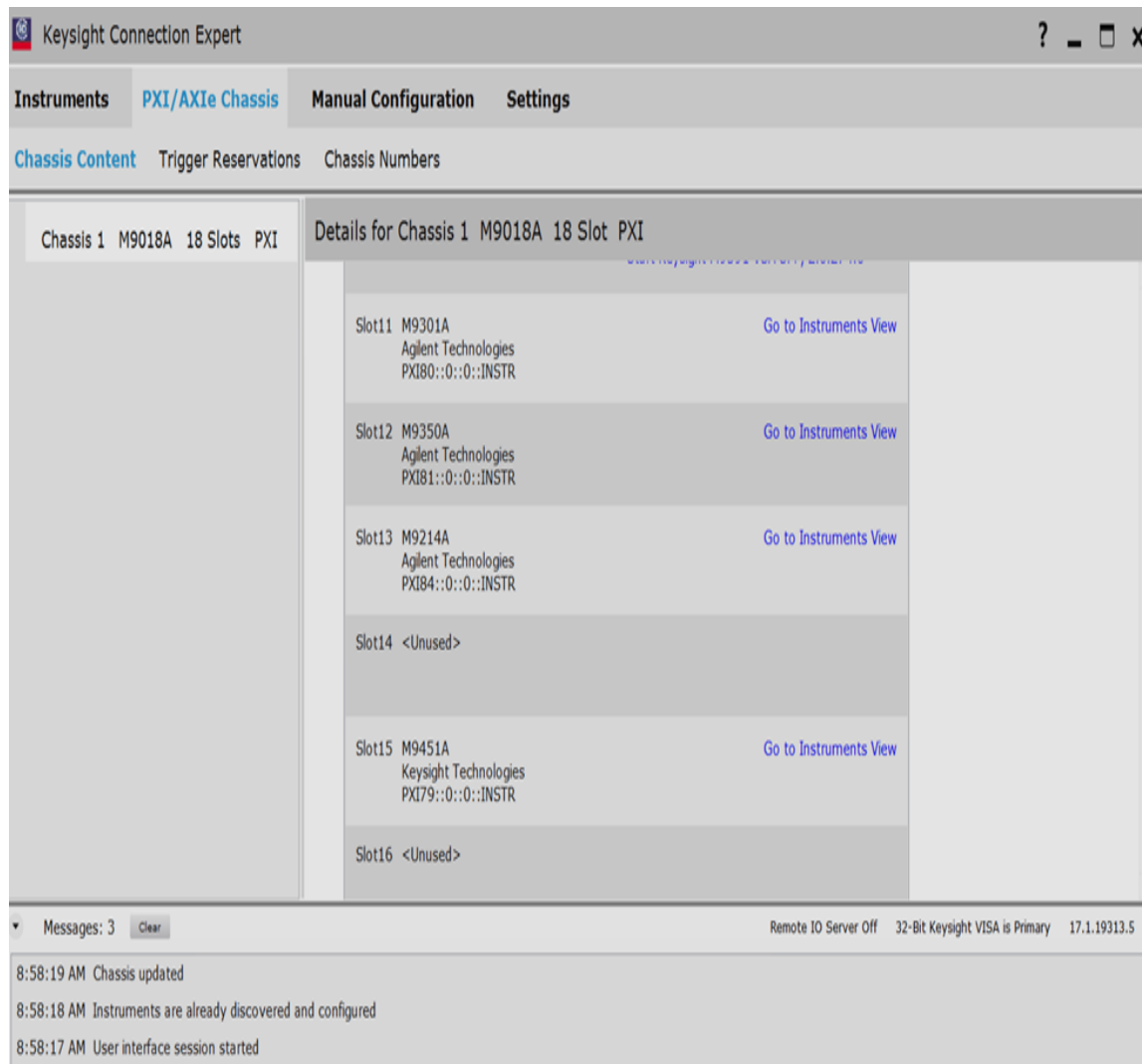

Start SFP

1. Power ON to the Chassis.
2. The first step in this process is to conduct a Self Test of M9451A PXIe Measurement Accelerator.
 - a. Open the M9451A SFP by selecting **Start > All Programs > Keysight > MMAcc > MMAcc SFP**.
 - b. Select the M9451A module in the **Connect to Instrument** dialog and click **Connect** to initialize the instrument .

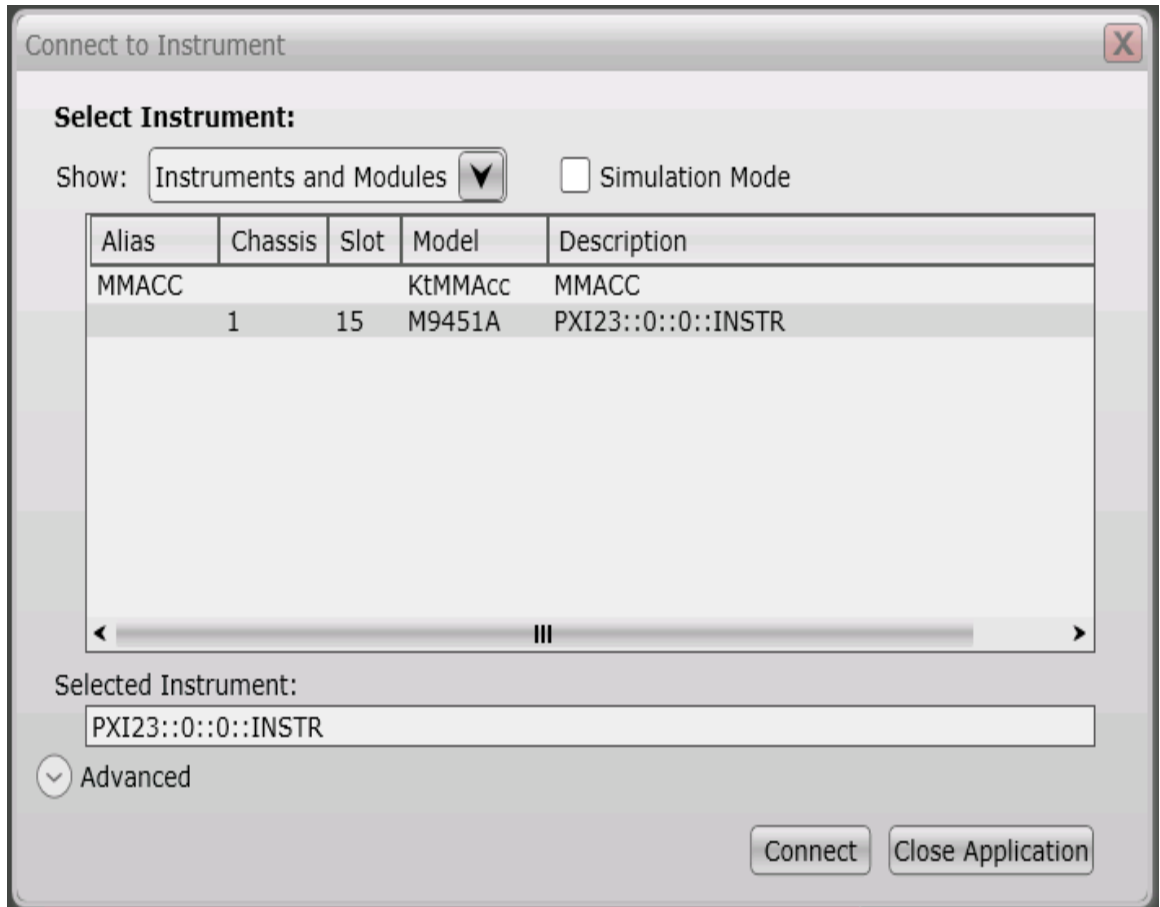

3. Check the front panel Status LED's of the module. It should be solid green after successfully connecting with the SFP.

Conduct a Self Test

Conduct a Self Test on M9451A module (**Utilities** > **Self Test...** > **Run Self Test**).

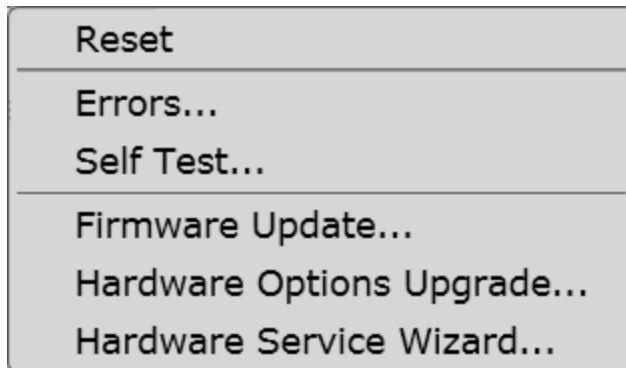

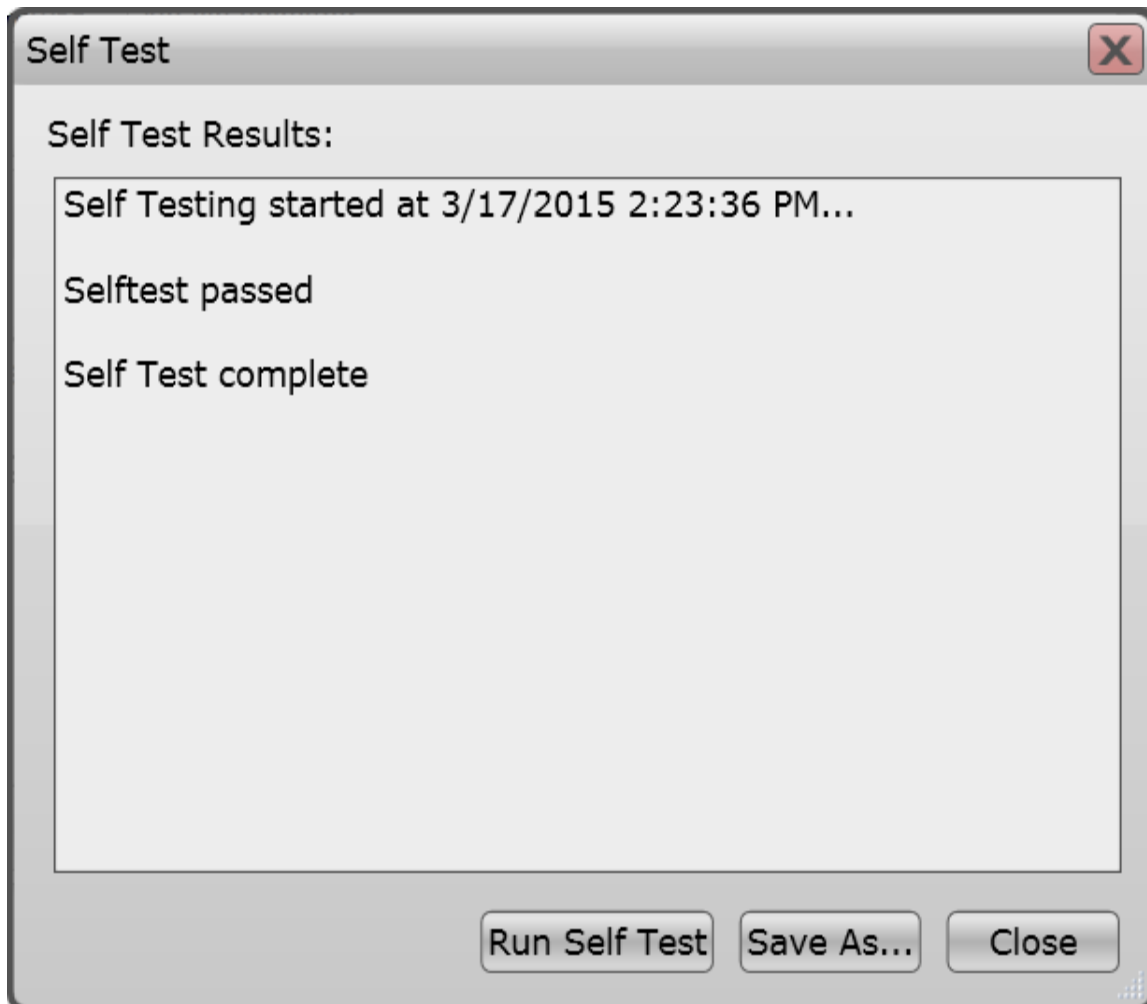

Self Test Failure

If the Self Test does not pass for the instrument, the test indicates the module is likely to need service. In such cases, you should return the module to a [Keysight Technologies Service Center](#).

See [Return an Instrument for Service \(page 17\)](#).

LED Status

When power is first applied to the M9451A PXIe Measurement Accelerator, the LED starts in the OFF state and then changes to green after a few moments when PXI enumeration has taken place. Generally, when the LED status is solid green or solid blue, it means that the module is working correctly. The following table lists the states (colors) of the LED status:

Status LED color	Description
------------------	-------------

LEDStatus

Off	Not connected to power supply. Or, a failure could have possibly occurred in the chassis or module.
Blue – solid	Power ON. No active driver software session.
Green – solid	Driver session successfully initialized. Connection to SFP is successful.
Green – blinking	The accelerator is processing data, or a self-test is running.
Yellow – solid	An error or self-test failure occurred.
Red – solid	Error condition. Analog power supply shut down due to over-temperature or excessive current draw.

Step 6 - Installation Complete

Proceed to program your product by means of the applications programming interface (API) for the supplied drivers.

API Overview

IVI Drivers

Keysight's IVI drivers simplify the creation and maintenance of instrument control applications in a variety of development environments; they allow programmatic control of instrumentation while providing a greater degree of instrument interchangeability and code reuse. IVI drivers currently come in two basic types: IVI-COM and IVI-C. Although the functionality offered by both types of drivers is often very similar, the fundamental differences in interface technology results in a very different end-user experience. The IVI drivers support compiling application programs for 32- or 64-bit platforms.

Supported ADEs (application development environments) Arguably the most important consideration in comparing IVI-COM and IVI-C drivers is the end user experience in various ADEs. Since IVI-COM drivers are based on Microsoft COM technology, it's not surprising that IVI-COM drivers offer the richest user experience in Microsoft ADEs. Users working in Visual C++, Visual C#, Visual Basic.NET, and Visual Basic 6 enjoy a host of features, such as object browsers, IntelliSense, and context-sensitive help.

When you install the product software, the IVI driver files are installed in the standard IVI Foundation directories (for example, <Your Drive:>\Program Files (x86)\IVI Foundation\IVI\Drivers). Example programs are provided to demonstrate most driver functionality (for example, <Your Drive:>\Program Files (x86)\IVI Foundation\IVI\Drivers\KtMMAcc). The reference material for the driver functions (a Microsoft HTML Help .chm file) is installed with the IVI driver and is available for Microsoft Visual Studio's IntelliSense context linking. In addition, you can directly access the .chm file (KtMMAcc.chm) from this Start menu location: **Start > All Programs > Keysight > MMAcc.**

Troubleshooting

[Instrument Problems \(page 32\)](#) - Provides solutions for measurement or operation problems with the instrument.

[User Permissions \(page 32\)](#) - Describes how to set user permissions for installing and running the software.

Instrument Problems

Error Messages

1. Check the soft front panel for error messages; if possible, correct the conditions indicated by the messages.
When a setting conflict (error) occurs, an error number and a brief message appear in the Errors window. To view the full text of the error messages use the method shown for your instrument:
Press **Utilities** > **Errors** on the soft front panel to view error messages on the display.
2. Refer to the instrument's documentation for further troubleshooting information.
3. Contact a [Keysight Technologies Service Center](#).

Computer

1. Verify that the equipment meets the minimum requirements. Refer [Step 3 - Install the Software \(page 19\)](#).
2. Refer to the computer's documentation for troubleshooting and repair.

User Permissions

To install and run the M9451A software in a Windows operating environment, appropriate security permission settings are required. If you are not logged onto your PC with the required security permissions, the software displays an error message during installation and when attempting instrument connection. The following list identifies the security levels required to install and run the software.

Software Usage	Security Permissions Required
Install the software	Administrator (Administrator Group)
Run the software	Administrator (Administrator Group) or Standard User (Power User Group). Restricted User (User Group) requires an administrator to User Permissions

	(page 32).
Develop application with API	Administrator (Administrator Group), Standard User (Power User Group)
Run application with API	Administrator (Administrator Group), Standard User (Power User Group). Restricted User (User Group) requires an administrator to User Permissions (page 32) .

Resetting Permissions for a Restricted User

A user with Administrator status can reset the permissions of a Restricted User to enable that user to run the software.

The following steps outline the procedure:

1. In Windows Explorer, navigate to the **MMAcc** installation folder. The default directory is:
<Your Drive:>\Program Files (x86)\Keysight\MMAcc.
2. Right click the **MMAcc** installation folder and select **Properties** from the popup menu.
3. Select the **Security** tab and select the user for whom you wish to change permissions in the **Group** or **user names** list.
4. In the **Permissions for Everyone** section, check **Modify** and **Write** in the **Allow** column.
5. Click **Apply** > **OK**.



This information is subject to change
without notice.
© Keysight Technologies 2015
Edition 1, August, 2015
Printed In Malaysia



M9451-90001
www.keysight.com