

Installation Note

HP 8560 E-Series EEROM Upgrade Kit 5063-0669



**HP Part No. 08564-90020 Supersedes: 5962-5015
Printed in USA September 1996**

Notice.

The information contained in this document is subject to change without notice.

Hewlett-Packard makes no warranty of any kind with regard to this material, including but not limited to, the implied warranties of merchantability and fitness for a particular purpose. Hewlett-Packard shall not be liable for errors contained herein or for incidental or consequential damages in connection with the furnishing, performance, or use of this material.

© Copyright 1996 Hewlett-Packard Company.

All Rights Reserved. Reproduction, adaptation, or translation without prior written permission is prohibited, except as allowed under the copyright laws.

1400 Fountaingrove Parkway, Santa Rosa, CA 95403-1799, USA

HP 8560 E-Series EEROM Upgrade Kit 5063-0669

INSTRUMENTS AFFECTED:	HP 8560E spectrum analyzers HP 8561E spectrum analyzers HP 8563E spectrum analyzers
SERIAL NUMBERS:	HP 8560E – 3310Axxxxx/3416Axxxxx HP 8561E – 3310Axxxxx/3416Axxxxx HP 8563E – 3310Axxxxx/3416Axxxxx
TO BE PERFORMED BY:	Customer or HP-qualified personnel

What You'll Find in This Installation Note

This installation note describes how to upgrade the EEROM in an HP 8560 E-Series spectrum analyzer to the larger 8 Kbyte x 8 size. Serial prefixes $\geq 3310A$ and $< 3416A$ require the EEROM upgrade be installed if the firmware is upgraded to a revision later than 930809.

Safety Considerations

Warning	Before you disassemble the instrument, turn the power switch OFF and unplug the spectrum analyzer. Failure to unplug the spectrum analyzer can result in personal injury.
----------------	--

Caution	Electrostatic discharge (ESD) can damage or destroy electronic components. All work on electronic assemblies should be performed at a static-safe work station. Refer to the appropriate spectrum analyzer calibration guide for information about a static-safe work station and ordering static-safe accessories.
----------------	---

Items Shipped with Installation Kit

Table 1-1 lists the parts shipped with the HP 8560 E-Series EEROM Upgrade Kit, HP part number 5063-0669.

Table 1-1. EEROM Upgrade Kit Parts List

Quantity	Description	HP Part Number
1	EEROM, programmed	08564-80037
1	PAL, programmed	08564-80002
1	IC socket, 28 cont	1200-0567
1	Jumper, 1x22	8159-0005
1	Label, .20 x .65	9320-6209
1	Installation note	08564-90020

Required Tools

Table 1-2 lists the tools required to install the new EEROM.

Table 1-2. Required Tools

Description	HP Part Number
4-mm hex (Allen) wrench	8710-1164
T-10 TORX screwdriver	8710-1623
#1 Pozidrive screwdriver	8710-0899

Installation Procedure

1. Remove the spectrum analyzer cover assembly. This is described in procedure 1 of chapter 3 in this installation note.
2. Fold down the A2 Controller Board Assembly. See procedure 2 of chapter 3 in this installation note.
3. Locate the EEROM A2U501 and the PAL A2U406. The Component Level Information manual for your spectrum analyzer includes component location drawings.
4. Remove the EEROM from its socket.
5. Remove the solder from the pins of the PAL and EEROM's socket. Note the orientation of the notch on the PAL and the socket and remove them.
6. Replace them with the new PAL and EEROM socket included in the kit. The new EEROM socket fits into holes that are slightly offset from those of the old EEROM socket.

Caution To prevent damage to the EEROM, make sure that it is oriented correctly with the socket on the A2 assembly. Match the notch at the end of the EEROM with the notch at the end of its socket. Align each EEROM IC pin with the opening of its pin receptacle on the socket.

7. Install the new EEROM by carefully pushing down on both ends of the IC with equal pressure.
8. There is a jumper near A2U500/501. Clip out the jumper that is labeled W501 and install a new jumper in the two holes labeled W500.
9. Attach the label, included in the kit, to the A2 assembly. It should be placed over the existing printed circuit board assembly part number.

Replacement Procedures

Procedure 1. Spectrum Analyzer Cover

Removal/Replacement

1. Disconnect the line-power cord, remove any adapters from the front-panel connectors, and place the analyzer on its front panel.
2. If an HP 85620A mass memory module is mounted on the rear panel, remove it. Loosen (but do not remove) the four rear-bumper screws, using a 4 mm hex wrench. Pull the cover assembly off towards the rear of the instrument.

Caution When replacing the spectrum analyzer's cover, use caution to avoid damaging any cables.

3. When installing the cover assembly, be sure to locate the cover's air vent holes on the bottom side of the spectrum analyzer. Attach with the four screws loosened in step 2, and tighten the four screws gradually to ensure that the cover is seated in the front-frame gasket groove.
4. Torque each screw to 40 to 50 inch-pounds to ensure proper EMI gasket compression.

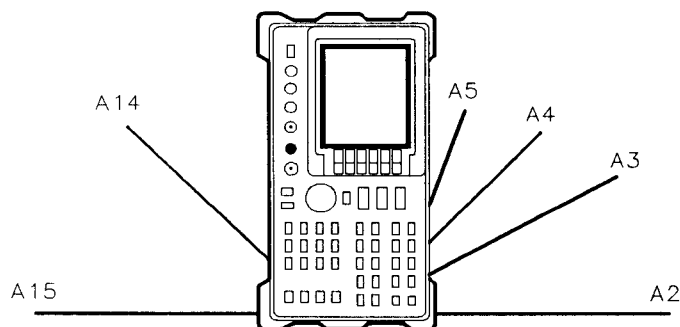

SK122

Figure 3-1. Hinged Assemblies

Procedure 2. A2, A3, A4, and A5 Assemblies

Removal

1. Remove the spectrum analyzer's cover.
2. Place the spectrum analyzer on its right side frame.
3. Remove the eight screws holding the A2, A3, A4, and A5 assemblies to the top of the analyzer. These screws are labeled (2), (3), and (4) in Figure 3-2. They are also labeled on the back of the A2 board assembly.
4. Remove ribbon cable W4 from A2J6. See Figure 3-2.

Caution Do not fold the board assemblies out of the spectrum analyzer one at a time. Always fold the A2 and A3 assemblies as a unit and the A4 and A5 assemblies as a unit. Folding out one assembly at a time binds the hinges attaching the assemblies and may damage an assembly and hinge.

5. The board assemblies are attached to the spectrum analyzer's right side frame with two hinges. Fold both the A2 and A3 assemblies out of the analyzer as a unit.
6. Fold both the A4 and A5 assemblies out of the spectrum analyzer as a unit.
7. Remove the cables from the assembly being removed, as illustrated in Figure 3-3.
8. Remove the two screws that attach the assembly being removed to its two mounting hinges.

Caution Do not torque shield TORX screws to more than 5 inch-pounds. Applying excessive torque will cause the screws to stretch.

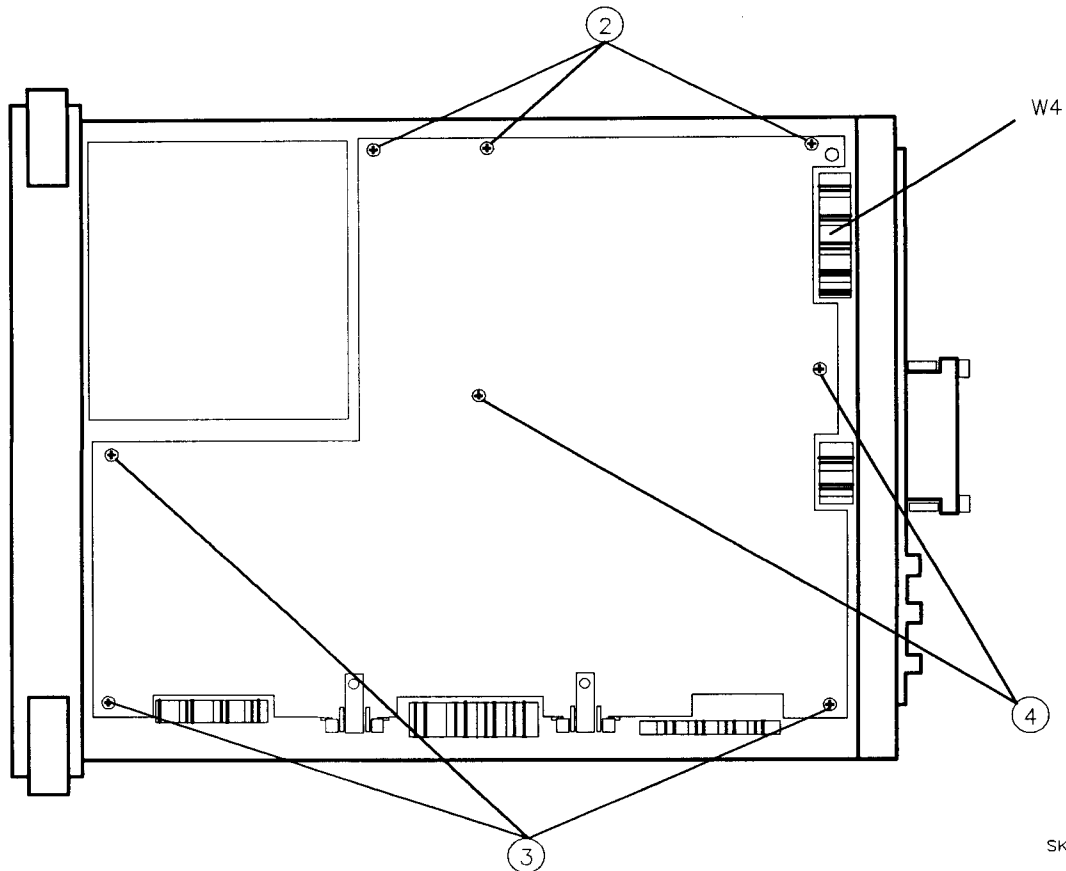

SK 129

Figure 3-2. A2, A3, A4, and A5 Assembly Removal

Replacement

1. Place the spectrum analyzer top-side-up on the work bench.
2. Attach the assembly being installed to the two chassis hinges with two panhead screws.
3. Leave the assembly in the folded-out position and attach ribbon cables W1 and W2.
4. Attach all coaxial cables to the assembly, as illustrated in Figure 3-3.
5. Locate the cable clip on the inside of the right-side frame. Make sure that the coaxial cables are routed properly on the clip as illustrated in Figure 3-5.
6. Lay the A2, A3, A4, and A5 assemblies flat against each other in the folded-out position. Make sure that no cables become pinched between any two assemblies.

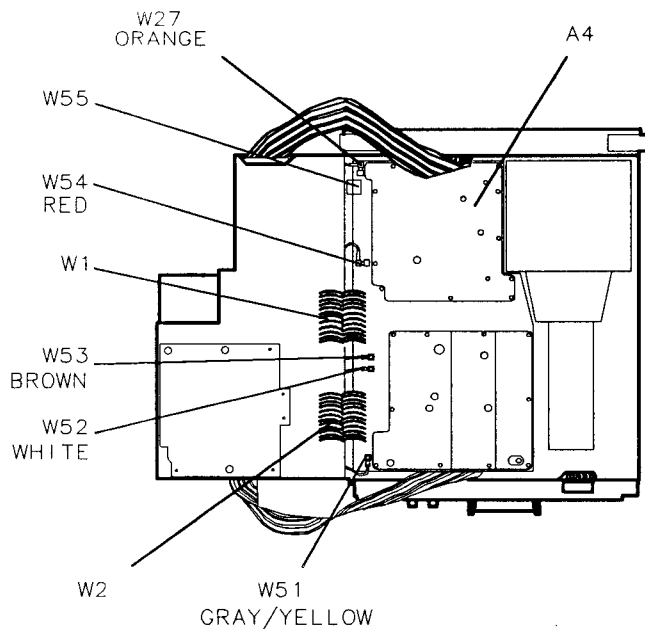
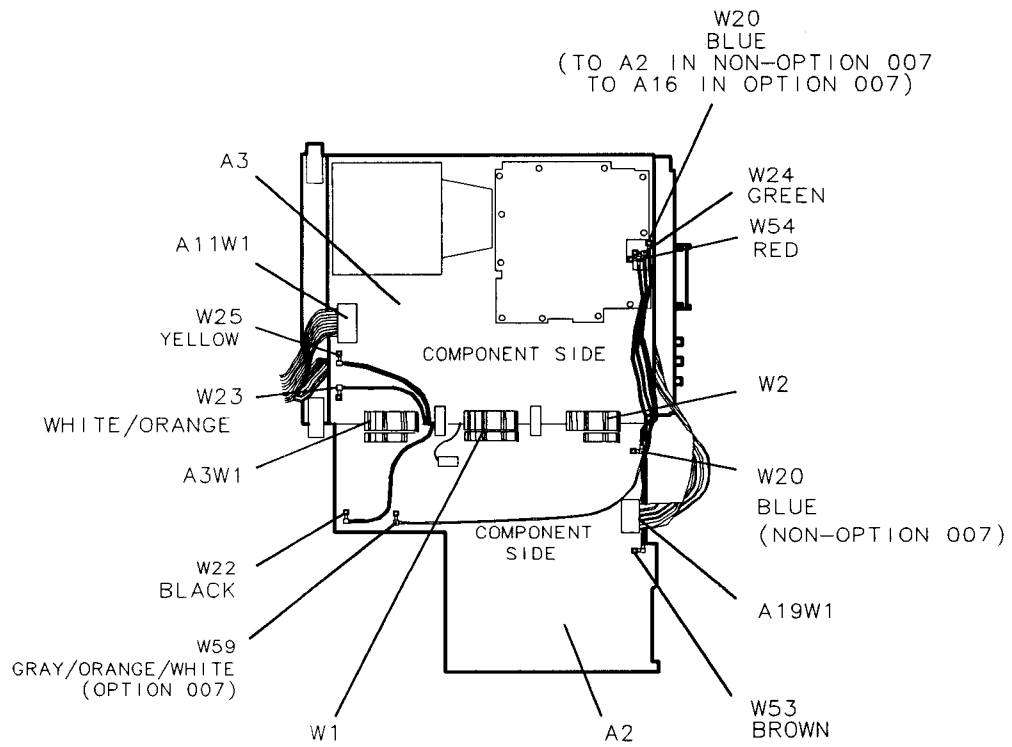

s j12e

Figure 3-3. Assembly Cables (1 of 2)

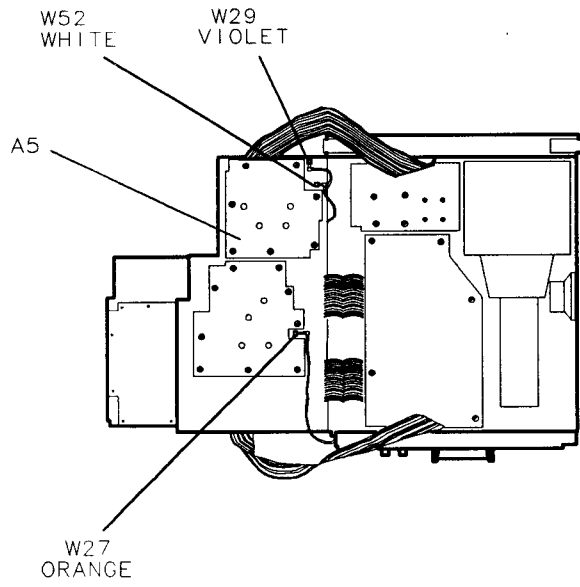

SK131

Figure 3-4. Assembly Cables (2 of 2)

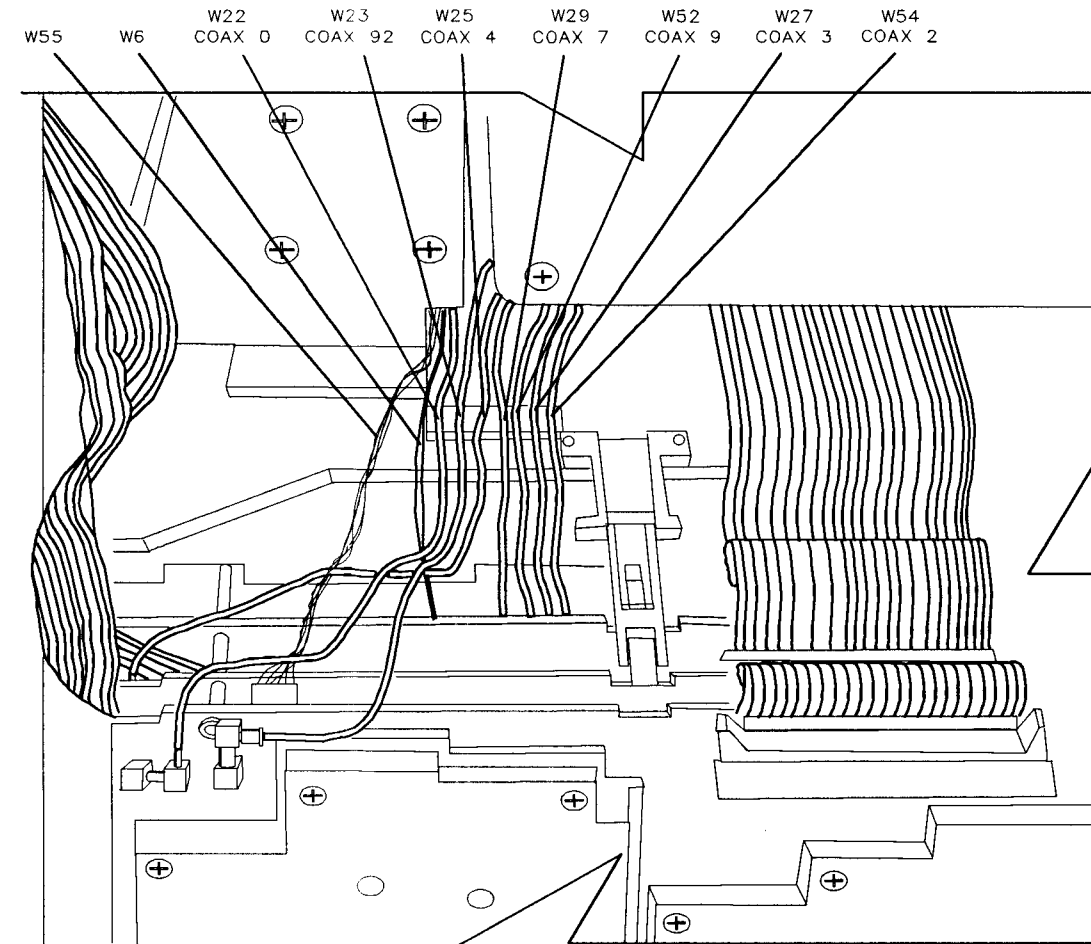

sp142e

Figure 3-5. Coaxial Cable Clip

7. Check to ensure that no cables will become pinched under the hinges when folding up the A4 and A5 assemblies.
8. Fold the A4 and A5 assemblies together as a unit into the analyzer. Use caution to avoid damaging any cable assemblies. The standoffs on the A5 assembly must fit into the cups on the A6 power supply top shield.
9. Fold the A2 and A3 assemblies together as a unit into the spectrum analyzer. Be sure to fold HP-IB cable A19W1 between the A3 and A4 assemblies, using the two sets of hook and loop (Velcro) fasteners.
10. Fold ribbon cable A1A1W1 between A3 and A4 assemblies. Take care to dress the protective tubing as close to A3J602 connector as possible, so that the tubing does not fold with the cable. See Figure 3-6.
11. Attach ribbon cable W4 to A2J6 while folding up the assemblies. See Figure 3-2.
12. Secure the assemblies using the eight screws removed in "Removal" step 3.

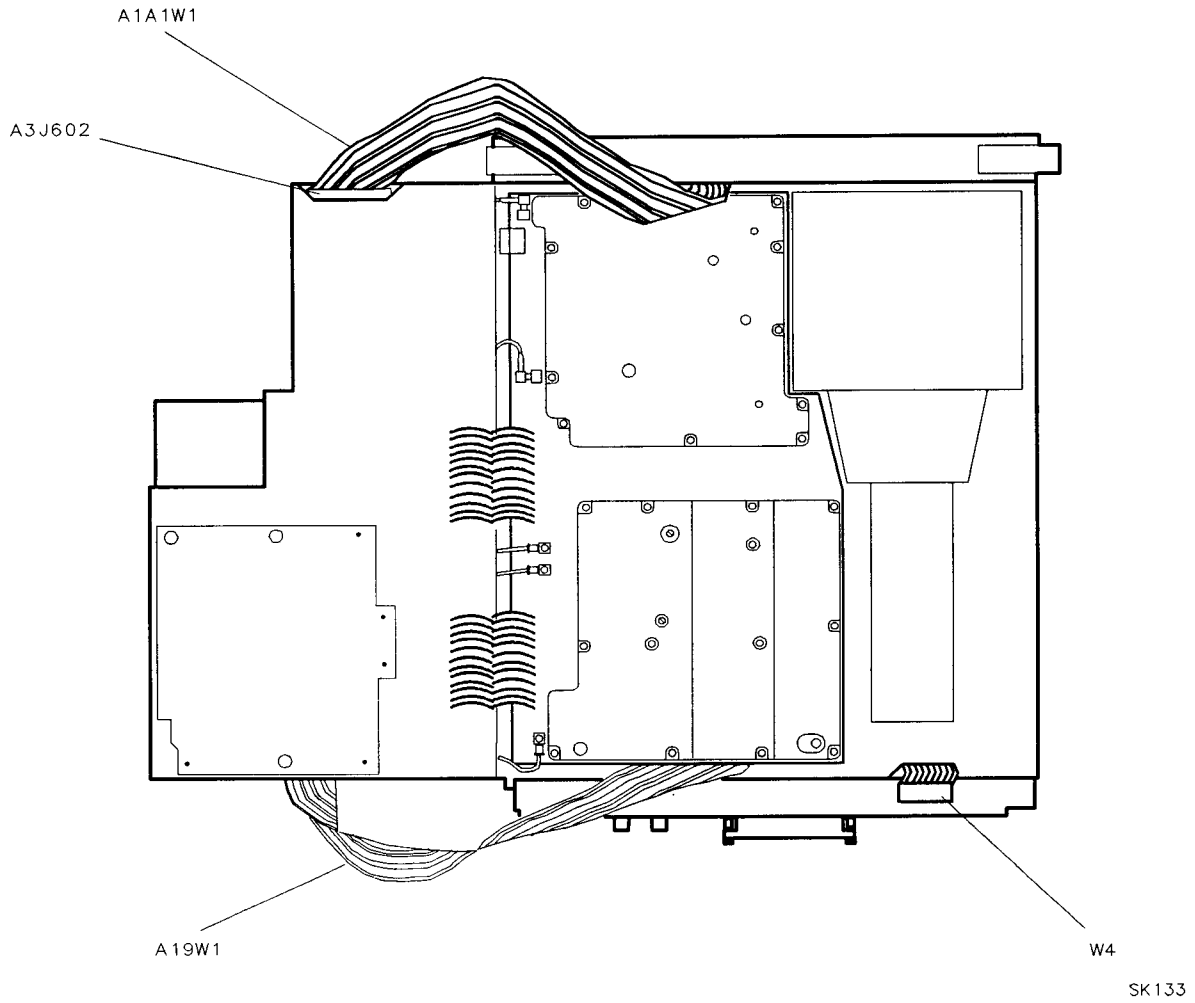

Figure 3-6. HP-IB and A1A1 W1 Cable Placement

**** For HP Internal Reference Only ****

Customer Order Number

Manufacturing Part Number

08564-90020



Printed in USA

September 1996