

Errata

Title & Document Type: 8558B Spectrum Analyzer Operating & Service Manual

Manual Part Number: 08558-90102

Revision Date: July 1985

HP References in this Manual

This manual may contain references to HP or Hewlett-Packard. Please note that Hewlett-Packard's former test and measurement, semiconductor products and chemical analysis businesses are now part of Agilent Technologies. We have made no changes to this manual copy. The HP XXXX referred to in this document is now the Agilent XXXX. For example, model number HP8648A is now model number Agilent 8648A.

About this Manual

We've added this manual to the Agilent website in an effort to help you support your product. This manual provides the best information we could find. It may be incomplete or contain dated information, and the scan quality may not be ideal. If we find a better copy in the future, we will add it to the Agilent website.

Support for Your Product

Agilent no longer sells or supports this product. You will find any other available product information on the Agilent Test & Measurement website:

www.tm.agilent.com

Search for the model number of this product, and the resulting product page will guide you to any available information. Our service centers may be able to perform calibration if no repair parts are needed, but no other support from Agilent is available.



OPERATION AND SERVICE MANUAL

8558B SPECTRUM ANALYZER 0.1 – 1500 MHz

(Includes Option 001 and 002)

SERIAL NUMBERS

This manual applies directly to instruments with serial numbers prefixed 2436A.

With modifications described in Section VII, this manual also applies to instruments with serial number prefixes 1914A through 2332A. For instruments with serial number prefixes lower than 1914A, refer to the HP 8558B Operation and Service Manual dated October 1977, HP Part Number 08558-90043, and the Manual Changes supplement supplied with it.

For additional important information about serial numbers, see INSTRUMENTS COVERED BY MANUAL in Section I.

COPYRIGHT © HEWLETT-PACKARD COMPANY 1973, 1977, 1979, 1981
1212 VALLEY HOUSE DRIVE, ROHNERT PARK, CALIFORNIA, 94928-4999, U.S.A.

MANUAL PART NUMBER: 08558-90102
Microfiche Part Number: 08558-90103

Printed: July 1985

CONTENTS

Section	Page	Section	Page
I	GENERAL INFORMATION		1-1
1-1.	Introduction	3-20.	Signal Input 3-2
1-3.	Description	3-22.	Line Power On 3-2
1-6.	Manual Organization	3-26.	Front-Panel Adjustment Procedure 3-2
1-10.	Specifications	3-28.	Display Adjustments—HP 853A Spectrum Analyzer Display 3-3
1-12.	Safety Considerations	3-29.	Display Adjustments—HP 180-Series Display Mainframe 3-3
1-14.	Instruments Covered by Manual	3-30.	Frequency and Amplitude Adjustments 3-4
1-15.	Serial Numbers		
1-17.	Manual Updating Supplement	IV	PERFORMANCE TESTS 4-1
1-20.	Manual Backdating Changes	4-1.	Introduction 4-1
1-23.	Options	4-3.	Instruments Tested 4-1
1-24.	Option 001	4-5.	Equipment Required 4-1
1-26.	Option 002	4-7.	Test Record 4-1
1-28.	Option 910	4-9.	Calibration Cycle 4-1
1-30.	Accessories Supplied	4-11.	Frequency Span Accuracy 4-2
1-36.	Equipment Required But Not Supplied	4-12.	Tuning Accuracy 4-7
1-37.	Display Mainframe	4-13.	Residual FM 4-10
1-40.	Extender Cable Assembly	4-14.	Noise Sidebands 4-13
1-42.	Measurement Accessories	4-15.	Resolution Bandwidth Accuracy 4-15
1-43.	AC Probe	4-16.	Resolution Bandwidth Selectivity 4-20
1-45.	Modification Kit (Option 807 Connections)	4-17.	Average Noise Level 4-25
1-47.	Oscilloscope Camera	4-18.	Spurious Responses 4-27
1-49.	Service Accessories	4-19.	Residual Responses 4-34
1-51.	Recommended Test Equipment	4-20.	Frequency Response 4-37
		4-21.	Bandwidth Switching (Amplitude Variation) 4-41
II	INSTALLATION AND OPERATION	4-22.	Input Attenuator Accuracy 4-43
	VERIFICATION	4-23.	Reference Level Accuracy 4-46
2-1.	Introduction	4-24.	Display Fidelity 4-51
2-3.	Initial Inspection	4-25.	Calibrator Accuracy 4-55
2-5.	Preparation for Use		
2-6.	Installation	V	ADJUSTMENTS 5-1
2-9.	Side Stop Kits	5-1.	Introduction 5-1
2-14.	Graticule Overlays	5-4.	Equipment Required 5-1
2-16.	Mainframe Interconnections	5-7.	Adjustment Tools 5-1
2-18.	Operating Environment	5-9.	Extender Cable Installation 5-1
2-22.	Modifications	5-13.	Related Adjustments 5-2
2-24.	Storage and Shipment	5-15.	Factory-Selected Components 5-2
2-25.	Environment	5-17.	Second Converter LO and Bandpass Adjustments 5-12
2-27.	Packaging	5-18.	Third Converter LO and Cal Output Adjustment 5-15
2-30.	Operation Verification	5-19.	Slope Adjustment 5-18
		5-20.	Second IF Bandpass Amplifier and Bandpass Filter Adjustment 5-21
III	OPERATION	5-21.	Crystal and LC Bandwidth Adjustments 5-23
3-1.	Introduction	5-22.	3-dB Bandwidth Adjustment 5-29
3-4.	Description	5-23.	Step Gain Assembly RF Gain Adjustment 5-33
3-5.	HP 8558B Spectrum Analyzer		
3-8.	HP-IB		
3-10.	Controls, Indicators, and Connectors		
3-11.	Control Grouping		
3-19.	Operating Precautions		

CONTENTS

Section	Page	Section	Page
5-24.	Step Amplifier Gain Adjustments 5-35	7.4.	How to Use this Backdating Information 7-1/7-2
5-25.	+19.5V Adjustment 5-39		
5-26.	Log Amplifier Log and Linear Adjustment 5-40	VIII	SERVICE 8-1
5-27.	Sweep Time Per Division Adjustment . . . 5-45	8-1.	Introduction 8-1
5-28.	Frequency Control and DPM Adjustments 5-48	8-3.	Schematic Symbols, Terminology, and Voltage Levels 8-1
5-29.	1 dB Offset Adjustment 5-51	8-5.	Test Equipment 8-1
VI	REPLACEABLE PARTS 6-1	8-7.	Major Assembly Locations 8-1
6-1.	Introduction 6-1	8-9.	Troubleshooting 8-1
6-3.	Replaceable Parts List 6-1	8-10.	General Information 8-1
6-6.	Ordering Information 6-1	8-12.	Printed Circuit Board Edge Connector Contact Cleaning 8-1
VII	MANUAL BACKDATING CHANGES 7-1/7-2		The HP 8558B Spectrum Analyzer
7-1.	Introduction 7-1/7-2		Theory of Operation 8-9
			Troubleshooting Hints 8-11

TABLE 1-4. RECOMMENDED TEST EQUIPMENT (4 OF 4)

Equipment	Critical Specifications	Recommended Model	Use*
<i>Cable</i>	<i>BNC, 75Ω, 60 cm (24 in)</i>	<i>HP 11652-60013</i>	<i>P, A, T</i>
<i>Cable</i>	<i>BNC, 75Ω, 90 cm (37 in)</i>	<i>HP 11652-60014</i>	<i>P, A, T</i>
<i>Adapter</i>	<i>BNC (m) to BNC (m)</i>	<i>HP 1250-1288</i>	<i>P, A, T</i>
<i>Adapter</i>	<i>Type N (m) to SMA (f)</i>	<i>HP 1250-1250</i>	<i>P, A, T</i>
* P = Performance Test; A = Adjustment; T = Troubleshooting			

TABLE 1-4. RECOMMENDED TEST EQUIPMENT (3 OF 4)

Equipment	Critical Specifications	Recommended Model	Use*
Adapter	BNC Tee	HP 1250-0781	A
Adapter	Type N (m) to Type N (m)	HP 1250-1475	P
Adapter	BNC (m) to BNC (m)	HP 1250-0216	P
Adapter	Type N (f) to BNC (m)	HP 1250-0077	P
Adapter	SMC (m) to SMC (m)	HP 1250-0827	A, T
Adapter	Type N (m) to SMC (m)	HP 1250-1023	A, T
Adapter	BNC (f) to alligator clips	HP 8120-1292	A, T
Adapter	SMC (f) to SMC (f)	HP 1250-1113	A, T
Adapter	Type N (m) to SMA (f)	HP 1250-1250	P, A
Adapter	BNC (f) to SMA (m)	HP 1250-1200	P
Adapter	SMA (f) to SMA (f)	HP 1250-1158	P
Extender Board	6 pin, 12 contacts with 51.1 Ω resistor from pin 1 to pin 5	HP 08505-60109 HP 0757-0394	A, T
<p>NOTE The following equipment is required for Option 001 and Option 002.</p>			
<i>Termination</i>	<i>Impedance: 75Ω</i>	<i>HP 11652-60010</i>	<i>P</i>
<i>Power Sensor</i>	<i>Frequency Range: 10 MHz to 2 GHz</i> <i>Maximum SWR: 1.18, 10 MHz to 2 GHz</i>	<i>HP 8483A</i>	<i>T</i>
<i>Adapter</i>	<i>75Ω BNC (m) to 75Ω BNC Type N (f)</i>	<i>HP 1250-1534</i>	<i>T</i>
<i>Minimum Loss Adapter</i>	<i>75Ω BNC (f) to 50Ω SMA (m)</i> <i>5.72 dB attenuation</i>	<i>HP 08558-60031</i>	<i>P, A, T</i>
<i>Adapter</i>	<i>BNC (f) to SMA (m)</i>	<i>HP 1250-1200</i>	<i>T</i>
<i>Adapter</i>	<i>SMA (f) to SMA (f)</i>	<i>HP 1250-1158</i>	<i>P, T</i>
<i>Adapter</i>	<i>Type N (f) to Type N (f)</i>	<i>HP 1250-0777</i>	<i>A, T</i>
<i>Cable</i>	<i>BNC, 75Ω, 30 cm (12 in)</i>	<i>HP 11652-60012</i>	<i>P, A, T</i>
* P = Performance Test; A = Adjustment; T = Troubleshooting			

TABLE 1-4. RECOMMENDED TEST EQUIPMENT (2 OF 4)

Equipment	Critical Specifications	Recommended Model	Use*
300 MHz LPF	Rejection: >50 dB for signals above 300 MHz	Telonic TPL 300-4AB	P, A, T
Power Splitter	Frequency Range: 100 kHz to 1.5 GHz Input SWR: ≤ 1.15	HP 11667A	P, A
Directional Bridge	Frequency Range: 900 kHz to 30 MHz	HP 8721A	P
10 dB Attenuator (2 required)	Frequency Range: 100 kHz to 1.5 GHz Accuracy: ± 0.5 dB	HP 8491A, Opt. 010	P, A
Step Attenuator	Frequency Range: 20 MHz to 305 MHz Attenuation: 12 dB in 1 dB steps calibrated at 30 MHz by a standards lab Accuracy: ± 0.25 dB	HP 355C, Opt. H80	P, A, T
Step Attenuator	Frequency Range: 20 MHz to 305 MHz Attenuation: 80 dB in 10-dB steps calibrated at 30 MHz and 280 MHz by a standards lab Accuracy: ± 0.01 dB $\pm 0.02/10$ dB step at calibrated frequencies	HP 355D, Opt. H82	P, A, T
Termination	Impedance: 50 Ω	HP 908A/11593A	P, A
Type N Cable	50 Ω coaxial cable with Type N (m) connectors on both ends	HP 11500A	P, A
BNC Cable	50 Ω coaxial cable with BNC (m) connectors on both ends, 20 cm (9 in)	HP 10502A	P, A, T
BNC Cable (2 required)	50 Ω coaxial cable with BNC (m) connectors on both ends, 120 cm (48 in)	HP 10503A	P, A, T
Cable	BNC to banana plug	HP 11001A	P
Cable	SMC (f) to BNC (m)	HP 11592-60001	A, T
Cable	Banana plug to alligator clips	HP 11102A	A
Adapter	Banana plugs to BNC (f)	HP 10111A	P, T
Adapter (3 required)	Type N (m) to BNC (f)	HP 1250-0780	P, A
Adapter	SMC (m) to BNC (m)	HP 1250-0831	P
Adapter	BNC (f) to BNC (f)	HP 1250-0080	P

* P = Performance Test; A = Adjustment; T = Troubleshooting

TABLE 14. RECOMMENDED TEST EQUIPMENT (1 OF 4)

Equipment	Critical Specifications	Recommended Model	Use*
Display Mainframe	HP 180T Series with variable persistence	HP 181T/TR	P, A, T
Oscilloscope	Time Base: 1 msec/cm to 10 msec/cm Vertical Sensitivity: 1 mV/cm to 20 V/cm	HP 1741A	A, T
Frequency Counter	Frequency Range: 150 MHz to 1.5 GHz Sensitivity: -30 dBm	HP 5342A	P, A, T
Timer/Counter	Time base: 10 μ sec	HP 5308A	A, T
Digital Voltmeter	Accuracy: $\pm (.05\% \text{ Rdg} \pm 1 \text{ digit})$	HP 3455A	P, A, T
Power Meter	Power Range: -20 dBm to +10 dBm	HP 435A/B	P, A, T
Power Sensor	Frequency Range: 100 kHz to 1.5 GHz Maximum SWR: 1.1, 0.1 to 1 GHz	HP 8482A	P, A, T
Amplifier	Frequency Range: 200 MHz to 300 MHz Gain: >20 dB Impedance: 50 Ω	HP 8447D	P, A, T
Signal Generator (2 required)	Frequency Range: 4 MHz to 305 MHz Drift: Less than 50 ppm (or 5 Hz, whichever is greater) Harmonic Distortion: >30 dB below fundamental Noise Sidebands: >80 dB down, 50 kHz away, 1 kHz BW	HP 8640B	P, A, T
Tracking Generator	Frequency Range: 5 MHz to 1500 MHz	HP 8444A, Opt. 059	P, T
Sweep Oscillator	Manual Sweep	HP 8350A	A
RF Plug-In	Frequency Range: 10 MHz to 1.5 GHz Flatness (external leveling): $< \pm 0.1 \text{ dB}$	HP 83522A	A
Spectrum Analyzer	Frequency Range: 10 MHz to 1.5 GHz	HP 141T/8552B/8555A	T
Comb Generator	Accuracy: 0.01%	HP 8406A	P, A, T
Function Generator	Frequency Range: 5 kHz to 5 MHz	HP 3310A	P, T
Crystal Detector	Frequency Range: 10 MHz to 1.5 GHz Frequency Response: $\pm 0.2 \text{ dB/octave to } 2 \text{ GHz}; \pm 0.5 \text{ dB overall}$	HP 423B	A, T
* P = Performance Test; A = Adjustment; T = Troubleshooting			

Item	Description	CD	HP Part Number
1	Board Puller, two prongs to lift PC boards	1	03950-4001
2	Extender Board: 6 pin, 12 contacts	8	08505-60109
3	Extender Board: 10 pin, 20 contacts	2	85680-60028
4	Extender Board: 22 pin, 44 contacts	8	08565-60107
5	Extender Cable Assembly, for plug-in operation out of display mainframe	9	5060-0303
6	Tuning Tool, modified 5/16-inch nut driver with modified No. 10 Allen driver	6	08555-60107
7	Alignment tool, metal tip in plastic	7	8710-0630
8	Alignment tool, non-metallic	4	8710-0033
9	Wrench, No. 2 Bristol	0	8710-0055
10	Wrench, 15/64-inch, combination	8	8710-0946
11	Wrench, 1/4-inch, open end	2	8720-0014
12	Wrench, 5/16-inch, slotted box end/open end	9	08555-20097

FIGURE 1-3. SERVICE ACCESSORIES (2 OF 2)

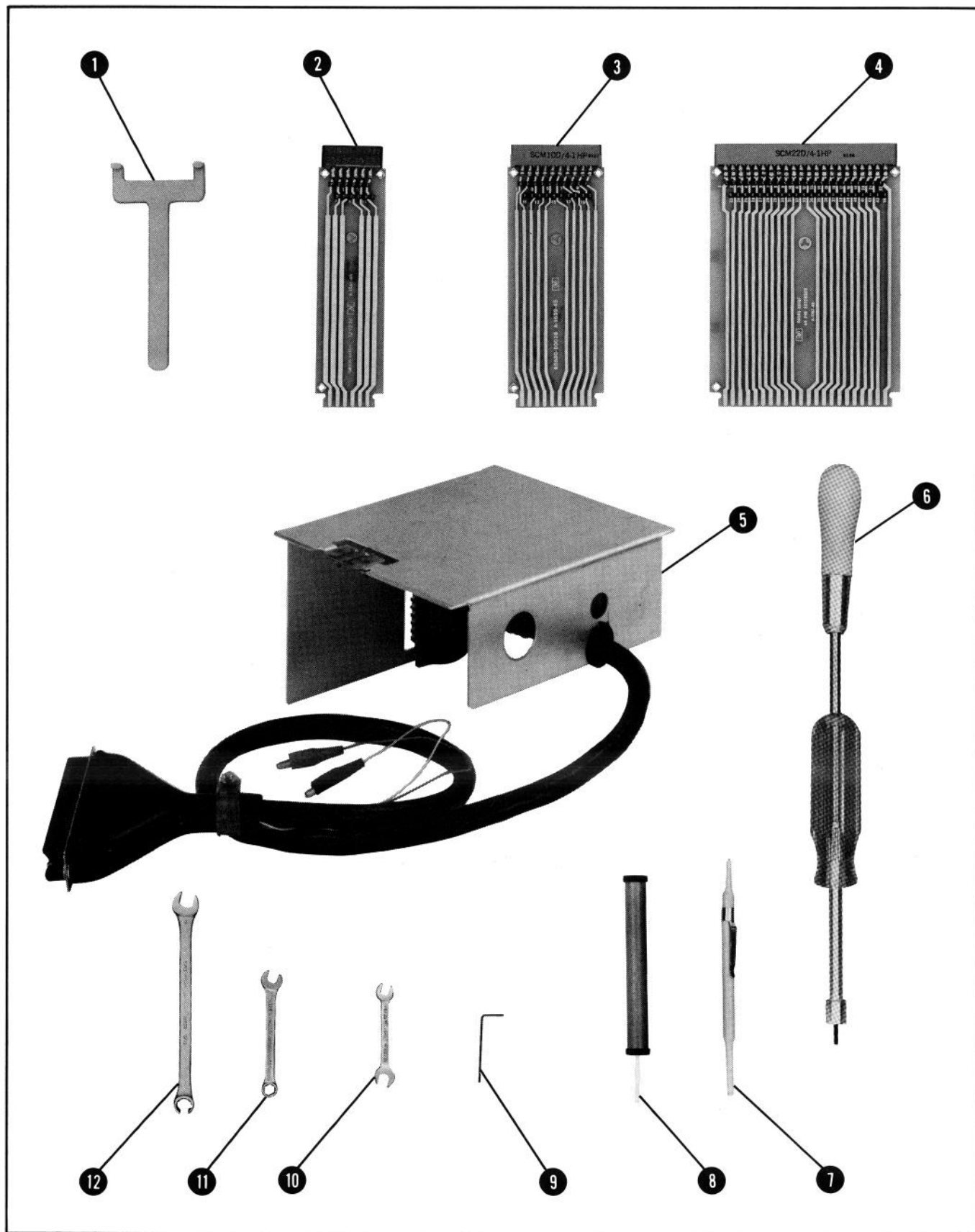

FIGURE 1-3. SERVICE ACCESSORIES (1 OF 2)

1-40. Extender Cable Assembly

1-41. An Extender Cable Assembly (Figure 1-3), HP Part Number 5060-0303, allows operation of the HP 8558B outside the display mainframe. This provides access to the HP 8558B for necessary adjustments and some performance tests. This cable is also useful for troubleshooting.

1-42. MEASUREMENT ACCESSORIES

1-43. AC Probe

1-44. The HP Model 8558B Spectrum Analyzer has a front-panel PROBE POWER connector for the use of high-impedance active probes such as the HP 1120A, HP 1121A, HP 1123A, and HP 1124A. High-impedance probes permit testing of high-frequency circuits without significant loading effects. The low-noise, AC-coupled HP 1121A is preferred for use with the HP 8558B.



The 75-ohm BNC input connector on Option 001 and 002 instruments is not compatible with 50-ohm BNC connectors. Direct connection of an AC probe might damage the input connector.

001 and 002: The AC probes have a 50-ohm output impedance. Use of a probe with the 75-ohm

Option 001 or 002 without proper impedance matching causes a +1.58 dB error in displayed signal levels.

1-45. Modification Kit (Option 807 Connections)

1-46. A modification kit, HP Part Number 00180-69503, provides the materials and information necessary to install unbuffered rear-panel connections (formerly included in Option 807) in the following display mainframes: 180A/AR, 180C/D, 181A/AR, 182A/C, and 184A/B. Refer to Table 1-3 for a description of parts included in the modification kit.

1-47. Oscilloscope Camera

1-48. The HP Model 197B, Option 002, General Purpose Camera can be used with 180- and 181-series display mainframes to make a permanent record of measurements. The HP 10367A adapter allows the camera to be used with 182-series mainframes.

1-49. SERVICE ACCESSORIES

1-50. Service accessories are shown in Figure 1-3.

1-51. RECOMMENDED TEST EQUIPMENT

1-52. Equipment required for operation verification, performance tests, adjustments, and troubleshooting of the HP Model 8558B is listed in Table 1-4. Other equipment may be substituted if it meets or exceeds the critical specifications listed in the table.

TABLE 1-3. PARTS INCLUDED IN MODIFICATION KIT 00180-69503

Quantity	Description	HP Part Number
1	Output Amplifier Assembly (Auxiliary Output Board)	00180-66551
1	Label	7120-3116
2	3/4-inch pieces of shrink tubing	0890-0720
1	Service Note	180A/AR-10, 180C/D-2, 181A/AR-8, 182A/C-1, or 184A/B-1 (modification is similar for all instruments listed)

1-22. This information should not be confused with information contained in the yellow Manual Updating supplement, which is intended to adapt this manual to instrument changes that are effected after its printing.

1-23. OPTIONS

CAUTION

The two 75-ohm BNC connectors on Option 001 and Option 002 instruments are not compatible with 50-ohm BNC connectors. Direct use of 50-ohm BNC connectors with these instruments might damage the INPUT and CAL OUTPUT connectors.

1-24. Option 001

1-25. Option 001 provides direct-measurement capability in a 75-ohm system. The BNC input and calibration-output connectors have 75 Ω impedance (nominal). Option 001 is calibrated in dBm, providing a measurement range from -110 dBm to $+30$ dBm. Throughout the manual, differences between the standard instrument and Option 001 are given in italic type following applicable text references and as necessary in tables and illustrations.

1-26. Option 002

1-27. Option 002 provides direct-measurement capability in a 75-ohm system. The BNC input and calibration-output connectors have 75 Ω impedance (nominal). Option 002 is calibrated in dBmV, providing a measurement range from -63 dBmV to $+80$ dBmV. Throughout the manual, differences between the standard instrument and Option 002 are given in italic type following applicable text references and as necessary in tables and illustrations.

1-28. Option 910

1-29. One additional Operation and Service manual is provided for each Option 910 ordered. To obtain additional manuals after initial shipment, order by the manual part number, which appears on the title page and on the back cover.

1-30. ACCESSORIES SUPPLIED

1-31. The following accessories, supplied with the instrument, are shown in Figure 1-1:

1-32. A BNC, 50-ohm termination, HP Model 11593A, is supplied for the front-panel 1ST LO OUTPUT.

1-33. A Type N male to BNC female adapter, HP Part Number 1250-0780, is supplied with the standard instrument for the use of lightweight cables with BNC connectors.

1-34. A side stop kit, HP Part Number 08558-60131, is supplied to prevent the spectrum analyzer from sliding out of the mainframe. When the side stops are installed, the plug-in cannot be removed from the mainframe. Refer to Section II for installation or removal of the side stops.

1-35. Three graticule overlays provide the operator with reference-level labels for the CRT. HP Part Number 5020-8565 is the overlay for 180-series display mainframes. HP Part Number 5020-8566 is the overlay for 181-series display mainframes. HP Part Number 5020-8567 is the overlay for 182-series display mainframes. For proper installation of the graticule overlay, refer to Section II.

1-36. EQUIPMENT REQUIRED BUT NOT SUPPLIED

1-37. Display Mainframe

1-38. An HP 853A digital Spectrum Analyzer Display is recommended for use with the HP 8558B. The rear panel of the HP 853A mainframe provides the following output connections: HORIZ (SWEEP), VERTICAL (VIDEO), BLANK (PENLIFT), 21.4 MHz IF, and HP-IB interface connector.

1-39. An HP 180T-series display mainframe (180TR, 181T, or 182T) is also designed for use with the HP 8558B. In the HP 180T-series mainframe, the rear-panel auxiliary output connectors (AUX A, AUX B, AUX C, and AUX D) provide, respectively, Vertical Output, Pen Lift Output, 21.4 MHz IF Output, and Horizontal Output. A standard HP 180-series display mainframe (HP 180A/AR, HP 180C/D, HP 181A/AR, HP 182A/C, or HP 184A/B) provides only horizontal, vertical, and blanking rear panel outputs. Furthermore, these outputs are attenuated and shifted in dc level. Unbuffered rear panel outputs (similar to the HP 180T-series) are provided only if Option 807 is installed.

TABLE 1-2. HP MODEL 8558B/180-SERIES SUPPLEMENTAL CHARACTERISTICS (3 OF 3)

SUPPLEMENTAL CHARACTERISTICS

NOTE: Values in this table are not specifications. They are typical characteristics included for user information.

CAL OUTPUT

−30 dBm at 280 MHz with second through fourth harmonics greater than −70 dBm (into 50 ohms).

001: −30 dBm at 280 MHz (into 75 ohms)

002: +20 dBmV at 280 MHz (into 75 ohms)

1ST LO OUTPUT

+10 dBm nominal into 50 ohms, 2.05–3.55 GHz.
Terminate with a 50-ohm load when not in use.

PROBE POWER

+15V, −12.6V, and GND (150 mA maximum) for use with HP High-Impedance Probes (i.e. HP 1120A, 1121A, 1123A, 1124A). The HP 1121A is recommended for its low noise characteristics.¹

REAR PANEL OUTPUT CHARACTERISTICS²

VERTICAL, PENLIFT/BLANKING, AND HORIZONTAL OUTPUTS (AUX A, B, D)

These outputs are compatible with and may be used to drive HP X-Y Recorders (using positive pencoils or TTL penlift input) and CRT monitors.

¹ See Section II for details regarding use with 001 and 002 75-ohm inputs.

² Rear panel outputs refer to 180T-series display mainframes and other 180-series mainframes with Option 807 installed. Horizontal, vertical, and blanking outputs, attenuated and shifted in dc level, are available on other 180-series mainframes at the MAIN SWEEP, MAIN GATE, and DELAYED GATE outputs, respectively. DO NOT connect an X-Y recorder to the DELAYED GATE OUTPUT, or damage will result.

AUX A VERTICAL OUTPUT

BNC output provides detected video signal from a 50-ohm output impedance. Typical 0–800 mV range corresponds to full 8-division CRT vertical deflection.

AUX B PENLIFT/BLANKING OUTPUT

BNC output provides a +15V penlift/blanking signal from a 10K-ohm output impedance when CRT trace is blanked. Otherwise, output is low at 0V (low impedance, 150 mA max.) for an unblanked trace.

AUX C 21.4 MHz IF OUTPUT

BNC output provides 21.4 MHz IF signal (linearly related to spectrum analyzer RF input) from a 50-ohm output impedance. Output bandwidth controlled by spectrum analyzer RESOLUTION BW setting; output amplitude controlled by INPUT ATTEN, REFERENCE LEVEL FINE, and first six REFERENCE LEVEL positions (i.e. −10 through −60 dBm with 0 dB input attenuation). Output level is approximately −10 dBm into 50 ohms with a signal displayed at Reference Level. 002: (i.e. +40 to −10 dBmV with 0 dB input attenuation).

AUX D HORIZONTAL OUTPUT

BNC output provides horizontal sweep voltage from a 5K-ohm output impedance. −5V to +5V range corresponds to full 10-division CRT horizontal deflection.

TABLE 1-2. HP MODEL 8558B/180-SERIES SUPPLEMENTAL CHARACTERISTICS (2 OF 3)

SUPPLEMENTAL CHARACTERISTICS

NOTE: Values in this table are not specifications. They are typical characteristics included for user information.

GAIN COMPRESSION

Gain compression is typically less than 1 dB for a -10 dBm input level with 0 dB input attenuation.

001: -5 dBm input level

002: +45 dBmV input level

AMPLITUDE SCALE SWITCHING

Reference Level variation is typically less than ±1 dB for any change in Amplitude Scale.

SPURIOUS RESPONSES

SECOND HARMONIC AND THIRD ORDER INTERMODULATION DISTORTION

The graphs below illustrate typical second harmonic and third order intermodulation distortion.

SWEEP CHARACTERISTICS

SWEEP TIME

CALIBRATED SWEEP TIME ACCURACY

(Sec/DIV, mSec/DIV)

Sweep times are typically ±10% of indicated value.

MANUAL

Spectrum analyzer may be swept manually, in either direction, with front panel control.

SWEEP TRIGGER

FREE RUN

End of each sweep triggers new sweep.

LINE

Sweep triggered at ac line frequency.

VIDEO

Sweep triggered on post-detection video waveform. One-half major division of vertical deflection required to trigger sweep.

SINGLE

Single sweep started or reset by turning SWEEP TRIGGER clockwise momentarily.

FRONT PANEL INPUT AND OUTPUT CHARACTERISTICS

SIGNAL INPUT

INPUT IMPEDANCE

50 ohms nominal; Precision Type N female connector.

001 and 002: 75 ohms nominal; 75-ohm BNC female connector.

INPUT SWR

<1.5 SWR with ≥10 dB input attenuation

001 and 002: <1.5 SWR

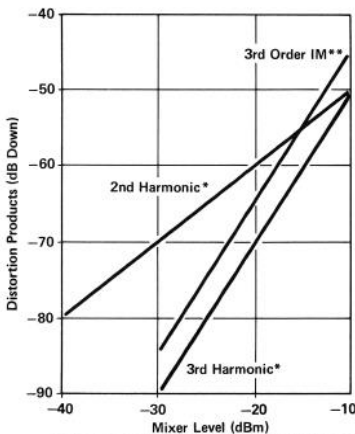

Mixer Level = Input signal level - INPUT ATTEN
 *single input signal ≥ 5 MHz
 **two equal input signals ≥ 5 MHz, ≥ 200 kHz separation

(Standard HP 8558B)

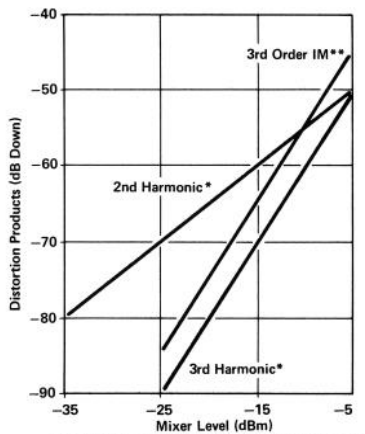

Mixer Level = Input signal level - INPUT ATTEN
 *single input signal ≥ 5 MHz
 **two equal input signals ≥ 5 MHz, ≥ 200 kHz separation

(Option 001)

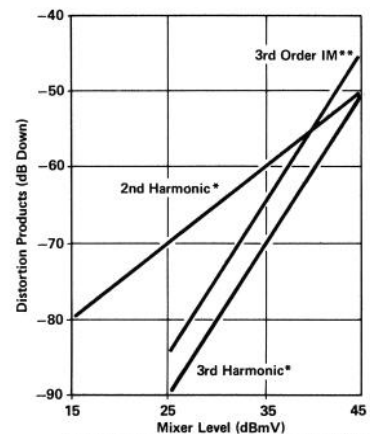

Mixer Level = Input signal level - INPUT ATTEN
 *single input signal ≥ 5 MHz
 **two equal input signals ≥ 5 MHz, ≥ 200 kHz separation

(Option 002)

Distortion vs. Mixer Level

TABLE 1-2. HP MODEL 8558B/180-SERIES SUPPLEMENTAL CHARACTERISTICS (1 OF 3)

SUPPLEMENTAL CHARACTERISTICS

NOTE: Values in this table are not specifications. They are typical characteristics included for user information.

FREQUENCY CHARACTERISTICS

FREQUENCY ACCURACY

FREQUENCY ZERO

Adjusts digital FREQUENCY MHz readout. FREQUENCY ZERO control may be used to calibrate the frequency readout on a known signal or on the LO feedthrough.

FREQUENCY CAL

Removes tuning hysteresis from first LO (YIG oscillator). FREQUENCY CAL button should be pressed to maintain FREQUENCY MHz readout accuracy whenever TUNING is changed by more than 50 MHz.

FREQUENCY RANGE

OUT-OF-RANGE BLANKING

The CRT trace is automatically blanked whenever the spectrum analyzer is swept or tuned beyond its frequency range (approximately -50 MHz and 1600 MHz).

SPECTRAL RESOLUTION AND STABILITY

FREQUENCY DRIFT

At fixed start/center frequency, after 2-hour warmup: <50 kHz in 10 minutes.

With temperature changes: <200 kHz/°C

RESOLUTION BANDWIDTH SHAPE

Approximately gaussian (synchronously-tuned, 4-pole filter).

SPECTRAL RESOLUTION

The following graph shows typical spectrum analyzer resolution for different resolution bandwidths.

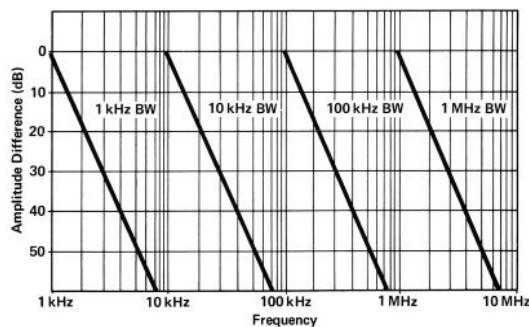

Signal Resolution vs. Frequency Separation

AMPLITUDE CHARACTERISTICS

AMPLITUDE RANGE AND ACCURACY

DYNAMIC RANGE

Maximum power ratio of two signals simultaneously

present at the input that may be measured within the limits of specified accuracy, sensitivity, and distortion (i.e. spurious responses): >70 dB

FREQUENCY RESPONSE AND AVERAGE NOISE LEVEL

The following graphs show typical frequency response and average noise level versus frequency.

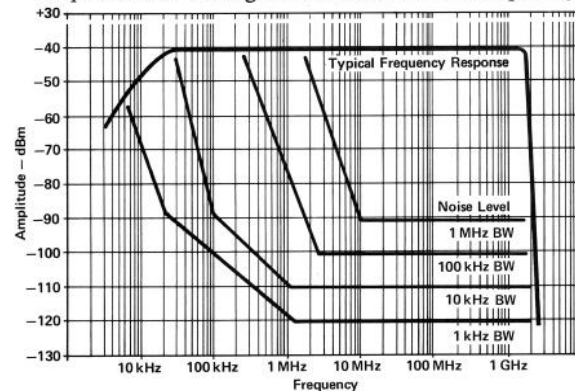

(Standard HP 8558B)

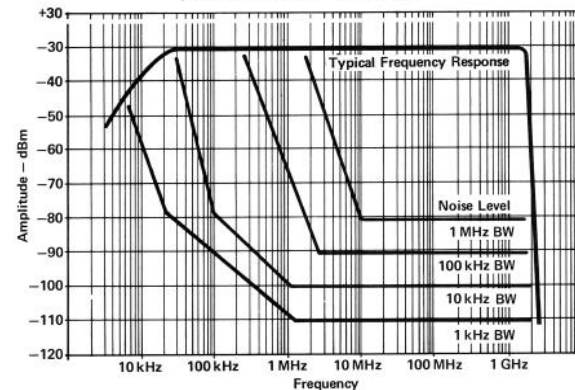

(Option 001)

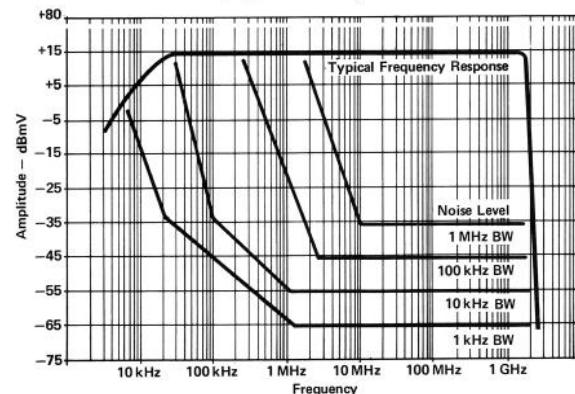

(Option 002)

Average Noise Level and Frequency Response

TABLE 1-1. HP MODEL 8558B SPECIFICATIONS (4 OF 4)

DIMENSIONS

HP Model 8558B Spectrum Analyzer:

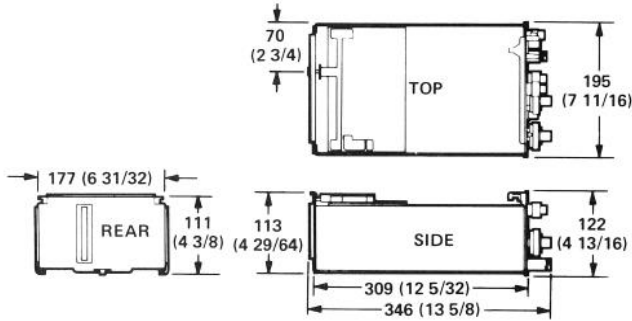

HP Model 182T Display:

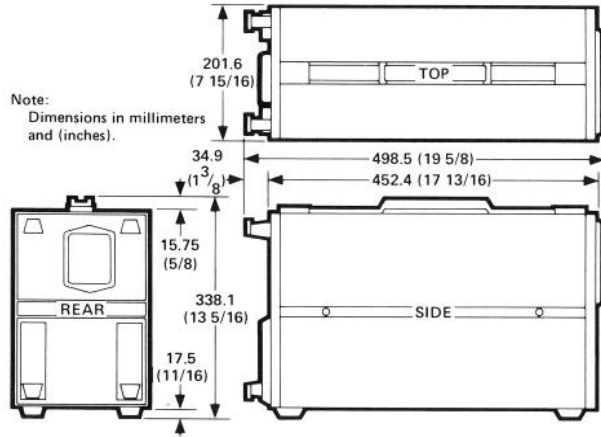

HP Model 853A Display:

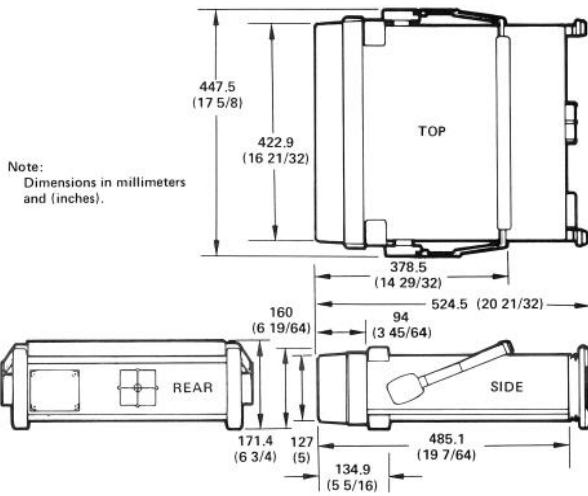

HP Model 181T Display:

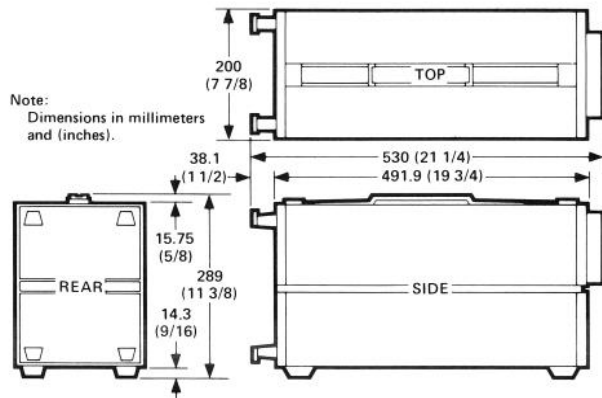

HP Model 853A Option 001 Display:

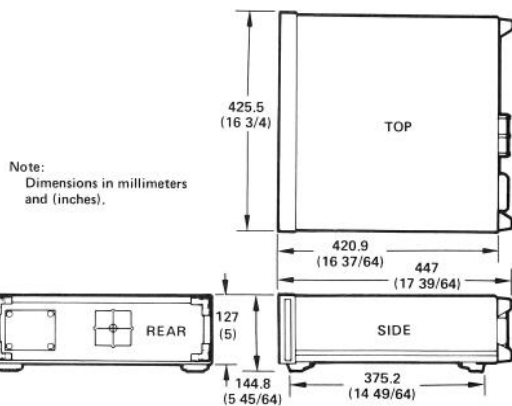

HP Model 180TR/181TR Display:

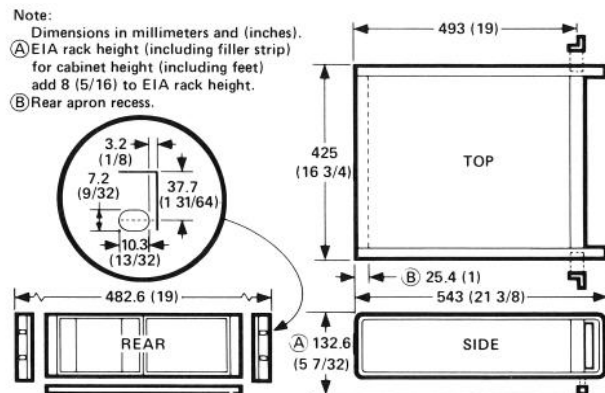

TABLE 1-1. HP MODEL 8558B SPECIFICATIONS (3 OF 4)

POWER REQUIREMENTS**HP Model 853A Display with HP Model 8558B Spectrum Analyzer:**

100 or 120 Vac +5%–10%, 48 to 66 Hz, single-phase. Power consumption is less than 200 VA with plug-in installed.

HP Model 182T/180TR Display with HP Model 8558B Spectrum Analyzer:

115 or 230 Vac \pm 10%, 48 to 440 Hz. Power consumption is less than 200 VA with plug-in installed, convection cooled.

HP Model 181T/181TR Display with HP Model 8558B Spectrum Analyzer:

115 or 230 Vac \pm 10%, 48 to 440 Hz. Power consumption is less than 225 VA with plug-in installed, convection cooled.

WEIGHT**HP Model 8558B Spectrum Analyzer:**

Net: 5.5 kg (12 lbs)

Shipping: 10.5 kg (23 lbs)

HP Model 853A Display:

Net: 15.9 kg (35 lbs)

Shipping: 18.6 kg (41 lbs)

HP Model 853A Option 001 Display:

Net: 14.5 kg (32 lbs)

Shipping: 17.3 kg (38 lbs)

HP Model 182T Display:

Net: 12.5 kg (27 lbs)

Shipping: 16.5 kg (36 lbs)

HP Model 181T Display:

Net: 11.0 kg (24 lbs)

Shipping: 15.5 kg (34 lbs)

HP Model 181TR Display:

Net: 12.0 kg (26 lbs)

Shipping: 17.5 kg (38 lbs)

HP Model 180TR Display:

Net: 12.0 kg (26 lbs)

Shipping: 17.5 kg (38 lbs)

TABLE 1-1. HP MODEL 8558B SPECIFICATIONS (2 OF 4)

Reference Level

10-dB steps and a 12-dB vernier for calibrated Reference Level adjustment from -112 dBm to $+60$ dBm.

*002: -62 dBmV to $+110$ dBmV*¹

Step Accuracy:

Steps referenced with 0 dB input attenuation.

-10 dBm to -80 dBm: ± 0.5 dB

-10 dBm to -100 dBm: ± 1.0 dB

Vernier Accuracy

± 0.5 dB

Frequency Response

Frequency response includes input attenuator, limiter, and mixer flatness:

$\leq \pm 1.0$ dB with 10 dB input attenuation

Input Attenuator

0 dB to 70 dB of input attenuation selectable in 10-dB steps

Step Accuracy:

0 dB to 70 dB: $< \pm 0.5$ dB per 10-dB step

Maximum Cumulative Error:

0 dB to 70 dB: $< \pm 1.0$ dB

Bandwidth Switching (Amplitude Variation)

Bandwidths 3 MHz to 300 kHz: $< \pm 0.5$ dB

Bandwidths 3 MHz to 1 kHz: $< \pm 1.0$ dB²

Display Fidelity

CRT linearity and log or linear fidelity affect amplitude accuracy at levels other than Reference Level.

Log Incremental Accuracy:

± 0.1 dB per dB from Reference Level

Log Maximum Cumulative Error:

$\leq \pm 1.5$ dB over entire 70-dB range

Linear Accuracy:

$\pm 3\%$ of Reference Level

SPURIOUS RESPONSES**Second Harmonic Distortion:**

> 70 dB³ below a -40 dBm input signal with 0 dB input attenuation.

001: -35 dBm input signal

002: $+15$ dBmV input signal

Third Order Intermodulation Distortion:

> 70 dB³ below two -30 dBm input signals, separated by ≥ 50 kHz, with 0 dB input attenuation.

001: two -25 dBm input signals

002: two $+25$ dBmV input signals

Image and Multiple Responses:

> 70 dB³ below a -40 dBm input level with 0 dB input attenuation.

001: -35 dBm input level

002: $+15$ dBmV input level

RESIDUAL RESPONSES

< -100 dBm (1–1500 MHz) with 0 dB input attenuation and no signal present at input.

001: < -95 dBm (1–1500 MHz)

002: < -50 dBmV (1–1500 MHz)

SWEEP SPECIFICATIONS**SWEEP TIME****Automatic (AUTO):**

Sweep time adjusted automatically to maintain absolute amplitude calibration for any combination of frequency span, resolution bandwidth, and video filter bandwidth.

Calibrated Sweep Times (sec/Div, mSec/Div):

16 selectable sweep times in 1-2-5 sequence from 0.1 msec/div to 10 sec/div, provided primarily for time-domain calibration in zero span (0).

GENERAL SPECIFICATIONS**TEMPERATURE RANGE**

Operating: 0°C to $+55^{\circ}\text{C}$

Storage: -40°C to $+75^{\circ}\text{C}$.

HUMIDITY RANGE

Type-tested from 50% to 95% relative humidity ($\leq +40^{\circ}\text{C}$) per requirements of MIL-STD-810C, Method 507.1, Procedure IV.

EMI

Conducted and radiated interference is in compliance with MIL-STD 461A, Methods CE03 and RE02, CISPR Publication 11 (1975) and Messemmpfaenger Postverfuegung 526/527/79 (Kennzeichnung Mit F-Nummer/Funkschutzzeichen).

¹ Input level not to exceed $+30$ dBm (*002: $+80$ dBmV*) damage level.

² 100 kHz bandwidth limited to $< 80\%$ relative humidity. Amplitude variation is $< \pm 2.5$ at 95% relative humidity, $+40^{\circ}\text{C}$.

³ > 60 dB for 100 kHz to 5 MHz input signals.

TABLE 1-1. HP MODEL 8558B SPECIFICATIONS (1 OF 4)

FREQUENCY SPECIFICATIONS	Video Filter
<p>FREQUENCY RANGE 100 kHz to 1500 MHz</p> <p>FREQUENCY SPANS Per Division (MHz/Div, kHz/Div) 14 frequency scale calibrations in 1-2-5 sequence from 5 kHz/div to 100 MHz/div. Start or center frequency is set with the TUNING control and indicated by the FREQUENCY MHz readout. Zero Span (0) Analyzer functions as a manually tuned receiver, at the frequency indicated by the FREQUENCY MHz readout, for time-domain display of signal modulation.</p> <p>FREQUENCY ACCURACY Tuning Accuracy Frequency MHz readout (start or center frequency), after zeroing on the LO feedthrough and operating the FREQUENCY CAL control, +10°C to +40°C: 0–195 MHz: $\pm(1 \text{ MHz} + 20\% \text{ of frequency span per division})$ 195–1500 MHz: $\pm(5 \text{ MHz} + 20\% \text{ of frequency span per division})$ Frequency Readout Resolution 0–195 MHz: 100 kHz 195–1500 MHz: 1 MHz Frequency Span Accuracy $\pm 5\%$ of displayed frequency separation</p> <p>SPECTRAL RESOLUTION AND STABILITY Resolution Bandwidths Eight selectable resolution (3-dB) bandwidths in 1-3 sequence from 1 kHz to 3 MHz. Bandwidth may be selected independently or coupled with frequency span. Optimum ratio of frequency span to resolution bandwidth is indicated by alignment of markers (> <) on the two controls. Resolution Bandwidth Accuracy: Individual resolution bandwidth 3-dB points: $\pm 20\%$ (+10°C to +40°C) Selectivity: 60-dB: 3-dB resolution bandwidth ratio: <15:1</p> <p>Stability Residual FM: <1 kHz p-p in 0.1 second Noise Sidebands: $\geq 65 \text{ dB down, } > 50 \text{ kHz from center of CW signal with 1 kHz resolution bandwidth and full video filtering.}$</p>	<p>Post-detection low-pass filter averages displayed noise for a smooth trace. The MAX (detent) position selects a video filter bandwidth of approximately 1.5 Hz for noise level measurement.</p> <p style="text-align: center;">AMPLITUDE SPECIFICATIONS</p> <p>AMPLITUDE RANGE –117 dBm to +30 dBm <i>001: –110 dBm to +30 dBm</i> <i>002: –63 dBmV to +80 dBmV</i> Maximum Input (Damage) Levels Total Power: +30 dBm (1W, 7.1 Vrms) <i>001: +30 dBm (1W, 8.7 Vrms)</i> <i>002: +80 dBmV (1.3W, 10 Vrms)</i> dc or ac (<100 Hz): $\pm 50\text{V}$ Peak Pulse Power: +50 dBm (100W, <10 μsec pulse width, 0.01% duty cycle) with input attenuation $\geq 20 \text{ dB}$ <i>002: +100 dBmV (130W)</i> Average Noise Level The displayed average noise level determines sensitivity (minimum discernible signal). Signals at this input level peak approximately 3 dB above the displayed noise. Maximum average noise level with 10 kHz resolution bandwidth, 0 dB input attenuation, and maximum (MAX) video filtering: <–107 dBm (1–1500 MHz) <i>001: <–100 dBm (1–1500 MHz)</i> <i>002: <–53 dBmV (1–1500 MHz)</i> Calibrated Display Range Log (from Reference Level): 70 dB with 10 dB/DIV Amplitude Scale 8 dB with 1 dB/DIV Amplitude Scale Linear: 8 divisions with LIN Amplitude Scale</p> <p>AMPLITUDE ACCURACY With AUTO sweep time selected, amplitude accuracy is determined by one or more of the following factors, depending on the measurement technique. Calibrator Output –30 dBm $\pm 1 \text{ dB}$ (into 50Ω) 280 MHz $\pm 300 \text{ kHz}$ <i>001: –30 dBm $\pm 1 \text{ dB}$ (into 75Ω)</i> <i>002: +20 dBmV $\pm 1 \text{ dB}$ (into 75Ω)</i></p>

1-10. SPECIFICATIONS

1-11. Instrument specifications are listed in Table 1-1. These specifications are the performance standards or limits against which the instrument is tested. Table 1-2 lists supplemental characteristics. Supplemental characteristics are not specifications but are typical characteristics included as additional information for the user.

NOTE

To ensure that the HP Model 8558B meets the specifications listed in Table 1-1, the performance tests (Section IV) should be performed every six months.

1-12. SAFETY CONSIDERATIONS

1-13. Before operating this instrument, you should familiarize yourself with the safety markings on the instrument and the safety instructions in this manual. This instrument has been manufactured and tested according to international safety standards. However, to ensure safe operation of the instrument and personal safety of the user and service personnel, the cautions and warnings in this manual must be followed. Refer to the summary of safety considerations at the beginning of this section. Refer also to individual sections of this manual for detailed safety notation concerning the use of the instrument as described in those individual sections.

1-14. INSTRUMENTS COVERED BY MANUAL

1-15. Serial Numbers

1-16. Attached to the rear of your instrument is a mylar serial number label. The serial number is in two parts. The first four digits and letter are the serial number prefix; the last five digits are the suffix (see Figure 1-2). The prefix is the same for all identical instruments; it changes only when a change is made to the instrument. The suffix, however, is assigned sequentially and is different for each instrument. The contents of this manual apply to instruments with the serial number prefix(es) listed under SERIAL NUMBERS on the title page.

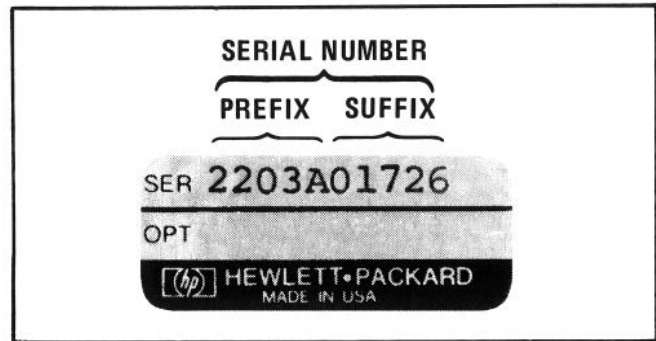

FIGURE 1-2. TYPICAL SERIAL NUMBER LABEL

1-17. Manual Updating Supplement

1-18. An instrument manufactured after the printing of this manual might have a serial number prefix that is not listed on the title page. This unlisted serial number prefix indicates that the instrument is different from those described in this manual. The manual for this newer instrument is accompanied by a yellow Manual Updating supplement. This supplement contains change information that explains how to adapt the manual to the newer instrument.

1-19. In addition to change information, the supplement may contain information for correcting errors in the manual. To keep this manual as current and accurate as possible, Hewlett-Packard recommends that you periodically request the latest Manual Updating supplement. The supplement carries a manual identification block that includes the model number, print date of the manual, and manual part number. Complimentary copies of the supplement are available from Hewlett-Packard. Addresses of Hewlett-Packard offices are located at the back of this manual.

1-20. Manual Backdating Changes

1-21. Instruments manufactured before the printing of this manual have been assigned serial number prefixes other than those for which this manual was directly written. Manual backdating information is provided in Section VII to adapt this manual to earlier serial number prefixes. For instruments with serial number prefixes 1829A and earlier, refer to the HP 8558B Operating and Service Manual dated October 1977, HP Part Number 08558-90043, and to the Manual Updating supplement supplied with that manual.

SECTION I GENERAL INFORMATION

1-1. INTRODUCTION

1-2. This Operation and Service manual contains information required to install, operate, test, adjust, and service the Hewlett-Packard Model 8558B Spectrum Analyzer. Figure 1-1 shows the standard instrument and accessories supplied. This section covers instrument identification, description, options, accessories, specifications, and other basic information.

1-3. DESCRIPTION

1-4. The HP 8558B displays the amplitude and frequency of each component of an input signal on a CRT. This display gives quantitative information often not available from a conventional oscilloscope. The HP 8558B is capable of measuring signals from -117 dBm to $+30$ dBm over a frequency range of 100 kHz to 1500 MHz.

Option 001: -110 dBm to $+30$ dBm
Option 002: -63 dBmV to $+80$ dBmV

1-5. The complete measuring system includes the HP 8558B Spectrum Analyzer plugged into a compatible Hewlett-Packard display mainframe.

1-6. MANUAL ORGANIZATION

1-7. This manual is divided into eight sections as follows:

SECTION I, GENERAL INFORMATION: contains the instrument description and specifications, explains accessories and options, and lists recommended test equipment.

SECTION II, INSTALLATION AND OPERATION VERIFICATION: contains information concerning initial mechanical inspection, preparation for use, operating environment, packaging and shipping, and operation verification.

SECTION III, OPERATION: contains detailed instructions for operation of the instrument.

SECTION IV, PERFORMANCE TESTS: contains the necessary tests to verify that the electrical operation of the instrument is in accordance with published specifications.

SECTION V, ADJUSTMENTS: contains the necessary adjustment procedures to adjust the instrument properly after repair.

SECTION VI, REPLACEABLE PARTS: contains the information necessary to order parts and/or assemblies for the instrument.

SECTION VII, MANUAL BACKDATING CHANGES: contains backdating information to make this manual compatible with earlier equipment configurations.

SECTION VIII, SERVICE: contains schematic diagrams, block diagrams, component location illustrations, parts lists, circuit descriptions, and troubleshooting information to aid in repair of the instrument.

1-8. On the title page of this manual, below the manual part number, is a microfiche part number. This number may be used to order 4- by 6-inch microfilm transparencies of the manual. Each microfiche contains up to 60 photo-duplicates of the manual pages. The microfiche package also includes the latest Manual Updating supplement.

1-9. Where text changes are required to reflect Options 001 and 002, these changes are shown in italic type immediately following applicable text. Notes are also included in tables and illustrations where users of Options 001 and 002 need to be informed of differences from the standard instrument. Users of the standard instrument should ignore references to Options 001 and 002.

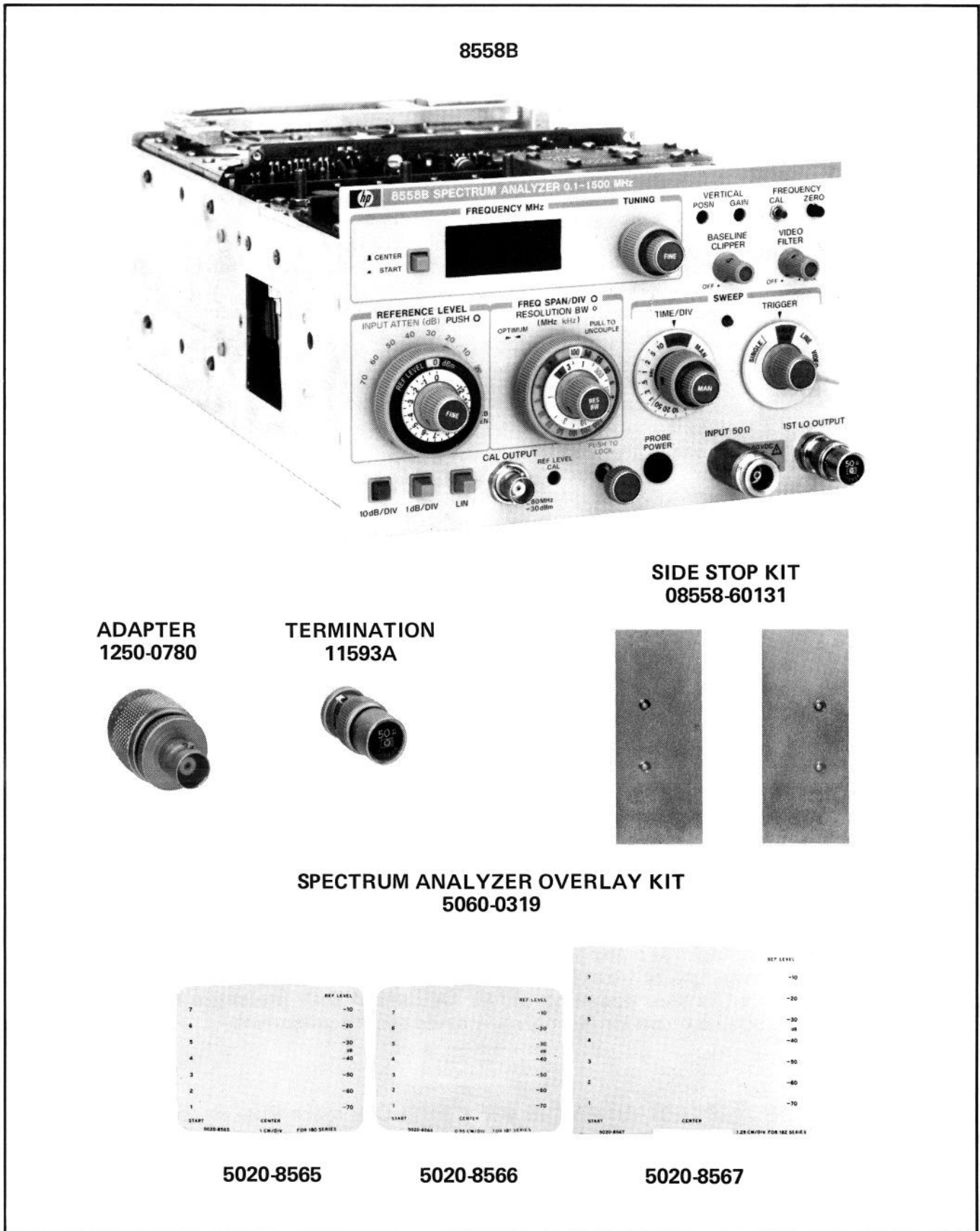

FIGURE 1-1. HP MODEL 8558B SPECTRUM ANALYZER WITH ACCESSORIES SUPPLIED

SAFETY SYMBOLS

The following safety symbols are used throughout this manual and in the instrument. Familiarize yourself with each of the symbols and its meaning before operating this instrument.



Instruction manual symbol. The instrument will be marked with this symbol when it is necessary for the user to refer to the instruction manual in order to protect the instrument against damage. Location of pertinent information within the manual is indicated by use of this symbol in the table of contents.



Indicates dangerous voltages are present. Be extremely careful.

CAUTION

The CAUTION sign denotes a hazard. It calls attention to a procedure which, if not correctly performed or adhered to, could result in damage to or destruction of the instrument. Do not proceed beyond a CAUTION sign until the indicated conditions are fully understood and met.

WARNING

The WARNING sign denotes a hazard. It calls attention to a procedure which, if not correctly performed or adhered to, could result in injury or loss of life. Do not proceed beyond a WARNING sign until the indicated conditions are fully understood and met.

GENERAL SAFETY CONSIDERATIONS

WARNING

BEFORE THIS INSTRUMENT IS SWITCHED ON, make sure it has been properly grounded through the protective conductor of the ac power cable to a socket outlet provided with protective earth contact. Any interruption of the protective (grounding) conductor, inside or outside the instrument, or disconnection of the protective earth terminal can result in personal injury.

WARNING

There are voltages at many points in the instrument which can, if contacted, cause personal injury. Be extremely careful. Any adjustments or service procedures that require operation of the instrument with protective covers removed should be performed only by trained service personnel.

CAUTION

BEFORE THIS INSTRUMENT IS SWITCHED ON, make sure its primary power circuitry has been adapted to the voltage of the ac power source. Failure to set the ac power input to the correct voltage could cause damage to the instrument when the ac power cable is plugged in.

SECTION II INSTALLATION AND OPERATION VERIFICATION

2-1. INTRODUCTION

2-2. This section includes information on initial inspection, preparation for use, and storage and shipping requirements for the HP 8558B.

2-3. INITIAL INSPECTION

2-4. Inspect the shipping container for damage. If the shipping container or cushioning material is damaged, it should be kept until the contents of the shipment have been checked for completeness and the instrument has been checked mechanically and electrically. The contents of the shipment should be as shown in Figure 1-1. The electrical performance is checked by the Operation Verification procedure in this section. If the contents are incomplete, or if the instrument does not pass Operation Verification tests, notify the nearest Hewlett-Packard office. If the shipping container is damaged, or the cushioning material shows signs of stress, notify the carrier as well as the Hewlett-Packard office. Keep the shipping materials for carrier's inspection. The HP office will arrange for repair or replacement without waiting for claim settlement.

2-5. PREPARATION FOR USE

2-6. Installation

2-7. When properly installed, the spectrum analyzer obtains all necessary power from the display mainframe. The rear panel connector provides the interface.

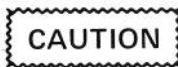

BEFORE SWITCHING ON THIS INSTRUMENT, make sure it is adapted to the voltage of the ac power source to be used and the proper fuse is installed. Failure to set the ac power input of the instrument for the correct voltage level could cause damage to the instrument

when plugged in. Refer to the display mainframe Operation and Service Manual for line voltage and fuse selection.

2-8. To install the spectrum analyzer in the mainframe:

- a. Set display mainframe LINE switch to OFF.
- b. Pull out lock knob and slide plug-in toward rear of compartment until it is seated firmly in place.
- c. Push in lock knob to secure spectrum analyzer in mainframe.

2-9. Side Stop Kits

2-10. Side stops unique to the installation of this instrument into the HP 853A Spectrum Analyzer Display are included with the HP 853A. Refer to the HP 853A Operation and Service Manual for further information.

2-11. Installation of a Side Stop Kit, HP Part Number 08558-60131, prevents the removal of the analyzer from the HP 180-Series mainframe without the use of hand tools. This kit contains two side stops, mounting hardware, label, and installation instructions. (Refer to Table 2-1 for part numbers of individual items.)

TABLE 2-1. SIDE STOP KIT (08558-60131)

Qty	Description	HP Part Number	C D
2	SIDE STOP	08558-00094	7
4	MACHINE SCREW, 4-40 .438 IN-LG 82 DEG FLATHEAD	2200-0168	9
1	LABEL, FRONT-PANEL	7120-8131	7
1	LABEL, INSTRUCTIONS	7120-8215	8

2-12. To install side stops:

WARNING

Before removing covers from display mainframe, disconnect line power by removing ac power cord.

1. Remove side covers from bottom section of mainframe. (Remove only right side cover if mainframe is a rack-mounted model.)
2. Use flathead machine screws to install side stops as shown in Figure 2-1.
3. Reinstall side covers on mainframe.

4. Place label on front panel of spectrum analyzer (upper right-hand corner) to indicate that the plug-in is secured with side stops.

2-13. To remove side stops:

WARNING

Before removing covers from display mainframe, disconnect line power by removing ac power cord.

1. Remove side covers from bottom section of mainframe. (Remove only right side cover if mainframe is a rack-mounted model.)
2. Remove side stops. See Figure 2-1.
3. Reinstall side covers on display mainframe.

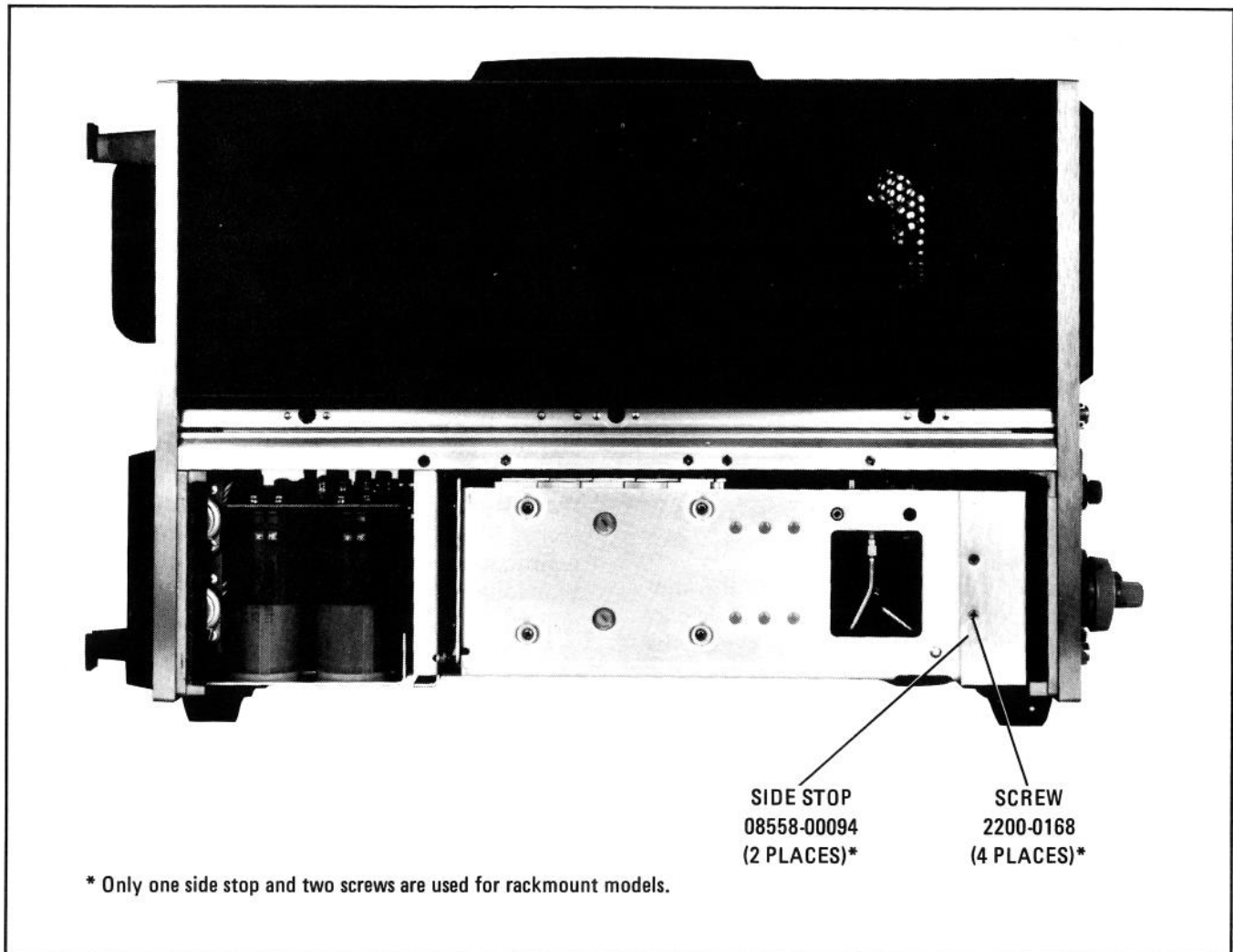

FIGURE 2-1. LOCATION OF SIDE STOPS

2-14. Graticule Overlays

2-15. To install a graticule overlay:

1. Select proper overlay. HP Part Number 5020-8565 is for HP 180TR display mainframes, HP Part Number 5020-8566 is for HP 181T/TR display mainframes, and HP Part Number 5020-8567 is for HP 182T display mainframes.
2. For HP 180TR and HP 181T/TR mainframes, remove CRT bezel and metallic-mesh contrast filter. Insert proper overlay and replace contrast filter and CRT bezel.
3. For HP 182T mainframes, grasp top portion of CRT bezel and pull straight up. Remove metallic-mesh contrast filter and insert proper overlay and contrast filter. (Either the metallic-mesh contrast filter or a light blue contrast filter may be used.)
4. Slide bezel back into place to retain overlay and filter.

2-16. Mainframe Interconnections

2-17. When the HP 8558B is properly installed in the display mainframe, the interconnections are as listed in Table 2-2.

2-18. Operating Environment

2-19. Temperature. The instrument may be operated in temperatures from 0°C to +55°C.

2-20. Humidity. The instrument may be operated in environments with relative humidity from 5 percent to 95 percent, 0°C to +40°C. The recommended long-term operating environment is 5 percent to 80 percent relative humidity. The instrument should also be protected from abrupt temperature changes that cause internal condensation.

2-21. Altitude. The instrument may be operated in altitudes up to 4572 meters (15,000 feet).

2-22. Modifications

2-23. A Modification Kit, HP Part Number 00180-69503, provides materials and information necessary to add Option 807 rear-panel connections to the standard HP 180-series display. Refer to Table 1-3 in Section I. Option 807 is factory-installed in HP 180TR, HP 181T, HP 181TR, and HP 182T mainframes. The modification kit is required for use with other HP 180-series mainframes if all four rear-panel outputs are needed.

TABLE 2-2. HP MODEL 8558B MAINFRAME INTERCONNECTIONS

Pin on P1	Signal or Voltage	Pin on P1	Signal or Voltage
1	CRT HORIZ (adjusted horizontal signal)	17	BLANKING
2	GROUND from mainframe (jumpered to pin 8)	18	NC
3	NC	19	GROUND from mainframe (jumpered to pin 24)
4	L NORM	20	AUTO SWP
5	Y NORM	21	BEAM FINDER
6	NC	22	NC
7	SING SWP	23	NC
8	GROUND from mainframe (jumpered to pin 2)	24	GROUND from mainframe (jumpered to pin 19)
9	MAN SWP	25	NC
10	NC	26	NC
11	AUX D Horizontal Output (to mainframe rear panel)	27	NC
12	AUX C 21.4 MHz IF Output (to mainframe rear panel)	28	- 12.6 Vdc from mainframe
13	AUX B Penlift/Blanking Output (to mainframe rear panel)	29	+ 15 Vdc from mainframe
14	AUX A Vertical Output (to mainframe rear panel)	30	+ 100 Vdc from mainframe
15	GROUND	31	30V p-p from mainframe (for LINE TRIGGER)
16	NC	32	NC
		W10P3 (2 contacts)	+ VERT (top contact, yellow wire) - VERT (bottom contact, orange wire)

2-24. STORAGE AND SHIPMENT

2-25. Environment

2-26. The instrument may be stored or shipped in environments within the following limits:

Temperature: -40°C to $+75^{\circ}\text{C}$
Humidity: 5% to 95% (0°C to $+40^{\circ}\text{C}$)
Altitude: Up to 15240 meters (50,000 feet)

The instrument should also be protected from temperature extremes which cause condensation within the instrument.

2-27. Packaging

2-28. Original Packaging. Containers and materials identical to those used in factory packaging are available through Hewlett-Packard offices. If the instrument is being returned to Hewlett-Packard for servicing, attach a tag indicating the type of service required, return address, model number, and full serial number. A supply of these tags is provided at the end of this section. Also mark the container FRAGILE to assure careful handling. In any correspondence, refer to the instrument by model number and full serial number.

2-29. Other Packaging. The following general instructions should be used for repackaging with commercially available materials:

1. Wrap the instrument in heavy paper or plastic. If shipping to a Hewlett-Packard office or service center, attach a tag indicating the type of service required, return address, model number, and full serial number. A supply of these tags is provided at the end of this section.

2. Use a strong shipping container. A double-wall carton made of 350-pound test material is adequate.
3. Use enough shock-absorbing material (3-inch to 4-inch layer) around all sides of the instrument to provide firm cushion and prevent movement inside the container. Protect the control panel with cardboard.
4. Seal the shipping container securely.
5. Mark the shipping container FRAGILE to assure careful handling.

2-30. OPERATION VERIFICATION

2-31. The Operation Verification tests only the most critical specifications and operating features of the instrument. It requires much less time and equipment than the complete performance tests provided in Section IV, and is recommended for verification of overall instrument operation, either as part of incoming inspection or after repair. Operation Verification consists of the following performance tests:

- Paragraph 4-11, Frequency Span Accuracy
- Paragraph 4-17, Average Noise Level
- Paragraph 4-21, Bandwidth Switching (Amplitude Variation)
- Paragraph 4-22, Input Attenuator Accuracy
- Paragraph 4-24, Display Fidelity
- Paragraph 4-25, Calibrator Accuracy

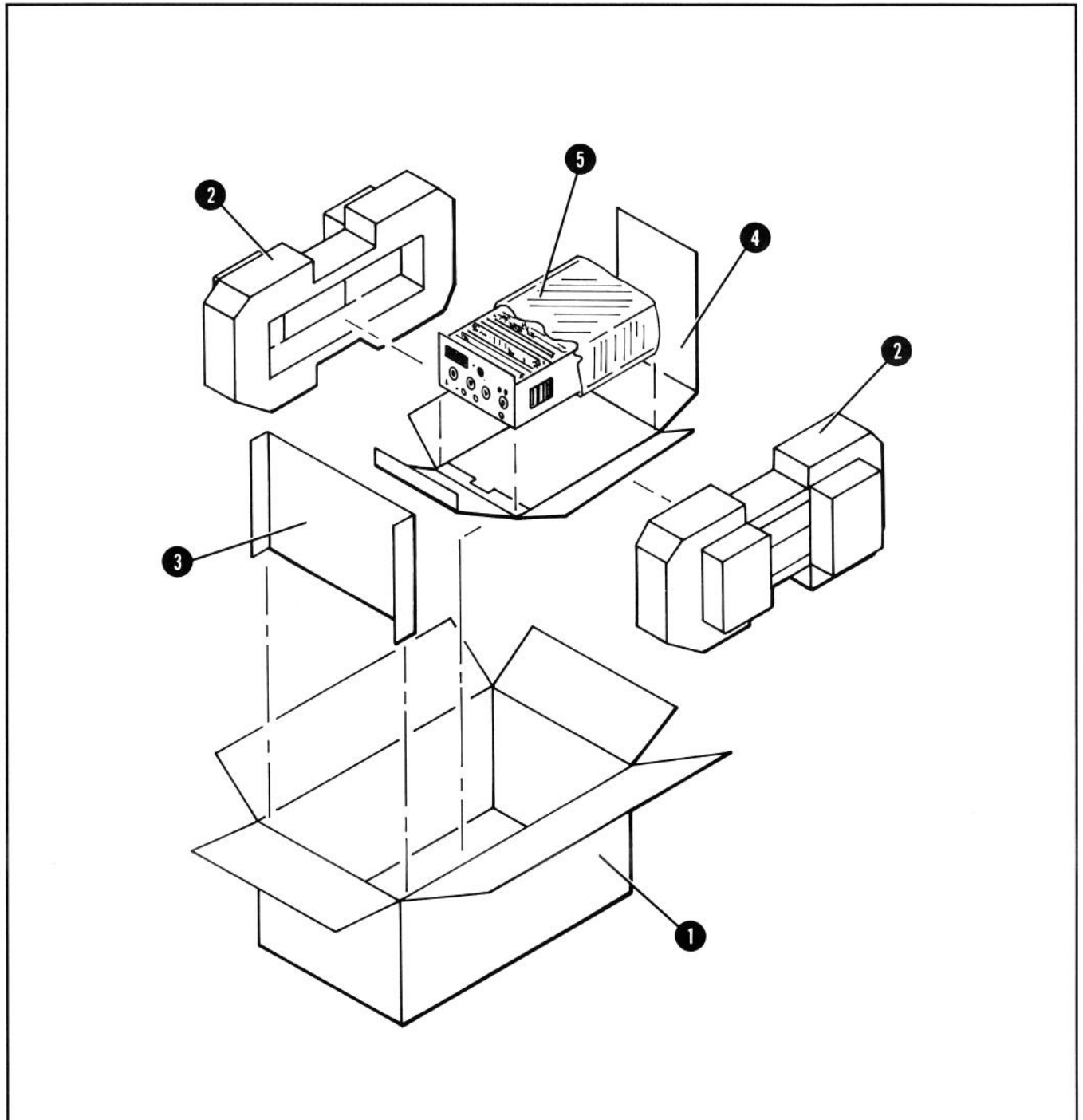

Item	Qty	C D	HP Part Number	Description
1	1	4	9211-3026	CARTON – OUTER
2	2	1	9220-3024	FOAM PADS – INNER
3	1	7	9220-3129	MANUAL PAD – FRONT
4	1	9	9220-3048	CARTON – INNER
5	1	7	9222-1054	BAG – ANTISTATIC

FIGURE 2-2. PACKAGING FOR SHIPMENT USING FACTORY PACKAGING MATERIALS

SECTION III OPERATION

3-1. INTRODUCTION

3-2. This section provides operating information for the HP 8558B Spectrum Analyzer plug-in. It also provides a brief description of display mainframe controls. For a detailed description of the display mainframe, refer to its manual.

3-3. The HP 8558B Spectrum Analyzer plug-in can be used with either the HP 180-Series display mainframes or the HP 853A Spectrum Analyzer Display mainframe.

3-4. DESCRIPTION

3-5. HP 8558B Spectrum Analyzer

3-6. The HP 8558B Spectrum Analyzer plug-in has a measurement range of 100 kHz to 1500 MHz, and can display frequency spans from 50 kHz to 1000 MHz. A four-digit LED readout indicates the spectrum analyzer start or center frequency with a resolution of 1 MHz or 100 kHz. The HP 8558B can be used to measure signals over an amplitude range of -117 dBm to +30 dBm. A front-panel 1ST LO OUTPUT is provided for stimulus/response measurements, using the HP 8444A Option 059 Tracking Generator.

3-7. The HP 853A Spectrum Analyzer Display is a large-screen, digital storage display mainframe for use exclusively with the HP 8559A, 8558B, and 8557A Spectrum Analyzer plug-ins. Digital memory provides buffer storage for two independent traces, both of which can be displayed or blanked as desired. Digital processing also provides pushbutton features such as maximum signal hold, digital averaging, and trace normalization. A conventional analog display mode can also be selected.

3-8. HP-IB

3-9. The HP 853A has limited HP-IB capabilities. CRT trace and graticule data is dumped directly to a listen-only HP-IB plotter by pressing two front-panel pushbuttons. Control setting on the spectrum analyzer plug-in cannot be monitored via the HP-IB; however, all digital display functions are programmable via a controller, and two lines of annotation

can be displayed on the CRT for labelling purposes or operator prompting. In addition, controller commands allow transfer of trace data for analysis or storage.

3-10. CONTROLS, INDICATORS, AND CONNECTORS

3-11. Control Grouping

3-12. The Spectrum Analyzer plug-in and Display mainframe front-panel controls fall into three general groups: those that deal with the displays, those that deal with frequency, and those that deal with amplitude. These controls are shown in Figure 3-1 and accompanied by detailed explanations of their use.

3-13. **Display.** The display group consists of:

SWEEP TIME/DIV	VIDEO FILTER
SWEEP TRIGGER	BASELINE CLIPPER
VERT POSN	HORIZONTAL
VERT GAIN	POSITION
MANUAL SWEEP	INTENSITY
HORIZ GAIN (rear panel of HP 8558B)	FOCUS
	TRACE ALIGN

3-14. The display group enables the operator to calibrate the display and to select a variety of scan and display conditions. However, when the SWEEP TIME/DIV control is placed in the AUTO position, sweep time is controlled by the RESOLUTION BW, FREQ SPAN/DIV, and VIDEO FILTER controls.

3-15. **Frequency.** The frequency group consists of:

TUNING
RESOLUTION BW
FREQ SPAN/DIV

3-16. The frequency group enables the operator to control how the Spectrum Analyzer displays the frequency domain. The RESOLUTION BW and FREQ SPAN/DIV controls, when pushed in, are coupled together, and moving either control moves the other. When the SWEEP TIME/DIV control is in the AUTO position, varying the RESOLUTION BW or

the **FREQ SPAN/DIV** (coupled or uncoupled) will change the sweep time to maintain calibration. With the two controls coupled together in the optimum position, **RESOLUTION BW's** of 3 MHz to 1 kHz will be automatically selected as the **FREQ SPAN/DIV** is narrowed from 100 MHz to 0 (Zero). **TUNING** controls coarse and fine (coarse is the larger knob) set the center frequency of the displayed spectrum. **RESOLUTION BW** control determines the resolution of the signals of the CRT.

3-17. Amplitude. The amplitude group consists of:

REFERENCE LEVEL dBm
 INPUT ATTEN
 REF LEVEL FINE
 REF LEVEL CAL
 10 dB/DIV – 1dB/DIV – LIN (Amplitude Scale)

3-18. The amplitude group enables the operator to measure signal amplitude in units of either voltage or dBm.

3-19. OPERATING PRECAUTIONS

3-20. Signal Input

3-21. The HP 8558B Spectrum Analyzer plug-in is a sensitive measuring instrument. Overloading the input with too much power, peak voltage, or dc voltage will permanently damage the input circuits. Do not exceed the input levels specified below:

Maximum Input (Damage) Levels

HP 8558B

Total Power:

+ 30 dBm (1W, 7.1 Vrms)
Option 001: + 30 dBm (1W, 8.7 Vrms)
Option 002: + 80 dBmV (1.3W, 10 Vrms)

dc or ac (<100 Hz): ±50V

Peak Pulse Power: + 50 dBm (100W, >10 μ sec pulse width, 0.01% duty cycle) with \geq 20 dB input attenuation. *Option 002: + 100 dBmV (130W).*

NOTE

When you are measuring input signals of unknown power levels, a preliminary instrument setting of \geq 30 dB INPUT ATTEN is recommended.

CAUTION

Although the spectrum analyzer's reference level can be set for power levels up to + 60 dBm, the total input power must not exceed the absolute maximum limits listed above.

3-22. Line Power On

3-23. Before connecting the line power cord, make sure the proper line voltage and line fuse have been selected for the display mainframe. Failure to set the ac power input selector on the display mainframe to correspond with the level of the ac source voltage could cause damage to the instrument when the power cord is plugged in.

WARNING

The spectrum analyzer and any device connected to it must be connected to power line ground. Failure to ensure proper grounding could result in shock hazard to personnel or damage to the instrument.

3-24. **LINE** power is switched at the display mainframe front panel. A safety indicator lights when the ac power is on. **NEVER** remove a spectrum analyzer plug-in from the display mainframe without first switching the ac **LINE** power switch to OFF.

3-25. For optimum performance, you should allow the spectrum analyzer to warm up for at least 30 minutes before using it to make measurements.

3-26. FRONT-PANEL ADJUSTMENT PROCEDURE

3-27. The front-panel adjustment procedure adapts the HP 8558B Spectrum Analyzer plug-in to a particular display mainframe, and should be performed daily after instrument warm-up. The step-by-step adjustment is also an excellent way for new users to become acquainted with the various spectrum analyzer controls. Once the procedure is completed, the spectrum analyzer is calibrated for absolute amplitude and frequency measurements. Set the controls as shown in Table 3-1 before you start the adjustment procedure.

TABLE 3-1. ADJUSTMENT SETTINGS

Function	Setting
Spectrum Analyzer Plug-In	
INPUT ATTEN (dB)* (push knob to engage)	10 dB
REFERENCE LEVEL Option 002	0 dBm + 50 dBmV
REF LEVEL FINE	0 dBm
Amplitude Scale	LIN
FREQ SPAN/DIV	10 MHz (uncoupled)
RESOLUTION BW	1 MHz (uncoupled)
SWEEP TIME/DIV	AUTO
SWEEP TRIGGER	FREE RUN
START – CENTER	CENTER
TUNING	>60 MHz
BASELINE CLIPPER	OFF
VIDEO FILTER	OFF
*On older plug-ins, set OPTIMUM INPUT to – 30 dBm.	
HP 853A Spectrum Analyzer Display	
TRACE A	WRITE
TRACE B	STORE BLANK
DGTL AVG	OFF
INPUT – B→A	OFF
HP 180-Series Display Mainframe	
DISPLAY	INT
MAGNIFIER	X1
SCALE (180TR, 182T)	OFF
PERSISTENCE (181T/TR)	MIN
Display Mode (181T/TR)	WRITE

3-28. Display Adjustments – HP 853A Spectrum Analyzer Display

1. Switch LINE power OFF then ON while holding PLOT GRAT pushbutton down to activate the digital test routines. The “#0” that appears on the left side of the CRT means that digital test routine #0 is now activated.
2. Press and release the PLOT GRAT pushbutton four times to step to digital test routine #4, as indicated by the “#4” displayed on the left side of the CRT.

3. With an adjustment tool, adjust the FOCUS control as necessary to make the characters on the CRT as clear as possible.
4. Adjust the X POSN and Y POSN controls to align the square trace pattern with the outermost CRT graticule lines.
5. Momentarily press the PLOT GRAT and PLOT TRACE pushbuttons simultaneously to exit the digital test routines.

3-29. Display Adjustments – HP 180-Series Display Mainframe

1. With an adjustment tool, adjust the VERTICAL POSN control to place the CRT trace on a horizontal graticule line near the CRT center.
2. Reduce the INTENSITY and set the SWEEP TIME/DIV control to MAN. Use the MAN SWEEP knob to center the CRT dot.



Leaving a dot on the CRT for prolonged periods at high intensity can burn the phosphor.

3. Adjust the FOCUS and ASTIG controls for the smallest round dot possible.
4. Reset the SWEEP TIME/DIV control to AUTO and increase the INTENSITY for an optimum CRT trace. Adjust the HORIZONTAL POSITION control to center the CRT trace. If the horizontal deflection is not exactly 10 divisions, adjust the HORIZ GAIN control located on the rear panel of the spectrum analyzer plug-in.

NOTE

To adjust the HORIZ GAIN, you must switch the LINE power OFF, then remove the spectrum analyzer plug-in from the mainframe.

5. Adjust TRACE ALIGN so that the CRT trace is parallel to the horizontal graticule line.

3-30. Frequency and Amplitude Adjustments

1. Adjust VERTICAL POSN to align the CRT trace with the bottom graticule line.
2. Center the LO feedthrough (i.e., the "signal" at 0 MHz) on the CRT with the TUNING control, pressing the FREQUENCY CAL pushbutton two or three times to remove tuning hysteresis in the first LO (YIG oscillator).
3. Narrow the FREQ SPAN/DIV to 200 kHz, and press the FREQUENCY CAL pushbutton once more. Adjust the REF LEVEL FINE control as necessary to position the signal peak near the top CRT graticule line.
4. Center the LO feedthrough again, if necessary, and adjust the FREQUENCY ZERO to calibrate the FREQUENCY MHz readout at 00.0 MHz.
5. Set the FREQ SPAN/DIV control to 1 MHz and the REF LEVEL FINE control to 0. Adjust the TUNING control for a FREQUENCY MHz readout of approximately 280 MHz.
6. Press the 10 dB/DIV Amplitude Scale pushbutton, and set the REFERENCE LEVEL control to -20 dBm ($+30$ dBmV for Option 002 instruments).
7. Connect the 280 MHz CAL OUTPUT to the spectrum analyzer input. Center the signal on the CRT with the TUNING control, pressing the FREQUENCY CAL pushbutton two or three times. The FREQUENCY MHz readout will indicate $280 \text{ MHz} \pm 5 \text{ MHz}$.
8. Press the LIN Amplitude Scale pushbutton. Adjust the REF LEVEL FINE control to place the signal peak at the top CRT graticule line.
9. Press the 10 dB/DIV Amplitude Scale pushbutton. Adjust VERTICAL GAIN to place the signal peak at the top CRT graticule line.
10. Repeat steps 8 and 9 until the signal peak remains at the top CRT graticule line when the Amplitude Scale is alternated between 10 dB/DIV and LIN.
11. Set the REF LEVEL FINE control to 0, and the REFERENCE LEVEL control to -30 dBm ($+20$ dBmV for Option 002 instruments).
12. Press the LIN Amplitude Scale pushbutton and adjust REF LEVEL CAL to place the signal peak at the top CRT graticule line.

HP 853A SPECTRUM ANALYZER DISPLAY

REAR PANEL FEATURES

- 1 **Line Power Receptacle:** Three-conductor male receptacle for connecting ac power cable. Power plug retaining bracket, included with standard instrument, can be installed to prevent power cable disconnection when instrument is in transit. Power cable coils on special rear feet when not in use.
- 2 **FUSE:** Spring-loaded holder for cartridge-type primary power fuse.
- 3 **SELECTOR (VOLTS):** Adapts primary power transformer configuration to voltage of ac primary power source.
- 4 **ADDRESS:** Switch settings determine address of instrument to be used for communications via HP-IB. Address is set as sum of the switches, where $A5 = 16$, $A4 = 8$, $A3 = 4$, $A2 = 2$, and $A1 = 1$.
- 5 **HORIZ (SWEEP) OUTPUT:** BNC jack is a sweep output or sweep input, depending on the position of SWEEP switch on Interface Assembly A9. SWEEP switch on assembly A9 is factory set for sweep output (INT).

As a BNC output, HORIZ (SWEEP) OUTPUT provides horizontal sweep voltage from a 5K-ohm output impedance. The $-5V$ to $+5V$ output range corresponds to a full 10-division CRT horizontal deflection.

As a BNC input with a 20K-ohm input impedance, HORIZ (SWEEP) OUTPUT allows the CRT display to be swept by a $-5V$ to $+5V$ external horizontal sweep signal (approximately 30V/sec maximum sweep rate for digital display mode).

- 6 **VERTICAL (VIDEO) OUTPUT:** BNC output provides detected video signal from a 50-ohm output impedance. Typical 0–800 mV output range corresponds to full 8-division CRT vertical deflection.

- 7 **BLANK (PENLIFT) OUTPUT:** BNC output provides a $+15V$ penlift/blanking signal from a 10K-ohm output impedance when CRT trace is blanked. Otherwise, output is low at 0V (low impedance, 150 mA max.) for an unblanked trace.
- 8 **21.4 MHz IF OUTPUT:** BNC output provides 21.4 MHz IF signal (linearly related to spectrum RF input) from a 50-ohm output impedance. Spectrum analyzer RESOLUTION BW controls the output bandwidth. Spectrum analyzer INPUT ATTEN, REFERENCE LEVEL FINE, and the first six REFERENCE LEVEL positions control the output amplitude. Output level is approximately -10 dBm into 50 ohms with a signal displayed at Reference Level.
- 9 **HP-IB Connector:** Hewlett-Packard Interface Bus connection allows remote instrument operation and direct digital plotting of CRT display.

FRONT PANEL FEATURES

- 10 **TRACE A, B:** Selects CRT display mode for each of two independent digital trace memories.

CLEAR WRITE: Continuously updates trace memory with current input signal data and displays trace memory contents on CRT.

MAXHOLD: Updates trace memory with maximum input signal data and displays trace memory contents on CRT.

STORE VIEW: Current trace memory contents are preserved and displayed on CRT.

STORE BLANK: Current trace memory contents are preserved without being displayed on CRT.

ANALOG DISPLAY: CRT display switches to conventional analog display of current input signal when both STORE BLANK push buttons are depressed.

- 11 **DGTL AVG:** Activates digital filtering algorithm that averages trace data over successive sweeps. Digital averaging should be restarted after any change in spectrum analyzer control settings.

7 **BLANK (PENLIFT) OUTPUT:** BNC output provides a +15V penlift/blanking signal from a 10K-ohm output impedance when CRT trace is blanked. Otherwise, output is low at 0V (low impedance, 150 mA max.) for an unblanked trace.

8 **21.4 MHz IF OUTPUT:** BNC output provides 21.4 MHz IF signal (linearly related to spectrum RF input) from a 50-ohm output impedance. Spectrum analyzer RESOLUTION BW controls the output bandwidth. Spectrum analyzer INPUT ATTEN, REFERENCE LEVEL FINE, and the first six REFERENCE LEVEL positions control the output amplitude. Output level is approximately -10 dBm into 50 ohms with a signal displayed at Reference Level.

9 **HP-IB Connector:** Hewlett-Packard Interface Bus connection allows remote instrument operation and direct digital plotting of CRT display.

HP 853A SPECTRUM ANALYZER DISPLAY

REAR PANEL FEATURES

1 **Line Power Receptacle:** Three-conductor male receptacle for connecting ac power cable. Power plug retaining bracket, included with standard instrument, can be installed to prevent power cable disconnection when instrument is in transit. Power cable coils on special rear feet when not in use.

2 **FUSE:** Spring-loaded holder for cartridge-type primary power fuse.

3 **SELECTOR (VOLTS):** Adapts primary power transformer configuration to voltage of ac primary power source.

4 **ADDRESS:** Switch settings determine address of instrument to be used for communications via HP-IB. Address is set as sum of the switches, where A5 = 16, A4 = 8, A3 = 4, A2 = 2, and A1 = 1.

5 **HORIZ (SWEEP) OUTPUT:** BNC jack is a sweep output or sweep input, depending on the position of SWEEP switch on Interface Assembly A9. SWEEP switch on assembly A9 is factory set for sweep output (INT).

As a BNC output, HORIZ (SWEEP) OUTPUT provides horizontal sweep voltage from a 5K-ohm output impedance. The -5V to +5V output range corresponds to a full 10-division CRT horizontal deflection.

As a BNC input with a 20K-ohm input impedance, HORIZ (SWEEP) OUTPUT allows the CRT display to be swept by a -5V to +5V external horizontal sweep signal (approximately 30V/sec maximum sweep rate for digital display mode).

6 **VERTICAL (VIDEO) OUTPUT:** BNC output provides detected video signal from a 50-ohm output impedance. Typical 0-800 mV output range corresponds to full 8-division CRT vertical deflection.

12 **INPUT - B → A:** Subtracts contents of trace B memory point-by-point from current input signal data and stores result (normalized input signal data) in trace A memory. Reference line is factory-preset at center horizontal CRT graticule line; normalized trace appears at reference line when input signal data is identical to stored trace B. Reference line indicates 0 dB for relative amplitude measurements.

13 **PLOT GRAT/HP-IB CLEAR:** Initiates sequence of plotter commands over HP-IB to plot CRT graticule lines (and remotely-programmed annotation). Press push button again to abort active plot. HP-IB plotter must be set to listen-only mode.

To recover from illegal HP-IB commands (SYNTAX ERR) and to reset display state, press push button for at least 3 seconds to perform HP-IB CLEAR. Instrument returns to LOCAL and continues any HP-IB operation in progress.

Activate digital test routines by pressing PLOT GRAT push button while switching LINE power ON. Push button then selects desired test routine. Press both PLOT GRAT and PLOT TRACE push buttons to revert to normal display state.

14 **PLOT TRACE:** Initiates sequence of plotter commands over HP-IB to plot displayed CRT trace(s). Press push button again to abort active plot. HP-IB plotter must be set to listen-only mode.

15 **LINE:** AC line switch. Switches instrument primary power ON and OFF.

16 **INTENSITY:** Adjusts brightness of CRT trace(s) and annotation characters.

17 **SCALE:** Adjusts CRT background illumination. SCALE control is disabled in ANALOG DISPLAY mode.

18 **Y POSN:** Adjusts vertical position CRT trace. Use Y POSN with reference pattern in digital test routine #4 to align digital trace memory coordinates with corresponding CRT graticule lines.

19 **X POSN:** Adjusts horizontal position of CRT trace. Use X POSN with reference pattern in digital test routine #4 to align digital trace memory coordinates with corresponding CRT graticule lines.

20 **TRACE ALIGN:** Rotates trace about center of CRT.

21 **FOCUS:** Adjusts sharpness of CRT trace.

22 **CRT Annotation:** Indicates display control settings.

HP 8558B SPECTRUM ANALYZER PLUG-IN

23 **FREQUENCY MHz:** Displays spectrum analyzer center or start frequency.

24 **START-CENTER:** Selects mode of FREQUENCY MHz (23) readout.

25 **TUNING:** Adjusts spectrum analyzer start or center frequency. Coarse tuning is provided by large knob; smaller knob provides FINE tuning.

26 **VERTICAL POSN:** Adjusts vertical position of CRT trace.

27 **VERTICAL GAIN:** Adjusts deflection circuit gain for amplitude scale calibration of CRT display.

28 **FREQUENCY CAL:** Removes tuning hysteresis from first LO (YIG oscillator). FREQUENCY CAL should be pressed before calibration and whenever TUNING (25) is changed by more than 50 MHz.

29 **FREQUENCY ZERO:** Adjusts FREQUENCY MHz (23) readout for calibration on LO feedthrough (0 Hz).

30 **BASELINE CLIPPER:** Prevents CRT blooming in variable persistence, storage display mainframes (such as the HP 181T/TR) by blanking the lower portion of the CRT display. When it is operating in its digital display mode, the HP 853A Spectrum Analyzer Display does not respond to this control.

31 **VIDEO FILTER:** Post-detection low-pass filter smooths CRT trace by averaging random noise. The MAX (detent) position selects 1.5 Hz bandwidth for maximum noise averaging and noise level measurements. The VIDEO FILTER bandwidth is scaled by resolution bandwidth (36) setting. The MAX VIDEO FILTER should **not** be used for CW signal analysis.

32 **SWEEP Indicator:** Remains lit during each sweep.

36 RESOLUTION BW: Selects spectrum analyzer 3-dB bandwidth. Alignment of OPTIMUM markings (> <) automatically selects optimum resolution bandwidth for any frequency span. When pushed in, RESOLUTION BW couples mechanically with FREQ SPAN/DIV (35).

37 INPUT ATTEN: Selects desired RF input attenuation, indicated by blue numbers (push and turn).

38 REFERENCE LEVEL: Adjusts power level (in dBm or dBmV) represented by top CRT graticule line. Large outer knob adjusts REFERENCE LEVEL in calibrated 10-dB steps; FINE vernier provides 12 dB of continuous adjustment.

39 10 dB/DIV - 1 dB/DIV - LIN (Amplitude Scale): Selects CRT vertical axis amplitude calibration (logarithmic or linear scale). Reference Level remains constant at top CRT graticule line.

40 CAL OUTPUT: BNC (female) output provides calibration signal from 50-ohm output impedance. *Options 001 and 002: 75-ohm output impedance.*

CAUTION

50-ohm BNC connectors might cause damage if used directly with Option 001 and 002 75-ohm BNC INPUT and CAL OUTPUT connectors.

41 REF LEVEL CAL: Adjusts spectrum analyzer RF gain to calibrate top CRT graticule line for absolute amplitude measurements.

42 PROBE POWER: Provides power for high-impedance active probes, such as the HP 1121A.

43 INPUT 50Ω: Precision type N (female) signal input connector with 50-ohm input impedance. *Options 001 and 002: INPUT 75Ω - 75-ohm BNC (female) signal input connector.*

CAUTION

50-ohm BNC connectors might cause damage if used directly with Option 001 and 002 75-ohm BNC INPUT and CAL OUTPUT connectors.

44 1st LO OUTPUT: 50-ohm BNC output provides 2.05 - 3.55 GHz first LO signal at approximately +10 dBm. Terminate 1st LO OUTPUT with 50-ohm load when not in use.

TRIGGER: Selects sweep trigger mode. Sweep triggered on internal post-video waveform. One-half major vertical deflection (noise, AM signals) required to trigger sweep. VIDEO used with 0 (zero) frequency span domain analysis.

Sweep triggered at ac line frequency.

END: End of each sweep triggers sweep.

Single sweep triggered or reset by SWEEP TRIGGER clockwise dial.

SPAN/DIV: Selects time required to sweep horizontal division on CRT.

Automatically selects fastest allowed sweep time as a function of FREQ SPAN/DIV (35), RESOLUTION BW (36), and FILTER (31) settings to maintain amplitude calibration. AUTO operation with FREQ SPAN/DIV and RESOLUTION BW controls uncoupled.

SWEEP: Selects calibrated sweep time. SWEEP is used primarily with 0 (Zero) frequency span for time-domain analysis of waveforms. Display amplitude is not guaranteed for other frequencies.

Enables manual frequency scan SWEEP knob.

POSITION: Selects CRT horizontal axis position.

RESOLUTION: Selects desired frequency span. Resolution of OPTIMUM markings (> <) automatically selects optimum resolution bandwidth (36).

MODE: Spectrum analyzer operates in normally-tuned receiver, at frequency selected by FREQ SPAN/DIV, with video domain display of signal modulation.

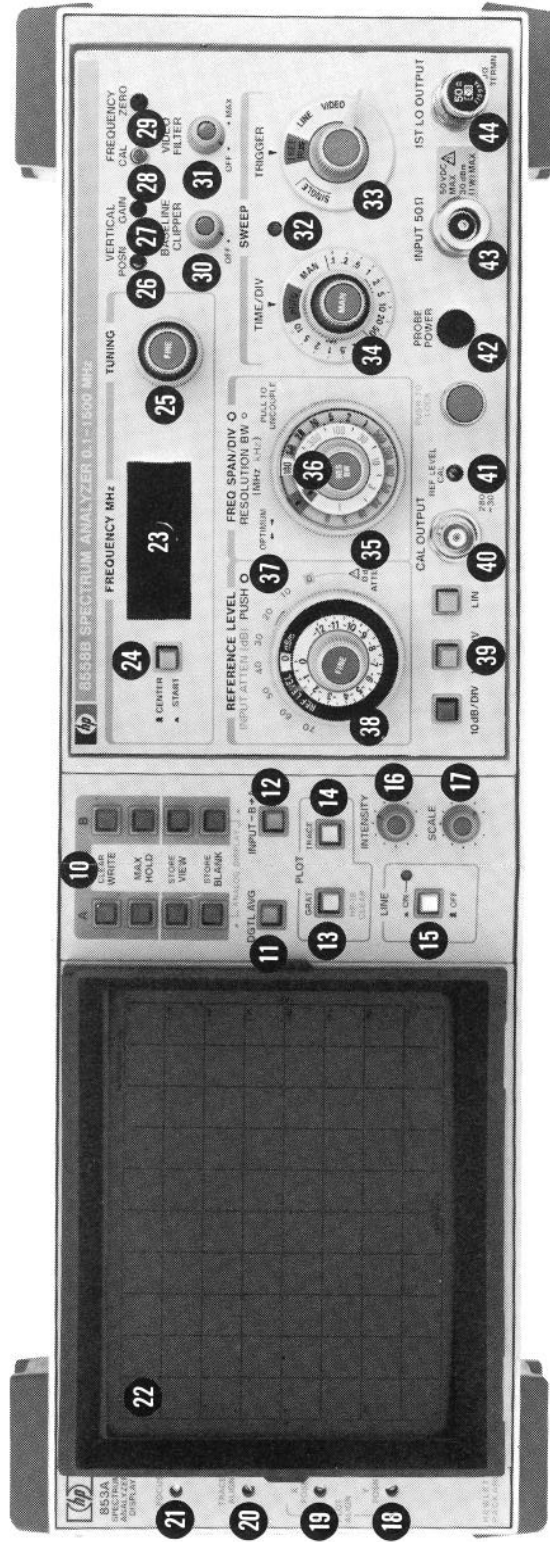
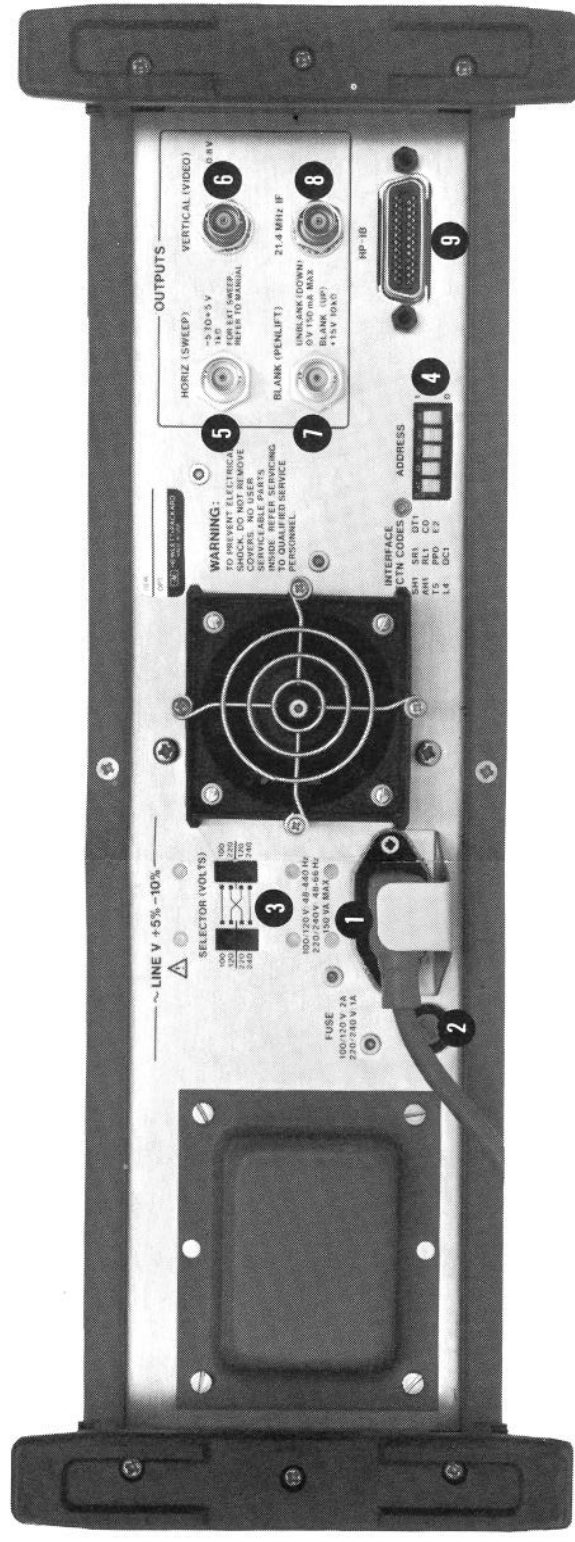

FIGURE 3-1. HP 8558B/855A CONTROLS, CONNECTORS, AND INDICATORS

SECTION IV PERFORMANCE TESTS

4-1. INTRODUCTION

4-2. The procedures in this section test the electrical performance of the instrument against the specifications in Section I. The performance tests included in this section are listed in Table 4-1. Most of the tests can be performed without access to the interior of the instrument. If a test measurement is marginal, perform the appropriate adjustment procedures in Section V.

TABLE 4-1. PERFORMANCE TESTS

Paragraph	Test
4-11	Frequency Span Accuracy
4-12	Tuning Accuracy
4-13	Residual FM
4-14	Noise Sidebands
4-15	Resolution Bandwidth Accuracy
4-16	Resolution Bandwidth Selectivity
4-17	Average Noise Level
4-18	Spurious Responses
4-19	Residual Responses
4-20	Frequency Response
4-21	Bandwidth Switching (Amplitude Variation)
4-22	Input Attenuator Accuracy
4-23	Reference Level Accuracy
4-24	Display Fidelity
4-25	Calibrator Accuracy

4-3. INSTRUMENTS TESTED

4-4. Since a 180-series Display mainframe is required for operation of the HP Model 8558B Spectrum Analyzer plug-in, the specifications listed in Table 1-1 apply when both instruments are functioning together. Consequently, the performance tests in this section verify the proper operation of both the HP 8558B and the 180-series Display mainframe.

4-5. EQUIPMENT REQUIRED

4-6. The equipment required for the performance tests is listed under Recommended Test Equipment in Section I. Any equipment that satisfies the critical specifications given in the table may be substituted for the recommended model.

4-7. TEST RECORD

4-8. Results of the performance tests may be tabulated in the Performance Test Record at the end of this section. The test record lists test specifications and acceptable limits.

4-9. CALIBRATION CYCLE

4-10. This instrument requires periodic calibration. Calibration should be verified every six months by means of the performance tests.

PERFORMANCE TESTS

NOTE

Perform the Front Panel Adjustment Procedure in Section III before proceeding with the performance tests. Allow at least 30 minutes warmup time.

4-11. FREQUENCY SPAN ACCURACY

SPECIFICATION

Fourteen calibrated spans from 100 MHz/div to 5 kHz/div in a 1, 2, 5 sequence. Frequency error between any two points on the display is less than $\pm 5\%$ of the indicated frequency separation.

DESCRIPTION

Wide span widths are checked by using the 100-, 10-, and 1-MHz outputs from a comb generator. Narrow span widths are checked by using the output from a comb generator modulated by a function generator. Since the comb generator produces frequency components separated by a precisely determined frequency interval, the resultant spectral lines displayed on the CRT are evenly spaced when no span error exists in the instrument. Thus, span error is the cumulative variance of distance among the spectral line intervals displayed across the CRT. The amount of span error is determined by comparing the distance of the first nine graticule divisions to the display distance of the corresponding spectral line intervals.

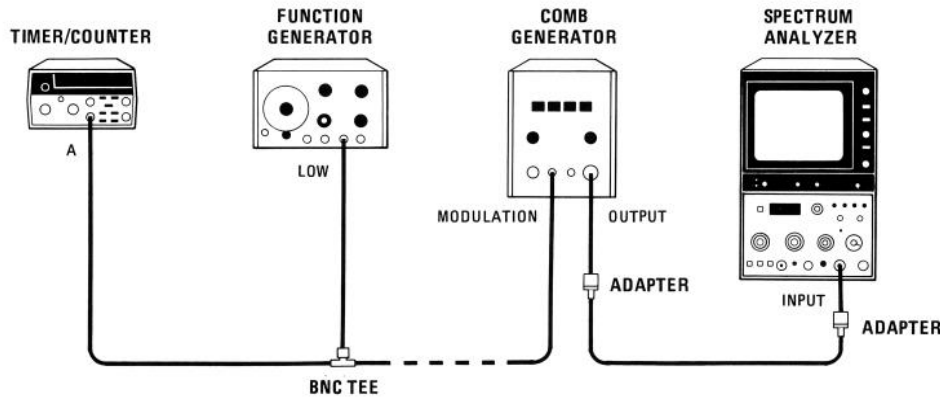

FIGURE 4-1. FREQUENCY SPAN ACCURACY TEST SETUP

EQUIPMENT

Comb Generator	HP 8406A
Timer/Counter	HP 5308A
Function Generator	HP 3310A
BNC Cable, 120 cm (48 in)	HP 10503A
Adapter, Type N (m) to BNC (f) (2 required)	HP 1250-0780
BNC Tee	HP 1250-0781

Additional Equipment, Options 001 and 002:

<i>Minimum Loss Adapter, 75Ω to 50Ω</i>	<i>HP 08558-60031</i>
<i>BNC Cable, 30 cm (12 in), 75Ω</i>	<i>HP 11652-60012</i>
<i>Adapter, SMA (f) to SMA (f)</i>	<i>HP 1250-1158</i>
<i>Adapter, BNC (f) to SMA (m)</i>	<i>HP 1250-1200</i>

PERFORMANCE TESTS

4-11. FREQUENCY SPAN ACCURACY (Cont'd)

PROCEDURE

1. Set equipment controls as follows:

Spectrum Analyzer:

START-CENTER CENTER
 TUNING 800 MHz
 FREQ SPAN/DIV 100 MHz
 RESOLUTION BW OPTIMUM, coupled (pushed in)
 INPUT ATTEN 0 dB
 REFERENCE LEVEL -20 dBm
 002: +30 dBmV
 Amplitude Scale 10 dB/DIV
 SWEEP TIME/DIV AUTO
 SWEEP TRIGGER FREE RUN
 BASELINE CLIPPER OFF
 VIDEO FILTER OFF

Comb Generator:

COMB FREQUENCY - MHz 100 MC
 INTERPOLATION AMPLITUDE - 1 MHz OFF
 OUTPUT AMPLITUDE 10 o'clock

Function Generator:

FUNCTION SINE
 RANGE 10K
 Frequency 200 kHz
 DC OFFSET LEVEL 0

2. Connect equipment as shown in Figure 4-1 but do not connect function generator to comb generator.
3. Adjust spectrum analyzer TUNING control to position one spectral line (from comb generator) at first graticule line (left-hand edge of display). Measure error between ninth spectral line and ninth graticule line as shown in Figure 4-2. Error should be no greater than ± 0.4 division.

_____div

4. Set FREQ SPAN/DIV to 50 MHz. Adjust TUNING control to position one spectral line at first graticule line. Measure error between fifth spectral line and ninth graticule line. Error should be no greater than ± 0.4 division.

_____div

PERFORMANCE TESTS

4-11. FREQUENCY SPAN ACCURACY (Cont'd)

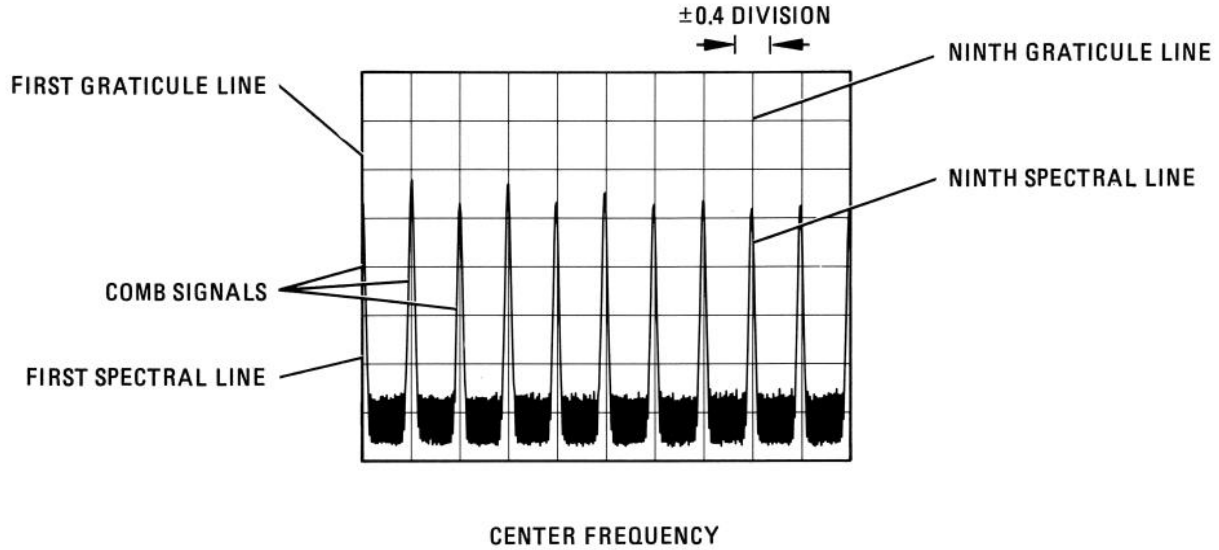

FIGURE 4-2. FREQUENCY SPAN ACCURACY MEASUREMENT FOR NINTH SPECTRAL LINE

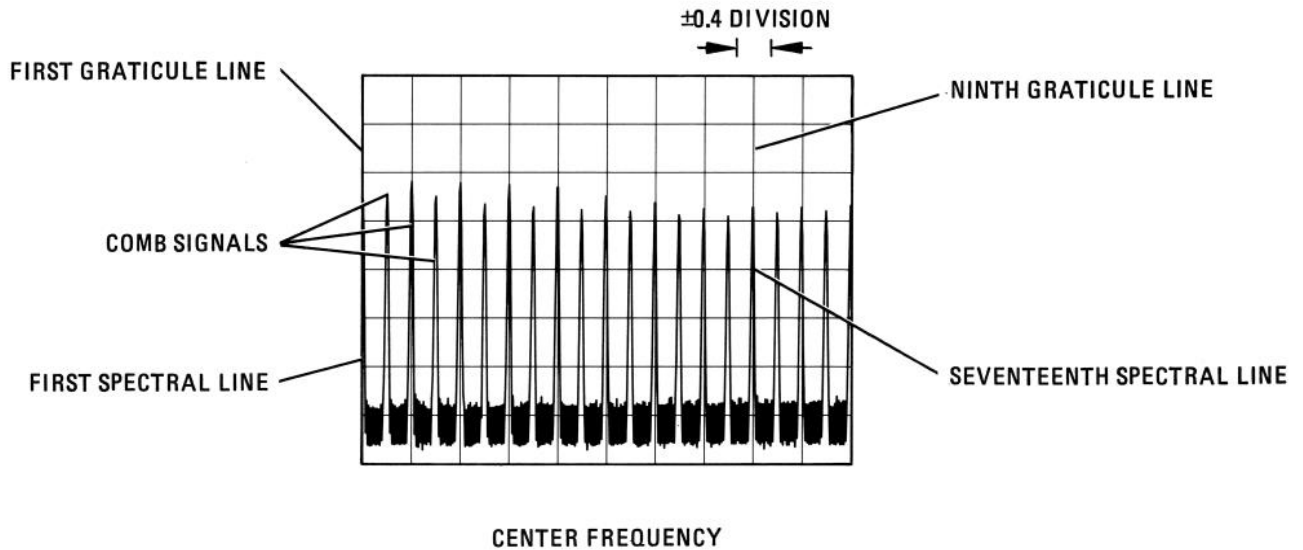

FIGURE 4-3. FREQUENCY SPAN ACCURACY MEASUREMENT FOR SEVENTEENTH SPECTRAL LINE

PERFORMANCE TESTS

4-11. FREQUENCY SPAN ACCURACY (Cont'd)

5. Set comb generator COMB FREQUENCY – MHz for 10-MHz comb. Set spectrum analyzer FREQ SPAN/DIV to 20 MHz. Adjust TUNING control to position one spectral line at first graticule line. Measure error between 17th spectral line and ninth graticule line as shown in Figure 4-3. Error should be no greater than ± 0.4 division.

_____div
 6. Set FREQ SPAN/DIV to 10 MHz. Adjust TUNING control to position one spectral line at first graticule line. Measure error between ninth spectral line and ninth graticule line. Error should be no greater than ± 0.4 division.

_____div
 7. Set FREQ SPAN/DIV to 5 MHz. Adjust TUNING control to position one spectral line at first graticule line. Measure error between fifth spectral line and ninth graticule line. Error should be no greater than ± 0.4 division.

_____div
 8. Set comb generator COMB FREQUENCY – MHz for 1-MHz comb. Set spectrum analyzer FREQ SPAN/DIV to 2 MHz. Adjust TUNING control to position one spectral line at first graticule line. Measure error between 17th spectral line and ninth graticule line. Error should be no greater than ± 0.4 division.

_____div
 9. Set FREQ SPAN/DIV to 1 MHz. Adjust TUNING control to position one spectral line at first graticule line. Measure error between ninth spectral line and ninth graticule line. Error should be no greater than ± 0.4 division.

_____div
 10. Set FREQ SPAN/DIV to 500 kHz. Adjust TUNING control to position one spectral line at first graticule line. Measure error between fifth spectral line and ninth graticule line. Error should be no greater than ± 0.4 division.

_____div
 11. Set comb generator COMB FREQUENCY – MHz for 10-MHz comb. Adjust spectrum analyzer TUNING to position a spectral line at center graticule line. Turn on comb generator INTERPOLATION AMPLITUDE – 1 MHz.
 12. Set function generator frequency to 200 kHz ($\pm 0.5\%$) using frequency counter. Connect function generator output to comb generator MODULATION input. Set function generator OUTPUT LEVEL for a clean 200-kHz comb on the spectrum analyzer display.
-

PERFORMANCE TESTS

4-11. FREQUENCY SPAN ACCURACY (Cont'd)

NOTE

To obtain a clean comb on the spectrum analyzer display, use the LOW or HIGH output of the function generator as necessary. Readjust the function generator OUTPUT LEVEL and the comb generator INTERPOLATION AMPLITUDE – 1 MHz as necessary.

13. Set spectrum analyzer FREQ SPAN/DIV to 200 kHz. Adjust TUNING control to position one spectral line at first graticule line. Measure error between ninth spectral line and ninth graticule line. Error should be no greater than ± 0.4 division.

_____div

14. Using procedure of NOTE in step 12, vary spectrum analyzer FREQ SPAN/DIV and Function Generator Output Frequency in accordance with Table 4-2. Adjust spectrum analyzer TUNING control to position one spectral line at first graticule line. Measure span error between ninth spectral line and ninth graticule line.

TABLE 4-2. NARROW SPAN WIDTH ERROR MEASUREMENT

Spectrum Analyzer		Function Generator Output Frequency*	Allowable Error (Max.)
FREQ SPAN/DIV	RESOLUTION BW		
100 kHz	OPTIMUM	100 kHz	± 0.4 Division
50 kHz	OPTIMUM	50 kHz	± 0.4 Division
20 kHz	OPTIMUM	20 kHz	± 0.4 Division
10 kHz	OPTIMUM	10 kHz	± 0.4 Division
5 kHz	OPTIMUM	5 kHz	± 0.4 Division

*Check function generator output frequency using a frequency counter. Frequency readout should be within $\pm 0.5\%$ of desired audio frequency.

PERFORMANCE TESTS

4-12. TUNING ACCURACY

SPECIFICATION

0 to 195 MHz: $\pm(1 \text{ MHz} \pm 20\% \text{ of FREQ SPAN/DIV setting})$, 10°C to 40°C

195 to 1500 MHz: $\pm(5 \text{ MHz} \pm 20\% \text{ of FREQ SPAN/DIV setting})$, 10°C to 40°C.

DESCRIPTION

A comb generator is used to provide 1-, 10-, or 100-MHz frequency components that produce spectral lines on the CRT at 1-, 10-, or 100-MHz intervals, respectively. The spectrum analyzer TUNING control is adjusted until the desired test frequency is shown on the FREQUENCY MHz readout of the Digital Panel Meter. The FREQUENCY CAL switch is pressed and the amount of readout (or tuning) error is found by measuring the distance of the spectral line offset from the center graticule line.

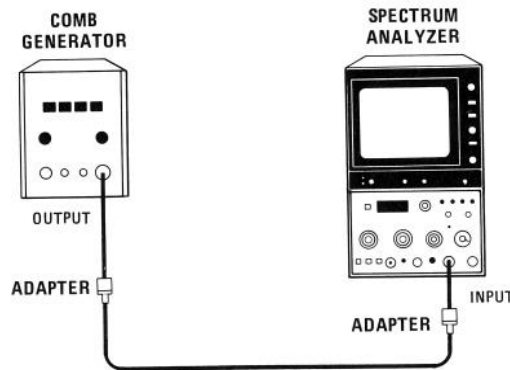

FIGURE 4-4. TUNING ACCURACY TEST SETUP

EQUIPMENT

Comb Generator	HP 8406A
BNC Cable, 120 cm (48 in)	HP 10503A
Adapter, Type N (m) to BNC (f) (2 required)	HP 1250-0780

Additional Equipment, Options 001 and 002:

<i>Minimum Loss Adapter, 75Ω to 50Ω</i>	<i>HP 08558-60031</i>
<i>BNC Cable, 30 cm (12 in), 75Ω</i>	<i>HP 11652-60012</i>
<i>Adapter, SMA (f) to SMA (f)</i>	<i>HP 1250-1158</i>
<i>Adapter, BNC (f) to SMA (m)</i>	<i>HP 1250-1200</i>

PERFORMANCE TESTS

4-12. TUNING ACCURACY (Cont'd)

PROCEDURE

1. Set spectrum analyzer controls as follows:

START-CENTER	CENTER
FREQ SPAN/DIV	200 kHz
RESOLUTION BW	OPTIMUM
INPUT ATTEN	0 dB
REFERENCE LEVEL	-20 dBm
<i>002: +30 dBmV</i>	
Amplitude Scale	10 dB/DIV
SWEEP TIME/DIV	AUTO
SWEEP TRIGGER	FREE RUN
BASELINE CLIPPER	OFF
VIDEO FILTER	OFF

2. Adjust spectrum analyzer TUNING control to position LO feedthrough signal at center graticule line of display. Press FREQUENCY CAL switch and reposition LO feedthrough signal at center graticule line, as required. Adjust FREQ ZERO control for zero indication on FREQUENCY MHz readout. LO feedthrough signal should still be positioned at center graticule line of display.
3. Connect equipment as shown in Figure 4-4.
4. Set comb generator controls as follows:

COMB FREQUENCY – MHz	10 MC
INTERPOLATION AMPLITUDE – 1 MHz	OFF
OUTPUT AMPLITUDE	10 o'clock

5. Adjust spectrum analyzer TUNING control until FREQUENCY MHz readout indicates 10.0 MHz. Press FREQUENCY CAL switch. Comb generator spectral line, displayed on CRT, should be within 5.2 divisions (± 1.04 MHz) of center graticule line.

_____div

NOTE

If the spectral line is off screen, set FREQ SPAN/DIV to 500 kHz and check that the spectral line is within 2.2 divisions of the center graticule line.

6. Using procedure of step 5, adjust spectrum analyzer and comb generator controls as shown in Table 4-3 to measure TUNING accuracy. After tuning to each FREQUENCY MHz readout, press FREQUENCY CAL switch before measuring TUNING accuracy.

PERFORMANCE TESTS

4-12. TUNING ACCURACY (Cont'd)

TABLE 4-3. TUNING ACCURACY MEASUREMENT

Spectrum Analyzer		Comb Generator	Specification (Spectral line limits referenced to center graticule line) (Divisions)	
FREQUENCY MHz Readout (MHz)	FREQ SPAN/DIV Setting	COMB FREQUENCY—MC Setting (MHz)		
			Min.	Max.
20.0	200 kHz	10	-5.2	+5.2
40.0	200 kHz	10	-5.2	+5.2
60.0	200 kHz	10	-5.2	+5.2
80.0	200 kHz	10	-5.2	+5.2
100.0	200 kHz	10	-5.2	+5.2
120.0	200 kHz	10	-5.2	+5.2
140.0	200 kHz	10	-5.2	+5.2
160.0	200 kHz	10	-5.2	+5.2
180.0	200 kHz	10	-5.2	+5.2
200	1 MHz	100	-5.2	+5.2
400	1 MHz	100	-5.2	+5.2
600	1 MHz	100	-5.2	+5.2
800	1 MHz	100	-5.2	+5.2
1000	1 MHz	100	-5.2	+5.2
1200	1 MHz	100	-5.2	+5.2
1400	1 MHz	100	-5.2	+5.2
1500	1 MHz	100	-5.2	+5.2

PERFORMANCE TESTS

4-13. RESIDUAL FM

SPECIFICATION

Less than 1 kHz peak-to-peak for time ≤ 0.1 second

FM DESCRIPTION

This test measures the inherent short-term instability (residual FM) of the LO system in the spectrum analyzer. A stable signal applied to the input of the spectrum analyzer is slope-detected on the linear portion of the 10 kHz bandwidth filter in zero span (fixed-tuned receiver). (See Figure 4-6a.) Instability in the LO system is transferred to the IF signal in the mixing process. As the IF signal moves in relation to the center of the IF filter, the attenuation of the signal changes in accordance with the skirt characteristics of the filter. If the signal stays on the linear portion of the IF filter skirt, the amplitude of the IF signal applied to the final detector (and thus the level on the display) is linearly related to the frequency of the IF signal. (See Figure 4-6b). Therefore, any variations in level seen on the display are linearly related to variations in LO frequency.

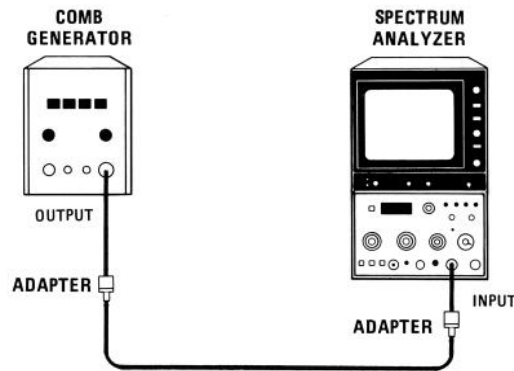

FIGURE 4-5. RESIDUAL FM TEST SETUP

EQUIPMENT

Comb Generator	HP8406A
BNC Cable, 120 cm (48 in)	HP 10503A
Adapter, Type N (m) to BNC (f) (2 required)	HP 1250-0780

Additional Equipment, Options 001 and 002:

<i>Minimum Loss Adapter, 75Ω to 50Ω</i>	<i>HP 08558-60031</i>
<i>BNC Cable, 30 cm (12 in), 75Ω</i>	<i>HP 11652-60012</i>
<i>Adapter, SMA (f) to SMA (f)</i>	<i>HP 1250-1158</i>
<i>Adapter, BNC (f) to SMA (m)</i>	<i>HP 1250-1200</i>

PERFORMANCE TESTS

4-13. RESIDUAL FM (Cont'd)

a. Residual FM in Zero Span

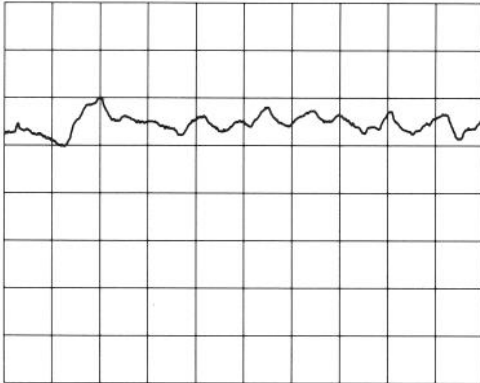

b. Shape of 10 kHz Resolution BW Filter

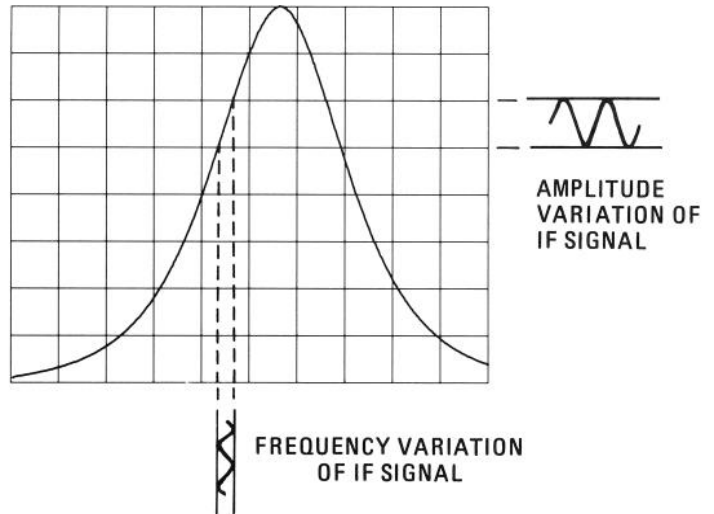

FIGURE 4-6. EXAMPLE OF RESIDUAL FM

PROCEDURE

1. Set spectrum analyzer and comb generator controls as follows:

Spectrum Analyzer:

START-CENTER	CENTER
FREQUENCY SPAN/DIV.....	100 kHz
RESOLUTION BW	10 kHz
INPUT ATTEN	0 dB
REFERENCE LEVEL	-20 dBm
<i>002: +30 dBmV</i>	
Amplitude Scale	LIN
SWEEP TIME/DIV	AUTO
SWEEP TRIGGER.....	FREE RUN
BASELINE CLIPPER	OFF
VIDEO FILTER.....	OFF

Comb Generator:

COMB FREQUENCY - MHz.....	100 MC
INTERPOLATION AMPLITUDE - 1 MHz	OFF
OUTPUT AMPLITUDE	Fully clockwise

PERFORMANCE TESTS

4-13. RESIDUAL FM (Cont'd)

2. Connect OUTPUT of comb generator to spectrum analyzer INPUT connector as shown in Figure 4-5.

NOTE

The HP 8558B is sensitive to vibration. Be sure the instrument is in a vibration-free environment.

3. Adjust spectrum analyzer TUNING control to display 500-MHz signal produced by comb generator. Adjust REFERENCE LEVEL and REF LEVEL FINE controls to position peak of signal at top graticule line.
4. Keep 500-MHz signal centered on CRT while reducing FREQ SPAN/DIV to zero.
5. Set RESOLUTION BW to 10 kHz and SWEEP TIME/DIV to .1 SEC.
6. Slightly readjust fine TUNING control of spectrum analyzer until trace appears between fourth and seventh graticule lines. Peak-to-peak variation of trace should not exceed one major vertical division for each major horizontal division. (See Figure 4-6a.)

_____div

PERFORMANCE TESTS

4-14. NOISE SIDEBANDS

SPECIFICATION

More than 65 dB below CW signal, 50 kHz or more away from signal with a 1-kHz resolution bandwidth and full video filtering.

DESCRIPTION

A stable 400-MHz CW signal is applied at a -20 dBm level to the spectrum analyzer and is displayed on the CRT. The test is designed to measure the amplitude of noise-associated sidebands and unwanted responses.

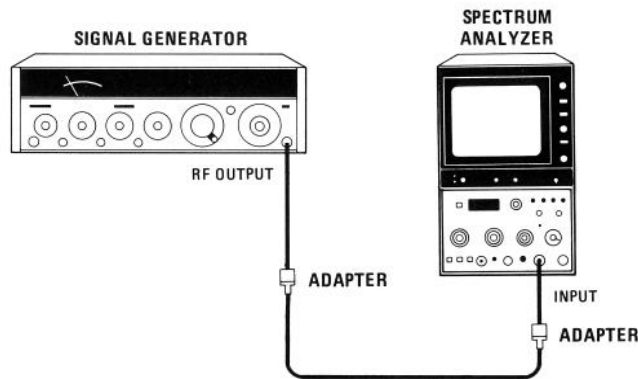

FIGURE 4-7. NOISE SIDEBAND TEST SETUP

EQUIPMENT

Signal Generator	HP 8640B
BNC Cable, 120 cm (48 in)	HP 10503A
Adapter, Type N (m) to BNC (f) (2 required)	HP 1250-0780

Additional Equipment, Options 001 and 002:

<i>Minimum Loss Adapter, 75Ω to 50Ω</i>	<i>HP 08558-60031</i>
<i>BNC Cable, 30 cm (12 in), 75Ω</i>	<i>HP 11652-60012</i>
<i>Adapter, SMA (f) to SMA (f)</i>	<i>HP 1250-1158</i>
<i>Adapter, BNC (f) to SMA (m)</i>	<i>HP 1250-1200</i>

PERFORMANCE TESTS

4-14. NOISE SIDEBANDS (Cont'd)

PROCEDURE

1. Set equipment controls as follows:

Spectrum Analyzer

START-CENTER	CENTER
TUNING.....	400 MHz
FREQ SPAN/DIV	1 MHz
RESOLUTION BW	30 KHz
INPUT ATTEN	10 dB
REFERENCE LEVEL	- 20 dBm
<i>002: +30 dBmV</i>	
Amplitude Scale	10 dB/DIV
SWEEP TIME/DIV	AUTO
SWEEP TRIGGER.....	FREE RUN
BASELINE CLIPPER	OFF
VIDEO FILTER.....	OFF

Signal Generator

FREQUENCY.....	400 MHz
RF OUTPUT	- 20 dBm
RF	ON
AM.....	OFF
FM.....	OFF

2. Connect equipment as shown in Figure 4-7.
3. Adjust TUNING control to locate 400-MHz signal on CRT.
4. Adjust REFERENCE LEVEL and REF LEVEL FINE controls to position peak of 400-MHz signal at top graticule line.
5. Decrease FREQ SPAN/DIV to 20 kHz and RESOLUTION BW to 1 kHz. Adjust TUNING to keep signal centered.
6. Position signal at center of display. Turn VIDEO FILTER control fully clockwise (not in detent). Measure noise sidebands existing more than 2.5 division (50 kHz) from 400-MHz signal. Noise sidebands should be greater than 65 dB (6.5 divisions) down from top graticule line.

_____div down

PERFORMANCE TESTS

4-15. RESOLUTION BANDWIDTH ACCURACY

SPECIFICATION

Individual resolution bandwidth 3-dB points calibrated to ± 20% (10°C to 40°C)

DESCRIPTION

Resolution bandwidth accuracy is measured in the linear mode to eliminate log amplifier errors. Since signal level at the 3-dB points (half-power points) is related to peak signal level by a voltage ratio of 0.707:1.0, a peak level of 7.1 vertical divisions on the spectrum analyzer display gives a half-power level of 5 vertical divisions:

$$0.707 \text{ (voltage ratio)} = X \text{ div}/7.1 \text{ div}$$

$$X \text{ div} = (7.1)(0.707)$$

$$\approx 5 \text{ div}$$

In the 30-, 10-, and 1-kHz bandwidths, a 301.4-MHz signal (second IF) is injected into A9 Third Converter Assembly to provide the stability required for measurement of narrow resolution bandwidths.

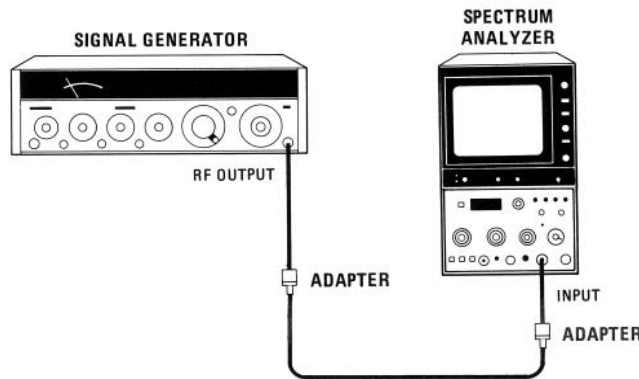

FIGURE 4-8. RESOLUTION BANDWIDTH ACCURACY TEST SETUP, 3 MHz TO 100 kHz

EQUIPMENT

Signal Generator	HP 8640B
Extender Cable Assembly	HP 5060-0303
Adapter, SMC (m) to BNC (m)	HP 1250-0831
Adapter, BNC (f) to BNC (f)	HP 1250-0080
Adapter, Type N (m) to BNC (f) (2 required)	HP 1250-0780
BNC Cable, 120 cm (48 in)	HP 10503A

Additional Equipment, Options 001 and 002:

<i>Minimum Loss Adapter, 75Ω to 50Ω</i>	<i>HP 08558-60031</i>
<i>BNC Cable, 30 cm (12 in), 75Ω</i>	<i>HP 11652-60012</i>
<i>Adapter, SMA (f) to SMA (f)</i>	<i>HP 1250-1158</i>
<i>Adapter, BNC (f) to SMA (m)</i>	<i>HP 1250-1200</i>

PERFORMANCE TESTS

4-15. RESOLUTION BANDWIDTH ACCURACY (Cont'd)

PROCEDURE

WARNING

This test must be performed with power supplied to the instrument and with protective covers removed. The test should be performed only by service-trained personnel who are aware of the hazards involved.

1. Set equipment controls as follows:

Spectrum Analyzer:

START-CENTER	CENTER
TUNING	10 MHz
FREQ SPAN/DIV	0
RESOLUTION BW	3 MHz
INPUT ATTEN	20 dB
REFERENCE LEVEL	0 dBm
<i>002: +50 dBmV</i>	
Amplitude Scale	LIN
SWEEP TIME/DIV	5 mSEC
SWEEP TRIGGER	FREE RUN
BASELINE CLIPPER	OFF
VIDEO FILTER	OFF

Signal Generator:

COUNTER MODE	INT, EXPAND X10
AM	OFF
FM	OFF
FREQUENCY TUNE	10 MHz
RF	ON
OUTPUT LEVEL	0 dBm

2. Connect equipment as shown in Figure 4-8.
3. Adjust spectrum analyzer TUNING control to locate peak of 10-MHz signal on CRT. Reduce signal generator output if necessary.
4. Adjust signal generator OUTPUT LEVEL to position trace at 7.1 divisions above graticule baseline.
5. Tune signal generator frequency until trace drops to 5 divisions above graticule baseline. Record signal generator frequency.

_____MHz

PERFORMANCE TESTS

4-15. RESOLUTION BANDWIDTH ACCURACY (Cont'd)

- Tune signal generator frequency in direction opposite to that of step 5 until trace peaks (7.1 divisions above graticule baseline) and then drops to 5 divisions above graticule baseline. Record signal generator frequency.

_____MHz

- Calculate and record resolution bandwidth at 3-dB points (difference between frequencies recorded in steps 5 and 6).

Min.	Actual	Max.
2.40 MHz	_____	3.60 MHz

- Set RESOLUTION BW to 1 MHz, leaving FREQ SPAN/DIV set to 0. Set signal generator to 10 MHz and repeat steps 3 through 7.

Min.	Actual	Max.
800 kHz	_____	1200 kHz

- Set RESOLUTION BW to 300 kHz, leaving FREQ SPAN/DIV set to 0. Set signal generator to 10 MHz and repeat steps 3 through 7.

Min.	Actual	Max.
240 kHz	_____	360 kHz

- Set RESOLUTION BW to 100 kHz, leaving FREQ SPAN/DIV set to 0. Set signal generator to 10 MHz and repeat steps 3 through 7.

Min.	Actual	Max.
80 kHz	_____	120 kHz

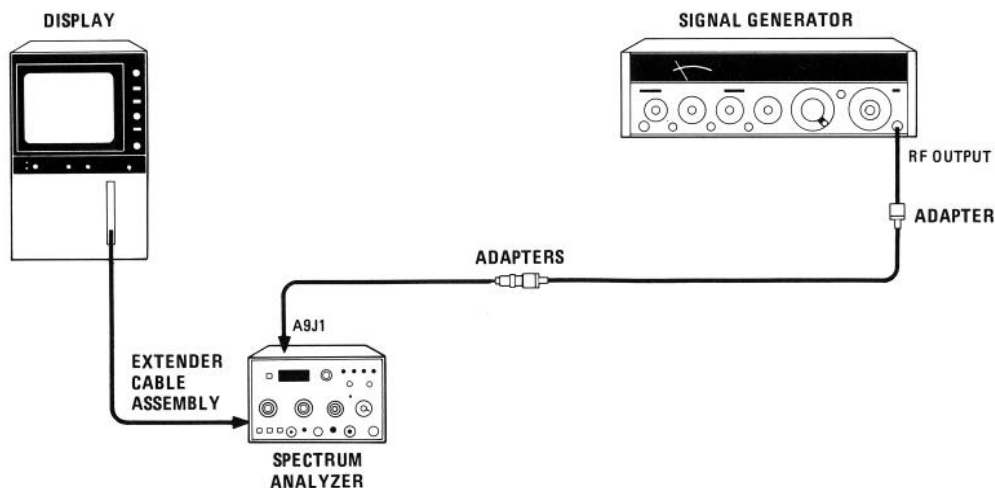

FIGURE 4-9. RESOLUTION BANDWIDTH ACCURACY TEST SETUP, 1 kHz TO 30 kHz

PERFORMANCE TESTS

4-15. RESOLUTION BANDWIDTH ACCURACY (Cont'd)

WARNING

In the following procedure, the plug-in must be removed from the display mainframe and connected through the extender cable assembly. Be very careful; the energy at some points in the instrument might, if contacted, cause personal injury. This test should be performed only by a skilled person who knows the hazard involved.

- 11. Set signal generator OUTPUT LEVEL to approximately -12 dBm and tune frequency to 301.4 MHz. Set COUNTER MODE to EXPAND X100.
- 12. Set spectrum analyzer INPUT ATTEN to 0 dB and REFERENCE LEVEL to -10 dBm. Set RESOLUTION BW to 30 kHz. Leave FREQ SPAN/DIV set to 0.

002: REFERENCE LEVEL, +40 dBmV.

- 13. Connect equipment as shown in Figure 4-9. Remove W7P1 from A10J2. Connect signal generator through adapters to W7P1.
- 14. Adjust signal generator frequency until spectrum analyzer trace is at peak. Set signal generator OUTPUT LEVEL to position trace at 7.1 divisions above graticule baseline.
- 15. Tune signal generator frequency until trace drops to 5 divisions above graticule baseline. Record signal generator frequency.

_____MHz

- 16. Tune signal generator frequency in direction opposite to that of step 15 until trace peaks and then drops to 5 divisions above graticule baseline. Record signal generator frequency.

_____MHz

- 17. Calculate and record resolution bandwidth at 3-dB points (difference between frequencies recorded in steps 15 and 16).

Min.	Actual	Max.
24 kHz	_____	36 kHz

- 18. Set RESOLUTION BW to 10 kHz, leaving FREQ SPAN/DIV set to 0. Repeat steps 14 through 17.

Min.	Actual	Max.
8 kHz	_____	12 kHz

PERFORMANCE TESTS

4-15. RESOLUTION BANDWIDTH ACCURACY (Cont'd)

19. Set RESOLUTION BW to 3 kHz, leaving FREQ SPAN/DIV set to 0. Repeat steps 14 through 17.

Min.	Actual	Max.
2.4 kHz	_____	3.6 kHz

20. Set RESOLUTION BW to 1 kHz, leaving FREQ SPAN/DIV set to 0. Repeat steps 14 through 17.

Min.	Actual	Max.
0.8 kHz	_____	1.2 kHz

21. Reconnect W7P1 to A10J2 unless continuing on with next performance test.

PERFORMANCE TESTS

4-16. RESOLUTION BANDWIDTH SELECTIVITY

SPECIFICATION

60-dB:3-dB resolution bandwidth ratio < 15:1.

DESCRIPTION

The 60-dB bandwidth is measured for all resolution bandwidths. The 60- to 3-dB resolution bandwidth ratio (shape factor) is then computed for each bandwidth by dividing the 3-dB value (from the Resolution Bandwidth Accuracy test) into the 60-dB value.

In the 30-, 10-, and 1-kHz bandwidths, a 301.4-MHz signal (second IF) is injected into A9 Third Converter assembly to provide the stability required for the measurement of narrow resolution bandwidths.

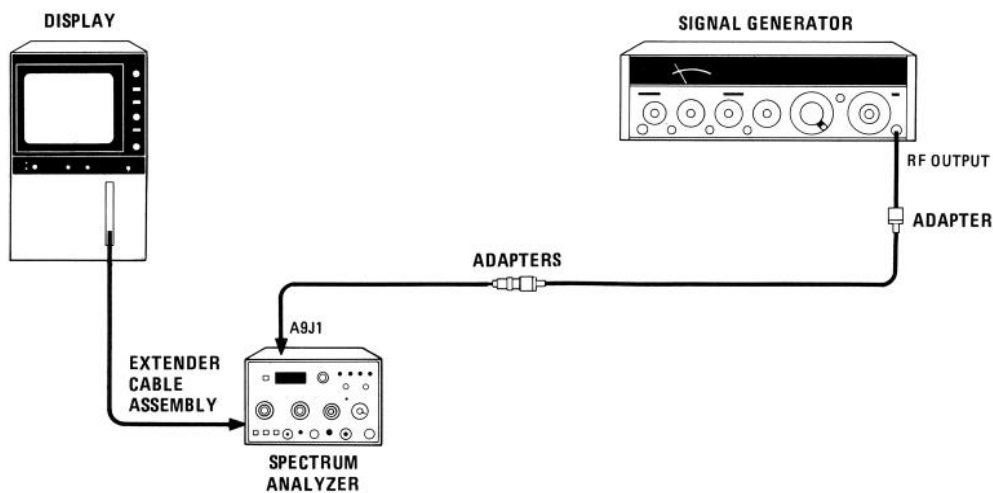

FIGURE 4-10. RESOLUTION BANDWIDTH SELECTIVITY TEST SETUP, 1 kHz TO 30 kHz

WARNING

In the following procedure, the plug-in must be removed from the display mainframe and connected through the extender cable assembly. Be very careful; the energy at some points in the instrument might, if contacted, cause personal injury. This test should be performed only by a skilled person who knows the hazard involved.

PERFORMANCE TESTS

4-16. RESOLUTION BANDWIDTH SELECTIVITY (Cont'd)

EQUIPMENT

Signal Generator	HP 8640B
Extender Cable Assembly	HP 5060-0303
Adapter, SMC (m) to BNC (m)	HP 1250-0831
Adapter, BNC (f) to BNC (f)	HP 1250-0080
Adapter, Type N (m) to BNC (f) (2 required)	HP 1250-0780
BNC Cable, 120 cm (48 in).....	HP 10503A

Additional Equipment, Options 001 and 002:

<i>Minimum Loss Adapter, 75Ω to 50Ω</i>	<i>HP 08558-60031</i>
<i>BNC Cable, 30 cm (12 in), 75Ω</i>	<i>HP 11652-60012</i>
<i>Adapter, SMA (f) to SMA (f)</i>	<i>HP 1250-1158</i>
<i>Adapter, BNC (f) to SMA (m)</i>	<i>HP 1250-1200</i>

PROCEDURE

1. Set equipment controls as follows:

Spectrum Analyzer

START-CENTER	CENTER
TUNING.....	50 MHz
FREQ SPAN/DIV.....	0
RESOLUTION BW	1 kHz
INPUT ATTEN	0 dB
REFERENCE LEVEL	- 10 dBm
002: +40 dBmV	
Amplitude Scale	10 dB/DIV
SWEEP TIME/DIV	5 mSEC
SWEEP TRIGGER.....	FREE RUN
BASELINE CLIPPER	OFF
VIDEO FILTER.....	OFF

Signal Generator

COUNTER MODE	INT, EXPAND X10
AM.....	OFF
FM.....	OFF
FREQUENCY TUNE	301.4 MHz
RF	ON
OUTPUT LEVEL	- 20 dBm

2. Connect equipment as shown in Figure 4-10. Remove W7P1 from A10J2. Connect signal generator through adapters to W7P1.
3. Adjust signal generator frequency until spectrum analyzer trace is at peak. Set signal generator OUTPUT LEVEL to position trace at top graticule line.

PERFORMANCE TESTS

4-16. RESOLUTION BANDWIDTH SELECTIVITY (Cont'd)

4. Tune signal generator until trace drops to 2 divisions above graticule baseline. Record signal generator frequency.
_____MHz
 5. Tune signal generator in direction opposite to that of step 4 until trace peaks and then drops to 2 divisions above graticule baseline. Record signal generator frequency.
_____MHz
 6. Calculate and record resolution bandwidth at 60-dB points (difference between frequencies recorded in steps 4 and 5).
_____kHz
 7. Set RESOLUTION BW to 3 kHz, leaving FREQ SPAN/DIV set to 0. Repeat steps 3 through 6.
_____kHz
 8. Set RESOLUTION BW to 10 kHz, leaving FREQ SPAN/DIV set to 0. Repeat steps 3 through 6.
_____kHz
 9. Set spectrum analyzer RESOLUTION BW to 30 kHz, leaving FREQ SPAN/DIV set to 0. Repeat steps 3 through 6.
_____kHz
 10. Reconnect W7P1 to A10J2. Set display LINE power to OFF and remove extender cable assembly. Install plug-in in mainframe and set LINE power to ON.
 11. Set signal generator OUTPUT LEVEL to 0 dBm.
 12. Set spectrum analyzer INPUT ATTEN to 20 dB and REFERENCE LEVEL to 0 dBm. Set RESOLUTION BW to 100 kHz, leaving FREQ SPAN/DIV set to 0.

002: REFERENCE LEVEL, +50 dBmV.
 13. Connect equipment as shown in Figure 4-11.
 14. Set signal generator frequency to 50 MHz. Adjust spectrum analyzer TUNING to locate peak of 50-MHz signal on CRT.
 15. Adjust signal generator OUTPUT LEVEL to position trace at top graticule line.
-

PERFORMANCE TESTS

4-16. RESOLUTION BANDWIDTH SELECTIVITY (Cont'd)

FIGURE 4-11. RESOLUTION BANDWIDTH SELECTIVITY TEST SETUP, 100 kHz TO 3 MHz

16. Tune signal generator frequency until trace drops to 2 divisions above graticule baseline. Record signal generator frequency.
_____MHz
17. Tune signal generator frequency in direction opposite to that of step 16 until trace peaks and then drops to 2 divisions above graticule baseline. Record signal generator frequency.
_____MHz
18. Calculate and record resolution bandwidth at 60-dB points (difference between frequencies recorded in steps 16 and 17).
_____kHz
19. Set spectrum analyzer RESOLUTION BW to 300 kHz, leaving FREQ SPAN/DIV set to 0. Repeat steps 14 through 18.
_____kHz
20. Set RESOLUTION BW to 1 MHz, leaving FREQ SPAN/DIV set to 0. Repeat steps 14 through 18.
_____MHz
21. Set RESOLUTION BW to 3 MHz, leaving FREQ SPAN/DIV set to 0. Repeat steps 14 through 18.
_____MHz
22. In Table 4-4, record 3-dB bandwidths computed in Resolution Bandwidth Accuracy test.
23. In Table 4-4, record 60-dB bandwidths recorded in this procedure.
24. For each resolution bandwidth, divide 60-dB bandwidth by 3-dB bandwidth to obtain Resolution Bandwidth Ratio. Each ratio should be less than 15:1.

PERFORMANCE TESTS

4-16. RESOLUTION BANDWIDTH SELECTIVITY (Cont'd)

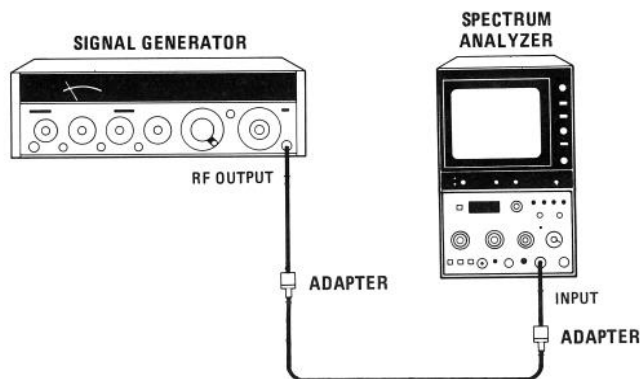
TABLE 4-4. RESOLUTION BW SELECTIVITY

RESOLUTION BW Setting	MEASURED 3 dB BW	MEASURED 60 dB BW	Resolution Bandwidth Ratio (60 dB BW): (3 dB BW)
3 MHz	_____	_____	_____
1 MHz	_____	_____	_____
300 kHz	_____	_____	_____
100 kHz	_____	_____	_____
30 kHz	_____	_____	_____
10 kHz	_____	_____	_____
3 kHz	_____	_____	_____
1 kHz	_____	_____	_____

PERFORMANCE TESTS

4-17. AVERAGE NOISE LEVEL

SPECIFICATION

Less than -107 dBm with a 10-kHz resolution bandwidth (0 dB input attenuation), 1 MHz to 1500 MHz.

001: *Less than -100 dBm*

002: *Less than -53 dBmV*

DESCRIPTION

The average noise level is checked by observing the average noise power level displayed on the CRT when no input signal is applied to the instrument. The test is performed with a 10-kHz resolution bandwidth.

PROCEDURE

1. Set spectrum analyzer controls as follows:

START-CENTER	CENTER
TUNING	500 MHz
FREQ SPAN/DIV	100 MHz
RESOLUTION BW	10 kHz
INPUT ATTEN	0 dB
REFERENCE LEVEL	-60 dBm
002: <i>-10 dBmV</i>	
Amplitude Scale	10 dB/DIV
SWEEP TIME/DIV	10 mSEC
SWEEP TRIGGER	FREE RUN
BASELINE CLIPPER	OFF
VIDEO FILTER	12 o'clock

2. Adjust TUNING until LO feedthrough is not on screen. Set VIDEO FILTER to MAX (not in detent) and observe CRT display of noise level from 1 MHz to 1000 MHz. Noise level, as shown in Figure 4-12, should be less than -107 .

001: *Change " -107 dBm" to " -100 dBm" throughout procedure and in Figure 4-12.*

002: *Change " -107 dBm" to " -53 dBmV" throughout procedure and in Figure 4-12.*

_____ < -107 dBm

3. Set START-CENTER switch to START. Observe average noise level from 500 MHz to 1500 MHz. Noise level should be less than -107 dBm.

_____ < -107 dBm

PERFORMANCE TESTS

4-17. AVERAGE NOISE LEVEL (Cont'd)

4. Set START-CENTER switch to CENTER and FREQ SPAN/DIV to 1 MHz. Adjust TUNING for a FREQUENCY MHz readout of 6 MHz and momentarily press FREQUENCY CAL switch.
5. Observe average noise level from 1 MHz to 11 MHz. Noise level should be less than -107 dBm.

_____ < -107 dBm

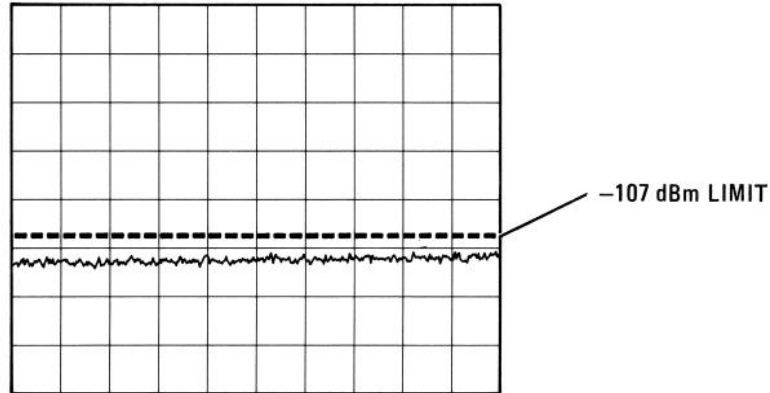

FIGURE 4-12. AVERAGE NOISE LEVEL MEASUREMENT

PERFORMANCE TESTS

4-18. SPURIOUS RESPONSES

SPECIFICATION

Image and multiple responses and second harmonic distortion products are > 70 dB* below a -40 dBm input signal with 0 dB input attenuation.

- 001: -35 dBm input signal
 002: $+15$ dBmV input signal

Third order intermodulation distortion products are > 70 dB* below two -30 dBm input signals, separated by ≥ 50 kHz, with 0 dB input attenuation.

- 001: two -25 dBm input signals
 002: two $+25$ dBmV input signals

* > 60 dB for 100 kHz to 5 MHz input signals.

DESCRIPTION:

A signal source with a lowpass filter is used to measure harmonic distortion. The LPF is required to ensure that the signals displayed on the CRT are due to harmonic distortion in the spectrum analyzer rather than to the harmonic content of the signal generator.

In measuring spurious responses due to image frequencies, out-of-band responses, and intermodulation distortion, signals from two separate sources are applied to the spectrum analyzer.

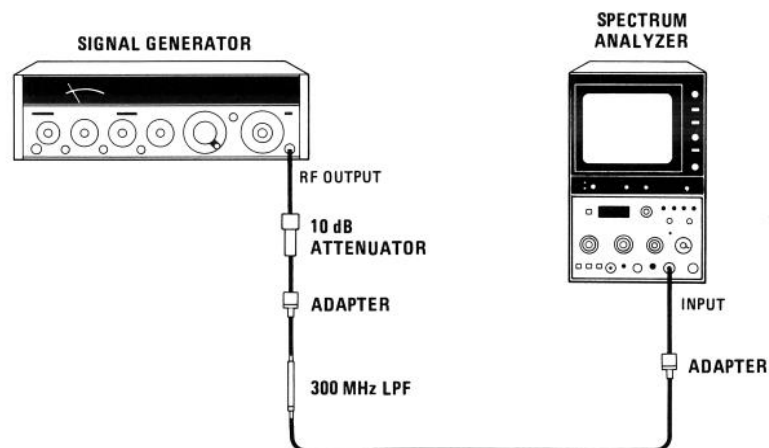

FIGURE 4-13. HARMONIC DISTORTION TEST SETUP

PERFORMANCE TESTS

4-18. SPURIOUS RESPONSES (Cont'd)

EQUIPMENT

Signal Generator (2 required)	HP 8640B
10 dB Attenuator (2 required)	HP 8491A Opt. 010
300 MHz LPF	Telonic TLP 300-4AB
Directional Bridge	HP 8721A
Adapter, Type N (m) to BNC (f) (3 required)	HP 1250-0780
BNC Cable, 120 cm (48 in) (2 required)	HP 10503A

Additional Equipment, Options 001 and 002:

<i>Minimum Loss Adapter, 75Ω to 50Ω</i>	<i>HP 08558-60031</i>
<i>BNC Cable, 30 cm (12 in), 75Ω</i>	<i>HP 11652-60012</i>
<i>Adapter, SMA (f) to SMA (f)</i>	<i>HP 1250-1158</i>
<i>Adapter, BNC (f) to SMA (m)</i>	<i>HP 1250-1200</i>

PROCEDURE

Harmonic Distortion

1. Set spectrum analyzer controls as follows:

START-CENTER	CENTER
TUNING	280 MHz
FREQ SPAN/DIV	500 kHz
RESOLUTION BW	30 kHz
INPUT ATTEN	0 dB
REFERENCE LEVEL	-40 dBm
001: -30 dBm	
002: +20 dBmV	
REF LEVEL FINE	0
001: -5	
002: -5	
Amplitude Scale	10 dB/DIV
SWEEP TIME/DIV	AUTO
SWEEP TRIGGER	FREE RUN
BASELINE CLIPPER	OFF
VIDEO FILTER	12 o'clock

2. Set signal generator frequency to 280 MHz and OUTPUT LEVEL to -30 dBm.
3. Connect equipment as shown in Figure 4-13.
4. Momentarily press FREQUENCY CAL switch. Tune signal generator to center signal on spectrum analyzer display.

PERFORMANCE TESTS

4-18. SPURIOUS RESPONSES (Cont'd)

5. Adjust signal generator OUTPUT LEVEL for -40 dBm displayed at top graticule line of spectrum analyzer CRT.

001: -35 dBm
002: $+15$ dBmV

6. Increase signal generator OUTPUT LEVEL by 20 dB.
7. Set spectrum analyzer TUNING to approximately 560 MHz and identify second harmonic.
8. Center signal on spectrum analyzer display and reduce signal generator OUTPUT LEVEL by 20 dB.
9. Set spectrum analyzer RESOLUTION BW to 3 kHz. Harmonics should be more than 70 dB below input signal (below first graticule line from bottom).

2nd Harmonic: _____ dB

3rd Harmonic: _____ dB

10. Set RESOLUTION BW to 30 kHz. Increase signal generator OUTPUT LEVEL by 20 dB.
11. Set spectrum analyzer TUNING to approximately 840 MHz and identify third harmonic.
12. Repeat steps 8 and 9.

Intermodulation Distortion

13. Set spectrum analyzer controls as follows:

START-CENTER	CENTER
TUNING	30 MHz
FREQ SPAN/DIV	500 kHz
RESOLUTION BW	30 kHz
INPUT ATTEN	0 dB
REFERENCE LEVEL	-30 dBm
001: -20 dBm	
002: $+30$ dBmV	
REF LEVEL FINE	0
001: -5	
002: -5	
Amplitude Scale	10 dB/DIV
SWEEP TIME/DIV	AUTO
SWEEP TRIGGER	FREE RUN
BASELINE CLIPPER	OFF
VIDEO FILTER	12 o'clock

PERFORMANCE TESTS

4-18. SPURIOUS RESPONSES (Cont'd)

14. Connect equipment as shown in Figure 4-14.

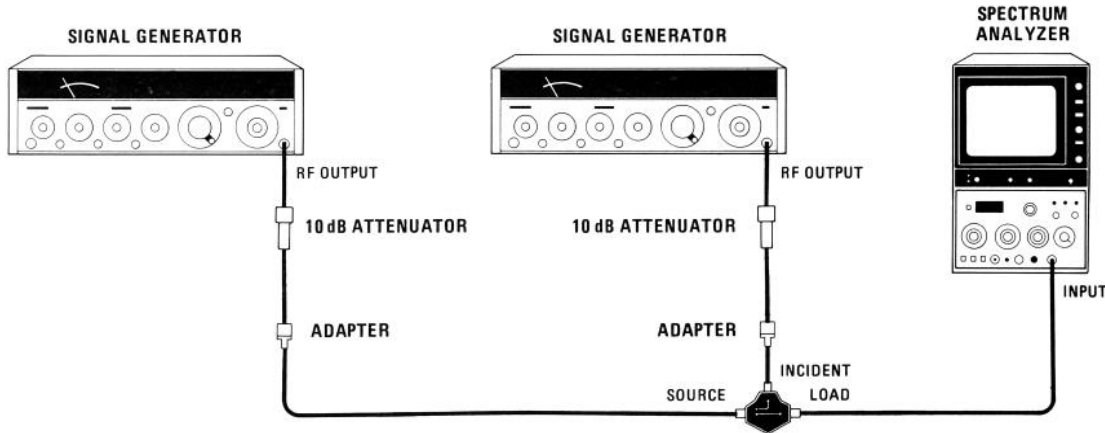

FIGURE 4-14. INTERMODULATION DISTORTION TEST SETUP

15. Set both signal generators for approximately 30 MHz output at -24 dBm.
16. Momentarily press FREQUENCY CAL switch. Tune signal generators until signals are 2 divisions apart and centered on display.
17. Adjust OUTPUT LEVEL controls of both signal generators for -30 dBm displayed on spectrum analyzer.

001: -25 dBm
 002: $+25$ dBmV

18. Reduce spectrum analyzer RESOLUTION BW to 3 kHz and check for third order intermodulation distortion products at approximately 3 divisions to either side of center graticule line (see NOTE below). They should be more than 70 dB below input signals (-100 dBm on spectrum analyzer display). (See Figure 4-15.)

001: -95 dBm on spectrum analyzer display
 002: -45 dBmV on spectrum analyzer display

_____dB

NOTE

If the intermodulation distortion product cannot be located, increase output levels of both signal generators by 10 dB. Be sure to return the OUTPUT LEVEL of each signal generator to its previous setting before making the actual measurement.

PERFORMANCE TESTS

4-18. SPURIOUS RESPONSES (Cont'd)

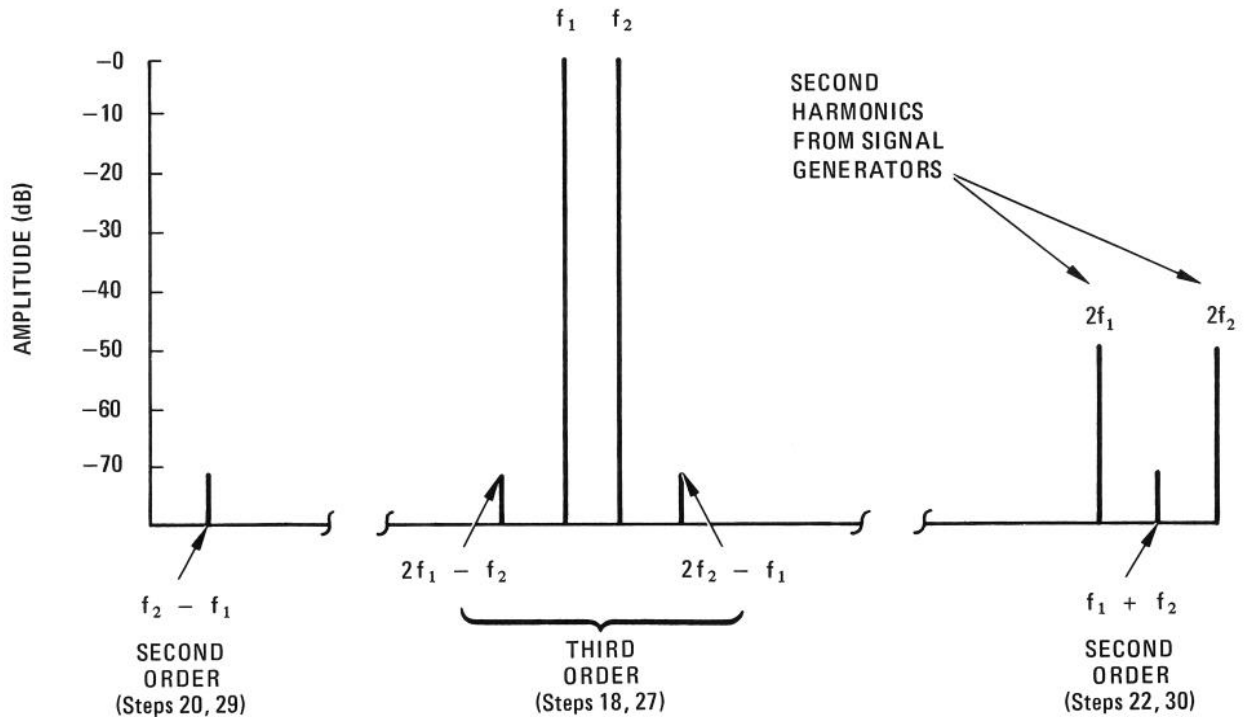

FIGURE 4-15. INTERMODULATION DISTORTION PRODUCTS

19. Set INPUT ATTEN to 0 dB, REFERENCE LEVEL to -40 dBm, and RESOLUTION BW to 30 kHz. Adjust OUTPUT LEVEL of each signal generator to -43 dBm as displayed on CRT.

001: REFERENCE LEVEL -35 dBm; output level of -38 dBm displayed on CRT

002: REFERENCE LEVEL +15 dBmV; output level of +12 dBmV displayed on CRT

20. Set spectrum analyzer TUNING to 1 MHz and momentarily press FREQUENCY CAL switch. Set RESOLUTION BW to 3 kHz and adjust VIDEO FILTER as necessary for more than 70 dB display range. Check for second order intermodulation distortion product ($f_2 - f_1$) near center of display (see NOTE, below). Second order intermodulation distortion product should be more than 70 dB below the total applied signal (-110 dBm on spectrum analyzer display). (See Figure 4-15.)

001: -105 dBm on spectrum analyzer display

002: -55 dBmV on spectrum analyzer display

_____dB

NOTE

If the intermodulation distortion product cannot be located, increase output levels of both signal generators by 10 dB. Be sure to return the OUTPUT LEVEL of each signal generator to its previous setting before making the actual measurement.

PERFORMANCE TESTS

4-18. SPURIOUS RESPONSES (Cont'd)

21. Set spectrum analyzer TUNING to 60 MHz and RESOLUTION BW to 30 kHz. Momentarily press FREQUENCY CAL switch.
22. Check for second order intermodulation distortion product ($f_1 + f_2$) between $2f_1$ and $2f_2$ signals (see NOTE below). Set RESOLUTION BW to 3 kHz and adjust VIDEO FILTER as necessary for more than 70 dB display range. Second order intermodulation distortion product should be more than 70 dB below total applied signal (– 110 dBm on spectrum analyzer display). (See Figure 4-15.)

001: – 105 dBm on spectrum analyzer display
 002: – 55 dBmV on spectrum analyzer display

_____dB

NOTE

If the intermodulation distortion product cannot be located, increase output levels of both signal generators by 10 dB. Be sure to return the OUTPUT LEVEL of each signal generator to its previous setting before making the actual measurement.

23. Set spectrum analyzer controls as follows:

START-CENTER	CENTER
TUNING	4 MHz
FREQ SPAN/DIV	500 kHz
RESOLUTION BW	30 kHz
INPUT ATTEN	0 dB
REFERENCE LEVEL	– 30 dBm
001: – 20 dBm	
002: + 30 dBmV	
REF LEVEL FINE	0
001: – 5	
002: – 5	
Amplitude Scale	10 dB/DIV
SWEEP TIME/DIV	AUTO
SWEEP TRIGGER	FREE RUN
BASELINE CLIPPER	OFF
VIDEO FILTER	12 o'clock

24. Set both signal generators for approximately 4 MHz at – 24 dBm.
25. Momentarily press FREQUENCY CAL switch. Tune signal generators until signals are 2 divisions apart and centered on display.
26. Adjust OUTPUT LEVEL of each signal generator for – 30 dBm as displayed on CRT.

001: – 25 dBm
 002: + 25 dBmV

 PERFORMANCE TESTS

4-18. SPURIOUS RESPONSES (Cont'd)

27. Check for third order intermodulation distortion products at approximately 3 divisions from either side of center graticule line. Third order intermodulation distortion products should be more than 60 dB below input signals (– 90 dBm on spectrum analyzer display).

001: – 85 dBm on spectrum analyzer display
 002: – 35 dBmV on spectrum analyzer display

_____dB

NOTE

If signal generators other than HP 8640's are used, intermodulation distortion might be in the generators themselves because of crosstalk between the two sources.

28. Set INPUT ATTEN to 0 dB and REFERENCE LEVEL to – 40 dBm. Adjust OUTPUT LEVEL of each signal generator for – 43 dBm as displayed on CRT.

001: REFERENCE LEVEL, – 35 dBm; output level of – 38 dBm displayed on CRT
 002: REFERENCE LEVEL, + 15 dBmV; + 12 dBmV as displayed on CRT

29. Set spectrum analyzer TUNING to 1 MHz and momentarily press FREQUENCY CAL switch. Set RESOLUTION BW to 3 kHz and adjust VIDEO FILTER as necessary for more than 70 dB display range. Check for second order intermodulation distortion product ($f_2 - f_1$) near center of display (see NOTE below). Second order intermodulation distortion product should be more than 60 dB below total applied signal (– 100 dBm on spectrum analyzer display). (See Figure 4-15.)

001: – 95 dBm on spectrum analyzer display
 002: – 45 dBmV on spectrum analyzer display

_____dB

NOTE

If the intermodulation distortion product cannot be located, increase output levels of both signal generators by 10 dB. Be sure to return the OUTPUT LEVEL of each signal generator to its previous setting before making the actual measurement.

30. Set spectrum analyzer TUNING to 8 MHz and check for second order intermodulation distortion product ($f_1 + f_2$) between $2f_1$ and $2f_2$ signals. (See figure 4-15.) Second order intermodulation distortion product should be more than 60 dB below total applied signal (– 100 dBm on spectrum analyzer display). (See NOTE above.)

001: – 95 dBm on spectrum analyzer display
 002: – 45 dBmV on spectrum analyzer display

_____dB

PERFORMANCE TESTS

4-19. RESIDUAL RESPONSES

SPECIFICATION

< - 100 dBm (1-1500 MHz) with 0 dB input attenuation and no signal present at input.

- 001: < - 95 dBm
- 002: < - 50 dBmV

DESCRIPTION

The spectrum analyzer is tested for residual responses with no signal applied to the INPUT 50Ω connector. The input attenuation is set to 0 dB.

001 and 002: INPUT 75Ω

EQUIPMENT

- Variable Persistence/Storage Display HP 181T
- 50-Ohm Termination HP 11593A

Additional Equipment, Options 001 and 002:

- 75-Ohm Termination HP 11652-60010

NOTE

The HP 853A Spectrum Analyzer Display may be substituted for the HP 181T/TR in this procedure.

PROCEDURE

1. Set spectrum analyzer controls as follows:

- START-CENTER CENTER
 - TUNING 500 MHz
 - FREQ SPAN/DIV 100 MHz
 - RESOLUTION BW 1 MHz
 - INPUT ATTEN 0 dB
 - REFERENCE LEVEL - 60 dBm
 - 002: -10 dBmV
 - Amplitude Scale 10 dB/DIV
 - SWEEP TIME/DIV AUTO
 - SWEEP TRIGGER FREE RUN
 - VIDEO FILTER Fully clockwise (not in detent)
-

 PERFORMANCE TESTS

4-19. RESIDUAL RESPONSES (Cont'd)

2. Terminate INPUT 50Ω connector with 50-ohm coaxial termination.

001 and 002: 75Ω; 75-ohm

3. With variable persistence display in NORM mode, set LO feedthrough to far left vertical graticule line. Set BASELINE CLIPPER to 3 o'clock.
4. Set HP 181T to WRITE mode. Set PERSISTENCE control to MAX and INTENSITY control to approximately 12 o'clock.
5. Set spectrum analyzer SWEEP TRIGGER to SINGLE sweep mode and RESOLUTION BW to 30 kHz. Momentarily press ERASE pushbutton.

NOTE

When the ERASE pushbutton is pressed, the spectrum analyzer sweep might be triggered. To stop the sweep, turn SWEEP TRIGGER control clockwise.

6. Turn SWEEP TRIGGER control clockwise to initiate sweep.
7. Slowly turn BASELINE CLIPPER control until peaks of trace begin to appear on display. It might be necessary to increase baseline clipping slightly near end of sweep to reduce blooming.
8. Trigger sweep at least one more time and check for residual responses from 1 to 1000 MHz. Record frequency at which residual response of greatest amplitude appears.

_____MHz

9. Set display to NORM mode. Set spectrum analyzer BASELINE CLIPPER fully counterclockwise and SWEEP TRIGGER to FREE RUN.
10. Set FREQ SPAN/DIV to 20 kHz and TUNING to center frequency of residual recorded in step 8.
11. Narrow FREQ SPAN/DIV and RESOLUTION BW, using TUNING control to keep signal centered. Use SWEEP TIME/DIV control to reduce sweep speed until signal level does not rise when sweep speed is further reduced. Residual response must be less than -100 dBm.

_____dBm

001: < -95 dBm
002: < -50 dBmV

12. Repeat steps 1 through 5.
13. Set START-CENTER switch to START and repeat steps 6 and 7.

PERFORMANCE TESTS

4-19. RESIDUAL RESPONSES (Cont'd)

14. Trigger sweep at least one more time and check for residual responses from 500 MHz to 1500 MHz. Record frequency at which residual response of greatest amplitude appears.

_____MHz

15. Repeat step 9.

16. Set spectrum analyzer **FREQ SPAN/DIV** to 20 kHz and **TUNING** to center frequency of residual recorded in step 14.

17. Narrow **FREQ SPAN/DIV** and **RESOLUTION BW**, using **TUNING** control to keep signal centered. Use **SWEEP TIME/DIV** control to reduce sweep speed until signal level does not rise when sweep speed is further reduced. Residual response must be less than -100 dBm.

_____dBm

001: < -95 dBm

002: < -50 dBmV

PERFORMANCE TESTS

4-20. FREQUENCY RESPONSE

SPECIFICATION

$\leq \pm 1.0$ dB with 10 dB input attenuation

DESCRIPTION

Signals from 0.1 to 1500 MHz are applied to the input of the spectrum analyzer. The amplitude of each signal is adjusted to a reference set on the analyzer display. The power level, measured with a power meter, determines the frequency response of the spectrum analyzer.

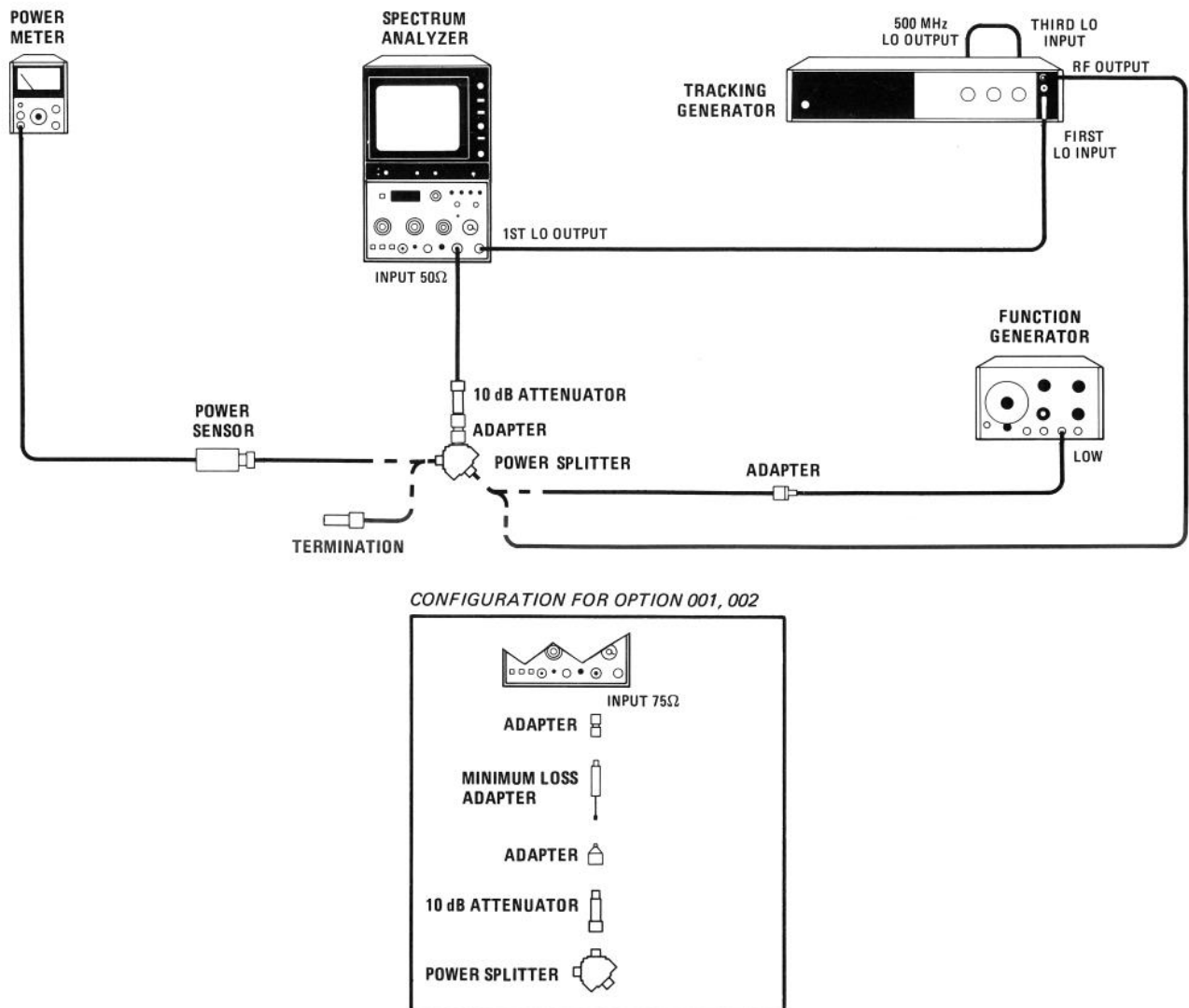

FIGURE 4-16. FREQUENCY RESPONSE TEST SETUP

PERFORMANCE TESTS

4-20. FREQUENCY RESPONSE (Cont'd)

EQUIPMENT

Tracking Generator	HP 8444A Opt. 059
Power Meter	HP 435B
Power Sensor	HP 8482A
Function Generator	HP 3310A
Power Splitter	HP 11667A
BNC Cable, 20 cm (9 in).	HP 10502A
BNC Cable, 120 cm (48 in).	HP 10503A
Type N cable, 180 cm (72 in)	HP 11500A
10 dB Attenuator	HP 8491B Opt. 010
Adapter, Type N (m) to Type N (m)	HP 1250-1475
Adapter, Type N (m) to BNC (f).	HP 1250-0780

Additional Equipment, Options 001 and 002:

BNC Cable, 30 cm (12 in), 75Ω	HP 11652-60012
Adapter, Type N (m) to SMA (f), 50Ω	HP 1250-1250
Minimum Loss Adapter, 75Ω to 50Ω	HP 08558-60031

PROCEDURE

1. Set controls as follows:

Spectrum Analyzer:

START – CENTER	CENTER
TUNING	0
FREQ SPAN/DIV	0
RESOLUTION BW	100 kHz
INPUT ATTEN	10 dB
REFERENCE LEVEL	- 10 dBm
002: + 40 dBmV	
Amplitude Scale	10 dB/DIV
SWEEP TIME/DIV	AUTO
SWEEP TRIGGER	FREE RUN
BASELINE CLIPPER	OFF
VIDEO FILTER	OFF

2. Adjust spectrum analyzer TUNING to peak LO feedthrough signal on display. Press FREQUENCY CAL and readjust TUNING for peak. Repeat. Adjust TUNING for peak and adjust FREQUENCY ZERO for a FREQUENCY MHz reading of 00.0.
3. Adjust TUNING for a FREQUENCY MHz reading of 5.0 MHz. Press FREQUENCY CAL. Set up equipment as shown in Figure 4-16. Connect the tracking generator 500 MHz LO OUTPUT to the THIRD LO INPUT (rear panel).
4. Set spectrum analyzer Amplitude Scale to 1 dB/DIV and adjust REF LEVEL FINE to bring the trace on the display. Peak the trace using tracking generator TRACK ADJ.

PERFORMANCE TESTS

4-20. FREQUENCY RESPONSE (Cont'd)

5. Set power meter CAL FACTOR according to chart on power probe (5 MHz). Set RANGE to - 10 dBm.
6. Adjust tracking generator LEVEL to set a reference of - 12 dBm on the power meter.
7. Adjust spectrum analyzer REF LEVEL FINE to position trace to fourth graticule line.
8. For each setting in Table 4-5:
 - a. Adjust spectrum analyzer TUNING and press FREQUENCY CAL.
 - b. Set power meter CAL FACTOR.
 - c. Adjust tracking generator TRACK ADJ to peak signal on display and adjust LEVEL to place signal on reference graticule.
 - d. Record Power Meter Reading.
9. Disconnect Type N cable from power splitter. Connect function generator LOW output to power splitter.
10. Set controls as follows:

Spectrum Analyzer	
FREQ SPAN/DIV	50 kHz
RESOLUTION BW	10 kHz
Amplitude Scale	10 dB/DIV
Function Generator:	
RANGE	100 kHz
Frequency	5 MHz
FUNCTION	SINE
DC OFFSET	0
11. Set power meter CAL FACTOR according to chart on power sensor (5 MHz). Adjust spectrum analyzer TUNING to center 5 MHz signal on display. Set amplitude scale to 1 dB/DIV.
12. Adjust function generator OUTPUT LEVEL to - 12 dB on power meter.
13. Adjust REF LEVEL FINE to bring the peak of the 5 MHz signal to fourth graticule from bottom.
14. For each frequency in Table 4-6, set function generator frequency and tune spectrum analyzer to bring signal to center screen. Adjust function generator OUTPUT LEVEL to bring signal peak to reference graticule on the display. Set the power meter CAL FACTOR and record the power indicated by the power meter.
15. Find the overall maximum power reading from both Table 4-5 and Table 4-6. _____dBm

PERFORMANCE TESTS

4-20. FREQUENCY RESPONSE (Cont'd)

16. Find the overall minimum power reading from both Table 4-5 and Table 4-6 . _____dBm

17. The difference between the overall maximum power in step 15 and the overall minimum power in step 16 should be less than 2 dB. _____dB

TABLE 4-5. FREQUENCY RESPONSE, 5 MHz TO 1500 MHz

Spectrum Analyzer TUNING (MHz)	Power Meter Reading (dBm)
5	-12 (Ref.)
100	_____
200	_____
300	_____
400	_____
500	_____
600	_____
700	_____
800	_____
900	_____
1000	_____
1100	_____
1200	_____
1300	_____
1400	_____
1500	_____

TABLE 4-6. FREQUENCY RESPONSE, 100 kHz TO 5 MHz

Spectrum Analyzer/Function Generator Frequency	Power Meter Reading (dBm)
5 MHz	-12 (Ref.)
3 MHz	_____
1 MHz	_____
500 kHz	_____
100 kHz	_____

PERFORMANCE TESTS

4-21. BANDWIDTH SWITCHING (AMPLITUDE VARIATION)

SPECIFICATION

3 MHz to 300 kHz: $\leq \pm 0.5$ dB
 3 MHz to 1 kHz: $\leq \pm 1.0$ dB (100 kHz bandwidth limited to $< 80\%$ R.H.)

DESCRIPTION

The spectrum analyzer 280 MHz CAL OUTPUT signal is applied to the INPUT connector and displayed on the CRT. The peak of the displayed 280 MHz signal is centered on the CRT and adjusted for a vertical deflection of seven divisions. The amplitude variation of the 280 MHz signal is measured for each RESOLUTION BW control setting. The overall variation between RESOLUTION BW settings of 3 MHz to 300 kHz should be equal to or less than 1 dB (± 0.5 dB). The overall variation between RESOLUTION BW settings of the 3 MHz to 1 kHz should be equal to or less than 2 dB (± 1.0 dB).

EQUIPMENT

BNC Cable, 20 cm (9 in) HP 10502A
 Adapter, Type N (m) to BNC (f) HP 1250-0780

Additional Equipment, Options 001 and 002:

BNC Cable, 30 cm (12 in), 75 Ω HP 11652-60012

PROCEDURE

1. Set spectrum analyzer controls as follows:

START – CENTER CENTER
 TUNING 280 MHz
 FREQ SPAN/DIV 1 MHz
 RESOLUTION BW 3 MHz
 INPUT ATTEN 0 dB
 REFERENCE LEVEL -20 dBm
 002: +30 dBm
 REF LEVEL FINE -10
 Amplitude Scale 1 dB/DIV
 SWEEP TIME/DIV AUTO
 SWEEP TRIGGER FREE RUN
 BASELINE CLIPPER OFF
 VIDEO FILTER OFF

2. Connect spectrum analyzer CAL OUTPUT signal to INPUT 50 Ω connector.
 001 and 002: 75 Ω

PERFORMANCE TESTS

4-21. BANDWIDTH SWITCHING (AMPLITUDE VARIATION) (Cont'd)

3. Set TUNING control, as required, to center 280 MHz signal on CRT.
4. Set REF LEVEL FINE control to position peak of 280 MHz signal seven divisions above graticule baseline.
5. Vary the RESOLUTION BW and FREQ SPAN/DIV controls in accordance with Table 4-7. Record the change in amplitude for each RESOLUTION BW setting. Changes in amplitude above reference level set in step 4 are positive (+). Changes below reference level are negative (-).

TABLE 4-7. AMPLITUDE ACCURACY, SWITCHING BETWEEN BANDWIDTHS

RESOLUTION BW Setting	FREQ SPAN/DIV Setting	Change in Amplitude (dB)	Overall Variation Between 3 MHz and 300 kHz RESOLUTION BW Settings (dB)	Overall Variation Between 3 MHz and 1 kHz RESOLUTION BW Settings (dB)
3 MHz 1 MHz 300 kHz	1 MHz 500 kHz 100 kHz	0 (Ref) _____ _____	_____	_____
100 kHz 30 kHz 10 kHz 3 kHz 1 kHz	50 kHz 10 kHz 5 kHz 5 kHz 5 kHz	_____ _____ _____ _____ _____	_____	_____

6. To find the overall variation in Table 4-7, algebraically subtract the greatest negative change in amplitude from the greatest positive change in amplitude. If all changes in amplitude are of the same sign, the overall variation is the largest positive or largest negative change in amplitude. The overall variation between 3 MHz and 300 kHz RESOLUTION BW settings should be ≤ 1.0 dB (± 0.5 dB). The overall variation between 3 MHz and 1 kHz RESOLUTION BW settings should be ≤ 2.0 dB (± 1.0 dB).

PERFORMANCE TESTS

4-22. INPUT ATTENUATOR ACCURACY

SPECIFICATION

Accuracy ± 0.5 dB for each 10 dB step but not more than ± 1.0 dB over full 70 dB range.

DESCRIPTION

The input attenuator accuracy is tested over its full 70 dB range using an RF substitution method. A step attenuator that has been calibrated by a Standards Laboratory at 30 MHz is used for substitution. The known error of the calibrated attenuator is taken into account when computing the 8558B input attenuator accuracy.

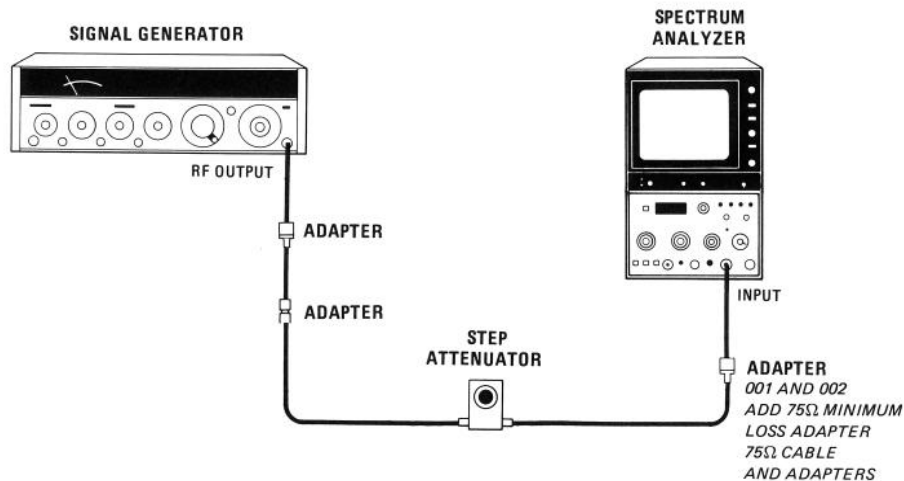

FIGURE 4-17. INPUT ATTENUATOR ACCURACY TEST SETUP

EQUIPMENT

Signal Generator	HP 8640B
Step Attenuator	HP 355D Opt. H82
Adapter, Type N (m) to BNC (f) (2 required)	HP 1250-0780
Adapter, BNC (m) to BNC (m).....	HP 1250-0216
BNC Cable, 120 cm (48 in).....	HP 10503A

Additional Equipment, Options 001 and 002:

<i>Minimum Loss Adapter, 75Ω to 50Ω</i>	<i>HP 08558-60031</i>
<i>BNC Cable, 30 cm (12 in), 75Ω</i>	<i>HP 11652-60012</i>
<i>Adapter, SMA (f) to SMA (f)</i>	<i>HP 1250-1158</i>
<i>Adapter, BNC (f) to SMA (m)</i>	<i>HP 1250-1200</i>

PERFORMANCE TESTS

4-22. INPUT ATTENUATOR ACCURACY (Cont'd)

PROCEDURE

1. Set controls as follows:

Spectrum Analyzer

START – CENTER CENTER
 TUNING 30 MHz
 FREQ SPAN/DIV 200 kHz
 RESOLUTION BW 30 kHz
 INPUT ATTEN 70 dB
 REFERENCE LEVEL 0 dBm
 001: -10 dBm
 002: +40 dBmV
 Amplitude Scale 1 dB/DIV
 SWEEP TIME/DIV AUTO
 SWEEP TRIGGER FREE RUN
 BASELINE CLIPPER OFF
 VIDEO FILTER 2 o'clock

Signal Generator

COUNTER MODE INT
 AM OFF
 FM OFF
 FREQUENCY TUNE 30.0 MHz
 OUTPUT LEVEL 0 dBm
 RF ON

2. Connect equipment as shown in Figure 4-17 with step attenuator set at 0 dB. Locate signal on CRT and adjust signal generator OUTPUT LEVEL until signal peak is 6 divisions above graticule baseline.
3. Set HP 8558B INPUT ATTEN control and step attenuator to settings indicated in Table 4-8. Record deviation from sixth division reference set in step 2 for each setting.

TABLE 4-8. INPUT ATTENUATOR ACCURACY

INPUT ATTEN Setting (dBm)	Step Attenuator Setting (dB)	Deviation from 6th Division (dB)	Step Attenuator Error (Calibration)*	Corrected Deviation (dB)
70	0	0 (Ref.)	Ref.	0 (Ref.)
60	10	_____	_____	_____
50	20	_____	_____	_____
40	30	_____	_____	_____
30	40	_____	_____	_____
20	50	_____	_____	_____
10	60	_____	_____	_____
0	70	_____	_____	_____

*Attenuations > dial settings are positive (+). Attenuations < dial settings are negative (-). For example, 9.99 dB calibration for a 10 dB attenuator setting represents an error of -0.01 dB.

PERFORMANCE TESTS

4-22. INPUT ATTENUATOR ACCURACY (Cont'd)

4. To compute Corrected Deviation, add Step Attenuator Error to Deviation from 6th Division for each setting. Corrected Deviation should not differ more than 0.5 dB between any two adjacent settings of input attenuator.

_____ Error Between Adjacent Settings

5. Record maximum positive and maximum negative Corrected Deviation values. Difference between these two values (total deviation) should not exceed 2.0 dB (± 1.0 dB).

_____ dB Maximum Positive Corrected Deviation

_____ dB Maximum Negative Corrected Deviation

_____ dB Total Corrected Deviation

PERFORMANCE TESTS

4-23. REFERENCE LEVEL ACCURACY

SPECIFICATION

Step Accuracy:

Steps referenced with 0 dB input attenuation

- 10 dBm to - 80 dBm: ±0.5 dB

- 10 dBm to - 100 dBm: ±1.0 dB

Vernier Accuracy:

±0.5 dB

DESCRIPTION

The reference level accuracy is tested over the range of - 10 dBm to - 100 dBm by checking the IF gain steps in 1 dB/DIV (Log) and in LIN. The resulting maximum deviation in each case must be less than 1.0 dB (±0.5 dB) from - 10 dBm to - 80 dBm and less than 2.0 dB (±1.0 dB) from - 10 dBm to - 100 dBm.

002: Change range to “+ 40 dBmV to - 50 dBmV”.

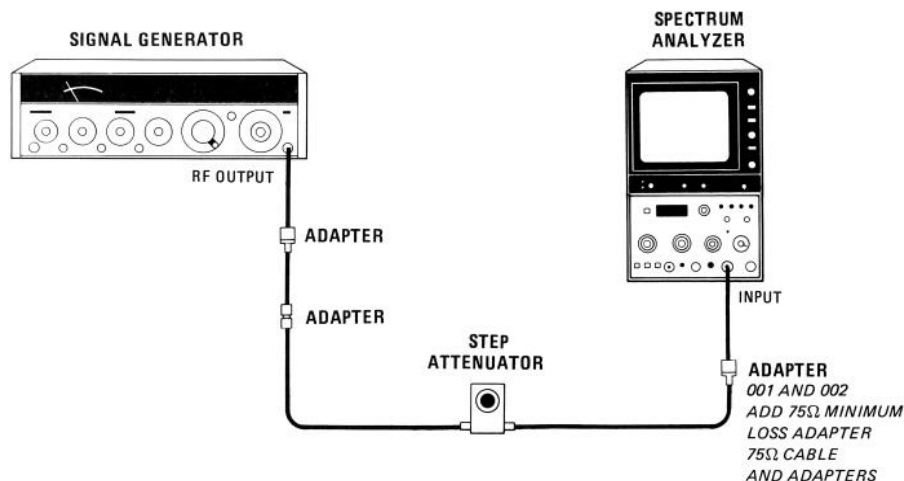

FIGURE 4-18. REFERENCE LEVEL ACCURACY TEST SETUP

EQUIPMENT

Signal Generator	HP 8640B
1 dB Step Attenuator	HP 355C Opt. H80
10 dB Step Attenuator	HP 355D Opt. H82
Adapter (2 required).....	HP 1250-0780
BNC Cable, 20 cm (9 in).....	HP 10502A
BNC Cable, 120 cm (48 in).....	HP 10503A

Additional Equipment, Options 001 and 002:

Minimum Loss Adapter, 75Ω to 50Ω	HP 08558-60031
BNC Cable, 30 cm (12 in), 75Ω	HP 11652-60012
Adapter, SMA (f) to SMA (f)	HP 1250-1158
Adapter, BNC (f) to SMA (m)	HP 1250-1200

PERFORMANCE TESTS

4-23. REFERENCE LEVEL ACCURACY (Cont'd)

PROCEDURE

Step Accuracy in Log Mode

1. Set controls as follows:

Spectrum Analyzer

START – CENTER	CENTER
TUNING	30 MHz
FREQ SPAN/DIV	5 kHz
RESOLUTION BW	3 kHz
INPUT ATTEN	0 dB
REFERENCE LEVEL dBm	-10 dBm
<i>002: +40 dBmV</i>	
Amplitude Scale	1 dB/DIV
SWEEP TIME/DIV	AUTO
SWEEP TRIGGER	FREE RUN
BASELINE CLIPPER	OFF
VIDEO FILTER	2 o'clock

Signal Generator

COUNTER MODE	INT
AM	OFF
FM	OFF
FREQUENCY TUNE	30 MHz
OUTPUT LEVEL	-10 dBm

2. Connect equipment in Figure 4-18 with step attenuator set at 0 dB. Locate signal on CRT.

NOTE

If signal is difficult to locate, press RESOLUTION BW control to couple with FREQ SPAN/DIV control and turn the coupled controls clockwise until signal appears on display. Momentarily depress FREQ CAL switch and center the signal, using TUNING control. Return controls to positions called out in step 1, adjusting TUNING control as necessary to keep signal centered.

3. Adjust signal generator OUTPUT LEVEL until trace is 6 divisions above graticule baseline. Set the 8558B REFERENCE LEVEL control and step attenuator to settings indicated in Table 4-9. Record the Deviation from the 6th Division (reference set in step 2) for each setting.
4. To compute the Corrected Deviation, add the Step Attenuator Error to the Deviation from 6th Division for each setting. The difference between the maximum positive and the maximum negative Corrected Deviation values from -10 dBm to -80 dBm should not exceed 1.0 dB. The difference between the maximum positive and the maximum negative Corrected Deviation values from -10 dBm to -100 dBm should not exceed 2.0 dB.

-10 dBm to -80 dBm _____ dB
 -10 dBm to -100 dBm _____ dB

002: Change ranges to "+40 dBmV to -30 dBmV" and "+40 dBmV to -50 dBmV".

PERFORMANCE TESTS

4-23. REFERENCE LEVEL ACCURACY (Cont'd)

TABLE 4-9. IF GAIN ACCURACY IN LOG MODE

REFERENCE LEVEL Setting (dBm)	Step Attenuator Setting (dB)	Deviation from 6th Division (dB)	Step Attenuator Error (Calibration)* (dB)	Corrected Deviation (dB)
-10	0	0 (Ref.)	Ref.	0 (Ref.)
-20	10	_____	_____	_____
-30	20	_____	_____	_____
-40	30	_____	_____	_____
-50	40	_____	_____	_____
-60	50	_____	_____	_____
-70	60	_____	_____	_____
-80	70	_____	_____	_____
-90	80	_____	_____	_____
-100	90	_____	_____	_____

002: REFERENCE LEVEL (dBmV) from top to bottom: 40, 30, 20, 10, 0, -10, -20, -30, -40, -50.

*Attenuations > dial settings are positive (+). Attenuations < dial settings are negative (-). For example, 9.99 dB calibration for a 10 dB attenuator setting represents an error of -0.01 dB.

Step Accuracy in Linear Mode

5. Set the spectrum analyzer Amplitude Scale switch to LIN. Set REFERENCE LEVEL control to -10 dBm and set step attenuator to 0 dB. Readjust signal generator OUTPUT LEVEL until trace is 6 divisions above graticule baseline.

002: REFERENCE LEVEL, +40 dBmV.

6. Set the 8558B REFERENCE LEVEL control and step attenuator to settings indicated in Table 4-10. Record the Deviation from the 6th Division in Linear Mode (reference set in step 5) for each setting.

7. Using Table 4-11, convert Deviation from 6th Division in Linear Mode to deviation in dB for each setting. Record dB values in Table 4-10.

8. To compute the Corrected Deviation, add the Step Attenuator Error to the Deviation from the 6th Division in dB. The difference between the maximum positive and the maximum negative Corrected Deviation values from -10 dBm to -80 dBm should not exceed 1.0 dB. The difference between the maximum positive and the maximum negative Corrected Deviation values from -10 dBm to -100 dBm should not exceed 2.0 dB.

002: Change ranges to "+40 dBmV to -30 dBmV" and "+40 dBmV to -50 dBmV".

-10 dBm to -80 dBm _____ dB
 -10 dBm to -100 dBm _____ dB

PERFORMANCE TESTS

4-23. REFERENCE LEVEL ACCURACY (Cont'd)

TABLE 4-10. IF GAIN ACCURACY IN LINEAR MODE

REFERENCE LEVEL Setting (dBm)	Step Attenuator Setting (dB)	Deviation from 6th Division in Linear Mode (div.)	Deviation from 6th Division in dB*	Step Attenuator Error (Calibration)** (dB)	Corrected Deviation (dB)
-10	0	0 (Ref.)	0 (Ref.)	Ref.	0 (Ref.)
-20	10	_____	_____	_____	_____
-30	20	_____	_____	_____	_____
-40	30	_____	_____	_____	_____
-50	40	_____	_____	_____	_____
-60	50	_____	_____	_____	_____
-70	60	_____	_____	_____	_____
-80	70	_____	_____	_____	_____
-90	80	_____	_____	_____	_____
-100	90	_____	_____	_____	_____

002: REFERENCE LEVEL (dBmV) from top to bottom: 40, 30, 20, 10, 0, -10, -20, -30, -40, -50.

*Use Table 4-11 to convert deviation in linear mode to deviation in dB.
 **Attenuations > dial settings are positive (+). Attenuations < dial settings are negative (-).

TABLE 4-11. CONVERSION TABLE, DEVIATION IN LINEAR MODE

POSITIVE DEVIATIONS (Above 6th division from graticule baseline)		NEGATIVE DEVIATIONS (Below 6th division from graticule baseline)	
Linear (Divisions)	dB	Linear (Divisions)	dB
0	0	0	0
+1	+0.14	-1	-0.15
+2	+0.28	-2	-0.29
+3	+0.42	-3	-0.45
+4	+0.56	-4	-0.60
+5	+0.70	-5	-0.76
+6	+0.82	-6	-0.92
+7	+0.96	-7	-1.08
+8	+1.09	-8	-1.24
+9	+1.21	-9	-1.41
+1.0	+1.34	-1.0	-1.58
+1.1	+1.46	-1.1	-1.76
+1.2	+1.58	-1.2	-1.94
+1.3	+1.70		
+1.4	+1.82		
+1.5	+1.94		

PERFORMANCE TESTS

4-23. REFERENCE LEVEL ACCURACY (Cont'd)

Vernier Accuracy

9. Replace 10 dB step attenuator with 1 dB step attenuator. Set spectrum analyzer as follows:

REFERENCE LEVEL - 10 dBm
 REFERENCE LEVEL FINE 0
 Amplitude Scale 1 dB/DIV
 FREQ SPAN/DIV 50 kHz
 RESOLUTION BW 300 kHz

10. Center the signal on the CRT and adjust signal generator OUTPUT LEVEL until trace is 6 divisions above graticule baseline. Set step attenuator and spectrum analyzer REFERENCE LEVEL FINE to settings indicated in Table 4-12. Record Deviation from 6th Division for each setting.

11. To compute Corrected Deviation, add Step Attenuator Error to Deviation from 6th Division for each setting. Corrected Deviation should not exceed +0.5 dB or -0.5 dB for each setting.

TABLE 4-12. VERNIER ACCURACY

Step Attenuator Setting (dB)	REFERENCE LEVEL FINE Setting	Deviation From 6th Division (dB)	Step Attenuator Error (Calibration)* (dB)	Corrected Deviation (dB)
0	0	0 (Ref.)	Ref.	0 (Ref.)
1	-1	_____	_____	_____
2	-2	_____	_____	_____
3	-3	_____	_____	_____
4	-4	_____	_____	_____
5	-5	_____	_____	_____
6	-6	_____	_____	_____
7	-7	_____	_____	_____
8	-8	_____	_____	_____
9	-9	_____	_____	_____
10	-10	_____	_____	_____
11	-11	_____	_____	_____
12	-12	_____	_____	_____

*Attenuations > dial settings are positive (+). Attenuations < dial settings are negative (-).

PERFORMANCE TESTS

4-24. DISPLAY FIDELITY

SPECIFICATION

- Log Incremental Accuracy:
 - ± 0.1 dB per dB from Reference Level
- Log Maximum Cumulative Error:
 - < ± 1.5 dB over entire 70-dB range
- Linear Accuracy:
 - ± 3% of Reference Level

DESCRIPTION

The amplitude log display amplifier is tested by connecting a DVM to the rear panel AUX A connector (vertical output) of the mainframe. The widest analyzer bandwidth possible is selected so the signal appears as a straight horizontal line on the CRT display. The DVM is used to provide good resolution when checking for ± 1 dB per 10 dB step (0.1 dB/dB).

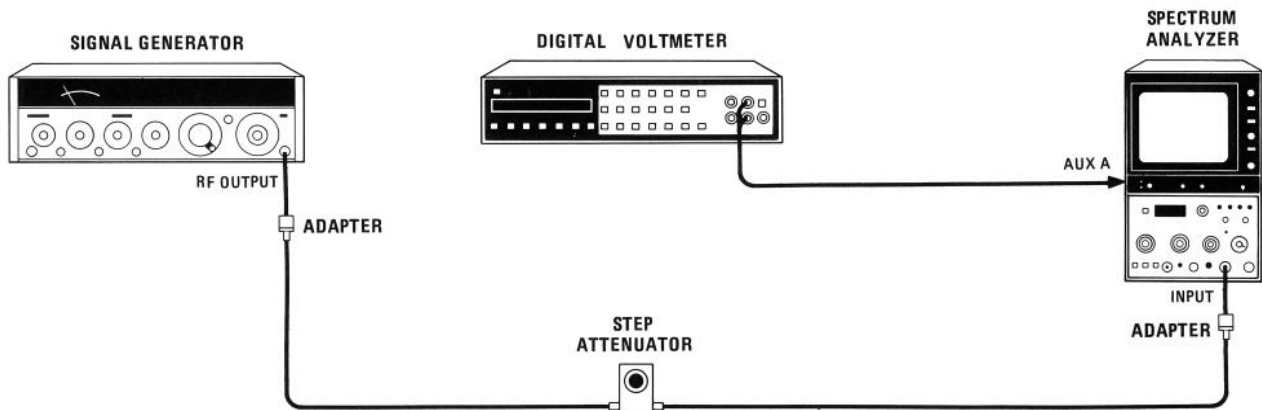

FIGURE 4-19. AMPLITUDE LOG DISPLAY ACCURACY TEST SETUP

EQUIPMENT

Signal Generator	HP 8640B
Digital Voltmeter	HP 3455A
10 dB Step Attenuator	HP 355D Opt. H82
Adapter, Type N (m) to BNC (f) (2 required)	HP 1250-0780
Cable, BNC to Banana Plug	HP 11001A

Additional Equipment, Options 001 and 002:

<i>Minimum Loss Adapter, 75Ω to 50Ω</i>	<i>HP 08558-60031</i>
<i>BNC Cable, 30 cm (12 in), 75Ω</i>	<i>HP 11652-60012</i>
<i>Adapter, SMA (f) to SMA (f)</i>	<i>HP 1250-1158</i>
<i>Adapter, BNC (f) to SMA (m)</i>	<i>HP 1250-1200</i>

PERFORMANCE TESTS

4-24. DISPLAY FIDELITY (Cont'd)

PROCEDURE

Log Display Accuracy

1. Set controls as follows:

Spectrum Analyzer

START – CENTER	CENTER
TUNING.....	30 MHz
FREQ SPAN/DIV	500 kHz
RESOLUTION BW	300 kHz
INPUT ATTEN	10 dB
REFERENCE LEVEL.....	0 dBm
002: +50 dBmV	
REF LEVEL FINE	0
Amplitude Scale	LIN
SWEEP TIME/DIV	AUTO
SWEEP TRIGGER.....	FREE RUN
BASELINE CLIPPER	OFF
VIDEO FILTER.....	OFF

Digital Voltmeter

RANGE	100
FUNCTION.....	V (DC)
AUTO CAL	AUTO
TRIGGER	INTERNAL
MATH	OFF

Signal Generator

FREQUENCY	30 MHz
COUNTERMODE	INT
OUTPUT LEVEL	0 dBm
AM.....	OFF
FM.....	OFF

2. With no signal at INPUT, measure and record the vertical output (AUX A) offset of the spectrum analyzer. _____mV
3. Connect equipment as shown in Figure 4–19. Tune signal generator to 30 MHz and set power output for approximately 0 dBm. Set step attenuator to 0 dB.
4. Set spectrum analyzer Amplitude Scale to 10 dB/DIV and adjust TUNING control to center the signal on CRT display.
5. Set the FREQ SPAN/DIV control to zero (0) and RESOLUTION BW control to 100 kHz. Tune the signal generator frequency for maximum reading on DVM.

PERFORMANCE TESTS

4-24. DISPLAY FIDELITY (Cont'd)

- Set the signal generator OUTPUT LEVEL so the DVM reads + 800 mV plus the offset (step 2) ± 0.5 mV. The trace should be approximately at the top graticule line.

TABLE 4-13. AMPLITUDE LOG DISPLAY ACCURACY

Attenuator Setting (dB)	DVM Reading (mV)	Corrected DVM Reading* (mV)	AUX A Theoretical Reading (mV)	AUX A Theoretical Reading Subtracted From Corrected DVM Reading (mV)	Difference Between Adjacent Readings (mV)
0		+800 (Ref.)	+800	0	
10	_____	_____	+700	_____	_____
20	_____	_____	+600	_____	_____
30	_____	_____	+500	_____	_____
40	_____	_____	+400	_____	_____
50	_____	_____	+300	_____	_____
60	_____	_____	+200	_____	_____
70	_____	_____	+100	_____	_____

*DVM Reading minus offset recorded in step 2.

Example (+ 5 mV offset):

TABLE 4-14. SAMPLE COMPUTATIONS OF AMPLITUDE LOG DISPLAY ACCURACY

Attenuator Setting (dB)	DVM Reading (mV)	Corrected DVM Reading* (mV)	AUX A Theoretical Reading (mV)	AUX A Theoretical Reading Subtracted From Corrected DVM Reading (mV)	Difference Between Adjacent Readings (mV)
0	+805	+800	+800	0	
10	+708	+703	+700	+3	-3
20	+599	+594	+600	-6	+9
30	+497	+492	+500	-8	+2
40	+406	+401	+400	+1	-9

*DVM Reading minus offset recorded in step 2.

- Record the DVM Reading for each 10 dB step of the step attenuator, up to 70 dB, in Table 4-13.
- Having recorded the DVM readings for all of the attenuator settings from 0 to 70 dB, subtract the AUX A Theoretical Reading from the Corrected DVM Reading (DVM reading minus offset) in each case and record results in Table 4-13. Theoretical Reading Subtracted From Corrected DVM Reading should not exceed ± 15 mV (± 1.5 dB).

PERFORMANCE TESTS

4-24. DISPLAY FIDELITY (Cont'd)

9. Subtract each converted reading (AUX A Theoretical Reading Subtracted From Corrected DVM Reading) from the previous converted reading. This subtraction must be performed algebraically. Record results in Table 4-13 (see Example).
10. The difference between adjacent readings (Table 4-13) should not exceed ± 10 mV (± 0.1 dB/dB).

Linear Display Accuracy

11. Replace 10 dB step attenuator with 1 dB step attenuator. Set step attenuator to 0 dB.
12. Set spectrum analyzer Amplitude Scale to LIN and RESOLUTION BW control to 1 MHz.
13. Peak the signal on the CRT display using the TUNING control. Set the signal generator OUTPUT LEVEL to place the trace at the top graticule line.
14. Set the step attenuator to 6 dB. Trace should be at 4th division above graticule baseline (center horizontal graticule line) ± 1.2 minor divisions (± 0.24 major divisions).

_____ div
15. Set the step attenuator to 12 dB. Trace should be at 2nd division above graticule baseline ± 1.2 minor divisions (± 0.24 major divisions).

_____ div

PERFORMANCE TESTS

4-25. CALIBRATOR ACCURACY

SPECIFICATION

Amplitude: $-30 \text{ dBm} \pm 1 \text{ dB}$.

002: $+20 \text{ dBmV} \pm 1 \text{ dB}$

Frequency: $280 \text{ MHz} \pm 300 \text{ MHz}$.

DESCRIPTION

The amplitude accuracy and frequency accuracy of the CAL OUTPUT signal are checked for $-30 \text{ dBm} \pm 1 \text{ dB}$ and $280 \text{ MHz} \pm 300 \text{ kHz}$, respectively.

002: $+20 \text{ dBmV} \pm 1 \text{ dB}$

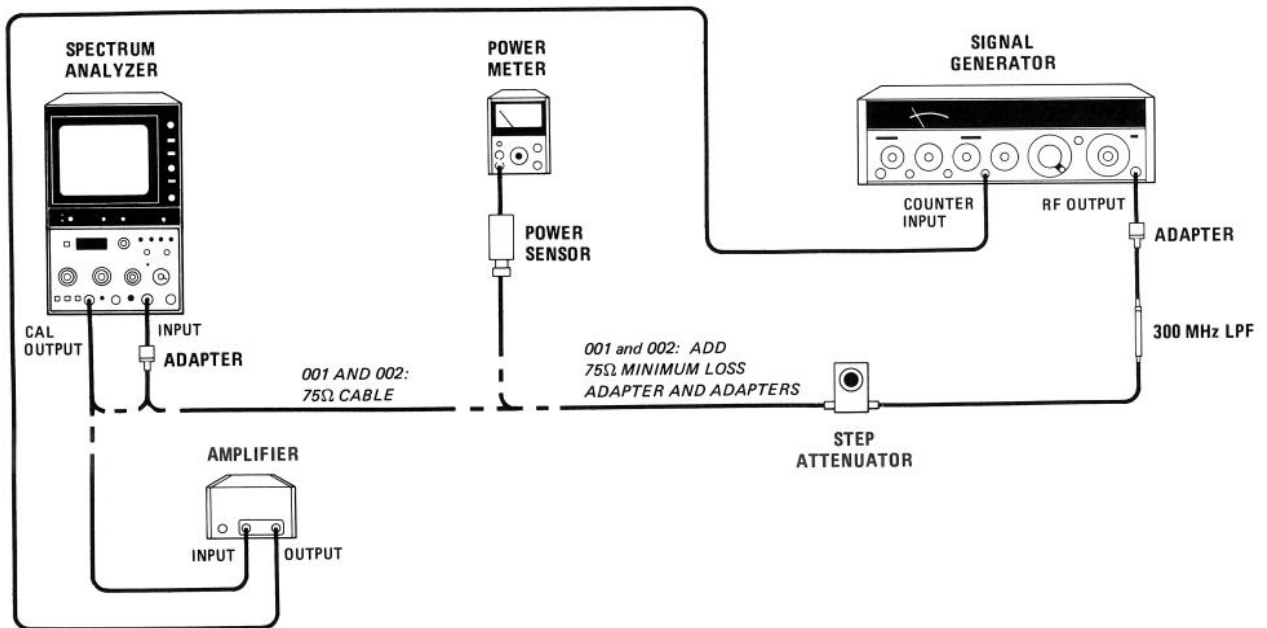

FIGURE 4-20. CALIBRATOR ACCURACY TEST SETUP

PERFORMANCE TESTS

4-25. CALIBRATOR ACCURACY (Cont'd)

EQUIPMENT

Amplifier	HP 8447D
Signal Generator	HP 8640B
10 dB Step Attenuator (Calibrated at 280 MHz)	HP 355D Opt. H82
Power Meter	HP 435B
300 MHz LPF	TELONIC TLP 300-4AB
Power Sensor	HP 8482A
Adapter, Type N (m) to BNC (f) (2 required)	HP 1250-0780
Adapter, Type N (f) to BNC (m)	HP 1250-0077
BNC Cable, 120 cm (48 in) (2 required)	HP 10503A

Additional Equipment, Options 001 and 002:

<i>Power Sensor, 75Ω</i>	<i>HP 8483A</i>
<i>Adapter, GR Type 874 to BNC (m), 75Ω</i>	<i>General Radio 0874-9754</i>
<i>Adapter, GR Type 874 to N (f), 75Ω</i>	<i>General Radio 0874-9751</i>
<i>Minimum Loss Adapter, 75Ω to 50Ω</i>	<i>HP 08558-60031</i>
<i>BNC Cable, 30 cm (12 in), 75Ω</i>	<i>HP 11652-60012</i>
<i>Adapter, SMA (f) to SMA (f)</i>	<i>HP 1250-1158</i>
<i>Adapter, BNC (f) to SMA (m)</i>	<i>HP 1250-1200</i>

PROCEDURE

1. Set spectrum analyzer controls as follows:

START – CENTER	CENTER
TUNING	280 MHz
FREQ SPAN/DIV	1 MHz
RESOLUTION BW	1 MHz
INPUT ATTEN	10 dB
REFERENCE LEVEL	-20 dBm
<i>002: +30 dBmV</i>	
Amplitude Scale	10 dB/DIV
SWEEP TIME/DIV	AUTO
SWEEP TRIGGER	FREE RUN
BASELINE CLIPPER	OFF

2. Set signal generator COUNTER MODE to EXT, 0–550, and EXPAND–X10. Connect spectrum analyzer CAL OUTPUT to signal generator COUNTER INPUT connector through amplifier. Frequency counter should indicate 280 MHz ± 300 kHz.

_____MHz

3. Set signal generator COUNTER MODE to INT and tune frequency to 280 MHz. Connect output of signal generator to calibrated step attenuator through 300 MHz low pass filter. Set signal generator OUTPUT LEVEL to 0 dBm.

 PERFORMANCE TESTS

4-25. CALIBRATOR ACCURACY (Cont'd)

4. Set step attenuator to 10 dB and connect power sensor and power meter to attenuator as shown in Figure 4-20.
5. Set signal generator OUTPUT LEVEL power for a -10 dBm reading on power meter. Leave signal generator set at this level.
6. Set step attenuator to 30 dB and connect output of step attenuator to spectrum analyzer INPUT connector.
7. Set spectrum analyzer TUNING control to center signal on CRT display. Peak amplitude of reference signal should be one division down from top graticule line.
8. Set Amplitude Scale switch to 1 dB/DIV and adjust REF LEVEL FINE control so peak amplitude of reference signal is one division down from top graticule line.
9. Disconnect reference signal and connect spectrum analyzer CAL OUTPUT to the INPUT connector. Signal peak amplitude should be one division down from top graticule line ± 1 division.

-31 dBm _____ -29 dBm

PROCEDURE FOR OPTIONS 001 AND 002:

1. Set spectrum analyzer controls as indicated above.
2. Connect CAL OUTPUT to 8640B counter input connector through amplifier. Frequency counter should indicate 280 MHz ± 300 kHz. (Use EXPAND X10 COUNTER MODE, EXT 0-550.)
3. Set signal generator frequency to 280 MHz. Connect output of signal generator to calibrated step attenuator and 75-ohm minimum loss adapter (approximately 5.7 dB attenuation). Set signal generator OUTPUT LEVEL to -5 dBm.
4. Set step attenuator to 0 dB. Connect minimum loss adapter through power sensor to power meter.
5. Set signal generator OUTPUT LEVEL for a -10 dBm (Option 001) or -8.75 dBm (Option 002) reading on power meter. Leave the signal generator set at this level.
6. Set step attenuator to 20 dB and connect -30 dBm ($+20$ dBmV) reference signal from signal generator through step attenuator, minimum loss adapter, and 75-ohm cable to HP 8558B INPUT 75 Ω connector.
7. With Amplitude Scale switch set to 10 dB/DIV, adjust TUNING control to center signal on CRT display. Peak amplitude of reference signal should be one division down from the top graticule line.

PERFORMANCE TESTS

4-25. CALIBRATOR ACCURACY (Cont'd)

8. *Set Amplitude Scale switch to 1 dB/DIV and adjust REF LEVEL FINE control so that peak amplitude of reference signal is on seventh graticule line (one division down from top).*
9. *Disconnect the reference signal and connect HP 8558B CAL OUTPUT through 75-ohm cable to INPUT 75Ω connector. Signal peak amplitude should be one division down from top, plus or minus one division.*

001: - 31 dBm _____ 29 dBm

002: + 19 dBmV _____ 21 dBmV

TABLE 4-15. PERFORMANCE TEST RECORD (1 OF 4)

Hewlett-Packard Company Model 8558B Spectrum Analyzer 0.1–1500 MHz Serial No. _____		Tested by _____ Date _____		
Paragraph Number	Test Description	Results		
		Min.	Actual	Max.
4-11.	Frequency Span Accuracy			
	3. 100 MHz FREQ SPAN/DIV	–0.4 div	_____	+0.4 div
	4. 50 MHz FREQ SPAN/DIV	–0.4 div	_____	+0.4 div
	5. 20 MHz FREQ SPAN/DIV	–0.4 div	_____	+0.4 div
	6. 10 MHz FREQ SPAN/DIV	–0.4 div	_____	+0.4 div
	7. 5 MHz FREQ SPAN/DIV	–0.4 div	_____	+0.4 div
	8. 2 MHz FREQ SPAN/DIV	–0.4 div	_____	+0.4 div
	9. 1 MHz FREQ SPAN/DIV	–0.4 div	_____	+0.4 div
	10. 500 kHz FREQ SPAN/DIV	–0.4 div	_____	+0.4 div
	13. 200 kHz FREQ SPAN/DIV	–0.4 div	_____	+0.4 div
	14. 100 kHz FREQ SPAN/DIV	–0.4 div	_____	+0.4 div
	50 kHz FREQ SPAN/DIV	–0.4 div	_____	+0.4 div
	20 kHz FREQ SPAN/DIV	–0.4 div	_____	+0.4 div
	10 kHz FREQ SPAN/DIV	–0.4 div	_____	+0.4 div
5 kHz FREQ SPAN/DIV	–0.4 div	_____	+0.4 div	
4-12.	TUNING Accuracy			
	5. 10.0 MHz	–5.2 div (8.96 MHz)	_____	+5.2 div (11.04 MHz)
	6. 20.0 MHz	–5.2 div (18.96 MHz)	_____	+5.2 div (21.04 MHz)
	40.0 MHz	–5.2 div (38.96 MHz)	_____	+5.2 div (41.04 MHz)
	60.0 MHz	–5.2 div (58.96 MHz)	_____	+5.2 div (61.04 MHz)
	80.0 MHz	–5.2 div (78.96 MHz)	_____	+5.2 div (81.04 MHz)
	100.0 MHz	–5.2 div (96.96 MHz)	_____	+5.2 div (101.04 MHz)
	120.0 MHz	–5.2 div (118.96 MHz)	_____	+5.2 div (121.04 MHz)
	140.0 MHz	–5.2 div (138.96 MHz)	_____	+5.2 div (141.04 MHz)
	160.0 MHz	–5.2 div (158.96 MHz)	_____	+5.2 div (161.04 MHz)
	180.0 MHz	–5.2 div (178.96 MHz)	_____	+5.2 div (181.04 MHz)
	200 MHz	–5.2 div (194.8 MHz)	_____	+5.2 div (205.2 MHz)

TABLE 4-15. PERFORMANCE TEST RECORD (2 OF 4)

Paragraph Number	Test Description	Results		
		Min.	Actual	Max.
4-12.	TUNING Accuracy (Cont'd)			
	400 MHz	-5.2 div (394.8 MHz)	_____	+5.2 div (405.2 MHz)
	600 MHz	-5.2 div (594.8 MHz)	_____	+5.2 div (605.2 MHz)
	800 MHz	-5.2 div (794.8 MHz)	_____	+5.2 div (805.2 MHz)
	1000 MHz	-5.2 div (994.8 MHz)	_____	+5.2 div (1005.2 MHz)
	1200 MHz	-5.2 div (1194.8 MHz)	_____	+5.2 div (1205.2 MHz)
	1400 MHz	-5.2 div (1394.8 MHz)	_____	+5.2 div (1405.2 MHz)
	1500 MHz	-5.2 div (1494.8 MHz)	_____	+5.2 div (1505.2 MHz)
4-13.	Residual FM 6. Peak-to-Peak Variation of Trace		_____	1.0 div (1 kHz/0.1 sec)
4-14.	Noise Sidebands 6. Noise Sidebands		_____	6.5 div down (-65 dB)
4-15.	Resolution Bandwidth Accuracy			
	7. 3 MHz Resolution BW	2.40 MHz	_____	3.60 MHz
	8. 1 MHz Resolution BW	800 kHz	_____	1.20 MHz
	9. 300 kHz Resolution BW	240 kHz	_____	360 kHz
	10. 100 kHz Resolution BW	80 kHz	_____	120 kHz
	17. 30 kHz Resolution BW	24 kHz	_____	36 kHz
	18. 10 kHz Resolution BW	8 kHz	_____	12 kHz
19. 3 kHz Resolution BW	2.4 kHz	_____	3.6 kHz	
20. 1 kHz Resolution BW	0.8 kHz	_____	1.2 kHz	
4-16.	Resolution Bandwidth Selectivity			
	24. 3 MHz Resolution BW Selectivity		_____	15:1
	1 MHz Resolution BW Selectivity		_____	15:1
	300 kHz Resolution BW Selectivity		_____	15:1
	100 kHz Resolution BW Selectivity		_____	15:1
	30 kHz Resolution BW Selectivity		_____	15:1
	10 kHz Resolution BW Selectivity		_____	15:1
	3 kHz Resolution BW Selectivity		_____	15:1
1 kHz Resolution BW Selectivity		_____	15:1	

TABLE 4-15. PERFORMANCE TEST RECORD (3 OF 4)

Paragraph Number	Test Description	Results		
		Min.	Actual	Max.
4-17.	Average Noise Level			
	2. Average Noise Level 1 MHz to 1000 MHz		_____	-107 dBm
	3. Average Noise Level 500 MHz to 1500 MHz		_____	-107 dBm
	5. Average Noise Level 1 MHz to 11 MHz		_____	-107 dBm
	001: Max. is -100 dBm			
	002: Max. is -53 dBmV			
4-18.	Spurious Responses			
	9. Harmonic Distortion			
	2nd Harmonic	-70 dB	_____	
	3rd Harmonic	-70 dB	_____	
	18. Third Order Intermodulation Distortion, 30 MHz input signals	-70 dB	_____	
	20. Second Order Intermodulation Distortion, 30 MHz input signals ($f_2 - f_1$)	-70 dB	_____	
	22. Second Order Intermodulation Distortion, 30 MHz input signals ($f_1 + f_2$)	-70 dB	_____	
	27. Third Order Intermodulation Distortion, 4 MHz input signals	-60 dB	_____	
	29. Second Order Intermodulation Distortion, 4 MHz input signals ($f_2 - f_1$)	-60 dB	_____	
	30. Second Order Intermodulation Distortion, 4 MHz input signals ($f_1 + f_2$)	-60 dB	_____	
4-19.	Residual Responses			
	11. Residual Responses 1 MHz to 1000 MHz		_____	-100 dBm
	17. Residual Responses 500 MHz to 1500 MHz		_____	-100 dBm
	001: Max. is <-95 dBm			
	002: Max. is <-50 dBmV			
4-20.	Frequency Response			
	17. Frequency Response		_____	2.0 dB
4-21.	Bandwidth Switching (Amplitude Variation)			
	6. 3 MHz to 300 kHz (overall variation)	-0.5 dB	_____	+0.5 dB
	3 MHz to 1 kHz (overall variation)	-1.0 dB	_____	+1.0 dB
4-22.	Input Attenuator Accuracy			
	4. Error Between Adjacent Settings		_____	±0.5 dB (1.0 dB)
	5. Error Over Full 70 dB Range		_____	±1.0 dB (2.0 dB)

TABLE 4-15. PERFORMANCE TEST RECORD (4 OF 4)

Paragraph Number	Test Description	Results		
		Min.	Actual	Max.
4-23.	Reference Level Accuracy			
	4. Step Accuracy in Log -10 dBm to -80 dBm		_____	±0.5 dB (1.0 dB)
	-10 dBm to -100 dBm		_____	±1.0 dB (2.0 dB)
	002: +40 dBmV to -30 dBmV +40 dBmV to -50 dBmV			
	8. Step Accuracy in LIN -10 dBm to -80 dBm		_____	±0.5 dB (1.0 dB)
	-10 dBm to -100 dBm		_____	±1.0 dB (2.0 dB)
	002: +40 dBmV to -30 dBmV +40 dBmV to -50 dBmV			
	11. Vernier Accuracy REF LEVEL FINE:			
	-1	-0.5 dB	_____	+0.5 dB
	-2	-0.5 dB	_____	+0.5 dB
	-3	-0.5 dB	_____	+0.5 dB
	-4	-0.5 dB	_____	+0.5 dB
	-5	-0.5 dB	_____	+0.5 dB
	-6	-0.5 dB	_____	+0.5 dB
-7	-0.5 dB	_____	+0.5 dB	
-8	-0.5 dB	_____	+0.5 dB	
-9	-0.5 dB	_____	+0.5 dB	
-10	-0.5 dB	_____	+0.5 dB	
-11	-0.5 dB	_____	+0.5 dB	
-12	-0.5 dB	_____	+0.5 dB	
4-24.	Display Fidelity			
	Log Display Accuracy			
	8. Maximum Error Over Full 70 dB Display Range		_____	±1.5 dB (±15 mV)
	10. Error Between Adjacent Readings		_____	±1.0 dB (±10 mV)
	Linear Display Accuracy			
14. Error at 4th division	3.76 div	_____	4.24 div	
15. Error at 2nd division	1.76 div	_____	2.24 div	
4-25.	Calibrator Accuracy			
	2. CAL OUTPUT Frequency	279.7 MHz	_____	280.3 MHz
	9. CAL OUTPUT Amplitude 002: Min. is +19 dBmV, Max. is +21 dBmV	-31 dBm	_____	-29 dBm

SECTION V ADJUSTMENTS

5-1. INTRODUCTION

5-2. The adjustments in this section are required to optimize spectrum analyzer performance after repair. Table 5-2 lists adjustable components by adjustment name, reference designation, adjustment paragraph, and description.

5-3. Data taken during adjustment should be recorded in the spaces provided. Comparison of initial data with data taken during periodic adjustments is useful for preventive maintenance and troubleshooting.

WARNING

The adjustments in this section require the spectrum analyzer to be removed from the display mainframe and connected through an extender cable assembly. Be very careful; the energy at some points in the instrument might, if contacted, cause personal injury. The adjustments in this section should be performed only by a skilled person who knows the hazard involved.

NOTE

Before performing any adjustments, allow one hour warmup time.

5-4. EQUIPMENT REQUIRED

5-5. The table of Recommended Test Equipment in Section I lists the test equipment and test accessories required in the adjustment procedures. In addition, the table lists the required minimum specifications and suggested manufacturers' model numbers.

5-6. Required service accessories, with part numbers, are illustrated in Section I.

TABLE 5-1. ADJUSTMENTS

Paragraph	Adjustment
5-17	Second Converter LO and Bandpass Adjustments
5-18	Third Converter LO and CAL Output Adjustment
5-19	Slope Adjustment
5-20	Second IF Bandpass Amplifier and Bandpass Filter Adjustment
5-21	Crystal and LC Bandwidth Filter Adjustment
5-22	3-dB Bandwidth Adjustment
5-23	Step Gain Assembly RF Gain Adjustment
5-24	Step Amplifier Gain Adjustments
5-25	+ 19.5V Adjustment
5-26	Log Amplifier Log and Linear Adjustment
5-27	Sweep Time Per Division Adjustment
5-28	Frequency Control and DPM Adjustments
5-29	1 dB Offset Adjustment

5-7. Adjustment Tools

5-8. For adjustments requiring a non-metallic tuning tool, use fiber tuning tool, HP Part Number 8170-0033. Never try to force an adjustment control in the analyzer. This is especially critical when tuning slug-tuned inductors and variable capacitors.

5-9. Extender Cable Installation

WARNING

Disconnect mainframe line cord before installing extender cable assembly.

5-10. Pull out the lock knob and slide the spectrum analyzer out of the display mainframe. If side stops are installed, refer to Section II for removal.

5-11. Carefully slide the extender cable assembly, HP Part Number 5060-0303, into the display mainframe, aligning the metal guide plate with the slotted side rails of the mainframe. Firmly seat the extender cable assembly to ensure good contact.

5-12. Connect the opposite end of the cable to the spectrum analyzer. The plug is keyed so it will go on correctly and will not make contact upside-down. Remove the orange and the yellow leads from pins 3 and 4 on the A15 board at the rear of the spectrum analyzer. Connect the corresponding leads from the extender cable assembly to these pins by means of the insulated alligator clips.

5-13. RELATED ADJUSTMENTS

5-14. These adjustments should be performed whenever troubleshooting information in Section VIII indicates that an adjustable circuit is not operating properly. Perform the adjustments after repair or replacement of the circuit. The troubleshooting procedures and Table 5-2 specify the required adjustments.

5-15. FACTORY-SELECTED COMPONENTS

5-16. Table 5-3 provides a list of factory-selected components by reference designation, selection procedure paragraph number, range of values, and basis of selection. Factory-selected components are designated by an asterisk (*) on the schematic diagrams in Section VIII and in the Replaceable Parts tables. Part numbers for standard-value components can be found in Table 5-4.

TABLE 5-2. ADJUSTABLE COMPONENTS (1 OF 4)

Adjustment Name	Reference Designator	Adjustment Paragraph	Description
REF	A1A2R3	5-28	Adjusts DPM reference voltage and adjusts frequency for correct FREQUENCY MHz readout at 1500 MHz.
2nd MIXER MATCH	A5L2	5-17	Adjust for optimum match between second converter output and second IF input.
Z1, Z2, Z3	A5Z1 - A5Z3	5-17	Adjust the bandpass of the 2050 MHz bandpass filter.
2nd LO FREQUENCY	A5Z4	5-17	Adjusts second LO frequency to 1748.60 MHz.
3.55 GHZ	A7R1	5-28	Coarse adjustment of YIG upper frequency limit, 3.55 GHz.
3.55 FINE	A7R2	5-28	Fine adjustment of YIG upper frequency limit, 3.55 GHz.
2.0 GHZ	A7R3	5-28	Adjusts YIG lower frequency limit, 2.05 GHz
REF V	A7R4	5-28	Adjusts reference voltage to 6.0 volts and is fine adjustment of YIG lower frequency limit, 2.05 GHz.
+14.5V	A7R5	5-28	Adjusts 14.5 volt supply to +14.5 volts.
FM	A7R6	5-28	Adjusts frequency span accuracy for frequency spans ≤ 1 MHz per division.
GAIN	A7R7	5-28	Adjusts frequency for correct DPM frequency readout at 190.0 MHz.
RNG	A7R8	5-28	Adjusts frequency control circuit for proper DPM ranging.
OFS	A7R72	5-28	Adjusts frequency for correct FREQUENCY MHz readout at 200 MHz.
5 ms	A8R13	5-27	Adjusts sweep ramp to calibrate 5 ms per division sweep time.
1 ms	A8R10	5-27	Adjusts sweep ramp to calibrate 1 ms per division sweep time.
+10V	A8R2	5-27	Adjusts +10 volt supply. This adjustment must be performed while spectrum analyzer is still cold, during first five minutes after turn on.
XTL	A8R72	5-21 5-22	Adjusts IF bandwidth between 3 dB points for RESOLUTION BW setting of 3 kHz.
LC	A8R85	5-21	Adjusts IF bandwidth between 3 dB points for RESOLUTION BW setting of 1 MHz.
LO FREQ	A9L4	5-18	Adjusts third converter 280 MHz crystal-controlled LO for maximum output.

TABLE 5-2. ADJUSTABLE COMPONENTS (2 OF 4)

Adjustment Name	Reference Designator	Adjustment Paragraph	Description
SLOPE COMP	A9R1	5-19	Compensates for frequency response of input mixer, allowing flatness of less than 2 dB.
3rd LO PWR	A9R5	5-18	Adjusts CAL OUTPUT signal for -30 dBm power level. <i>002: +20 dBmV.</i>
C1, C2, C3	A10C1 - A10C3	5-20	Adjust the bandpass of the Second IF assembly Bandpass Filter (301.4 MHz).
2nd IF TUNING	A10L2	5-20	Peaks second IF bandpass amplifier. Has very little effect on signal.
SYM	A11C15	5-21	Adjust symmetry of first stage of crystal bandwidth filter.
LC CTR	A11C23	5-21	Adjusts centering of first stage of LC bandwidth filter.
CTR	A11C25	5-21	Adjusts centering of first stage of crystal bandwidth filter.
SYM	A11C38	5-21	Adjusts symmetry of second stage of crystal bandwidth filter.
LC CTR	A11C45	5-21	Adjusts centering of second stage of LC bandwidth filter.
CTR	A11C54	5-21	Adjusts centering of second stage of crystal bandwidth filter.
C73	A11C73	5-21	Compensates for capacitance of CR3.
C74	A11C74	5-21	Compensates for capacitance of CR11.
LC	A11R26	5-21	Adjusts feedback in LC circuit of bandpass filter.
XTL	A11R31	5-21	Adjusts feedback in crystal circuit of bandpass filter.
40 dB	A12R1	5-24	Adjusts 40 dB step gain.
20 dB	A12R2	5-24	Adjusts 20 dB step gain.
10 dB	A12R3	5-24	Adjusts 10 dB step gain.
GAIN	A12R4	5-23	Adjusts overall gain of Step Gain assembly.
0 dB	A12R5	5-24	Adjusts to calibrate 0 dB position of REF LEVEL FINE control.

TABLE 5-2. ADJUSTABLE COMPONENTS (3 OF 4)

Adjustment Name	Reference Designator	Adjustment Paragraph	Description
-12 dB	A12R6	5-24	Adjusts to calibrate -12 dB position of REF LEVEL FINE control.
+19.5V	A12R7	5-25	Adjusts +19.5 volt supply.
SYM	A13C15	5-21	Adjusts symmetry of first stage of crystal bandwidth filter.
LC CTR	A13C23	5-21	Adjusts centering of first stage of LC bandwidth filter.
CTR	A13C25	5-21	Adjusts centering of first stage of crystal bandwidth filter.
SYM	A13C38	5-21	Adjusts symmetry of second stage of crystal bandwidth filter.
LC CTR	A13C45	5-21	Adjusts centering of second stage of LC bandwidth filter.
CTR	A13C54	5-21	Adjusts centering of second stage of crystal bandwidth filter.
C73	A13C73	5-21	Compensate for capacitance of CR3.
C74	A13C74	5-21	Compensates for capacitance of CR11.
LC	A13R26	5-21	Adjusts feedback in LC circuit of bandpass filter.
XTL	A13R31	5-21	Adjusts feedback in crystal circuit of bandpass filter.
OFFSET	A14R10	5-26	Adjusts -8V temperature compensated supply.
TC	A14R21		Adjusts gain of +1V supply to provide temperature compensation for log mode temperature controlled variable gain amplifier. (Factory adjustable only.)
SLOPE	A14R23	5-26	Adjusts gain of log mode temperature controlled gain amplifier.
G6	A14R27	5-26	Adjusts combined gain of 2nd and 3rd stages in linear mode.
G5	A14R30	5-26	Adjusts gain of 4th stage in linear mode.
G4	A14R33	5-26	Adjusts gain of 5th stage in linear mode.

TABLE 5-2. ADJUSTABLE COMPONENTS (4 OF 4)

Adjustment Name	Reference Designator	Adjustment Paragraph	Description
LIN	A14R34	5-26	Adjusts combined gain of 6th and 7th stages in linear mode.
-10 dB	A14R39	5-26	Adjusts shape of log fidelity curve at -10 dB.
-30 dB	A14R69	5-26	Adjusts shape of log fidelity curve at -30 dB.
1 VT	A14R88		Adjusts voltage at A14TP1 for approximately +1V. (Factory adjustable only.)
LOG GAIN	A14R121	5-26	Adjusts dc offset circuitry at output of A14 Log Amplifier Assembly for 10 dB steps in log mode.
1 dB OFFSET	A15R1	5-29	Adjusts for equal amplitude displayed at full screen in 10 dB/DIV and 1 dB/DIV for a given input.

TABLE 5-3. FACTORY-SELECTED COMPONENTS IN ALPHA-NUMERICAL ORDER

Reference Designator	Selection Procedure Paragraph Number	Basis of Selection
A7R62		Selected to shift adjustment range of R2.
A7R66		Selected to shift adjustment range of R1.
A7R71		Selected to shift adjustment range of R3.
A8R42		Selected to set start of sweep ramp to $-5.000V \pm 30\text{ mV}$.
A8R47		Selected to set high end of sweep ramp to $+5V$.
A8R68		Selected for 0V at A8TP8 with START-CENTER switch in START, MHz/DIV, single scan mode (no sweep).
A8R109		Selected to optimize 1 kHz bandwidth.
A8R110		Selected to optimize 3 kHz bandwidth.
A8R111	5-22	Selected to optimize 10 kHz bandwidth.
A8R116	5-22	Selected to optimize 300 kHz bandwidth.
A8R118		Selected to optimize 1 MHz bandwidth.
A8R120	5-22	Selected to optimize 3 MHz bandwidth.
A9R4	5-18	Selected for proper Third Converter LO power.
A9R9		Selected for proper CAL OUTPUT power.
A9R12		Selected for proper gain of Third Converter.
A9R14		Selected for proper REF LEVEL CAL range.
A11C20, C16		Selected to shift adjustment range of A11C23. C16 must be the same value as C20.
A11C43, 64		Selected to shift adjustment range of A11C45. C43 must be the same value as C64.
A11R7		Adjusts XTAL bandwidth amplitudes relative to LC amplitudes.
A11R19	5-22	Selected to give correct IF bandwidth for RESOLUTION BW of 100 kHz.
A11R23	5-22	Selected to give correct IF bandwidth for RESOLUTION BW of 30 kHz.
A11R43	5-22	Selected to give correct IF bandwidth for RESOLUTION BW of 100 kHz.
A11R48	5-22	Selected to give correct IF bandwidth for RESOLUTION BW of 30 kHz.
A11R56		Selected to equalize feedback between LC stages (not field-selectable).
A13C20		Selected to shift adjustment range of A13C23.
A13C44		Selected to shift adjustment range of A13C45.
A13R19	5-22	Selected to give correct IF bandwidth for RESOLUTION BW of 100 kHz.
A13R23	5-22	Selected to give correct IF bandwidth for RESOLUTION BW of 30 kHz.
A13R43	5-22	Selected to give correct IF bandwidth for RESOLUTION BW of 100 kHz.
A13R48	5-22	Selected to give correct IF bandwidth for RESOLUTION BW of 30 kHz.
A13R56		Selected to equalize feedback between LC stages (not field-selectable).
A14R93		Selected to shift adjustment range of A14R34.
A14R101		Selected to shift adjustment range of A14R34.
A14R107		Selected to shift adjustment range of A14R23.
A15R26		Selected to provide increased range adjustment for 1 dB offset circuit.
A17R1		Selected for proper voltage offset of A17Q1 and A17Q2 to ensure initial turn-on of oscillator.

TABLE 5-4. HP PART NUMBERS OF STANDARD VALUE REPLACEMENT COMPONENTS (1 OF 3)



CAPACITORS					
RANGE: 1 to 24 pF TYPE: Tubular TOLERANCE: 1 to 9.1 pF = ± 0.25 pF 10 to 24 pF = $\pm 5\%$			RANGE: 27 to 680 pF TYPE: Dipped Mica TOLERANCE: $\pm 5\%$		
					
Value (pF)	HP Part Number	C D	Value (pF)	HP Part Number	C D
1.0	0160-2236	8	27	0160-2306	3
1.2	0160-2237	9	30	0160-2199	2
1.5	0150-0091	8	33	0160-2150	5
1.8	0160-2239	1	36	0160-2308	5
2.0	0160-2240	4	39	0140-0190	7
2.2	0160-2241	5	43	0160-2200	6
2.4	0160-2242	6	47	0160-2307	4
2.7	0160-2243	7	51	0160-2201	7
3.0	0160-2244	8	56	0140-0191	8
3.3	0150-0059	8	62	0140-0205	5
3.6	0160-2246	0	68	0140-0192	9
3.9	0160-2247	1	75	0160-2202	8
4.3	0160-2248	2	82	0140-0193	0
4.7	0160-2249	3	91	0160-2203	9
5.1	0160-2250	6	100	0160-2204	0
5.6	0160-2251	7	110	0140-0194	1
6.2	0160-2252	8	120	0160-2205	1
6.8	0160-2253	9	130	0140-0195	2
7.5	0160-2254	0	150	0140-0196	3
8.2	0160-2255	1	160	0160-2206	2
9.1	0160-2256	2	180	0140-0197	4
10.0	0160-2257	3	200	0140-0198	5
11.0	0160-2258	4	220	0160-0134	1
12.0	0160-2259	5	240	0140-0199	6
13.0	0160-2260	8	270	0140-0210	2
15.0	0160-2261	9	300	0160-2207	3
16.0	0160-2262	0	330	0160-2208	4
18.0	0160-2263	1	360	0160-2209	5
20.0	0160-2264	2	390	0140-0200	0
22.0	0160-2265	3	430	0160-0939	4
24.0	0160-2266	4	470	0160-3533	0
			510	0160-3534	1
			560	0160-3535	2
			620	0160-3536	3
			680	0160-3537	4

TABLE 5-4. HP PART NUMBERS OF STANDARD VALUE REPLACEMENT COMPONENTS (2 OF 3)

RESISTORS								
RANGE: 10 to 464K Ohms TYPE: Fixed-Film WATTAGE: .125 at 125°C TOLERANCE: ±1.0%								
Value (Ω)	HP Part Number	C D	Value (Ω)	HP Part Number	C D	Value (Ω)	HP Part Number	C D
10.0	0757-0346	2	464	0698-0082	7	21.5K	0757-0199	3
11.0	0757-0378	0	511	0757-0416	7	23.7K	0698-3158	4
12.1	0757-0379	1	562	0757-0417	8	26.1K	0698-3159	5
13.3	0698-3427	0	619	0757-0418	9	28.7K	0698-3449	6
14.7	0698-3428	1	681	0757-0419	0	31.6K	0698-3160	8
16.2	0757-0382	6	750	0757-0420	3	34.8K	0757-0123	3
17.8	0757-0294	9	825	0757-0421	4	38.3K	0698-3161	9
19.6	0698-3429	2	909	0757-0422	5	42.2K	0698-3450	9
21.5	0698-3430	5	1.0K	0757-0280	3	46.4K	0698-3162	0
23.7	0698-3431	6	1.1K	0757-0424	7	51.1K	0757-0458	7
26.1	0698-3432	7	1.21K	0757-0274	5	56.2K	0757-0459	8
28.7	0698-3433	8	1.33K	0757-0317	7	61.9K	0757-0460	1
31.6	0757-0180	2	1.47K	0757-1094	9	68.1K	0757-0461	2
34.8	0698-3434	9	1.62K	0757-0428	1	75.0K	0757-0462	3
38.3	0698-3435	0	1.78K	0757-0278	9	82.5K	0757-0463	4
42.2	0757-0316	6	1.96K	0698-0083	8	90.9K	0757-0464	5
46.4	0698-4037	0	2.15K	0698-0084	9	100K	0757-0465	6
51.1	0757-0394	0	2.37K	0698-3150	6	110K	0757-0466	7
56.2	0757-0395	1	2.61K	0698-0085	0	121K	0757-0467	8
61.9	0757-0276	7	2.87K	0698-3151	7	133K	0698-3451	0
68.1	0757-0397	3	3.16K	0757-0279	0	147K	0698-3452	1
75.0	0757-0398	4	3.48K	0698-3152	8	162K	0757-0470	3
82.5	0757-0399	5	3.83K	0698-3153	9	178K	0698-3243	8
90.9	0757-0400	9	4.22K	0698-3154	0	196K	0698-3453	2
100	0757-0401	0	4.64K	0698-3155	1	215K	0698-3454	3
110	0757-0402	1	5.11K	0757-0438	3	237K	0698-3266	5
121	0757-0403	2	5.62K	0757-0200	7	261K	0698-3455	4
133	0698-3437	2	6.19K	0757-0290	5	287K	0698-3456	5
147	0698-3438	3	6.81K	0757-0439	4	316K	0698-3457	6
162	0757-0405	4	7.50K	0757-0440	7	348K	0698-3458	7
178	0698-3439	4	8.25K	0757-0441	8	383K	0698-3459	8
196	0698-3440	7	9.09K	0757-0288	1	422K	0698-3460	1
215	0698-3441	8	10.0K	0757-0442	9	464K	0698-3260	9
237	0698-3442	9	11.0K	0757-0443	0			
261	0698-3132	4	12.1K	0757-0444	1			
287	0698-3443	0	13.3K	0757-0289	2			
316	0698-3444	1	14.7K	0698-3156	2			
348	0698-3445	2	16.2K	0757-0447	4			
383	0698-3446	3	17.8K	0698-3136	8			
422	0698-3447	4	19.6K	0698-3157	3			

TABLE 5-4. HP PART NUMBERS OF STANDARD VALUE REPLACEMENT COMPONENTS (3 OF 3)

RESISTORS											
RANGE: 10 to 1.47M Ohms TYPE: Fixed-Film WATTAGE: .5 at 125°C TOLERANCE: ±1%											
Value (Ω)	HP Part Number	C D	Value (Ω)	HP Part Number	C D	Value (Ω)	HP Part Number	C D	Value (Ω)	HP Part Number	C D
10.0	0757-0984	4	215	0698-3401	0	4.64K	0698-3348	4	110K	0757-0859	2
11.0	0575-0985	5	237	0698-3102	8	5.11K	0757-0833	2	121K	0757-0860	5
12.1	0757-0986	6	261	0757-1090	5	5.62K	0757-0834	3	133K	0757-0310	0
13.3	0757-0001	6	287	0757-1092	7	6.19K	0757-0196	0	147K	0698-3175	5
14.7	0698-3388	2	316	0698-3402	1	6.81K	0757-0835	4	162K	0757-0130	2
16.2	0757-0989	9	348	0698-3403	2	7.50K	0757-0836	5	178K	0757-0129	9
17.8	0698-3389	3	383	0698-3404	3	8.25K	0757-0837	6	196K	0757-0063	0
19.6	0698-3390	6	422	0698-3405	4	9.09K	0757-0838	7	215K	0757-0127	7
21.5	0698-3391	7	464	0698-0090	7	10.0K	0757-0839	8	237K	0698-3424	7
23.7	0698-3392	8	511	0757-0814	9	12.1K	0757-0841	2	261K	0757-0064	1
26.1	0757-0003	8	562	0757-0815	0	13.3K	0698-3413	4	287K	0757-0154	0
28.7	0698-3393	9	619	0757-0158	4	14.7K	0698-3414	5	316K	0698-3425	8
31.6	0698-3394	0	681	0757-0816	1	16.2K	0757-0844	5	348K	0757-0195	9
34.8	0698-3395	1	750	0757-0817	2	17.8K	0698-0025	8	383K	0757-0133	5
38.3	0698-3396	2	825	0757-0818	3	19.6K	0698-3415	6	422K	0757-0134	6
42.2	0698-3397	3	909	0757-0819	4	21.5K	0698-3416	7	464K	0698-3426	9
46.4	0698-3398	4	1.00K	0757-0159	5	23.7K	0698-3417	8	511K	0757-0135	7
51.1	0757-1000	7	1.10K	0757-0820	7	26.1K	0698-3418	9	562K	0757-0868	3
56.2	0757-1001	8	1.21K	0757-0821	8	28.7K	0698-3103	9	619K	0757-0136	8
61.9	0757-1002	9	1.33K	0698-3406	5	31.6K	0698-3419	0	681K	0757-0869	4
68.1	0757-0794	4	1.47K	0757-1078	9	34.8K	0698-3420	3	750K	0757-0137	9
75.0	0757-0795	5	1.62K	0757-0873	0	38.3K	0698-3421	4	825K	0757-0870	7
82.5	0757-0796	6	1.78K	0698-0089	4	42.2K	0698-3422	5	909K	0757-0138	0
90.0	0757-0797	7	1.96K	0698-3407	6	46.4K	0698-3423	6	1M	0757-0059	4
100	0757-0198	2	2.15K	0698-3408	7	51.1K	0757-0853	6	1.1M	0757-0139	1
110	0757-0798	8	2.37K	0698-3409	8	56.2K	0757-0854	7	1.21M	0757-0871	8
121	0757-0799	9	2.61K	0698-0024	7	61.9K	0757-0309	7	1.33M	0757-0194	8
133	0698-3399	5	2.87K	0698-3101	7	68.1K	0757-0855	8	1.47M	0698-3464	5
147	0698-3400	9	3.16K	0698-3410	1	75.0K	0757-0856	9			
162	0757-0802	5	3.48K	0698-3411	2	82.5K	0757-0857	0			
178	0698-3334	8	3.83K	0698-3412	3	90.9K	0757-0858	1			
196	0757-1060	9	4.22K	0698-3346	2	100K	0757-0367	7			

TABLE 5-5. RELATED ADJUSTMENTS

Assembly Changed or Repaired		Perform the Following Related Adjustments	Paragraph Number
A1	Digital Panel Meter	A1A2R3	5-28
A2	Front Switch	A12R5, A12R6	5-24
A3	Input Attenuator	No related adjustments	
A4	First Converter	A9R1	5-19
A5	Second Converter	A5Z1, A5Z2, A5Z3, A5Z4, A5L2	5-17
A6	YIG Oscillator	A1A2R3, A7R1, A7R2, A7R3, A7R4, A7R6, A7R7, A7R8, A7R72	5-28
A7	Frequency Control	A5Z4 A1A2R3, A7R1, A7R2, A7R3, A7R4, A7R5, A7R6, A7R7, A7R72	5-17 5-28
A8	Sweep Generator	A8R2, A8R10, A8R13, A8R72, A8R85	5-22, 5-27
A9	Third Converter	A9L4, A9R5, A9R1	5-18, 5-19
A10	Second IF	A10C1, A10C2, A10C3, A10L2	5-20
A11, A13*	Bandwidth Filters	A11C15, A11C23, A11C25, A11C38, A11C45, A11C54, A11C73, A11C74, A13C15, A13C23, A13C25, A13C38, A13C45, A13C54, A13C73, A13C74, A8R72, A8R85	5-21, 5-22
A12	Step Gain	A12R1, A12R2, A12R3, A12R4, A12R5, A12R6, A12R7	5-23 – 5-25
A14	Log Amplifier	A14R23, A14R27, A14R30, A14R33, A14R34, A14R39, A14R69, A14R121	5-26 5-29
A15	Vertical Driver and Blanking	A15R1	5-29
A16	Motherboard	No related adjustments	
A17	Inverter	No related adjustments	

*A11 and A13 bandwidth filter assemblies contain a matched set of crystals. These two assemblies must be treated as a matched pair when replacement is necessary.

ADJUSTMENTS

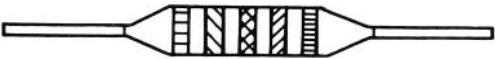
5-17. SECOND CONVERTER LO AND BANDPASS ADJUSTMENTS

REFERENCE

A5 Schematic

DESCRIPTION

The second converter is adjusted for 1748.60 MHz and the bandpass filter is adjusted for a 2050 MHz Bandpass.

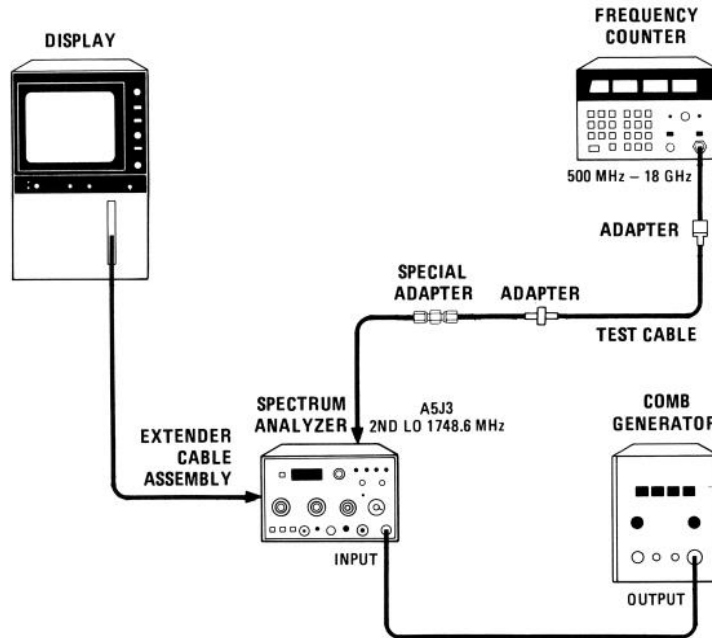

FIGURE 5-1. SECOND CONVERTER LO AND BANDPASS ADJUSTMENT TEST SETUP

EQUIPMENT

Frequency Counter	HP 5342A
Comb Generator	HP 8406A
Test Cable, SMC (f) to BNC (m)	HP 11592-60001
Adapter, SMC (m) to SMC (m)	HP 1250-0827
Adapter, Type N (m) to BNC (f)	HP 1250-0780
Special Adapter	See Figure 5-2
BNC Cable 120 cm (48 in)	HP 10503A
Extender Cable Assembly	HP 5060-0303

Additional Equipment, Options 001 and 002:

<i>Minimum Loss Adapter, 75Ω to 50Ω</i>	<i>HP 08558-60031</i>
<i>BNC Cable, 30 cm (12 in), 75Ω</i>	<i>HP 11652-60012</i>
<i>Adapter, SMA (f) to SMA (f)</i>	<i>HP 1250-1158</i>
<i>Adapter, BNC (f) to SMA (m)</i>	<i>HP 1250-1200</i>

ADJUSTMENTS

5-17. SECOND CONVERTER LO AND BANDPASS ADJUSTMENTS (Cont'd)

NOTE

The special adapter in Figure 5-1 is made from a SMC (f) to SMC (f) adapter, HP Part No. 1250-1113. The nuts must be soldered to the body of the subminiature RF adapter so they will both turn with the body. Be sure to space the nuts properly before soldering (see Figure 5-2).

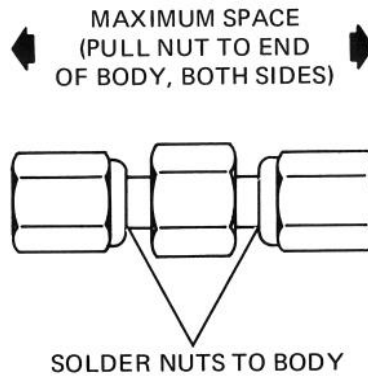

FIGURE 5-2. SPECIAL ADAPTER USED IN SECOND CONVERTER LO AND BANDPASS TEST SETUP

PROCEDURE

1. Set equipment as follows:

Spectrum Analyzer

START - CENTER.....	CENTER
TUNING.....	300 MHz
FREQ SPAN/DIV.....	100 MHz
RESOLUTION BW.....	1 MHz (optimum)
INPUT ATTEN.....	0 dB
REFERENCE LEVEL.....	-30 dBm
002: +20 dBmV	
Amplitude Scale.....	10 dB/DIV
SWEEP TIME/DIV.....	AUTO
SWEEP TRIGGER.....	FREE RUN

Frequency Counter

10 Hz – 500 MHz/500 MHz – 18 GHz.....	500 MHz – 18 GHz
SAMPLE RATE.....	Full counterclockwise

Comb Generator

COMB FREQUENCY.....	100MC
INTERPOLATION AMPLITUDE.....	OFF

ADJUSTMENTS

5-17. SECOND CONVERTER LO AND BANDPASS ADJUSTMENTS (Cont'd)

2. Connect equipment as shown in Figure 5-1 and switch display mainframe power ON. Connect counter to A5J3 at the top of A5 Converter Assembly. Connect comb generator to HP 8558B INPUT.
3. Adjust second LO FREQUENCY adjustment A5Z4 for 1748.60 ± 0.2 MHz. Use Allen wrench through center of drilled-out 5/16-inch nut driver to enable nut to be tightened without shifting frequency.
4. Set comb generator for 100 MHz comb.
5. Center a 100 MHz comb tooth using 8558B TUNING control. Turn FREQ SPAN/DIV control to 2 MHz and uncoupled RESOLUTION BW control to 300 kHz, keeping comb tooth centered on display.
6. Loosen lock nut on A5Z1 and A5Z2. Carefully turn tuning screws clockwise until they bottom on cavity.
7. Turn A5Z1 and A5Z2 one turn counterclockwise and lightly tighten lock nuts.
8. Loosen lock nut on A5Z3, and adjust A5Z3 for peak signal on display. Make final adjustment with Amplitude Scale switch in LIN position. It might be necessary to increase gain to see signal in linear mode. Leave in LIN position.
9. Adjust A5Z1 for peak signal on display. Reduce REFERENCE LEVEL as necessary to keep signal on display. Repeat A5Z1 and A5Z3 adjustments for maximum signal on display.
10. Adjust A5Z2 for maximum signal on display. Reduce REFERENCE LEVEL as necessary to keep signal on display.
11. Carefully tighten lock nuts on A5Z1, A5Z2, and A5Z3 so that signal does not change on display.
12. Adjust A5L2 2nd MIXER MATCH adjustment for maximum signal.
13. Check second LO frequency. If frequency error is greater than ± 0.5 MHz, repeat step 3.

ADJUSTMENTS

5-18. THIRD CONVERTER LO AND CAL OUTPUT ADJUSTMENT

REFERENCE

A9 Schematic

DESCRIPTION

The third converter LO frequency is adjusted for maximum output, and power is adjusted for $-30 \text{ dBm} \pm 1.0 \text{ dB CAL OUTPUT}$. The third LO frequency is checked for $280 \text{ MHz} \pm 300 \text{ kHz}$.

002: $+20 \text{ dBmV} \pm 1.0 \text{ dB}$

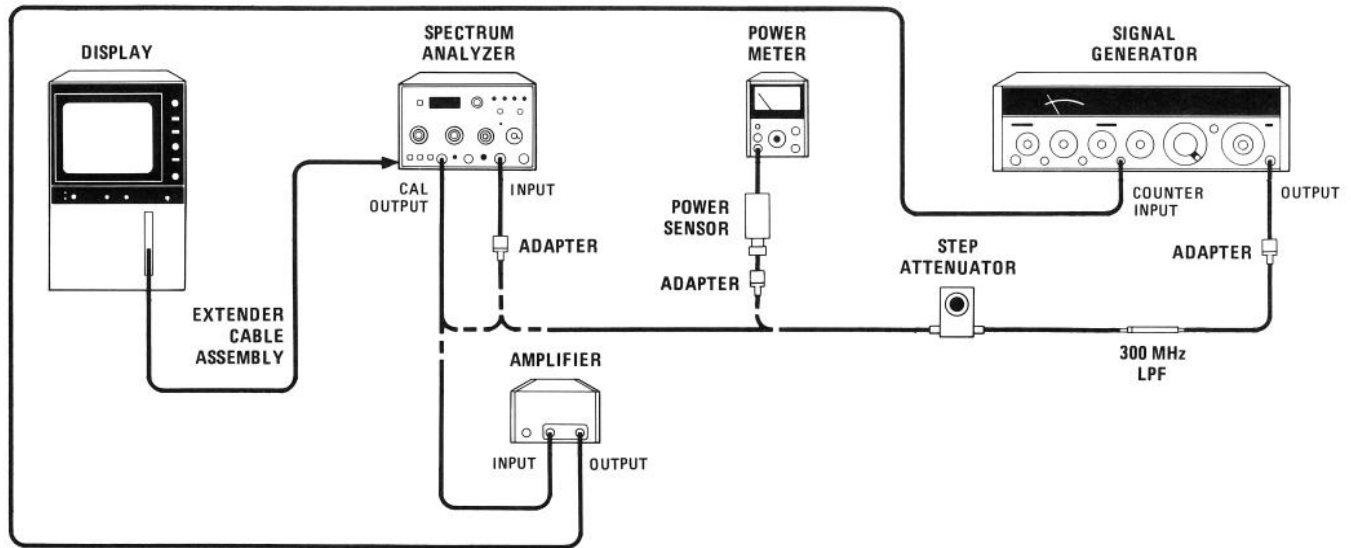

FIGURE 5-3. THIRD CONVERTER LO AND CAL OUTPUT ADJUSTMENT TEST SETUP

EQUIPMENT

Amplifier	HP 8447A
Power Meter	HP 435B
Power Sensor	HP 8482A
Signal Generator	HP 8640B
10 dB Step Attenuator (calibrated at 280 MHz)	HP 355D, Opt. H82
300 MHz LPF	Telonic TLP 300-4AB
Adapter, Type N (m) to BNC (f) (2 required)	HP 1250-0780
Adapter, Type N (f) to BNC (m)	HP 1250-0077
Extender Cable Assembly	HP 5060-0303

Additional Equipment, Options 001 and 002:

<i>Minimum Loss Adapter, 75Ω to 50Ω</i>	<i>HP 08558-60031</i>
<i>Adapter, Type N (m) to SMA (f)</i>	<i>HP 1250-1250</i>

ADJUSTMENTS

5-18. THIRD CONVERTER LO AND CAL OUTPUT ADJUSTMENT (Cont'd)

PROCEDURE

1. Set equipment as follows:

START - CENTER.....	CENTER
TUNING.....	280 MHz
FREQ SPAN/DIV.....	500 kHz
RESOLUTION BW.....	1 MHz
INPUT ATTEN.....	10 dB
REFERENCE LEVEL dBm.....	-20
<i>002: +30 dBmV</i>	
Amplitude Scale.....	LIN
SWEEP TIME/DIV.....	AUTO
Extender Cable Assembly.....	HP 5060-0303

Signal Generator:

OUTPUT LEVEL.....	+10 dBm
FREQUENCY.....	280 MHz
AM.....	OFF
FM.....	OFF
RF.....	ON
COUNTER MODE.....	INT

2. Connect equipment as shown in Figure 5-3. Connect CAL OUTPUT to INPUT 50Ω connector.

001 and 002: 75Ω

3. Center the 280 MHz signal on the display.
4. Adjust A9L4 third converter LO FREQ adjustment for maximum signal amplitude.
5. Tune signal generator to frequency of third converter LO (280 MHz ± 300 kHz).
6. Connect signal generator through 300 MHz LPF to calibrated step attenuator. Set step attenuator to 10 dB.
7. Connect power sensor and power meter to step attenuator as shown in Figure 5-3.
8. Set signal generator OUTPUT LEVEL for a 0 dBm full scale reading on power meter. Leave signal generator set at this level.

001: +5.7 dBm
002: +7.0 dBm

9. Set step attenuator to 40 dB and connect the reference signal set in step 8 (from signal generator through step attenuator) to the 8558B INPUT 50Ω connector.

001 and 002: INPUT 75Ω connector using Minimum Loss Adapter, 75Ω BNC Cable, and Type N (m) to SMA (f) Adapter

ADJUSTMENTS

5-18. THIRD CONVERTER LO AND CAL OUTPUT ADJUSTMENT (Cont'd)

10. Set signal from signal generator to a convenient reference level on display with REFERENCE LEVEL and REF LEVEL FINE controls.
11. Disconnect minimum loss adapter and connect spectrum analyzer CAL OUTPUT to the INPUT 50 Ω connector.

001 and 002: 75 Ω

12. Adjust A9R5 3RD LO PWR adjustment, accessible from bottom of analyzer through motherboard, to the reference set in step 10. (If range is insufficient on A9R5, change value of factory-selected resistor A9R4*.)
13. Connect CAL OUTPUT to amplifier input and connect amplifier output to COUNTER INPUT of 8640B. Set HP 8640B COUNTER MODE to EXT EXPAND X10. The third LO frequency should read 280 MHz \pm 300 kHz.

ADJUSTMENTS

5-19. SLOPE ADJUSTMENT

REFERENCE

A9 Schematic

DESCRIPTION

An externally leveled signal is applied to the INPUT of the spectrum analyzer. The signal is adjusted across the frequency range of the spectrum analyzer. A9R1 SLOPE COMP is adjusted for best flatness, compensating for first converter conversion loss over frequency.

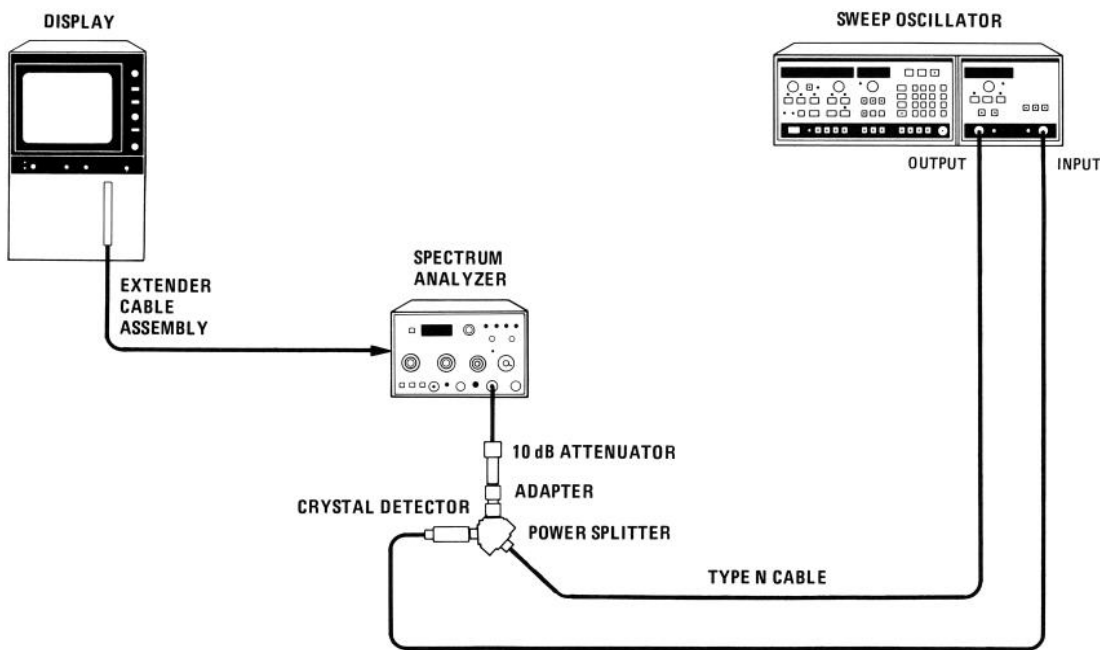

CONFIGURATION FOR OPTION 001, 002

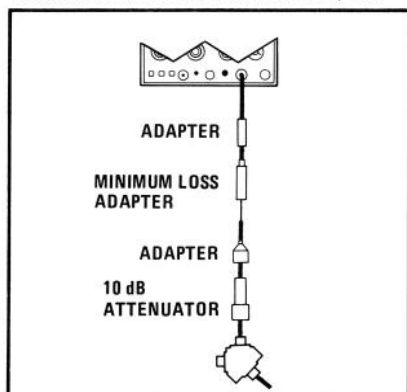

FIGURE 5-4. SLOPE ADJUSTMENT TEST SETUP

ADJUSTMENTS

5-19. SLOPE ADJUSTMENT (Cont'd)

EQUIPMENT

Sweep Oscillator*	HP 8350A
RF Plug-In*	HP 83522A
Power Splitter	HP 11667A
Crystal Detector	HP 423B
10-dB Attenuator	HP 8491B Opt. 010
Adapter, Type N (m) to Type N (m)	HP 1250-1475
BNC Cable, 120 cm (48 in)	HP 10503A
Type N Cable	HP 11500A
Extender Cable Assembly	HP 5060-0303

*8620C/86222A may be substituted

Additional Equipment, Options 001 and 002:

<i>Minimum Loss Adapter, 75Ω to 50Ω</i>	<i>HP 08558-60031</i>
<i>BNC Cable, 30 cm (12 in), 75Ω</i>	<i>HP 11652-60012</i>
<i>Adapter, Type N (m) to SMA (f)</i>	<i>HP 1250-1250</i>

PROCEDURE

1. Set equipment as follows:

Spectrum Analyzer

START – CENTER	CENTER
TUNING	500 MHz
FREQ SPAN/DIV	100 MHz
RESOLUTION BW	1 MHz
INPUT ATTEN	10 dB
REFERENCE LEVEL	-10 dBm
002: +40 dBmV	
REF LEVEL FINE	0
Amplitude Scale	1 dB/DIV
SWEEP TIME/DIV	AUTO
BASELINE CLIPPER	OFF
VIDEO FILTER	OFF

Sweep Oscillator

START	10 MHz
STOP	1.5 GHz
SWEEP	MAN
POWER LEVEL	0 dBm
ALC MODE	EXT
FREQUENCY/TIME	500 MHz

2. Connect equipment as shown in Figure 5-4.

ADJUSTMENTS

5-19. SLOPE ADJUSTMENT (Cont'd)

3. Adjust spectrum analyzer REF LEVEL FINE to bring signal peak on display.
4. Set spectrum analyzer START – CENTER to CENTER. Manually tune sweep oscillator for output frequencies from 10 MHz to 1.0 GHz. Set spectrum analyzer START – CENTER to START. Manually tune sweep oscillator for output frequencies from 1.0 GHz to 1.5 GHz.
5. Using procedure of step 4, locate highest displayed amplitude. Adjust spectrum analyzer REF LEVEL FINE to bring highest displayed amplitude to fifth CRT graticule line from bottom.
6. Using procedure of step 4, locate lowest displayed amplitude.
7. Adjust spectrum analyzer A9R1 SLOPE COMP for minimum difference between highest and lowest displayed amplitudes.
8. Repeat steps 5, 6, and 7 until no further adjustment is necessary.
9. With highest displayed amplitude set to fifth graticule line from bottom lowest displayed amplitude should be at or above third graticule line from bottom.

ADJUSTMENTS

5-20. SECOND IF BANDPASS AMPLIFIER AND BANDPASS FILTER ADJUSTMENT

REFERENCE

A10 Schematic

DESCRIPTION

Tune bandpass amplifier output and bandpass filter.

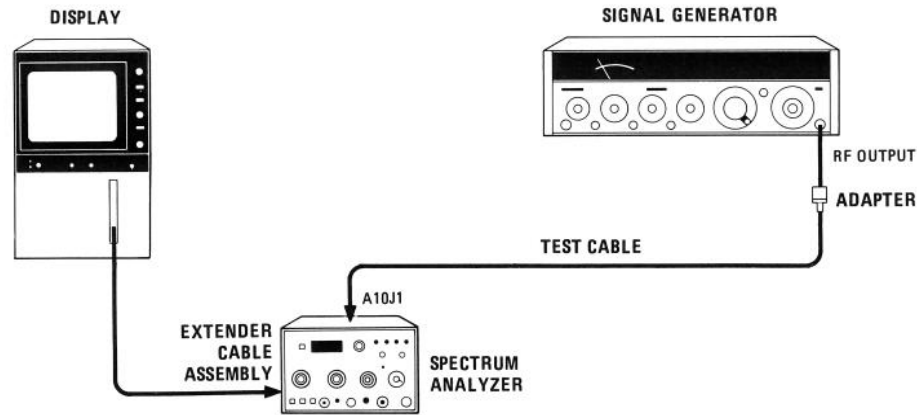

FIGURE 5-5. SECOND IF BANDPASS AMPLIFIER AND BANDPASS FILTER ADJUSTMENT TEST SETUP

EQUIPMENT

Signal Generator	HP 8640B
Adapter, Type N (m) to BNC (f)	HP 1250-0780
Test Cable, SMC (f) to BNC (m)	HP 11592 – 60001
Extender Cable Assembly	HP 5060-0303

PROCEDURE

1. Set spectrum analyzer controls as follows:

FREQ SPAN/DIV	100 MHz
RESOLUTION	1 MHz
INPUT ATTEN	0 dB
REFERENCE LEVEL	-10 dBm
002: +40 dBmV	
Amplitude Scale	10 dB/DIV
SWEEP TIME/DIV	AUTO
SWEEP TRIGGER	FREE RUN

2. Set signal generator frequency to 301.4 MHz and set output level to approximately -35 dBm.

ADJUSTMENTS

5-20. SECOND IF BANDPASS AMPLIFIER AND BANDPASS FILTER ADJUSTMENT (Cont'd)**NOTE**

If 8640B is not used, adjust the signal generator for maximum signal on the display in step 3.

3. Remove W6P2 from Second IF A10J1. Connect signal generator through test cable to A10J1 as shown in Figure 5-5.
4. Adjust bandpass filter capacitors A10C1, A10C2, and A10C3 on Second IF Assembly fully counterclockwise. Adjust REFERENCE LEVEL if necessary for an on-screen display.
5. Adjust A10C1 for maximum signal amplitude. Make final adjustment with Amplitude Scale switch in LIN position. Leave switch in LIN position. Use REFERENCE LEVEL and REF LEVEL FINE controls to keep signal on top half of display.
6. Adjust A10C3 for maximum signal amplitude. There may be a double peak; tune past first peak to second peak. Signal on display will peak and fall off slightly and then peak again.
7. Repeat steps 5 and 6 adjusting A10C1 and A10C3 for maximum amplitude.
8. Adjust A10C2 for maximum signal amplitude. There may be a double peak; tune to second peak. Reduce input signal level to keep signal on display.

NOTE

The following adjustment of A10L2 has very little effect on the signal or performance of the spectrum analyzer. A10L2 need not be adjusted because the position of the core is not critical.

9. Adjust A10L2 2ND IF TUNING adjustment for maximum signal amplitude. L2 is adjusted through motherboard on bottom of analyzer. Reconnect W6P2 to A10J1.

ADJUSTMENTS

5-21. CRYSTAL AND LC BANDWIDTH FILTER ADJUSTMENTS

REFERENCE

A8, A11, and A13 Schematics

DESCRIPTION

The crystal and LC bandwidth filter circuits are adjusted for symmetry, center, and peak. Three-dB bandwidths are adjusted on the Sweep Generator Assembly A8 (paragraph 5-22).

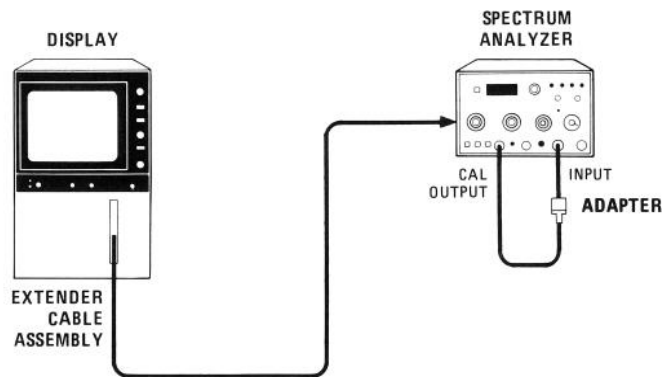

FIGURE 5-6. CRYSTAL AND LC BANDWIDTH FILTER ADJUSTMENT TEST SETUP

EQUIPMENT

Adapter, Type N (m) to BNC (f)	HP 1250-0780
BNC Cable, 20 cm (9 in)	HP 10502A
Crystal Short (3 Required)	See Figure 5-7
Extender Cable Assembly	HP 5060-0303

Additional Equipment, Options 001 and 002:

<i>BNC Cable, 30 cm (12 in), 75Ω</i>	<i>HP 11652-60012</i>
--	-----------------------

NOTE

A crystal short consists of a .01 μF capacitor (HP Part Number 0160-0161) and a 90.9 ohm resistor (HP Part Number 0757-0400) connected in series. Two square-terminal connectors (HP Part Number 0362-0265) are used to connect the crystal short across the test points.

ADJUSTMENTS

5-21. CRYSTAL AND LC BANDWIDTH FILTER ADJUSTMENTS (Cont'd)

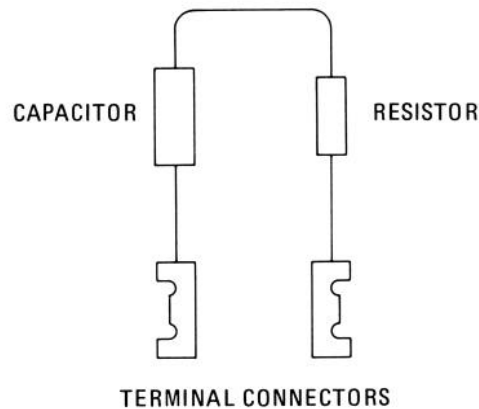

FIGURE 5-7. CRYSTAL SHORT CONFIGURATION

PROCEDURE

NOTE

Allow 30 minutes warmup time before performing adjustments.

1. Set spectrum analyzer controls as follows:

START-CENTER	CENTER
TUNING	280 MHz
FREQ SPAN/DIV	200 kHz
RESOLUTION BW	1 MHz
INPUT ATTEN	0 dB
REFERENCE LEVEL	-20 dBm
002: +30dBmV	
Amplitude Scale	LIN
SWEEP TIME/DIV	10 mSEC
SWEEP TRIGGER	FREE RUN

Crystal Alignment

2. Connect equipment as shown in Figure 5-6.

NOTE

If A8 Sweep Generator has been replaced or adjusted, perform steps 3 through 8. If not, proceed to step 9.

3. Center the signal with TUNING control. Using REF LEVEL FINE control, place signal at 7.1 divisions (0.9 division from top graticule line).
4. Adjust A8R85 LC until signal is 5 divisions wide at the fifth graticule line (1 MHz wide at 3-dB points).

ADJUSTMENTS

5-21. CRYSTAL AND LC BANDWIDTH FILTER ADJUSTMENTS (Cont'd)

5. Set FREQ SPAN/DIV to 5 kHz and RESOLUTION BW to 10 kHz.
6. Center the signal with FINE TUNING control.
7. Using REF LEVEL FINE control, place signal at 7.1 divisions.
8. Adjust A8R72 XTL until signal is 2 divisions wide at the fifth graticule line (10 kHz wide at 3-dB points).
9. Set FREQ SPAN/DIV to 20 kHz and RESOLUTION BW to 30 kHz.
10. Center signal with TUNING control.
11. Adjust REF LEVEL FINE control to place signal at sixth graticule line.

NOTE

A non-metallic tuning tool is required for adjustments on the A11 and A13 bandwidth filter assemblies.

12. Connect crystal shorts (through cover access holes) across the following pairs of test points: A13TP1/TP2, A11TP1/TP2, and A11TP4/TP5.

NOTE

Keep crystal spike centered during adjustments. The SYM and CTR adjustments for each crystal interact.

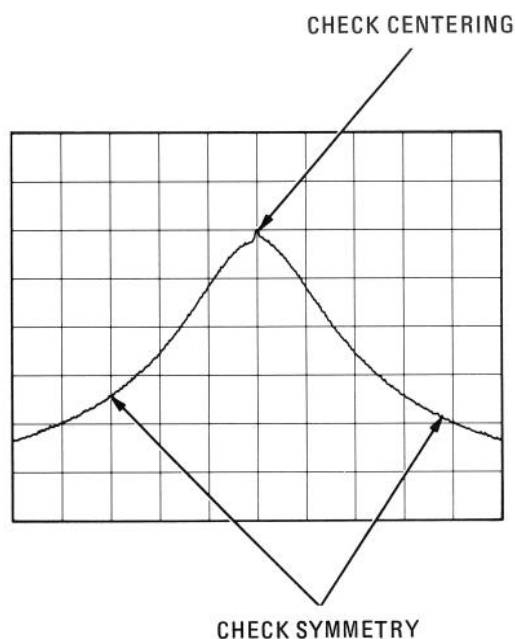

FIGURE 5-8. ADJUSTING CRYSTAL SYMMETRY AND CRYSTAL CENTERING

ADJUSTMENTS

5-21. CRYSTAL AND LC BANDWIDTH FILTER ADJUSTMENTS (Cont'd)

13. Adjust front-panel TUNING control to center bandpass spike (Figure 5-8) on the CRT display.
14. Adjust A13C54 CTR for minimum signal amplitude. Then adjust A13C38 SYM and A13C54 CTR for a centered and symmetrical bandpass as shown in Figure 5-8.
15. Remove crystal short from A13TP1/TP2 and connect it across A13TP4/TP5.
16. Adjust A13C25 CTR for minimum signal amplitude. Then adjust A13C15 SYM and A13C25 CTR for a centered and symmetrical bandpass.
17. Remove crystal short from A11TP4/TP5 and connect it across A13TP1/TP2.
18. Adjust A11C54 CTR for minimum signal amplitude. Then adjust A11C38 SYM and A11C54 CTR for a centered and symmetrical bandpass.
19. Remove crystal short from A11TP1/TP2 and connect it across A11TP4/TP5.
20. Adjust A11C25 CTR for minimum signal amplitude. Then adjust A11C15 SYM and A11C25 CTR for a centered and symmetrical bandpass.
21. Remove the crystal shorts.
22. Set FREQ SPAN/DIV to 5 kHz and RESOLUTION BW to 30 kHz. Center signal on CRT with TUNING control.
23. Switch RESOLUTION BW from 30 kHz to 10 kHz and back, several times. Verify that signal shift does not exceed 3 kHz (0.6 divisions). If signal shift is out of tolerance, return to step 11.

LC Alignment

24. Set RESOLUTION BW control to 100 kHz. Jumper A8TP6 to A8TP8. (This forces the BW7 line to +15V.) Set FREQ SPAN/DIV to 100 kHz.

NOTE

When A11 and A13 Bandwidth Filter Assemblies are installed with covers in place, midget copper alligator clips (HP Part Number 1400-0483) can be used to short test points to the cover.

25. Perform preliminary LC filter adjustments as follows:

NOTE

It might be necessary to adjust the REF LEVEL FINE control to obtain an on-screen display during the following adjustments.

- a. Remove A13 cover and install A13 on extender board.
- b. Short to ground the following test points: A13TP6, A11TP3, and A11TP6. (This widens all but one LC pole.)

ADJUSTMENTS

5-21. CRYSTAL AND LC BANDWIDTH FILTER ADJUSTMENTS (Cont'd)

- c. Center signal on CRT with TUNING control. Adjust A13C73 for minimum signal amplitude.
 - d. Disconnect short from A13TP6 and short to ground A13TP3.
 - e. Adjust A13C74 for minimum signal amplitude.
 - f. Reinstall A13 and cover. Disconnect short from A11TP3. Remove A11 cover and install A11 on extender board.
 - g. Short A13TP6 to ground.
 - h. Adjust A11C73 for minimum signal amplitude.
 - i. Disconnect short from A11TP6 and short to ground A11TP3.
 - j. Adjust A11C74 for minimum signal amplitude.
 - k. Disconnect shorts from test points and reinstall A11 and cover.
26. Short to ground A11TP3, A11TP6, and A13TP3. Set RESOLUTION BW to 100 kHz and set FREQ SPAN/DIV to 20 kHz.
27. Center signal on CRT with TUNING control. Adjust A13C45 LC CTR for symmetrical bandpass display on CRT. Use FINE TUNING control to keep crystal spike centered.
28. Move short from A13TP3 to A13TP6. Leave other shorts in place. Center signal on CRT with TUNING control. Adjust A13C23 LC CTR for symmetrical bandpass display on CRT, keeping crystal spike centered.
29. Move short from A11TP6 to A11TP3. Leave other shorts in place. Center signal on CRT with TUNING control. Adjust A11C45 LC CTR for symmetrical bandpass display on CRT, keeping crystal spike centered.
30. Move short from A11TP3 to A11TP6. Leave other shorts in place. Center signal on CRT with TUNING control. Adjust A11C23 LC CTR for symmetrical bandpass display on CRT, keeping crystal spike centered.
31. Disconnect shorts from A11TP6, A13TP3, A13TP6, and from ground. Remove jumper from A8TP6 and A8TP8.
32. Set FREQ SPAN/DIV to 10 kHz and RESOLUTION BW to 30 kHz. Center signal on CRT with TUNING control. Set RESOLUTION BW to 100 kHz and note where signal crosses center vertical graticule line.
33. Adjust A11C23, A11C45, A13C23, and A13C45 in succession so that amplitude of signal is peaked where it crosses center vertical CRT graticule line, repeating step 32 between adjustments as necessary.
34. Repeat steps 32 and 33 until 30 kHz and 100 kHz bandwidths are centered with each other. If signal shift between 30 kHz and 100 kHz bandwidths is greater than 10 kHz (1 division), repeat steps 24 through 33.
-

ADJUSTMENTS

5-21. CRYSTAL AND LC BANDWIDTH FILTER ADJUSTMENTS (Cont'd)**Bandwidth Amplitude**

35. Set Amplitude Scale switch to 1 dB/DIV and jumper A8TP6 to A8TP8.
36. Short A11TP3, A11TP6, A13TP3, and A13TP6 to ground.
37. Set RESOLUTION BW to 100 kHz and FREQ SPAN/DIV to 200 kHz.
38. Adjust FINE TUNING and REF LEVEL FINE for a centered signal at 7 divisions.
39. Remove shorts from A13TP3 and A13TP6 and center signal with FINE TUNING control. Adjust A13R26 LC for a signal amplitude of 7 divisions.
40. Remove shorts from A11TP3 and A11TP6. Adjust A11R26 LC for a signal amplitude of 7 divisions.
41. Repeat steps 36 through 40 until no further adjustment is necessary.
42. Adjust A11R31 XTL and A13R31 XTL fully counter-clockwise.
43. Set RESOLUTION BW to 1 kHz and FREQ SPAN/DIV to 5 kHz. Center signal with FINE TUNING control. Adjust A11R31 XTL and A13R31 XTL equally for a signal amplitude of 7 divisions. Each potentiometer should be adjusted to accomplish half the necessary increase in signal amplitude.
44. Remove jumper from A8TP6 and A8TP8.
45. Set FREQ SPAN/DIV to 500 kHz and RESOLUTION BW to 3 MHz.
46. Center signal with TUNING control. Adjust REF LEVEL FINE for a signal amplitude of 7 divisions.
47. Step down RESOLUTION BW from 3 MHz to 300 kHz. Variation in signal amplitude should be less than ± 0.4 dB.
48. Set FREQ SPAN/DIV to 20 kHz and step down RESOLUTION BW from 100 kHz to 1 kHz. Variation of signal amplitude should be less than ± 0.7 dB from the 7th division reference.
49. Repeat steps 35 through 46 until variation in signal amplitude is within limits.

ADJUSTMENTS

5-22. 3-dB BANDWIDTH ADJUSTMENT

REFERENCE

A8 Schematic

DESCRIPTION

The 3-dB bandwidths for the 3 MHz, 1 MHz and 300 kHz RESOLUTION BW settings are adjusted using the CAL OUTPUT as the signal source. The 3-dB bandwidths for the 10 kHz, 3 kHz, and 1 kHz RESOLUTION BW settings are adjusted by injecting a stable 301.4 MHz signal into the third converter of the spectrum analyzer.

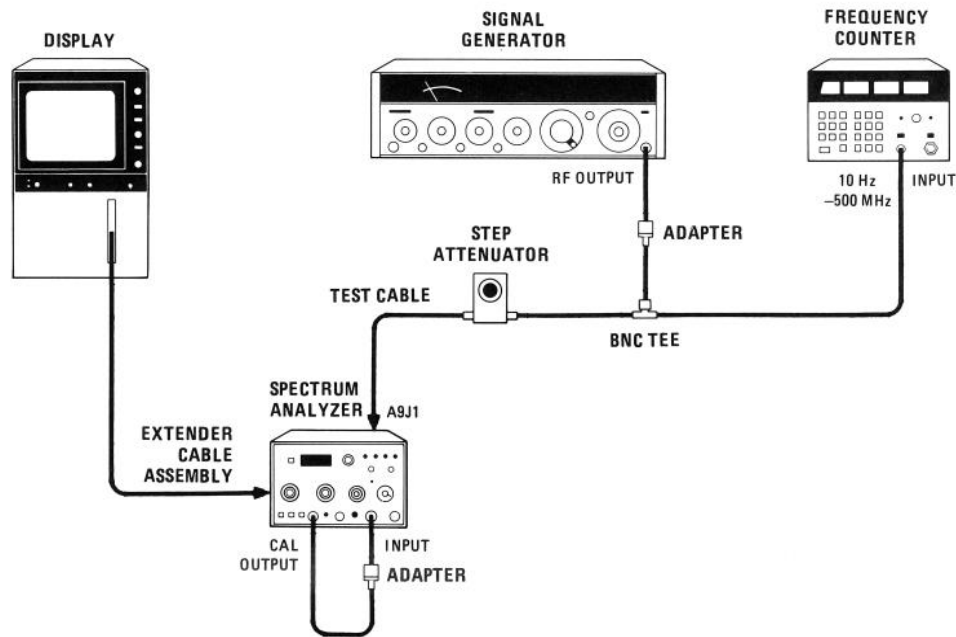

FIGURE 5-9. 3-dB BANDWIDTH ADJUSTMENT TEST SETUP

EQUIPMENT

Signal Generator	HP 8640B
Frequency Counter	HP 5343A
10-dB Step Attenuator	HP 355D
BNC Cable, 20 cm (9 in.)	HP 10502A
Adapter, Type N (m) to BNC (f) (3 required)	HP 1250-0780
BNC Tee	HP 1250-0781
Test Cable, SMC (f) to BNC (m)	HP 11592-60001
Extender Cable Assembly	HP 5060-0303

ADJUSTMENTS

5-22. 3-dB BANDWIDTH ADJUSTMENT (Cont'd)

PROCEDURE

1. Set spectrum analyzer controls as follows:

START - CENTER	CENTER
TUNING	280 MHz
FREQ SPAN/DIV	200 kHz
RESOLUTION BW	1 MHz
INPUT ATTEN	0 dB
REFERENCE LEVEL	-20 dBm
Amplitude Scale	LIN
SWEEP TIME/DIV	1 mSEC
SWEEP TRIGGER	FREE RUN
VIDEO FILTER	OFF

2. Connect equipment as shown in Figure 5-9 except for signal input to A9J1. Connect CAL OUTPUT to spectrum analyzer INPUT 50Ω.
3. Set signal level of 7.1 divisions on display with REF LEVEL FINE control. (Signal should be 0.9 division from top graticule line.)
4. Set RESOLUTION BW to 1 MHz and FREQ SPAN/DIV to 200 kHz. Adjust A8R85 LC to set bandwidth of 5 divisions at the fifth graticule line.
5. Set RESOLUTION BW to 3 MHz and FREQ SPAN/DIV to 500 kHz. The bandwidth at the fifth graticule line should be between 5.4 and 6.6 divisions.

NOTE

A8R85 LC may be further adjusted to bring the 3 MHz and 300 kHz bandwidths within limits; however, the final measurement of the 1 MHz bandwidth must be between 4.5 and 5.5 divisions at the fifth graticule line. (If the 3 MHz bandwidth cannot be brought within limits by adjustment of A8R85 LC, change the value of factory-selected resistor A8R120*.)

6. Set RESOLUTION BW to 300 kHz and FREQ SPAN/DIV to 50 kHz. The bandwidth should be between 5.4 and 6.6 divisions at the fifth graticule line. (If the bandwidth cannot be adjusted within the specified limits, change the value of factory-selected resistor A8R116*.)
7. Set RESOLUTION BW to 100 kHz and FREQ SPAN/DIV to 20 kHz. The bandwidth should be between 4.3 and 5.7 divisions at the fifth graticule line.

NOTE

If the 100 kHz bandwidth is not within the specified limits, change the values of factory-selected resistors A13R19*, A13R43*, A11R19*, and A11R43*. If the bandwidth is too wide, increase the value of the resistors; if the bandwidth is too narrow, decrease the value of the resistors. The four factory-selected resistors need not be of equal value, but each must be within one standard value of the others.

ADJUSTMENTS

5-22. 3-dB BANDWIDTH ADJUSTMENT (Cont'd)

8. Set RESOLUTION BW to 30 kHz and FREQ SPAN/DIV to 5 kHz. The bandwidth should be between 5.2 and 6.8 divisions at the fifth graticule line.

NOTE

If the 30 kHz bandwidth is not within the specified limits, change the values of factory-selected resistors A11R23*, A11R48*, A13R23*, and A13R48*. If the bandwidth is too wide, decrease the value of the factory-selected resistors; if the bandwidth is too narrow, increase the value of the resistors. The four factory-selected resistors need not be of equal value, but each must be within one standard value of the others.

9. Connect signal generator through the BNC Tee connector to the step attenuator and to the frequency counter as shown in Figure 5-9. Set the signal generator to approximately 0 dBm and the step attenuator to 30 dB. Set COUNTER MODE to EXPAND X100.
 10. Remove W7P2 from Third Converter A9J1. Connect step attenuator through test cable to A9J1.
 11. Set HP 8558B RESOLUTION BW to 1 MHz. Tune signal generator to peak signal on CRT display (near 301.4 MHz). Adjust the output level of signal generator to place the signal at 7.1 divisions.
 12. Set RESOLUTION BW to 3 kHz. Tune signal generator to peak signal on CRT display.
 13. Adjust REF LEVEL FINE to place signal at 7.1 divisions.
 14. Note the counter frequency and tune the signal generator 1500 Hz below the center frequency noted. Record the new counter frequency.
 15. Adjust A8R72 XTL to bring signal level to the fifth graticule line (three divisions from the top graticule line).
 16. Increase signal generator frequency until signal on CRT display peaks and then decreases to the fifth graticule line. Record counter frequency.
 17. Compare new frequency with frequency recorded in step 14. The difference between the two frequencies should be 2800 to 3200 Hz. If the bandwidth is not within limits, repeat steps 12 through 17, slightly readjusting A8R72 XTL, until the specified limits are achieved.
 18. Set RESOLUTION BW to 10 kHz. Tune signal generator to peak signal on CRT display.
 19. Adjust REF LEVEL FINE to place signal at 7.1 divisions.
 20. Note the counter frequency and tune the signal generator 5 kHz below the center frequency noted. Record the new counter frequency.
 21. Increase the signal generator frequency until the signal on the CRT display peaks and then decreases to the fifth graticule line. Record counter frequency.
 22. Compare new frequency with frequency recorded in step 20. The difference between the two frequencies should be 9.000 kHz to 11.000 kHz.
-

ADJUSTMENTS

5-22. 3-dB BANDWIDTH ADJUSTMENT (Cont'd)**NOTE**

A8R72 XTL may be further adjusted to bring the 10 kHz and 1 kHz bandwidths within limits; however, the final measurement of the 3 kHz bandwidth must be between 2700 Hz and 3300 Hz. (If the 10 kHz bandwidth cannot be brought within limits by adjustment of A8R72 XTL, change the value of factory-selected resistor A8R111*.)

23. Set RESOLUTION BW to 1 kHz. Tune signal generator to peak signal on CRT display.
24. Adjust REF LEVEL FINE to place signal at 7.1 divisions.
25. Note the counter frequency. Increase signal generator frequency until signal on CRT display peaks and then decreases to the fifth graticule line. Record new counter frequency.
26. Compare new frequency with frequency originally noted in step 25. The difference between the two frequencies should be 450 Hz to 550 Hz.
27. Reconnect W7P2 to A9J1.

ADJUSTMENTS

5-23. STEP GAIN ASSEMBLY RF GAIN ADJUSTMENT

REFERENCE

A12 Schematic

DESCRIPTION

The RF gain (sensitivity) of the Step Gain assembly is adjusted by injecting a 21.4 MHz signal at A16XA9. The Third Converter Assembly A9 is removed and replaced with a special extender board for applying the 21.4 MHz signal from the signal generator.

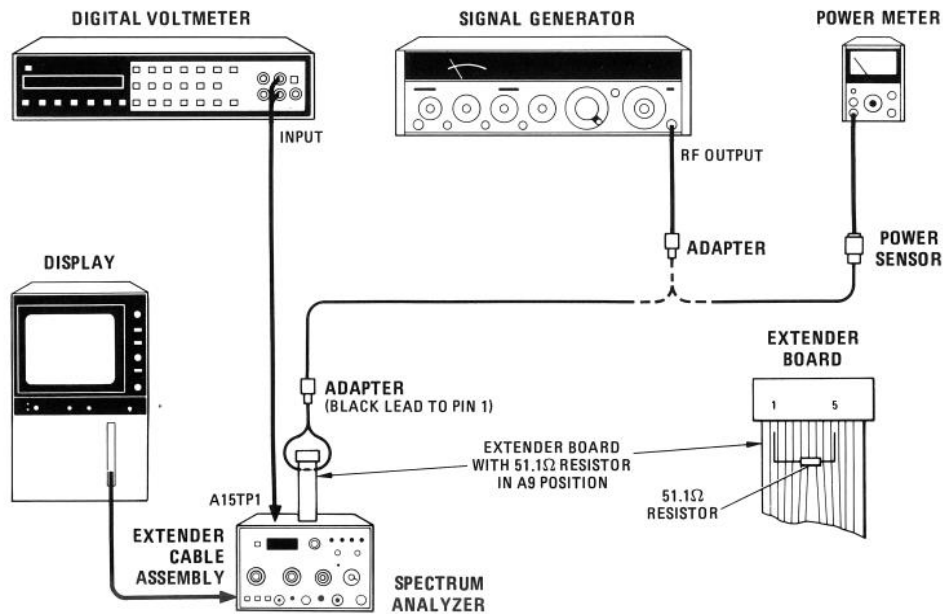

FIGURE 5-10. STEP GAIN ASSEMBLY RF GAIN ADJUSTMENT TEST SETUP

EQUIPMENT

Signal Generator	HP 8640B
Digital Voltmeter	HP 3455A
Power Meter	HP 435B
Power Sensor	HP 8482A
Adapter, BNC (f) to alligator clips	HP 8120-1292
Special Extender Board with 51.1-ohm resistor	HP 08505-60109/0757-0394
BNC Cable, 120 cm (48 in)	HP10503A
Extender Cable Assembly	HP 5060-0303

NOTE

To make special extender board, solder 51.1 ohm resistor from pin 1 to pin 5 of standard extender board, HP Part Number 08505-60109. Leave resistor leads long for easy connection of clip leads.

ADJUSTMENTS

5-23. STEP GAIN ASSEMBLY RF GAIN ADJUSTMENT (Cont'd)

PROCEDURE

1. Set equipment as follows:

Spectrum Analyzer

FREQ SPAN/DIV	1 MHz
RESOLUTION BW	1 MHz
INPUT ATTEN	10 dB
REFERENCE LEVEL	0 dBm
<i>002: +50 dBmV</i>	
REF LEVEL FINE	0
Amplitude Scale	LIN
SWEEP TIME/DIV	AUTO
SWEEP TRIGGER	FREE RUN
VIDEO FILTER	OFF

Digital Voltmeter

RANGE	AUTO
FUNCTION	DC Volts
TRIGGER	INTERNAL
MATH	OFF
AUTO CAL	ON

2. Connect equipment as shown in Figure 5-10.
3. Set signal generator frequency to 21.4 MHz. Set OUTPUT LEVEL for approximately -5 dBm.
4. Connect output of signal generator across 51.1 ohm resistor on special board using BNC to clip-lead adapter. The red lead (center conductor) should be connected to pin 5 of extender board.
5. Set signal generator frequency for peak amplitude on CRT display. Connect output of signal generator to power meter through power sensor and set OUTPUT LEVEL to -1 dBm. Reconnect signal generator output to clip-lead adapter.

001: 6 dBm

002: 7 dBm

6. Adjust A12R4 GAIN adjustment for signal one division from top graticule line. DVM should indicate $+700$ mV ± 30 mV. Remove special extender board and replace Third Converter Assembly A9.

NOTE

Front panel VERTICAL GAIN and VERTICAL POSN control settings can affect the voltage measured at A15TP1. Vertical calibration should be checked after adjusting A12R4 for 700 mV. (Refer to Operator's Check, Section III).

ADJUSTMENTS

5-24. STEP AMPLIFIER GAIN ADJUSTMENTS

REFERENCE

A12 Schematic

DESCRIPTION

REF LEVEL FINE, 0 dB, and -12 dB adjustments are properly set and step gains of 10 dB, 20 dB, and 40 dB are adjusted.

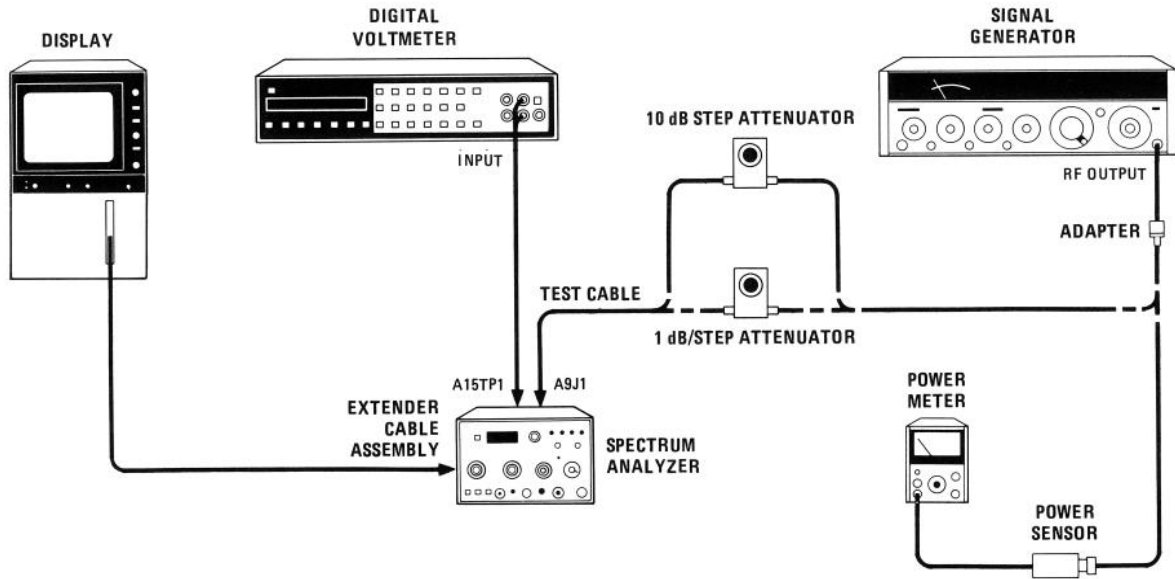

FIGURE 5-11. STEP AMPLIFIER GAIN ADJUSTMENT TEST SETUP

EQUIPMENT

Signal Generator	HP 8640B
1-dB Step Attenuator	HP 355C Opt. H80
10-dB Step Attenuator	HP 355D Opt. H82
Digital Voltmeter	HP 3455A
Power Meter	HP 435B
Power Sensor	HP 8482A
Adapter, Type N (m) to BNC (f)	HP 1250-0780
Test Cable, SMC (f) to BNC (m)	HP 11592-60001
Adapter, SMC (m) to SMC (m)	HP 1250-0827
Extender Cable Assembly	HP 5060-0303

ADJUSTMENTS

5-24. STEP AMPLIFIER GAIN ADJUSTMENTS (Cont'd)

PROCEDURE

1. Set equipment as follows:

TUNING	280 MHz
FREQ SPAN/DIV	1 MHz
RESOLUTION BW	1 MHz
INPUT ATTEN	10 dB
REFERENCE LEVEL.....	0 dBm
002: +50 dBmV	
Amplitude Scale.....	1 dB/DIV
SWEEP TIME/DIV	AUTO
SWEEP TRIGGER.....	FREE RUN
VIDEO FILTER.....	OFF

2. Connect equipment as shown in Figure 5-11. Connect signal generator tuned to 301.4 MHz with approximately -13 dBm output to one side of a 1 dB/step attenuator. Connect attenuator output to A9J1 through test cable. Tune signal generator frequency for peak amplitude on display.
3. Set step attenuator to 12 dB and REF LEVEL FINE to -12 . Set signal generator level for a signal one division down from top graticule line.
4. Adjust A12R6 -12 dB until signal stops rising on display, then adjust A12R6 counterclockwise until signal drops approximately one third to one half of a division.
5. Set signal generator level so signal is one division down from top graticule line on display.
6. Set step attenuator to 0 dB and REF LEVEL FINE to 0.
7. Adjust A12R5 0 dB adjustment for a signal level one division from top graticule line.
8. Set step attenuator to 12 dB and REF LEVEL FINE to -12 . Signal level on display should be ± 0.1 division from the reference one division down from top graticule line. If signal level is out of limits, repeat steps 3 through 8 until the signal level is within limits.
9. Check REF LEVEL FINE control from 0 to -12 dBm, as shown in Table 5-6. Verify correct operation on display, or measure voltage at A15TP1 with digital voltmeter.

NOTE

Be sure all covers in the IF section are secured by at least six screws before proceeding. If covers are left off or not secured by at least six screws, leakage between assemblies may occur. This leakage causes erroneous adjustment.

10. Replace 1 dB/step attenuator with 10 dB/step attenuator set to 0 dB. Set REF LEVEL FINE control to 0.

ADJUSTMENTS

5-24. STEP AMPLIFIER GAIN ADJUSTMENTS (Cont'd)

TABLE 5-6. REF LEVEL FINE CONTROL CHECK

REF LEVEL FINE Setting	Step Attenuator Setting (dB)	Deviation From Reference
0	0	Ref. _____ mV (Ref.)
-1	1	± 0.3 Div ± 30 mV
-2	2	± 0.3 Div ± 30 mV
-3	3	± 0.3 Div ± 30 mV
-4	4	± 0.3 Div ± 30 mV
-5	5	± 0.3 Div ± 30 mV
-6	6	± 0.3 Div ± 30 mV
-7	7	± 0.3 Div ± 30 mV
-8	8	± 0.3 Div ± 30 mV
-9	9	± 0.3 Div ± 30 mV
-10	10	± 0.3 Div ± 30 mV
-11	11	± 0.3 Div ± 30 mV
-12	12	± 0.3 Div ± 30 mV

11. Connect 10 dB step attenuator to A9J1, using test cable.
12. Tune signal generator frequency for peak amplitude on the display (near 301.4 MHz). Adjust HP 8640B output level for a signal one division from the top graticule.
13. Set step attenuator to 10 dB and REFERENCE LEVEL to -10 dBm.
002: +40 dBmV
14. Adjust A12R3 10 dB adjustment for signal level one division from top graticule line.
15. Set step attenuator to 20 dB and REFERENCE LEVEL to -20 dBm.
002: +30dBmV
16. Adjust A12R2 20 dB adjustment for signal level one division from top graticule line.
17. Set attenuator to 40 dB and REFERENCE LEVEL to -40 dBm.
002: +10 dBmV

NOTE

Some video filtering might help reduce noise. Set VIDEO FILTER control so noise is reduced, but the signal amplitude remains unchanged.

18. Adjust A12R1 40 dB adjustment for signal level one division from top graticule line.

ADJUSTMENTS

5-24. STEP AMPLIFIER GAIN ADJUSTMENTS (Cont'd)

19. Check REFERENCE LEVEL control from 0 to -50 dBm as shown in Table 5-7.

002: +50 dBmV to 0 dBmV. REFERENCE LEVEL dBmV settings in Table 5-7 are, from top to bottom, +50, +40, +30, +20, +10, 0.

20. Reconnect W7P2 to A9J1.

TABLE 5-7. REFERENCE LEVEL CONTROL CHECK

REFERENCE LEVEL (dBm)	Step Attenuator Setting (dB)	Deviation From Reference
0	0	Ref. _____ mV (Ref.)
-10	10	±0.2 Div ±20 mV
-20	20	±0.2 Div ±20 mV
-30	30	±0.2 Div ±20 mV
-40	40	±0.2 Div ±20 mV
-50	50	±0.2 Div ±20 mV

ADJUSTMENTS

5-25. + 19.5V ADJUSTMENT

REFERENCE

A12 Schematic

DESCRIPTION

+ 19.5V for YIG Oscillator is adjusted.

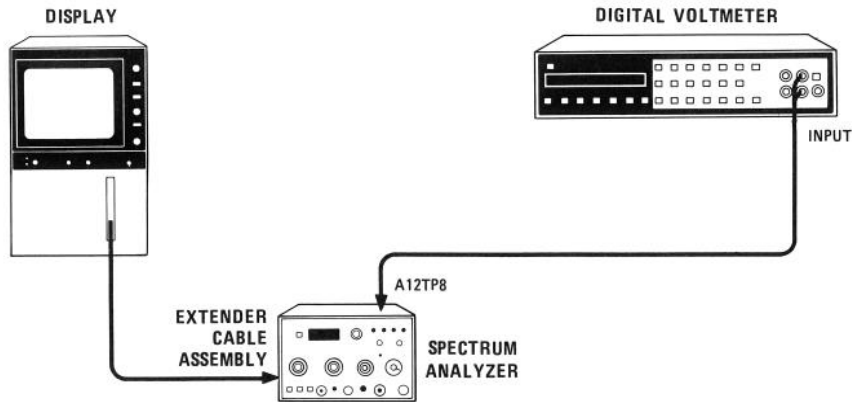

FIGURE 5-12. + 19.5V ADJUSTMENT TEST SETUP

EQUIPMENT

- Digital Voltmeter HP 3455A
- Cable, Banana Plug to Alligator Clip HP 11102A
- Extender Cable Assembly HP 5060-0303

PROCEDURE

1. Set Digital Voltmeter as follows:

- RANGE AUTO
- FUNCTION dcV
- AUTO CAL ON
- TRIGGER INTERNAL

2. Connect equipment as shown in Figure 5-12. Connect digital voltmeter to A12TP8 (left side of A12R7 +19.5V adjustment).
3. Adjust A12R7 +19.5V adjustment for +19.5 ±0.1 V.

ADJUSTMENTS

5-26. LOG AMPLIFIER LOG AND LINEAR ADJUSTMENT

REFERENCE:

A9, A12, A14, and A15 Schematics

DESCRIPTION

Step attenuators are used to change, in calibrated steps, the input signal level of the spectrum analyzer. The output of Vertical Driver and Blanking Assembly A15 is monitored, and adjustments are performed to calibrate Log Amplifier Assembly A14.

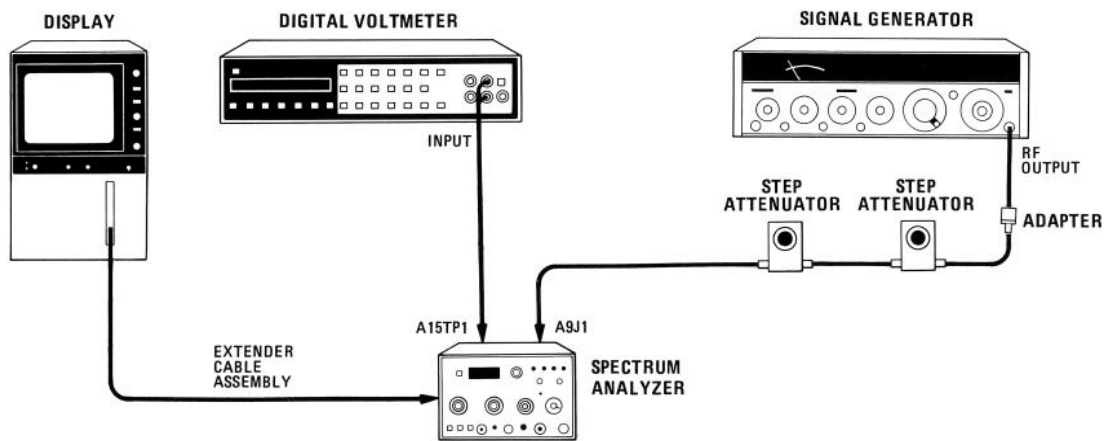

FIGURE 5-13. LOG AMPLIFIER AND LINEAR ADJUSTMENT TEST SETUP

EQUIPMENT:

Signal Generator	HP 8640B
Digital Voltmeter	HP 3455A
10-dB Step Attenuator	HP 355D, Opt. H82
1-dB Step Attenuator	HP 355C, Opt. H80
Adapter, Type N (m) to BNC (f)	HP 1250-0780
BNC Cable, 20 cm (9 in)	HP 10502A
BNC Cable, 120 cm (48 in)	HP 10503A
Cable Assembly, Banana Plug to Alligator Clip	HP 11102A
Test Cable, SMC (f) to BNC (m)	HP 11592-60001
Extender Cable Assembly	HP 5060-0303

ADJUSTMENTS

5-26. LOG AMPLIFIER LOG AND LINEAR ADJUSTMENT (Cont'd)

PROCEDURE

1. Set equipment as follows:

Spectrum Analyzer

FREQ SPAN/DIV 0
 RESOLUTION BW 300 kHz
 INPUT ATTEN 10 dB
 REFERENCE LEVEL -50 dBm
 002: 0 dBmV
 Amplitude Scale LIN
 SWEEP TIME/DIV AUTO
 SWEEP TRIGGER FREE RUN

Digital Voltmeter

RANGE 10
 FUNCTION dcV
 TRIGGER INTERNAL
 MATH OFF
 AUTO CAL ON

2. Connect equipment as shown in Figure 5-13. Set 1-dB step attenuator to 10 dB. Set signal generator frequency to 301.4 MHz and OUTPUT LEVEL to -13 dBm. Remove W7 from A9J1. Connect signal generator output through step attenuators and test cable to A9J1.

NOTE

The HP 355C 10-dB attenuation is included to compensate for the 10 dB of gain on Step Gain Assembly A12 when the TEST-NORM switch is in TEST.

3. Set the TEST-NORM switch on Step Gain Assembly A12 to the TEST position. Tune signal generator frequency for maximum signal amplitude on display with 10 dB step attenuator set to 0 dB. (It may be necessary to reduce signal generator OUTPUT LEVEL slightly.)
4. Disconnect signal generator output from step attenuator. Measure offset at A15TP1 and record.
_____ mV
5. Connect signal generator to step attenuator and adjust signal generator FINE TUNE control to peak signal on CRT display.
6. Adjust signal generator OUTPUT LEVEL for DVM reading (± 1 mV) of 800 mV plus offset recorded in step 4, as measured at A15TP1.
7. Set Amplitude Scale to 10 dB/DIV.
8. Set 10-dB step attenuator to 0 dB and adjust A14R23 SLOPE for DVM reading (± 1 mV) of 800 mV plus offset recorded in step 4, as measured at A15TP1.

ADJUSTMENTS

5-26. LOG AMPLIFIER LOG AND LINEAR ADJUSTMENT (Cont'd)

9. Set 10-dB step attenuator to 60 dB and adjust A14R10 OFFSET for DVM reading (± 1 mV) of 200 mV plus offset recorded in step 4, as measured at A15TP1.
10. Repeat steps 8 and 9 until no further adjustment is necessary.
11. Set 10-dB step attenuator to 30 dB and adjust A14R23 SLOPE for DVM reading (± 1 mV) of 500 mV plus offset recorded in step 4, as measured at A15TP1.
12. Set 10-dB step attenuator to 0 dB and adjust A14R69 – 30 dB for DVM (± 1 mV) of 800 mV plus offset recorded in step 4, as measured at A15TP1.
13. Repeat steps 11 and 12 until no further adjustment is necessary.
14. Set 10-dB step attenuator to 10 dB and adjust A14R23 SLOPE for DVM reading (± 1 mV) of 700 mV plus offset recorded in step 4, as measured at A15TP1.
15. Set 10-dB step attenuator to 0 dB and adjust A14R39 – 10 dB for DVM reading (± 1 mV) of 800 mV plus offset recorded in step 4, as measured at A15TP1.
16. Repeat steps 14 and 15 until no further adjustment is necessary.
17. Repeat steps 8 through 16 until limits in Table 5-8 are met.

TABLE 5-8. LOG FIDELITY CHECK

Step Attenuator Setting (dB)	DVM Reading*
0	Ref: 800 \pm 1 mV
10	700 \pm 3 mV
20	600 \pm 4 mV
30	500 \pm 4 mV
40	400 \pm 5 mV
50	300 \pm 6 mV
60	200 \pm 7 mV
70	100 \pm 8 mV
*Plus offset	

Linear Output and Linear Step Gain

18. Set spectrum analyzer controls as follows:

REFERENCE LEVEL – 50 dBm
 002: 0 dBmV
 Amplitude Scale LIN

ADJUSTMENTS

5-26. LOG AMPLIFIER LOG AND LINEAR ADJUSTMENT (Cont'd)

19. Set 10-dB step attenuator to 0 dB and adjust A14R34 LIN for DVM reading (± 1 mV) of 800 mV plus offset recorded in step 4, as measured at A15TP1.
20. Make adjustments indicated in Table 5-9.

002: REFERENCE LEVEL (dBmV) settings in Table 5-9 are, from top to bottom, 0, -10, -20, -30, -40.

TABLE 5-9. LINEAR GAIN ADJUSTMENTS

Adjustment	Step Attenuator	Reference Level	DVM Reading*
A14R34	0	-50 dBm	Ref: 800 \pm 1 mV
A14R33	10	-60 dBm	800 \pm 5 mV
A14R30	20	-70 dBm	800 \pm 5 mV
A14R27	30	-80 dBm	800 \pm 5 mV
No Adjustment	40	-90 dBm	800 \pm 10 mV
*Plus offset			

Log Gain

21. Set spectrum analyzer control as follows:

REFERENCE LEVEL -50 dBm
 002: 0 dBmV
 Amplitude Scale 1 dB/DIV

22. Set 10-dB step attenuator to 0 dB. Adjust signal generator for DVM reading (± 1 mV) of 800 mV plus offset recorded in step 4, as measured at A15TP1.
23. Set 10-dB step attenuator to 40 dB. Set REF LEVEL to -90 dBm and adjust A14R121 LOG GAIN for DVM reading (± 3 mV) of 800 mV plus offset recorded in step 4, as measured at A15TP1.

002: -40 dBmV

24. Check log gain steps according to Table 5-10.

002: REFERENCE LEVEL (dBmV) settings in Table 5-10 are, from top to bottom, 0, -10, -20, -30, -40.

ADJUSTMENTS

5-26. LOG AMPLIFIER LOG AND LINEAR ADJUSTMENT (Cont'd)

TABLE 5-10. LOG GAIN ADJUSTMENT LIMITS

Step Attenuator	Reference Level	DVM Reading*
0	-50 dBm	Ref: 800 ±1 mV
10	-60 dBm	800 ±30 mV
20	-70 dBm	800 ±30 mV
30	-80 dBm	800 ±30 mV
40	-90 dBm	800 ±30 mV
*Plus offset		

Error Check (1 dB/DIV)

25. Set spectrum analyzer controls as follows:

REFERENCE LEVEL - 50 dBm
 002: 0 dBmV
 Amplitude Scale 1 dB

26. Set both step attenuators to 0 dB. Reduce signal generator OUTPUT LEVEL until signal appears at top of display. Adjust signal generator FINE TUNE to peak trace on display and adjust OUTPUT LEVEL for DVM reading (± 1 mV) of 800 mV plus offset recorded in step 4, as measured at A15TP1. Increase attenuation in 1-dB steps and take DVM readings to check log amplifier output. (Refer to Table 5-11.)

27. Return A12S1 TEST-NORM switch to NORM. Remove test cable and reconnect W7 to A9J1.

TABLE 5-11. LOG AMPLIFIER OUTPUT LIMITS

Step Attenuator	DVM Reading*
1	700 ±10 mV
2	600 ±20 mV
3	500 ±30 mV
4	400 ±30 mV
5	300 ±30 mV
6	200 ±30 mV
7	100 ±30 mV
*Plus offset	

ADJUSTMENTS

5-27. SWEEP TIME PER DIVISION ADJUSTMENT

REFERENCE

A8 Schematic

DESCRIPTION

Sweep time per division is adjusted for proper sweep time and 'dead time.'

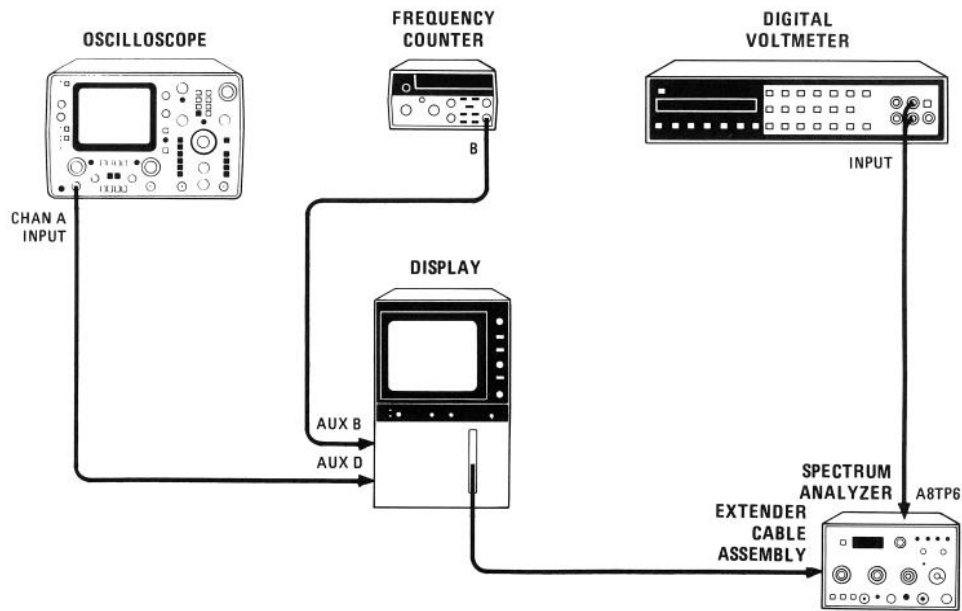

FIGURE 5-14. SWEEP TIME PER DIVISION ADJUSTMENT TEST SETUP

EQUIPMENT

Oscilloscope	HP 1741A
Digital Voltmeter	HP 3455A
Timer/Counter	HP 5308A
BNC Cable, 120 cm (48 in)	HP 10503A
Cable, Banana Plug to Alligator Clips 150 cm (60 in)	HP 11002A
Extender Cable Assembly	HP 5060-0303

ADJUSTMENTS

5-27. SWEEP TIME PER DIVISION ADJUSTMENT (Cont'd)

PROCEDURE

1. Set equipment as follows:

Oscilloscope

DISPLAY	A
TRIGGER	A
CHAN A	2 VOLTS/DIV
AC-GND-DC	DC
WRITE	ON
TIME/DIV	2 mSEC
MAG X5	OFF
EXT TRIGGER	INT
MODE	MAIN

Digital Voltmeter

RANGE	AUTO
FUNCTION	dcV
AUTO CAL	ON
TRIGGER	INTERNAL
MATH	OFF

TIMER/COUNTER

TIME BASE	10 μ S
FUNCTION	PER B

2. Connect equipment as shown in Figure 5-14. Connect oscilloscope to AUX D, HORIZONTAL OUTPUT, rear of display mainframe, or to A8TP5 of HP 8558B. Connect digital voltmeter to A8TP6 (located to the left and below A8TP4.)
3. Adjust A8R2 +10V adjustment for $10V \pm 0.02V$.

NOTE

The +10V must be adjusted while analyzer is still cold, during first five minutes after turn-on. If instrument has been operating, turn off mainframe and remove A8 Sweep Generator assembly. Let A8 assembly cool on bench for 15 minutes. Replace A8 and proceed with adjustment of A8R7 during the first five minutes after turn on.

4. Set spectrum analyzer controls as follows:

SWEEP TIME/DIV	1 ms
SWEEP TRIGGER	FREE RUN

5. Check oscilloscope trace for approximately a $-5V$ to $+5V$ ramp.

ADJUSTMENTS

5-27. SWEEP TIME PER DIVISION ADJUSTMENT (Cont'd)

6. Adjust A8R10 1 ms adjustment for a 10 ms ramp time. Measure dead time of ramp.

MIN.	ACTUAL	MAX.
0.25 ms	_____	0.40 ms

7. Set spectrum analyzer SWEEP TIME/DIV to 5 mSEC. Adjust A8R13 5 ms adjustment for a 20 ms ramp time. Measure dead time of ramp.

MIN.	ACTUAL	MAX.
6.0 ms	_____	9.0 ms

8. Set SWEEP TIME/DIV to 1 mSEC. Frequency counter should read sweep time plus dead time (10 ms + dead time ± 0.8 ms). Adjust A8R10 if necessary to obtain an indication of 10 ms + dead time ± 0.8 ms.

9. Set SWEEP TIME/DIV to 5 mSEC. Frequency counter should read sweep time plus dead time (20 ms + dead time ± 4.0 ms). Adjust A8R13 if necessary to obtain an indication of 20 ms + dead time ± 4.0 ms.

10. Repeat steps 8 and 9 until the sweep time plus dead time (dt) for the 1 ms and 5 ms sweeps are within limits.

MIN.	ACTUAL	MAX.
10 ms + dt - 0.8 ms	_____	10 ms + dt + 0.8 ms
20 ms + dt - 4.0 ms	_____	20 ms + dt + 4.0 ms

11. Check each SWEEP TIME/DIV listed in Table 5-12. If test limits cannot be met, readjust A8R10 (1 ms) and A8R13 (5 ms). The periods in Table 5-12 are without dead times. Subtract dead times from the measured sweep times.

TABLE 5-12. CALIBRATED SWEEP TIME TEST LIMITS

SWEEP TIME/DIV	Period (ms)
.1 ms	1.00 \pm 0.10
.2 ms	2.00 \pm 0.20
.5 ms	5.00 \pm 0.40
1 ms	10.00 \pm 0.80
2 ms	20.00 \pm 1.50
5 ms	50.00 \pm 4.00
10 ms	100.00 \pm 8.00
20 ms	200.00 \pm 16.00
50 ms	500.00 \pm 40.00

ADJUSTMENTS

5-28. FREQUENCY CONTROL AND DPM ADJUSTMENTS

REFERENCE

A1 and A7 Schematics

DESCRIPTION

The +14.5V and REF V voltages are adjusted and the -10.0V voltage is checked. The frequency limits and linearity of the YIG oscillator are set. The FREQUENCY MHz readout is adjusted for proper voltage calibration and for correct ranging.

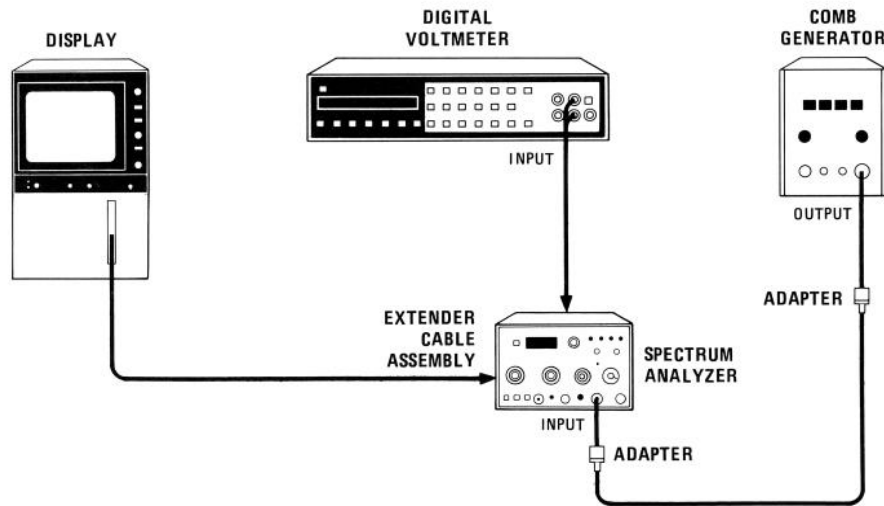

FIGURE 5-15. FREQUENCY CONTROL AND DPM ADJUSTMENTS TEST SETUP

EQUIPMENT

Digital Voltmeter	HP 3455A
Comb Generator	HP 8406A
Adapter, Type N (m) to BNC (f) (2 required)	HP 1250-0780
BNC Cable, 120 cm (48 in)	HP 10503A
Cable, Banana Plug to Alligator Clips 150 cm (60 in)	HP 11002A
Extender Cable Assembly	HP 5060-0303

Additional Equipment, Options 001 and 002:

<i>Minimum Loss Adapter, 75Ω to 50Ω</i>	<i>HP 08558-60031</i>
<i>BNC Cable, 30 cm (12 in), 75Ω</i>	<i>HP 11652-60012</i>
<i>Adapter, SMA (f) to SMA (f)</i>	<i>HP 1250-1158</i>
<i>Adapter, BNC (f) to SMA (m)</i>	<i>HP 1250-1200</i>

ADJUSTMENTS

5-28. FREQUENCY CONTROL AND DPM ADJUSTMENTS (Cont'd)

PROCEDURE

Voltage Adjustments

1. Connect equipment as shown in Figure 5-15. Connect digital voltmeter to A7TP7 (located between A7R4 REF V and A7R5 + 14.5V adjustments).
2. Adjust A7R5 + 14.5V potentiometer for $+14.50 \pm 0.02$ V.
3. Connect digital voltmeter to A7TP8 (located to the right of A7R5 + 14.5V adjustment) and check for -10.0 ± 0.2 V.
4. Connect digital voltmeter to A7TP6 and adjust A7R4 REF V potentiometer for $+6.00 \pm 0.01$ V.

YIG Oscillator Adjustment**NOTE**

Check HORIZ GAIN and HORIZ POSN adjustments and perform voltage adjustments before continuing with the following procedure.

5. Set spectrum analyzer controls as follows:

START - CENTER	CENTER
FREQ SPAN/DIV	5 MHz
RESOLUTION BW	100 kHz
INPUT ATTEN	0 dB
REFERENCE LEVEL	-10 dBm
002: +40 dBmV		
Amplitude Scale	10 dB/DIV
SWEEP TIME/DIV	AUTO
SWEEP TRIGGER	FREE RUN

6. Turn FREQUENCY ZERO control fully counterclockwise.
7. Adjust TUNING for FREQUENCY MHz readout of approximately -16.0.

NOTE

Press FREQUENCY CAL button to remove YIG oscillator hysteresis whenever the TUNING control is adjusted.

8. Adjust A7R3 2.0 GHZ to center LO feedthrough (within one division) on CRT.

NOTE

Disconnect comb generator whenever it is necessary to center the LO feedthrough.

ADJUSTMENTS

5-28. FREQUENCY CONTROL AND DPM ADJUSTMENTS (Cont'd)

9. Couple **FREQ SPAN/DIV** and **RESOLUTION BW** controls. Set **FREQ SPAN/DIV** to 100 MHz/DIV. Set comb generator frequency to 100 MHz. Adjust **TUNING** to approximately 500 MHz for full-screen display of comb teeth.
10. Adjust **TUNING**, **A7R1 3.55 GHZ**, and **A7R2 3.55 FINE** to align comb teeth on vertical graticule lines (one tooth per division).
11. Repeat steps 7 and 8. (**A7R1 3.55 GHZ** adjustment has a slight effect on **A7R3 2.0 GHZ** adjustment.)
12. Set **FREQ SPAN/DIV** to 1 MHz and comb generator frequency to 1 MHz.
13. Adjust **TUNING** to approximately 750 MHz. Adjust **A7R6 FM** to align comb teeth on vertical graticule lines (one tooth per division).

Digital Panel Meter Adjustment

14. Set **FREQ SPAN/DIV** to 500 kHz.
15. Center LO feedthrough. Press **FREQUENCY CAL** button and re-center LO feedthrough.
16. Adjust **FREQUENCY ZERO** control for **FREQUENCY MHz** readout of 00.0.
17. Set comb generator frequency to 100 MHz. Adjust **TUNING** to center 1500-MHz tooth (15th tooth from LO feedthrough). Press **FREQUENCY CAL** button and re-center comb tooth. Adjust **A1A2R3 REF** for **FREQUENCY MHz** readout of 1500 ± 1 .
18. Adjust **A7R8 RNG** fully clockwise. Set comb generator frequency to 10 MHz. Adjust **TUNING** to center 190-MHz comb tooth (19th tooth from LO feedthrough). Adjust **A7R7 GAIN** for **FREQUENCY MHz** readout of 190.0.

NOTE

Press FREQUENCY CAL frequently while counting the comb teeth to avoid miscounting.

19. Adjust **TUNING** for **FREQUENCY MHz** readout of 198.5. Slowly adjust **A7R8 RNG** counterclockwise until range switches (no decimal on **FREQUENCY MHz** display).
20. Center LO feedthrough. Press **FREQUENCY CAL** button and re-center LO feedthrough. Set comb generator frequency to 100 MHz. Adjust **TUNING** to center 200-MHz comb tooth (second tooth from LO feedthrough). Press **FREQUENCY CAL** button and re-center comb tooth. Adjust **A7R72 OFS** for **FREQUENCY MHz** readout of 200.
21. Repeat steps 15 through 21 until 190.0 MHz, 200 MHz, and 1500 MHz readouts on **FREQUENCY MHz** display are calibrated.

ADJUSTMENTS

5-29. 1 dB OFFSET ADJUSTMENT

REFERENCE

A15 Schematic

DESCRIPTION

Reference is set in 10 dB/DIV and 1 dB offset is adjusted in 1 dB/DIV for the same full display reference in 10 dB/DIV.

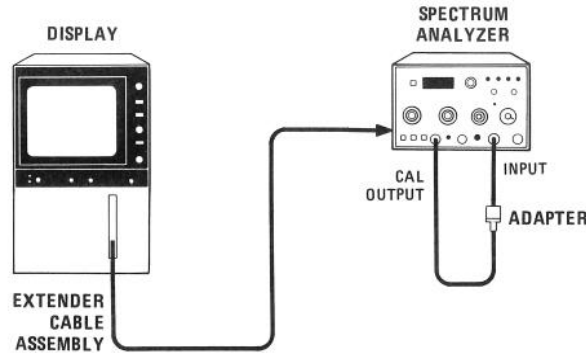

FIGURE 5-16. 1-dB OFFSET ADJUSTMENT TEST SETUP

EQUIPMENT

BNC Cable, 120 cm (9 in)	HP 10502A
Adapter, Type N (m) to BNC (f)	HP 1250-0780
Extender Cable Assembly	HP 5060-0303

Additional Equipment, Options 001 and 002:

BNC Cable, 30 cm (12 in)	HP 11652-60012
------------------------------------	----------------

PROCEDURE

1. Set Spectrum Analyzer controls as follows:

START – CENTER	CENTER
TUNING	280 MHz
FREQ SPAN/DIV	1 MHz
RESOLUTION BW	1 MHz
INPUT ATTEN	10 dB
REFERENCE LEVEL	– 20 dBm
002: +30 dBmV	
REF LEVEL FINE	Approximately – 10
Amplitude Scale	LIN
SWEEP TIME/DIV	AUTO
SWEEP TRIGGER	FREE RUN

ADJUSTMENTS

5-29. 1-dB OFFSET ADJUSTMENT (Cont'd)

2. Connect equipment as shown in Figure 5-16.
3. Set Amplitude Scale switch to LIN. Set TUNING control to center the trace on the display. Set REF LEVEL FINE for a full-screen trace (signal at top graticule line).
4. Set Amplitude Scale switch to 10 dB/DIV. Adjust VERTICAL GAIN if necessary for full screen trace.
5. Repeat steps 3 and 4 until the trace is full screen in both LIN and 10 dB/DIV.

NOTE

1 dB/DIV will read approximately 0.5 dB (0.5 division) low when using extender cable assembly. Adjusting A15R1 1 dB OFFSET for a trace 0.5 division down from top graticule line should place signal at top graticule line when 8558B is properly installed in 180-series mainframe.

6. Amplitude Scale switch to 1 dB/DIV. Adjust A15R1 1 dB OFFSET for a trace 0.5 division down from top graticule line.

SECTION VI REPLACEABLE PARTS

6-1. INTRODUCTION

6-2. The replaceable parts list breakdown for each major assembly is located in Section VIII, following the circuit description for the assembly. This section contains information for ordering the replacement parts not listed in Section VIII. Table 6-1 includes a list of reference designations and a list of abbreviations used in the parts list. Table 6-2 lists names and addresses that correspond to the manufacturer code numbers in the parts list. Table 6-3 lists the replaceable parts in alpha-numerical order by reference designation.

6-3. REPLACEABLE PARTS LIST

6-4. Table 6-3, the list of replaceable parts, is organized as follows:

1. Major assemblies and their part numbers.
2. Accessories supplied and their part numbers.
3. Miscellaneous chassis parts and their part numbers.
4. Mechanical chassis parts and their part numbers.

6-5. The following information is listed for each part:

1. The Hewlett-Packard part number.
2. The part number check digit (CD).
3. The total quantity (Qty) in the instrument. This quantity is given only once, at the first appearance of the part in the list.
4. The description of the part.
5. A five-digit code indicating a typical manufacturer of the part.
6. The manufacturer's part number.

6-6. ORDERING INFORMATION

6-7. To order a part listed in the replaceable parts table, quote the Hewlett-Packard part number (with check digit), indicate the quantity required, and address the order to the nearest Hewlett-Packard office. The check digit will ensure accurate and timely processing of your order.

6-8. To order a part that is not listed in the replaceable parts table, include the instrument model number, instrument serial number, the description and function of the part, and the number of parts required. Address the order to the nearest Hewlett-Packard office.

TABLE 6-1. REFERENCE DESIGNATIONS AND ABBREVIATIONS (1 OF 3)

REFERENCE DESIGNATIONS

A	Assembly	F	Fuse	RT	Thermistor
AT	Attenuator, Isolator, Limiter, Termination	FL	Filter	S	Switch
B	Fan, Motor	HY	Circulator	T	Transformer
BT	Battery	J	Electrical Connector (Stationary Portion), Jack	TB	Terminal Board
C	Capacitor	K	Relay	TC	Thermocouple
CP	Coupler	L	Coil, Inductor	TP	Test Point
CR	Diode, Diode Thyristor, Step Recovery Diode, Varactor	M	Meter	U	Integrated Circuit, Microcircuit
DC	Directional Coupler	MP	Miscellaneous Mechanical Part	V	Electron Tube
DL	Delay Line	P	Electrical Connector (Movable Portion), Plug	VR	Breakdown Diode (Zener), Voltage Regulator
DS	Annunciator, Lamp, Light Emitting Diode (LED), Signaling Device (Visible)	Q	Silicon Controlled Rectifier (SCR), Transistor, Triode Thyristor	W	Cable, Wire, Jumper
E	Miscellaneous Electrical Part	R	Resistor	X	Socket
				Y	Crystal Unit (Piezoelectric, Quartz)
				Z	Tuned Cavity, Tuned Circuit

ABBREVIATIONS

A		CPRSN	Compression	FDTHRU	Feed Through
A	Across Flats, Acrylic, Air (Dry Method), Ampere	CUP-PT	Cup Point	FEM	Female
ADJ	Adjust, Adjustment	CW	Clockwise, Continuous Wave	FIL-HD	Fillister Head
ANSI	American National Standards Institute (formerly USASI-ASA)	D		FL	Flash, Flat, Fluid
ASSY	Assembly	D	Deep, Depletion, Depth, Diameter, Direct Current	FLAT-PT	Flat Point
AWG	American Wire Gage	DA	Darlington	FR	Front
B		DAP-GL	Diallyl Phthalate Glass	FREQ	Frequency
BCD	Binary Coded Decimal	DBL	Double	FT	Current Gain Bandwidth Product (Transition Frequency), Feet, Foot
BD	Board, Bundle	DCCR	Decoder	FXD	Fixed
BE-CU	Beryllium Copper	DEG	Degree	G	
BNC	Type of Connector	D-HOLE	D-Shaped Hole	GEN	General, Generator
BRG	Bearing, Boring	DIA	Diameter	GND	Ground
BRS	Brass	DIP	Dual In-Line Package	GP	General Purpose, Group
BSC	Basic	DIP-SLDR	Dip Solder	H	
BTN	Button	D-MODE	Depletion Mode	H	Henry, High
C		DO	Package Type Designation	HDW	Hardware
C	Capacitance, Capacitor, Center Tapped, Cermet, Cold, Compression	DP	Deep, Depth, Diametric Pitch, Dip	HEX	Hexadecimal, Hexagon, Hexagonal
CCP	Carbon Composition Plastic	DP3T	Double Pole Three Throw	HLCL	Helical
CD	Cadmium, Card, Cord	DPDT	Double Pole Double Throw	HP	Hewlett-Packard Company, High Pass
CER	Ceramic	DWL	Dowel	I	
CHAM	Chamfer	E		IC	Collector Current, Integrated Circuit
CHAR	Character, Characteristic, Charcoal	E-R	E-Ring	ID	Identification, Inside Diameter
CMOS	Complementary Metal Oxide Semiconductor	EXT	Extended, Extension, External, Extinguish	IF	Forward Current, Intermediate Frequency
CNDCT	Conducting, Conductive, Conductivity, Conductor	F		IN	Inch
CONT	Contact, Continuous, Control, Controller	F	Fahrenheit, Farad, Female, Film (Resistor), Fixed, Flange, Frequency	INCL	Including
CONV	Converter	FC	Carbon Film/Composition, Edge of Cutoff Frequency, Face	INT	Integral, Intensity, Internal

TABLE 6-1. REFERENCE DESIGNATIONS AND ABBREVIATIONS (2 OF 3)

<p>J</p> <p>J-FET Junction Field Effect Transistor</p> <p>JFET Junction Field Effect Transistor</p> <p>K</p> <p>K Kelvin, Key, Kilo, Potassium</p> <p>KNRLD Knurled</p> <p>KVDC Kilovolts Direct Current</p> <p>L</p> <p>LED Light Emitting Diode</p> <p>LG Length, Long</p> <p>LIN Linear, Linearity</p> <p>LK Link, Lock</p> <p>LKG Leakage, Locking</p> <p>LUM Luminous</p> <p>M</p> <p>M Male, Maximum, Mega, Mil, Milli, Mode</p> <p>MA Milliampere</p> <p>MACH Machined</p> <p>MAX Maximum</p> <p>MC Molded Carbon Composition</p> <p>MET Metal, Metallized</p> <p>MHZ Megahertz</p> <p>MINTR Miniature</p> <p>MIT Miter</p> <p>MLD Mold, Molded</p> <p>MM Magnetized Material, Millimeter</p> <p>MOM Momentary</p> <p>MTG Mounting</p> <p>MTLC Metallic</p> <p>MW Milliwatt</p> <p>N</p> <p>N Nano, None</p> <p>N-CHAN N-Channel</p> <p>NH Nanohenry</p> <p>NM Nanometer, Nonmetallic</p> <p>NO Normally Open, Number</p> <p>NOM Nominal</p> <p>NPN Negative Positive Negative (Transistor)</p> <p>NS Nanosecond, Non-Shorting, Nose</p> <p>NUM Numeric</p> <p>NYL Nylon (Polyamide)</p> <p>O</p> <p>OA Over-All</p> <p>OD Outside Diameter</p> <p>OP AMP Operational Amplifier</p> <p>OPT Optical, Option, Optional</p>	<p>P</p> <p>PA Picoampere, Power Amplifier</p> <p>PAN-HD Pan Head</p> <p>PAR Parallel, Parity</p> <p>PB Lead (Metal), Pushbutton</p> <p>PC Printed Circuit</p> <p>PCB Printed Circuit Board</p> <p>P-CHAN P-Channel</p> <p>PD Pad, Power Dissipation</p> <p>PF Picofarad, Power Factor</p> <p>PKG Package</p> <p>PLSTC Plastic</p> <p>PNL Panel</p> <p>PNP Positive Negative Positive (Transistor)</p> <p>POLYC Polycarbonate</p> <p>POLYE Polyester</p> <p>POT Potentiometer</p> <p>POZI Pozidriv Recess</p> <p>PREC Precision</p> <p>PRP Purple, Purpose</p> <p>PSTN Piston</p> <p>PT Part, Point, Pulse Time</p> <p>PW Pulse Width</p> <p>Q</p> <p>Q Figure of Merit</p> <p>R</p> <p>R Range, Red, Resistance, Resistor, Right, Ring</p> <p>REF Reference</p> <p>RES Resistance, Resistor</p> <p>RF Radio Frequency</p> <p>RGD Rigid</p> <p>RND Round</p> <p>RR Rear</p> <p>RVT Rivet, Riveted</p> <p>S</p> <p>SAWR Surface Acoustic Wave Resonator</p> <p>SEG Segment</p> <p>SGL Single</p> <p>SI Silicon, Square Inch</p> <p>SL Slide, Slow</p> <p>SLT Slot, Slotted</p> <p>SMA Subminiature, A Type (Threaded Connector)</p> <p>SMB Subminiature, B Type (Slip-On Connector)</p> <p>SMC Subminiature, C Type (Threaded Connector)</p> <p>SPCG Spacing</p> <p>SPDT Single Pole Double Throw</p> <p>SPST Single Pole Single Throw</p> <p>SQ Square</p> <p>SST Stainless Steel</p> <p>STL Steel</p> <p>SUBMIN Subminiature</p> <p>SZ Size</p>	<p>T</p> <p>T Teeth, Temperature, Thickness, Time, Timed, Tooth, Typical</p> <p>TA Ambient Temperature, Tantalum</p> <p>TC Temperature Coefficient</p> <p>THD Thread, Threaded</p> <p>THK Thick</p> <p>TO Package Type Designation</p> <p>TPG Tapping</p> <p>TR-HD Truss Head</p> <p>TRMR Trimmer</p> <p>TRN Turn, Turns</p> <p>TRSN Torsion</p> <p>U</p> <p>UCD Microcandela</p> <p>UF Microfarad</p> <p>UH Microhenry</p> <p>UL Microliter, Underwriters' Laboratories, Inc.</p> <p>UNHDND Unhardened</p> <p>V</p> <p>V Variable, Violet, Volt, Voltage</p> <p>VAC Vacuum, Volts, Alternating Current</p> <p>VAR Variable</p> <p>VDC Volts, Direct Current</p> <p>W</p> <p>W Watt, Wattage, White, Wide, Width</p> <p>W/SW With Switch</p> <p>WW Wire Wound</p> <p>X</p> <p>X By (Used With Dimensions), Reactance</p> <p>Y</p> <p>YIG Yttrium-Iron-Garnet</p> <p>Z</p> <p>ZNR Zener</p>
---	--	---

TABLE 6-1. REFERENCE DESIGNATIONS AND ABBREVIATIONS (3 OF 3)

MULTIPLIERS					
Abbreviation	Prefix	Multiple	Abbreviation	Prefix	Multiple
T	tera	10^{12}	m	milli	10^{-3}
G	giga	10^9	μ	micro	10^{-6}
M	mega	10^6	n	nano	10^{-9}
k	kilo	10^3	p	pico	10^{-12}
da	deka	10	f	femto	10^{-15}
d	deci	10^{-1}	a	atto	10^{-18}
c	centi	10^{-2}			

TABLE 6-2. MANUFACTURERS CODE LIST

Mfr. No.	Manufacturer Name	Address	Zip Code
00000	ANY SATISFACTORY SUPPLIER		
01121	ALLEN-BRADLEY CO	MILWAUKEE, WI	53204
01295	TEXAS INSTR INC SEMICOND CMPNT DIV	DALLAS, TX	75222
02111	SPECTROL ELECTRONICS CORP	CITY OF IND, CA	91745
02660	BUNKER RAMO CORP AMPHENOL CONN DIV	BROADVILLE, IL	60153
02768	ILLINOIS TOOL WORKS INC FASTEX DIV	DES PLAINES, IL	60016
03888	K D I PYROFILM CORP	WHIPPANY, NJ	07981
04713	MOTOROLA SEMICONDUCTOR PRODUCTS	PHOENIX, AZ	85008
11236	CTS OF BERNE INC	BERNE, IN	46711
12969	UNITRODE CORP	WATERTOWN, MA	02172
13606	SPRAGUE ELECT CO SEMICONDUCTOR DIV	CONCORD, NH	03301
18736	VOLTRONICS CORP	HANOVER, NJ	07936
19701	MEPCO/ELECTRA CORP	MINERAL WELLS, TX	76067
24046	TRANSITRON ELECTRONIC CORP	WAKEFIELD, MA	01880
24546	CORNING GLASS WORKS (BRADFORD)	BRADFORD, PA	16701
28480	HEWLETT-PACKARD CO CORPORATE HQ	PALO ALTO, CA	94304
3L585	RCA CORP SOLID STATE DIV	SOMERVILLE, NJ	
30983	MEPCO/ELECTRA CORP	SAN DIEGO, CA	92121
52763	STETTNER ELECTRONICS INC	CHATTANOOGA, TN	13035
56289	SPRAGUE ELECTRIC CO	NORTH ADAMS, MA	01247
71041	BOSTON GEAR WKS DIV OF NA ROCKWELL	QUINCY, MA	02171
72136	ELECTRO MOTIVE CORP	FLORENCE, SC	06226
72982	ERIE TECHNOLOGICAL PRODUCTS INC	ERIE, PA	16512
74970	JOHNSON E F CO	WASECA, MN	56093
78707	TEK BEARING CO INC	NEW YORK, NY	10013
9N171	UNITRODE CORP	LEXINGTON, MA	
92830	ASSOCIATED SPRING CORP	BRISTOL, CT	06010

TABLE 6-3. REPLACEABLE PARTS

Reference Designator	HP Part Number	C D	Qty	Description	Mfr. Code	Mfr. Part Number
MAJOR ASSEMBLIES						
A1				NOT ASSIGNED		
A1A1				NOT ASSIGNED		
A1A2	08558-60125	1	1	DPM DRIVER ASSEMBLY	28480	08558-60125
A2	08558-60100	2	1	FRONT SWITCH ASSEMBLY	28480	08558-60100
A2A1	08558-60160	4	1	SWITCH BOARD ASSEMBLY	28480	08558-60160
A3	5086-7363	9	1	INPUT ATTENUATOR	28480	5086-7363
A4	08558-60004	5	1	FIRST CONVERTER ASSEMBLY	28480	08558-60004
A5	08558-60097	6	1	SECOND CONVERTER ASSEMBLY	28480	08558-60097
A5A1	08558-60028	3	1	SECOND CONVERTER OSCILLATOR ASSEMBLY	28480	08558-60028
A6	5086-7080	7	1	OSCILLATOR, YIG	28480	5086-7080
A7	08558-60126	2	1	FREQUENCY CONTROL ASSEMBLY	28480	08558-60126
A8	08558-60173	9	1	SWEEP GENERATOR ASSEMBLY	28480	08558-60173
A9	08558-60154	6	1	THIRD CONVERTER ASSEMBLY	28480	08558-60154
	8558-60155	7	1	THIRD CONVERTER ASSEMBLY OPT. 001 AND 002	28480	08558-60155
A10	08558-60010	3	1	SECOND IF ASSEMBLY	28480	08558-60010
A11	08559-60058	0	1	BW FILTER NO. 1 ASSEMBLY	28480	08559-60058
A12	08558-60012	5	1	STEP GAIN ASSEMBLY	28480	08558-60012
	08558-60073	8	1	STEP GAIN ASSEMBLY OPT. 001 AND 002	28480	08558-60073
A13	08559-60058	0	1	BW FILTER NO. 2 ASSEMBLY	28480	08559-60058
A14	5061-5411	2	1	LOG AMPLIFIER ASSEMBLY	28480	5061-5411
A15	08558-60115	9	1	VERTICAL DRIVER ASSEMBLY	28480	08558-60115
A16	08558-60175	1	1	MOTHERBOARD ASSEMBLY	28480	08558-60175
A17	08558-60035	2	1	INVERTER ASSEMBLY	28480	08558-60035
ELECTRICAL CHASSIS PARTS						
U1	5086-7282	1	1	LIMITER, RF INPUT, THRESH = 1MW; MAX = 10W, 2WDC	28480	5086-7282
W1	08558-60038	5	1	CABLE ASSY-50 OHM INPUT (STD. SEE FIG. 6-1)	28480	08558-60038
W1	08558-60031	8	1	CABLE ASSY-50 OHM INPUT (OPT. 001 AND 002)	28480	08558-60031
W2				NOT ASSIGNED		
W3	08558-20071	2	1	CABLE ASSY-FIRST LO OUTPUT	28480	08558-20071
W4	08558-20090	5	1	CABLE ASSY-YIG OSC TO FIRST CONVERTER	28480	08558-20090
W5	08558-20073	4	1	CABLE ASSY-FIRST CONVERTER TO SECOND CONVERTER	28480	08558-20073
W6	08558-60047	6	1	CABLE ASSY-SECOND CONVERTER TO SECOND IF	28480	08558-60047
W7	08558-60048	7	1	CABLE ASSY-SECOND IF TO THIRD CONVERTER	28480	08558-60048
W8	08558-60046	5	1	CABLE ASSY-50 OHM CAL OUTPUT (STD)	28480	08558-60046
	08558-60074	9	1	CABLE ASSY-75 OHM CAL OUTPUT (OPT. 001 AND 002)	28480	08558-60074
W9				NOT ASSIGNED		
W10	08557-60045	3	1	CABLE ASSY-VERT. OUTPUT	28480	08557-60045
W11				NOT ASSIGNED		
W12				NOT ASSIGNED		
W13				NOT ASSIGNED		
W14	08558-20117	7	1	CABLE ASSY-ATTEN TO LIMITER	28480	08558-20117
W15	08558-20116	6	1	CABLE ASSY-LIMITERT TO FIRST CONVERTER	28480	08558-20116
W16	08558-60170	6	1	CABLE ASSY-PROBE POWER	28480	08558-60170
MECHANICAL PARTS						
SEE FIGURE 6-2 FOR A COMPLETE LISTING OF MECHANICAL CHASSIS PARTS.						
ACCESSORIES SUPPLIED						
	11593A	7	1	TERMINATION-50 OHM	28480	11593A
	1250-0780	5	1	ADAPTER, TYPE N MALE TO BNC FEMALE	28480	1250-0780
	5020-8565	7	1	CRT OVERLAY, 180-SERIES DISPLAYS	28480	5020-8565
	5020-8566	8	1	CRT OVERLAY, 180-SERIES DISPLAYS	28480	5020-8566
	5020-8567	9	1	CRT OVERLAY, 180-SERIES DISPLAYS	28480	5020-8567
	08558-60131	9	1	SIDE STOP KIT	28480	08558-60131

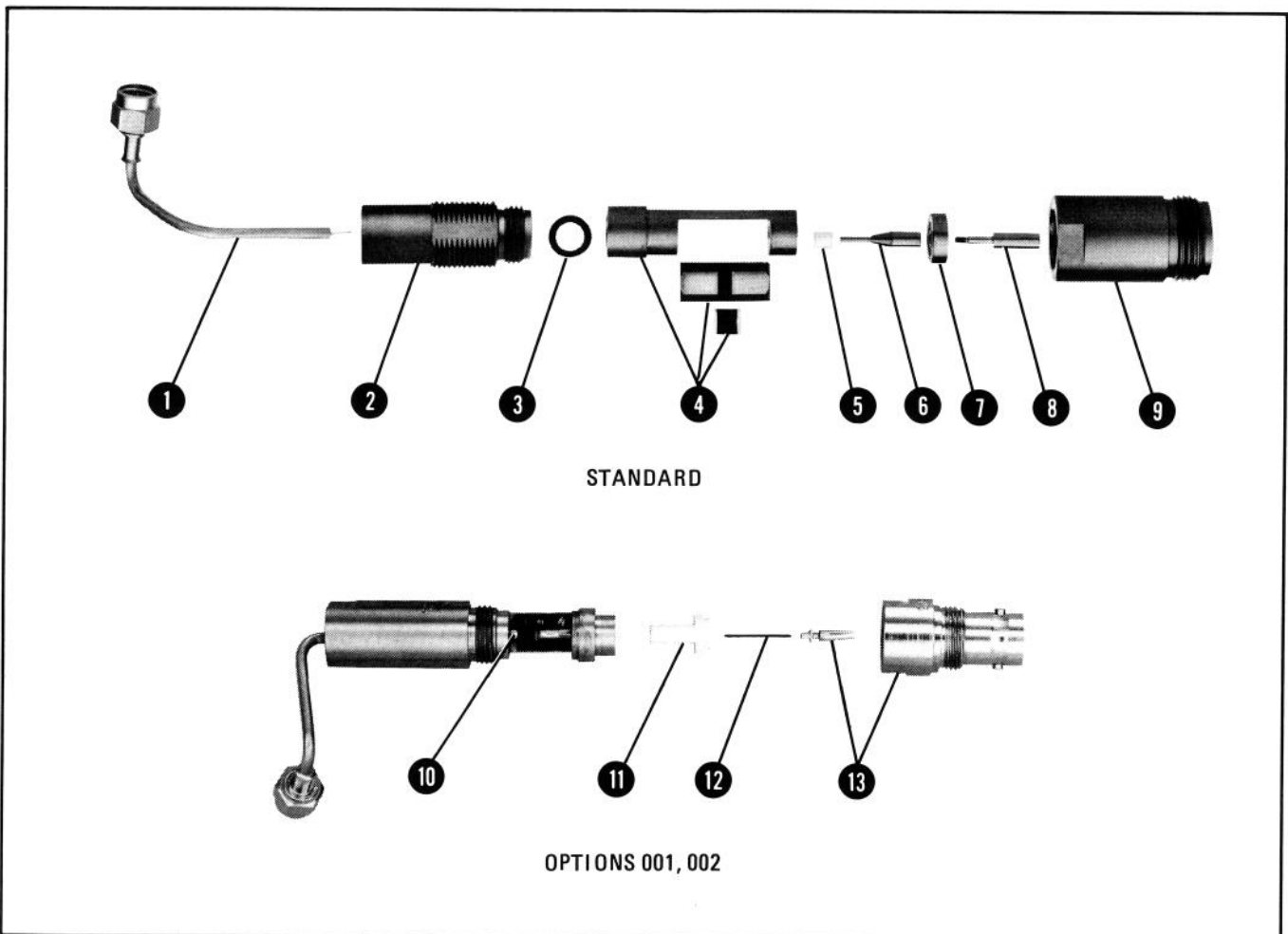

Reference Designation	HP Part Number	C D	Qty	Description	Mfr Code	Mfr Part Number
1	08558-20080	3	1	Assy: Cable (Includes W1P1)	28480	08558-20080
2	08558-20079	0	1	Shell: Type-N Capacitor	28480	08558-20079
3	3050-0253	5	1	Washer: Spring	28480	3050-0253
4	08558-60127	3	1	Blocking Capacitor Assy	28480	08558-60127
5	08558-20077	8	1	Dielectric	28280	08558-20077
6	08558-20076	7	1	Conductor: Inner Type-N	28480	08558-20076
7	5040-0306	0	1	Capacitor Insulator	28480	5040-0306
8	1250-0915	8	1	Contact: RF Connector	02660	131-149
9	1250-0914	7	1	Body: RF Connector	02660	131-150
10	0160-3344	1	1	Capacitor: 0.12 μ F 50 Vdc	28480	0160-3344
11	08558-20101	9	1	Dielectric	28480	08558-20101
12				24 AWG Wire		
13	1250-0505	2	1	RF Connector: 75 ohm (separate white teflon dielectric supplied with connector and pin is not used)	28480	1250-0505

FIGURE 6-1. CABLE ASSEMBLY W1 (08558-60038 OR 08558-60031) REPLACEABLE PARTS

Ref. Desig.	HP Part Number	C D	Qty	Description	Mfr. Code	Mfr. Part Number
				MECHANICAL CHASSIS PARTS NOTE COMPLETE FRONT PANEL ASSEMBLIES (LISTED BELOW) INCLUDE A2 FRONT SWITCH ASSY, PANEL, ALL KNOBS, & PROBE POWER INPUT, CAL OUTPUT, AND LO OUTPUT CABLES		
	08558-60161	5	1	FRONT PANEL ASSY (STD.)	28480	08558-60161
	08558-60164	8		FRONT PANEL ASSY (OPT. 001)	28480	08558-60164
	08558-60165	9	1	FRONT PANEL ASSY (OPT. 002)	28480	08558-60165
1	08558-00114	2	1	PANEL-FRONT (STD.)	28480	08558-00114
1	08558-00121	1	1	PANEL-FRONT (OPT.001)	28480	08558-00121
1	08558-00122	2	1	PANEL-FRONT (OPT.002)	28480	08558-00122
2	08558-00116	4	1	SIDE GUSSET (LEFT)	28480	08558-00116
3	08558-00115	3	1	SIDE GUSSET (RIGHT)	28480	08558-00115
4	08558-00003	8	1	PANEL (REAR)	28480	08558-00003
5	5021-3231	6	1	GUIDE RAIL (TOP)	28480	5021-3231
6	08565-20093	7	4	EXTRUSION, CIRCUIT ENCLOSURE, TAPPED	28480	08565-20093
7	08558-20037	0	1	EXTRUSION, END PLATE ENCLOSURE	28480	08558-20037
8	08558-20036	9	4	EXTRUSION, CIRCUIT ENCLOSURE, TAPPED	28480	08558-20036
9	08565-20051	7	1	EXTRUSION, CIRCUIT ENCLOSURE	28480	08565-20051
10	08558-20038	1	1	EXTRUSION, ENCLOSURE DIVIDER	28480	08558-20038
11	08565-20096	0	8	EXTRUSION, CIRCUIT ENCLOSURE, TAPPED	28480	08565-20096
12	5021-3229	2	1	WINDOW, FREQ. DISPLAY (GLUED TO 1)	28480	5021-3229
13	08558-00030	1	1	INSULATOR-GUIDE RAIL (BOTTOM)	28480	08558-00030
14	5021-3254	3	1	GUIDE RAIL (BOTTOM)	28480	5021-3254
15	08557-60045	3	1	CABLE ASSY (W10) VERTICAL OUTPUT	28480	08557-60045
16	2200-0165	6	2	SCREW-MACH 4-40 .25-IN-LG 82 DEG	28480	2200-0165
17	2360-0194	9	4	SCREW-MACH 6-32 .312-IN-LG 100 DEG	28480	2360-0194
18	2200-0104	3	6	SCREW-MACH 4-40 .25-IN-LG 82 DEG	28480	2200-0104
19	2360-0201	9	2	SCREW-MACH 6-32 .5-IN-LG PAN-HD-POZI	28480	2360-0201
20	0624-0099	1	81	SCREW-TPG 4-40 .375-IN-LG PAN-HD-POZI	28480	0624-0099
21	0624-0206	2	1	SCREW-TPG 6-32 .25-IN-LG PAN-HD-POZI	28480	0624-0206
22	2200-0103	2	12	SCREW-MACH 4-40 .25-IN-LG PAN-HD-POZI	28480	2200-0103
23	2360-0115	4	3	SCREW-MACH 6-32 .312-IN-LG PAN-HD-POZI	28480	2360-0115
24	2200-0170	3	1	SCREW-MACH 4-40 .625-IN-LG 82 DEG	28480	2200-0170
25	0380-0005	1	1	SPACER-RND .312 IN-LG .18-IN-ID	28480	0380-0005
26	2260-0003	7	1	NUT-HEX-PLSTC LKG 4-40-THD .141-IN-THK	28480	2260-0003
27	2200-0105	4	6	SCREW-MACH 4-40 .312-IN-LG PAN-HD-POZI	28480	2200-0105
28	2200-0164	5	2	SCREW-MACH 4-40 .188-IN-LG UNCT 82 DEG	28480	2200-0164
29	2200-0168	9	3	SCREW-MACH 4-40 .438-IN-LG 82 DEG	28480	2200-0168
30	08558-00108	4	1	COVER-LOG AMPLIFIER	28480	08558-00108
31	5001-5828	9	1	COVER-BANDWIDTH FILTER NO. 1	28480	5001-5828
32	08558-00088	9	1	COVER-STEP GAIN	28480	08558-00088
33	5001-5828	9	1	COVER-BANDWIDTH FILTER NO. 2	28480	5001-5828
34	0380-0005	1	1	SPACER-RND .312 IN-LG .18-IN-ID	28480	0380-0005
35	3050-0105	6	4	WASHER-FL MTLG NO. 4 .125-IN-ID	28480	3050-0105
36	1400-0082	9	2	CLAMP-CABLE .125-IDIA .375-WD NYL	28480	1400-0082
37	2420-0001	5	2	NUT-HEX-W/LKWR 6-32-THD .109-IN-THK	28480	2420-0001
38	2190-0016	3	2	WASHER-LK INTL T 3/8 IN .377-IN-ID	28480	2190-0016
39	2950-0043	8	1	NUT-HEX-DBL-CHAM 3/8-32-THD .094-IN-THK	28480	2950-0043
40	2190-0068	5	1	WASHER-LK INTL T 1/2 IN .505-IN-ID	28480	2190-0068
41	2950-0054	1	1	NUT-HEX-DBL-CHAM 1/2-28-THD .125-IN-THK	28480	2950-0054
42	0370-0606	7	4	BEZEL-PB .330-IN-SQ; JADE GRAY	28480	0370-0606
43	5040-8817	4	3	PUSHBUTTON- SQUARE; JADE GRAY	28480	5040-8817
44	08565-40011	1	1	POINTER-INPUT ATTENUATOR	28480	08565-40011
45	1460-0532	0	1	SPRING-CONICAL	28480	1460-0532
46	08558-60166	0	1	KNOB ASSY-REFERENCE LEVEL (OPT. 002)	28480	08558-60166
46	08558-60167	1	1	KNOB ASSY-REFERENCE LEVEL (STD. OPT. 001)	28480	08558-60167
47	08558-00123	3	1	INDEX DISK (OPT. 002) REFERENCE LEVEL	28480	08558-00123
47	08565-00043	5	1	INDEX DISK (STD. OPT. 001) REFERENCE LEVEL	28480	08565-00043
48	0510-0089	8	1	RETAINER-RING BSC EXT .188-IN-DIA BE-CU	28480	0510-0089
49	08565-60047	5	1	KNOB ASSY, REF. LEVEL (FINE)	28480	08565-60047
50	08558-20161	1	1	KNOB ASSY, RESOLUTION BW	28480	08558-20161
51	08558-20162	2	1	KNOB ASSY, FREQ. SPAN/DIV	28480	08558-20162
52	5040-8819	6	1	PUSHBUTTON-SQUARE, WILLOW GREEN	28480	5040-8819
53	0590-1251	6	2	NUT-SPCLY 15/32-32-THD .1-IN-THK .562-WD	28480	0590-1251
54	0370-3060	3	1	KNOB-LOCK	28480	0370-3060
55	08558-60170	6	1	CABLE ASSY-PROBE POWER (W16)	28480	08558-60170
56	08558-60031	8	1	CABLE ASSY-75 OHM INPUT (W1) OPT. 001, 002	28480	08558-60031
56	08558-60038	5	1	CABLE ASSY-50 OHM INPUT (W1) STD. SEE FIG 6-1	28480	08558-60038
57	0370-3021	6	1	KNOB ASSY-MANUAL SWEEP	28480	0370-3021
58	08558-20163	3	1	KNOB ASSY-SWEEP TIME/DIV	28480	08558-20163
59	08559-20050	8	1	KNOB ASSY-SWEEP TRIGGER	28480	08559-20050
60	0370-3006	7	1	KNOB ASSY-FINE TUNE	28480	0370-3006
61	0370-3004	5	1	KNOB ASSY-COARSE TUNE	28480	0370-3004
62	08565-60170	5	2	KNOB-BASELINE CLIP/VIDEO FILTER	28480	08565-60170
63*	2190-0390	6	1	WASHER-FL NM 1/4 IN .26-IN-ID .562-IN-OD	28480	2190-0390
64	2950-0001	8	1	NUT-HEX-DBL-CHAM 3/8-32-THD .094-IN-THK	28480	2950-0001
65	2200-0119	0	2	SCREW-MACH 4-40 1-IN-LG PAN-HD-POZI	28480	2200-0119
66*	3050-0929	2	1	WASHER-FL NM 1/4 IN .26-IN-ID .562-IN-OD (SHIM WASHER, NOT SHOWN, USED WITH 63 FOR PROPER SPACING BETWEEN 46 AND 47.)	28480	3050-0929

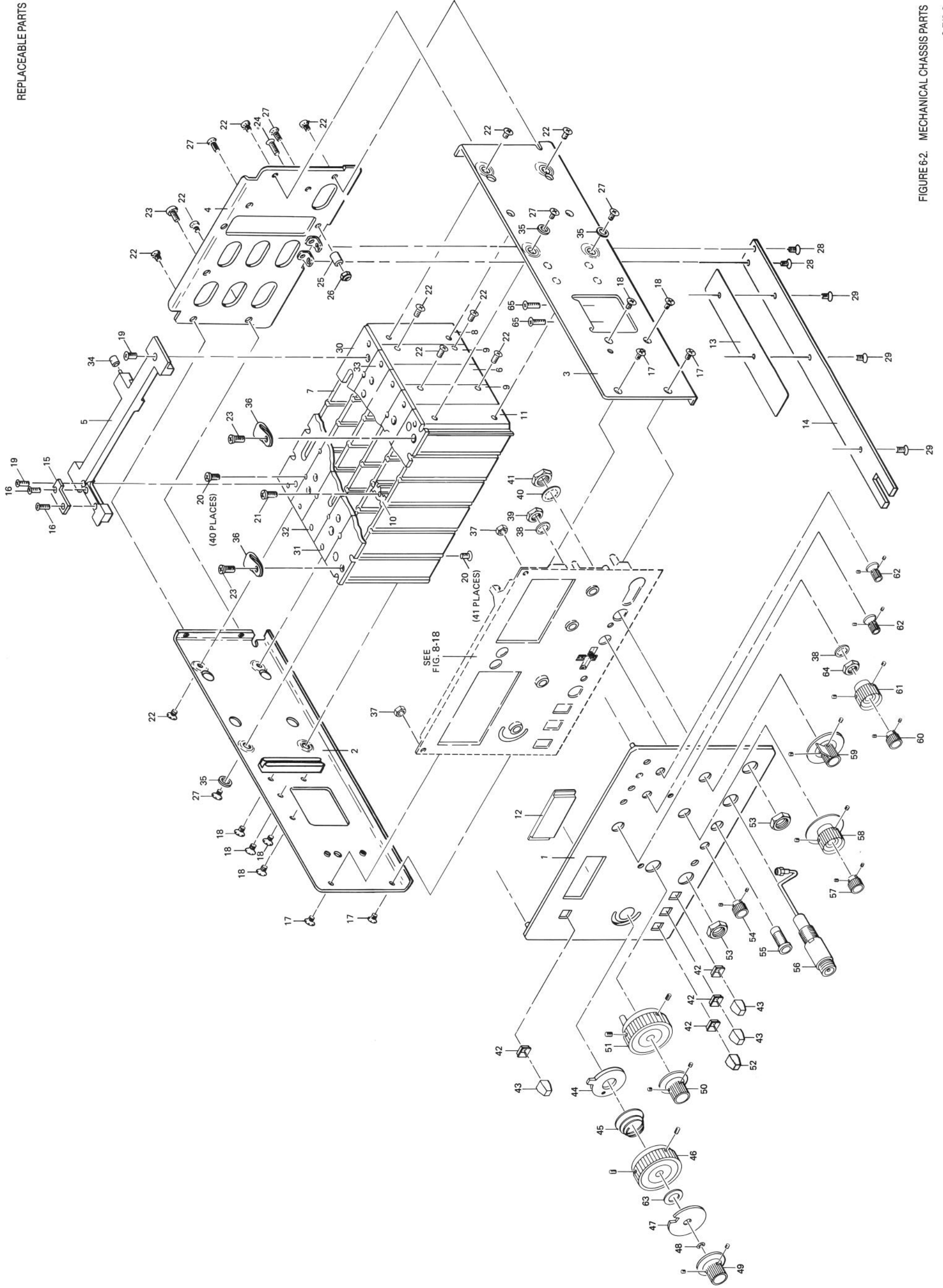

FIGURE 6-2. MECHANICAL CHASSIS PARTS

SECTION VII MANUAL BACKDATING CHANGES

7-1. INTRODUCTION

7-2. This Manual Backdating supplement contains information for adapting this manual to earlier HP 8558B Spectrum Analyzers. If the serial number prefix of your spectrum analyzer appears on the title page of this manual, the contents of the manual are directly applicable to your instrument. If, however, your spectrum analyzer has a lower serial number prefix than what is shown on the title page, you must adapt this manual to your instrument by changing it as indicated in this Manual Backdating supplement.

7-3. If your instrument has a higher serial number prefix than what is shown on the title page of this manual, it will be

documented in a yellow MANUAL UPDATING CHANGES supplement. For additional important information about serial number coverage, refer to INSTRUMENTS COVERED BY MANUAL in Section I.

7-4. HOW TO USE THIS BACKDATING INFORMATION

7-5. Change and correction information in this supplement is organized by manual page number with the serial prefix numbers given in descending order. Make changes as indicated in manual change instructions, inserting any complete replacement pages in the proper location. The original manual pages may be discarded or the original manual may be left intact to document all instrument configurations.

PAGES 1-3 THROUGH 1-6:

Table 1-1. HP Model 8558B Specifications

2118A & Below In Table 1-1, Specifications (1 of 4), under CALIBRATOR OUTPUT, change "+-300 kHz" to "+-50 kHz".

PAGES 1-7 THROUGH 1-9:

Table 1-2. HP Model 8558B/180-Series Supplemental Characteristics

2118A & Below	In Table 1-2, Supplemental Characteristics (3 of 3), under CAL OUTPUT, change text to read as follows: "-30 dBm, 280 MHz with 2nd through 5th harmonics greater than -60 dBm. 002: +20 dBmV, 280 MHz with 2nd through 5th harmonics greater than -10 dBmV."
---------------	---

PAGE 3-2:

2145A & Below

Paragraph 3-17. Amplitude

Change all references to front-panel control "INPUT ATTEN (dB)" to read "OPTIMUM INPUT".

PAGE 3-5/3-6: Figure 3-1. HP 8558B/853A Controls, Connectors, and Indicators

2145A & Below

Both here, and in the operation booklet (8558B Spectrum Analyzer Operation), change the front-panel "PUSH TO LOCK" designation to "LOCK" (rotate clockwise to lock the 8558B into the mainframe). Change "Input Atten (dB)" to "Optimum Input".

Paragraph 37

2145A & Below

Change title from INPUT ATTEN to OPTIMUM INPUT.
Change description to read: "The optimum and maximum input level selected is designated by the pointer behind the control. Push in control knob and turn it to select the required input level range."
Use Table 7-1, included in this Manual Backdating supplement, to translate input attenuation levels given in manual to optimum input levels.

TABLE 7-1. OPTIMUM INPUT TABLE (2145A & BELOW)

INPUT ATTEN (dB)	OPTIMUM INPUT	OPTION 001	OPTION 002
0	-40 dBm	-35 dBm	15 dBmV
10	-30 dBm	-25 dBm	25 dBmV
20	-20 dBm	-15 dBm	35 dBmV
30	-10 dBm	-5 dBm	45 dBmV
40	0 dBm	5 dBm	55 dBmV
50	10 dBm	15 dBm	65 dBmV
60	20 dBm	25 dBm	75 dBmV
70	30 dBm	30 dBm	80 dBmV

PAGES 4-1 THROUGH 4-62: SECTION IV. PERFORMANCE TESTS

2145A & Below

In all Performance Tests, change all references to front-panel control "INPUT ATTEN (dB)" to read "OPTIMUM INPUT". When doing Performance Tests use Table 7-1, included in this Manual Backdating supplement, to translate input attenuation levels given in the manual to optimum input levels.

PAGES 5-1 THROUGH 5-52: SECTION V. ADJUSTMENTS

2145A & Below

In all Adjustments, change all references to front-panel control "INPUT ATTEN (dB)" to read "OPTIMUM INPUT". When doing Adjustments use Table 7-1, included in this Manual Backdating supplement, to translate input attenuation levels given in the manual to optimum input levels.

PAGE 5-3:

2215A & Below

Table 5-2. Adjustable Components

In Table 5-2, Adjustable Components (1 of 4), make the following changes:
For A8R13 Reference Designator, change adjustment name to 2 ms, and the description to "...to calibrate 2 ms per division..."
Change Reference Designator A8R2 to A8R7.

2142A & Below

Add to Table 5-2:

Adjustment LOG GAIN, A14R1, paragraph 7-6, adjusts dc offset circuitry at output of Log Amplifier for 10 dB steps in Log mode.
Adjustment LOG/LIN, A14R2, paragraph 7-6, adjusts for Log-to-Linear full-screen display translations.
Adjustment LIN GAIN, A14R3, paragraph 7-6, adjusts Log Amplifier for 10 dB gain steps in Linear mode. Affects adjustment of LOG/LIN.

PAGE 5-7:

2215 & Below

Table 5-3. Factory Selected Components in Alpha-Numerical Order
Add the Reference Designator A8R125, with Paragraph Number 5-22, "Selected for optimum automatic sweep time with VIDEO FILTER on (but not in detent)."

- Change A8R42 to A8R30.
- Change A8R47 to A8R35.
- Change A8R109 to A8R74.
- Change A8R110 to A8R76.
- Change A8R111 to A8R78.
- Change A8R116 to A8R89.
- Change A8R118 to A8R92.
- Change A8R120 to A8R95.
- Change A8R68 to A8R105.

Change A9R14 to A9R25.

- 1926A prefixes and
- 1914A with suffixes
- 04747, 04918, 04993,
- 05158, 05160, 05172,
- 05228, 05229, 05252,
- 05281, 05297, 05300
- thru 05307, 05311,
- 05312, 05313, 05316,
- 05318, 05320.

PAGES 5-23 THROUGH 5-28:

2147A & Below **Paragraph 5-21. Crystal and LC Bandwidth Filter Adjustments**
Replace Paragraph 5-21 with Paragraph 7-7, CRYSTAL AND LC BANDWIDTH FILTER
ADJUSTMENTS (2147A & BELOW) included in this Manual Backdating
supplement.

ADJUSTMENTS

7-7. CRYSTAL AND LC BANDWIDTH FILTER ADJUSTMENTS (2147A & BELOW)

REFERENCE

A8, A11, and A13 Schematics

DESCRIPTION

The crystal and LC bandwidth filter circuits are adjusted for symmetry, center, and peak. Three-dB bandwidths are adjusted on the Sweep Generator Assembly A8 (paragraph 5-22).

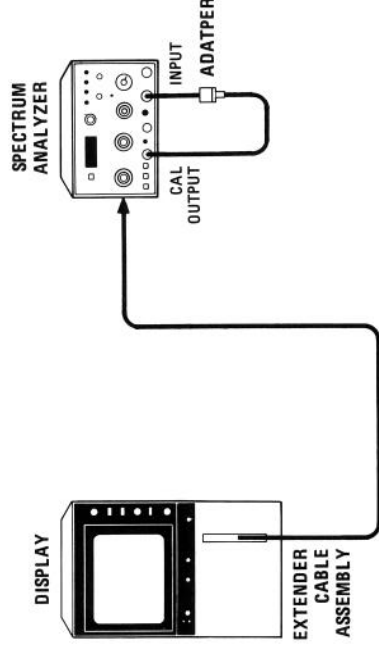

Figure 7-11. Crystal and LC Bandwidth Filter Adjustment Test Setup

EQUIPMENT

- Adapter, Type N (m) to BNC (f)..... HP 1250-0780
- BNC Cable, 20 cm (9 in)..... HP 10502A
- Crystal Short (3 Required)..... See Figure 5-7.
- Extender Cable Assembly HP 5060-0303

Additional Equipment, Options 001 and 002:

- BNC Cable, 30 cm (12 in), 75Ω..... HP 11652-60012

NOTE

A crystal short consists of a .01 μF capacitor (HP Part No. 0160-0161) and a 90.9 ohm resistor (HP Part No. 0757-0400) connected in series. Two square-terminal connectors (HP Part No. 0362-0265) are used to connect the crystal short across the test points.

ADJUSTMENTS

7-7. CRYSTAL AND LC BANDWIDTH FILTER ADJUSTMENTS (2147A & BELOW) (Cont'd)

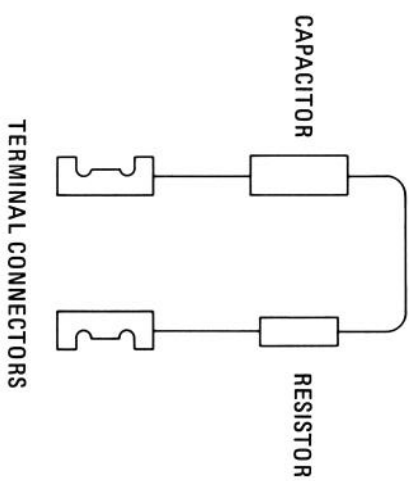

Figure 7-12. Crystal Short Configuration

PROCEDURE

NOTE

Allow 30 minutes warmup time before performing adjustments.

1. Set spectrum analyzer controls as follows:

START - CENTER.....	CENTER
TUNING.....	280 MHz
FREQ SPAN/DIV.....	5 kHz
RESOLUTION BW.....	1 kHz
INPUT ATTEN.....	0 dB
REFERENCE LEVEL.....	-20 dBm
002: +30 dBmV	
Amplitude Scale.....	LIN
SWEEP TIME/DIV.....	10 mSEC
SWEEP TRIGGER.....	FREE RUN

Crystal Alignment

2. Connect equipment as shown in Figure 7-11.

NOTE

If A8 Sweep Generator has been replaced or adjusted, perform steps 3 through 9. If not, proceed to step 10.

3. Set FREQ SPAN/DIV to 500 kHz and RESOLUTION BW to 1 MHz.
4. Center the signal with TUNING control. Using REF LEVEL FINE control, place signal at 7.1 divisions (0.9 division from top graticule line).

ADJUSTMENTS

7-7. CRYSTAL AND LC BANDWIDTH FILTER ADJUSTMENTS (2147A & BELOW) (Cont'd)

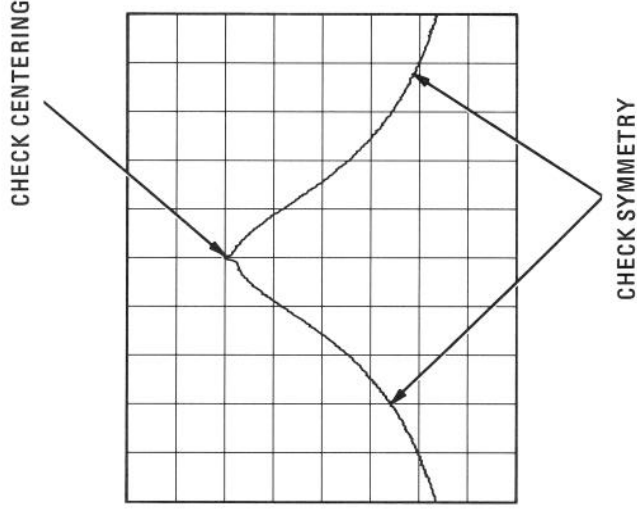

Figure 7-13. Adjusting Crystal Symmetry and Crystal Centering

5. Adjust A8R85 LC until signal is two divisions wide at the fifth graticule line (1 MHz wide at 3-dB points).
6. Set **FREQ SPAN/DIV** to 5 kHz and **RESOLUTION BW** to 10 kHz.
7. Using **REF LEVEL FINE** control, place signal at 7.1 divisions.
8. Adjust A8R72 XTL until signal is two divisions wide at the fifth graticule line (10 kHz wide at 3-dB points).
9. Set **FREQ SPAN/DIV** to 5 kHz and **RESOLUTION BW** to 1 kHz.
10. Center signal with **TUNING** control. (It might be necessary to increase **FREQ SPAN/DIV** temporarily to find the signal.) Set **REF LEVEL FINE** control to place signal at sixth graticule line.
11. Set **FREQ SPAN/DIV** to 20 kHz and **RESOLUTION BW** to 30 kHz.

NOTE

A non-metallic tuning tool is required for adjustments on the A11 and A13 bandwidth filter assemblies.

12. Connect crystal shorts (through cover access holes) across A13TP1/TP2, A11TP1/TP2, and A11TP4/TP5.

ADJUSTMENTS

7-7. CRYSTAL AND LC BANDWIDTH FILTER ADJUSTMENTS (2147A & BELOW) (Cont'd)**NOTE**

Keep crystal spike centered during adjustments. The SYM and CTR adjustments for each crystal interact.

13. Adjust front-panel TUNING control to center bandpass spike (Figure 5-8) on the CRT display.
14. Adjust A13C38 SYM and A13C54 CTR for a centered and symmetrical bandpass as shown in Figure 7-13. Adjust A13C54 CTR for minimum signal amplitude.
15. Remove crystal short from A13TP1/TP2 and connect it across A13TP4/TP5.
16. Adjust A13C15 SYM and A13C25 CTR for a centered and symmetrical bandpass. Adjust A13C25 CTR for minimum signal amplitude.
17. Remove crystal short from A11TP4/TP5 and connect it across A13TP1/TP2.
18. Adjust A11C38 SYM and A11C54 CTR for a centered and symmetrical bandpass. Adjust A11C54 CTR for minimum signal amplitude.
19. Remove crystal short from A11TP1/TP2 and connect it across A11TP4/TP5.
20. Adjust A11C15 SYM and A11C25 CTR for a centered and symmetrical bandpass. Adjust A11C25 CTR for minimum signal amplitude.
21. Remove the crystal shorts.

LC Alignment

22. Perform preliminary LC filter adjustments as follows:
 - a. Install A13 on extender board. Set RESOLUTION BW control to 100 KHz.
 - b. Short to ground the following test points: A13TP6, A11TP3, and A11TP6. Jumper A8TP1 to A8TP2.
 - c. Adjust A13C73 for minimum signal amplitude.
 - d. Disconnect short from A13TP6 and short to ground A13TP3.
 - e. Adjust A13C74 for minimum signal amplitude.
 - f. Reinstall A13 and install A11 on extender board.
 - g. Disconnect short from A11TP3 and short to ground A13TP6.
 - h. Adjust A11C73 for minimum signal amplitude.
 - i. Disconnect short from A11TP6 and short to ground A11TP3.

ADJUSTMENTS

7-7. CRYSTAL AND LC BANDWIDTH FILTER ADJUSTMENTS (2147A & BELOW) (Cont'd)

- j. Adjust A11C74 for minimum signal amplitude.
- k. Disconnect shorts from test points and reinstall A11. Replace covers on A11 and A13 assemblies. Remove jumper from A8TP1/A8TP2.

NOTE

When A11 and A13 BW Filter Assemblies are installed with covers in place, midget copper alligator clips (HP Part No. 1400-0483) can be used to short test points to the cover.

- 23. Carefully center signal on CRT in 30 kHz RESOLUTION BW; then switch RESOLUTION BW to 100 kHz. Note where signal intersects the center vertical graticule line.
- 24. Adjust A13C45 LC CTR for maximum signal amplitude where the signal intersects the center vertical graticule line.
- 25. Switch RESOLUTION BW to 30 kHz and center signal; then switch to 100 kHz. Note where signal intersects the center vertical graticule line.
- 26. Adjust A13C23 LC CTR for maximum signal amplitude where the signal intersects the center vertical graticule line.
- 27. Switch RESOLUTION BW to 30 KHz and center signal; then switch to 100 kHz. Note where signal intersects the center vertical graticule line.
- 28. Adjust A11C45 LC CTR for maximum signal amplitude where the signal intersects the center vertical graticule line.
- 29. Switch RESOLUTION BW to 30 kHz and center signal; then switch to 100 kHz. Note where signal intersects the center vertical graticule line.
- 30. Adjust A11C23 LC CTR for maximum signal amplitude where the signal intersects the center vertical graticule line.
- 31. Switch RESOLUTION BW between 100 kHz and 30 kHz to be sure the signal is centered at both bandwidth settings.
- 32. Set FREQ SPAN/DIV to 5 kHz and RESOLUTION BW to 1 kHz. Center signal with TUNING control.

Bandwidth Amplitude

- 33. Set A11R31 XTL and A13R31 XTL fully counterclockwise.
- 34. Set Amplitude Scale switch to 1 dB/DIV.
- 35. Jumper A8TP1 to A8TP2. Short A11TP3, A11TP6, A13TP3, and A13TP6 to ground.

ADJUSTMENTS

7-7. CRYSTAL AND LC BANDWIDTH FILTER ADJUSTMENTS(2147A & BELOW) (Cont'd)

36. Set RESOLUTION BW to 1 MHz and FREQ SPAN/DIV to 50 KHz.
37. Adjust fine TUNING and REF LEVEL FINE for a centered signal at 7 divisions.
38. Remove shorts from A13TP3 and A13TP6 and center signal with fine TUNING control. Adjust A13R26 LC for a signal amplitude of 7 divisions.
39. Remove shorts from A11TP3 and A11TP6. Adjust A11R26 LC for a signal amplitude of 7 divisions.
40. Repeat steps 35 through 39 until no further adjustment is necessary.
41. Set RESOLUTION BW to 1 KHz and FREQ SPAN/DIV to 5 KHz. Center signal with fine TUNING control. Adjust A11R31 XTL and A13R31 XTL equally for a signal amplitude of 7 divisions.

NOTE

Each potentiometer should be adjusted to accomplish half the necessary increase in signal amplitude.

42. Remove jumper from A8TP1 and A8TP2.
43. Set FREQ SPAN/DIV to 100 MHz and RESOLUTION BW to 3 MHz and push in to couple the two controls.
44. Turn coupled controls to set FREQ SPAN/DIV to 50 MHz and RESOLUTION BW to 1 MHz. Center signal with TUNING control. Adjust REF LEVEL FINE for a signal amplitude of 7 divisions.
45. With controls coupled, step down RESOLUTION BW from 1 MHz to 300 KHz. Variation in signal amplitude should be less than ± 0.4 dB.
46. Step down RESOLUTION BW from 100 KHz to 1 KHz. Variation of signal amplitude should be less than ± 0.5 dB.
47. Repeat steps 35 through 46 until variation in signal amplitude is within limits.

PAGES 5-29 THROUGH 5-32:

2215A & Below

Paragraph 5-22. 3-dB Bandwidth Adjustment
In the NOTE following step 5, change A8R120* to A8R95*.
In step 6, change A8R116* to A8R89*.
In the NOTE following step 22, change A8R111* to A8R78*.

PAGES 5-40 THROUGH 5-44:

2142A & Below

Paragraph 5-26. Log Amplifier Log and Linear Adjustments
Replace Paragraph 5-26 with Paragraph 7-8, LOG AMPLIFIER LOG AND LINEAR
ADJUSTMENT (2142A & BELOW) included in this Manual Backdating supplement.

ADJUSTMENTS

7-8. LOG AMPLIFIER LOG AND LINEAR ADJUSTMENT (2142A & BELOW)

REFERENCE

A14 and A15 Schematics

DESCRIPTION

10 dB/DIV and LIN are adjusted for correct steps and full-screen display translations.

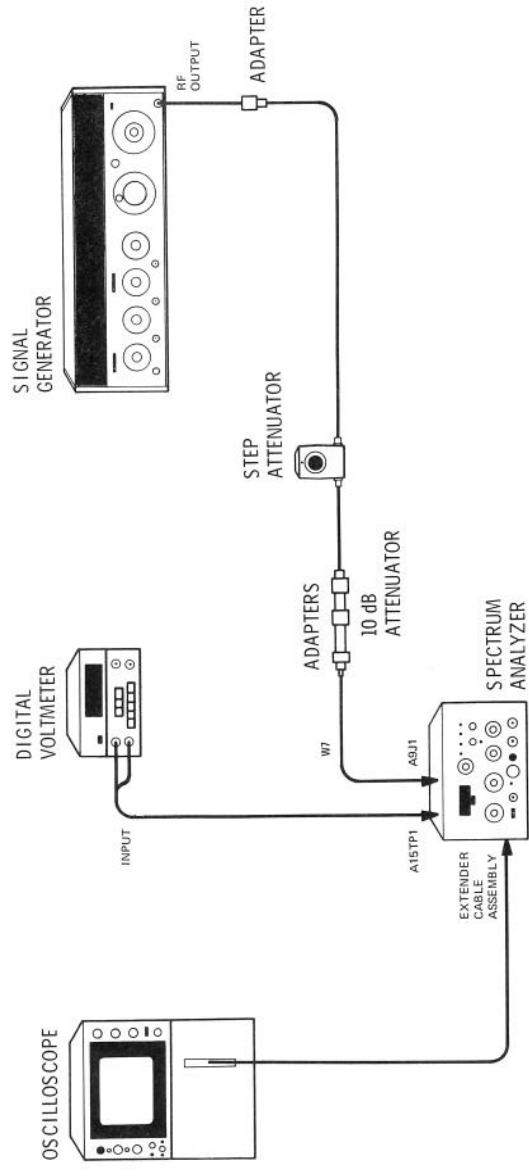

FIGURE 7-4. LOG AMPLIFIER ADJUSTMENT TEST SETUP (2142A & BELOW)

EQUIPMENT

Signal Generator	HP 8640B
Digital Voltmeter	HP 34740A/34702A
10 dB Attenuator	HP 8491A, Option 010
Step Attenuator (10 dB/step)	HP 355D
Adapter, Type N Male on one end, BNC Female on other end (2 required)	HP 1250-0780
Adapter, Type N Female on both ends	HP 1250-0777
Adapter, Type N Male on one end, SMC Male on other end	HP 1250-1023

ADJUSTMENTS

7-8. LOG AMPLIFIER LOG AND LINEAR ADJUSTMENT (2142A & BELOW) (Cont'd)

PROCEDURE

1. Set spectrum analyzer controls as follows:

```

FREQ SPAN/DIV ..... 1 MHz
RESOLUTION BW ..... 300 KHz
OPTIMUM INPUT ..... -30 dBm
001: -25 dBm
002: +25 dBmV
REFERENCE LEVEL dBm ..... -50
002: 0 dBmV
10 dB/DIV - 1 dB/DIV - LIN ..... LIN
SWEEP TIME/DIV ..... AUTO
SWEEP TRIGGER ..... FREE RUN
    
```

2. Connect equipment as shown in Figure 7-4. Set signal generator frequency to 301.4 MHz and output level to -13 dBm. Remove W7P1 from Second IF assembly A10J2. Connect signal generator output through step attenuator, 10 dB attenuator, and adapters to W7P1.

NOTE

The 10 dB attenuator is included to compensate for the 10 dB of gain on A12 Step Gain assembly when the TEST-NORM switch is in TEST.

3. Set the TEST-NORM switch on A12 Step Gain assembly to the TEST position. Tune signal generator frequency for maximum signal amplitude on oscilloscope display with step attenuator set at 0 dB.
4. Set output level of signal generator for a digital voltmeter reading of 700 mV, with step attenuator set at 0 dB and REFERENCE LEVEL control set to -50 dBm.
002: 0 dBmV
5. Set 8558B REFERENCE LEVEL to -80 dBm and set step attenuator to 30 dB. Observe digital voltmeter reading.
002: -30 dBmV
6. Adjust A14R3 LIN GAIN for a digital voltmeter reading of 700 mV.
7. Repeat steps 4, 5, and 6 until the DVM reading in step 5 is 700 ± 2 mV.
8. Set 8558B REFERENCE LEVEL to -50 dBm and set step attenuator to 0 dB. Change REFERENCE LEVEL and step attenuator settings as shown in Table 7-4. If Deviation From Reference is not within the given limits, readjust A14R3.
002: Set REFERENCE LEVEL dBmV to 0 and set attenuator to 0 dB. REFERENCE LEVEL (dBmV) settings in Table 5-7 top to bottom are, 0, -10, -20, -30, -40.

ADJUSTMENTS

7-8. LOG AMPLIFIER LOG AND LINEAR ADJUSTMENT (2142A & BELOW) (Cont'd)

TABLE 7-4. LINEAR GAIN ADJUSTMENT LIMITS

Reference Level (dBm)	Step Attenuator Setting (dB)	Deviation From Reference
-50	0	Reference
-60	10	$\pm 0.2 \text{ DIV} \pm 20 \text{ mV}$
-70	20	$\pm 0.2 \text{ DIV} \pm 20 \text{ mV}$
-80	30	$\pm 0.2 \text{ DIV} \pm 20 \text{ mV}$
-90	40	$\pm 0.3 \text{ DIV} \pm 30 \text{ mV}$

9. Set 8558B REFERENCE LEVEL to 0 dBm and disconnect signal generator from step attenuator. Record offset reading (DVM). The offset should be less than +30 mV.
002: REFERENCE LEVEL, +50 dBmV
10. Reconnect signal generator as shown in Figure 7-3. Set 10 dB/DIV - 1 dB/DIV - LIN switch to 10 dB/DIV and set step attenuator to 40 dB.
11. Set output level of signal generator for a digital voltmeter reading of 400 mV plus offset recorded in step 9 (algebraic sum). (Example: If offset is -23 mV, set output level of signal generator for a DVM reading of 377 mV.)
12. Set step attenuator to 0 dB. Digital voltmeter should indicate 800 mV, plus offset (algebraic sum) $\pm 1 \text{ mV}$. If DVM reading is not within limits, adjust A14R2 LOG/LIN adjustment for a digital voltmeter reading of 800 mV, plus offset minus 50 percent of overshoot. Example: If DVM indicates 767 mV and should be indicating 777 mV (-10 mV overshoot), adjust A14R2 for a DVM reading of 777 mV minus -5 mV, or 782 mV.
13. Repeat steps 10, 11, and 12 until the digital voltmeter indicates 800 mV plus offset $\pm 1 \text{ mV}$ with no further adjustment of A14R2 in step 12.
14. Set the step attenuator to the positions shown in Table 7-5 and record DVM reading for each setting. Correct the DVM readings by algebraically adding the offset (recorded in step 9).
15. Readjust A14R2 if necessary to meet the limits in Table 7-5.
16. Set step attenuator to 0 dB and set output level of signal generator for a digital voltmeter reading of 800 mV plus offset (recorded in step 9) $\pm 1 \text{ mV}$.
17. Set 10 dB/DIV - 1 dB/DIV - LIN switch to LIN. The digital voltmeter should indicate the reading set in step 16 $\pm 25 \text{ mV}$. If it does, go to step 19. If it does not, or if log fidelity is not within limits, go to step 18 and select A14R16*.

ADJUSTMENTS

7-8. LOG AMPLIFIER LOG AND LINEAR ADJUSTMENT (2142A & BELOW) (Cont'd)

TABLE 7-5. LOG FIDELITY CHECK

Step Attenuator Setting (dB)	DVM Reading (mV)	DVM Reading Corrected For Offset		
		Min. (mV)	Actual (mV)	Max. (mV)
0	_____	799	_____	801
10	_____	697	_____	703
20	_____	596	_____	604
30	_____	496	_____	504
40	_____	395	_____	405
50	_____	294	_____	306
60	_____	193	_____	207
70	_____	92	_____	108

- Select A14R16* to obtain an output in step 17 within ± 25 mV of the reading set in step 16. Decreasing A14R16* 10 percent will increase the DVM reading approximately 30 mV in step 17.

NOTE

Log fidelity must be considered when selecting A14R16*. That is, if the DVM READING CORRECTED FOR OFFSET in Table 7-5 is greater than 100 mV for a STEP ATTENUATOR SETTING of 70 dB, A14R16* should be selected for a DVM reading greater than the reading set in step 16. If the READING CORRECTED FOR OFFSET is less than 100 mV, A14R16* should be selected for DVM reading less than the reading set in step 16.

- Set output level of signal generator for a digital voltmeter reading of 800 mV plus offset (algebraic sum) ± 1 mV.
- Set 8558B 10 dB/DIV - 1 dB/DIV - LIN switch to 10 dB/DIV and adjust A14R2 LOG/LIN adjustment for a digital voltmeter reading of 800 mV plus offset.
- Repeat step 14 to recheck the log fidelity.
- Set the 8558B REFERENCE LEVEL dBm control to -50 . Set the 10 dB/DIV - 1 dB/DIV - LIN switch to 1 dB/DIV.
002: 0 dBmV
- Set the step attenuator to 0 dB and set output level of signal generator for a digital voltmeter reading of 700 mV (do not include offset).
- Set the 8558B REFERENCE LEVEL dBm control to -90 and the step attenuator to 40 dB. Adjust A14R1 LOG GAIN adjustment for a digital voltmeter reading of 700 mV.
002: -40 dBmV

ADJUSTMENTS

7-8. LOG AMPLIFIER LOG AND LINEAR ADJUSTMENT (2142A & BELOW) (Cont'd)

25. Change REFERENCE LEVEL and step attenuator settings as shown in Table 7-6. Deviation From Reference should not exceed the given limits.
002: REFERENCE LEVEL (dBmV) settings, top to bottom are, 0, -10, -20, -30, -40.
26. Return the TEST-NORM switch on A12 assembly to the NORM position.

TABLE 7-6. LOG GAIN ADJUSTMENT LIMITS

Reference Level (dBm)	Step Attenuator Setting (dB)	Deviation From Reference
-50	0	Reference
-60	10	± 0.3 DIV ± 30 mV
-70	20	± 0.3 DIV ± 30 mV
-80	30	± 0.3 DIV ± 30 mV
-90	40	± 0.3 DIV ± 30 mV

PAGES 5-45 THROUGH 5-47:

2215A & Below **Paragraph 5-27. Sweep Time Per Division Adjustment**
In step 3, change A8R2 to A8R7.
In step 7, change 5 ms to 2 ms (in 2 places).
In step 9, change 5 ms to 2 ms (in 1 place).
In step 10, change 5 ms to 2 ms (in 1 place).

PAGE 6-5:
2145A & Below

Table 6-3. Replaceable Parts
Substitute Table 7-3 (2145A & BELOW) of this Manual Backdating supplement
for the list of Accessories and Chassis Parts shown in Table 6-3.

TABLE 7-3. REPLACEABLE PARTS (2145A & BELOW)

Reference Designation	HP Part Number	C D	Qty	Description	Mfr Code	Mfr Part Number
A11	11593A	7	1	ACCESSORIES SUPPLIED	28480	11593A
	1250-0780	5	1	TERMINATION, 50 OHM	28480	1250-0780
	5020-8565	7	1	ADAPTER, TYPE N MALE TO BNC FEMALE	28480	5020-8565
	5020-8566	8	1	OVERLAY, 180 SERIES SCOPES	28480	5020-8566
	5020-8567	9	1	OVERLAY, 181 SERIES SCOPES	28480	5020-8567
	04558-60131	9	1	OVERLAY, 182 SERIES SCOPES	28480	04558-60131
				KIT, SIDE STOP		
				CHASSIS PARTS		
	P1	08558-60117	1	REAR-PANEL INTERCONNECT (PREWIRED)	28480	08558-60117
	R1	2100-3593	8	RESISTOR-VAR PREC W/CP 10-TRN 5K 10%	28480	2100-3593
R2	2100-3452	8	RESISTOR-VAR PREC W/CP 10-TRN 10K 10%	28480	2100-3452	
R3	2100-3485	1	RESISTOR-VAR PREC W/CP 10-TRN 5K 1%	28480	2100-3485	
R4	2100-3485	1	RESISTOR-VAR CONTROL W/CP 10K 5% LIN	28480	2100-3485	
R5	2100-3317	4	RESISTOR-VARIABLE W/SW 50K +/-20% 10C*	28480	2100-3317	
R6	2100-3317	4	RESISTOR-VARIABLE W/SW 50K +/-20% 10C*	28480	2100-3317	
S1	3101-0044	1	SWITCH-PR SPST-ND WDM .5A 115VAC RED-BTN	28480	3101-0044	
U1	5086-7282	1	LIMITER, RF INPUT	28480	5086-7282	
W1	04558-60038	5	CABLE ASSY, INPUT, RF (SEE FIG. 6-1)	28480	04558-60038	
W2	08558-60031	8	CABLE ASSY, INPUT, RF (OPT. 001/002)	28480	08558-60031	
W3	04558-20071	2	NOT ASSIGNED	28480	04558-20071	
W4	04558-20090	5	CABLE ASSY, OUTPUT, L.O.	28480	04558-20090	
W5	04558-20073	4	CABLE ASSY, OUTPUT, 1ST I.F.	28480	04558-20073	
W6	04558-60047	6	CABLE ASSY, INPUT, 2ND I.F.	28480	04558-60047	
W7	04558-60048	7	CABLE ASSY, OUTPUT, 2ND I.F.	28480	04558-60048	
W8	04558-60046	7	CABLE ASSY, CAL OUTPUT	28480	04558-60046	
W9	04558-60074	9	CABLE ASSY, CAL OUTPUT (OPT. 001/002)	28480	04558-60074	
W10	04558-60037	4	CABLE ASSY, INTERCONNECT	28480	04558-60037	
W11	04558-60043	2	CABLE ASSY, OUTPUT, VERTICAL	28480	04558-60043	
W12	04558-60044	3	NOT ASSIGNED	28480	04558-60044	
W13	04558-60080	7	CABLE ASSY, YIG DRIVER	28480	04558-60080	
W14	04558-20117	7	CABLE ASSY, SECOND CONVERTER	28480	04558-20117	
W15	04558-20116	6	CABLE ASSY, ATTENUATOR TO LIMITER	28480	04558-20116	
			CABLE ASSY, LIMITER TO FIRST CONVERTER			

See introduction to this section for ordering information
 *Indicates factory selected value

PAGE 6-7/6-8:

2147A & Below

Figure 6-2. Mechanical Chassis Parts

Change Reference Designator 31 to HP Part Number 08558-00089, Check Digit 9, COVER-BANDWIDTH FILTER #1.

Change Reference Designator 33 to HP Part Number 08558-00087, Check Digit 9, COVER-BANDWIDTH FILTER #2.

2145A & Below

Substitute Figure 7-1 (2145A & BELOW) of this Manual Backdating supplement for Figure 6-2, Mechanical Chassis Parts.

Reference Designation	HP Part Number	C D	Qty	Description	Mfr Code	Mfr Part Number
1	08558-0002	7	1	MECHANICAL CHASSIS PARTS	28480	08558-0002
2	08558-0004	9	1	PANEL, FRONT, SUR	28480	08558-0004
3	08558-0005	0	1	GUSSET, LEFT	28480	08558-0005
4	08558-0003	0	1	GUSSET, RIGHT	28480	08558-0003
5	08558-20039	2	1	GUIDE RAIL, REAR	28480	08558-20039
6	08558-20040	5	1	GUIDE RAIL, LEFT	28480	08558-20040
7	08558-20037	0	1	GUIDE RAIL, RIGHT	28480	08558-20037
8	08558-20036	0	1	EXTRUSION, END PLATE ENCLOSURE	28480	08558-20036
9	08558-20051	7	2	EXTRUSION, CIRCUIT ENCLOSURE, TAPPED (4)	28480	08558-20051
10	08558-20038	1	1	EXTRUSION, CIRCUIT ENCLOSURE	28480	08558-20038
11	08558-20038	1	1	EXTRUSION, ENCLOSURE DIVIDER	28480	08558-20038
12	08558-20092	6	1	HOUSING, LATCH(FOR INSTRUMENTS WITH SERIAL PREFIX 1334A & BELOW, SEE SECTION VII)	28480	08558-20092
13	08558-00030	1	1	SHAFT, LATCH	28480	08558-00030
14	08558-20041	6	1	INSULATOR, BOTTOM GUIDE RAIL	28480	08558-20041
15	08558-20027	6	1	GUIDE RAIL, BOTTOM	28480	08558-20027
16	08558-20023	9	1	BOARD, VERTICAL OUTPUT CONNECTOR	28480	08558-20023
17	2200-0055	3	1	SCREW-TPG 4-40 .375-IN-LG R2 DEG	28480	2200-0055
18	2200-0104	3	17	SCREW-WACH 4-40 .125-IN-LG R2 DEG	28480	2200-0104
19	2360-0210	0	4	SCREW-WACH 4-40 .25-IN-LG R2 DEG	28480	2360-0210
20	0624-0268	4	40	SCREW-TPG 4-40 .375-IN-LG PAN-HD-POZI	28480	0624-0268
21	0624-0206	2	1	SCREW-TPG 4-40 .25-IN-LG PAN-HD-POZI	28480	0624-0206
22	2200-0103	2	4	SCREW-WACH 4-40 .125-IN-LG PAN-HD-POZI	28480	2200-0103
23	2360-0115	4	1	SCREW-WACH 4-40 .25-IN-LG PAN-HD-POZI	28480	2360-0115
24	2200-0170	3	2	SCREW-WACH 4-40 .312-IN-LG PAN-HD-POZI	28480	2200-0170
25	0380-0006	2	2	SCREW-WACH 4-40 .625-IN-LG R2 DEG	28480	0380-0006
26	2260-0003	7	2	SPACER-RAD .375-IN-LG .18-IN-ID	28480	2260-0003
27	2200-0107	6	2	NUT-HEX-PLSTC LKG 4-40-TMO .141-IN-TMK	28480	2200-0107
28	2200-0164	5	2	SCREW-WACH 4-40 .375-IN-LG PAN-HD-POZI	28480	2200-0164
29	2200-0166	9	2	SCREW-WACH 4-40 .188-IN-LG UNCT R2 DEG	28480	2200-0166
30	08558-00086	7	3	SCREW-WACH 4-40 .438-IN-LG R2 DEG	28480	08558-00086
31	08558-00089	0	1	COVER, LOG AMPLIFIER	28480	08558-00089
32	08558-00088	9	2	COVER, BANDWIDTH FILTER NO. 1	28480	08558-00088
33	08558-00087	8	1	COVER, BANDWIDTH FILTER NO. 2	28480	08558-00087
34	08558-20096	0	1	COVER, STEP GAIN	28480	08558-20096
35	08558-20093	7	1	EXTRUSION, CIRCUIT ENCLOSURE, TAPPED (8)	28480	08558-20093

FIGURE 7-1. MECHANICAL CHASSIS PARTS (1 OF 2) (2145A & BELOW)

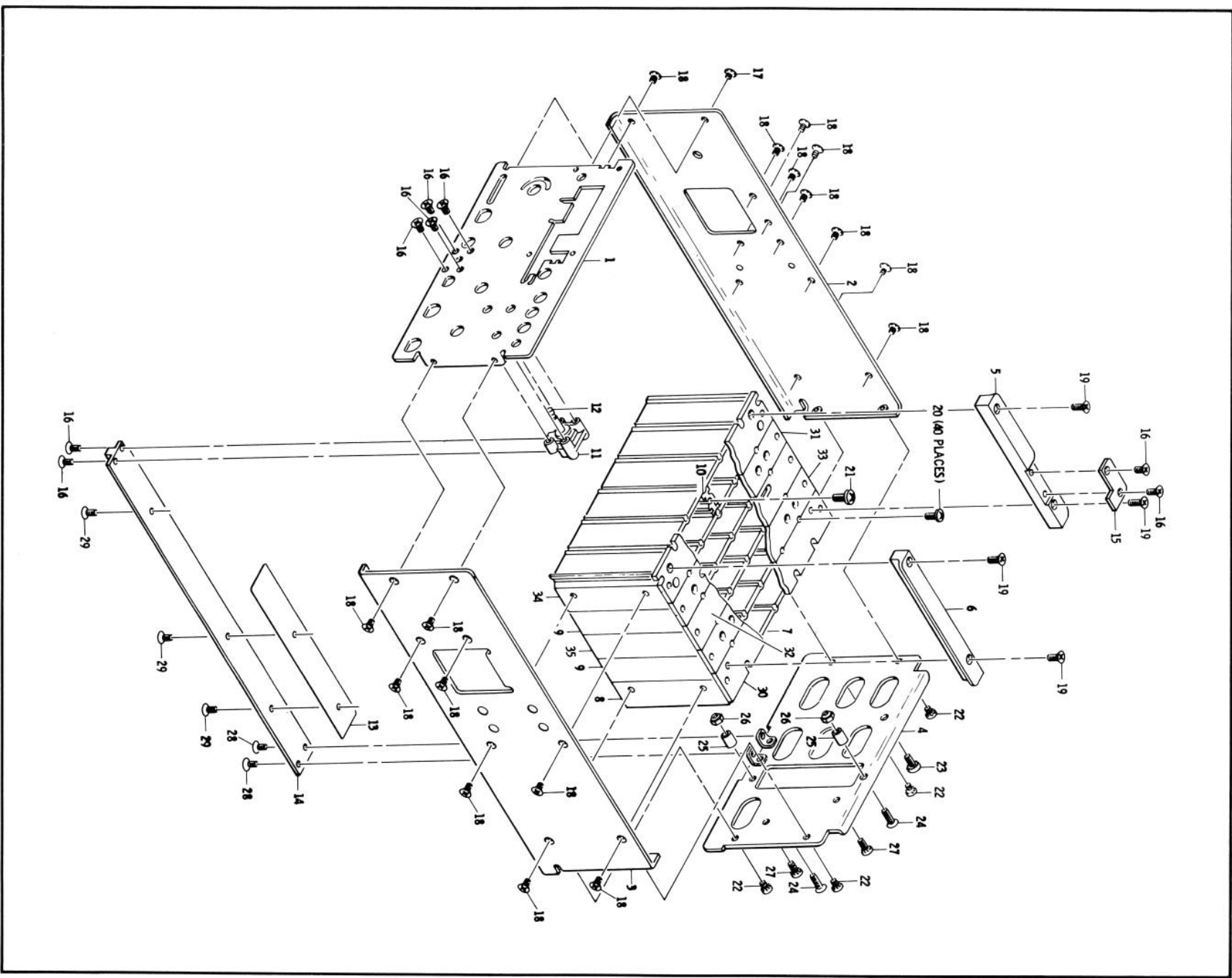

FIGURE 7-1. MECHANICAL CHASSIS PARTS (2 OF 2) (2145A & BELOW)

PAGE 8-25:
2145A & Below

Table 8-3. A1A2 Replaceable Parts
Insert Table 7-2 (2145A & BELOW), included in this Manual Backdating supplement, so that it precedes the A1A2 list.

TABLE 7-2. REPLACEABLE PARTS (2145A & BELOW)

Reference Designation	HP Part Number	C	Qty	Description	Mfr Code	Mfr Part Number
A1				DIGITAL PANEL METER ASSEMBLY		
A1MP1	08558-00090	3	1	BRACKET, LEFT-HAND	28480	08558-00090
A1MP2	08558-00091	4	1	BRACKET, RIGHT-HAND	28480	08558-00090
A1MP3	08558-20130	4	2	DPM DISPLAY MOUNT	28480	08558-20130
A1MP4	08558-20130	4	2	DPM DISPLAY MOUNT	28480	08558-20130
A1MP5	2200-0107	6	4	SCREW-MACH 4-40 .375-IN-LG PAN-HD-POZI	28480	2200-0107
A1MP6	2200-0107	6	4	SCREW-MACH 4-40 .375-IN-LG PAN-HD-POZI	28480	2200-0107
A1MP7	2200-0107	6	4	SCREW-MACH 4-40 .375-IN-LG PAN-HD-POZI	28480	2200-0107
A1MP8 THRU A1MP16	0520-0174	3	8	SCREW-MACH 2.56 .25-IN-LG PAN-HD-POZI	28480	0520-0174
A1MP17 THRU A1MP20	0610-0001	6	4	NUT-HEX DBL-CHAM 2.56 THD .062-IN-THK	28480	0610-0001
A1MP21 THRU A1MP24	2190-0890	1	4	WASHER-LK HLCL NO. 2 .088-IN-ID	28480	2190-0890
A1MP25 THRU A1MP28	3050-0098	6	4	WASHER-FL MTLCL NO. 2 .084-IN-ID	28480	3050-0098
A1A1	08558-60124	0	1	DPM DISPLAY	28480	08558-60124
A1A1DS1	1990-0619	7	4	DISPLAY-NUM-SEG 1-CHAR .3-H	28480	5082-7613
A1A1DS2	1990-0619	7	4	DISPLAY-NUM-SEG 1-CHAR .3-H	28480	5082-7613
A1A1DS3	1990-0619	7	4	DISPLAY-NUM-SEG 1-CHAR .3-H	28480	5082-7613
A1A1DS4	1990-0619	7	4	DISPLAY-NUM-SEG 1-CHAR .3-H	28480	5082-7613
A1A1W1	08558-60130	8	1	CABLE ASSY RIBBON, DPM	28480	08558-60130
A1A1XDS1	1200-0693	4	4	SOCKET-IC 10-CONT DIP DIP SLDR	51167	10-513-11
A1A1XDS2	1200-0693	4	4	SOCKET-IC 10-CONT DIP DIP SLDR	51167	10-513-11
A1A1XDS3	1200-0693	4	4	SOCKET-IC 10-CONT DIP DIP SLDR	51167	10-513-11
A1A1XDS4	1200-0693	4	4	SOCKET-IC 10-CONT DIP DIP SLDR	51167	10-513-11

PAGES 8-29 THROUGH 8-49/8-50: A2 FRONT SWITCH ASSEMBLY**Figure 8-18. Front Switch Assembly**

2145A & Below
 Replace Figure 8-18 with Figure 7-2 (2145A & BELOW) of this Manual Backdating supplement.

In Figure 7-2:

Change Item 53 to HP Part Number 08558-20052, Check Digit 9.
 Change Item 57 to HP Part Number 08552-20053, Check Digit 0.

OTHER THAN those

listed below:

04747, 04918, 04993,
 05158, 05160, 05172,
 05228, 05229, 05252,
 05281, 05297, 05300
 thru 05307, 05311,
 05312, 05313, 05316,
 05318, 05320.

Figure 8-19. Front Switch Board Assembly A2A1, Component Locations

2145A & Below
 Delete Figure 8-19.

Figure 8-20. A2 Front Switch Assembly, Schematic Diagram

2245A & Below
 Change the source of the 92 wire going to block (B) (TUNING) from "A16J2 +15V" to "A16J1-41 +15V".

2145A & Below
 Replace Figure 8-20 with Figure 7-3 (2145A & BELOW), included in this Manual Backdating supplement.

Reference Designation	HP Part Number	C	D	Qty	Description	Mfr Code	Mfr Part Number
1	08558-00036	7	1	1	FRONT PANEL ASSEMBLY	28480	08558-00036
2	3030-0007	5	33	1	KNDB, REF LEVEL FINE	28480	3030-0007
3	0510-0089	A	1	1	SCREW-SET 4-40 .125-IN-LG SMALL CUP-PT	28480	0510-0089
4	08558-00017	4	1	1	RETAINING-RING RSC EXT .188-IN-DIA BE-CU	28480	08558-00017
4	08558-00055	0	1	1	DISC, INDEX	28480	08558-00055
5	3050-0032	8	1	1	DISC, INDEX (OPTION 002)	28480	3050-0032
6	08558-00050	1	1	1	WASHER-FL MTL NO. 8 .189-IN-ID	28480	08558-00050
6	08558-00072	7	1	1	KNDB, REF LEVEL	28480	08558-00072
7	3030-0022	4	10	1	KNDB, REF LEVEL (OPTION 002)	28480	3030-0022
8	08558-20060	9	1	1	SCREW-SET 6-32 .125-IN-LG SMALL CUP-PT	28480	08558-20060
9	08558-00018	5	1	1	NUT	28480	08558-00018
10	08558-00038	8	1	1	POT/TP, ATTENUATOR	28480	08558-00038
11	08558-00051	2	1	1	KNDR, DIAL, RESOLUTION	28480	08558-00051
12	00180-67402	9	1	1	KNDR, FREQUENCY	28480	00180-67402
13	08558-00043	6	1	1	KNDR, FINE TUNING	28480	08558-00043
14	08558-00003	2	1	1	KNDR, COARSE TUNING	28480	08558-00003
15	2950-0043	8	1	1	WINDOW, RPM	28480	2950-0043
16	2190-0016	3	13	1	NUT-HEX-DBL-CHAM 3/4-32-TMD .094-IN-THK	28480	2190-0016
17	1410-0721	4	1	1	WASHER-LK INTL T 3/8 IN .377-IN-ID	28480	1410-0721
18	08558-40001	0	1	1	RUSHING-PNL .265-ID .47-LG 3/8-32-TMD	28480	08558-40001
19	2200-0761	2	3	1	SLIDER, START-CENTER	28480	2200-0761
20	08558-00019	6	3	1	SCREW-MACH 4-40 2.75-IN-LG PAN-HD-POZI	28480	08558-00019
21	0360-0411	3	14	1	DETENT, ATTENUATOR	28480	0360-0411
22	08558-20047	2	4	1	SPACER-RND .5-IN-LG .114-IN-ID	28480	08558-20047
23	08558-20051	6	1	1	BUSHING, PANEL	28480	08558-20051
24	1410-0006	8	6	1	SHAFT, REF LEVEL	28480	1410-0006
25	1440-0576	4	5	1	RALL-98G TYPE .1875-DIA GRAB-50 SST	28480	1440-0576
26	08558-60060	4	6	1	SPRING-CPRSN .18-IN-ID .312-IN-OD-ALG MUM	28480	08558-60060
27	1480-0367	1	1	1	HUB ASSEMBLY .18-IN-ID .312-IN-OD-ALG MUM	28480	1480-0367
28	1480-0059	6	10	1	PTN-ROLL .062-IN-DIA .25-IN-LG STL	28480	1480-0059
29	08558-40011	2	1	1	ROTOR, ATTENUATOR DRIVE	28480	08558-40011
30	08558-40008	7	1	1	GEAR, 45 TEETH	28480	08558-40008
31	0510-0015	0	2	1	RETAINING-RING EAR EXT .125-IN-DIA STL	28480	0510-0015
32	08558-60046	5	2	1	CABLE, CAL OUTPUT	28480	08558-60046
32	08558-60074	9	2	1	CABLE, CAL OUTPUT, 75 OHM (OPT. 001/002)	28480	08558-60074
33	2200-0509	2	1	1	SCREW-MACH 4-40 1.925-IN-LG PAN-HD-POZI	28480	2200-0509
34	2200-0125	6	1	1	SCREW-MACH 4-40 1.5-IN-LG PAN-HD-POZI	28480	2200-0125
35	08558-00024	3	2	1	DETENT, SLEEP TIME	28480	08558-00024
36	08558-20050	7	1	1	SHAFT, SLEEP WIDTH	28480	08558-20050
37	08558-20066	5	1	1	ROTOR, FREQUENCY SPAN	28480	08558-20066
38	08558-20069	2	1	1	BUSHING, SLOTTED	28480	08558-20069
39	1480-1376	1	1	1	SPRING-TURN MUM	28480	1480-1376
40	0326-0188	1	1	1	SCREW-MACH 4-40 .125-IN-LG .114-IN-ID	28480	0326-0188
41	0326-0188	1	2	1	SCREW-MACH 4-40 .125-IN-LG .114-IN-ID	28480	0326-0188
42	0380-0487	3	2	1	SPACER-RND .025-IN-LG .068-IN-ID	28480	0380-0487
43					NOT ASSIGNED		
44	0610-0002	7	2	1	NUT-HEX-DBL-CHAM 2-56-TMD .062-IN-THK	28480	0610-0002
45	08558-20002	9	1	1	BOARD, FRONT SWITCH	28480	08558-20002
46	08558-40005	4	3	1	ROTOR, DOUBLE CONTACT	28480	08558-40005
47	3050-0017	9	3	1	WASHER-FL MTL 1/4 IN .26-IN-ID	28480	3050-0017
48	1480-0532	0	1	1	SPRING-CPRSN .54-IN-ID .45-IN-OD-ALG MUM	28480	1480-0532
49	2200-0165	6	4	1	SCREW-MACH 4-40 .25-IN-LG 62 DEG	28480	2200-0165
50	08558-00020	9	1	1	DETENT, IF GAIN	28480	08558-00020
51	08558-20061	0	1	1	LOCKOUT, ROTATING	28480	08558-20061
52	08558-20062	1	1	1	LOCKOUT, FIXED	28480	08558-20062
53	08558-20052	9	1	1	SHAFT, FIXED	28480	08558-20052
54	2800-0002	6	1A	1	NUT-HEX-DBL-CHAM 4-40-TMD .062-IN-THK	28480	2800-0002
55	0360-0413	5	3	1	SPACER-RND 1.25-IN-LG .114-IN-ID	28480	0360-0413
56	08558-00022	1	1	1	CRANK, SLOTTED	28480	08558-00022
57	08558-20053	0	1	1	SHAFT, REF LEVEL FINE	28480	08558-20053
58	1490-0841	7	1	1	COUPLER-RCD .375-LG BR5	28480	1490-0841
59	2950-0006	3	4	1	NUT-HEX-DBL-CHAM 1/4-32-TMD .094-IN-THK	28480	2950-0006
60	2190-0027	6	6	1	WASHER-LK INTL T 1/4 IN .258-IN-ID	28480	2190-0027
61	08558-00021	0	1	1	PLATE, LEVEL POT	28480	08558-00021
62	2190-0019	6	1	1	WASHER-LK HLCL NO. 4 .115-IN-ID	28480	2190-0019
63	08558-20054	1	1	1	SHAFT, ATTENUATOR DRIVE	28480	08558-20054
64	1430-0036	6	2	1	GEAR-WIT 16-PT 32-DP 20-DEG PA BR5	28480	1430-0036
65					NOT ASSIGNED		
66	08558-00061	2	1	1	BRACKET, ATTENUATOR	28480	08558-00061
67	3050-0105	6	4	1	WASHER-FL MTL NO. 4 .125-IN-ID	28480	3050-0105
68					NOT ASSIGNED		
69	08558-20030	3	1	1	BOARD, REAR SWITCH	28480	08558-20030
70	2200-0143	0	2	1	SCREW-MACH 4-40 .375-IN-LG PAN-HD-POZI	28480	2200-0143
71	08558-40004	3	1	1	ROTOR, SINGLE CONTACT	28480	08558-40004
72	08558-00025	4	1	1	DETENT, BANDWIDTH	28480	08558-00025

FIGURE 7-2. FRONT PANEL ASSEMBLY (1 OF 3) (2145A & BELOW)

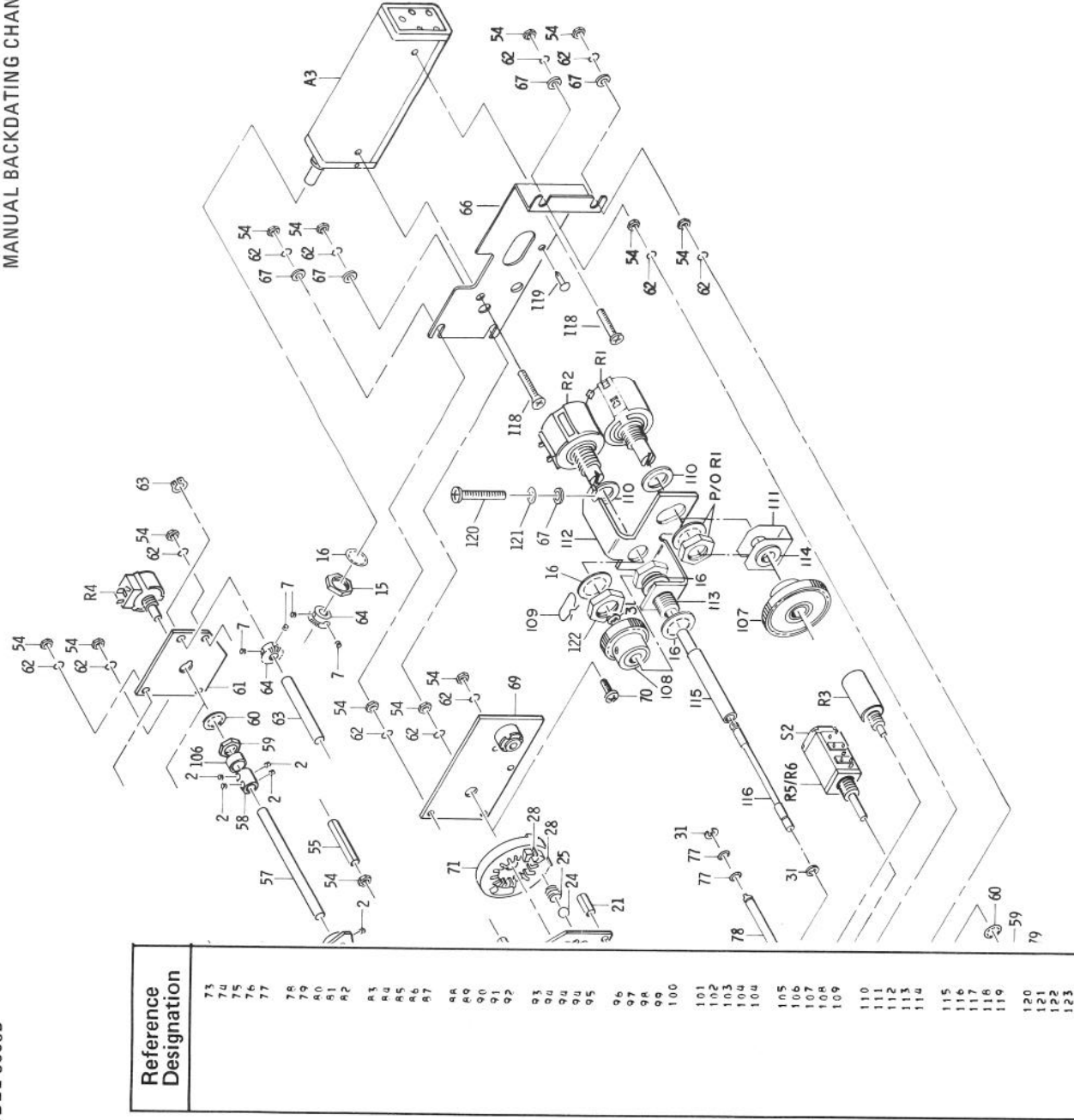

FIGURE 7-2. FRONT PANEL ASSEMBLY (3 OF 3) (2145A & BELOW)

NOTES

- EXCEPT FOR W9 INTERCONNECT CABLE ASSY, REFERENCE DESIGNATORS WITHIN THIS ASSEMBLY ARE ABBREVIATED. PREFIX ABBREVIATION WITH ASSEMBLY NUMBER FOR COMPLETE REFERENCE DESIGNATOR.
- UNLESS OTHERWISE INDICATED:
RESISTANCE IN OHMS (Ω)
CAPACITANCE IN MICROFARADS (μ F)
INDUCTANCE IN MICROHENRIES (μ H)

3. MNEMONIC TABLE:

MNEMONIC	DEFINITION
BW1-5	BANDWIDTH CONTROL LINES
FS1-6	FREQUENCY SPAN CONTROL LINES
IFG1-6	IF GAIN CONTROL LINES
ST1-6	SCAN TIME CONTROL LINES (ST6 ENABLES FAST SCAN TIMES)
ST - CTR	START - CENTER
-10 VTV	-10V TEMP VARIABLES

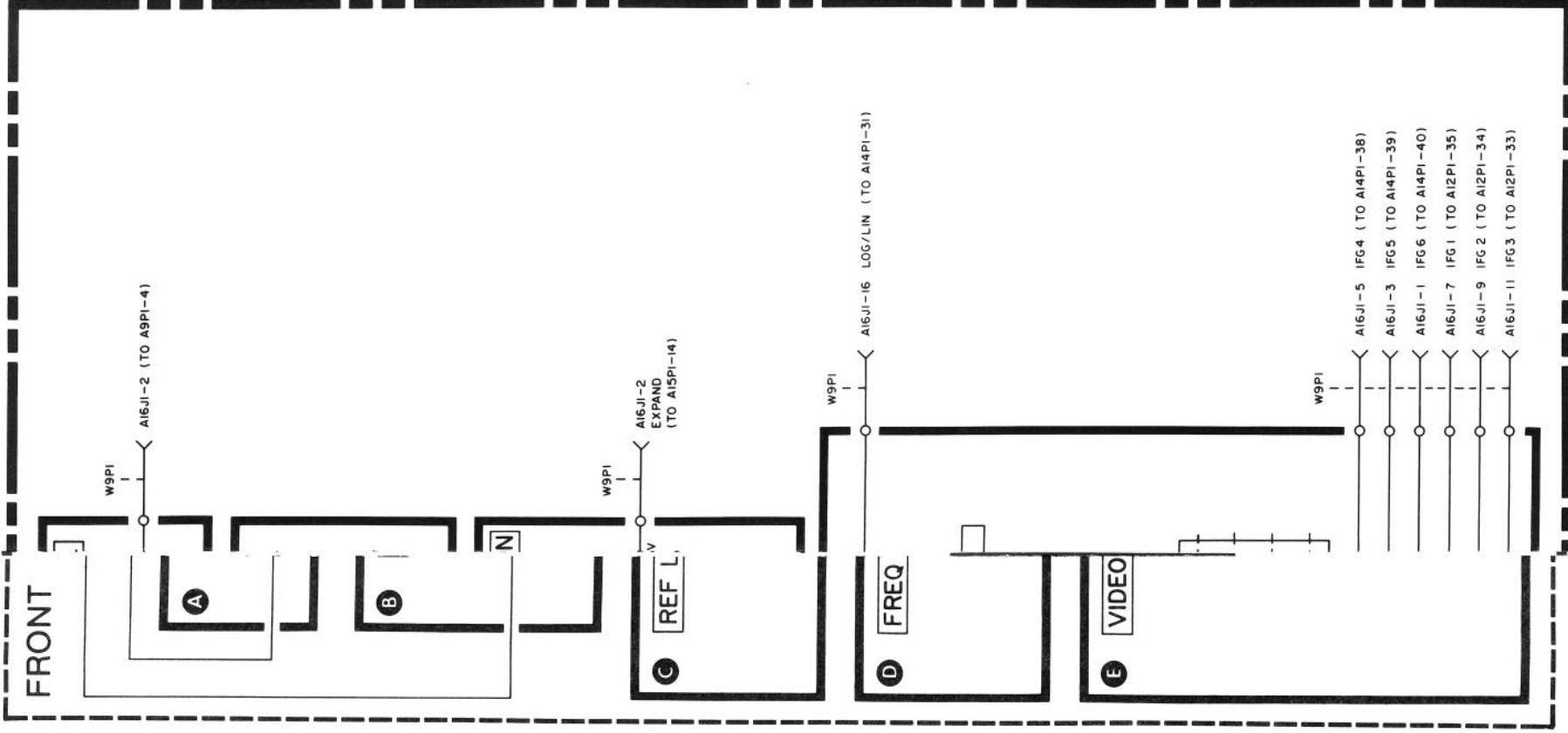

FIGURE 7-3. A2 FRONT SWITCH ASSEMBLY, SCHEMATIC DIAGRAM (2145A & BELOW)

A2

PAGES 8-51 THROUGH 8-59/8-60: RF SECTION

2332A & Below **Table 8-6. RF Section, Replaceable Parts**
Change A5MP2 to HP Part Number 0858-20121, Check Digit 3.
Add A5MP24, Check Digit 7, Capacitor Outer Element.

2332A & Below **Figure 8-24. A5 Second Converter, Component Locations**
Add A5MP24 as the outer element of A5MP25 in the center assembly.

PAGES 8-61 THROUGH 8-69/8-70: A7 FREQUENCY CONTROL ASSEMBLY

2215A & Below

Table 8-7. A7 Frequency Control, Replaceable Parts
Change A7R12, A7R19, and A7R23 to HP Part Number 0683-1555, Check Digit 0,
RESISTOR 1.5M 5% .25W FC TC+-900/+1100.

2215A & Below

Figure 8-27. A7 Frequency Control, Schematic Diagram
In function block (D), change R12 to 1.5M.
In pin-out table P1, change designator for pin 31 to read GND3 for the
signal, and A8P1-35 for TO/FROM.
In function block (O), add a ground line to P1-31(GND3).
In the mnemonic table (NOTE 8), add the mnemonic "GND3", Ground (to A8
Sweep Generator).

PAGES 8-71 THROUGH 8-85/8-86: A8 SWEEP GENERATOR/BANDWIDTH CONTROL ASSEMBLY

A8 Sweep Generator/Bandwidth Control, Circuit Description

2215A & Below Replace the A8 circuit description with the A8 SWEEP CIRCUIT DESCRIPTION (2215A & BELOW) included in this Manual Backdating supplement.

Table 8-8. A8 Sweep Generator, Replaceable Parts

2332A09675 & Below Change A8R5 to HP Part Number 0757-0459, Check Digit 8, RESISTOR 56.2K 1% .125W FTC=0+-100.
 Change A8R6 to HP Part Number 0698-3152, Check Digit 8, RESISTOR 3.48K 1% .125W FTC=0+-100.
 Change A8R12 to HP Part Number 0698-3446, Check Digit 3, RESISTOR 383 1% .125W FTC=0+-100.

2226A & Below Change A8Q8 to HP Part Number 1853-0316, Check Digit 1, TRANSISTOR J-FET, MTCHE PR N-CHAN D-MODE.

2215A & Below Replace Table 8-8 with Table 7-8 (2215A & BELOW) included in this section.

Figure 8-29. A8 Sweep Generator, Component Locations

2215A & Below Replace Figure 8-29 with Figure 7-15 (2215A & BELOW) included in this Manual Backdating supplement.

Figure 8-30. A8 Sweep Generator, Schematic Diagram (1 of 2)

2332A09675 & Below

In function block (P), Change the value of R5 to 56.2K ohms.
 In function block (P), change the value of R6 to 3.48K ohms.
 In function block (F), change the value of R12 to 383 ohms.
 In the lower left corner of the schematic, change the Serial Prefix to 2226A.

2226A & Below Change A8 to HP Part Number 08558-60153.

2215A & Below Replace Figure 8-30 (1 of 2) with Figure 7-16 (1 of 2) (2215A & BELOW) included in this Manual Backdating supplement.

Figure 8-30. A8 Sweep Generator, Schematic Diagram (2 of 2)

2226A & Below

Change A8 to HP Part Number 08558-60153.
 In function block (O), add the subscript "1" next to the ground symbol in the following locations:
 The source of Q23.
 The source of Q25.
 The source of Q29.
 The emitter of Q48.

2215A & Below

Replace Figure 8-30 (2 of 2), with Figure 7-16 (2 of 2) (2215A & BELOW) included in this Manual Backdating supplement.

A8 SWEEP GENERATOR CIRCUIT DESCRIPTION (2215A & BELOW)**General Description**

The Sweep Generator Assembly generates a -5 volt to $+5$ volt linear sweep voltage. The sweep voltage controls the frequency of YIG oscillator Assembly A6, and also controls the horizontal deflection of the CRT beam. The SWEEP TIME/DIV control varies from 0.1 mSEC/DIV to 10 SEC/DIV so the full scan sweep time varies from 1 ms to 100 sec. The sweep may be synchronized with either the video input or the line voltage. Manual and free run modes are also provided. A single sweep may be started or stopped with the front panel TRIGGER switch. A retrace voltage is generated and applied to Vertical Driver and Blanking Assembly A15.

Sheet 2 of the A8 schematic (Figure 7-16) shows the resolution bandwidth control circuit, the video filter, the sweep attenuator circuit, and the $+V$ sweep offset circuit. The resolution bandwidth control circuit has three purposes. First it provides the bandwidth filter control current to the PIN diodes on Bandwidth Filter Assemblies A11 and A13. Second, it provides current to the sweep generator current source (AST line) to control the AUTO sweep time circuit as a function of resolution bandwidth. Third, it switches in the proper capacitor for the RC lowpass video filter to provide video filtering as a constant percentage of resolution bandwidth. The sweep attenuator circuit attenuates the sweep ramp to Frequency Control Assembly A7 in proportion to the FREQ SPAN/DIV selected. It also provides a current to the sweep generator current source (AST line) to control the automatic sweep time circuit as a function of frequency span per division. The $+V$ sweep offset circuit offsets the ramp voltage by 5 volts so the ramp voltage, when START frequency is selected, is from $0V$ to $+10V$ instead of $-5V$ to $+5V$.

Sweep Generator Circuit

The sweep ramp is generated in the following cycle. (See Figure 7-14.)

When transistor Q10 turns on, the sweep ramp is initiated. At the beginning of the sweep cycle, the voltage at TP3 is $-4V$ and dead-time capacitor C15 is charging toward $+15V$ through R33. When the anode voltage on CR11 reaches $+1.5V$, Q10 turns on and the TP5 voltage becomes $+3V$.

Pin 2 of U1 is at $-5V$ and comparator U1 toggles to its positive supply voltage of $+14.5V$. CR5 is now reverse biased. The current source can begin charging timing capacitors C3 and C4 positively, forming the positive slope of the sweep ramp.

As the sweep ramp level approaches $+5V$ at TP8, the U1 feedback circuit takes control, holding pin 2 of U1 at $2.68V$ and temporarily bringing pin 6 out of saturation. The anode voltage of zener diode VR1 equals the voltage at pin 6 minus $10V$:

$$E_{VR1} = E_{\text{pin 6}} - 10V$$

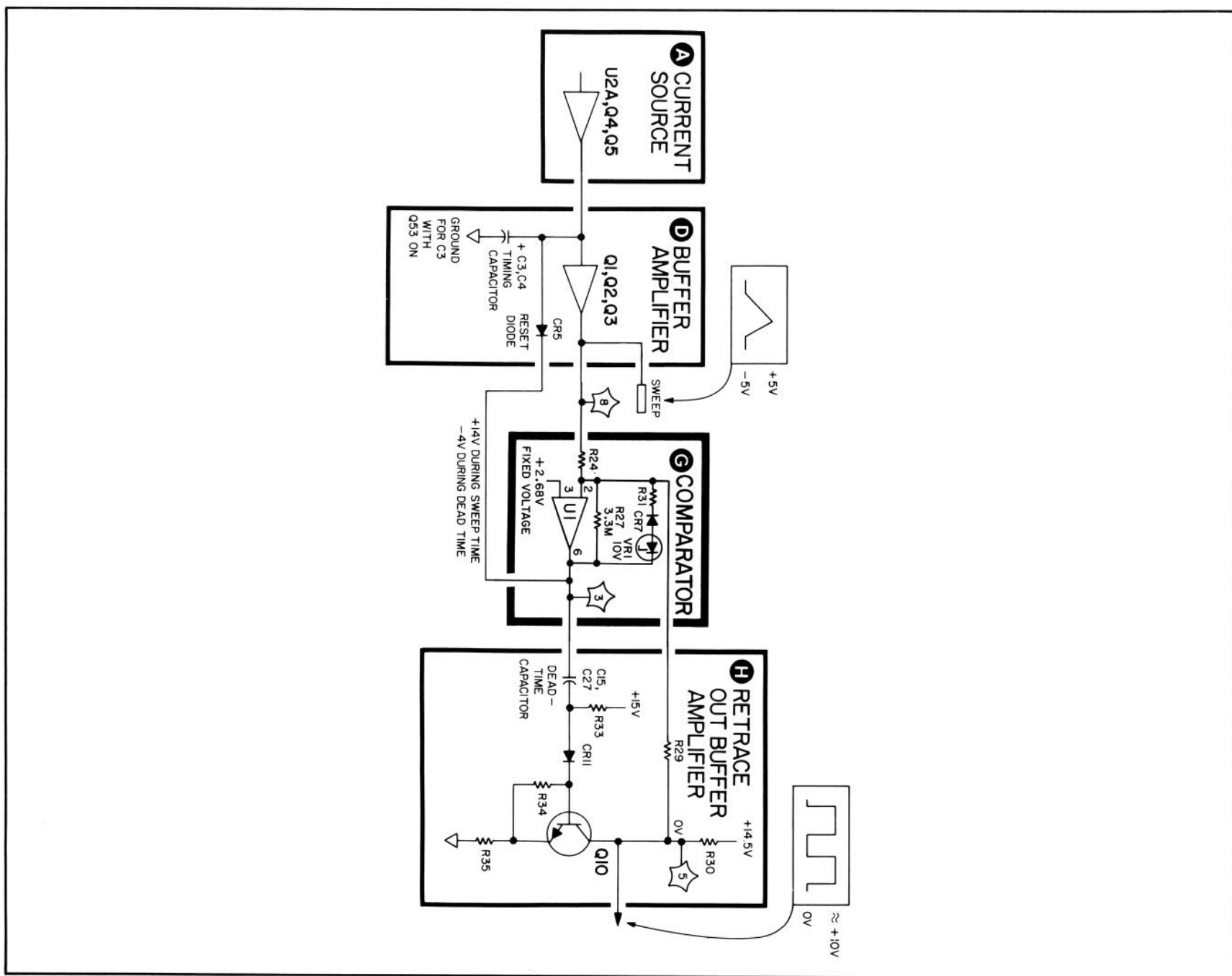

FIGURE 7-14. SIMPLIFIED SCHEMATIC OF SWEEP GENERATOR IN AUTO MODE (2215A & BELOW)

As the voltage at U1 pin 6 (TP3) decreases, the anode voltage of VR1 decreases. At some time (when the level of the sweep ramp at TP8 is +5V), the anode voltage of VR1 will no longer forward bias CR7, and the zener feedback loop opens. At this point, the 3.3 megohm feedback loop becomes active and U1 saturates again. The comparator toggles, this time toward the negative operational amplifier supply, and -4V appears at TP3.

The -4V at T3 forward biases CR5. Timing capacitors C3 and C4 discharge through CR5, forming the negative slope of the sweep ramp. Dead-time capacitor C15 discharges.

The endpoints of the sweep ramp at TP8, -5V and +5V, are controlled by the voltage divider R21, R24, R29, and R30 or R35, and by U1 and its feedback loops. U1 controls the ramp voltage as it maintains 2.68V at pin 2.

At the end of the ramp, when CR5 is forward biased, and the comparator output (pin 6 of U1) is approaching its negative supply, U1 uses Q1 and Q3 to maintain 2.68V at pin 2. Q10 is off, and the voltage divider R21, R24, R29, and R30 produces -5V at TP8.

At the beginning of the ramp, when CR5 is reverse biased, and the comparator output is approaching its positive supply, U1 again maintains 2.68V at pin 2. This time, Q10 is on, and voltage divider R21, R24, R29, and R35 produces +5V at TP8.

Fast/Slow Sweep Time Operation. The ST6 control line from Front Switch Assembly A2A1, selects timing and dead-time capacitors C3, C4, C5, and C27, to control fast and slow sweep times. If the same amount of charging current is supplied to a larger capacitor, it charges at a slower rate.

Timing capacitors C3 and C4 are used to provide fast and slow sweep operation. When a fast sweep time (ms/div) is selected at TIME/DIV switch A2A1S3, the ST6 (FAST SWEEP) control line is grounded, turning off Q55 and Q53. With Q53 off, C3 and C4 are in series and the timing capacitor becomes C4. With Q55 off, the +15V at R57 back biases CR9 and CR6, so C27 is switched out of the dead-time circuit. The dead-time (about 0.4 ms) is set by C15. In sweep times greater than 1 ms/div (or in AUTO sweep times), the ST6 (FAST SWEEP) control line is open, Q55 and Q53 are both on. With Q53 on, a ground is provided for C3 and it becomes the timing capacitor. CR6 and CR9 are on because of the conduction of Q55. C15 and C27 are in parallel, so the longer dead-time (about 7.5 ms) is set by C27.

When selecting FREE RUN mode (A2A1S4), +15 volts is routed to the voltage divider, R59 and R60, via the TRIG control line. CR10 is reversed biased.

FREE RUN TRIGGER Operation. The circuit free runs and Q10 conducts when U1 switches on and off at a time determined by the RC time constants.

VIDEO TRIGGER OPERATION. When the video mode is selected (VIDEO position on A2A1S4 switch), CR10 is forward biased by R59, and Q10 is off. The sweep ramp is generated by turning on Q10 with a negative pulse from the pulse shaper circuitry. The negative pulse is applied to the emitter of Q10.

The pulse shape consists of a Schmitt trigger (Q39 and Q40), a differentiator (C12 and R55), and an emitter follower (Q12). The Schmitt trigger produces a pulse which exists as long as the video trigger information on the SYNC line is above a certain dc level. When the TRIGGER switch is in VIDEO position, video information from Vertical Driver and Blanking Assembly A15 is routed through the switch to the base of Q40. Q40 is normally off and Q39 is conducting. During the positive portion of the SYNC signal, Q40 turns on, turning Q39 off. C7 accelerates the Q39 switching. When Q40 switches on, the negative change at the collector is differentiated by C12 and R55, and coupled through Q12 to the Q10 emitter. The negative pulse turns on Q10. CR8, R32, and VR1 keep Q10 on while the ramp is being generated. After the ramp is completed, the circuit returns to its dead-time state and another trigger is required to generate another sweep. Trigger pulses from Q40, which may occur during the sweep, have no effect since Q10 is already on.

LINE TRIG Operation The sweep may be synchronized with the ac line voltage in the same manner as described in VIDEO operation. With TRIGGER switch A2A1S4 in LINE position, the ac line from the mainframe power transformer is connected to the Schmitt trigger (Q40 and Q39) input. A16R2 and A16C2 on the motherboard attenuate the ac line signal to approximately 2 volts p-p and filter any line spikes.

SINGLE Sweep Trigger and Abort. Q10 is initially held off by R59 and CR10. Q9 is on, and voltage divider R37 and R38 charges C16 to +2.8V. When the trigger switch A2A1R4 is set to SINGLE sweep (spring-loaded position), +15V is applied to R62 turning on Q11. This shorts the positive end of C16 to ground and produces a negative pulse at the emitter of Q10. This turns Q10 on starting a sweep.

During the generation of a sweep, Q9 is off and the voltage divider R37 and R38 charges C16 to -4V. The sweep may be aborted (reset to -5V) by pressing the SINGLE switch to the spring-loaded position. This switches on Q11. The negative end of C16 is shorted to ground, a positive pulse is generated at the emitter of Q10, and Q10 is turned off aborting the sweep.

MANUAL Sweep Control

Manual control of the sweep is obtained with the TIME/DIV switch A2A1S3 in MAN position. A ground is applied to the base of Q38 and Q37 by the ST7 line from A2A1S3 in all sweep modes except manual; the ground holds Q38 and Q37 off. With A2A1S3 in MAN position, Q38 and Q37 are turned on. Q37 turns Q10 on and keeps it on. CR5 is on and the feedback loop to the timing capacitor is closed. Turning the MANUAL SWEEP control A2A1R4 changes the voltage at the collector of Q38 which changes the input current at U1 pin 2. Since the feedback current through R29 is constant, any change in manual sweep current must be compensated by a change in the current through R24, thereby varying the ramp output voltage.

Current Source

Current for the generation of the sweep is provided by the current source circuit. The temperature dependent power supply provides a nominal +10V; Q6 is the temperature sensing element (diode). The following switches control current to operational amplifier U2A pin 2: RESOLUTION BW switch A2A1S5, FREQ SPAN/DIV switch A2A1S6, VIDEO FILTER potentiometer A2R5, and TIME/DIV switch A2A1S3. In the AUTO sweep time mode, the sweep time is controlled by the RESOLUTION BW, FREQ SPAN/DIV, and VIDEO FILTER which set the currents to U2A. These currents are summed by U2A to produce a voltage proportional to the log of the sweep time. Q4 is the current driver and converts voltage variations into current variations proportional to sweep time. The current is applied to the timing capacitors C3 and C4, in the buffer amplifier circuit.

Q7 provides temperature compensation for Q4. Q8 is a constant-current regulator for Q7. In AUTO, the sweep time is limited to 1 ms and longer because current is limited to 1 mA by Q5/R15.

In the calibrated sweep time/division mode, the gate of Q52 is grounded. This turns Q52 off and disconnects the currents proportional to RESOLUTION BW, FREQ SPAN/DIV, and VIDEO FILTER. Calibrated sweep times are now produced by the currents fed to U2A through R40 through R44. Those resistors are grounded in various combinations by SWEEP TIME/DIV switch A2A1S3 resistor network. (See A2 Schematic.)

XTAL Resolution Bandwidth Control

When a XTAL bandwidth is selected (30 kHz, 10 kHz, 3 kHz, 1 kHz), control line BW5 is released from +15V on the front panel and is pulled to $-0.5V$ by Q13. This has four effects.

1. On the Bandwidth Filter boards CR2 and CR13 are turned off and Q3, Q6, CR8 and CR15 are turned on, allowing the XTAL filters to operate.
2. Q21 is turned off allowing BW7 to be pulled up to more than +10V by CR18 and R82. This turns off the LC filter sections on the Bandwidth Filter boards.
3. Q14 is turned off allowing the voltage on BW6 to be controlled by the current through A8Q19.
4. Q22 is turned off having an effect on sweep time which is discussed in detail later.

The current through Q19 is a function of the states (off or on) of Q15, Q17, Q42, the values of factory select resistors R74, R76, and R78, and the setting of R72 XTL (3 kHz adjustment). The off/on states of Q15, Q17, and Q42 are controlled by BW1, BW2, and BW3 which are controlled by the front panel RESOLUTION BW switch and are at either +15V or some negative voltage. The amount of current through Q19 controls the bandwidths of the XTAL filter sections on the Bandwidth Filter boards.

LC Resolution Bandwidth Control

When an LC bandwidth is selected, (3 MHz, 1 MHz, 300 kHz, 100 kHz), control line BW5 is pulled to +15V at the front panel. This has four effects.

1. On the Bandwidth Filter boards: Q3, Q6, CR8, and CR15 are turned off and CR2 and CR13 are turned on, thus blocking any signal from passing through the XTAL filter sections.
2. Q14 is turned on, pulling BW6 to $-4V$, which further defeats any possible action of the XTAL filter sections.
3. Q21 is turned on, allowing the voltage on BW7 to be controlled by the current through Q20.

The current through Q20 is a function of the states (off or on) of Q23, Q44, Q49, the values of factory select resistors R89, R92, and R95, and the setting of R85 LC (1 MHz adjustment). The off/on states of Q23, Q44, Q49 are controlled by BW2, BW3, and BW4 which are controlled by the front panel bandwidth switch and are either at +15V or some negative voltage. The amount of current through Q20 controls the bandwidths of the LC filter sections on the Bandwidth Filter boards.

4. Q22 is turned on having an effect on AUTO sweep time which is discussed later.

Video Filter

The video filter is composed of front panel control A2R6, switch A2S2, and 8 capacitors on Sweep Generator A8. The amount of filtering is controlled by the Resolution Bandwidth setting through Q16, Q18, Q43, Q41, Q46, Q24, and Q45. These transistors switch in and out various combinations of filter capacitors to provide more video filtering when the resolution bandwidth is decreased. In LC mode, BW6 is low holding Q15, Q17, Q42, Q41 off and keeping C19, C20, C21 and C22 out of the circuit.

Switch A2S2 applies maximum video filtering for noise measure mode by switching in C26 through Q47.

Sweep Attenuator

The sweep attenuator circuit changes the amplitude of the sweep voltage applied to the Frequency Control A7 as a function of the FREQ SPAN/DIV selected. The attenuator attenuates the -5V to +5V ramp routed through XA8 pin 39 in a divide by 1, 2, 5, and 10 sequence from a divide-by-1 to a divide-by-200. The circuit also generates an auto-sweep control current used to control the AUTO sweep time circuit as a function of the frequency span.

The sweep attenuator has two voltage dividers buffered by the unity gain voltage follower U3. The divider at the input of U3 provides either a divide-by-two or a divide-by-five; the divider at the output of the U3 provides a divide-by-one, a divide-by-ten, and a divide-by-one hundred.

Assuming that FS3 (divide-by-two) is selected, +15V turns on Q31 and Q32 grounds a 10K ohm resistor R113. The -5V to +5V ramp is divided across the input resistor R101 (10K ohms) and R113 (10K ohms). The ramp is now divided in half and applied to sweep buffer U3 pin 3. The dividers at the output of U3 (controlled by FS4 and FS5) have reversed control logic; they are normally connected to +15V by A2A1S5 and open when selected. Q50 is a gate to drive Q30. When FS4 and FS5 are connected to +15V, Q50 is off and Q30 is on, connecting the divide-by-one divider at the output of U3. If either FS4 or FS5 is open, Q30 is off and Q28 or Q26 is on, providing either a divide-by-10 or divide-by-100. AUTO sweep control current is applied to Q52 as a function of frequency span by Q35, Q31, Q33, Q27, and Q25 and the appropriate resistors. For narrow spans (1 MHz/DIV or less), when the YIG FM coil is swept, FS6 is connected to +15V by A2A1S5. Q29 is on and the additional current in the AUTO sweep control is used to reduce the sweep time.

+ V Sweep Offset

Normally, START – CENTER switch A2A1S7 is in the CENTER position. The +15V back biases Q54 and holds it off. Switching to START allows Q54 to conduct and adds 0.5 mA of current through R67 to offset the sweep ramp. When START frequency is used, the ramp excursion is from 0V to a positive voltage.

TABLE 7-8. A8 REPLACEMENT PARTS (2215A & BELOW)

Reference Designation	HP Part Number	C D	Qty	Description	Mfr Code	Mfr Part Number
A7R61	0757-0401	0		RESISTOR 100 1% .125W F TC=0+-100	24546	C4-1/8-T0-101-F
A7R62	0757-0416	7		RESISTOR 511 1% .125W F TC=0+-100	24546	C4-1/8-T0-511R-F
A7R63	0757-0199	3		RESISTOR 21.5K 1% .125W F TC=0+-100	24546	C4-1/8-T0-2152-F
A7R64	0698-3450	9	4	RESISTOR 42.2K 1% .125W F TC=0+-100	24546	C4-1/8-T0-4222-F
A7R65	0757-0441	8	1	RESISTOR 8.25K 1% .125W F TC=0+-100	24546	C4-1/8-T0-8251-F
A7R66	0811-3247	4	1	RESISTOR 150 1% 7.5W PW TC=0+-20	28480	0811-3247
A7R67	0683-1065	7	2	RESISTOR 10M 5% .25W CC TC=-900/+1100	01121	CB1065
A7R68	0698-3156	2		RESISTOR 14.7K 1% .125W F TC=0+-100	24546	C4-1/8-T0-1472-F
A7R69	0757-0199	3		RESISTOR 21.5K 1% .125W F TC=0+-100	24546	C4-1/8-T0-2152-F
A7R70	0757-0401	0		RESISTOR 100 1% .125W F TC=0+-100	24546	C4-1/8-T0-101-F
A7R71	0811-3246	3	1	RESISTOR 110 1% 7.5W PW TC=0+-20	28480	0811-3246
A7R72	2100-3094	4	1	RESISTOR-TRM 100K 10% C SIDE-ADJ 17-TRN	02111	43P104
A7R73	0757-0462	3	1	RESISTOR 75K 1% .125W F TC=0+-100	24546	C4-1/8-T0-7502-F
A7R74	0757-0459	8	1	RESISTOR 56.2K 1% .125W F TC=0+-100	24546	C4-1/8-T0-5622-F
A7R75	0698-3428	1	1	RESISTOR 14.7 1% .125W F TC=0+-100	03888	PME55-1/8-T0-14R7-F
A7R76	0757-0199	3		RESISTOR 21.5K 1% .125W F TC=0+-100	24546	C4-1/8-T0-2152-F
A7R77	0698-3132	4	2	RESISTOR 261 1% .125W F TC=0+-100	24546	C4-1/8-T0-2610-F
A7R78	0683-1065	7		RESISTOR 10M 5% .25W CC TC=-900/+1100	01121	CB1065
A7R79	0757-0422	5	1	RESISTOR 909 1% .125W F TC=0+-100	24546	C4-1/8-T0-909R-F
A7TP1 THRU A7TP19**	1251-0600	0	60	CONNECTOR-SGL CONT PIN 1.14-MM-BSC-SZ SQ	28480	1251-0600
A7U1	1826-0261	8	2	IC OP AMP LOW-NOISE TO-99 PKG	28480	1826-0261
A7U2 THRU A7U4	1826-0229	8	3	IC OP AMP LOW-DRIFFT TO-99 PKG	06665	OP-05CJ
A7U5	1858-0832	8	2	TRANSISTOR ARRAY 14-PIN PLSTC DIP	31585	CA3144E
A7U6	1826-0892	3	5	IC OP AMP GP DUAL TO-99 PKG	28480	1826-0892
A7U81	1902-0033	4	3	DIODE-ZNR 1N823 6.2V 5Z DO-7 PD=.4W	24046	1N823
A7U82	1902-0680	7	1	DIODE-ZNR 1N827 6.2V 5Z DO-7 PD=.4W	24046	1N827
A7U83	1902-0202	9	2	DIODE-ZNR 15V 5Z PD=1W IR=50A	28480	1902-0202
A8	08558-60123	9	1	SWEEP GENERATOR	28480	08558-60123
ABC1	0180-0197	8		CAPACITOR-FXD 2.2UF+-10% 20VDC TA	56289	150D225X9020A2
ABC2	0160-3456	5	12	CAPACITOR-FXD 100PF +-10% 1KVDC CER	28480	0160-3456
ABC3	0160-3462	2	1	CAPACITOR-FXD 1UF +-5% 50VDC MET-POLY C	28480	0160-3462
ABC4	0180-3009	5	1	CAPACITOR-FXD 982PF +-1% 100VDC MICA	56289	0160-3009
ABC5	0180-0197	8		CAPACITOR-FXD 2.2UF+-10% 20VDC TA	56289	150D225X9020A2
ABC6	0160-3094	8		CAPACITOR-FXD .1UF +-10% 100VDC CER	28480	0160-3094
ABC7	0160-3456	8		CAPACITOR-FXD 1000PF +-10% 1KVDC CER	28480	0160-3456
ABC8	0160-3466	9		CAPACITOR-FXD 100PF +-10% 1KVDC CER	28480	0160-3466
ABC9	0160-2257	3	1	CAPACITOR-FXD 10PF +-5% 500VDC CER 0+-60	28480	0160-2257
ABC10	0160-2150	5	1	CAPACITOR-FXD 33PF +-5% 300VDC MICA	28480	0160-2150
ABC11	0180-0197	8		CAPACITOR-FXD 2.2UF+-10% 20VDC TA	56289	150D225X9020A2
ABC12	0140-0192	9	1	CAPACITOR-FXD 68PF +-5% 300VDC MICA	72136	PM15580J0300MV1CR
ABC13	0180-0197	8		CAPACITOR-FXD 2.2UF+-10% 20VDC TA	56289	150D225X9020A2
ABC14	0160-4297	5	2	CAPACITOR-FXD .022UF +-20% 100VDC CER	56289	C023F101H225Z522-CDH
ABC15	0160-3456	6		CAPACITOR-FXD 1000PF +-10% 1KVDC CER	28480	0160-3456
ABC16	0160-3094	8		CAPACITOR-FXD .1UF +-10% 100VDC CER	28480	0160-3094
ABC17	0160-3449	7	1	CAPACITOR-FXD 2000PF +-10% 250VDC CER	28480	0160-3449
ABC18	0160-4297	5		CAPACITOR-FXD .022UF +-20% 100VDC CER	56289	C023F101H225Z522-CDH
ABC19	0180-2205	3	1	CAPACITOR-FXD .33UF+-10% 35VDC TA	56289	150D354X9035A2
ABC20	0180-1743	2	1	CAPACITOR-FXD .1UF+-10% 35VDC TA	56289	150D104X9035A2
ABC21	0160-0163	6	1	CAPACITOR-FXD .033UF +-10% 200VDC POLYE	28480	0160-0163
ABC22	0160-2055	9		CAPACITOR-FXD .01UF +-20% 100VDC CER	28480	0160-2055
ABC23	0160-0155	6	1	CAPACITOR-FXD 3300PF +-10% 200VDC POLYE	28480	0160-0155
ABC24	0160-0153	4	1	CAPACITOR-FXD 1000PF +-10% 200VDC POLYE	28480	0160-0153
ABC25	0160-0134	1	1	CAPACITOR-FXD 220PF +-5% 300VDC MICA	28480	0160-0134
ABC26	0180-0197	8		CAPACITOR-FXD 2.2UF+-10% 20VDC TA	56289	150D225X9020A2
ABC27	0170-0066	9	1	CAPACITOR-FXD .027UF +-10% 200VDC POLYE	28480	0170-0066
ABCR1	1901-0040	1		DIODE-SWITCHING 30V 50MA 2NS DO-35	28480	1901-0040
ABCR2	1901-0040	1		DIODE-SWITCHING 30V 50MA 2NS DO-35	28480	1901-0040
ABCR3	1901-0040	1		DIODE-SWITCHING 30V 50MA 2NS DO-35	28480	1901-0040
ABCR4	1901-0040	1		DIODE-SWITCHING 30V 50MA 2NS DO-35	28480	1901-0040
ABCR5	1901-0376	6	2	DIODE-GEN PRP 35V 50MA DO-35	28480	1901-0376
ABCR6	1901-0040	1		DIODE-SWITCHING 30V 50MA 2NS DO-35	28480	1901-0040
ABCR7	1901-0040	1		DIODE-SWITCHING 30V 50MA 2NS DO-35	28480	1901-0040
ABCR8	1901-0040	1		DIODE-SWITCHING 30V 50MA 2NS DO-35	28480	1901-0040
ABCR9	1901-0040	1		DIODE-SWITCHING 30V 50MA 2NS DO-35	28480	1901-0040
ABCR10	1901-0040	1		DIODE-SWITCHING 30V 50MA 2NS DO-35	28480	1901-0040
ABCR11	1901-0040	1		DIODE-SWITCHING 30V 50MA 2NS DO-35	28480	1901-0040
ABCR12	1901-0050	3		DIODE-SWITCHING 80V 200MA 2NS DO-35	28480	1901-0050
ABCR13	1901-0050	3		DIODE-SWITCHING 80V 200MA 2NS DO-35	28480	1901-0050
ABCR14	1901-0050	3		DIODE-SWITCHING 80V 200MA 2NS DO-35	28480	1901-0050
ABCR15	1901-0050	3		DIODE-SWITCHING 80V 200MA 2NS DO-35	28480	1901-0050

See introduction to this section for ordering information
 *Indicates factory selected value

**A7TP11 IS GND; A7TP12 NOT ASSIGNED.

TABLE 78. A8REPLACEABLE PARTS (2215A & BELOW)

Reference Designation	HP Part Number	C	Qty	Description	Mfr Code	Mfr Part Number
A8CR16	1901-0050	3		DIODE-SWITCHING 80V 200MA 2NS DO-35	28480	1901-0050
A8CR17	1901-0050	3		DIODE-SWITCHING 80V 200MA 2NS DO-35	28480	1901-0050
A8CR18	1901-0050	3		DIODE-SWITCHING 80V 200MA 2NS DO-35	28480	1901-0050
A8CR19	1901-0050	3		DIODE-SWITCHING 80V 200MA 2NS DO-35	28480	1901-0050
A8CR20	1901-0050	3		DIODE-SWITCHING 80V 200MA 2NS DO-35	28480	1901-0050
A8CR21	1901-0050	3		DIODE-SWITCHING 80V 200MA 2NS DO-35	28480	1901-0050
A8CR22	1901-0050	3		DIODE-SWITCHING 80V 200MA 2NS DO-35	28480	1901-0050
A8CR23	1901-0050	3		DIODE-SWITCHING 80V 200MA 2NS DO-35	28480	1901-0050
A8CR24	1901-0050	3		DIODE-SWITCHING 80V 200MA 2NS DO-35	28480	1901-0050
A8CR25	1901-0050	3		DIODE-SWITCHING 80V 200MA 2NS DO-35	28480	1901-0050
A8MP1	1205-0202	1	1	THERMAL LINK DUAL TO-18-CS	28480	1205-0202
A8MP2	0380-0198	1	1	STANDOFF-RVT-0N .312-IN-LG 6-32THTD	00000	ORDER BY DESCRIPTION
A8MP3	2360-0055	1	1	SCREW-MACH 6-32 .188-IN-LG B0G-HD-SLT	00000	ORDER BY DESCRIPTION
A8Q1	1854-0071	7	16	TRANSISTOR NPN SI PD=300MHZ FT=200MHZ	28480	1854-0071
A8Q2	1855-0082	2	7	TRANSISTOR J-FET P-CHAN D-MODE SI	28480	1855-0082
A8Q3	1855-0082	2		TRANSISTOR J-FET P-CHAN D-MODE SI	28480	1855-0082
A8Q4	1853-0007	7	5	TRANSISTOR PNP 2N3251 SI TO-18 PD=360MHZ	04713	2N3251
A8Q5	1853-0020	4		TRANSISTOR PNP SI PD=300MHZ FT=150MHZ	28480	1853-0020
A8Q6	1854-0071	7		TRANSISTOR NPN SI PD=300MHZ FT=200MHZ	28480	1854-0071
A8Q7	1853-0007	7		TRANSISTOR PNP 2N3251 SI TO-18 PD=360MHZ	04713	2N3251
A8Q8	1854-0071	7		TRANSISTOR NPN SI PD=300MHZ FT=200MHZ	28480	1854-0071
A8Q9	1854-0071	7		TRANSISTOR NPN SI PD=300MHZ FT=200MHZ	28480	1854-0071
A8Q10	1854-0404	0		TRANSISTOR NPN SI TO-18 PD=360MHZ	28480	1854-0404
A8Q11	1855-0417	7		TRANSISTOR J-FET N-CHAN D-MODE TO-18 SI	28480	1855-0417
A8Q12	1853-0020	4		TRANSISTOR PNP SI PD=300MHZ FT=150MHZ	28480	1853-0020
A8Q13	1854-0404	0		TRANSISTOR NPN SI TO-18 PD=360MHZ	28480	1854-0404
A8Q14	1854-0404	0		TRANSISTOR NPN SI TO-18 PD=360MHZ	28480	1854-0404
A8Q15	1854-0404	0		TRANSISTOR NPN SI TO-18 PD=360MHZ	28480	1854-0404
A8Q16	1854-0019	3	20	TRANSISTOR NPN SI TO-18 PD=360MHZ	28480	1854-0019
A8Q17	1854-0404	0		TRANSISTOR NPN SI TO-18 PD=360MHZ	28480	1854-0404
A8Q18	1854-0019	3		TRANSISTOR NPN SI TO-18 PD=360MHZ	28480	1854-0019
A8Q19	1854-0404	0		TRANSISTOR NPN SI TO-18 PD=360MHZ	28480	1854-0404
A8Q20	1854-0404	0		TRANSISTOR NPN SI TO-18 PD=360MHZ	28480	1854-0404
A8Q21	1854-0404	0		TRANSISTOR NPN SI TO-18 PD=360MHZ	28480	1854-0404
A8Q22	1854-0404	0		TRANSISTOR NPN SI TO-18 PD=360MHZ	28480	1854-0404
A8Q23	1854-0404	0		TRANSISTOR NPN SI TO-18 PD=360MHZ	28480	1854-0404
A8Q24	1854-0019	3		TRANSISTOR NPN SI TO-18 PD=360MHZ	28480	1854-0019
A8Q25	1855-0082	2		TRANSISTOR J-FET P-CHAN D-MODE SI	28480	1855-0082
A8Q26	1855-0082	2		TRANSISTOR J-FET P-CHAN D-MODE SI	28480	1855-0082
A8Q27	1855-0082	2		TRANSISTOR J-FET P-CHAN D-MODE SI	28480	1855-0082
A8Q28	1855-0082	2		TRANSISTOR J-FET P-CHAN D-MODE SI	28480	1855-0082
A8Q29	1855-0062	8		TRANSISTOR J-FET N-CHAN D-MODE SI	28480	1855-0062
A8Q30	1855-0082	2		TRANSISTOR J-FET P-CHAN D-MODE SI	28480	1855-0082
A8Q31	1854-0071	7		TRANSISTOR NPN SI PD=300MHZ FT=200MHZ	28480	1854-0071
A8Q32	1854-0071	7		TRANSISTOR NPN SI PD=300MHZ FT=200MHZ	28480	1854-0071
A8Q33	1854-0071	7		TRANSISTOR NPN SI PD=300MHZ FT=200MHZ	28480	1854-0071
A8Q34	1854-0071	7		TRANSISTOR NPN SI PD=300MHZ FT=200MHZ	28480	1854-0071
A8Q35	1854-0071	7		TRANSISTOR NPN SI PD=300MHZ FT=200MHZ	28480	1854-0071
A8Q36	1854-0071	7		TRANSISTOR NPN SI PD=300MHZ FT=200MHZ	28480	1854-0071
A8Q37	1853-0020	4		TRANSISTOR PNP SI PD=300MHZ FT=150MHZ	28480	1853-0020
A8Q38	1854-0071	7		TRANSISTOR NPN SI PD=300MHZ FT=200MHZ	28480	1854-0071
A8Q39	1854-0071	7		TRANSISTOR NPN SI PD=300MHZ FT=200MHZ	28480	1854-0071
A8Q40	1854-0071	7		TRANSISTOR NPN SI PD=300MHZ FT=200MHZ	28480	1854-0071
A8Q41	1854-0404	0		TRANSISTOR NPN SI TO-18 PD=360MHZ	28480	1854-0404
A8Q42	1854-0404	0		TRANSISTOR NPN SI TO-18 PD=360MHZ	28480	1854-0404
A8Q43	1854-0019	3		TRANSISTOR NPN SI TO-18 PD=360MHZ	28480	1854-0019
A8Q44	1854-0404	0		TRANSISTOR NPN SI TO-18 PD=360MHZ	28480	1854-0404
A8Q45	1854-0019	3		TRANSISTOR NPN SI TO-18 PD=360MHZ	28480	1854-0019
A8Q46	1854-0404	0		TRANSISTOR NPN SI TO-18 PD=360MHZ	28480	1854-0404
A8Q47	1854-0019	3		TRANSISTOR NPN SI TO-18 PD=360MHZ	28480	1854-0019
A8Q48	1854-0404	0		TRANSISTOR NPN SI TO-18 PD=360MHZ	28480	1854-0404
A8Q49	1854-0404	0		TRANSISTOR NPN SI TO-18 PD=360MHZ	28480	1854-0404
A8Q50	1853-0020	4		TRANSISTOR PNP SI TO-18 PD=360MHZ	28480	1853-0020
A8Q51	1854-0071	7		TRANSISTOR NPN SI PD=300MHZ FT=200MHZ	28480	1854-0071
A8Q52	1855-0417	7		TRANSISTOR J-FET N-CHAN D-MODE TO-18 SI	28480	1855-0417
A8Q53	1854-0071	7		TRANSISTOR NPN SI PD=300MHZ FT=200MHZ	28480	1854-0071
A8Q54	1853-0020	4		TRANSISTOR PNP SI PD=300MHZ FT=150MHZ	28480	1853-0020
A8Q55	1854-0071	7		TRANSISTOR NPN SI PD=300MHZ FT=200MHZ	28480	1854-0071
A8R1	0698-3450	9		RESISTOR 42.2K 1% .125W F TC=0+-100	24546	C4-1/8-T0-4222-F
A8R2	2100-3154	7	1	RESISTOR-TFRM 1K 10% C SIDE-ADJ 17-TRN	02111	430102
A8R3	0757-0279	0		RESISTOR 3.16K 1% .125W F TC=0+-100	24546	C4-1/8-T0-3161-F
A8R4	0757-0419	0	6	RESISTOR 681 1% .125W F TC=0+-100	24546	C4-1/8-T0-681R-F
A8R5	0757-0459	0		RESISTOR 56.2K 1% .125W F TC=0+-100	24546	C4-1/8-T0-5622-F
A8R6	0698-3152	8	2	RESISTOR 3.48K 1% .125W F TC=0+-100	24546	C4-1/8-T0-3481-F
A8R7	0757-0442	9		RESISTOR 10K 1% .125W F TC=0+-100	24546	C4-1/8-T0-1002-F
A8R8	0757-0442	9		RESISTOR 10K 1% .125W F TC=0+-100	24546	C4-1/8-T0-1002-F
A8R9	0757-0444	1		RESISTOR 12.1K 1% .125W F TC=0+-100	24546	C4-1/8-T0-1212-F
A8R10	2100-3109	2	1	RESISTOR-TFRM 2K 10% C SIDE-ADJ 17-TRN	02111	430202

See introduction to this section for ordering information
 *Indicates factory selected value

TABLE 7-8. A8 REPLACEABLE PARTS (2215A & BELOW)

Reference Designation	HP Part Number	C D	Qty	Description	Mfr Code	Mfr Part Number
ABR11	0698-3457	6		RESISTOR 316K 1% .125W F TC=0+-100	28480	0698-3457
ABR12	0698-3442	9	7	RESISTOR 237 1% .125W F TC=0+-100	24546	CA-1/8-T0-237R-F
ABR13	2100-3852	4	3	RESISTOR-TRMR 50 10% C SIDE-ADJ 17-TRN	02111	43P500
ABR14	0698-3446	3		RESISTOR 383 1% .125W F TC=0+-100	24546	CA-1/8-T0-383R-F
ABR15	0757-0424	7		RESISTOR 1.1K 1% .125W F TC=0+-100	24546	CA-1/8-T0-1101-F
ABR16	0698-7412	1	3	RESISTOR 13.3K .25% .125W F TC=0+-100	19701	MF4C1/8-T0-1332-C
ABR17	0757-0442	9		RESISTOR 10K 1% .125W F TC=0+-100	24546	CA-1/8-T0-1002-F
ABR18	0757-0458	7		RESISTOR 51.1K 1% .125W F TC=0+-100	24546	CA-1/8-T0-5112-F
ABR19	0757-0465	6		RESISTOR 100K 1% .125W F TC=0+-100	24546	CA-1/8-T0-1003-F
ABR20	0757-0465	6		RESISTOR 100K 1% .125W F TC=0+-100	24546	CA-1/8-T0-1003-F
ABR21	0757-0279	0		RESISTOR 3.16K 1% .125W F TC=0+-100	24546	CA-1/8-T0-3161-F
ABR22	0757-0280	3		RESISTOR 1K 1% .125W F TC=0+-100	24546	CA-1/8-T0-1001-F
ABR23	0698-3444	1	17	RESISTOR 316 1% .125W F TC=0+-100	24546	CA-1/8-T0-316R-F
ABR24	0698-7794	2	8	RESISTOR 10K .25% .125W F TC=0+-100	19701	MF4C1/8-T0-1002-C
ABR25	0698-8416	7	1	RESISTOR 44K .25% .125W F TC=0+-50	19701	MF4C1/8-T2-4402-C
ABR26	0698-7794	2		RESISTOR 10K .25% .125W F TC=0+-100	19701	MF4C1/8-T0-1002-C
ABR27	0683-3355	2	3	RESISTOR 3.3M 5% .25W FC TC=-900/+1100	01121	CR3355
ABR28	0683-3355	2	2	RESISTOR 3.3M 5% .25W FC TC=-900/+1100	01121	CR3355
ABR29	0698-7794	2		RESISTOR 10K .25% .125W F TC=0+-100	19701	MF4C1/8-T0-1002-C
ABR30*	0698-7798	6	1	RESISTOR 5.25K .25% .125W F TC=0+-100	19701	MF4C1/8-T0-5251-C
ABR31	0757-0442	9		RESISTOR 10K 1% .125W F TC=0+-100	24546	CA-1/8-T0-1002-F
ABR32	0698-3160	8		RESISTOR 31.6K 1% .125W F TC=0+-100	24546	CA-1/8-T0-3162-F
ABR33	0698-3260	9		RESISTOR 464K 1% .125W F TC=0+-100	28480	0698-3260
ABR34	0698-3160	8		RESISTOR 31.6K 1% .125W F TC=0+-100	24546	CA-1/8-T0-3162-F
ABR35*	0757-0400	9	2	RESISTOR 90.9 1% .125W F TC=0+-100	24546	CA-1/8-T0-909F-F
ABR36	0757-0401	0		RESISTOR 100 1% .125W F TC=0+-100	24546	CA-1/8-T0-101-F
ABR37	0683-6845	1	1	RESISTOR 680K 5% .25W FC TC=-800/+900	01121	CR6845
ABR38	0698-3457	6		RESISTOR 316K 1% .125W F TC=0+-100	28480	0698-3457
ABR39	0757-0442	9		RESISTOR 10K 1% .125W F TC=0+-100	24546	CA-1/8-T0-1002-F
ABR40	0698-3451	0	2	RESISTOR 133K 1% .125W F TC=0+-100	24546	CA-1/8-T0-1333-F
ABR41	0757-0459	8		RESISTOR 56.2K 1% .125W F TC=0+-100	24546	CA-1/8-T0-5622-F
ABR42	0698-7421	2	3	RESISTOR 40K .25% .125W F TC=0+-100	19701	MF4C1/8-T0-4002-C
ABR43	0698-3194	8	4	RESISTOR 20K .25% .125W F TC=0+-50	0388B	PH855-1/8-T2-2002-C
ABR44	0698-7794	2		RESISTOR 10K .25% .125W F TC=0+-100	19701	MF4C1/8-T0-1002-C
ABR45	0698-3156	2		RESISTOR 14.7K 1% .125W F TC=0+-100	24546	CA-1/8-T0-1472-F
ABR46	0757-0199	3		RESISTOR 21.5K 1% .125W F TC=0+-100	24546	CA-1/8-T0-2152-F
ABR47	0757-0346	2		RESISTOR 10 1% .125W F TC=0+-100	24546	CA-1/8-T0-10R0-F
ABR48	0757-0465	6		RESISTOR 100K 1% .125W F TC=0+-100	24546	CA-1/8-T0-1003-F
ABR49	0757-0464	5	3	RESISTOR 90.9K 1% .125W F TC=0+-100	24546	CA-1/8-T0-9092-F
ABR50	0757-0442	9		RESISTOR 10K 1% .125W F TC=0+-100	24546	CA-1/8-T0-1002-F
ABR51	0757-0279	0		RESISTOR 3.16K 1% .125W F TC=0+-100	24546	CA-1/8-T0-3161-F
ABR52	0757-0439	4	4	RESISTOR 6.81K 1% .125W F TC=0+-100	24546	CA-1/8-T0-6811-F
ABR53	0757-0460	1		RESISTOR 61.9K 1% .125W F TC=0+-100	24546	CA-1/8-T0-6192-F
ABR54	0757-0442	9		RESISTOR 10K 1% .125W F TC=0+-100	24546	CA-1/8-T0-1002-F
ABR55	0757-0442	9		RESISTOR 10K 1% .125W F TC=0+-100	24546	CA-1/8-T0-1002-F
ABR56	0757-0465	6		RESISTOR 100K 1% .125W F TC=0+-100	24546	CA-1/8-T0-1003-F
ABR57	0757-0439	4		RESISTOR 6.81K 1% .125W F TC=0+-100	24546	CA-1/8-T0-6811-F
ABR58	0757-0465	6		RESISTOR 100K 1% .125W F TC=0+-100	24546	CA-1/8-T0-1003-F
ABR59	0757-0279	0		RESISTOR 3.16K 1% .125W F TC=0+-100	24546	CA-1/8-T0-3161-F
ABR60	0698-3160	8		RESISTOR 31.6K 1% .125W F TC=0+-100	24546	CA-1/8-T0-3162-F
ABR61	0757-0465	6		RESISTOR 100K 1% .125W F TC=0+-100	24546	CA-1/8-T0-1003-F
ABR62	0757-0465	6		RESISTOR 100K 1% .125W F TC=0+-100	24546	CA-1/8-T0-1003-F
ABR63	0757-0346	2		RESISTOR 10 1% .125W F TC=0+-100	24546	CA-1/8-T0-10R0-F
ABR64	0757-0199	3		RESISTOR 21.5K 1% .125W F TC=0+-100	24546	CA-1/8-T0-2152-F
ABR65	0757-0199	3		RESISTOR 21.5K 1% .125W F TC=0+-100	24546	CA-1/8-T0-2152-F
ABR66	0757-0199	3		RESISTOR 21.5K 1% .125W F TC=0+-100	24546	CA-1/8-T0-2152-F
ABR67	0757-0199	3		RESISTOR 21.5K 1% .125W F TC=0+-100	24546	CA-1/8-T0-2152-F
ABR68	0698-7412	1	4	RESISTOR 13.3K .25% .125W F TC=0+-100	19701	MF4C1/8-T0-1332-C
ABR69	0757-1094	9		RESISTOR 1.47K 1% .125W F TC=0+-100	24546	CA-1/8-T0-1471-F
ABR70	0757-0199	3		RESISTOR 21.5K 1% .125W F TC=0+-100	24546	CA-1/8-T0-2152-F
ABR71	0757-0199	3		RESISTOR 21.5K 1% .125W F TC=0+-100	24546	CA-1/8-T0-2152-F
ABR72	2100-2850	3	2	RESISTOR-TRMR 10K 10% MM SIDE-ADJ 20-TRN	02660	3810P-103
ABR73	0757-0199	3		RESISTOR 21.5K 1% .125W F TC=0+-100	24546	CA-1/8-T0-2152-F
ABR74*	0698-3151	7	8	RESISTOR 2.87K 1% .125W F TC=0+-100	24546	CA-1/8-T0-2871-F
ABR75	0757-0199	3		RESISTOR 21.5K 1% .125W F TC=0+-100	24546	CA-1/8-T0-2152-F
ABR76*	0757-0442	9	47	RESISTOR 10K 1% .125W F TC=0+-100	24546	CA-1/8-T0-1002-F
ABR77	0757-0199	3		RESISTOR 21.5K 1% .125W F TC=0+-100	24546	CA-1/8-T0-2152-F
ABR78*	0757-0458	7	6	RESISTOR 51.1K 1% .125W F TC=0+-100	24546	CA-1/8-T0-5112-F
ABR79	0757-0199	3		RESISTOR 21.5K 1% .125W F TC=0+-100	24546	CA-1/8-T0-2152-F
ABR80	0757-0199	3		RESISTOR 21.5K 1% .125W F TC=0+-100	24546	CA-1/8-T0-2152-F
ABR81	0757-0199	3		RESISTOR 21.5K 1% .125W F TC=0+-100	24546	CA-1/8-T0-2152-F
ABR82	0698-0185	9	2	RESISTOR 2.61K 1% .125W F TC=0+-100	24546	CA-1/8-T0-2611-F
ABR83	0698-3260	9		RESISTOR 464K 1% .125W F TC=0+-100	28480	0698-3260
ABR84	0757-0444	1		RESISTOR 12.1K 1% .125W F TC=0+-100	24546	CA-1/8-T0-1212-F
ABR85	2100-2850	8		RESISTOR-TRMR 10K 10% MM SIDE-ADJ 20-TRN	02660	3810P-103

See introduction to this section for ordering information
 *Indicates factory selected value

TABLE 7-8. A8 REPLACEMENT PARTS (215A & BELOW)

Reference Designation	HP Part Number	C	Qty	Description	Mfr Code	Mfr Part Number
A8R86	0698-7794	2		RESISTOR 10K .25% .125W F TC=0+-100	19701	MFAC1/8-T0-1002-C
A8R87	0757-0199	3		RESISTOR 21.5K 1% .125W F TC=0+-100	24546	CA-1/8-T0-2152-F
A8R88	0757-0199	3		RESISTOR 21.5K 1% .125W F TC=0+-100	24546	CA-1/8-T0-2152-F
A8R89*	0757-0460	1	3	RESISTOR 401.94K 1% .125W F TC=0+-100	24546	CA-1/8-T0-6192-F
A8R90	0698-7421	1		RESISTOR 40K .25% .125W F TC=0+-100	19701	MFAC1/8-T0-4002-C
A8R91	0757-0199	3		RESISTOR 21.5K 1% .125W F TC=0+-100	24546	CA-1/8-T0-2152-F
A8R92*	0757-0289	2	7	RESISTOR 13.3K 1% .125W F TC=0+-100	19701	MFAC1/8-T0-1332-C
A8R93	0698-3194	8		RESISTOR 20K .25% .125W F TC=0+-100	03088	PME55-1/8-T2-2002-C
A8R94	0757-0199	3		RESISTOR 21.5K 1% .125W F TC=0+-100	24546	CA-1/8-T0-2152-F
A8R95*	0698-3153	9	10	RESISTOR 3.83K 1% .125W F TC=0+-100	24546	CA-1/8-T0-3831-F
A8R96	0698-7412	1		RESISTOR 13.3K .25% .125W F TC=0+-100	19701	MFAC1/8-T0-1332-C
A8R97	0757-0199	3		RESISTOR 21.5K 1% .125W F TC=0+-100	24546	CA-1/8-T0-2152-F
A8R98	0757-0442	9		RESISTOR 10K 1% .125W F TC=0+-100	24546	CA-1/8-T0-1002-F
A8R99	0757-0199	3		RESISTOR 21.5K 1% .125W F TC=0+-100	24546	CA-1/8-T0-2152-F
A8R100	0757-0465	6		RESISTOR 100K 1% .125W F TC=0+-100	24546	CA-1/8-T0-1003-F
A8R101	0698-7794	2		RESISTOR 10K .25% .125W F TC=0+-100	19701	MFAC1/8-T0-1002-C
A8R102	0757-0459	8		RESISTOR 56.2K 1% .125W F TC=0+-100	24546	CA-1/8-T0-5622-F
A8R103	0757-0442	9		RESISTOR 10K 1% .125W F TC=0+-100	24546	CA-1/8-T0-1002-F
A8R104	0698-3154	0		RESISTOR 4.22K 1% .125W F TC=0+-100	24546	CA-1/8-T0-4221-F
A8R105*	0698-3457	6	5	RESISTOR 316K 1% .125W F TC=0+-100	28480	0698-3457
A8R106	0757-0440	7	10	RESISTOR 7.5K 1% .125W F TC=0+-100	24546	CA-1/8-T0-7501-F
A8R107	0757-0442	9		RESISTOR 10K 1% .125W F TC=0+-100	24546	CA-1/8-T0-1002-F
A8R108	0757-0442	9		RESISTOR 10K 1% .125W F TC=0+-100	24546	CA-1/8-T0-1002-F
A8R109	0757-0442	9		RESISTOR 10K 1% .125W F TC=0+-100	24546	CA-1/8-T0-1002-F
A8R110	0698-3451	0		RESISTOR 133K 1% .125W F TC=0+-100	24546	CA-1/8-T0-1333-F
A8R111	0757-0442	9		RESISTOR 10K 1% .125W F TC=0+-100	24546	CA-1/8-T0-1002-F
A8R112	0757-0442	9		RESISTOR 10K 1% .125W F TC=0+-100	24546	CA-1/8-T0-1002-F
A8R113	0698-7794	2		RESISTOR 10K .25% .125W F TC=0+-100	19701	MFAC1/8-T0-1002-C
A8R114	0757-0459	8		RESISTOR 56.2K 1% .125W F TC=0+-100	24546	CA-1/8-T0-5622-F
A8R115	0757-0442	9		RESISTOR 10K 1% .125W F TC=0+-100	24546	CA-1/8-T0-1002-F
A8R116	0757-0442	9		RESISTOR 10K 1% .125W F TC=0+-100	24546	CA-1/8-T0-1002-F
A8R117	0698-3238	1	1	RESISTOR 2.5K .25% .125W F TC=0+-50	28480	0698-3238
A8R118	0757-0442	6		RESISTOR 10K 1% .125W F TC=0+-100	24546	CA-1/8-T0-1002-F
A8R119	0698-7794	2		RESISTOR 10K .25% .125W F TC=0+-100	19701	MFAC1/8-T0-1002-C
A8R120	0698-7086	5	1	RESISTOR 1.02K .25% .125W F TC=0+-100	28480	0698-7086
A8R121	0698-8322	4	1	RESISTOR 111 .25% .125W F TC=0+-100	19701	MFAC1/8-T0-1118-C
A8R122	0683-1053	3	3	RESISTOR 1M 5% .25W F TC=800/4900	01121	CR1055
A8R123	0683-1053	3		RESISTOR 1M 5% .25W F TC=800/4900	01121	CR1055
A8R124	0757-0465	6		RESISTOR 100K 1% .125W F TC=0+-100	24546	CA-1/8-T0-1003-F
A8R125*	0757-0461	2	1	RESISTOR 68.1K 1% .125W F TC=0+-100	24546	CA-1/8-T0-6812-F
A8R126	0757-0442	9		RESISTOR 10K 1% .125W F TC=0+-100	24546	CA-1/8-T0-1002-F
A8R127	0698-7421	2		RESISTOR 40K .25% .125W F TC=0+-100	19701	MFAC1/8-T0-4002-C
A8R128	0757-0442	9		RESISTOR 10K 1% .125W F TC=0+-100	24546	CA-1/8-T0-1002-F
A8R129	0698-3194	8		RESISTOR 20K .25% .125W F TC=0+-50	03988	PME55-1/8-T2-2002-C
A8R130	0683-3355	2		RESISTOR 3.34M 5% .25W F TC=900/1100	01121	CR3355
A8R131	0757-0442	9		RESISTOR 10K 1% .125W F TC=0+-100	24546	CA-1/8-T0-1002-F
A8R132	0698-3194	8		RESISTOR 20K .25% .125W F TC=0+-50	03988	PME55-1/8-T2-2002-C
A8R133	0698-3194	8		RESISTOR 20K .25% .125W F TC=0+-50	03988	PME55-1/8-T2-2002-C
ABTP1 THRU		0				
ABTP9	1251-0600	0		CONNECTOR-SQL CONT PIN 1,14-MH-RSC-S7 S4	28480	1251-0600
ABU1	1820-0223	0	1	IC OP AMP GP TO-99 PKG	3LS95	CA301AT
ABU2	1826-0092	3		IC OP AMP GP DUAL TO-99 PKG	28480	1826-0092
ABU3	1826-0261	8		IC OP AMP LOW-NOISE TO-99 PKG	28480	1826-0261
ABUR1	1902-0025	4	2	DIODE-ZNR 10V 5% DO-35 PD=.4W TC=+,06Z	28480	1902-0025
ABUR2	1902-3139	7	1	DIODE-ZNR 8.25V 5% DO-35 PD=.4W TC=+,06Z	28480	1902-3139
ABUR3	1902-0049	2	1	DIODE-ZNR 6.19V 5% DO-35 PD=.4W TC=+,06Z	28480	1902-0049
A9	08558-60154 *	6	1	THIRD CONVERTER	28480	08558-60154
A9	08558-60155	7	1	THIRD CONVERTER, OPTION 001/002	28480	08558-60155
A9C1	0160-3878	6	12	CAPACITOR-FXD 1000PF +-20% 100VDC CER	28480	0160-3878
A9C2	0160-3878	6		CAPACITOR-FXD 1000PF +-20% 100VDC CER	28480	0160-3878
A9C3	0160-3878	6		CAPACITOR-FXD 1000PF +-20% 100VDC CER	28480	0160-3878
A9C4	0160-2249	3	1	CAPACITOR-FXD 4.7PF +-25PF 500VDC CER	28480	0160-2249
A9C5	0160-2264	2	1	CAPACITOR-FXD 20PF +-5Z 500VDC CER 0+-30	28480	0160-2264
A9C6	0160-3878	6		CAPACITOR-FXD 1000PF +-20% 100VDC CER	28480	0160-3878
A9C7	0160-3878	6		CAPACITOR-FXD 1000PF +-20% 100VDC CER	28480	0160-3878
A9C8	0160-3878	6		CAPACITOR-FXD 1000PF +-20% 100VDC CER	28480	0160-3878
A9C9	0160-3878	6		CAPACITOR-FXD 1000PF +-20% 100VDC CER	28480	0160-3878
A9C10	0160-2207	3	5	CAPACITOR-FXD 300PF +-5Z 300VDC MICA	28480	0160-2207
A9C11	0140-0195	2	2	CAPACITOR-FXD 130PF +-5Z 300VDC MICA	72136	DM1SF131J0300WV1CR
A9C12	0140-0198	5	1	CAPACITOR-FXD 200PF +-5Z 300VDC MICA	72136	DM1SF201J0300WV1CR
A9C13	0180-0197	8		CAPACITOR-FXD 2.2UF+-10% 20VDC TA	56289	1500225X920A2
A9C14	0180-0197	8		CAPACITOR-FXD 2.2UF+-10% 20VDC TA	56289	1500225X920A2
A9C15	0160-3878	6		CAPACITOR-FXD 1000PF +-20% 100VDC CER	28480	0160-3878

See introduction to this section for ordering information
*Indicates factory selected value

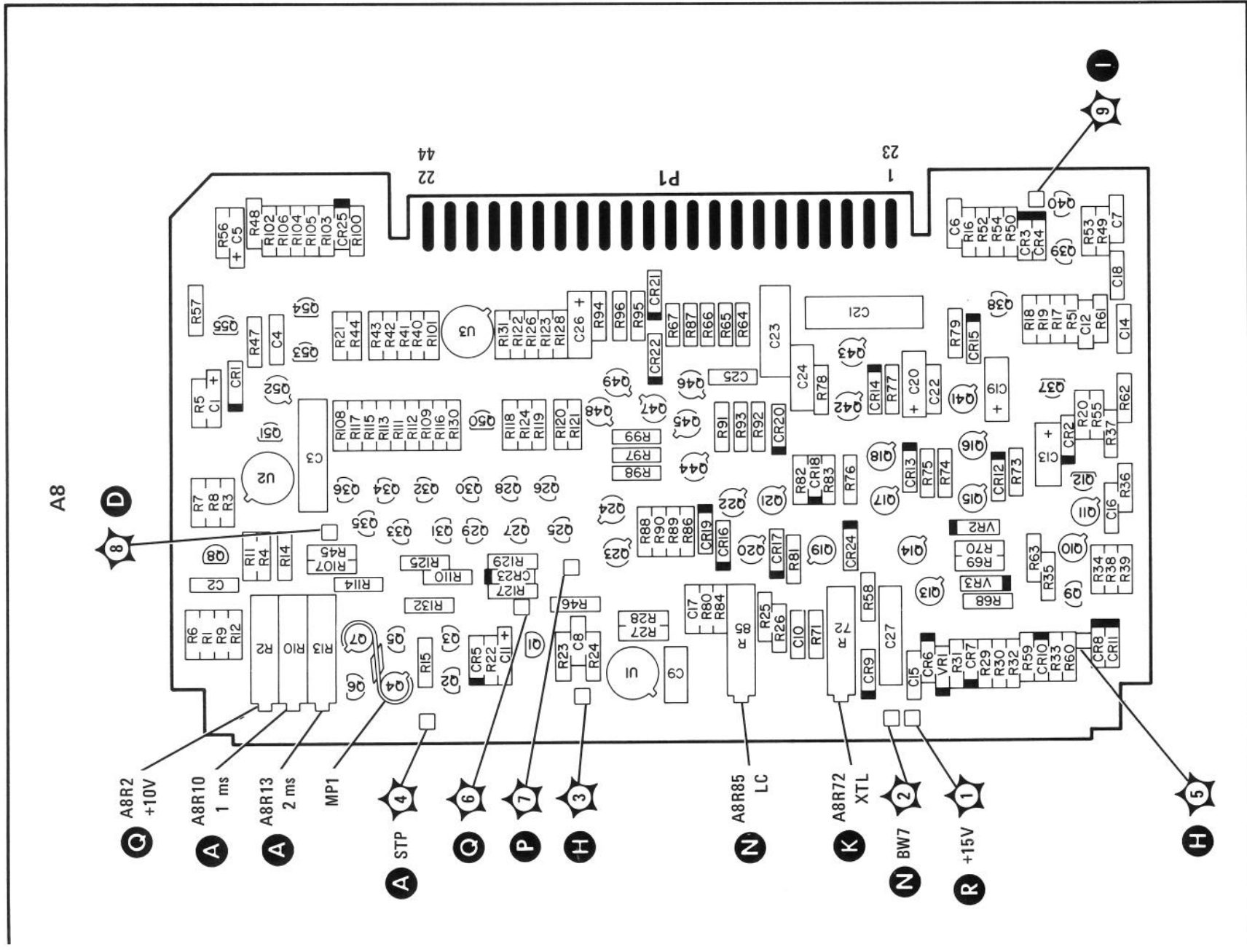

FIGURE 7-15. A8 SWEEP GENERATOR ASSEMBLY, COMPONENT AND TEST POINT LOCATIONS (2215A & BELOW)

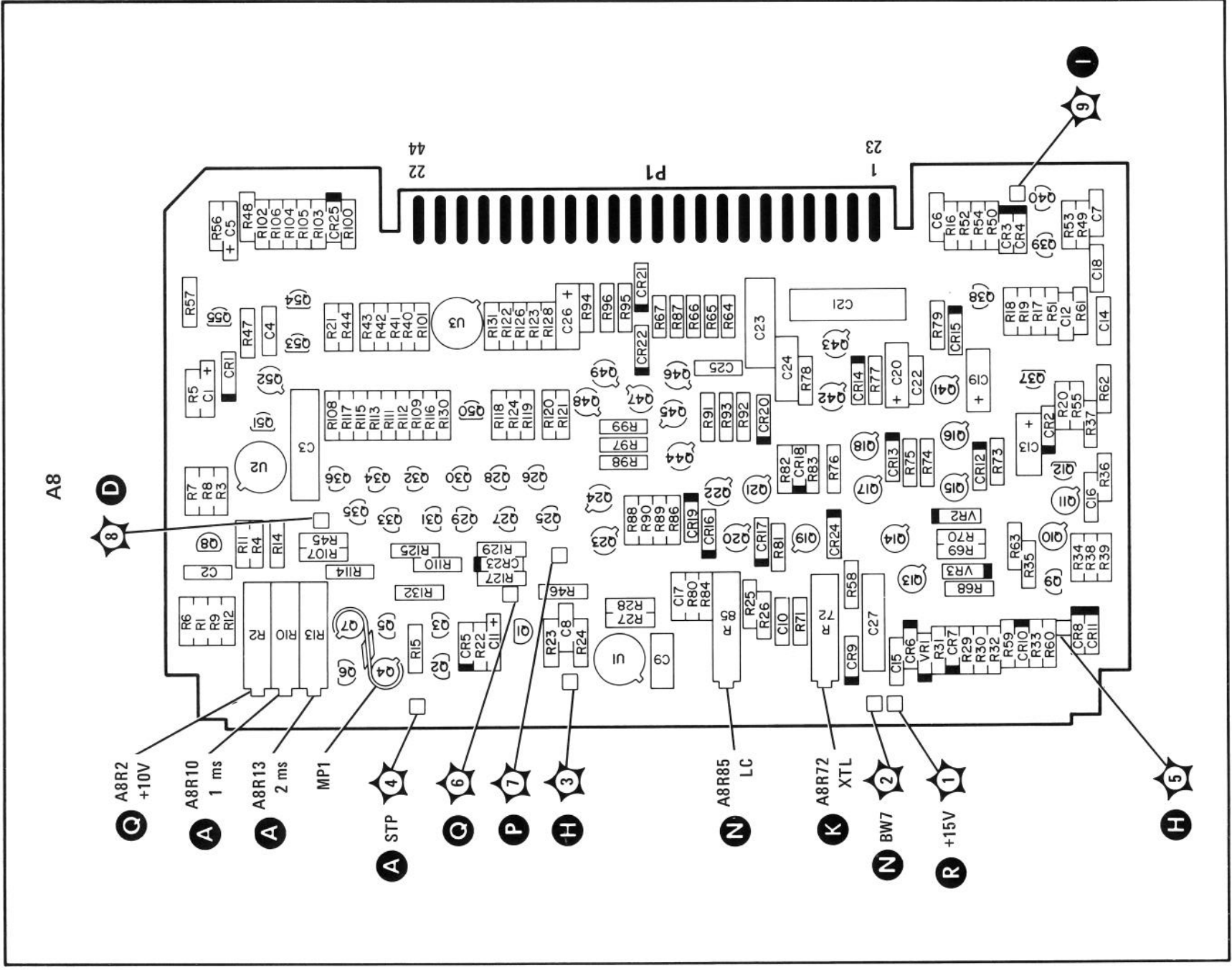
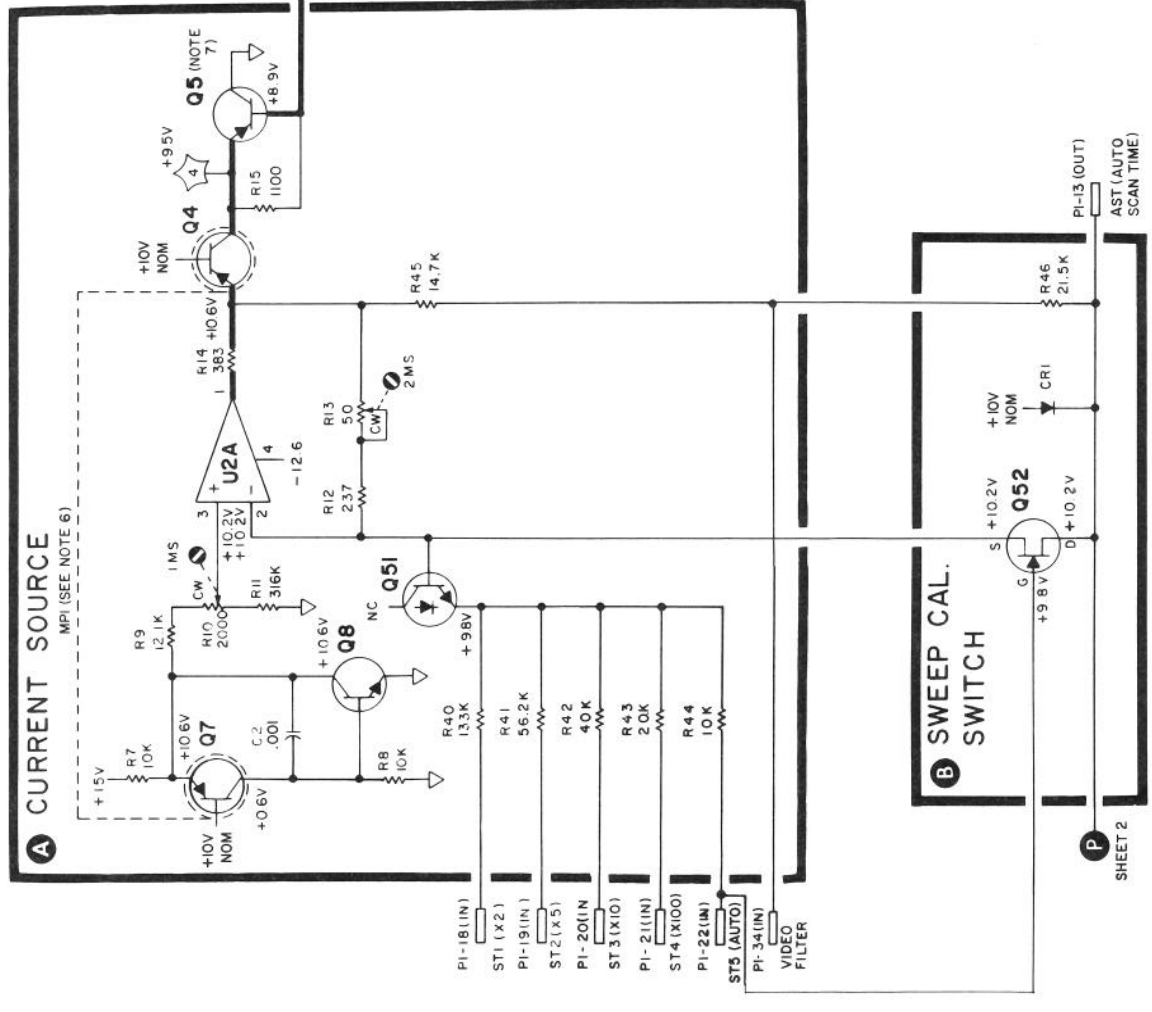
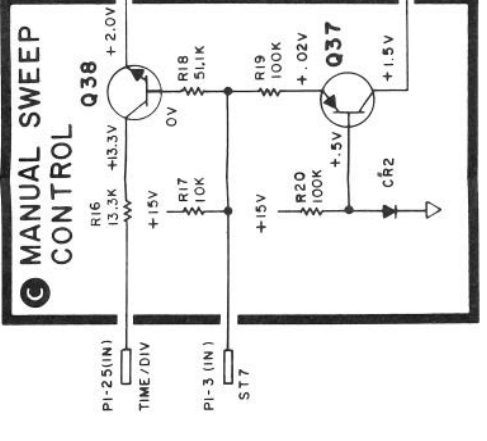
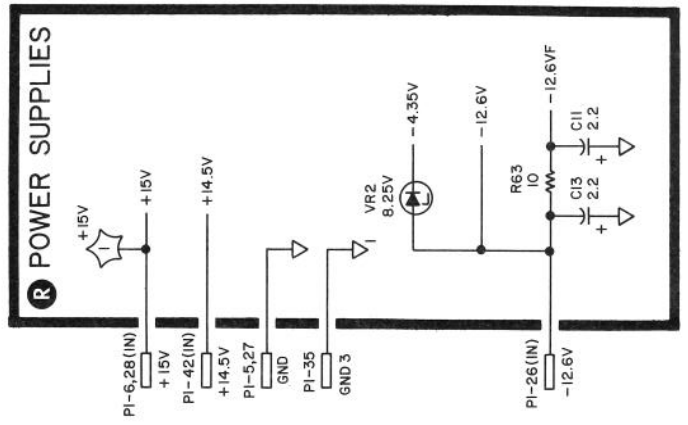
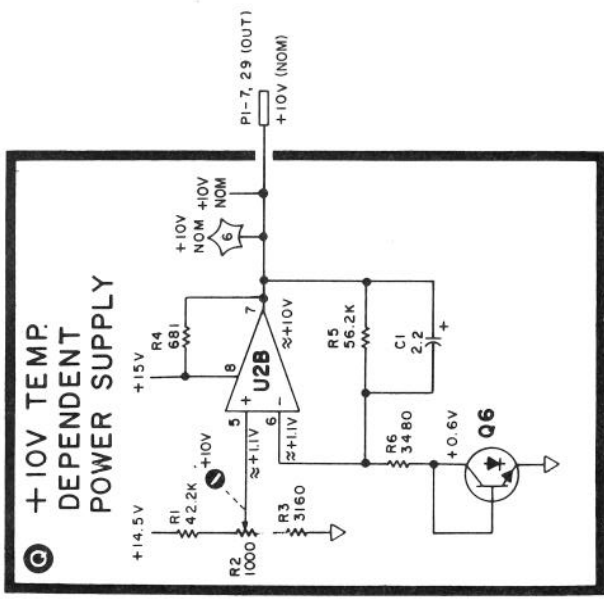

FIGURE 7-15. A8 SWEEP GENERATOR ASSEMBLY, COMPONENT AND TEST POINT LOCATIONS (2215A & BELOW)

A8 SWEEP GENERATOR

08558-60123

PIN	SIGNAL	TO/FROM	FUNCTION BLOCK
1	RETRACE BLANK TRIG	A15P1-19	H
23		A2A1	H
2	SYNC	A2A1	I
24	SINGLE	A2A1	J
3	ST7	A2A1	L
25	TIME/DIV	A2A1	L
4	VERT	A2R6	L
26	-12.6V	PI-28	R
5	GND		R
27			R
6	+15V	PI-29	R
28			R
7	+10V	A13P1-29	G
29		A11P1-29	G
		A12P1-29	G
8	BW1	A2A1	L O
30	BW5	A2A1	K N O
9	BW2	A2A1	L O
31	BW6	A11P1-31	K
		A13P1-31	K
10	BW3	A2A1	L O
32	BW7	A11P1-32	N
		A13P1-32	N
11	BW4	A2A1	L O
33	NOISE MEASURE	A2S2	O
12	ATTEN SWP	A7P1-30	D
34	VIDEO FILTER	A2R5	A
13	AST	REAR PANEL	B
35	GND 3	PI-20	R
14	NC		
36	F55	A2A1	P
15	F51	A2A1	P
37	F54	A2A1	P
16	F52	A2A1	P
38	F56	A2A1	P
17	F53	A2A1	P
39	SWEEP	A8P1-40	M
18	ST1	A2A1	A
40	SWEEP	A16R3	D
19	ST2	A2A1	A
41	ST-CTR	A2A1	M
20	ST3	A2A1	A
42	+14.5V	A7P1-10	R
21	ST4	A2A1	A
43	GND		NC
22	ST5	A2A1	A
44	ST6	A2A1	E



SHEET 2

MNEMONIC TABLE

MNEMONIC	DESCRIPTION
AST	AUTO SCAN TIME VOLTAGE
BW1-7	BANDWIDTH CONTROL LINES
FS1-6	FREQUENCY SPAN CONTROL LINES (FS2=ZERO SPAN, FS6=YIG MAIN/FM COIL)
GND3	GROUND (FROM A7 FREQUENCY CONTROL)
ST1-7	SCAN TIME CONTROL LINES (ST5=AUTO, ST6=SLOW/FAST, ST7=MANUAL)
ST-CTR	START-CENTER (LOW=START)
TIME/DIV	MANUAL SWEEP VOLTAGE
TRIG	TRIGGER (HIGH=FREE RUN)
VERT	FILTERED VIDEO SIGNAL

FOR COMPLETE LIST OF SIGNAL NAMES AND MNEMONICS, SEE A16 MOTHERBOARD SCHEMATIC.

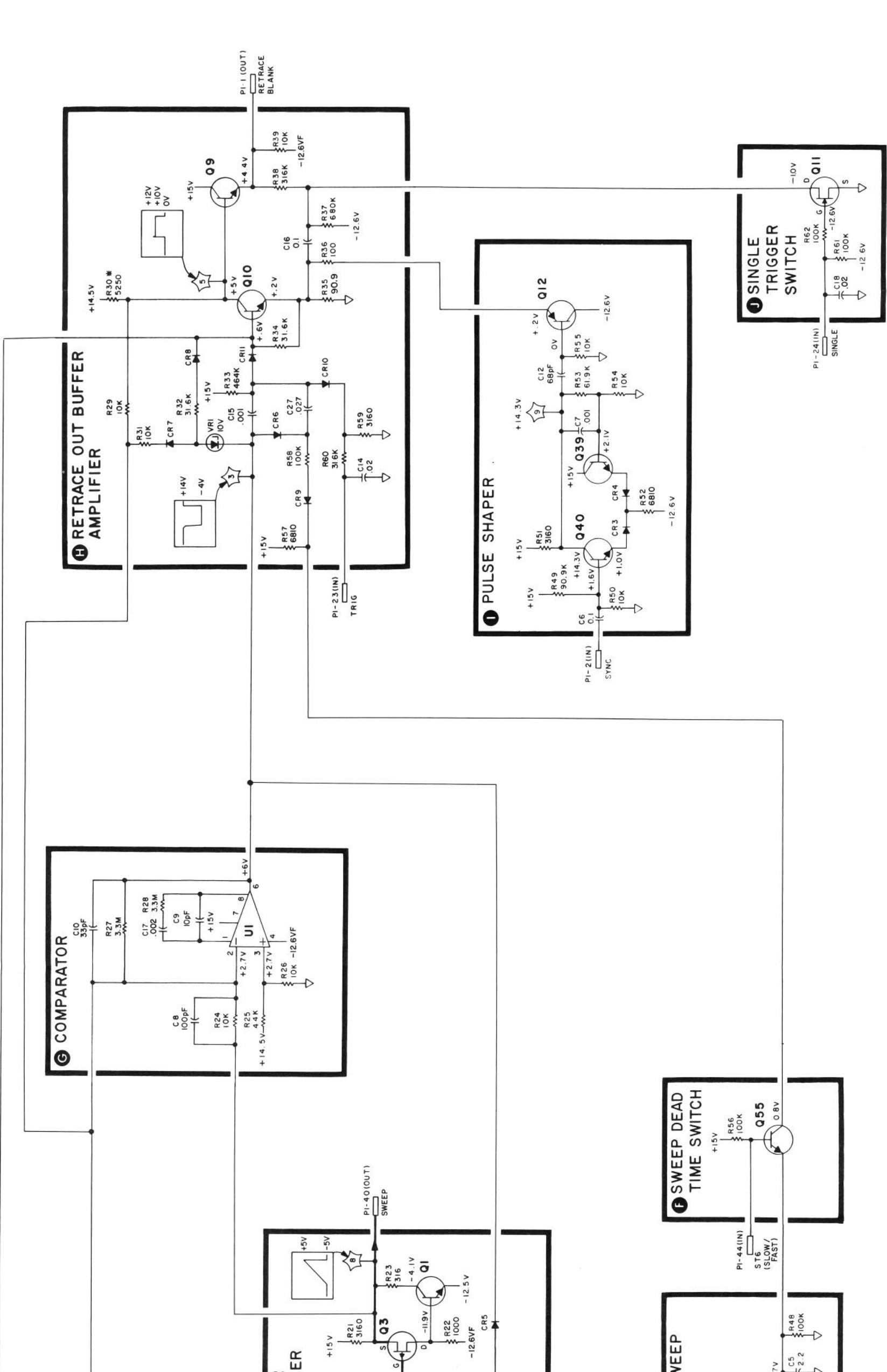

FIGURE 7-16. A8 SWEEP GENERATOR ASSEMBLY, SCHEMATIC DIAGRAM (1 OF 2) (2215 & BELOW)

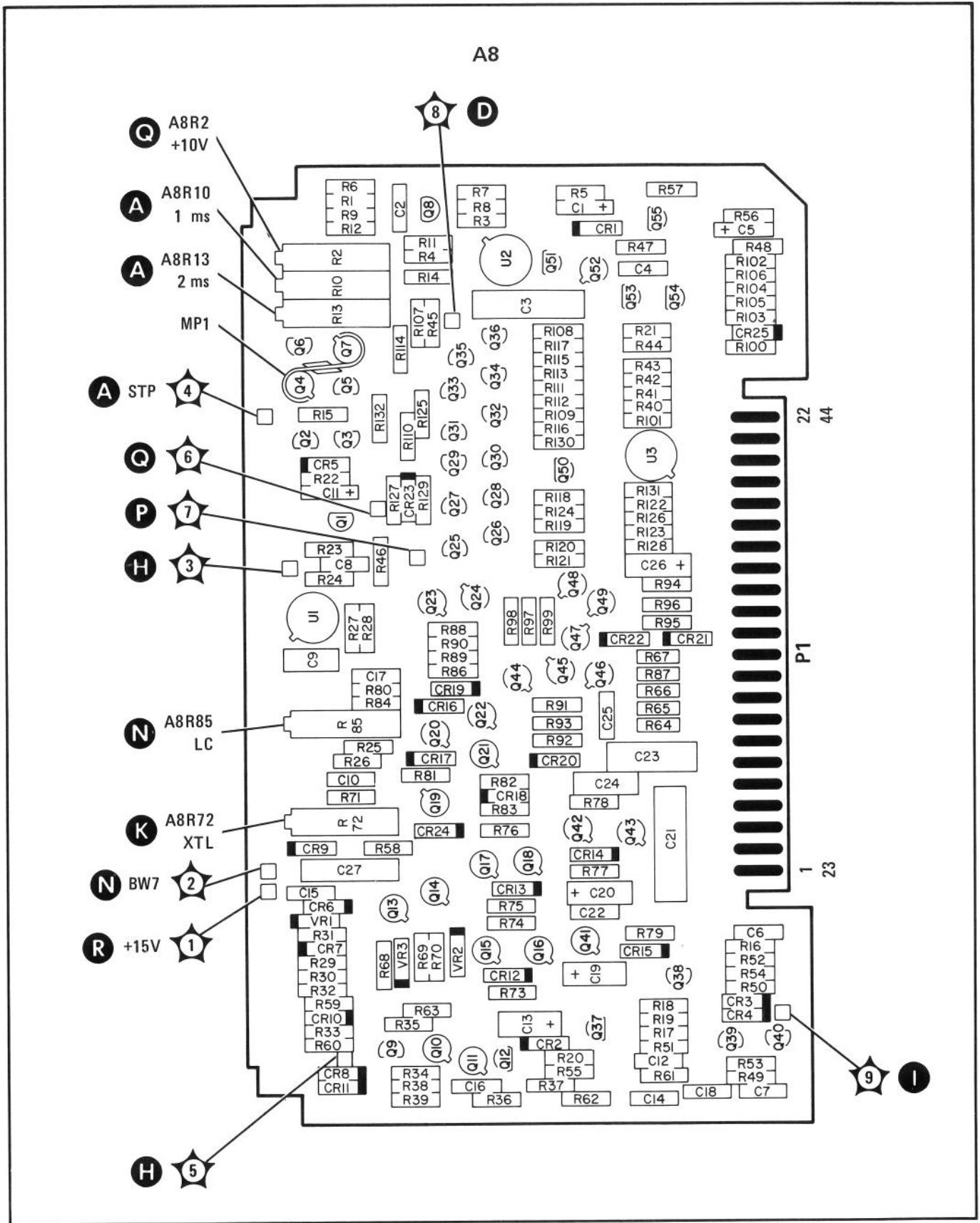

FIGURE 7-15. A8 SWEEP GENERATOR ASSEMBLY, COMPONENT AND TEST POINT LOCATIONS (2215A & BELOW)

NOTES

1. REFERENCE DESIGNATORS WITHIN THIS ASSEMBLY ARE ABBREVIATED, PREFIX ABBREVIATION WITH ASSEMBLY NUMBER FOR COMPLETE REFERENCE DESIGNATOR.
2. UNLESS OTHERWISE INDICATED: RESISTANCE IN OHMS (Ω) CAPACITANCE IN MICROFARADS (μ F) INDUCTANCE IN MICROHENRIES (μ H)
3. REFER TO FIGURE 8-2 FOR MEASUREMENT CONDITIONS.
4. BW CONTROL LINE TYPICAL VOLTAGES:

RESOLUTION BANDWIDTH	MODE BW CONTROL LINE TYPICAL VOLTAGES							
	XTAL	BW1	BW2	BW3	BW4	BW5	BW6	BW7
3 MHz	LC	-4	-4	-4	+15	-4	+7	
1 MHz	LC	-4	-4	+15	-4	+15	-4	+9
300 KHz	LC	-4	+15	-4	-4	+15	-4	+10
100 KHz	LC	+15	-4	-4	-4	+15	-4	+14
30 KHz	XTAL	-4	-4	-4	+15	-5	+10	+12
10 KHz	XTAL	-4	-4	+15	-4	-5	+10	+14
3 KHz	XTAL	-4	+15	-4	-4	-5	+9	+14
1 KHz	XTAL	+15	-4	-4	-4	-5	+7	+15

5. IC AND FET PIN CONFIGURATIONS (TOP VIEW):

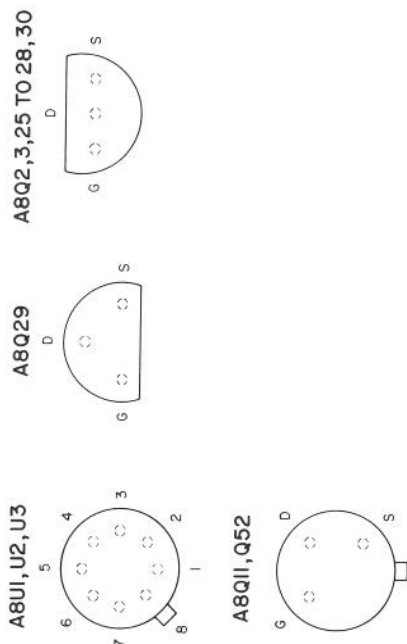

6. A8MP1 IS A THERMAL LINK. A8Q7 PROVIDES TEMPERATURE COMPENSATION FOR A8Q4.
7. A8Q5 IS A 1 mA CURRENT LIMITER.
8. REFER TO SHEET 1 FOR MNEMONIC TABLE.

A8

FIGURE 7-16. A8 SWEEP GENERATOR ASSEMBLY, SCHEMATIC DIAGRAM (2 OF 2) (2215 & BELOW) 7-83/7-84

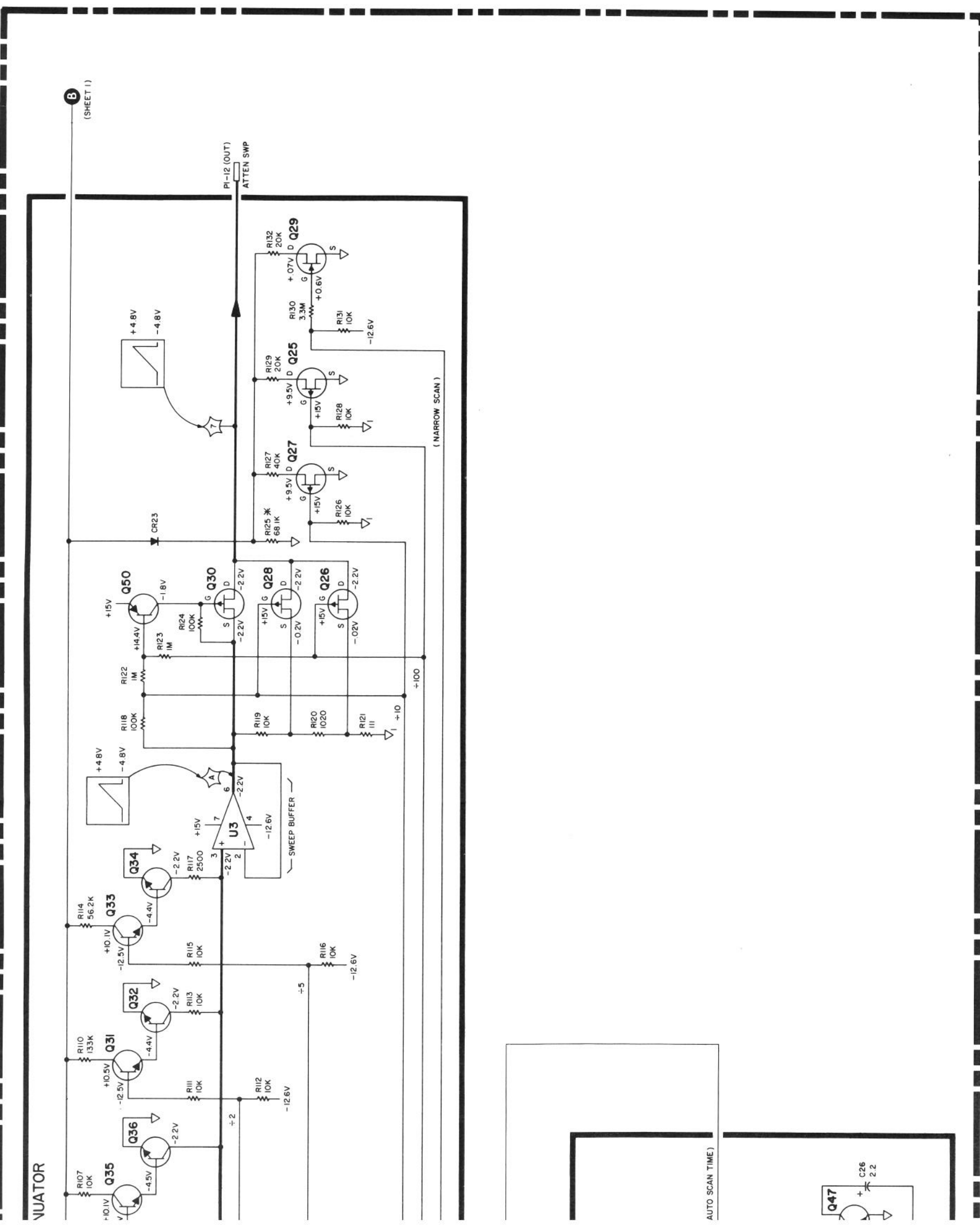

A8 SWEEP GENERATOR 08558-60123

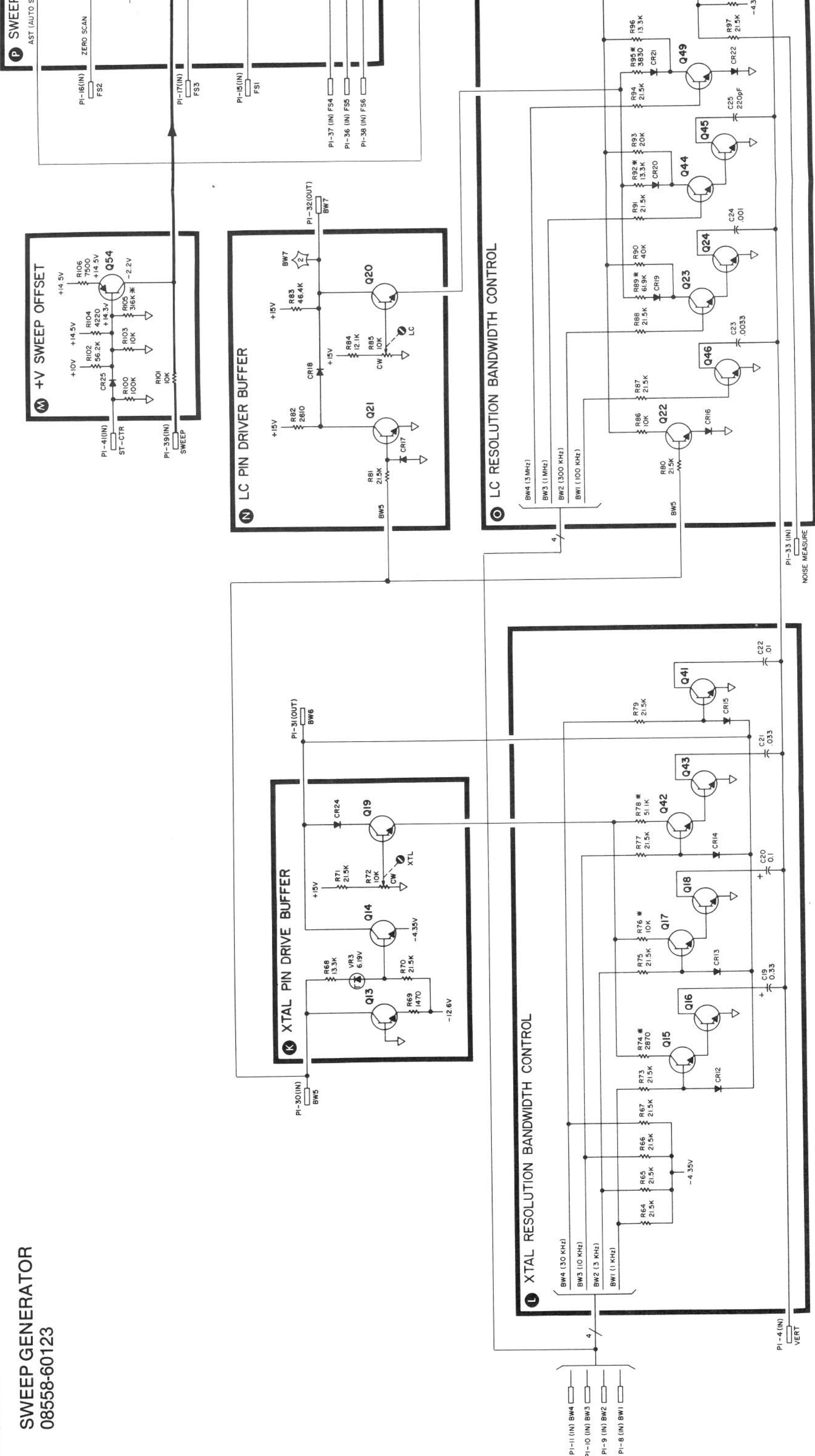

PAGES 8-87 THROUGH 8-95/8-96: A9 THIRD CONVERTER AND A10 SECOND IF ASSEMBLIES**A9 Third Converter, Circuit Description**

1926A prefixes and 1914A with suffixes 04747, 04918, 04993, 05158, 05160, 05172, 05228, 05229, 05252, 05281, 05297, 05300 thru 05307, 05311, 05312, 05313, 05316, 05318, 05320

Replace the circuit descriptions for the 21.4 MHz Amplifier (function block **(E)**) and PIN Driver (function block **(F)**) with the circuit descriptions provided below:

21.4 MHz Amplifier (E)

The 21.4 MHz Amplifier consists of A9Q3 in a common-emitter configuration and A9Q4 as an emitter follower. Transistor A9Q3 employs resistor A9R12 and zener diode A9VR2 to furnish base bias and negative feedback for gain control and stabilization. Resistor A9R12 is factory selected to provide the proper gain of the third converter assembly. Capacitor A9C14 is connected across A9VR2 to reduce zener noise. The output of the 21.4 MHz Amplifier looks into a voltage-controlled attenuator consisting of two PIN diodes, A9CR3 and CR4, resistor A9R25, and the input impedance of the A11 Bandwidth Filter No. 1.

Pin Driver (F)

The PIN diode resistance of A9CR3 and CR4 is controlled by the PIN driver A9Q5 and its associated circuitry. The base of A9Q5 is the summing point for the frequency analog voltage from the A7 Frequency Control and a dc level set by the front-panel REF LEVEL CAL screwdriver adjustment A2R3. Setting the dc level by adjusting A2R3 calibrates the 8558B display at a given frequency, usually performed at 280 MHz. The frequency analog voltage is a dc level varying from +0.6V to +6.7V as a function of frequency. This frequency analog voltage at the base of A9Q5 compensates for input mixer response. SLOPE COMP adjustment A9R1 sets the amount of compensation required for a flat frequency response. The total current through the PIN diodes A9CR3 and CR4 is shaped by the emitter network of A9Q5. This network provides a change in current through the PIN diodes to cause a change of PIN diode resistance. The change in resistance is required to provide the proper log curve within an 8 dB range for the voltage-controlled attenuator.

Table 8-9. A9 Third Converter, Replaceable Parts

2118A & Below	Change A9C5 to HP Part Number 0150-2251, Check Digit 6, Qty 1, CAPACITOR-FXD 5.6PF \pm .25PF. Delete A9C20. Add A9Y1, HP Part Number 0410-0447, Check Digit 0, Qty 1, CRYSTAL-QUARTZ FREQ=280 MHz 11th OVERTONE. Delete A9Z1.
1926A prefixes and 1914A with suffixes 04747, 04918, 04993, 05158, 05160, 05172, 05228, 05229, 05252, 05281, 05297, 05300 thru 05307, 05311, 05312, 05313, 05316, 05318, 05320	Delete A9C17, A9C18, A9C19, A9CR7, A9L15, and A9L16. Change A9R12* (standard instrument) to HP Part Number 0698-3132, Check Digit 4, Qty 1, RESISTOR 261 1% .125W F TC=0 \pm 100. Change A9R14* to A9R14, HP Part Number 0757-0462, Check Digit 3, Qty 1, RESISTOR 75K 1% .125W F TO=0 \pm 100. Change A9R25 to A9R25*.

Figure 8-32. A9 and A10, Component Locations

2118A & Below Replace Figure 8-32 with Figure 7-7 (2118A & BELOW) included in this Manual Backdating supplement.

1926A prefixes and Replace Figure 8-32 with Figure 7-9 included in this Manual
1914A with suffixes Backdating supplement.

04747, 04918, 04993,
05158, 05160, 05172,
05228, 05229, 05252,
05281, 05297, 05300
thru 05307, 05311,
05312, 05313, 05316,
05318, 05320

Figure 8-33. A9 and A10, Schematic Diagram

2118A & Below Replace function block (A) with function block (A) shown in Figure 7-8 (2118A & BELOW) included in this Manual Backdating supplement.

1926A prefixes and Replace function blocks (E) and (F) with function blocks (E) and
1914A with suffixes (F) shown in Figure 7-10, included in this Manual Backdating
supplement.

04747, 04918, 04993,
05158, 05160, 05172,
05228, 05229, 05252,
05281, 05297, 05300
thru 05307, 05311,
05312, 05313, 05316,
05318, 05320

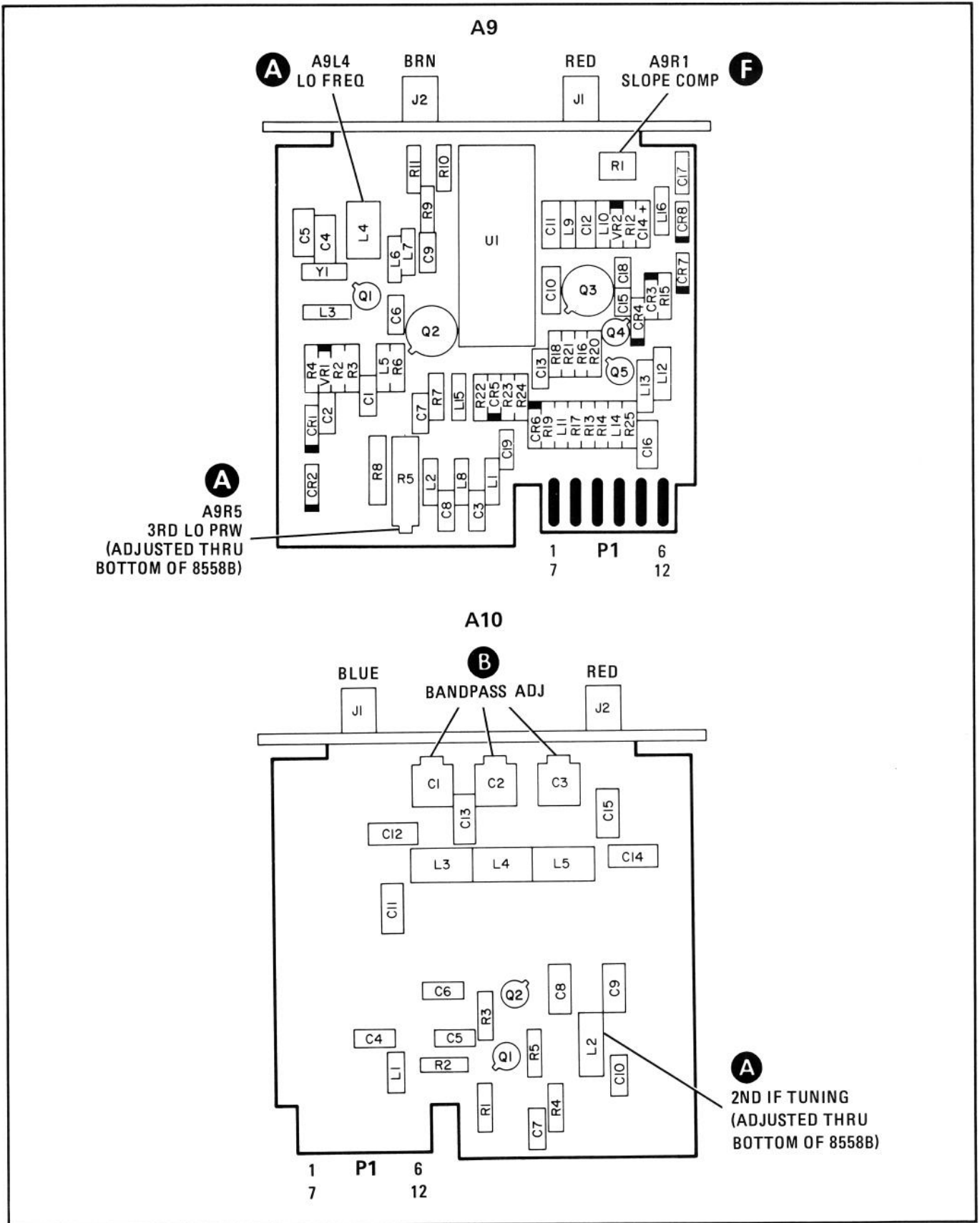

FIGURE 7-7. A9 THIRD CONVERTER AND A10 SECOND IF ASSEMBLIES, COMPONENT LOCATIONS (2118A & BELOW)

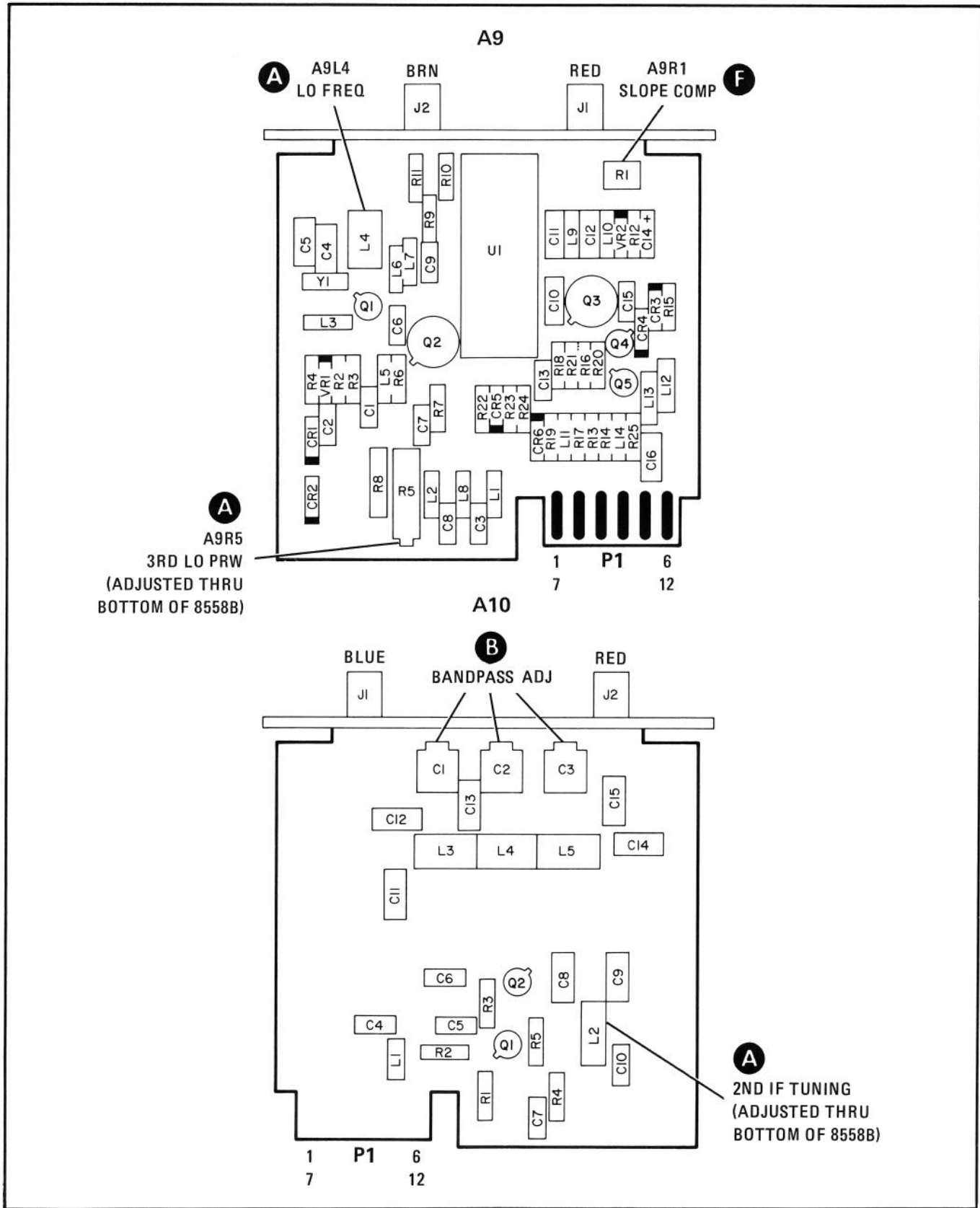

FIGURE 7-9. A9 THIRD CONVERTER AND A10 SECOND IF ASSEMBLIES, COMPONENT LOCATIONS

(1926A PREFIXES AND 1914A WITH SUFFIXES -04747, -04918, -04993, -05158, -05160, -05172, -05228, -05229, -05252, -05281, -05297, -05300 THROUGH -05307, -05311, -05312, -05313, -05316, -05318, -05320)

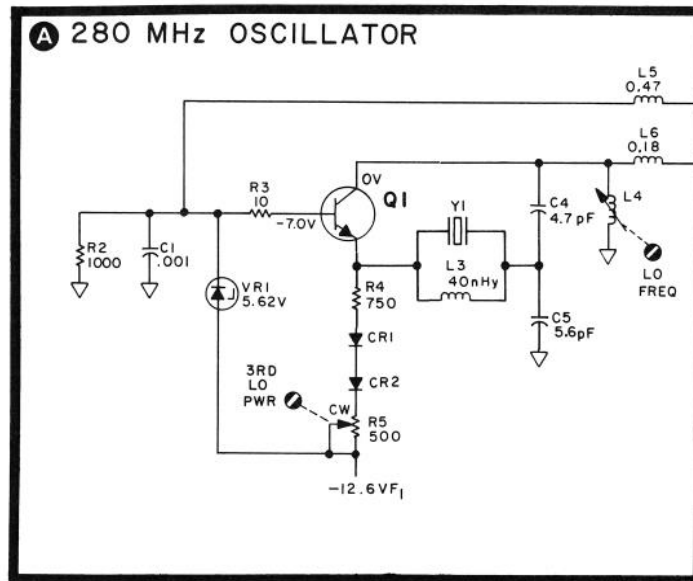

FIGURE 7-8. P/O A9 THIRD CONVERTER AND A10 SECOND IF ASSEMBLIES, SCHEMATIC DIAGRAM (2118A & BELOW)

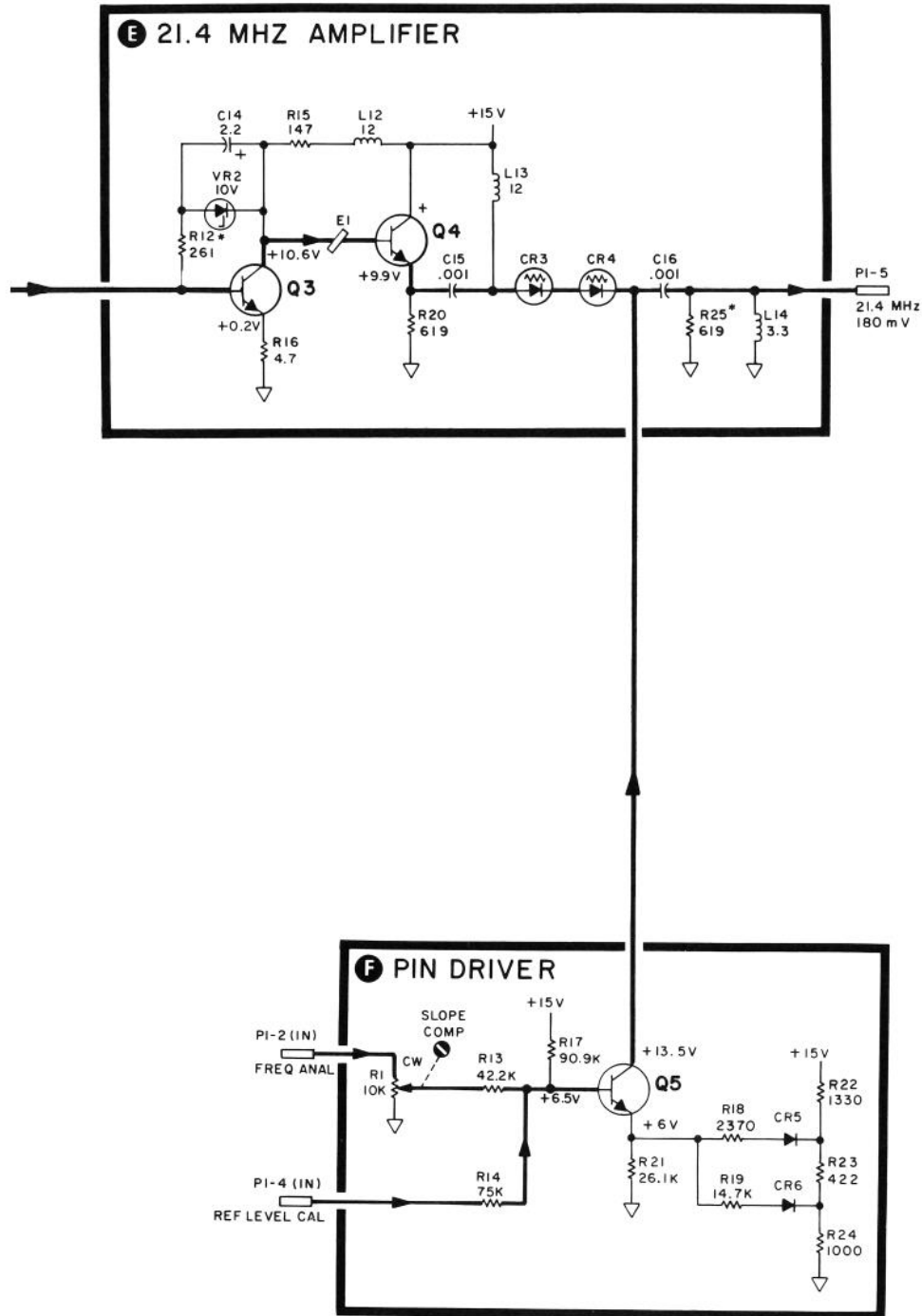

FIGURE 7-10. P/O A9 THIRD CONVERTER AND A10 SECOND IF ASSEMBLIES, SCHEMATIC DIAGRAM
 (1926A PREFIXES AND 1914A WITH SUFFIXES -04747, -04918, -04993, -05158, -05160, -05172, -05228, -05229, -05252, -05281, -05297, -05300 THROUGH -05307,
 -05311, -05312, -05313, -05316, -05318, -05320)

PAGES 8-97 THROUGH 8-109/8-110: A11 BANDWIDTH FILTER NO. 1 ASSEMBLY

- Figure 8-42. First LC Pole, Simplified Schematic**
 2147A & Below Replace Figure 8-42 with Figure 7-17 (2147A & BELOW), included in this Manual Backdating supplement.
- Table 8-11. A11 Bandwidth Filter No. 1, Replaceable Parts**
 2147A & Below Replace Table 8-11 with Table 7-9 (2147A & BELOW) included in this Manual Backdating supplement.
- In Table 7-9:
 2024A06643 thru Change A11C14 to HP Part Number 0160-2253, Check Digit 1, CAPACITOR-
 -06691, and FXD 6.8PF \pm .25PF 500VDC CER.
 2024A06731 Change A11C37 to HP Part Number 0160-2252, Check Digit 8, CAPACITOR-
 to, but not FXD 6.2PF \pm .25PF 500VDC CER.
 including,
 prefix 2118A,
 & Below.
- Figure 8-43. A11 Bandwidth Filter No. 1, Component Locations**
 2147A & Below Replace Figure 8-43 with Figure 7-18 (2147A & BELOW) included in this Manual Backdating supplement.
- Figure 8-44. A11 Bandwidth Filter No. 1, Schematic Diagram**
 2147A & Below Replace Figure 8-44 with Figure 7-19 (2147A & BELOW) included in this Manual Backdating supplement.
- In Figure 7-19:
 2024A06643 thru Change the value of C14 to 6.8 pF, and the value of C37 to 6.2 pF.
 -06691, and
 2024A06731 to,
 but not including,
 prefix 2118A,
 & Below.

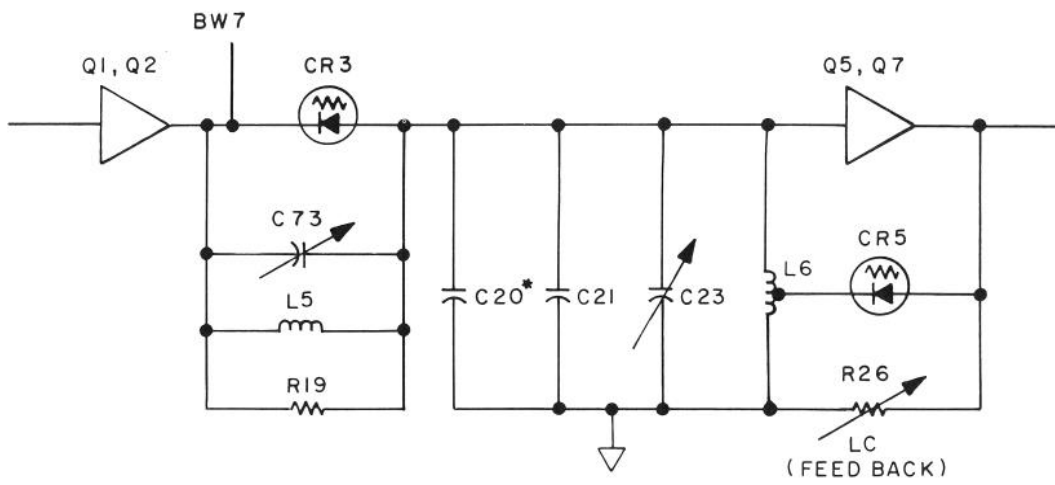

FIGURE 7-17. LC POLE, SIMPLIFIED SCHEMATIC (2147A & BELOW)

TABLE 7-9. A11 REPLACEABLE PARTS (2147A & BELOW)

Reference Designation	HP Part Number	C D	Qty	Description	Mfr Code	Mfr Part Number
A9U1	0955-0076	5	1	MIXER, DOUBLE BALANCED	28480	0955-0076
A9VR1	1902-3104	6	1	DIODE-ZNR 5.62V 5% DO-35 PD=.4W	28480	1902-3104
A9VR2	1902-0025	4		DIODE-ZNR 10V 5% DO-35 PD=.4W TC=+.06%	28480	1902-0025
A9Z1	1GA1-8001	3	1	SURFACE ACOUSTICAL WAVE RESONATOR(SAWR)	28480	1GA1-8001
A10	08558-60010	3	1	SECOND IF	28480	08558-60010
A10C1	0121-0457	9	3	CAPACITOR-V TRMR-PSTN .8-8.5PF 750V	18736	TP9
A10C2	0121-0457	9		CAPACITOR-FXD 1000PF +-20% 100VDC CER	18736	TP9
A10C3	0121-0457	9		CAPACITOR-V TRMR-PSTN .8-8.5PF 750V	18736	TP9
A10C4	0160-3878	6		CAPACITOR-FXD 1000PF +-20% 100VDC CER	28480	0160-3878
A10C5	0160-3878	6		CAPACITOR-FXD 1000PF +-20% 100VDC CER	28480	0160-3878
A10C6	0160-3877	5	1	CAPACITOR-FXD 100PF +-20% 200VDC CER	28480	0160-3877
A10C7	0160-3878	6		CAPACITOR-FXD 1000PF +-20% 100VDC CER	28480	0160-3878
A10C8	0160-2236	8	3	CAPACITOR-FXD 1PF +--.25PF 500VDC CER	28480	0160-2236
A10C9	0160-2250	6	9	CAPACITOR-FXD 5.1PF +--.25PF 500VDC CER	28480	0160-2250
A10C10	0160-3878	6		CAPACITOR-FXD 1000PF +-20% 100VDC CER	28480	0160-3878
A10C11	0160-2250	6		CAPACITOR-FXD 5.1PF +--.25PF 500VDC CER	28480	0160-2250
A10C12	0160-2250	6		CAPACITOR-FXD 5.1PF +--.25PF 500VDC CER	28480	0160-2250
A10C13	0160-2252	8	1	CAPACITOR-FXD 6.2PF +--.25PF 500VDC CER	28480	0160-2252
A10C14	0160-2250	6		CAPACITOR-FXD 5.1PF +--.25PF 500VDC CER	28480	0160-2250
A10C15	0160-2250	6		CAPACITOR-FXD 5.1PF +--.25PF 500VDC CER	28480	0160-2250
A10J1	1250-0830	6		CONNECTOR-RF SMC M SGL-HOLE-FR 50-OHM	28480	1250-0830
A10J2	1250-0830	6		CONNECTOR-RF SMC M SGL-HOLE-FR 50-OHM	28480	1250-0830
A10L1	9100-2247	4	2	INDUCTOR RF-CH-MLD 100NH 10% .105DX.26LG	28480	9100-2247
A10L2	08558-80005	8	1	COIL, PAR TANK	28480	08558-80005
A10L3	08558-80003	6	3	COIL, BANDPASS FILTER	28480	08558-80003
A10L4	08558-80003	6		COIL, BANDPASS FILTER	28480	08558-80003
A10L5	08558-80003	6		COIL, BANDPASS FILTER	28480	08558-80003
A10MP1	08558-00015	2	1	COVER, SECOND I.F.	28480	08558-00015
A10MP2	1200-0172	4	1	INSULATOR-XSTR DAP-GL	28480	1200-0172
A10Q1	1853-0007	7		TRANSISTOR PNP 2N3251 SI TO-18 PD=360MW	04713	2N3251
A10Q2	5086-4218	7		TRANSISTOR, NPN MICROWAVE	28480	5086-4218
A10R1	0757-0442	9		RESISTOR 10K 1% .125W F TC=0+-100	24546	C4-1/8-T0-1002-F
A10R2	0698-3136	8	3	RESISTOR 17.8K 1% .125W F TC=0+-100	24546	C4-1/8-T0-1782-F
A10R3	0757-0438	3		RESISTOR 5.11K 1% .125W F TC=0+-100	24546	C4-1/8-T0-5111-F
A10R4	0698-3442	9		RESISTOR 237 1% .125W F TC=0+-100	24546	C4-1/8-T0-237R-F
A10R5	0757-0280	3		RESISTOR 1K 1% .125W F TC=0+-100	24546	C4-1/8-T0-1001-F
A11	08558-60128	4	1	BANDWIDTH FILTER NO. 1	28480	08558-60128
A11C1	0160-2055	9		CAPACITOR-FXD .01UF +80-20% 100VDC CER	28480	0160-2055
A11C2	0160-0127	2	2	CAPACITOR-FXD 1UF +-20% 25VDC CER	28480	0160-0127
A11C3	0160-2236	8		CAPACITOR-FXD 1PF +--.25PF 500VDC CER	28480	0160-2236
A11C4	0160-2055	9		CAPACITOR-FXD .01UF +80-20% 100VDC CER	28480	0160-2055
A11C5	0160-2055	9		CAPACITOR-FXD .01UF +80-20% 100VDC CER	28480	0160-2055
A11C6	0160-2055	9		CAPACITOR-FXD .01UF +80-20% 100VDC CER	28480	0160-2055
A11C7	0160-2055	9		CAPACITOR-FXD .01UF +80-20% 100VDC CER	28480	0160-2055
A11C8	0160-2207	3		CAPACITOR-FXD 300PF +-5% 300VDC MICA	28480	0160-2207
A11C9	0160-2055	9		CAPACITOR-FXD .01UF +80-20% 100VDC CER	28480	0160-2055
A11C10	0160-2055	9		CAPACITOR-FXD .01UF +80-20% 100VDC CER	28480	0160-2055
A11C11	0160-2055	9		CAPACITOR-FXD .01UF +80-20% 100VDC CER	28480	0160-2055
A11C12	0160-2055	9		CAPACITOR-FXD .01UF +80-20% 100VDC CER	28480	0160-2055
A11C13	0160-3456	6		CAPACITOR-FXD 1000PF +-10% 1KVDC CER	28480	0160-3456
A11C14	0160-2250	6		CAPACITOR-FXD 5.1PF +--.25PF 500VDC CER	28480	0160-2250
A11C15	0121-0059	7	4	CAPACITOR-V TRMR-CER 2-8PF 350V PC-MTG	52763	304324 2/8PF NPO
A11C16				NOT ASSIGNED		
A11C17	0160-2055	9		CAPACITOR-FXD .01UF +80-20% 100VDC CER	28480	0160-2055
A11C18	0160-2055	9		CAPACITOR-FXD .01UF +80-20% 100VDC CER	28480	0160-2055
A11C19	0160-2055	9		CAPACITOR-FXD .01UF +80-20% 100VDC CER	28480	0160-2055
A11C20*	0140-0194	1	5	CAPACITOR-FXD 110PF +-5% 300VDC MICA	72136	DM15F111J0300WV1CR
A11C21	0160-3431	7	4	CAPACITOR-FXD 6.8PF +-5PF 500VDC CER	28480	0160-3431
A11C22	0160-4084	8		CAPACITOR-FXD .1UF +-20% 50VDC CER	28480	0160-4084
A11C23	0121-0036	0	4	CAPACITOR-V TRMR-CER 5.5-18PF 350V	52763	304324 5.5/18PF NPO
A11C24				NOT ASSIGNED		
A11C25	0121-0446	6	4	CAPACITOR-V TRMR-CER 4.5-20PF 160V	28480	0121-0446
A11C26	0160-2055	9		CAPACITOR-FXD .01UF +80-20% 100VDC CER	28480	0160-2055
A11C27	0160-2055	9		CAPACITOR-FXD .01UF +80-20% 100VDC CER	28480	0160-2055
A11C28	0160-2055	9		CAPACITOR-FXD .01UF +80-20% 100VDC CER	28480	0160-2055
A11C29	0160-3456	6		CAPACITOR-FXD 1000PF +-10% 1KVDC CER	28480	0160-3456
A11C30	0160-2055	9		CAPACITOR-FXD .01UF +80-20% 100VDC CER	28480	0160-2055
A11C31	0160-3456	6		CAPACITOR-FXD 1000PF +-10% 1KVDC CER	28480	0160-3456
A11C32	0160-4084	8		CAPACITOR-FXD .1UF +-20% 50VDC CER	28480	0160-4084
A11C33	0160-2207	3		CAPACITOR-FXD 300PF +-5% 300VDC MICA	28480	0160-2207
A11C34	0160-2055	9		CAPACITOR-FXD .01UF +80-20% 100VDC CER	28480	0160-2055
A11C35	0160-2055	9		CAPACITOR-FXD .01UF +80-20% 100VDC CER	28480	0160-2055

See introduction to this section for ordering information
 *Indicates factory selected value

TABLE 7-9. A11 REPLACEABLE PARTS (2147A & BELOW)

Reference Designation	HP Part Number	C D	Qty	Description	Mfr Code	Mfr Part Number
A11C36	0160-2055	9		CAPACITOR-FXD .01UF +80-20% 100VDC CER	28480	0160-2055
A11C37	0160-2250	6		CAPACITOR-FXD 5.1PF +- .25PF 500VDC CER	28480	0160-2250
A11C38	0121-0059	7		CAPACITOR-V TRMR-CER 2-8PF 350V PC-MTG	52763	304324 2/8PF NPO
A11C39				NOT ASSIGNED		
A11C40	0160-2055	9		CAPACITOR-FXD .01UF +80-20% 100VDC CER	28480	0160-2055
A11C41	0160-3456	6		CAPACITOR-FXD 1000PF +-10% 1KVDC CER	28480	0160-3456
A11C42	0160-2055	9		CAPACITOR-FXD .01UF +80-20% 100VDC CER	28480	0160-2055
A11C43	0160-3431	7		CAPACITOR-FXD 6.8PF +- .5PF 500VDC CER	28480	0160-3431
A11C44*	0140-0194	1		CAPACITOR-FXD 110PF +-5% 300VDC MICA	72136	DM15F111J0300WV1CR
A11C45	0121-0036	0		CAPACITOR-V TRMR-CER 5.5-18PF 350V	52763	304324 5.5/18PF NPO
A11C46	0160-4084	8		CAPACITOR-FXD .1UF +-20% 50VDC CER	28480	0160-4084
A11C47	0160-2055	9		CAPACITOR-FXD .01UF +80-20% 100VDC CER	28480	0160-2055
A11C48	0160-2055	9		CAPACITOR-FXD .01UF +80-20% 100VDC CER	28480	0160-2055
A11C49	0160-2055	9		CAPACITOR-FXD .01UF +80-20% 100VDC CER	28480	0160-2055
A11C50	0160-2055	9		CAPACITOR-FXD .01UF +80-20% 100VDC CER	28480	0160-2055
A11C51	0160-2055	9		CAPACITOR-FXD .01UF +80-20% 100VDC CER	28480	0160-2055
A11C52	0160-2055	9		CAPACITOR-FXD .01UF +80-20% 100VDC CER	28480	0160-2055
A11C53	0160-2055	9		CAPACITOR-FXD .01UF +80-20% 100VDC CER	28480	0160-2055
A11C54	0121-0446	6		CAPACITOR-V TRMR-CER 4.5-20PF 160V	28480	0121-0446
A11C55	0160-2055	9		CAPACITOR-FXD .01UF +80-20% 100VDC CER	28480	0160-2055
A11C56 THRU						
A11C59				NOT ASSIGNED		
A11C60	0160-2055	9		CAPACITOR-FXD .01UF +80-20% 100VDC CER	28480	0160-2055
A11C61	0160-2055	9		CAPACITOR-FXD .01UF +80-20% 100VDC CER	28480	0160-2055
A11C62	0160-2055	9		CAPACITOR-FXD .01UF +80-20% 100VDC CER	28480	0160-2055
A11C63	0160-2055	9		CAPACITOR-FXD .01UF +80-20% 100VDC CER	28480	0160-2055
A11C64	0160-2208	4	1	CAPACITOR-FXD 330PF +-5% 300VDC MICA	28480	0160-2208
A11C65	0160-2055	9		CAPACITOR-FXD .01UF +80-20% 100VDC CER	28480	0160-2055
A11C66	0160-2055	9		CAPACITOR-FXD .01UF +80-20% 100VDC CER	28480	0160-2055
A11C67	0160-2055	9		CAPACITOR-FXD .01UF +80-20% 100VDC CER	28480	0160-2055
A11C68 THRU						
A11C72				NOT ASSIGNED		
A11C73	0121-0452	4	4	CAPACITOR-V TRMR-AIR 1.3-5.4PF 175V	74970	187-0103-028
A11C74	0121-0452	4		CAPACITOR-V TRMR-AIR 1.3-5.4PF 175V	74970	187-0103-028
A11CR1	1901-0047	8	13	DIODE-SWITCHING 20V 75MA 10NS	28480	1901-0047
A11CR2	1901-0047	8		DIODE-SWITCHING 20V 75MA 10NS	28480	1901-0047
A11CR3	1901-1070	9		DIODE-PIN 110V	28480	1901-1070
A11CR4	1901-1070	9		DIODE-PIN 110V	28480	1901-1070
A11CR5	1901-1070	9		DIODE-PIN 110V	28480	1901-1070
A11CR6	1901-0535	9		DIODE-SM SIG SCHOTTKY	28480	1901-0535
A11CR7				NOT ASSIGNED		
A11CR8	1901-0535	9		DIODE-SM SIG SCHOTTKY	28480	1901-0535
A11CR9	1901-0047	8		DIODE-SWITCHING 20V 75MA 10NS	28480	1901-0047
A11CR10	1901-0047	8		DIODE-SWITCHING 20V 75MA 10NS	28480	1901-0047
A11CR11	1901-1070	9		DIODE-PIN 110V	28480	1901-1070
A11CR12	1901-1070	9		DIODE-PIN 110V	28480	1901-1070
A11CR13	1901-0047	8		DIODE-SWITCHING 20V 75MA 10NS	28480	1901-0047
A11CR14	1901-0535	9		DIODE-SM SIG SCHOTTKY	28480	1901-0535
A11CR15	1901-0535	9		DIODE-SM SIG SCHOTTKY	28480	1901-0535
A11CR16	1901-0047	8		DIODE-SWITCHING 20V 75MA 10NS	28480	1901-0047
A11CR17	1901-0535	9		DIODE-SM SIG SCHOTTKY	28480	1901-0535
A11E1 THRU						
A11E8	9170-0029	3		CORE-SHIELDING BEAD	28480	9170-0029
A11L1	9140-0112	2	3	INDUCTOR RF-CH-MLD 4.7UH 10%	28480	9140-0112
A11L2	9100-1641	0	4	INDUCTOR RF-CH-MLD 240UH 5% .166DX.385LG	28480	9100-1641
A11L3	9140-0114	4	7	INDUCTOR RF-CH-MLD 10UH 10% .166DX.385LG	28480	9140-0114
A11L4	9100-1624	9	6	INDUCTOR RF-CH-MLD 30UH 5% .166DX.385LG	28480	9100-1624
A11L5	9140-0179	1	14	INDUCTOR RF-CH-MLD 22UH 10% .166DX.385LG	28480	9140-0179
A11L6	9100-3854	1	4	INDUCTOR 400NH 10% .3DX1.016LG Q=150	28480	9100-3854
A11L7	9140-0098	3	4	INDUCTOR RF-CH-MLD 2.2UH 10%	28480	9140-0098
A11L8	9140-0178	0		INDUCTOR RF-CH-MLD 12UH 10% .166DX.385LG	28480	9140-0178
A11L9	9100-1641	0		INDUCTOR RF-CH-MLD 240UH 5% .166DX.385LG	28480	9100-1641
A11L10	9140-0114	4		INDUCTOR RF-CH-MLD 10UH 10% .166DX.385LG	28480	9140-0114
A11L11	9100-1624	9		INDUCTOR RF-CH-MLD 30UH 5% .166DX.385LG	28480	9100-1624
A11L12	9140-0179	1		INDUCTOR RF-CH-MLD 22UH 10% .166DX.385LG	28480	9140-0179
A11L13	9140-0098	3		INDUCTOR RF-CH-MLD 2.2UH 10%	28480	9140-0098
A11L14	9100-1620	5	2	INDUCTOR RF-CH-MLD 15UH 10% .166DX.385LG	28480	9100-1620
A11L15	9100-3854	1		INDUCTOR 400NH 10% .3DX1.016LG Q=150	28480	9100-3854
A11L16	9140-0144	0	3	INDUCTOR RF-CH-MLD 4.7UH 10% .105DX.26LG	28480	9140-0144
A11L17	9100-1624	9		INDUCTOR RF-CH-MLD 30UH 5% .166DX.385LG	28480	9100-1624
A11MP1	08565-00024	2	2	BAFFLE, INDUCTOR	28480	08565-00024
A11Q1	1854-0345	8		TRANSISTOR NPN 2N5179 SI T0-72 PD=200MW	04713	2N5179
A11Q2	1854-0404	0		TRANSISTOR NPN SI T0-18 PD=360MW	28480	1854-0404
A11Q3	1853-0007	7		TRANSISTOR PNP 2N3251 SI T0-18 PD=360MW	04713	2N3251
A11Q4	1853-0007	7		TRANSISTOR PNP 2N3251 SI T0-18 PD=360MW	04713	2N3251
A11Q5	1855-0267	5	4	TRANSISTOR J-FET N-CHAN D-MODE T0-92 SI	28480	1855-0267

See introduction to this section for ordering information
 *Indicates factory selected value

TABLE 7-9. A11 REPLACEABLE PARTS (2147A & BELOW)

Reference Designation	HP Part Number	C D	Qty	Description	Mfr Code	Mfr Part Number
A11Q6	1853-0007	7		TRANSISTOR PNP 2N3251 SI TO-18 PD=360MW	04713	2N3251
A11Q7	1854-0404	0		TRANSISTOR NPN SI TO-18 PD=360MW	28480	1854-0404
A11Q8	1853-0007	7		TRANSISTOR PNP 2N3251 SI TO-18 PD=360MW	04713	2N3251
A11Q9	1855-0267	5		TRANSISTOR J-FET N-CHAN D-MODE TO-92 SI	28480	1855-0267
A11Q10	1853-0007	7		TRANSISTOR PNP 2N3251 SI TO-18 PD=360MW	04713	2N3251
A11R1	0757-0444	1		RESISTOR 12.1K 1% .125W F TC=0+-100	24546	C4-1/8-T0-1212-F
A11R2	0698-3156	2		RESISTOR 14.7K 1% .125W F TC=0+-100	24546	C4-1/8-T0-1472-F
A11R3	0757-0402	1	6	RESISTOR 110 1% .125W F TC=0+-100	24546	C4-1/8-T0-111-F
A11R4				NOT ASSIGNED		
A11R5	0757-0405	4	2	RESISTOR 162 1% .125W F TC=0+-100	24546	C4-1/8-T0-162R-F
A11R6	0698-3431	6	2	RESISTOR 23.7 1% .125W F TC=0+-100	03888	PHE55-1/8-T0-23R7-F
A11R7	0698-8822	9	1	RESISTOR 6.81 1% .125W F TC=0+-100	28480	0698-8822
A11R8	0757-0401	0		RESISTOR 100 1% .125W F TC=0+-100	24546	C4-1/8-T0-101-F
A11R9	0757-0439	4		RESISTOR 6.81K 1% .125W F TC=0+-100	24546	C4-1/8-T0-6811-F
A11R10	0757-1094	9		RESISTOR 1.47K 1% .125W F TC=0+-100	24546	C4-1/8-T0-1471-F
A11R11	0757-0440	7		RESISTOR 7.5K 1% .125W F TC=0+-100	24546	C4-1/8-T0-7501-F
A11R12	0757-0447	4		RESISTOR 16.2K 1% .125W F TC=0+-100	24546	C4-1/8-T0-1622-F
A11R13	0698-0892	7	1	RESISTOR 464 1% .125W F TC=0+-100	24546	C4-1/8-T0-4640-F
A11R14	0757-0346	2		RESISTOR 10 1% .125W F TC=0+-100	24546	C4-1/8-T0-10R0-F
A11R15	0698-3440	7	9	RESISTOR 196 1% .125W F TC=0+-100	24546	C4-1/8-T0-196R-F
A11R16	0757-0419	0		RESISTOR 681 1% .125W F TC=0+-100	24546	C4-1/8-T0-681R-F
A11R17	0698-3442	9		RESISTOR 237 1% .125W F TC=0+-100	24546	C4-1/8-T0-237R-F
A11R18	0757-0279	0		RESISTOR 3.16K 1% .125W F TC=0+-100	24546	C4-1/8-T0-3161-F
A11R19	0757-0279	0		RESISTOR 3.16K 1% .125W F TC=0+-100	24546	C4-1/8-T0-3161-F
A11R20	0757-0442	9		RESISTOR 10K 1% .125W F TC=0+-100	24546	C4-1/8-T0-1002-F
A11R21	0757-0442	9		RESISTOR 10K 1% .125W F TC=0+-100	24546	C4-1/8-T0-1002-F
A11R22	0757-0442	9		RESISTOR 10K 1% .125W F TC=0+-100	24546	C4-1/8-T0-1002-F
A11R23*	0757-0289	2	14	RESISTOR 13.3K 1% .125W F TC=0+-100	19701	MS4C1/8-T0-1332F
A11R24	0757-0465	6		RESISTOR 100K 1% .125W F TC=0+-100	24546	C4-1/8-T0-1003-F
A11R25	0757-0465	6		RESISTOR 100K 1% .125W F TC=0+-100	24546	C4-1/8-T0-1003-F
A11R26	2100-3163	8	2	RESISTOR-TRMR 1M 20% C SIDE-ADJ 17-TRN	02111	43P105
A11R27	0757-0444	1		RESISTOR 12.1K 1% .125W F TC=0+-100	24546	C4-1/8-T0-1212-F
A11R28	0757-0290	5		RESISTOR 6.19K 1% .125W F TC=0+-100	19701	MF4C1/8-T0-6191-F
A11R29	0757-1094	9		RESISTOR 1.47K 1% .125W F TC=0+-100	24546	C4-1/8-T0-1471-F
A11R30	0757-0402	1		RESISTOR 110 1% .125W F TC=0+-100	24546	C4-1/8-T0-111-F
A11R31	2100-3052	4		RESISTOR-TRMR 50 10% C SIDE-ADJ 17-TRN	02111	43P500
A11R32				NOT ASSIGNED		
A11R33	0757-0442	9		RESISTOR 10K 1% .125W F TC=0+-100	24546	C4-1/8-T0-1002-F
A11R34	0757-0199	3		RESISTOR 21.5K 1% .125W F TC=0+-100	24546	C4-1/8-T0-2152-F
A11R35	0757-0288	1	5	RESISTOR 9.09K 1% .125W F TC=0+-100	19701	MF4C1/8-T0-9091-F
A11R36	0698-0883	8		RESISTOR 1.96K 1% .125W F TC=0+-100	24546	C4-1/8-T0-1961-F
A11R37	0757-0416	7		RESISTOR 511 1% .125W F TC=0+-100	24546	C4-1/8-T0-511R-F
A11R38	0698-3441	8	3	RESISTOR 215 1% .125W F TC=0+-100	24546	C4-1/8-T0-215R-F
A11R39	0757-0419	0		RESISTOR 681 1% .125W F TC=0+-100	24546	C4-1/8-T0-681R-F
A11R40	0698-3442	9		RESISTOR 237 1% .125W F TC=0+-100	24546	C4-1/8-T0-237R-F
A11R41	0757-0279	0		RESISTOR 3.16K 1% .125W F TC=0+-100	24546	C4-1/8-T0-3161-F
A11R42	0757-0442	9		RESISTOR 10K 1% .125W F TC=0+-100	24546	C4-1/8-T0-1002-F
A11R43*	0757-0200	7	4	RESISTOR 5.62K 1% .125W F TC=0+-100	24546	C4-1/8-T0-5621-F
A11R44	0757-0442	9		RESISTOR 10K 1% .125W F TC=0+-100	24546	C4-1/8-T0-1002-F
A11R45	0757-0401	0		RESISTOR 100 1% .125W F TC=0+-100	24546	C4-1/8-T0-101-F
A11R46	0757-0401	0		RESISTOR 100 1% .125W F TC=0+-100	24546	C4-1/8-T0-101-F
A11R47	0757-0346	2		RESISTOR 10 1% .125W F TC=0+-100	24546	C4-1/8-T0-10R0-F
A11R48*	0698-3156	2		RESISTOR 14.7K 1% .125W F TC=0+-100	24546	C4-1/8-T0-1472-F
A11R49	0757-0444	1		RESISTOR 12.1K 1% .125W F TC=0+-100	24546	C4-1/8-T0-1212-F
A11R50				NOT ASSIGNED		
A11R51	0757-0346	2		RESISTOR 10 1% .125W F TC=0+-100	24546	C4-1/8-T0-10R0-F
A11R52	0757-0290	5		RESISTOR 6.19K 1% .125W F TC=0+-100	19701	MF4C1/8-T0-6191-F
A11R53	0698-3440	7		RESISTOR 196 1% .125W F TC=0+-100	24546	C4-1/8-T0-196R-F
A11R54	0757-0416	7		RESISTOR 511 1% .125W F TC=0+-100	24546	C4-1/8-T0-511R-F
A11R55	0757-0442	9		RESISTOR 10K 1% .125W F TC=0+-100	24546	C4-1/8-T0-1002-F
A11R56*	0757-0424	7		RESISTOR 1.1K 1% .125W F TC=0+-100	24546	C4-1/8-T0-1101-F
A11R57	0757-0180	2	6	RESISTOR 31.6 1% .125W F TC=0+-100	28480	0757-0180
A11R58	0698-3152	8		RESISTOR 3.48K 1% .125W F TC=0+-100	24546	C4-1/8-T0-3481-F
A11R59	0757-0180	2		RESISTOR 31.6 1% .125W F TC=0+-100	28480	0757-0180
A11R60	0698-3153	9		RESISTOR 3.83K 1% .125W F TC=0+-100	24546	C4-1/8-T0-3831-F
A11TP1	0360-1788	7	8	CONNECTOR-SGL CONT PIN .045-IN-BSC-SZ SQ	28480	0360-1788
A11TP2	0360-1788	7		CONNECTOR-SGL CONT PIN .045-IN-BSC-SZ SQ	28480	0360-1788
A11TP3	1251-0600	0		CONNECTOR-SGL CONT PIN 1.14-MM-BSC-SZ SQ	28480	1251-0600
A11TP4	0360-1788	7		CONNECTOR-SGL CONT PIN .045-IN-BSC-SZ SQ	28480	0360-1788
A11TP5	0360-1788	7		CONNECTOR-SGL CONT PIN .045-IN-BSC-SZ SQ	28480	0360-1788
A11TP6	1251-0600	0		CONNECTOR-SGL CONT PIN 1.14-MM-BSC-SZ SQ	28480	1251-0600
A11TP7				NOT ASSIGNED		
A11TP8	1251-0600	0		CONNECTOR-SGL CONT PIN 1.14-MM-BSC-SZ SQ	28480	1251-0600
A11TP9	1251-0600	0		CONNECTOR-SGL CONT PIN 1.14-MM-BSC-SZ SQ	28480	1251-0600
A11TP10	1251-0600	0		CONNECTOR-SGL CONT PIN 1.14-MM-BSC-SZ SQ	28480	1251-0600

See introduction to this section for ordering information
 *Indicates factory selected value

TABLE 7-9. A11 REPLACEABLE PARTS (2147A & BELOW)

Reference Designation	HP Part Number	C D	Qty	Description	Mfr Code	Mfr Part Number
A11TP11	1251-0600	0		CONNECTOR-SGL CONT PIN 1.14-MM-BSC-SZ SQ	28480	1251-0600
A11VR1	1902-0048	1	2	DIODE-ZNR 6.81V 5% DO-35 PD=.4W	28480	1902-0048
A11Y1/2	0410-0450	5	2	CRYSTAL, 21.4 MHZ(MATCHED SET OF FOUR; INCLUDES A11Y1, A11Y2, A13Y1, & A13Y2)	28480	0410-0450
A12	08558-60012	5	1	STEP GAIN	28480	08558-60012
A12	08558-60073	8		STEP GAIN, OPTION 001/002	28480	08558-60073
A12C1	0160-2055	9		CAPACITOR-FXD .01UF +80-20% 100VDC CER	28480	0160-2055
A12C2	0160-2055	9		CAPACITOR-FXD .01UF +80-20% 100VDC CER	28480	0160-2055
A12C3	0160-2055	9		CAPACITOR-FXD .01UF +80-20% 100VDC CER	28480	0160-2055
A12C4	0160-2055	9		CAPACITOR-FXD .01UF +80-20% 100VDC CER	28480	0160-2055
A12C5	0160-2055	9		CAPACITOR-FXD .01UF +80-20% 100VDC CER	28480	0160-2055
A12C6	0160-2055	9		CAPACITOR-FXD .01UF +80-20% 100VDC CER	28480	0160-2055
A12C7	0160-2055	9		CAPACITOR-FXD .01UF +80-20% 100VDC CER	28480	0160-2055
A12C8	0160-2055	9		CAPACITOR-FXD .01UF +80-20% 100VDC CER	28480	0160-2055
A12C9	0160-2055	9		CAPACITOR-FXD .01UF +80-20% 100VDC CER	28480	0160-2055
A12C10	0160-2055	9		CAPACITOR-FXD .01UF +80-20% 100VDC CER	28480	0160-2055
A12C11	0160-2055	9		CAPACITOR-FXD .01UF +80-20% 100VDC CER	28480	0160-2055
A12C12	0180-0291	3	2	CAPACITOR-FXD 1UF+10% 35VDC TA	56289	150D105X9035A2
A12C13	0160-2055	9		CAPACITOR-FXD .01UF +80-20% 100VDC CER	28480	0160-2055
A12C14	0160-2055	9		CAPACITOR-FXD .01UF +80-20% 100VDC CER	28480	0160-2055
A12C15	0160-2055	9		CAPACITOR-FXD .01UF +80-20% 100VDC CER	28480	0160-2055
A12C16	0160-3457	7		CAPACITOR-FXD 2000PF +-10% 250VDC CER	28480	0160-3457
A12C17	0160-2055	9		CAPACITOR-FXD .01UF +80-20% 100VDC CER	28480	0160-2055
A12C18	0160-2055	9		CAPACITOR-FXD .01UF +80-20% 100VDC CER	28480	0160-2055
A12C19	0160-3457	7		CAPACITOR-FXD 2000PF +-10% 250VDC CER	28480	0160-3457
A12C20	0160-2055	9		CAPACITOR-FXD .01UF +80-20% 100VDC CER	28480	0160-2055
A12C21	0160-2055	9		CAPACITOR-FXD .01UF +80-20% 100VDC CER	28480	0160-2055
A12C22	0160-3457	7		CAPACITOR-FXD 2000PF +-10% 250VDC CER	28480	0160-3457
A12C23	0160-2055	9		CAPACITOR-FXD .01UF +80-20% 100VDC CER	28480	0160-2055
A12C24	0160-2199	2	1	CAPACITOR-FXD 30PF +-5% 300VDC MICA	28480	0160-2199
A12C25	0160-2307	4	1	CAPACITOR-FXD 47PF +-5% 300VDC MICA	28480	0160-2307
A12C26	0140-0194	1		CAPACITOR-FXD 110PF +-5% 300VDC MICA	72136	DM15F111J0300VV1CR
A12C27	0180-0291	3		CAPACITOR-FXD 1UF+-10% 35VDC TA	56289	150D105X9035A2
A12CR1	1901-0050	3		DIODE-SWITCHING 80V 200MA 2NS DO-35	28480	1901-0050
A12CR2	1901-0050	3		DIODE-SWITCHING 80V 200MA 2NS DO-35	28480	1901-0050
A12CR3	1901-1070	9		DIODE-PIN 110V	28480	1901-1070
A12CR4	1901-1070	9		DIODE-PIN 110V	28480	1901-1070
A12CR5	1901-1070	9		DIODE-PIN 110V	28480	1901-1070
A12CR6	1901-1070	9		DIODE-PIN 110V	28480	1901-1070
A12E1	9170-0029	3		CORE-SHIELDING BEAD	28480	9170-0029
A12E2	9170-0029	3		CORE-SHIELDING BEAD	28480	9170-0029
A12E3	9170-0029	3		CORE-SHIELDING BEAD	28480	9170-0029
A12L1	9140-0179	1		INDUCTOR RF-CH-MLD 22UH 10% .166DX.385LG	28480	9140-0179
A12L2	9140-0179	1		INDUCTOR RF-CH-MLD 22UH 10% .166DX.385LG	28480	9140-0179
A12L3	9140-0179	1		INDUCTOR RF-CH-MLD 22UH 10% .166DX.385LG	28480	9140-0179
A12L4	9140-0179	1		INDUCTOR RF-CH-MLD 22UH 10% .166DX.385LG	28480	9140-0179
A12L5	9140-0179	1		INDUCTOR RF-CH-MLD 22UH 10% .166DX.385LG	28480	9140-0179
A12L6	9140-0179	1		INDUCTOR RF-CH-MLD 22UH 10% .166DX.385LG	28480	9140-0179
A12L7	9140-0179	1		INDUCTOR RF-CH-MLD 22UH 10% .166DX.385LG	28480	9140-0179
A12L8	9140-0179	1		INDUCTOR RF-CH-MLD 22UH 10% .166DX.385LG	28480	9140-0179
A12L9	9100-2260	1	1	INDUCTOR RF-CH-MLD 1.8UH 10% .105DX.26LG	28480	9100-2260
A12L10	9140-0158	6	5	INDUCTOR RF-CH-MLD 1UH 10% .105DX.26LG	28480	9140-0158
A12L11	9100-2552	4	4	INDUCTOR RF-CH-MLD 15UH 10% .161DX.385LG	28480	9100-2552
A12Q1	1853-0007	7		TRANSISTOR PNP 2N3251 SI TO-18 PD=360MW	04713	2N3251
A12Q2	1854-0345	8		TRANSISTOR NPN 2N5179 SI TO-72 PD=200MW	04713	2N5179
A12Q3	1853-0007	7		TRANSISTOR PNP 2N3251 SI TO-18 PD=360MW	04713	2N3251
A12Q4	1854-0345	8		TRANSISTOR NPN 2N5179 SI TO-72 PD=200MW	04713	2N5179
A12Q5	1853-0007	7		TRANSISTOR PNP 2N3251 SI TO-18 PD=360MW	04713	2N3251
A12Q6	1854-0345	8		TRANSISTOR NPN 2N5179 SI TO-72 PD=200MW	04713	2N5179
A12Q7	1853-0007	7		TRANSISTOR PNP 2N3251 SI TO-18 PD=360MW	04713	2N3251
A12Q8	1853-0007	7		TRANSISTOR PNP 2N3251 SI TO-18 PD=360MW	04713	2N3251
A12Q9	1853-0007	7		TRANSISTOR PNP 2N3251 SI TO-18 PD=360MW	04713	2N3251
A12Q10	1854-0882	8		TRANSISTOR NPN PD=300MW FT=200MHZ	28480	1854-0882
A12Q11	1854-0882	8		TRANSISTOR NPN PD=300MW FT=200MHZ	28480	1854-0882
A12Q12	1853-0007	7		TRANSISTOR PNP 2N3251 SI TO-18 PD=360MW	04713	2N3251
A12Q13	1853-0213	7	1	TRANSISTOR PNP 2N4236 SI TO-5 PD=1W	04713	2N4236
A12R1	2100-3103	6	3	RESISTOR-TRMR 10K 10% C SIDE-ADJ 17-TRN	02111	43P103
A12R2	2100-3103	6		RESISTOR-TRMR 10K 10% C SIDE-ADJ 17-TRN	02111	43P103
A12R3	2100-3054	6	1	RESISTOR-TRMR 50K 10% C SIDE-ADJ 17-TRN	02111	43P503
A12R4	2100-3061	5	1	RESISTOR-TRMR 500K 10% C SIDE-ADJ 17-TRN	02111	43P504
A12R5	2100-3103	6		RESISTOR-TRMR 10K 10% C SIDE-ADJ 17-TRN	02111	43P103

See introduction to this section for ordering information
*Indicates factory selected value

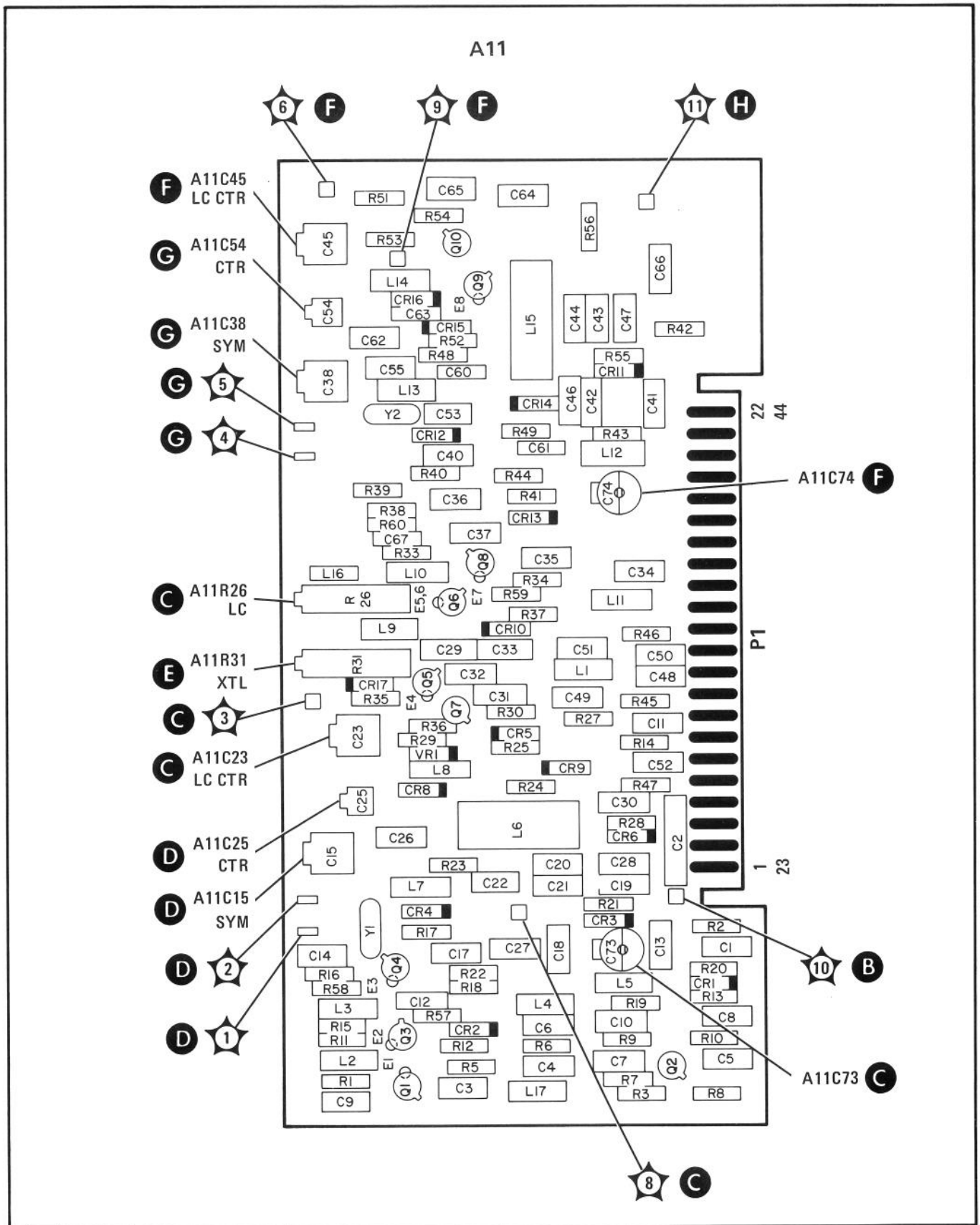
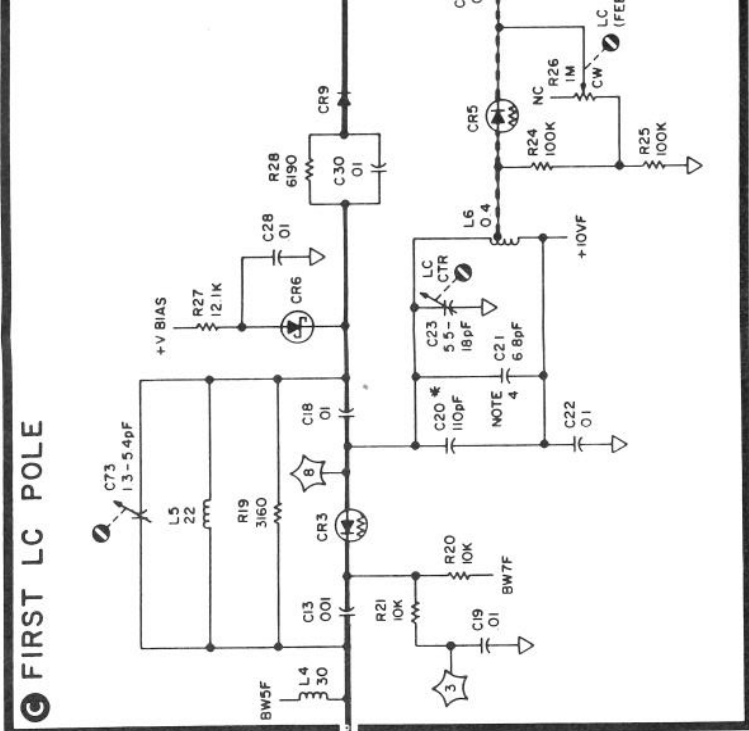
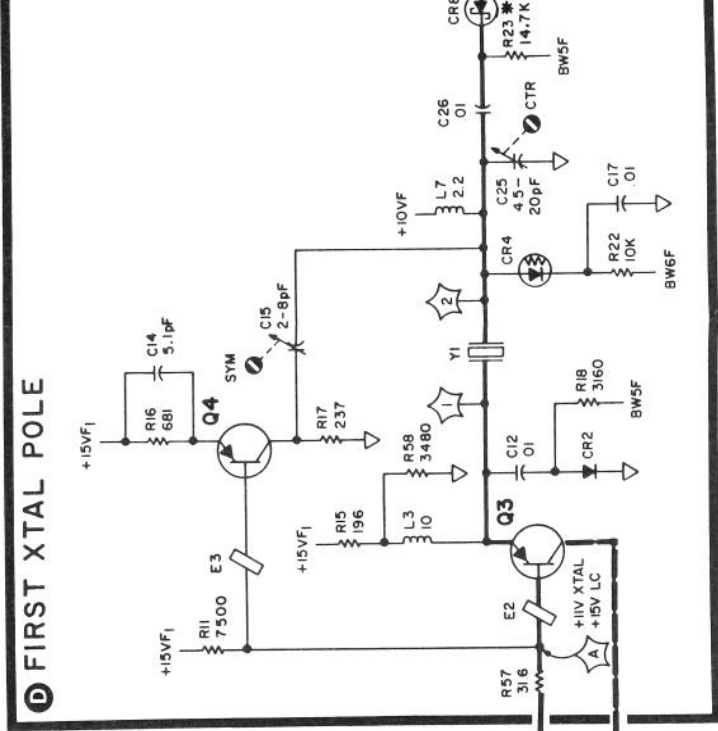
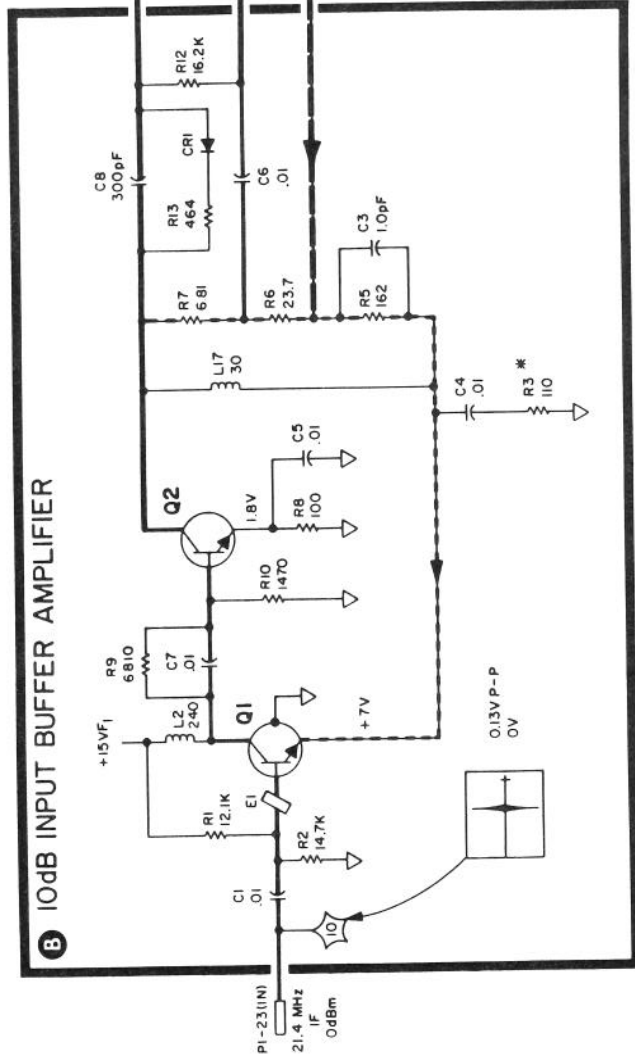
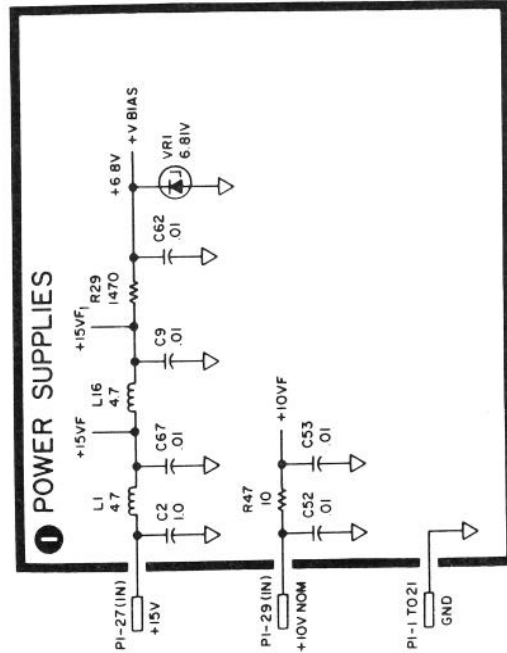
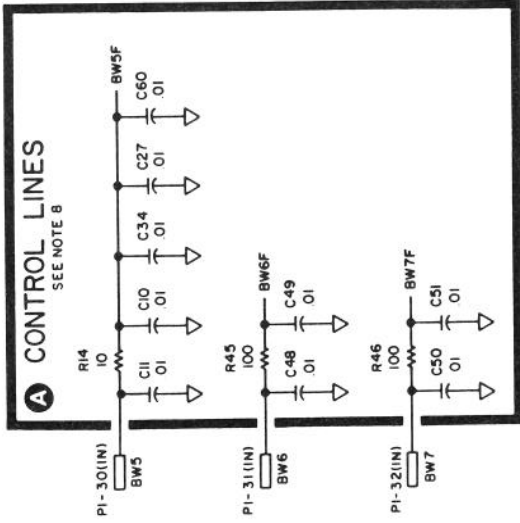

FIGURE 7-18. A11 BANDWIDTH FILTER NO. 1, COMPONENT AND TEST POINT LOCATIONS (2147A & BELOW)

A11 BANDWIDTH FILTER NO.1

08558-60128

PIN	SIGNAL	TO/FROM	FUNCTION BLOCK
1	GND		(1)
23	21.4 MHz IF	ASP1.5	(1)
2	GND		(1)
24	NC		(1)
3	GND		(1)
25	NC		(1)
4	GND		(1)
26	NC		(1)
5	GND	REAR PANEL	(1)
27	+15V	PI.25	(1)
6	GND		(1)
28	NC		(1)
7	GND		(1)
29	+10V NOM	ASP1.7.25	(1)
8	GND	A2	(1)
30	BWS	ABP1.30	(A)
9	GND	BWS	(A)
31	BWS	ABP1.31	(A)
10	GND		(1)
32	BW7	ABP1.32	(A)
11	GND		(1)
33	NC		(1)
12	GND		(1)
34	NC		(1)
13	GND		(1)
35	NC		(1)
14	GND		(1)
36	NC		(1)
15	GND		(1)
37	NC		(1)
16	GND		(1)
38	NC		(1)
17	GND		(1)
39	NC		(1)
18	GND		(1)
40	NC		(1)
19	GND		(1)
41	NC		(1)
20	GND		(1)
42	NC		(1)
21	GND		(1)
43	NC		(1)
22	21.4 MHz IF	A12P1.44	(H)
44	NC		(1)



NOTES

1. REFERENCE DESIGNATORS WITHIN THIS ASSEMBLY ARE ABBREVIATED, PREFIX ABBREVIATION WITH ASSEMBLY NUMBER FOR COMPLETE REFERENCE DESIGNATOR.
2. UNLESS OTHERWISE INDICATED: RESISTANCE IN OHMS (Ω) CAPACITANCE IN MICROFARADS (μ F) INDUCTANCE IN MICROHENRIES (μ H)
3. REFER TO FIGURE 8-2 FOR MEASUREMENT CONDITIONS.
4. TEMPERATURE COMPENSATING CAPACITOR.
5. ASTERISK (*) DENOTES FACTORY SELECTED COMPONENT. NOMINAL VALUE IS SHOWN.
6. SOURCE VOLTAGE SHOULD BE 0.2V TO 1.5V GREATER THAN THE GATE VOLTAGE.
7. VOLTAGES SHOULD BE MEASURED WITH 1K Ω OR GREATER AT PROBE TIP TO PREVENT OSCILLATION AND ERRONEOUS READINGS.

BANDWIDTH	BW CON-TROL LINES TYPICAL VOLTAGES	BW6 XTAL LC	BW7 LC
3 MHz	+15	-4	+7
1 MHz	+15	-4	+9
300 kHz	+15	-4	+10
100 kHz	+15	-4	+14
30 kHz	-5	+10	+12
10 kHz	-5	+10	+14
3 kHz	-5	+9	+14
1 kHz	-5	+7	+15

8.  DESIGNATES SHIELDING BEAD.

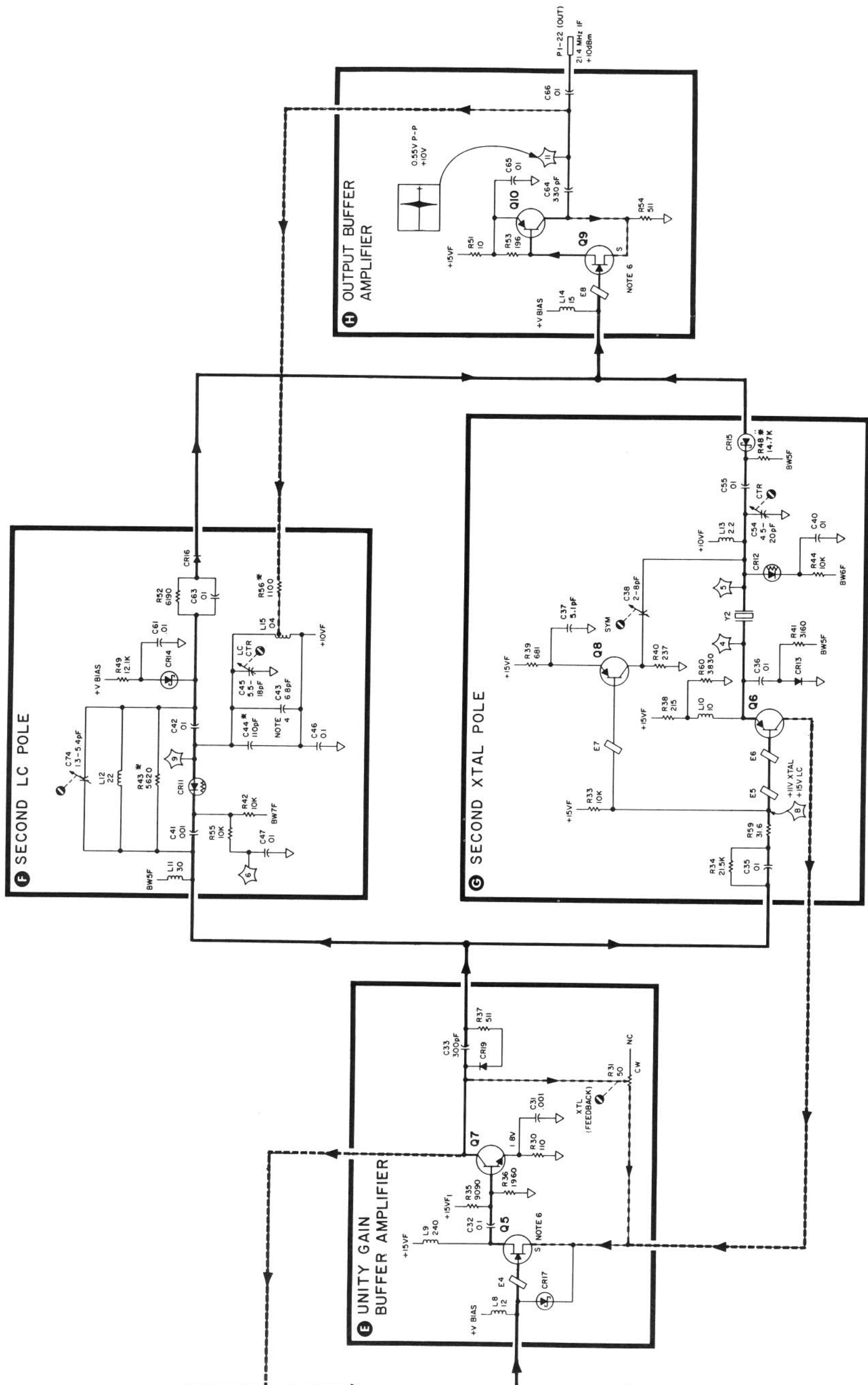

FIGURE 7-19. A11 BANDWIDTH FILTER NO. 1, SCHEMATIC DIAGRAM (2147A & BELOW)

A11

PAGES 8-119/8-120 THROUGH 8-125/8-126: A13 BANDWIDTH FILTER NO. 2 ASSEMBLY**Table 8-13. A13 Bandwidth Filter No. 2, Replaceable Parts**

2147A & Below Replace Table 8-13 with Table 7-10 (2147A & BELOW) included in this Manual Backdating supplement.

In Table 7-10:

2024A06643 thru
-06691, and

Change A13C14 to HP Part Number 0160-2253, Check Digit 9, CAPACITOR-
FXD 6.8PF \pm .25PF 500VDC CER.

2024A06731
to, but not
including,
prefix 2118A,
& Below.

Change A13C37 to HP Part Number 0160-2252, Check digit 8, CAPACITOR-
FXD 6.2PF \pm .25PF 500VDC CER.

Figure 8-48. A13 Bandwidth Filter No. 2, Component Locations

2147A & Below Replace Figure 8-48 with Figure 7-20 (2147A & BELOW) included in this Manual Backdating supplement.

Figure 8-49. A13 Bandwidth Filter No. 2, Schematic Diagram

2147A & Below Replace Figure 8-49 with Figure 7-21 (2147A & BELOW) included in this Manual Backdating supplement.

In Figure 7-21:

2024A06643 thru
-06691, and
2024A06731 to,
but not including,
prefix 2118A,
& Below.

Change the value of C14 to 6.8 pF, and the value of C37 to 6.2 pF.

TABLE 7-10. A13 REPLACEABLE PARTS (2147A & BELOW)

Reference Designation	HP Part Number	C D	Qty	Description	Mfr Code	Mfr Part Number
A12R6	2100-3056	8	1	RESISTOR-TRMR 5K 10% C SIDE-ADJ 17-TRN	02111	43P502
A12R7	2100-1757	2		RESISTOR-TRMR 500 5% WW SIDE-ADJ 1-TRN	28480	2100-1757
A12R8	0757-0288	1		RESISTOR 9.09K 1% .125W F TC=0+-100	19701	MF4C1/8-T0-9091-F
A12R9	0698-3457	6		RESISTOR 316K 1% .125W F TC=0+-100	28480	0698-3457
A12R10	0757-0346	2		RESISTOR 10 1% .125W F TC=0+-100	24546	C4-1/8-T0-10R0-F
A12R11	0757-0279	0		RESISTOR 3.16K 1% .125W F TC=0+-100	24546	C4-1/8-T0-3161-F
A12R12	0698-3444	1		RESISTOR 316 1% .125W F TC=0+-100	24546	C4-1/8-T0-316R-F
A12R13	0757-0288	1		RESISTOR 9.09K 1% .125W F TC=0+-100	19701	MF4C1/8-T0-9091-F
A12R14	0757-0395	1	5	RESISTOR 56.2 1% .125W F TC=0+-100	24546	C4-1/8-T0-56R2-F
A12R15	0757-0346	2		RESISTOR 10 1% .125W F TC=0+-100	24546	C4-1/8-T0-10R0-F
A12R16	0757-0346	2		RESISTOR 10 1% .125W F TC=0+-100	24546	C4-1/8-T0-10R0-F
A12R17	0757-0290	5		RESISTOR 6.19K 1% .125W F TC=0+-100	19701	MF4C1/8-T0-6191-F
A12R18	0757-0346	2		RESISTOR 10 1% .125W F TC=0+-100	24546	C4-1/8-T0-10R0-F
A12R19	0757-0290	5		RESISTOR 6.19K 1% .125W F TC=0+-100	19701	MF4C1/8-T0-6191-F
A12R20	0757-0279	0		RESISTOR 3.16K 1% .125W F TC=0+-100	24546	C4-1/8-T0-3161-F
A12R21	0698-3162	0		RESISTOR 46.4K 1% .125W F TC=0+-100	24546	C4-1/8-T0-4642-F
A12R22	0757-0279	0		RESISTOR 3.16K 1% .125W F TC=0+-100	24546	C4-1/8-T0-316R-F
A12R23	0698-3444	1		RESISTOR 316 1% .125W F TC=0+-100	24546	C4-1/8-T0-316R-F
A12R24	0757-0395	1		RESISTOR 56.2 1% .125W F TC=0+-100	24546	C4-1/8-T0-56R2-F
A12R25	0757-0280	3		RESISTOR 1K 1% .125W F TC=0+-100	24546	C4-1/8-T0-1001-F
A12R26	0757-0417	8	2	RESISTOR 562 1% .125W F TC=0+-100	24546	C4-1/8-T0-562R-F
A12R26	0757-0419	0		RESISTOR 681 1% .125W F TC=0+-100 (OPTION 001/002)	24546	C4-1/8-T0-681R-F
A12R27	0757-0280	3		RESISTOR 1K 1% .125W F TC=0+-100	24546	C4-1/8-T0-1001-F
A12R28	0757-0279	0		RESISTOR 3.16K 1% .125W F TC=0+-100	24546	C4-1/8-T0-3161-F
A12R29	0698-3444	1		RESISTOR 316 1% .125W F TC=0+-100	24546	C4-1/8-T0-316R-F
A12R30	0757-0395	1		RESISTOR 56.2 1% .125W F TC=0+-100	24546	C4-1/8-T0-56R2-F
A12R31	0757-0280	3		RESISTOR 1K 1% .125W F TC=0+-100	24546	C4-1/8-T0-1001-F
A12R32	0757-0420	3		RESISTOR 750 1% .125W F TC=0+-100	24546	C4-1/8-T0-751-F
A12R33	0757-0280	3		RESISTOR 1K 1% .125W F TC=0+-100	24546	C4-1/8-T0-1001-F
A12R34	0757-0279	0		RESISTOR 3.16K 1% .125W F TC=0+-100	24546	C4-1/8-T0-3161-F
A12R35	0698-3444	1		RESISTOR 316 1% .125W F TC=0+-100	24546	C4-1/8-T0-316R-F
A12R36	0757-0395	1		RESISTOR 56.2 1% .125W F TC=0+-100	24546	C4-1/8-T0-56R2-F
A12R37	0757-0280	3		RESISTOR 1K 1% .125W F TC=0+-100	24546	C4-1/8-T0-1001-F
A12R38	0757-0420	3		RESISTOR 750 1% .125W F TC=0+-100	24546	C4-1/8-T0-751-F
A12R39	0757-0280	3		RESISTOR 1K 1% .125W F TC=0+-100	24546	C4-1/8-T0-1001-F
A12R40	0698-3440	7		RESISTOR 196 1% .125W F TC=0+-100	24546	C4-1/8-T0-196R-F
A12R41	0757-0274	5		RESISTOR 1.21K 1% .125W F TC=0+-100	24546	C4-1/8-T0-1211-F
A12R42	0757-0274	5		RESISTOR 1.21K 1% .125W F TC=0+-100	24546	C4-1/8-T0-1211-F
A12R43	0698-3151	7		RESISTOR 2.87K 1% .125W F TC=0+-100	24546	C4-1/8-T0-2871-F
A12R44	0698-3151	7		RESISTOR 2.87K 1% .125W F TC=0+-100	24546	C4-1/8-T0-2871-F
A12R45	0757-0290	5		RESISTOR 6.19K 1% .125W F TC=0+-100	19701	MF4C1/8-T0-6191-F
A12R46	0698-3151	7		RESISTOR 2.87K 1% .125W F TC=0+-100	24546	C4-1/8-T0-2871-F
A12R47	0698-3162	0		RESISTOR 46.4K 1% .125W F TC=0+-100	24546	C4-1/8-T0-4642-F
A12R48	0698-3162	0		RESISTOR 46.4K 1% .125W F TC=0+-100	24546	C4-1/8-T0-4642-F
A12R49	0698-3162	0		RESISTOR 46.4K 1% .125W F TC=0+-100	24546	C4-1/8-T0-4642-F
A12S1	3101-0973	5	1	SWITCH-SL DPDT MINTR .5A 125VAC/DC PC	28480	3101-0973
A12TP1 THRU A12TP9	1251-0600	0		CONNECTOR-SGL CONT PIN 1.14-MM-BSC-SZ SQ	28480	1251-0600
A12VR1	1902-0033	4		DIODE-ZNR 1N823 6.2V 5% DO-7 PD=.4W	24046	1N823
A13	08558-60129	5	1	BANDWIDTH FILTER NO. 2	28480	08558-60129
A13C1	0160-2055	9		CAPACITOR-FXD .01UF +80-20% 100VDC CER	28480	0160-2055
A13C2	0160-0127	2		CAPACITOR-FXD 1UF +-20% 25VDC CER	28480	0160-0127
A13C3	0160-2236	8		CAPACITOR-FXD 1PF +- .25PF 500VDC CER	28480	0160-2236
A13C4	0160-2055	9		CAPACITOR-FXD .01UF +80-20% 100VDC CER	28480	0160-2055
A13C5	0160-2055	9		CAPACITOR-FXD .01UF +80-20% 100VDC CER	28480	0160-2055
A13C6	0160-2055	9		CAPACITOR-FXD .01UF +80-20% 100VDC CER	28480	0160-2055
A13C7	0160-2055	9		CAPACITOR-FXD .01UF +80-20% 100VDC CER	28480	0160-2055
A13C8	0160-2207	3		CAPACITOR-FXD 300PF +-5% 300VDC MICA	28480	0160-2207
A13C9	0160-2055	9		CAPACITOR-FXD .01UF +80-20% 100VDC CER	28480	0160-2055
A13C10	0160-2055	9		CAPACITOR-FXD .01UF +80-20% 100VDC CER	28480	0160-2055
A13C11	0160-2055	9		CAPACITOR-FXD .01UF +80-20% 100VDC CER	28480	0160-2055
A13C12	0160-2055	9		CAPACITOR-FXD .01UF +80-20% 100VDC CER	28480	0160-2055
A13C13	0160-3456	6		CAPACITOR-FXD 1000PF +-10% 1KVDC CER	28480	0160-3456
A13C14	0160-2250	6		CAPACITOR-FXD 5.1PF +- .25PF 500VDC CER	28480	0160-2250
A13C15	0121-0059	7		CAPACITOR-V TRMR-CER 2-8PF 350V PC-MTG	52763	304324 2/8PF NPO
A13C16				NOT ASSIGNED		
A13C17	0160-2055	9		CAPACITOR-FXD .01UF +80-20% 100VDC CER	28480	0160-2055
A13C18	0160-2055	9		CAPACITOR-FXD .01UF +80-20% 100VDC CER	28480	0160-2055
A13C19	0160-2055	9		CAPACITOR-FXD .01UF +80-20% 100VDC CER	28480	0160-2055
A13C20*	0140-0194	1		CAPACITOR-FXD 110PF +-5% 300VDC MICA	72136	DM15F111J0300WV1CR

See introduction to this section for ordering information
 *Indicates factory selected value

TABLE 7-10. A13 REPLACEABLE PARTS (2147A & BELOW)

Reference Designation	HP Part Number	C D	Qty	Description	Mfr Code	Mfr Part Number
A13C21	0160-3431	7		CAPACITOR-FXD 6.8PF +- .5PF 500VDC CER	28480	0160-3431
A13C22	0160-4084	8		CAPACITOR-FXD .1UF +-20% 50VDC CER	28480	0160-4084
A13C23	0121-0036	0		CAPACITOR-V TRMR-CER 5.5-18PF 350V	52763	304324 5.5/18PF NPO
A13C24				NOT ASSIGNED		
A13C25	0121-0446	6		CAPACITOR-V TRMR-CER 4.5-20PF 160V	28480	0121-0446
A13C26	0160-2055	9		CAPACITOR-FXD .01UF +80-20% 100VDC CER	28480	0160-2055
A13C27	0160-2055	9		CAPACITOR-FXD .01UF +80-20% 100VDC CER	28480	0160-2055
A13C28	0160-2055	9		CAPACITOR-FXD .01UF +80-20% 100VDC CER	28480	0160-2055
A13C29	0160-3456	6		CAPACITOR-FXD 1000PF +-10% 1KVDC CER	28480	0160-3456
A13C30	0160-2055	9		CAPACITOR-FXD .01UF +80-20% 100VDC CER	28480	0160-2055
A13C31	0160-3456	6		CAPACITOR-FXD 1000PF +-10% 1KVDC CER	28480	0160-3456
A13C32	0160-4084	8		CAPACITOR-FXD .1UF +-20% 50VDC CER	28480	0160-4084
A13C33	0160-2207	3		CAPACITOR-FXD 300PF +-5% 300VDC MICA	28480	0160-2207
A13C34	0160-2055	9		CAPACITOR-FXD .01UF +80-20% 100VDC CER	28480	0160-2055
A13C35	0160-2055	9		CAPACITOR-FXD .01UF +80-20% 100VDC CER	28480	0160-2055
A13C36	0160-2055	9		CAPACITOR-FXD .01UF +80-20% 100VDC CER	28480	0160-2055
A13C37	0160-2250	6		CAPACITOR-FXD 5.1PF +- .25PF 500VDC CER	28480	0160-2250
A13C38	0121-0059	7		CAPACITOR-V TRMR-CER 2-8PF 350V PC-MTG	52763	304324 2/8PF NPO
A13C39				NOT ASSIGNED		
A13C40	0160-2055	9		CAPACITOR-FXD .01UF +80-20% 100VDC CER	28480	0160-2055
A13C41	0160-3456	6		CAPACITOR-FXD 1000PF +-10% 1KVDC CER	28480	0160-3456
A13C42	0160-2055	9		CAPACITOR-FXD .01UF +80-20% 100VDC CER	28480	0160-2055
A13C43	0160-3431	7		CAPACITOR-FXD 6.8PF +- .5PF 500VDC CER	28480	0160-3431
A13C44*	0140-0194	1		CAPACITOR-FXD 110PF +-5% 300VDC MICA	72136	DM15F111J0300WV1CR
A13C45	0121-0036	0		CAPACITOR-V TRMR-CER 5.5-18PF 350V	52763	304324 5.5/18PF NPO
A13C46	0160-4084	8		CAPACITOR-FXD .1UF +-20% 50VDC CER	28480	0160-4084
A13C47	0160-2055	9		CAPACITOR-FXD .01UF +80-20% 100VDC CER	28480	0160-2055
A13C48	0160-2055	9		CAPACITOR-FXD .01UF +80-20% 100VDC CER	28480	0160-2055
A13C49	0160-2055	9		CAPACITOR-FXD .01UF +80-20% 100VDC CER	28480	0160-2055
A13C50	0160-2055	9		CAPACITOR-FXD .01UF +80-20% 100VDC CER	28480	0160-2055
A13C51	0160-2055	9		CAPACITOR-FXD .01UF +80-20% 100VDC CER	28480	0160-2055
A13C52	0160-2055	9		CAPACITOR-FXD .01UF +80-20% 100VDC CER	28480	0160-2055
A13C53	0160-2055	9		CAPACITOR-FXD .01UF +80-20% 100VDC CER	28480	0160-2055
A13C54	0121-0446	6		CAPACITOR-V TRMR-CER 4.5-20PF 160V	28480	0121-0446
A13C55	0160-2055	9		CAPACITOR-FXD .01UF +80-20% 100VDC CER	28480	0160-2055
A13C56 THRU				NOT ASSIGNED		
A13C59				NOT ASSIGNED		
A13C60	0160-2055	9		CAPACITOR-FXD .01UF +80-20% 100VDC CER	28480	0160-2055
A13C61	0160-2055	9		CAPACITOR-FXD .01UF +80-20% 100VDC CER	28480	0160-2055
A13C62	0160-2055	9		CAPACITOR-FXD .01UF +80-20% 100VDC CER	28480	0160-2055
A13C63	0160-2055	9		CAPACITOR-FXD .01UF +80-20% 100VDC CER	28480	0160-2055
A13C64	0160-2055	9		CAPACITOR-FXD .01UF +80-20% 100VDC CER	28480	0160-2055
A13C65	0160-2055	9		CAPACITOR-FXD .01UF +80-20% 100VDC CER	28480	0160-2055
A13C66	0160-2055	9		CAPACITOR-FXD .01UF +80-20% 100VDC CER	28480	0160-2055
A13C67	0160-2055	9		CAPACITOR-FXD .01UF +80-20% 100VDC CER	28480	0160-2055
A13C68 THRU				NOT ASSIGNED		
A13C72				NOT ASSIGNED		
A13C73	0121-0452	4		CAPACITOR-V TRMR-AIR 1.3-5.4PF 175V	74970	187-0103-028
A13C74	0121-0452	4		CAPACITOR-V TRMR-AIR 1.3-5.4PF 175V	74970	187-0103-028
A13CR1	1901-0047	8		DIODE-SWITCHING 20V 75MA 10NS	28480	1901-0047
A13CR2	1901-0047	8		DIODE-SWITCHING 20V 75MA 10NS	28480	1901-0047
A13CR3	1901-1070	9		DIODE-PIN 110V	28480	1901-1070
A13CR4	1901-1070	9		DIODE-PIN 110V	28480	1901-1070
A13CR5	1901-1070	9		DIODE-PIN 110V	28480	1901-1070
A13CR6	1901-0535	9		DIODE-SM SIG SCHOTTKY	28480	1901-0535
A13CR7				NOT ASSIGNED		
A13CR8	1901-0535	9		DIODE-SM SIG SCHOTTKY	28480	1901-0535
A13CR9	1901-0047	8		DIODE-SWITCHING 20V 75MA 10NS	28480	1901-0047
A13CR10	1901-0047	8		DIODE-SWITCHING 20V 75MA 10NS	28480	1901-0047
A13CR11	1901-1070	9		DIODE-PIN 110V	28480	1901-1070
A13CR12	1901-1070	9		DIODE-PIN 110V	28480	1901-1070
A13CR13	1901-0047	8		DIODE-SWITCHING 20V 75MA 10NS	28480	1901-0047
A13CR14	1901-0535	9		DIODE-SM SIG SCHOTTKY	28480	1901-0535
A13CR15	1901-0535	9		DIODE-SM SIG SCHOTTKY	28480	1901-0535
A13CR16	1901-0047	8		DIODE-SWITCHING 20V 75MA 10NS	28480	1901-0047
A13CR17	1901-0535	9		DIODE-SM SIG SCHOTTKY	28480	1901-0535
A13CR18	1901-0047	8		DIODE-SWITCHING 20V 75MA 10NS	28480	1901-0047
A13E1	9170-0029	3		CORE-SHIELDING BEAD	28480	9170-0029
A13E2	9170-0029	3		CORE-SHIELDING BEAD	28480	9170-0029
A13E3	9170-0029	3		CORE-SHIELDING BEAD	28480	9170-0029
A13E4	9170-0029	3		CORE-SHIELDING BEAD	28480	9170-0029
A13E5	9170-0029	3		CORE-SHIELDING BEAD	28480	9170-0029
A13E6	9170-0029	3		CORE-SHIELDING BEAD	28480	9170-0029
A13E7	9170-0029	3		CORE-SHIELDING BEAD	28480	9170-0029
A13E8	9170-0029	3		CORE-SHIELDING BEAD	28480	9170-0029

See introduction to this section for ordering information
 *Indicates factory selected value

TABLE 7-10. A13 REPLACEABLE PARTS (2147A & BELOW)

Reference Designation	HP Part Number	C D	Qty	Description	Mfr Code	Mfr Part Number
A13L1	9140-0112	2		INDUCTOR RF-CH-MLD 4.7UH 10%	28480	9140-0112
A13L2	9100-1641	0		INDUCTOR RF-CH-MLD 240UH 5% .166DX.385LG	28480	9100-1641
A13L3	9140-0114	4		INDUCTOR RF-CH-MLD 10UH 10% .166DX.385LG	28480	9140-0114
A13L4	9100-1624	9		INDUCTOR RF-CH-MLD 30UH 5% .166DX.385LG	28480	9100-1624
A13L5	9140-0179	1		INDUCTOR RF-CH-MLD 22UH 10% .166DX.385LG	28480	9140-0179
A13L6	9100-3854	1		INDUCTOR 400NH 10% .3DX1.016LG Q=150	28480	9100-3854
A13L7	9140-0098	3		INDUCTOR RF-CH-MLD 2.2UH 10%	28480	9140-0098
A13L8	9140-0178	0		INDUCTOR RF-CH-MLD 12UH 10% .166DX.385LG	28480	9140-0178
A13L9	9100-1641	0		INDUCTOR RF-CH-MLD 240UH 5% .166DX.385LG	28480	9100-1641
A13L10	9140-0114	4		INDUCTOR RF-CH-MLD 10UH 10% .166DX.385LG	28480	9140-0114
A13L11	9100-1624	9		INDUCTOR RF-CH-MLD 30UH 5% .166DX.385LG	28480	9100-1624
A13L12	9140-0179	1		INDUCTOR RF-CH-MLD 22UH 10% .166DX.385LG	28480	9140-0179
A13L13	9140-0098	3		INDUCTOR RF-CH-MLD 2.2UH 10%	28480	9140-0098
A13L14	9100-1620	5		INDUCTOR RF-CH-MLD 15UH 10% .166DX.385LG	28480	9100-1620
A13L15	9100-3854	1		INDUCTOR 400NH 10% .3DX1.016LG Q=150	28480	9100-3854
A13L16	9140-0144	0		INDUCTOR RF-CH-MLD 4.7UH 10% .105DX.26LG	28480	9140-0144
A13L17	9100-1624	9		INDUCTOR RF-CH-MLD 30UH 5% .166DX.385LG	28480	9100-1624
A13MP1	08565-00024	2		BAFFLE, INDUCTOR	28480	08565-00024
A13Q1	1854-0345	8		TRANSISTOR NPN 2N5179 SI TO-72 PD=200MW	04713	2N5179
A13Q2	1854-0404	0		TRANSISTOR NPN SI TO-18 PD=360MW	28480	1854-0404
A13Q3	1853-0007	7		TRANSISTOR PNP 2N3251 SI TO-18 PD=360MW	04713	2N3251
A13Q4	1853-0007	7		TRANSISTOR PNP 2N3251 SI TO-18 PD=360MW	04713	2N3251
A13Q5	1855-0267	5		TRANSISTOR J-FET N-CHAN D-MODE TO-92 SI	28480	1855-0267
A13Q6	1853-0007	7		TRANSISTOR PNP 2N3251 SI TO-18 PD=360MW	04713	2N3251
A13Q7	1854-0404	0		TRANSISTOR NPN SI TO-18 PD=360MW	28480	1854-0404
A13Q8	1853-0007	7		TRANSISTOR PNP 2N3251 SI TO-18 PD=360MW	04713	2N3251
A13Q9	1855-0267	5		TRANSISTOR J-FET N-CHAN D-MODE TO-92 SI	28480	1855-0267
A13Q10	1853-0007	7		TRANSISTOR PNP 2N3251 SI TO-18 PD=360MW	04713	2N3251
A13R1	0757-0447	4		RESISTOR 16.2K 1% .125W F TC=0+-100	24546	C4-1/8-T0-1622-F
A13R2	0698-3157	3	1	RESISTOR 19.6K 1% .125W F TC=0+-100	24546	C4-1/8-T0-1962-F
A13R3	0757-0402	1		RESISTOR 110 1% .125W F TC=0+-100	24546	C4-1/8-T0-111-F
A13R4				NOT ASSIGNED		
A13R5	0757-0405	4		RESISTOR 162 1% .125W F TC=0+-100	24546	C4-1/8-T0-162R-F
A13R6	0698-3431	6		RESISTOR 23.7 1% .125W F TC=0+-100	03888	PME55-1/8-T0-23R7-F
A13R7	0698-3427	0	1	RESISTOR 13.3 1% .125W F TC=0+-100	03888	PME55-1/8-T0-13R3-F
A13R8	0757-0402	1		RESISTOR 110 1% .125W F TC=0+-100	24546	C4-1/8-T0-111-F
A13R9	0757-0288	1		RESISTOR 9.09K 1% .125W F TC=0+-100	19701	MF4C1/8-T0-9091-F
A13R10	0698-0083	8		RESISTOR 1.96K 1% .125W F TC=0+-100	24546	C4-1/8-T0-1961-F
A13R11	0757-0442	9		RESISTOR 10K 1% .125W F TC=0+-100	24546	C4-1/8-T0-1002-F
A13R12	0757-0199	3		RESISTOR 21.5K 1% .125W F TC=0+-100	24546	C4-1/8-T0-2152-F
A13R13	0757-0416	7		RESISTOR 511 1% .125W F TC=0+-100	24546	C4-1/8-T0-511R-F
A13R14	0757-0346	2		RESISTOR 10 1% .125W F TC=0+-100	24546	C4-1/8-T0-10R0-F
A13R15	0698-3441	8		RESISTOR 215 1% .125W F TC=0+-100	24546	C4-1/8-T0-215R-F
A13R16	0757-0419	0		RESISTOR 681 1% .125W F TC=0+-100	24546	C4-1/8-T0-681R-F
A13R17	0698-3442	9		RESISTOR 237 1% .125W F TC=0+-100	24546	C4-1/8-T0-237R-F
A13R18	0757-0279	0		RESISTOR 3.16K 1% .125W F TC=0+-100	24546	C4-1/8-T0-3161-F
A13R19*	0757-0200	7		RESISTOR 5.62K 1% .125W F TC=0+-100	24546	C4-1/8-T0-5621-F
A13R20	0757-0442	9		RESISTOR 10K 1% .125W F TC=0+-100	24546	C4-1/8-T0-1002-F
A13R21	0757-0442	9		RESISTOR 10K 1% .125W F TC=0+-100	24546	C4-1/8-T0-1002-F
A13R22	0757-0442	9		RESISTOR 10K 1% .125W F TC=0+-100	24546	C4-1/8-T0-1002-F
A13R23*	0698-3156	2		RESISTOR 14.7K 1% .125W F TC=0+-100	24546	C4-1/8-T0-1472-F
A13R24	0757-0465	6		RESISTOR 100K 1% .125W F TC=0+-100	24546	C4-1/8-T0-1003-F
A13R25	0757-0465	6		RESISTOR 100K 1% .125W F TC=0+-100	24546	C4-1/8-T0-1003-F
A13R26	2100-3163	8		RESISTOR-TRMR 1M 20% C SIDE-ADJ 17-TRN	02111	43P105
A13R27	0757-0444	1		RESISTOR 12.1K 1% .125W F TC=0+-100	24546	C4-1/8-T0-1212-F
A13R28	0757-0290	5		RESISTOR 6.19K 1% .125W F TC=0+-100	19701	MF4C1/8-T0-6191-F
A13R29	0757-1094	9		RESISTOR 1.47K 1% .125W F TC=0+-100	24546	C4-1/8-T0-1471-F
A13R30	0757-0402	1		RESISTOR 110 1% .125W F TC=0+-100	24546	C4-1/8-T0-111-F
A13R31	2100-3052	4		RESISTOR-TRMR 50 10% C SIDE-ADJ 17-TRN	02111	43P500
A13R32				NOT ASSIGNED		
A13R33	0757-0442	9		RESISTOR 10K 1% .125W F TC=0+-100	24546	C4-1/8-T0-1002-F
A13R34	0757-0199	3		RESISTOR 21.5K 1% .125W F TC=0+-100	24546	C4-1/8-T0-2152-F
A13R35	0757-0288	1		RESISTOR 9.09K 1% .125W F TC=0+-100	19701	MF4C1/8-T0-9091-F
A13R36	0698-0083	8		RESISTOR 1.96K 1% .125W F TC=0+-100	24546	C4-1/8-T0-1961-F
A13R37	0757-0416	7		RESISTOR 511 1% .125W F TC=0+-100	24546	C4-1/8-T0-511R-F
A13R38	0698-3441	8		RESISTOR 215 1% .125W F TC=0+-100	24546	C4-1/8-T0-215R-F
A13R39	0757-0419	0		RESISTOR 681 1% .125W F TC=0+-100	24546	C4-1/8-T0-681R-F
A13R40	0698-3442	9		RESISTOR 237 1% .125W F TC=0+-100	24546	C4-1/8-T0-237R-F
A13R41	0757-0279	0		RESISTOR 3.16K 1% .125W F TC=0+-100	24546	C4-1/8-T0-3161-F
A13R42	0757-0442	9		RESISTOR 10K 1% .125W F TC=0+-100	24546	C4-1/8-T0-1002-F
A13R43*	0757-0438	3	4	RESISTOR 5.11K 1% .125W F TC=0+-100	24546	C4-1/8-T0-5111-F
A13R44	0757-0442	9		RESISTOR 10K 1% .125W F TC=0+-100	24546	C4-1/8-T0-1002-F
A13R45	0757-0401	0		RESISTOR 100 1% .125W F TC=0+-100	24546	C4-1/8-T0-101-F

See introduction to this section for ordering information
 *Indicates factory selected value

TABLE 7-10. A13 REPLACEABLE PARTS (2147A & BELOW)

Reference Designation	HP Part Number	C D	Qty	Description	Mfr Code	Mfr Part Number
A13R46	0757-0401	0		RESISTOR 100 1% .125W F TC=0+-100	24546	C4-1/8-T0-101-F
A13R47	0757-0346	2		RESISTOR 10 1% .125W F TC=0+-100	24546	C4-1/8-T0-10R0-F
A13R48*	0698-3156	2		RESISTOR 14.7K 1% .125W F TC=0+-100	24546	C4-1/8-T0-1472-F
A13R49	0757-0444	1		RESISTOR 12.1K 1% .125W F TC=0+-100	24546	C4-1/8-T0-1212-F
A13R50				NOT ASSIGNED		
A13R51	0757-0346	2		RESISTOR 10 1% .125W F TC=0+-100	24546	C4-1/8-T0-10R0-F
A13R52	0757-0290	5		RESISTOR 6.19K 1% .125W F TC=0+-100	19701	MF4C1/8-T0-6191-F
A13R53	0698-3440	7		RESISTOR 196 1% .125W F TC=0+-100	24546	C4-1/8-T0-196R-F
A13R54	0757-0416	7		RESISTOR 511 1% .125W F TC=0+-100	24546	C4-1/8-T0-511R-F
A13R55	0757-0442	9		RESISTOR 10K 1% .125W F TC=0+-100	24546	C4-1/8-T0-1002-F
A13R56*	0757-0274	5		RESISTOR 1.21K 1% .125W F TC=0+-100	24546	C4-1/8-T0-1211-F
A13R57	0757-0180	2		RESISTOR 31.6 1% .125W F TC=0+-100	28480	0757-0180
A13R58	0698-3153	2		RESISTOR 3.83K 1% .125W F TC=0+-100	24546	C4-1/8-T0-3831-F
A13R59	0757-0180	9		RESISTOR 31.6 1% .125W F TC=0+-100	28480	0757-0180
A13R60	0698-3153	9		RESISTOR 3.83K 1% .125W F TC=0+-100	24546	C4-1/8-T0-3831-F
A13TP1	0360-1788	7		CONNECTOR-SGL CONT PIN .045-IN-BSC-SZ SQ	28480	0360-1788
A13TP2	0360-1788	7		CONNECTOR-SGL CONT PIN .045-IN-BSC-SZ SQ	28480	0360-1788
A13TP3	1251-0600	0		CONNECTOR-SGL CONT PIN 1.14-MM-BSC-SZ SQ	28480	1251-0600
A13TP4	0360-1788	7		CONNECTOR-SGL CONT PIN .045-IN-BSC-SZ SQ	28480	0360-1788
A13TP5	0360-1788	7		CONNECTOR-SGL CONT PIN .045-IN-BSC-SZ SQ	28480	0360-1788
A13TP6	1251-0600	0		CONNECTOR-SGL CONT PIN 1.14-MM-BSC-SZ SQ	28480	1251-0600
A13TP7				NOT ASSIGNED		
A13TP8	1251-0600	0		CONNECTOR-SGL CONT PIN 1.14-MM-BSC-SZ SQ	28480	1251-0600
A13TP9	1251-0600	0		CONNECTOR-SGL CONT PIN 1.14-MM-BSC-SZ SQ	28480	1251-0600
A13TP10	1251-0600	0		CONNECTOR-SGL CONT PIN 1.14-MM-BSC-SZ SQ	28480	1251-0600
A13TP11	1251-0600	0		CONNECTOR-SGL CONT PIN 1.14-MM-BSC-SZ SQ	28480	1251-0600
A13VR1	1902-0048	1		DIODE-ZNR 6.81V 5% DO-35 PD=.4W	28480	1902-0048
A13Y1/2	0410-0450	5		CRYSTAL, 21.4 MHZ (MATCHED SET OF 4; INCL. A13Y1, A13Y2, A11Y1 AND A11Y2)	28480	0410-0450
A14	5061-5411	2	1	LOG AMPLIFIER ASSEMBLY	28480	5061-5411
A14C1	0160-4554	7	65	CAPACITOR-FXD .01UF +-20% 50VDC CER	28480	0160-4554
A14C2	0180-0197	8		CAPACITOR-FXD 2.2UF+-10% 20VDC TA	56289	150D225X9020A2
A14C3	0160-4554	7		CAPACITOR-FXD .01UF +-20% 50VDC CER	28480	0160-4554
A14C4	0160-4084	8		CAPACITOR-FXD .1UF +-20% 50VDC CER	28480	0160-4084
A14C5	0160-4084	8		CAPACITOR-FXD .1UF +-20% 50VDC CER	28480	0160-4084
A14C6	0160-4554	7		CAPACITOR-FXD .01UF +-20% 50VDC CER	28480	0160-4554
A14C7	0160-3879	7		CAPACITOR-FXD .01UF +-20% 100VDC CER	28480	0160-3879
A14C8	0160-4554	7		CAPACITOR-FXD .01UF +-20% 50VDC CER	28480	0160-4554
A14C9	0160-4554	7		CAPACITOR-FXD .01UF +-20% 50VDC CER	28480	0160-4554
A14C10	0160-4554	7		CAPACITOR-FXD .01UF +-20% 50VDC CER	28480	0160-4554
A14C11	0160-4554	7		CAPACITOR-FXD .01UF +-20% 50VDC CER	28480	0160-4554
A14C12	0160-4554	7		CAPACITOR-FXD .01UF +-20% 50VDC CER	28480	0160-4554
A14C13				NOT ASSIGNED		
A14C14 THRU A14C34	0160-4554	7		CAPACITOR-FXD .01UF +-20% 50VDC CER	28480	0160-4554
A14C35				NOT ASSIGNED		
A14C36 THRU A14C69	0160-4554	7		CAPACITOR-FXD .01UF +-20% 50VDC CER	28480	0160-4554
A14C70	0160-4519	4	1	CAPACITOR-FXD 9.1PF +-1.5PF 200VDC CER	28480	0160-4519
A14C71	0140-0195	2		CAPACITOR-FXD 130PF +-5% 300VDC MICA	72136	DM15F131J0300WV1CR
A14C72	0160-4386	3	1	CAPACITOR-FXD 33PF +-5% 200VDC CER 0+-30	28480	0160-4386
A14C73	0160-3872	0	1	CAPACITOR-FXD 2.2PF +-1.25PF 200VDC CER	28480	0160-3872
A14C74	0160-4554	7		CAPACITOR-FXD .01UF +-20% 50VDC CER	28480	0160-4554
A14C75	0160-4554	7		CAPACITOR-FXD .01UF +-20% 50VDC CER	28480	0160-4554
A14C76	0160-4554	7		CAPACITOR-FXD .01UF +-20% 50VDC CER	28480	0160-4554
A14C77	0160-4554	7		CAPACITOR-FXD .01UF +-20% 50VDC CER	28480	0160-4554
A14CR1	1901-0016	0	1	DIODE-GE 60V 60MA 1US DO-7	28480	1901-0016
A14CR2	1901-0050	3		DIODE-SWITCHING 80V 200MA 2NS DO-35	28480	1901-0050
A14CR3				NOT ASSIGNED		
A14CR4	1901-0050	3		DIODE-SWITCHING 80V 200MA 2NS DO-35	28480	1901-0050
A14CR5				NOT ASSIGNED		
A14CR6	1901-1085	6	16	DIODE-SM SIG SCHOTTKY	28480	1901-1085
A14CR7	1901-1085	6		DIODE-SM SIG SCHOTTKY	28480	1901-1085
A14CR8	1901-1085	6		DIODE-SM SIG SCHOTTKY	28480	1901-1085
A14CR9	1901-1085	6		DIODE-SM SIG SCHOTTKY	28480	1901-1085
A14CR10	1901-1085	6		DIODE-SM SIG SCHOTTKY	28480	1901-1085
A14CR11	1901-1085	6		DIODE-SM SIG SCHOTTKY	28480	1901-1085
A14CR12	1901-1070	9		DIODE-PIN 110V	28480	1901-1070
A14CR13	1901-1085	6		DIODE-SM SIG SCHOTTKY	28480	1901-1085
A14CR14	1901-1085	6	1	DIODE-SM SIG SCHOTTKY	28480	1901-1085
A14CR15	1901-1070	9		DIODE-PIN 110V	28480	1901-1070

See introduction to this section for ordering information
*Indicates factory selected value

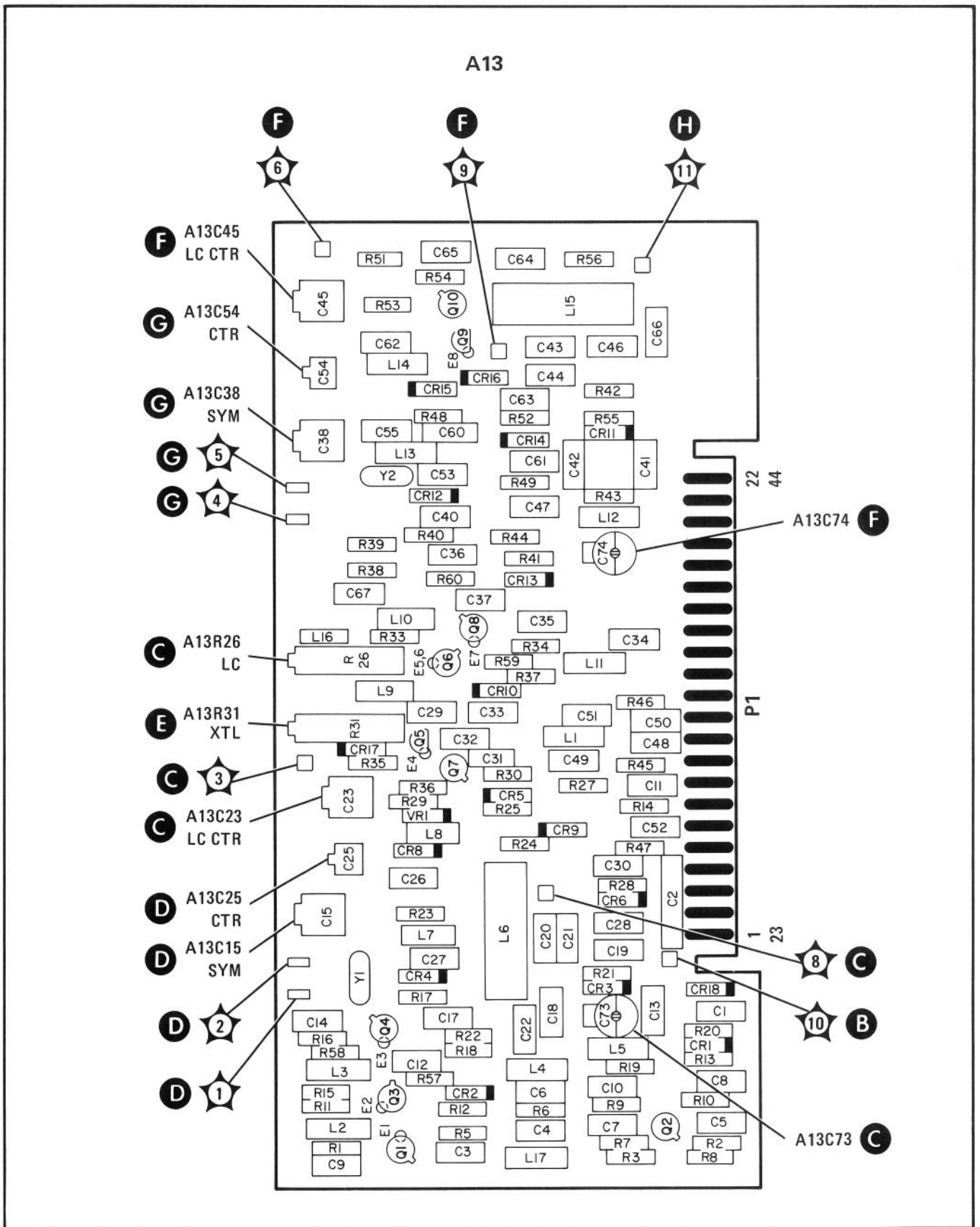

FIGURE 7-20. A13 BANDWIDTH FILTER NO. 2, COMPONENT LOCATIONS (2147A & BELOW)

NOTES

1. REFERENCE DESIGNATORS WITHIN THIS ASSEMBLY ARE ABBREVIATED, PREFIX ABBREVIATION WITH ASSEMBLY NUMBER FOR COMPLETE REFERENCE DESIGNATOR.
2. UNLESS OTHERWISE INDICATED: RESISTANCE IN OHMS (Ω) CAPACITANCE IN MICROFARADS (μ F) INDUCTANCE IN MICROHENRIES (μ H)
3. REFER TO FIGURE 8-2 FOR MEASUREMENT CONDITIONS.
4. TEMPERATURE COMPENSATING CAPACITOR.
5. ASTERISK (*) DENOTES FACTORY SELECTED COMPONENT. NOMINAL VALUE IS SHOWN.
6. SOURCE VOLTAGE SHOULD BE .2V TO 1.5V GREATER THAN THE GATE VOLTAGE.
7. VOLTAGES SHOULD BE MEASURED WITH 1 K Ω OR GREATER AT PROBE TIP TO PREVENT OSCILLATION AND ERRONEOUS READINGS.

BANDWIDTH	BW CON-TROL LINES TYPICAL VOLTAGES	BW6 XTAL	BW7 LC
3 MHz	+15	-4	+7
1 MHz	+15	-4	+9
300 kHz	+15	-4	+10
100 kHz	+15	-4	+14
30 kHz	-5	+10	+12
10 kHz	-5	+10	+14
3 kHz	-5	+9	+14
1 kHz	-5	+7	+15

9.  DESIGNATES SHIELDING BEAD.

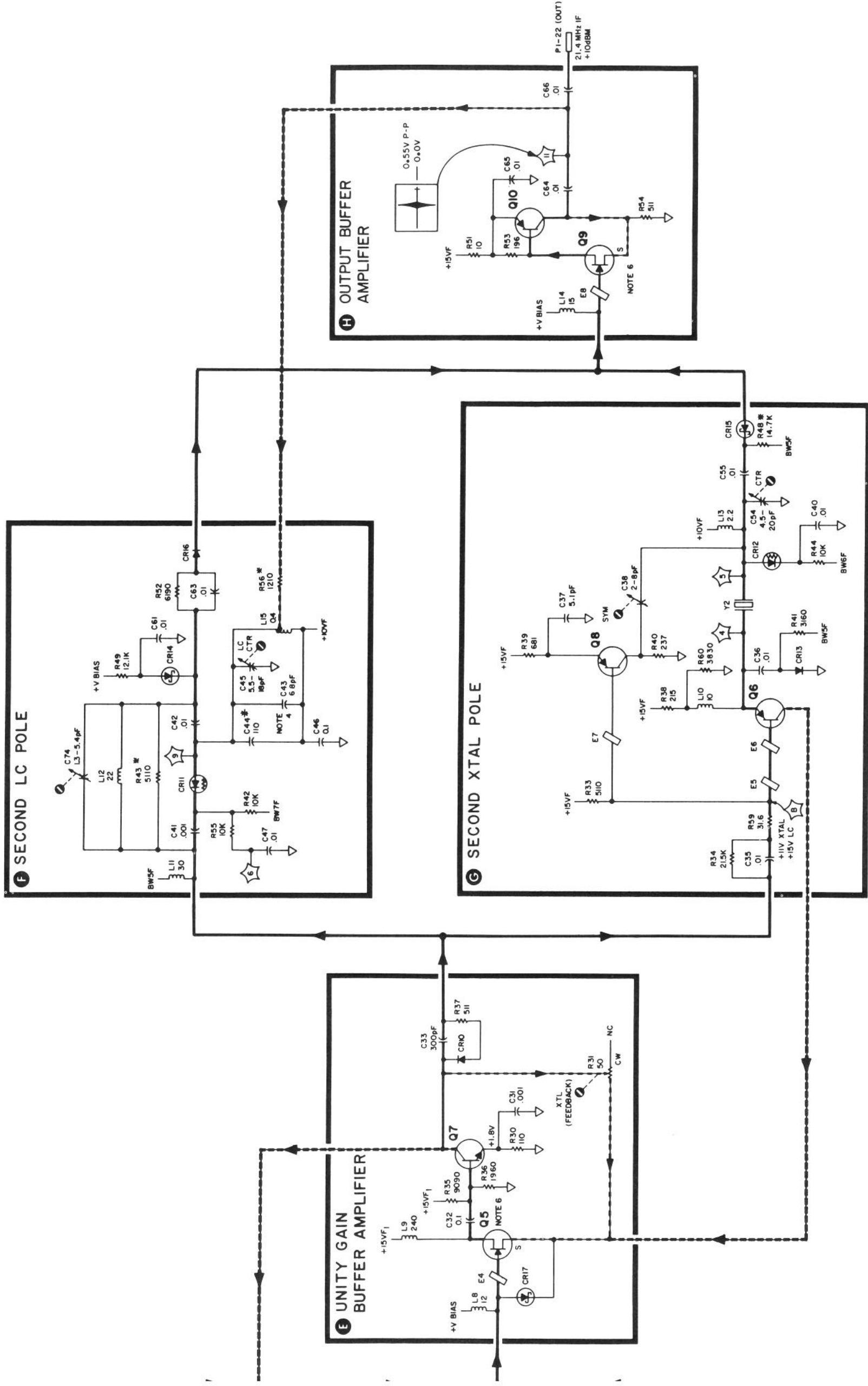
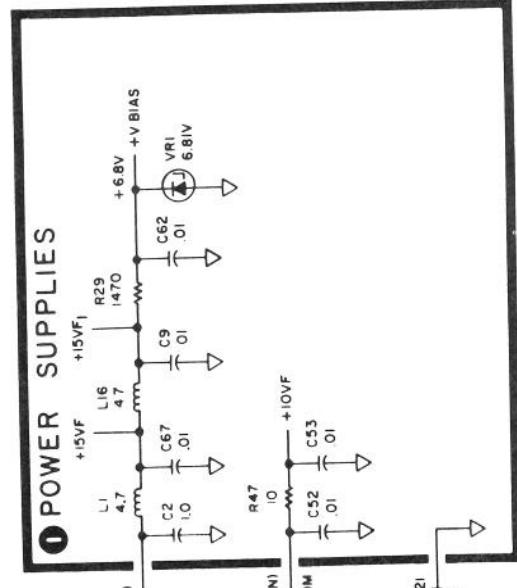
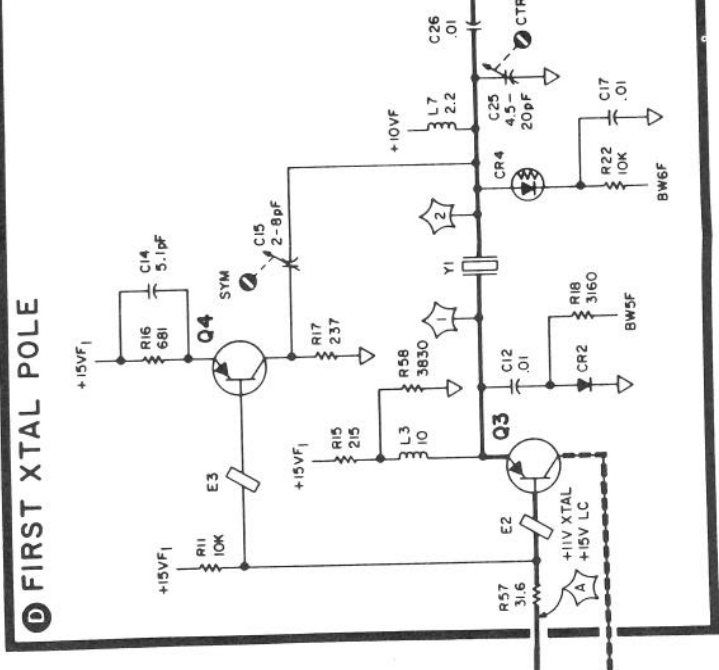
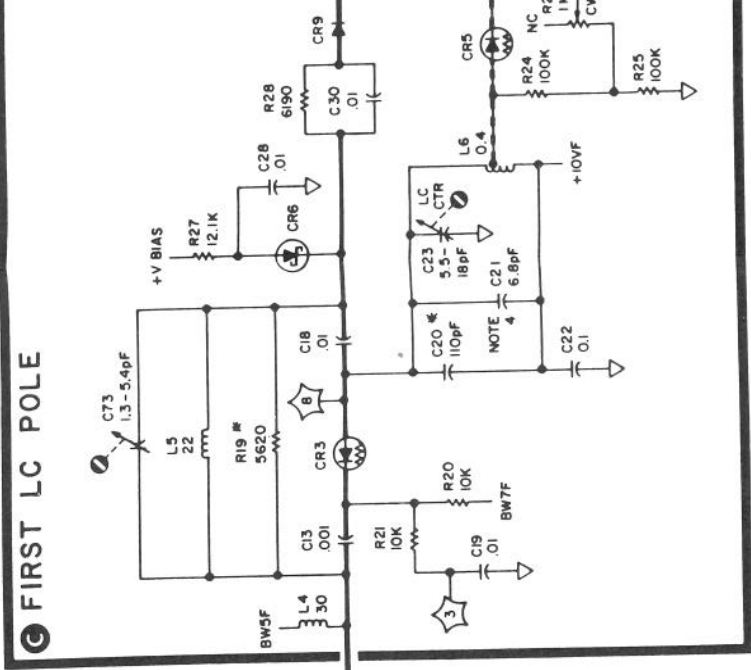
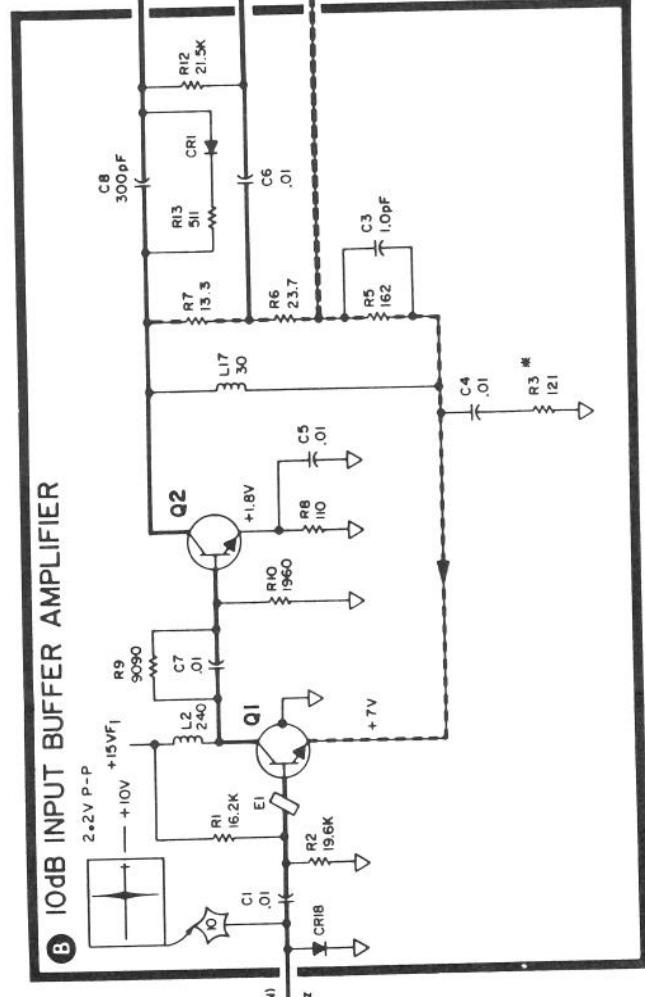
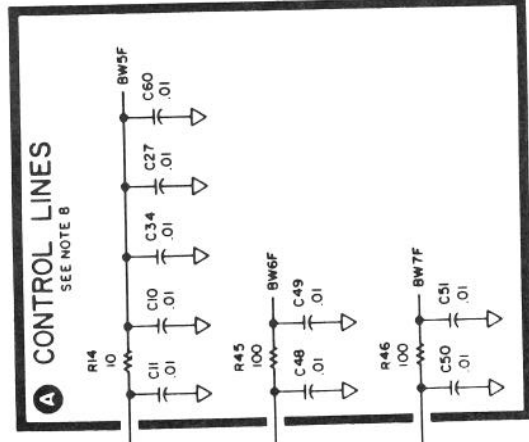

FIGURE 7-21. A13 BANDWIDTH FILTER NO. 2, SCHEMATIC DIAGRAM (2147A & BELOW)

A13 BANDWIDTH FILTER NO. 2

08558-60129

PIN	SIGNAL	TO/FROM	FUNCTION BLOCK
1	GND		1
23	21.4 MHz IF	A12P1.1	6
2	GND		1
24	NC		1
3	GND		1
25	NC		1
4	GND		1
26	NC		1
5	GND		1
27	+15V	P1.29	1
6	GND		1
28	NC		1
7	GND		1
29	+10V NOM	ASP1.29	1
8	GND		1
30	BW5	A2, ASP1.30	A
9	GND		1
31	BW6	ASP1.31	A
10	GND		1
32	BW7	ASP1.32	A
11	GND		1
33	NC		1
12	GND		1
34	NC		1
13	GND		1
35	NC		1
14	GND		1
36	NC		1
15	GND		1
37	NC		1
16	GND		1
38	NC		1
17	GND		1
39	NC		1
18	GND		1
40	NC		1
19	GND		1
41	NC		1
20	GND		1
42	NC		1
21	GND		1
43	NC		1
22	21.4 MHz IF	A13P1.14, AUX C	H
44	NC		



PAGES 8-127 THROUGH 8-141/8-142: A14 LOG AMPLIFIER ASSEMBLY

- Table 8-14. A14 Log Amplifier, Replaceable Parts**
2142A & Below Replace Table 8-14 with Table 7-7 (2142A & BELOW) included in this Manual Backdating supplement.
- Figure 8-53. A14 Log Amplifier, Component Locations**
2142A & Below Replace Figure 8-53 with Figure 7-5 (2142A & BELOW) included in this Manual Backdating supplement.
- Figure 8-54. A14 Log Amplifier, Schematic Diagram (1 of 2) (2 of 2)**
2142A & Below Replace Figure 8-54 with Figure 7-6 (2142A & BELOW) included in this Manual Backdating supplement.

TABLE 7-7. A14 REPLACEABLE PARTS (2142A & BELOW)

Reference Designation	HP Part Number	C D	Qty	Description	Mfr Code	Mfr Part Number
A14	08565-60111	4	1	LOG AMPLIFIER	28480	08565-60111
A14C1	0160-2055	9	59	CAPACITOR-FXD .01UF +R0-20% 100VDC CER	28480	0160-2055
A14C2	0160-3459	9	7	CAPACITOR-FXD .02UF +-20% 100VDC CER	28480	0160-3459
A14C3	0160-3459	9		CAPACITOR-FXD .02UF +-20% 100VDC CER	28480	0160-3459
A14C4	0160-3459	9		CAPACITOR-FXD .02UF +-20% 100VDC CER	28480	0160-3459
A14C5	0160-3459	9		CAPACITOR-FXD .02UF +-20% 100VDC CER	28480	0160-3459
A14C6	0160-2055	9		CAPACITOR-FXD .01UF +R0-20% 100VDC CER	28480	0160-2055
A14C7	0160-3459	9		CAPACITOR-FXD .02UF +-20% 100VDC CER	28480	0160-3459
A14C8	0160-3459	9		CAPACITOR-FXD .02UF +-20% 100VDC CER	28480	0160-3459
A14C9	0160-2055	9		CAPACITOR-FXD .01UF +R0-20% 100VDC CER	28480	0160-2055
A14C10	0160-2055	9		CAPACITOR-FXD .01UF +R0-20% 100VDC CER	28480	0160-2055
A14C11	0160-2055	9		CAPACITOR-FXD .01UF +R0-20% 100VDC CER	28480	0160-2055
A14C12	0160-2055	9		CAPACITOR-FXD .01UF +R0-20% 100VDC CER	28480	0160-2055
A14C13	0160-2055	9		CAPACITOR-FXD .01UF +R0-20% 100VDC CER	28480	0160-2055
A14C14	0160-2055	9		CAPACITOR-FXD .01UF +R0-20% 100VDC CER	28480	0160-2055
A14C15	0160-2055	9		CAPACITOR-FXD .01UF +R0-20% 100VDC CER	28480	0160-2055
A14C16	0160-2055	9		CAPACITOR-FXD .01UF +R0-20% 100VDC CER	28480	0160-2055
A14C17	0160-2055	9		CAPACITOR-FXD .01UF +R0-20% 100VDC CER	28480	0160-2055
A14C18*	0160-2234	6	1	CAPACITOR-FXD .51PF +- .25PF 500VDC CER	28480	0160-2234
A14C19	0160-2055	9		CAPACITOR-FXD .01UF +R0-20% 100VDC CER	28480	0160-2055
A14C20	0160-2236	8	5	CAPACITOR-FXD 1PF +- .25PF 500VDC CER	28480	0160-2236
A14C21	0160-2055	9		CAPACITOR-FXD .01UF +R0-20% 100VDC CER	28480	0160-2055
A14C22	0160-2055	9		CAPACITOR-FXD .01UF +R0-20% 100VDC CER	28480	0160-2055
A14C23	0160-2055	9		CAPACITOR-FXD .01UF +R0-20% 100VDC CER	28480	0160-2055
A14C24	0160-2055	9		CAPACITOR-FXD .01UF +R0-20% 100VDC CER	28480	0160-2055
A14C25	0160-2055	9		CAPACITOR-FXD .01UF +R0-20% 100VDC CER	28480	0160-2055
A14C26	0160-2055	9		CAPACITOR-FXD .01UF +R0-20% 100VDC CER	28480	0160-2055
A14C27	0160-2055	9		CAPACITOR-FXD .01UF +R0-20% 100VDC CER	28480	0160-2055
A14C28*	0160-022A	6	1	CAPACITOR-FXD 22UF+-10% 15VDC TA	56289	150D226X9015B2
A14C29	0160-2055	9		CAPACITOR-FXD .01UF +R0-20% 100VDC CER	28480	0160-2055
A14C30*	0160-2236	8	5	CAPACITOR-FXD 1PF +- .25PF 500VDC CER	28480	0160-2236
A14C31	0160-2055	9		CAPACITOR-FXD .01UF +R0-20% 100VDC CER	28480	0160-2055
A14C32	0160-2055	9		CAPACITOR-FXD .01UF +R0-20% 100VDC CER	28480	0160-2055
A14C33	0160-2055	9		CAPACITOR-FXD .01UF +R0-20% 100VDC CER	28480	0160-2055
A14C34	0160-2055	9		CAPACITOR-FXD .01UF +R0-20% 100VDC CER	28480	0160-2055
A14C35	0160-2055	9		CAPACITOR-FXD .01UF +R0-20% 100VDC CER	28480	0160-2055
A14C36	0160-2055	9		CAPACITOR-FXD .01UF +R0-20% 100VDC CER	28480	0160-2055
A14C37	0160-2055	9		CAPACITOR-FXD .01UF +R0-20% 100VDC CER	28480	0160-2055
A14C38*	0160-2055	9		CAPACITOR-FXD .01UF +R0-20% 100VDC CER	28480	0160-2055
A14C39	0160-2055	9		CAPACITOR-FXD .01UF +R0-20% 100VDC CER	28480	0160-2055
A14C40*	0160-2236	8		CAPACITOR-FXD 1PF +- .25PF 500VDC CER	28480	0160-2236
A14C41	0160-2055	9		CAPACITOR-FXD .01UF +R0-20% 100VDC CER	28480	0160-2055
A14C42	0160-2055	9		CAPACITOR-FXD .01UF +R0-20% 100VDC CER	28480	0160-2055
A14C43	0160-2055	9		CAPACITOR-FXD .01UF +R0-20% 100VDC CER	28480	0160-2055
A14C44	0160-2055	9		CAPACITOR-FXD .01UF +R0-20% 100VDC CER	28480	0160-2055
A14C45				NOT ASSIGNED		
A14C46	0160-2055	9		CAPACITOR-FXD .01UF +R0-20% 100VDC CER	28480	0160-2055
A14C47	0160-2055	9		CAPACITOR-FXD .01UF +R0-20% 100VDC CER	28480	0160-2055
A14C48	0160-2055	9		CAPACITOR-FXD .01UF +R0-20% 100VDC CER	28480	0160-2055
A14C49	0160-2055	9		CAPACITOR-FXD .01UF +R0-20% 100VDC CER	28480	0160-2055
A14C50	0160-2055	9		CAPACITOR-FXD .01UF +R0-20% 100VDC CER	28480	0160-2055
A14C51	0160-3459	9		CAPACITOR-FXD .02UF +-20% 100VDC CER	28480	0160-3459
A14C52*	0160-2236	8		CAPACITOR-FXD 1PF +- .25PF 500VDC CER	28480	0160-2236
A14C53	0160-2055	9		CAPACITOR-FXD .01UF +R0-20% 100VDC CER	28480	0160-2055
A14C54	0160-2055	9		CAPACITOR-FXD .01UF +R0-20% 100VDC CER	28480	0160-2055
A14C55	0160-2055	9		CAPACITOR-FXD .01UF +R0-20% 100VDC CER	28480	0160-2055
A14C56	0160-2055	9		CAPACITOR-FXD .01UF +R0-20% 100VDC CER	28480	0160-2055
A14C57	0160-2236	2	1	CAPACITOR-FXD 9.1PF +- .25PF 500VDC CER	28480	0160-2236
A14C58	0160-2055	9		CAPACITOR-FXD .01UF +R0-20% 100VDC CER	28480	0160-2055
A14C59	0160-2055	9		CAPACITOR-FXD .01UF +R0-20% 100VDC CER	28480	0160-2055
A14C60	0160-2055	9		CAPACITOR-FXD .01UF +R0-20% 100VDC CER	28480	0160-2055
A14C61	0160-2055	9		CAPACITOR-FXD .01UF +R0-20% 100VDC CER	28480	0160-2055
A14C62	0140-0195	2	1	CAPACITOR-FXD 130PF +-5% 300VDC MICA	72136	DM15F131J0300WV1CR
A14C63	0160-2055	9		CAPACITOR-FXD .01UF +R0-20% 100VDC CER	28480	0160-2055
A14C64	0160-230A	5	1	CAPACITOR-FXD 36PF +-5% 300VDC MICA	28480	0160-2308
A14C65	0160-2240	4	1	CAPACITOR-FXD 2PF +- .25PF 500VDC CER	28480	0160-2240
A14C66	0160-2055	9		CAPACITOR-FXD .01UF +R0-20% 100VDC CER	28480	0160-2055
A14C67*	0160-2236	8		CAPACITOR-FXD 1PF +- .25PF 500VDC CER	28480	0160-2236
A14C68	0160-2055	9		CAPACITOR-FXD .01UF +R0-20% 100VDC CER	28480	0160-2055
A14C69	0160-2055	9		CAPACITOR-FXD .01UF +R0-20% 100VDC CER	28480	0160-2055
A14C70	0160-2055	9		CAPACITOR-FXD .01UF +R0-20% 100VDC CER	28480	0160-2055

See introduction to this section for ordering information
 *Indicates factory selected value

TABLE 7-7. A14 REPLACEABLE PARTS (2142A & BELOW)

Reference Designation	HP Part Number	C D	Qty	Description	Mfr Code	Mfr Part Number
A14C71	0160-2055	9		CAPACITOR-FXD .01UF +80-20% 100VDC CER	28480	0160-2055
A14C72	0160-2055	9		CAPACITOR-FXD .01UF +80-20% 100VDC CER	28480	0160-2055
A14C73	0160-2055	9		CAPACITOR-FXD .01UF +80-20% 100VDC CER	28480	0160-2055
A14C74	0180-2206	4	1	CAPACITOR-FXD 60UF+-10% 6VDC TA	56289	150D606X9006B2
A14C75	0160-2055	9		CAPACITOR-FXD .01UF +80-20% 100VDC CER	28480	0160-2055
A14C76	0160-2055	9		CAPACITOR-FXD .01UF +80-20% 100VDC CER	28480	0160-2055
A14C77	0160-2055	9		CAPACITOR-FXD .01UF +80-20% 100VDC CER	28480	0160-2055
A14C78	0180-0197	A	5	CAPACITOR-FXD 2.2UF+-10% 20VDC TA	56289	150D225X9020A2
A14CR1	1901-0040	1	17	DIODE-SWITCHING 30V 50MA 2NS DO-35	28480	1901-0040
A14CR2	1901-0040	1		DIODE-SWITCHING 30V 50MA 2NS DO-35	28480	1901-0040
A14CR3	1901-1085	6	17	DIODE-SCHOTTKY	28480	1901-1085
A14CR4	1901-1085	6		DIODE-SCHOTTKY	28480	1901-1085
A14CR5	1901-0040	1		DIODE-SWITCHING 30V 50MA 2NS DO-35	28480	1901-0040
A14CR6	1901-0040	1		DIODE-SWITCHING 30V 50MA 2NS DO-35	28480	1901-0040
A14CR7	1901-0040	1		DIODE-SWITCHING 30V 50MA 2NS DO-35	28480	1901-0040
A14CR8	1901-1085	6		DIODE-SCHOTTKY	28480	1901-1085
A14CR9	1901-1085	6		DIODE-SCHOTTKY	28480	1901-1085
A14CR10	1901-1085	6		DIODE-SCHOTTKY	28480	1901-1085
A14CR11	1901-1085	6		DIODE-SCHOTTKY	28480	1901-1085
A14CR12	1901-1085	6		DIODE-SCHOTTKY	28480	1901-1085
A14CR13	1901-1085	6		DIODE-SCHOTTKY	28480	1901-1085
A14CR14	1901-0047	8	3	DIODE-SWITCHING 20V 75MA 10NS	28480	1901-0047
A14CR15	1901-1085	6		DIODE-SCHOTTKY	28480	1901-1085
A14CR16	1901-1070	9	2	DIODE-PIN 110V	28480	1901-1070
A14CR17	1901-1085	6		DIODE-SCHOTTKY	28480	1901-1085
A14CR18	1901-1070	9		DIODE-PIN 110V	28480	1901-1070
A14CR19	1901-0040	1		DIODE-SWITCHING 30V 50MA 2NS DO-35	28480	1901-0040
A14CR20	1901-1085	6		DIODE-SCHOTTKY	28480	1901-1085
A14CR21	1901-1085	6		DIODE-SCHOTTKY	28480	1901-1085
A14CR22	1901-1085	6		DIODE-SCHOTTKY	28480	1901-1085
A14CR23	1901-1085	6		DIODE-SCHOTTKY	28480	1901-1085
A14CR24	1901-0040	1		DIODE-SWITCHING 30V 50MA 2NS DO-35	28480	1901-0040
A14CR25	1901-1085	6		DIODE-SCHOTTKY	28480	1901-1085
A14CR26	1901-0047	8		DIODE-SWITCHING 20V 75MA 10NS	28480	1901-0047
A14CR27	1901-1085	6		DIODE-SCHOTTKY	28480	1901-1085
A14CR28	1901-1085	6		DIODE-SCHOTTKY	28480	1901-1085
A14CR29	1901-0047	8		DIODE-SWITCHING 20V 75MA 10NS	28480	1901-0047
A14CR30	1901-0040	1		DIODE-SWITCHING 30V 50MA 2NS DO-35	28480	1901-0040
A14CR31	1901-0040	1		DIODE-SWITCHING 30V 50MA 2NS DO-35	28480	1901-0040
A14CR32	1901-0040	1		DIODE-SWITCHING 30V 50MA 2NS DO-35	28480	1901-0040
A14E1	9170-0029	3	1	CORE-SHIELDING READ	28480	9170-0029
A14L1	9100-1622	7	2	COIL-MLD 24UH 5% Q#60 .155DX.375LG-NOM	28480	9100-1622
A14L2	9140-0105	3	1	COIL-MLD 8.2UH 10% Q#50 .155DX.375LG-NOM	28480	9140-0105
A14L3	9100-1619	2	7	COIL-MLD 6.8UH 10% Q#50 .155DX.375LG-NOM	28480	9100-1619
A14L4	9100-1619	2		COIL-MLD 6.8UH 10% Q#50 .155DX.375LG-NOM	28480	9100-1619
A14L5	9100-1619	2		COIL-MLD 6.8UH 10% Q#50 .155DX.375LG-NOM	28480	9100-1619
A14L6	9100-1619	2		COIL-MLD 6.8UH 10% Q#50 .155DX.375LG-NOM	28480	9100-1619
A14L7	9100-1619	2		COIL-MLD 6.8UH 10% Q#50 .155DX.375LG-NOM	28480	9100-1619
A14L8	9100-1619	2		COIL-MLD 6.8UH 10% Q#50 .155DX.375LG-NOM	28480	9100-1619
A14L9	9100-1627	2	1	COIL-MLD 39UH 5% Q#60 .155DX.375LG-NOM	28480	9100-1627
A14L10	9100-1629	4	1	COIL-MLD 47UH 5% Q#55 .155DX.375LG-NOM	28480	9100-1629
A14L11	9100-1622	7		COIL-MLD 24UH 5% Q#60 .155DX.375LG-NOM	28480	9100-1622
A14L12	9100-1619	2		COIL-MLD 6.8UH 10% Q#50 .155DX.375LG-NOM	28480	9100-1619
A14L13	9140-0145	1	1	COIL-MLD 8.2UH 10% Q#60 .095DX.25LG-NOM	28480	9140-0145
A14L14	9100-2269	0	1	COIL-MLD 27UH 10% Q#45 .095DX.25LG-NOM	28480	9100-2269
A14Q1	1854-0071	7	3	TRANSISTOR NPN SI PD=300MW FT=200MHZ	28480	1854-0071
A14Q2	1854-0019	3	15	TRANSISTOR NPN SI TO-18 PD=360MW	28480	1854-0019
A14Q3	1854-0019	3		TRANSISTOR NPN SI TO-18 PD=360MW	28480	1854-0019
A14Q4	1854-0019	3		TRANSISTOR NPN SI TO-18 PD=360MW	28480	1854-0019
A14Q5	1854-0019	3		TRANSISTOR NPN SI TO-18 PD=360MW	28480	1854-0019
A14Q6	1854-0019	3		TRANSISTOR NPN SI TO-18 PD=360MW	28480	1854-0019
A14Q7	1854-0019	3		TRANSISTOR NPN SI TO-18 PD=360MW	28480	1854-0019
A14Q8	1854-0019	3		TRANSISTOR NPN SI TO-18 PD=360MW	28480	1854-0019
A14Q9	1854-0019	3		TRANSISTOR NPN SI TO-18 PD=360MW	28480	1854-0019
A14Q10	1854-0019	3		TRANSISTOR NPN SI TO-18 PD=360MW	28480	1854-0019
A14Q11	1854-0019	3		TRANSISTOR NPN SI TO-18 PD=360MW	28480	1854-0019
A14Q12	1854-0019	3		TRANSISTOR NPN SI TO-18 PD=360MW	28480	1854-0019
A14Q13	1854-0019	3		TRANSISTOR NPN SI TO-18 PD=360MW	28480	1854-0019
A14Q14	1854-0019	3		TRANSISTOR NPN SI TO-18 PD=360MW	28480	1854-0019
A14Q15	1854-0019	3		TRANSISTOR NPN SI TO-18 PD=360MW	28480	1854-0019
A14Q16	1853-0020	4	2	TRANSISTOR PNP SI PD=300MW FT=150MHZ	28480	1853-0020
A14Q17	1853-0007	7	4	TRANSISTOR PNP 2N3251 SI TO-18 PD=360MW	04713	2N3251
A14Q18	1854-0345	8	1	TRANSISTOR NPN 2N5179 SI TO-72 PD=200MW	04713	2N5179
A14Q19	1853-0015	7	1	TRANSISTOR PNP SI PD=200MW FT=500MHZ	28480	1853-0015
A14Q20	1854-0475	5	2	TRANSISTOR-DUAL NPN PD=750MW	28480	1854-0475

See introduction to this section for ordering information
 *Indicates factory selected value

TABLE 7-7. A14 REPLACEABLE PARTS (2142A & BELOW)

Reference Designation	HP Part Number	C D	Qty	Description	Mfr Code	Mfr Part Number
A14021	1A54-0404	0	6	TRANSISTOR NPN SI TO-18 PD=360MW	28480	1A54-0404
A14022	1A53-0020	4		TRANSISTOR PNP SI PD=300MW FT=150MHZ	28480	1A53-0020
A14023	1A54-0071	7		TRANSISTOR NPN SI PD=300MW FT=200MHZ	28480	1A54-0071
A14024	1A54-0071	7		TRANSISTOR NPN SI PD=300MW FT=200MHZ	28480	1A54-0071
A14025	1A54-0039	7	2	TRANSISTOR NPN PN3053S SI TO-39 PD=1W	01928	2N3053S
A14R1	2100-3109	2	2	RESISTOR-TRMR 2K 10% C SIDE-ADJ 17-TRN	02111	43P202
A14R2	2100-3161	6	1	RESISTOR-TRMR 20K 10% C SIDE-ADJ 17-TRN	02111	43P203
A14R3	2100-3109	2		RESISTOR-TRMR 2K 10% C SIDE-ADJ 17-TRN	02111	43P202
A14R4	0757-0442	9	9	RESISTOR 10K 1% .125W F TC=0+-100	24546	C4-1/8-T0=1002-F
A14R5	0757-0279	0		RESISTOR 3.16K 1% .125W F TC=0+-100	24546	C4-1/8-T0=3161-F
A14R6*	0757-0346	2	20	RESISTOR 10 1% .125W F TC=0+-100	24546	C4-1/8-T0=10R0-F
A14R7	0757-0442	9		RESISTOR 10K 1% .125W F TC=0+-100	24546	C4-1/8-T0=1002-F
A14R8*	0757-0280	3	9	RESISTOR 1K 1% .125W F TC=0+-100	24546	C4-1/8-T0=1001-F
A14R9	0757-0439	4	9	RESISTOR 6.81K 1% .125W F TC=0+-100	24546	C4-1/8-T0=6811-F
A14R10	0757-0465	6	4	RESISTOR 100K 1% .125W F TC=0+-100	24546	C4-1/8-T0=1003-F
A14R11	0757-0440	7	2	RESISTOR 7.5K 1% .125W F TC=0+-100	24546	C4-1/8-T0=7501-F
A14R12	0698-3157	3	2	RESISTOR 19.6K 1% .125W F TC=0+-100	24546	C4-1/8-T0=1962-F
A14R13	0698-3444	1	12	RESISTOR 316 1% .125W F TC=0+-100	24546	C4-1/8-T0=316R-F
A14R14	0757-0420	3	3	RESISTOR 750 1% .125W F TC=0+-100	24546	C4-1/8-T0=751-F
A14R15	0698-3136	8	1	RESISTOR 17.8K 1% .125W F TC=0+-100	24546	C4-1/8-T0=1782-F
A14R16*	0698-3443	0	1	RESISTOR 287 1% .125W F TC=0+-100	24546	C4-1/8-T0=287R-F
A14R17	0698-3156	2	5	RESISTOR 14.7K 1% .125W F TC=0+-100	24546	C4-1/8-T0=1472-F
A14R18				NOT ASSIGNED		
A14R19	0698-0085	0	2	RESISTOR 2.61K 1% .125W F TC=0+-100	24546	C4-1/8-T0=2611-F
A14R20	0757-0279	0		RESISTOR 3.16K 1% .125W F TC=0+-100	24546	C4-1/8-T0=3161-F
A14R21	0757-0289	2	12	RESISTOR 13.3K 1% .125W F TC=0+-100	19701	MF4C1/8-T0=1332-F
A14R22	0757-0346	2		RESISTOR 10 1% .125W F TC=0+-100	24546	C4-1/8-T0=10R0-F
A14R23	0698-3444	1		RESISTOR 316 1% .125W F TC=0+-100	24546	C4-1/8-T0=316R-F
A14R24	0757-0279	0		RESISTOR 3.16K 1% .125W F TC=0+-100	24546	C4-1/8-T0=3161-F
A14R25	0698-3444	1		RESISTOR 316 1% .125W F TC=0+-100	24546	C4-1/8-T0=316R-F
A14R26	0757-0290	5		RESISTOR 6.19K 1% .125W F TC=0+-100	19701	MF4C1/8-T0=6191-F
A14R27	0757-0346	2		RESISTOR 10 1% .125W F TC=0+-100	24546	C4-1/8-T0=10R0-F
A14R28	0698-3449	6	1	RESISTOR 28.7K 1% .125W F TC=0+-100	24546	C4-1/8-T0=2872-F
A14R29	0757-0199	3	7	RESISTOR 21.5K 1% .125W F TC=0+-100	24546	C4-1/8-T0=2152-F
A14R30	0698-3152	8	2	RESISTOR 3.48K 1% .125W F TC=0+-100	24546	C4-1/8-T0=3481-F
A14R31	0757-0279	0		RESISTOR 3.16K 1% .125W F TC=0+-100	24546	C4-1/8-T0=3161-F
A14R32	0757-0289	2		RESISTOR 13.3K 1% .125W F TC=0+-100	19701	MF4C1/8-T0=1332-F
A14R33	0757-0289	2		RESISTOR 13.3K 1% .125W F TC=0+-100	19701	MF4C1/8-T0=1332-F
A14R34	0698-3444	1		RESISTOR 316 1% .125W F TC=0+-100	24546	C4-1/8-T0=316R-F
A14R35*	0757-0346	2		RESISTOR 10 1% .125W F TC=0+-100	24546	C4-1/8-T0=10R0-F
A14R36	0698-3438	3	2	RESISTOR 147 1% .125W F TC=0+-100	24546	C4-1/8-T0=147R-F
A14R37	0757-0439	4		RESISTOR 6.81K 1% .125W F TC=0+-100	24546	C4-1/8-T0=6811-F
A14R38	0757-0279	0		RESISTOR 3.16K 1% .125W F TC=0+-100	24546	C4-1/8-T0=3161-F
A14R39	0698-3154	0	1	RESISTOR 4.22K 1% .125W F TC=0+-100	24546	C4-1/8-T0=4221-F
A14R40	0757-0280	3		RESISTOR 1K 1% .125W F TC=0+-100	24546	C4-1/8-T0=1001-F
A14R41	0757-0346	2		RESISTOR 10 1% .125W F TC=0+-100	24546	C4-1/8-T0=10R0-F
A14R42	0757-0346	2		RESISTOR 10 1% .125W F TC=0+-100	24546	C4-1/8-T0=10R0-F
A14R43	0757-0289	2		RESISTOR 13.3K 1% .125W F TC=0+-100	19701	MF4C1/8-T0=1332-F
A14R44				NOT ASSIGNED		
A14R45	0757-0439	4		RESISTOR 6.81K 1% .125W F TC=0+-100	24546	C4-1/8-T0=6811-F
A14R46*	0698-0083	8	2	RESISTOR 1.96K 1% .125W F TC=0+-100	24546	C4-1/8-T0=1961-F
A14R47	0757-0279	0		RESISTOR 3.16K 1% .125W F TC=0+-100	24546	C4-1/8-T0=3161-F
A14R48	0757-0289	2		RESISTOR 13.3K 1% .125W F TC=0+-100	19701	MF4C1/8-T0=1332-F
A14R49	0757-0416	7	5	RESISTOR 511 1% .125W F TC=0+-100	24546	C4-1/8-T0=511R-F
A14R50	0698-3444	1		RESISTOR 316 1% .125W F TC=0+-100	24546	C4-1/8-T0=316R-F
A14R51*	0757-0346	2		RESISTOR 10 1% .125W F TC=0+-100	24546	C4-1/8-T0=10R0-F
A14R52	0757-0465	6		RESISTOR 100K 1% .125W F TC=0+-100	24546	C4-1/8-T0=1003-F
A14R53	0698-0083	8		RESISTOR 1.96K 1% .125W F TC=0+-100	24546	C4-1/8-T0=1961-F
A14R54	0757-0280	3		RESISTOR 1K 1% .125W F TC=0+-100	24546	C4-1/8-T0=1001-F
A14R55	0698-3151	7		RESISTOR 2.87K 1% .125W F TC=0+-100	24546	C4-1/8-T0=2871-F
A14R56	0757-0458	7	1	RESISTOR 51.1K 1% .125W F TC=0+-100	24546	C4-1/8-T0=5112-F
A14R57	0757-0346	2		RESISTOR 10 1% .125W F TC=0+-100	24546	C4-1/8-T0=10R0-F
A14R58	0757-0289	2		RESISTOR 13.3K 1% .125W F TC=0+-100	19701	MF4C1/8-T0=1332-F
A14R59	0757-0442	9		RESISTOR 10K 1% .125W F TC=0+-100	24546	C4-1/8-T0=1002-F
A14R60	0698-3157	3		RESISTOR 19.6K 1% .125W F TC=0+-100	24546	C4-1/8-T0=1962-F
A14R61	0757-0442	9		RESISTOR 10K 1% .125W F TC=0+-100	24546	C4-1/8-T0=1002-F
A14R62	0698-3152	8		RESISTOR 3.48K 1% .125W F TC=0+-100	24546	C4-1/8-T0=3481-F
A14R63	0698-3159	5	1	RESISTOR 26.1K 1% .125W F TC=0+-100	24546	C4-1/8-T0=2612-F
A14R64*	0757-0279	0	14	RESISTOR 3.16K 1% .125W F TC=0+-100	24546	C4-1/8-T0=3161-F
A14R65	0757-0290	5		RESISTOR 6.19K 1% .125W F TC=0+-100	19701	MF4C1/8-T0=6191-F
A14R66	0757-0439	4		RESISTOR 6.81K 1% .125W F TC=0+-100	24546	C4-1/8-T0=6811-F
A14R67	0757-0279	0		RESISTOR 3.16K 1% .125W F TC=0+-100	24546	C4-1/8-T0=3161-F
A14R68	0757-0289	2		RESISTOR 13.3K 1% .125W F TC=0+-100	19701	MF4C1/8-T0=1332-F
A14R69	0757-0440	7		RESISTOR 7.5K 1% .125W F TC=0+-100	24546	C4-1/8-T0=7501-F
A14R70	0757-0463	4	1	RESISTOR 82.5K 1% .125W F TC=0+-100	24546	C4-1/8-T0=8252-F

See introduction to this section for ordering information
 *Indicates factory selected value

TABLE 7-7. A14 REPLACEABLE PARTS (2142A & BELOW)

Reference Designation	HP Part Number	C D	Qty	Description	Mfr Code	Mfr Part Number
A14R71	069A-3444	1		RESISTOR 316 1% .125W F TC=0+-100	24546	C4=1/8-T0-316R-F
A14R72	0757-0290	5		RESISTOR 6.19K 1% .125W F TC=0+-100	19701	MF4C1/8-T0-6191-F
A14R73*	0757-0346	2		RESISTOR 10 1% .125W F TC=0+-100	24546	C4=1/8-T0-10R0-F
A14R74*	069A-3151	7	2	RESISTOR 2.87K 1% .125W F TC=0+-100	24546	C4=1/8-T0-2871-F
A14R75	0757-0442	9		RESISTOR 10K 1% .125W F TC=0+-100	24546	C4=1/8-T0-1002-F
A14R76	0757-0289	2		RESISTOR 13.3K 1% .125W F TC=0+-100	19701	MF4C1/8-T0-1332-F
A14R77	0757-0280	3		RESISTOR 1K 1% .125W F TC=0+-100	24546	C4=1/8-T0-1001-F
A14R78	0757-0346	2		RESISTOR 10 1% .125W F TC=0+-100	24546	C4=1/8-T0-10R0-F
A14R79	0757-0346	2		RESISTOR 10 1% .125W F TC=0+-100	24546	C4=1/8-T0-10R0-F
A14R80	0757-0439	4		RESISTOR 6.81K 1% .125W F TC=0+-100	24546	C4=1/8-T0-6811-F
A14R81	0757-0403	2	1	RESISTOR 121 1% .125W F TC=0+-100	24546	C4=1/8-T0-121R-F
A14R82*	0757-0290	5	8	RESISTOR 6.19K 1% .125W F TC=0+-100	19701	MF4C1/8-T0-6191-F
A14R83	0757-0416	9	1	RESISTOR 619 1% .125W F TC=0+-100	24546	C4=1/8-T0-619R-F
A14R84	0757-0402	1	1	RESISTOR 119 1% .125W F TC=0+-100	24546	C4=1/8-T0-111-F
A14R85	0757-0279	0		RESISTOR 3.16K 1% .125W F TC=0+-100	24546	C4=1/8-T0-3161-F
A14R86				NOT ASSIGNED		
A14R87	0757-0289	2		RESISTOR 13.3K 1% .125W F TC=0+-100	19701	MF4C1/8-T0-1332-F
A14R88	0757-0416	7		RESISTOR 511 1% .125W F TC=0+-100	24546	C4=1/8-T0-511R-F
A14R89	0757-0346	2		RESISTOR 10 1% .125W F TC=0+-100	24546	C4=1/8-T0-10R0-F
A14R90	069A-3444	1		RESISTOR 316 1% .125W F TC=0+-100	24546	C4=1/8-T0-316R-F
A14R91	0757-0439	4		RESISTOR 6.81K 1% .125W F TC=0+-100	24546	C4=1/8-T0-6811-F
A14R92	0757-0346	2		RESISTOR 10 1% .125W F TC=0+-100	24546	C4=1/8-T0-10R0-F
A14R93	0757-0438	3	1	RESISTOR 5.11K 1% .125W F TC=0+-100	24546	C4=1/8-T0-5111-F
A14R94	0757-0346	2		RESISTOR 10 1% .125W F TC=0+-100	24546	C4=1/8-T0-10R0-F
A14R95	0757-0289	2		RESISTOR 13.3K 1% .125W F TC=0+-100	19701	MF4C1/8-T0-1332-F
A14R96	0757-0280	3		RESISTOR 1K 1% .125W F TC=0+-100	24546	C4=1/8-T0-1001-F
A14R97	0757-0346	2		RESISTOR 10 1% .125W F TC=0+-100	24546	C4=1/8-T0-10R0-F
A14R98	0757-0346	2		RESISTOR 10 1% .125W F TC=0+-100	24546	C4=1/8-T0-10R0-F
A14R99	0757-0346	2		RESISTOR 10 1% .125W F TC=0+-100	24546	C4=1/8-T0-10R0-F
A14R100	0757-0346	2		RESISTOR 10 1% .125W F TC=0+-100	24546	C4=1/8-T0-10R0-F
A14R101	0757-0439	4		RESISTOR 6.81K 1% .125W F TC=0+-100	24546	C4=1/8-T0-6811-F
A14R102*	0757-0290	5		RESISTOR 6.19K 1% .125W F TC=0+-100	19701	MF4C1/8-T0-6191-F
A14R103	0757-0405	4	1	RESISTOR 162 1% .125W F TC=0+-100	24546	C4=1/8-T0-162R-F
A14R104	0757-0279	0		RESISTOR 3.16K 1% .125W F TC=0+-100	24546	C4=1/8-T0-3161-F
A14R105	0757-0280	3		RESISTOR 1K 1% .125W F TC=0+-100	24546	C4=1/8-T0-1001-F
A14R106	0757-0289	2		RESISTOR 13.3K 1% .125W F TC=0+-100	19701	MF4C1/8-T0-1332-F
A14R107	0757-0288	1	1	RESISTOR 9.09K 1% .125W F TC=0+-100	19701	MF4C1/8-T0-9091-F
A14R108	069A-3444	1		RESISTOR 316 1% .125W F TC=0+-100	24546	C4=1/8-T0-316R-F
A14R109	0757-0439	4		RESISTOR 6.81K 1% .125W F TC=0+-100	24546	C4=1/8-T0-6811-F
A14R110	0757-0346	2		RESISTOR 10 1% .125W F TC=0+-100	24546	C4=1/8-T0-10R0-F
A14R111	069A-3158	4	1	RESISTOR 23.7K 1% .125W F TC=0+-100	24546	C4=1/8-T0-2372-F
A14R112	069A-3160	8	3	RESISTOR 31.6K 1% .125W F TC=0+-100	24546	C4=1/8-T0-3162-F
A14R113	069A-3160	8		RESISTOR 31.6K 1% .125W F TC=0+-100	24546	C4=1/8-T0-3162-F
A14R114	069A-3160	8		RESISTOR 31.6K 1% .125W F TC=0+-100	24546	C4=1/8-T0-3162-F
A14R115	0757-0346	2		RESISTOR 10 1% .125W F TC=0+-100	24546	C4=1/8-T0-10R0-F
A14R116	0757-0289	2		RESISTOR 13.3K 1% .125W F TC=0+-100	19701	MF4C1/8-T0-1332-F
A14R117	069A-0085	0		RESISTOR 2.61K 1% .125W F TC=0+-100	24546	C4=1/8-T0-2611-F
A14R118	0757-0439	4		RESISTOR 6.81K 1% .125W F TC=0+-100	24546	C4=1/8-T0-6811-F
A14R119*	0757-0290	5		RESISTOR 6.19K 1% .125W F TC=0+-100	19701	MF4C1/8-T0-6191-F
A14R120	0757-0279	0		RESISTOR 3.16K 1% .125W F TC=0+-100	24546	C4=1/8-T0-3161-F
A14R121	069A-3438	3		RESISTOR 147 1% .125W F TC=0+-100	24546	C4=1/8-T0-147R-F
A14R122	0757-0447	4	2	RESISTOR 16.2K 1% .125W F TC=0+-100	24546	C4=1/8-T0-1622-F
A14R123	0757-0447	4		RESISTOR 16.2K 1% .125W F TC=0+-100	24546	C4=1/8-T0-1622-F
A14R124	0757-0441	8	1	RESISTOR 8.25K 1% .125W F TC=0+-100	24546	C4=1/8-T0-8251-F
A14R125	069A-3260	9	2	RESISTOR 464K 1% .125W F TC=0+-100	28480	069A-3260
A14R126	0757-0442	9		RESISTOR 10K 1% .125W F TC=0+-100	24546	C4=1/8-T0-1002-F
A14R127	0757-0421	4	1	RESISTOR 825 1% .125W F TC=0+-100	24546	C4=1/8-T0-825R-F
A14R128	0757-0290	5		RESISTOR 6.19K 1% .125W F TC=0+-100	19701	MF4C1/8-T0-6191-F
A14R129	0757-0290	5		RESISTOR 6.19K 1% .125W F TC=0+-100	19701	MF4C1/8-T0-6191-F
A14R130*	0757-0467	8	1	RESISTOR 121K 1% .125W F TC=0+-100	24546	C4=1/8-T0-1213-F
A14U1	1826-0092	3	2	OP AMP GP DUAL T0-99	28480	1826-0092
A14VR1	1902-0041	4	1	DIODE=ZNR 5.11V 5% DO-7 PDS.4W TC=-.009%	28480	1902-0041
A14VR2	1902-0048	1	1	DIODE=ZNR 6.81V 5% DO-7 PDS.4W TC=-.043%	28480	1902-0048
A14VR3	1902-0579	3	1	DIODE=ZNR 5.11V 5% DO-15 PDS.1W TC=-.009%	28480	1902-0579

See introduction to this section for ordering information
 *Indicates factory selected value

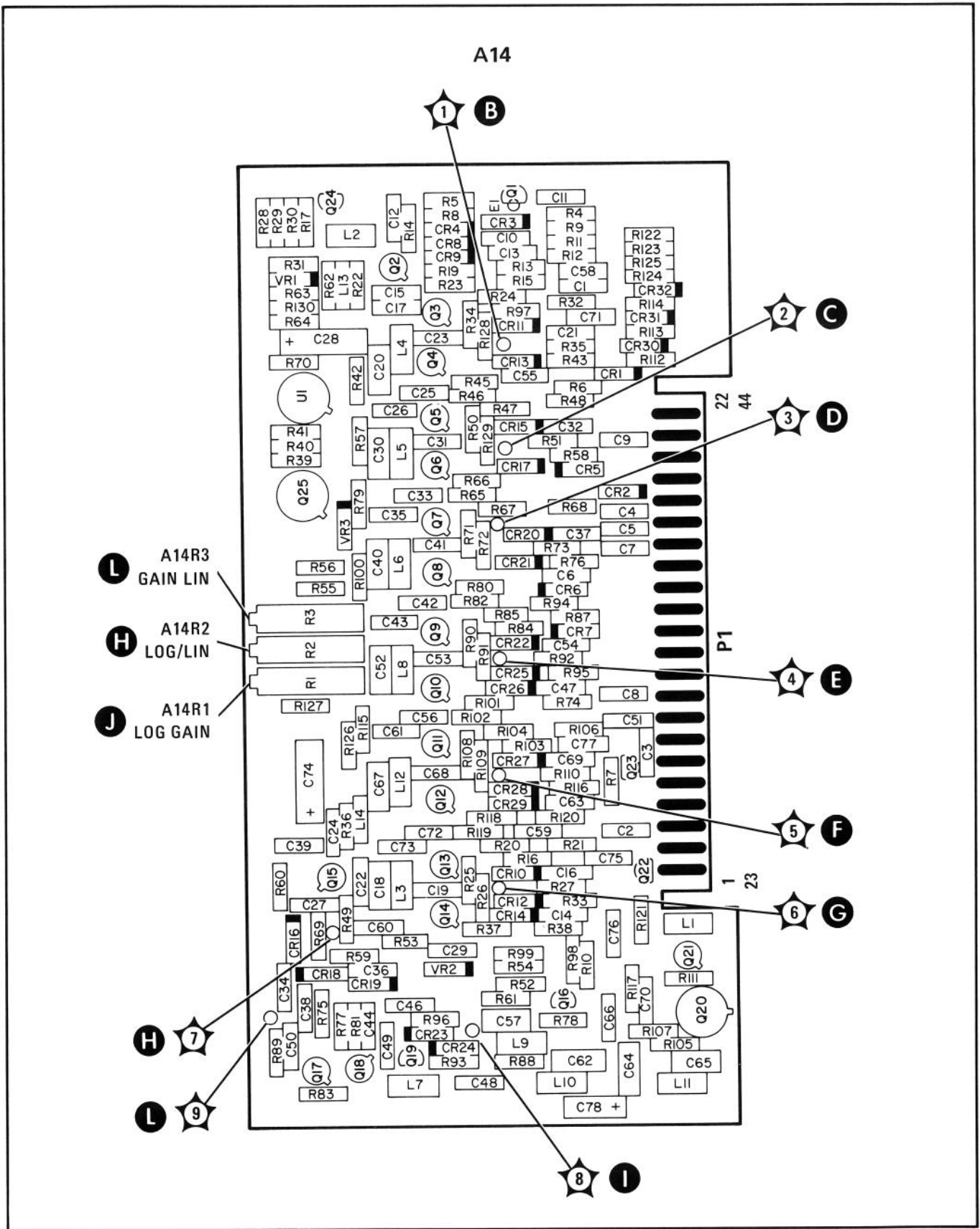

FIGURE 7-5. A14 LOG AMPLIFIER, COMPONENT AND TEST POINT LOCATIONS (2142A & BELOW)

PAGES 8-127 THROUGH 8-141/8-142: A14 LOG AMPLIFIER ASSEMBLY

- Table 8-14. A14 Log Amplifier, Replaceable Parts**
2142A & Below Replace Table 8-14 with Table 7-7 (2142A & BELOW) included in this Manual Backdating supplement.
- Figure 8-53. A14 Log Amplifier, Component Locations**
2142A & Below Replace Figure 8-53 with Figure 7-5 (2142A & BELOW) included in this Manual Backdating supplement.
- Figure 8-54. A14 Log Amplifier, Schematic Diagram (1 of 2) (2 of 2)**
2142A & Below Replace Figure 8-54 with Figure 7-6 (2142A & BELOW) included in this Manual Backdating supplement.

TABLE 7-7. A14 REPLACEABLE PARTS (2142A & BELOW)

Reference Designation	HP Part Number	C D	Qty	Description	Mfr Code	Mfr Part Number
A14	08565-60111	4	1	LOG AMPLIFIER	28480	08565-60111
A14C1	0160-2055	9	59	CAPACITOR-FXD .01UF +R0-20% 100VDC CER	28480	0160-2055
A14C2	0160-3459	9	7	CAPACITOR-FXD .02UF +-20% 100VDC CER	28480	0160-3459
A14C3	0160-3459	9		CAPACITOR-FXD .02UF +-20% 100VDC CER	28480	0160-3459
A14C4	0160-3459	9		CAPACITOR-FXD .02UF +-20% 100VDC CER	28480	0160-3459
A14C5	0160-3459	9		CAPACITOR-FXD .02UF +-20% 100VDC CER	28480	0160-3459
A14C6	0160-2055	9		CAPACITOR-FXD .01UF +R0-20% 100VDC CER	28480	0160-2055
A14C7	0160-3459	9		CAPACITOR-FXD .02UF +-20% 100VDC CER	28480	0160-3459
A14C8	0160-3459	9		CAPACITOR-FXD .02UF +-20% 100VDC CER	28480	0160-3459
A14C9	0160-2055	9		CAPACITOR-FXD .01UF +R0-20% 100VDC CER	28480	0160-2055
A14C10	0160-2055	9		CAPACITOR-FXD .01UF +R0-20% 100VDC CER	28480	0160-2055
A14C11	0160-2055	9		CAPACITOR-FXD .01UF +R0-20% 100VDC CER	28480	0160-2055
A14C12	0160-2055	9		CAPACITOR-FXD .01UF +R0-20% 100VDC CER	28480	0160-2055
A14C13	0160-2055	9		CAPACITOR-FXD .01UF +R0-20% 100VDC CER	28480	0160-2055
A14C14	0160-2055	9		CAPACITOR-FXD .01UF +R0-20% 100VDC CER	28480	0160-2055
A14C15	0160-2055	9		CAPACITOR-FXD .01UF +R0-20% 100VDC CER	28480	0160-2055
A14C16	0160-2055	9		CAPACITOR-FXD .01UF +R0-20% 100VDC CER	28480	0160-2055
A14C17	0160-2055	9		CAPACITOR-FXD .01UF +R0-20% 100VDC CER	28480	0160-2055
A14C18*	0160-2234	6	1	CAPACITOR-FXD .51PF +- .25PF 500VDC CER	28480	0160-2234
A14C19	0160-2055	9		CAPACITOR-FXD .01UF +R0-20% 100VDC CER	28480	0160-2055
A14C20	0160-2236	8	5	CAPACITOR-FXD 1PF +- .25PF 500VDC CER	28480	0160-2236
A14C21	0160-2055	9		CAPACITOR-FXD .01UF +R0-20% 100VDC CER	28480	0160-2055
A14C22	0160-2055	9		CAPACITOR-FXD .01UF +R0-20% 100VDC CER	28480	0160-2055
A14C23	0160-2055	9		CAPACITOR-FXD .01UF +R0-20% 100VDC CER	28480	0160-2055
A14C24	0160-2055	9		CAPACITOR-FXD .01UF +R0-20% 100VDC CER	28480	0160-2055
A14C25	0160-2055	9		CAPACITOR-FXD .01UF +R0-20% 100VDC CER	28480	0160-2055
A14C26	0160-2055	9		CAPACITOR-FXD .01UF +R0-20% 100VDC CER	28480	0160-2055
A14C27	0160-2055	9		CAPACITOR-FXD .01UF +R0-20% 100VDC CER	28480	0160-2055
A14C28*	0160-022A	6	1	CAPACITOR-FXD 22UF+-10% 15VDC TA	56289	150D226X9015B2
A14C29	0160-2055	9		CAPACITOR-FXD .01UF +R0-20% 100VDC CER	28480	0160-2055
A14C30*	0160-2236	8	5	CAPACITOR-FXD 1PF +- .25PF 500VDC CER	28480	0160-2236
A14C31	0160-2055	9		CAPACITOR-FXD .01UF +R0-20% 100VDC CER	28480	0160-2055
A14C32	0160-2055	9		CAPACITOR-FXD .01UF +R0-20% 100VDC CER	28480	0160-2055
A14C33	0160-2055	9		CAPACITOR-FXD .01UF +R0-20% 100VDC CER	28480	0160-2055
A14C34	0160-2055	9		CAPACITOR-FXD .01UF +R0-20% 100VDC CER	28480	0160-2055
A14C35	0160-2055	9		CAPACITOR-FXD .01UF +R0-20% 100VDC CER	28480	0160-2055
A14C36	0160-2055	9		CAPACITOR-FXD .01UF +R0-20% 100VDC CER	28480	0160-2055
A14C37	0160-2055	9		CAPACITOR-FXD .01UF +R0-20% 100VDC CER	28480	0160-2055
A14C38*	0160-2055	9		CAPACITOR-FXD .01UF +R0-20% 100VDC CER	28480	0160-2055
A14C39	0160-2055	9		CAPACITOR-FXD .01UF +R0-20% 100VDC CER	28480	0160-2055
A14C40*	0160-2236	8		CAPACITOR-FXD 1PF +- .25PF 500VDC CER	28480	0160-2236
A14C41	0160-2055	9		CAPACITOR-FXD .01UF +R0-20% 100VDC CER	28480	0160-2055
A14C42	0160-2055	9		CAPACITOR-FXD .01UF +R0-20% 100VDC CER	28480	0160-2055
A14C43	0160-2055	9		CAPACITOR-FXD .01UF +R0-20% 100VDC CER	28480	0160-2055
A14C44	0160-2055	9		CAPACITOR-FXD .01UF +R0-20% 100VDC CER	28480	0160-2055
A14C45				NOT ASSIGNED		
A14C46	0160-2055	9		CAPACITOR-FXD .01UF +R0-20% 100VDC CER	28480	0160-2055
A14C47	0160-2055	9		CAPACITOR-FXD .01UF +R0-20% 100VDC CER	28480	0160-2055
A14C48	0160-2055	9		CAPACITOR-FXD .01UF +R0-20% 100VDC CER	28480	0160-2055
A14C49	0160-2055	9		CAPACITOR-FXD .01UF +R0-20% 100VDC CER	28480	0160-2055
A14C50	0160-2055	9		CAPACITOR-FXD .01UF +R0-20% 100VDC CER	28480	0160-2055
A14C51	0160-3459	9		CAPACITOR-FXD .02UF +-20% 100VDC CER	28480	0160-3459
A14C52*	0160-2236	8		CAPACITOR-FXD 1PF +- .25PF 500VDC CER	28480	0160-2236
A14C53	0160-2055	9		CAPACITOR-FXD .01UF +R0-20% 100VDC CER	28480	0160-2055
A14C54	0160-2055	9		CAPACITOR-FXD .01UF +R0-20% 100VDC CER	28480	0160-2055
A14C55	0160-2055	9		CAPACITOR-FXD .01UF +R0-20% 100VDC CER	28480	0160-2055
A14C56	0160-2055	9		CAPACITOR-FXD .01UF +R0-20% 100VDC CER	28480	0160-2055
A14C57	0160-2236	2	1	CAPACITOR-FXD 9.1PF +- .25PF 500VDC CER	28480	0160-2236
A14C58	0160-2055	9		CAPACITOR-FXD .01UF +R0-20% 100VDC CER	28480	0160-2055
A14C59	0160-2055	9		CAPACITOR-FXD .01UF +R0-20% 100VDC CER	28480	0160-2055
A14C60	0160-2055	9		CAPACITOR-FXD .01UF +R0-20% 100VDC CER	28480	0160-2055
A14C61	0160-2055	9		CAPACITOR-FXD .01UF +R0-20% 100VDC CER	28480	0160-2055
A14C62	0140-0195	2	1	CAPACITOR-FXD 130PF +-5% 300VDC MICA	72136	DM15F131J0300WV1CR
A14C63	0160-2055	9		CAPACITOR-FXD .01UF +R0-20% 100VDC CER	28480	0160-2055
A14C64	0160-230A	5	1	CAPACITOR-FXD 36PF +-5% 300VDC MICA	28480	0160-2308
A14C65	0160-2240	4	1	CAPACITOR-FXD 2PF +- .25PF 500VDC CER	28480	0160-2240
A14C66	0160-2055	9		CAPACITOR-FXD .01UF +R0-20% 100VDC CER	28480	0160-2055
A14C67*	0160-2236	8		CAPACITOR-FXD 1PF +- .25PF 500VDC CER	28480	0160-2236
A14C68	0160-2055	9		CAPACITOR-FXD .01UF +R0-20% 100VDC CER	28480	0160-2055
A14C69	0160-2055	9		CAPACITOR-FXD .01UF +R0-20% 100VDC CER	28480	0160-2055
A14C70	0160-2055	9		CAPACITOR-FXD .01UF +R0-20% 100VDC CER	28480	0160-2055

See introduction to this section for ordering information
 *Indicates factory selected value

TABLE 7-7. A14 REPLACEABLE PARTS (2142A & BELOW)

Reference Designation	HP Part Number	C D	Qty	Description	Mfr Code	Mfr Part Number	
A14C71	0160-2055	9	1	CAPACITOR-FXD .01UF +80-20% 100VDC CER	28480	0160-2055	
A14C72	0160-2055	9		CAPACITOR-FXD .01UF +80-20% 100VDC CER	28480	0160-2055	
A14C73	0160-2055	9		CAPACITOR-FXD .01UF +80-20% 100VDC CER	28480	0160-2055	
A14C74	0180-2206	4		CAPACITOR-FXD 60UF+-10% 6VDC TA	56289	150D606X9006B2	
A14C75	0160-2055	9		CAPACITOR-FXD .01UF +80-20% 100VDC CER	28480	0160-2055	
A14C76	0160-2055	9		CAPACITOR-FXD .01UF +80-20% 100VDC CER	28480	0160-2055	
A14C77	0160-2055	9		CAPACITOR-FXD .01UF +80-20% 100VDC CER	28480	0160-2055	
A14C78	0180-0197	A		5	CAPACITOR-FXD 2.2UF+-10% 20VDC TA	56289	150D225X9020A2
A14CR1	1901-0040	1	17	DIODE-SWITCHING 30V 50MA 2NS DO-35	28480	1901-0040	
A14CR2	1901-0040	1	17	DIODE-SWITCHING 30V 50MA 2NS DO-35	28480	1901-0040	
A14CR3	1901-1085	6		DIODE-SCHOTTKY	28480	1901-1085	
A14CR4	1901-1085	6		DIODE-SCHOTTKY	28480	1901-1085	
A14CR5	1901-0040	1		DIODE-SWITCHING 30V 50MA 2NS DO-35	28480	1901-0040	
A14CR6	1901-0040	1		DIODE-SWITCHING 30V 50MA 2NS DO-35	28480	1901-0040	
A14CR7	1901-0040	1	DIODE-SWITCHING 30V 50MA 2NS DO-35	28480	1901-0040		
A14CR8	1901-1085	6	DIODE-SCHOTTKY	28480	1901-1085		
A14CR9	1901-1085	6	DIODE-SCHOTTKY	28480	1901-1085		
A14CR10	1901-1085	6	DIODE-SCHOTTKY	28480	1901-1085		
A14CR11	1901-1085	6	DIODE-SCHOTTKY	28480	1901-1085		
A14CR12	1901-1085	6	DIODE-SCHOTTKY	28480	1901-1085		
A14CR13	1901-1085	6	DIODE-SCHOTTKY	28480	1901-1085		
A14CR14	1901-0047	8	3	DIODE-SWITCHING 20V 75MA 10NS	28480	1901-0047	
A14CR15	1901-1085	6		DIODE-SCHOTTKY	28480	1901-1085	
A14CR16	1901-1070	9	2	DIODE-PIN 110V	28480	1901-1070	
A14CR17	1901-1085	6		DIODE-SCHOTTKY	28480	1901-1085	
A14CR18	1901-1070	9	DIODE-PIN 110V	28480	1901-1070		
A14CR19	1901-0040	1	DIODE-SWITCHING 30V 50MA 2NS DO-35	28480	1901-0040		
A14CR20	1901-1085	6	DIODE-SCHOTTKY	28480	1901-1085		
A14CR21	1901-1085	6	DIODE-SCHOTTKY	28480	1901-1085		
A14CR22	1901-1085	6	DIODE-SCHOTTKY	28480	1901-1085		
A14CR23	1901-1085	6	DIODE-SCHOTTKY	28480	1901-1085		
A14CR24	1901-0040	1	DIODE-SWITCHING 30V 50MA 2NS DO-35	28480	1901-0040		
A14CR25	1901-1085	6	DIODE-SCHOTTKY	28480	1901-1085		
A14CR26	1901-0047	8	DIODE-SWITCHING 20V 75MA 10NS	28480	1901-0047		
A14CR27	1901-1085	6	DIODE-SCHOTTKY	28480	1901-1085		
A14CR28	1901-1085	6	DIODE-SCHOTTKY	28480	1901-1085		
A14CR29	1901-0047	8	DIODE-SWITCHING 20V 75MA 10NS	28480	1901-0047		
A14CR30	1901-0040	1	DIODE-SWITCHING 30V 50MA 2NS DO-35	28480	1901-0040		
A14CR31	1901-0040	1	DIODE-SWITCHING 30V 50MA 2NS DO-35	28480	1901-0040		
A14CR32	1901-0040	1	DIODE-SWITCHING 30V 50MA 2NS DO-35	28480	1901-0040		
A14E1	9170-0029	3	1	CORE-SHIELDING READ	28480	9170-0029	
A14L1	9100-1622	7	2	COIL-MLD 24UH 5% Q#60 .155DX.375LG-NOM	28480	9100-1622	
A14L7	9140-0105	3		1	COIL-MLD 8.2UH 10% Q#50 .155DX.375LG-NOM	28480	9140-0105
A14L3	9100-1619	2	7	COIL-MLD 6.8UH 10% Q#50 .155DX.375LG-NOM	28480	9100-1619	
A14L4	9100-1619	2		1	COIL-MLD 6.8UH 10% Q#50 .155DX.375LG-NOM	28480	9100-1619
A14L5	9100-1619	2	2	COIL-MLD 6.8UH 10% Q#50 .155DX.375LG-NOM	28480	9100-1619	
A14L6	9100-1619	2	2	COIL-MLD 6.8UH 10% Q#50 .155DX.375LG-NOM	28480	9100-1619	
A14L7	9100-1619	2	2	COIL-MLD 6.8UH 10% Q#50 .155DX.375LG-NOM	28480	9100-1619	
A14L8	9100-1619	2	2	COIL-MLD 6.8UH 10% Q#50 .155DX.375LG-NOM	28480	9100-1619	
A14L9	9100-1627	2	1	COIL-MLD 39UH 5% Q#60 .155DX.375LG-NOM	28480	9100-1627	
A14L10	9100-1629	4		1	COIL-MLD 47UH 5% Q#55 .155DX.375LG-NOM	28480	9100-1629
A14L11	9100-1622	7	2	COIL-MLD 24UH 5% Q#60 .155DX.375LG-NOM	28480	9100-1622	
A14L12	9100-1619	2	2	COIL-MLD 6.8UH 10% Q#50 .155DX.375LG-NOM	28480	9100-1619	
A14L13	9140-0145	1	1	COIL-MLD 8.2UH 10% Q#60 .095DX.25LG-NOM	28480	9140-0145	
A14L14	9100-2269	0	1	COIL-MLD 27UH 10% Q#45 .095DX.25LG-NOM	28480	9100-2269	
A14Q1	1854-0071	7	3	TRANSISTOR NPN SI PD=300MW FT=200MHZ	28480	1854-0071	
A14Q2	1854-0019	3		15	TRANSISTOR NPN SI TO-18 PD=360MW	28480	1854-0019
A14Q3	1854-0019	3		TRANSISTOR NPN SI TO-18 PD=360MW	28480	1854-0019	
A14Q4	1854-0019	3		TRANSISTOR NPN SI TO-18 PD=360MW	28480	1854-0019	
A14Q5	1854-0019	3		TRANSISTOR NPN SI TO-18 PD=360MW	28480	1854-0019	
A14Q6	1854-0019	3	TRANSISTOR NPN SI TO-18 PD=360MW	28480	1854-0019		
A14Q7	1854-0019	3	TRANSISTOR NPN SI TO-18 PD=360MW	28480	1854-0019		
A14Q8	1854-0019	3	TRANSISTOR NPN SI TO-18 PD=360MW	28480	1854-0019		
A14Q9	1854-0019	3	TRANSISTOR NPN SI TO-18 PD=360MW	28480	1854-0019		
A14Q10	1854-0019	3	TRANSISTOR NPN SI TO-18 PD=360MW	28480	1854-0019		
A14Q11	1854-0019	3	TRANSISTOR NPN SI TO-18 PD=360MW	28480	1854-0019		
A14Q12	1854-0019	3	TRANSISTOR NPN SI TO-18 PD=360MW	28480	1854-0019		
A14Q13	1854-0019	3	TRANSISTOR NPN SI TO-18 PD=360MW	28480	1854-0019		
A14Q14	1854-0019	3	TRANSISTOR NPN SI TO-18 PD=360MW	28480	1854-0019		
A14Q15	1854-0019	3	TRANSISTOR NPN SI TO-18 PD=360MW	28480	1854-0019		
A14Q16	1853-0020	4	2	TRANSISTOR PNP SI PD=300MW FT=150MHZ	28480	1853-0020	
A14Q17	1853-0007	7		4	TRANSISTOR PNP 2N3251 SI TO-18 PD=360MW	04713	2N3251
A14Q18	1854-0345	8	1	TRANSISTOR NPN 2N5179 SI TO-72 PD=200MW	04713	2N5179	
A14Q19	1853-0015	7	1	TRANSISTOR PNP SI PD=200MW FT=500MHZ	28480	1853-0015	
A14Q20	1854-0475	5	2	TRANSISTOR-DUAL NPN PD=750MW	28480	1854-0475	

See introduction to this section for ordering information
 *Indicates factory selected value

TABLE 7-7. A14 REPLACEABLE PARTS (2142A & BELOW)

Reference Designation	HP Part Number	C D	Qty	Description	Mfr Code	Mfr Part Number
A14021	1A54-0404	0	6	TRANSISTOR NPN SI TO-18 PD=360MW	28480	1A54-0404
A14022	1A53-0020	4		TRANSISTOR PNP SI PD=300MW FT=150MHZ	28480	1A53-0020
A14023	1A54-0071	7		TRANSISTOR NPN SI PD=300MW FT=200MHZ	28480	1A54-0071
A14024	1A54-0071	7		TRANSISTOR NPN SI PD=300MW FT=200MHZ	28480	1A54-0071
A14025	1A54-0039	7	2	TRANSISTOR NPN PN3053S SI TO-39 PD=1W	01928	2N3053S
A14R1	2100-3109	2	2	RESISTOR-TRMR 2K 10% C SIDE-ADJ 17-TRN	02111	43P202
A14R2	2100-3161	6	1	RESISTOR-TRMR 20K 10% C SIDE-ADJ 17-TRN	02111	43P203
A14R3	2100-3109	2		RESISTOR-TRMR 2K 10% C SIDE-ADJ 17-TRN	02111	43P202
A14R4	0757-0442	9	9	RESISTOR 10K 1% .125W F TC=0+-100	24546	C4-1/8-T0=1002-F
A14R5	0757-0279	0		RESISTOR 3.16K 1% .125W F TC=0+-100	24546	C4-1/8-T0=3161-F
A14R6*	0757-0346	2	20	RESISTOR 10 1% .125W F TC=0+-100	24546	C4-1/8-T0=10R0-F
A14R7	0757-0442	9		RESISTOR 10K 1% .125W F TC=0+-100	24546	C4-1/8-T0=1002-F
A14R8*	0757-0280	3	9	RESISTOR 1K 1% .125W F TC=0+-100	24546	C4-1/8-T0=1001-F
A14R9	0757-0439	4	9	RESISTOR 6.81K 1% .125W F TC=0+-100	24546	C4-1/8-T0=6811-F
A14R10	0757-0465	6	4	RESISTOR 100K 1% .125W F TC=0+-100	24546	C4-1/8-T0=1003-F
A14R11	0757-0440	7	2	RESISTOR 7.5K 1% .125W F TC=0+-100	24546	C4-1/8-T0=7501-F
A14R12	0698-3157	3	2	RESISTOR 19.6K 1% .125W F TC=0+-100	24546	C4-1/8-T0=1962-F
A14R13	0698-3444	1	12	RESISTOR 316 1% .125W F TC=0+-100	24546	C4-1/8-T0=316R-F
A14R14	0757-0420	3	3	RESISTOR 750 1% .125W F TC=0+-100	24546	C4-1/8-T0=751-F
A14R15	0698-3136	8	1	RESISTOR 17.8K 1% .125W F TC=0+-100	24546	C4-1/8-T0=1782-F
A14R16*	0698-3443	0	1	RESISTOR 287 1% .125W F TC=0+-100	24546	C4-1/8-T0=287R-F
A14R17	0698-3156	2	5	RESISTOR 14.7K 1% .125W F TC=0+-100	24546	C4-1/8-T0=1472-F
A14R18				NOT ASSIGNED		
A14R19	0698-0085	0	2	RESISTOR 2.61K 1% .125W F TC=0+-100	24546	C4-1/8-T0=2611-F
A14R20	0757-0279	0		RESISTOR 3.16K 1% .125W F TC=0+-100	24546	C4-1/8-T0=3161-F
A14R21	0757-0289	2	12	RESISTOR 13.3K 1% .125W F TC=0+-100	19701	MF4C1/8-T0=1332-F
A14R22	0757-0346	2		RESISTOR 10 1% .125W F TC=0+-100	24546	C4-1/8-T0=10R0-F
A14R23	0698-3444	1		RESISTOR 316 1% .125W F TC=0+-100	24546	C4-1/8-T0=316R-F
A14R24	0757-0279	0		RESISTOR 3.16K 1% .125W F TC=0+-100	24546	C4-1/8-T0=3161-F
A14R25	0698-3444	1		RESISTOR 316 1% .125W F TC=0+-100	24546	C4-1/8-T0=316R-F
A14R26	0757-0290	5		RESISTOR 6.19K 1% .125W F TC=0+-100	19701	MF4C1/8-T0=6191-F
A14R27	0757-0346	2		RESISTOR 10 1% .125W F TC=0+-100	24546	C4-1/8-T0=10R0-F
A14R28	0698-3449	6	1	RESISTOR 28.7K 1% .125W F TC=0+-100	24546	C4-1/8-T0=2872-F
A14R29	0757-0199	3	7	RESISTOR 21.5K 1% .125W F TC=0+-100	24546	C4-1/8-T0=2152-F
A14R30	0698-3152	8	2	RESISTOR 3.48K 1% .125W F TC=0+-100	24546	C4-1/8-T0=3481-F
A14R31	0757-0279	0		RESISTOR 3.16K 1% .125W F TC=0+-100	24546	C4-1/8-T0=3161-F
A14R32	0757-0289	2		RESISTOR 13.3K 1% .125W F TC=0+-100	19701	MF4C1/8-T0=1332-F
A14R33	0757-0289	2		RESISTOR 13.3K 1% .125W F TC=0+-100	19701	MF4C1/8-T0=1332-F
A14R34	0698-3444	1		RESISTOR 316 1% .125W F TC=0+-100	24546	C4-1/8-T0=316R-F
A14R35*	0757-0346	2		RESISTOR 10 1% .125W F TC=0+-100	24546	C4-1/8-T0=10R0-F
A14R36	0698-3438	3	2	RESISTOR 147 1% .125W F TC=0+-100	24546	C4-1/8-T0=147R-F
A14R37	0757-0439	4		RESISTOR 6.81K 1% .125W F TC=0+-100	24546	C4-1/8-T0=6811-F
A14R38	0757-0279	0		RESISTOR 3.16K 1% .125W F TC=0+-100	24546	C4-1/8-T0=3161-F
A14R39	0698-3154	0	1	RESISTOR 4.22K 1% .125W F TC=0+-100	24546	C4-1/8-T0=4221-F
A14R40	0757-0280	3		RESISTOR 1K 1% .125W F TC=0+-100	24546	C4-1/8-T0=1001-F
A14R41	0757-0346	2		RESISTOR 10 1% .125W F TC=0+-100	24546	C4-1/8-T0=10R0-F
A14R42	0757-0346	2		RESISTOR 10 1% .125W F TC=0+-100	24546	C4-1/8-T0=10R0-F
A14R43	0757-0289	2		RESISTOR 13.3K 1% .125W F TC=0+-100	19701	MF4C1/8-T0=1332-F
A14R44				NOT ASSIGNED		
A14R45	0757-0439	4		RESISTOR 6.81K 1% .125W F TC=0+-100	24546	C4-1/8-T0=6811-F
A14R46*	0698-0083	8	2	RESISTOR 1.96K 1% .125W F TC=0+-100	24546	C4-1/8-T0=1961-F
A14R47	0757-0279	0		RESISTOR 3.16K 1% .125W F TC=0+-100	24546	C4-1/8-T0=3161-F
A14R48	0757-0289	2		RESISTOR 13.3K 1% .125W F TC=0+-100	19701	MF4C1/8-T0=1332-F
A14R49	0757-0416	7	5	RESISTOR 511 1% .125W F TC=0+-100	24546	C4-1/8-T0=511R-F
A14R50	0698-3444	1		RESISTOR 316 1% .125W F TC=0+-100	24546	C4-1/8-T0=316R-F
A14R51*	0757-0346	2		RESISTOR 10 1% .125W F TC=0+-100	24546	C4-1/8-T0=10R0-F
A14R52	0757-0465	6		RESISTOR 100K 1% .125W F TC=0+-100	24546	C4-1/8-T0=1003-F
A14R53	0698-0083	8		RESISTOR 1.96K 1% .125W F TC=0+-100	24546	C4-1/8-T0=1961-F
A14R54	0757-0280	3		RESISTOR 1K 1% .125W F TC=0+-100	24546	C4-1/8-T0=1001-F
A14R55	0698-3151	7		RESISTOR 2.87K 1% .125W F TC=0+-100	24546	C4-1/8-T0=2871-F
A14R56	0757-0458	7	1	RESISTOR 51.1K 1% .125W F TC=0+-100	24546	C4-1/8-T0=5112-F
A14R57	0757-0346	2		RESISTOR 10 1% .125W F TC=0+-100	24546	C4-1/8-T0=10R0-F
A14R58	0757-0289	2		RESISTOR 13.3K 1% .125W F TC=0+-100	19701	MF4C1/8-T0=1332-F
A14R59	0757-0442	9		RESISTOR 10K 1% .125W F TC=0+-100	24546	C4-1/8-T0=1002-F
A14R60	0698-3157	3		RESISTOR 19.6K 1% .125W F TC=0+-100	24546	C4-1/8-T0=1962-F
A14R61	0757-0442	9		RESISTOR 10K 1% .125W F TC=0+-100	24546	C4-1/8-T0=1002-F
A14R62	0698-3152	8		RESISTOR 3.48K 1% .125W F TC=0+-100	24546	C4-1/8-T0=3481-F
A14R63	0698-3159	5	1	RESISTOR 26.1K 1% .125W F TC=0+-100	24546	C4-1/8-T0=2612-F
A14R64*	0757-0279	0	14	RESISTOR 3.16K 1% .125W F TC=0+-100	24546	C4-1/8-T0=3161-F
A14R65	0757-0290	5		RESISTOR 6.19K 1% .125W F TC=0+-100	19701	MF4C1/8-T0=6191-F
A14R66	0757-0439	4		RESISTOR 6.81K 1% .125W F TC=0+-100	24546	C4-1/8-T0=6811-F
A14R67	0757-0279	0		RESISTOR 3.16K 1% .125W F TC=0+-100	24546	C4-1/8-T0=3161-F
A14R68	0757-0289	2		RESISTOR 13.3K 1% .125W F TC=0+-100	19701	MF4C1/8-T0=1332-F
A14R69	0757-0440	7		RESISTOR 7.5K 1% .125W F TC=0+-100	24546	C4-1/8-T0=7501-F
A14R70	0757-0463	4	1	RESISTOR 82.5K 1% .125W F TC=0+-100	24546	C4-1/8-T0=8252-F

See introduction to this section for ordering information
 *Indicates factory selected value

TABLE 7-7. A14 REPLACEABLE PARTS (2142A & BELOW)

Reference Designation	HP Part Number	C D	Qty	Description	Mfr Code	Mfr Part Number
A14R71	069A-3444	1		RESISTOR 316 1% .125W F TC=0+-100	24546	C4=1/8-T0-316R-F
A14R72	0757-0290	5		RESISTOR 6.19K 1% .125W F TC=0+-100	19701	MF4C1/8-T0-6191-F
A14R73*	0757-0346	2		RESISTOR 10 1% .125W F TC=0+-100	24546	C4=1/8-T0-10R0-F
A14R74*	069A-3151	7	2	RESISTOR 2.87K 1% .125W F TC=0+-100	24546	C4=1/8-T0-2871-F
A14R75	0757-0442	9		RESISTOR 10K 1% .125W F TC=0+-100	24546	C4=1/8-T0-1002-F
A14R76	0757-0289	2		RESISTOR 13.3K 1% .125W F TC=0+-100	19701	MF4C1/8-T0-1332-F
A14R77	0757-0280	3		RESISTOR 1K 1% .125W F TC=0+-100	24546	C4=1/8-T0-1001-F
A14R78	0757-0346	2		RESISTOR 10 1% .125W F TC=0+-100	24546	C4=1/8-T0-10R0-F
A14R79	0757-0346	2		RESISTOR 10 1% .125W F TC=0+-100	24546	C4=1/8-T0-10R0-F
A14R80	0757-0439	4		RESISTOR 6.81K 1% .125W F TC=0+-100	24546	C4=1/8-T0-6811-F
A14R81	0757-0403	2	1	RESISTOR 121 1% .125W F TC=0+-100	24546	C4=1/8-T0-121R-F
A14R82*	0757-0290	5	8	RESISTOR 6.19K 1% .125W F TC=0+-100	19701	MF4C1/8-T0-6191-F
A14R83	0757-0416	9	1	RESISTOR 619 1% .125W F TC=0+-100	24546	C4=1/8-T0-619R-F
A14R84	0757-0402	1	1	RESISTOR 119 1% .125W F TC=0+-100	24546	C4=1/8-T0-111-F
A14R85	0757-0279	0		RESISTOR 3.16K 1% .125W F TC=0+-100	24546	C4=1/8-T0-3161-F
A14R86				NOT ASSIGNED		
A14R87	0757-0289	2		RESISTOR 13.3K 1% .125W F TC=0+-100	19701	MF4C1/8-T0-1332-F
A14R88	0757-0416	7		RESISTOR 511 1% .125W F TC=0+-100	24546	C4=1/8-T0-511R-F
A14R89	0757-0346	2		RESISTOR 10 1% .125W F TC=0+-100	24546	C4=1/8-T0-10R0-F
A14R90	069A-3444	1		RESISTOR 316 1% .125W F TC=0+-100	24546	C4=1/8-T0-316R-F
A14R91	0757-0439	4		RESISTOR 6.81K 1% .125W F TC=0+-100	24546	C4=1/8-T0-6811-F
A14R92	0757-0346	2		RESISTOR 10 1% .125W F TC=0+-100	24546	C4=1/8-T0-10R0-F
A14R93	0757-0438	3	1	RESISTOR 5.11K 1% .125W F TC=0+-100	24546	C4=1/8-T0-5111-F
A14R94	0757-0346	2		RESISTOR 10 1% .125W F TC=0+-100	24546	C4=1/8-T0-10R0-F
A14R95	0757-0289	2		RESISTOR 13.3K 1% .125W F TC=0+-100	19701	MF4C1/8-T0-1332-F
A14R96	0757-0280	3		RESISTOR 1K 1% .125W F TC=0+-100	24546	C4=1/8-T0-1001-F
A14R97	0757-0346	2		RESISTOR 10 1% .125W F TC=0+-100	24546	C4=1/8-T0-10R0-F
A14R98	0757-0346	2		RESISTOR 10 1% .125W F TC=0+-100	24546	C4=1/8-T0-10R0-F
A14R99	0757-0346	2		RESISTOR 10 1% .125W F TC=0+-100	24546	C4=1/8-T0-10R0-F
A14R100	0757-0346	2		RESISTOR 10 1% .125W F TC=0+-100	24546	C4=1/8-T0-10R0-F
A14R101	0757-0439	4		RESISTOR 6.81K 1% .125W F TC=0+-100	24546	C4=1/8-T0-6811-F
A14R102*	0757-0290	5		RESISTOR 6.19K 1% .125W F TC=0+-100	19701	MF4C1/8-T0-6191-F
A14R103	0757-0405	4	1	RESISTOR 162 1% .125W F TC=0+-100	24546	C4=1/8-T0-162R-F
A14R104	0757-0279	0		RESISTOR 3.16K 1% .125W F TC=0+-100	24546	C4=1/8-T0-3161-F
A14R105	0757-0280	3		RESISTOR 1K 1% .125W F TC=0+-100	24546	C4=1/8-T0-1001-F
A14R106	0757-0289	2		RESISTOR 13.3K 1% .125W F TC=0+-100	19701	MF4C1/8-T0-1332-F
A14R107	0757-0288	1	1	RESISTOR 9.09K 1% .125W F TC=0+-100	19701	MF4C1/8-T0-9091-F
A14R108	069A-3444	1		RESISTOR 316 1% .125W F TC=0+-100	24546	C4=1/8-T0-316R-F
A14R109	0757-0439	4		RESISTOR 6.81K 1% .125W F TC=0+-100	24546	C4=1/8-T0-6811-F
A14R110	0757-0346	2		RESISTOR 10 1% .125W F TC=0+-100	24546	C4=1/8-T0-10R0-F
A14R111	069A-3158	4	1	RESISTOR 23.7K 1% .125W F TC=0+-100	24546	C4=1/8-T0-2372-F
A14R112	069A-3160	8	3	RESISTOR 31.6K 1% .125W F TC=0+-100	24546	C4=1/8-T0-3162-F
A14R113	069A-3160	8		RESISTOR 31.6K 1% .125W F TC=0+-100	24546	C4=1/8-T0-3162-F
A14R114	069A-3160	8		RESISTOR 31.6K 1% .125W F TC=0+-100	24546	C4=1/8-T0-3162-F
A14R115	0757-0346	2		RESISTOR 10 1% .125W F TC=0+-100	24546	C4=1/8-T0-10R0-F
A14R116	0757-0289	2		RESISTOR 13.3K 1% .125W F TC=0+-100	19701	MF4C1/8-T0-1332-F
A14R117	069A-0085	0		RESISTOR 2.61K 1% .125W F TC=0+-100	24546	C4=1/8-T0-2611-F
A14R118	0757-0439	4		RESISTOR 6.81K 1% .125W F TC=0+-100	24546	C4=1/8-T0-6811-F
A14R119*	0757-0290	5		RESISTOR 6.19K 1% .125W F TC=0+-100	19701	MF4C1/8-T0-6191-F
A14R120	0757-0279	0		RESISTOR 3.16K 1% .125W F TC=0+-100	24546	C4=1/8-T0-3161-F
A14R121	069A-3438	3		RESISTOR 147 1% .125W F TC=0+-100	24546	C4=1/8-T0-147R-F
A14R122	0757-0447	4	2	RESISTOR 16.2K 1% .125W F TC=0+-100	24546	C4=1/8-T0-1622-F
A14R123	0757-0447	4		RESISTOR 16.2K 1% .125W F TC=0+-100	24546	C4=1/8-T0-1622-F
A14R124	0757-0441	8	1	RESISTOR 8.25K 1% .125W F TC=0+-100	24546	C4=1/8-T0-8251-F
A14R125	069A-3260	9	2	RESISTOR 464K 1% .125W F TC=0+-100	28480	069A-3260
A14R126	0757-0442	9		RESISTOR 10K 1% .125W F TC=0+-100	24546	C4=1/8-T0-1002-F
A14R127	0757-0421	4	1	RESISTOR 825 1% .125W F TC=0+-100	24546	C4=1/8-T0-825R-F
A14R128	0757-0290	5		RESISTOR 6.19K 1% .125W F TC=0+-100	19701	MF4C1/8-T0-6191-F
A14R129	0757-0290	5		RESISTOR 6.19K 1% .125W F TC=0+-100	19701	MF4C1/8-T0-6191-F
A14R130*	0757-0467	8	1	RESISTOR 121K 1% .125W F TC=0+-100	24546	C4=1/8-T0-1213-F
A14U1	1826-0092	3	2	OP AMP GP DUAL T0-99	28480	1826-0092
A14VR1	1902-0041	4	1	DIODE=ZNR 5.11V 5% DO-7 PDS,4W TC=-.009%	28480	1902-0041
A14VR2	1902-0048	1	1	DIODE=ZNR 6.81V 5% DO-7 PDS,4W TC=-.043%	28480	1902-0048
A14VR3	1902-0579	3	1	DIODE=ZNR 5.11V 5% DO-15 PDS,1W TC=-.009%	28480	1902-0579

See introduction to this section for ordering information
 *Indicates factory selected value

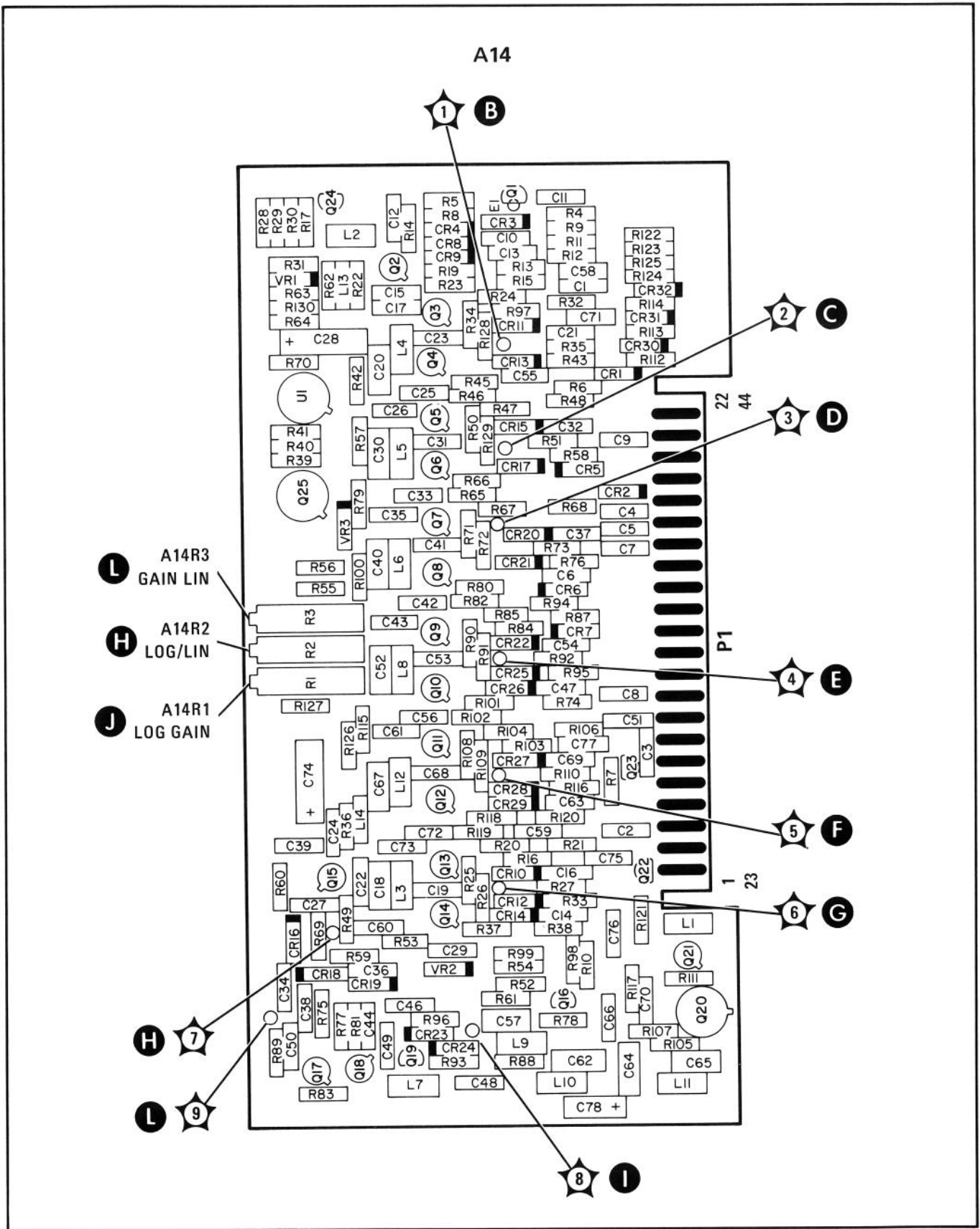
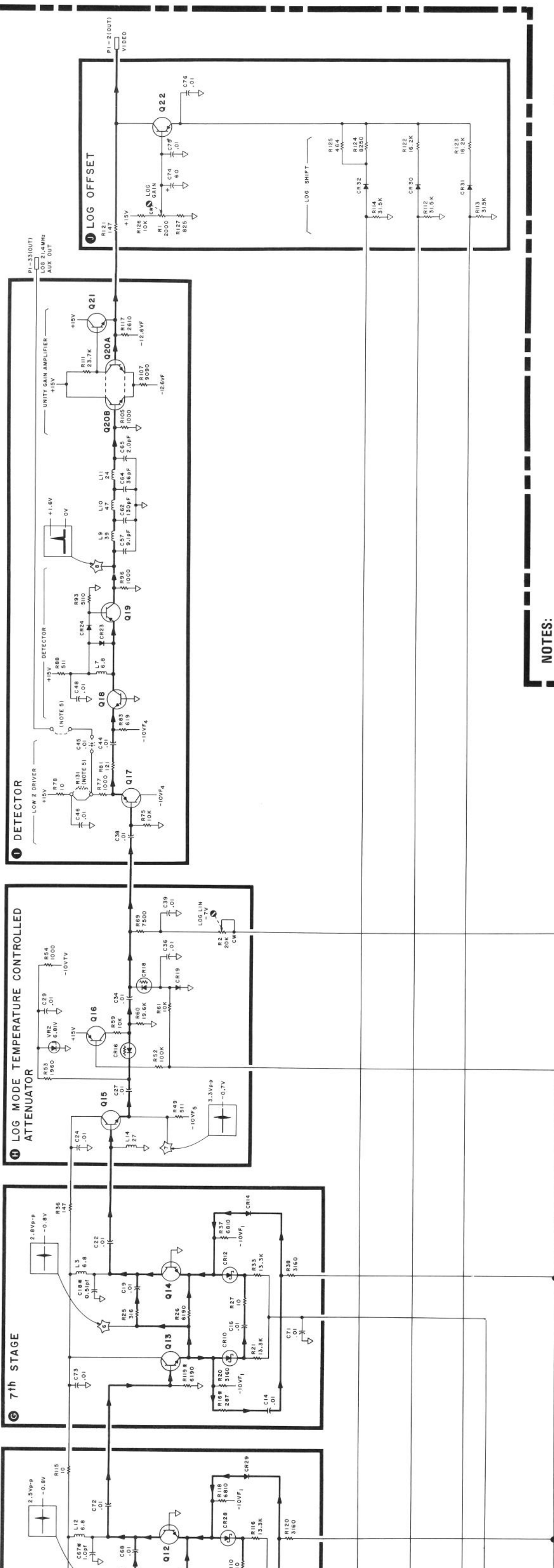

FIGURE 7-5. A14 LOG AMPLIFIER, COMPONENT AND TEST POINT LOCATIONS (2142A & BELOW)



NOTES:

1. REFERENCE DESIGNATORS WITHIN THIS ASSEMBLY ARE ABBREVIATED, PREFIX ABBREVIATION WITH ASSEMBLY NUMBER FOR COMPLETE REFERENCE DESIGNATOR.
2. UNLESS OTHERWISE INDICATED: RESISTANCE IN OHMS (Ω) CAPACITANCE IN MICROFARADS (μ F) INDUCTANCE IN MICROHENRIES (μ H)
3. ASTERISK (*) DENOTES FACTORY SELECTED COMPONENT. NOMINAL VALUE SHOWN.
4. REFER TO FIGURE 8-3 FOR MEASUREMENT CONDITIONS.
5. AUXILIARY LOG OUTPUT AS OPTION ONLY. C45, R131 AND JUMPER USED ONLY FOR OPTIONAL AUXILIARY LOG OUTPUT.
6. IC AND TRANSISTOR PIN CONFIGURATIONS (TOP VIEW):
 AI4Q20
 AI4UI

IF GAIN (dB)

REF LEVEL	INPUT ATTENUATION OPTIMUM INPUT dBm									
20m	30	20	10	0	10	20	30	40		
30	30	20	10	0	10	20	30	40		
40	30	20	10	0	10	20	30	40		
50	30	20	10	0	10	20	30	40		
60	30	20	10	0	10	20	30	40		
70	30	20	10	0	10	20	30	40		
80	30	20	10	0	10	20	30	40		
90	30	20	10	0	10	20	30	40		
100	30	20	10	0	10	20	30	40		

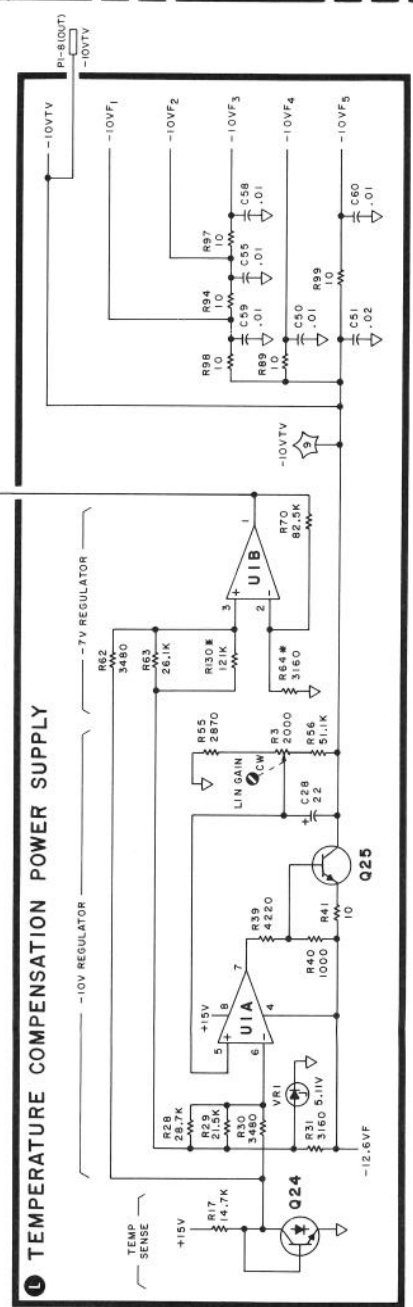

A14 LOG AMPLIFIER

08565-60111

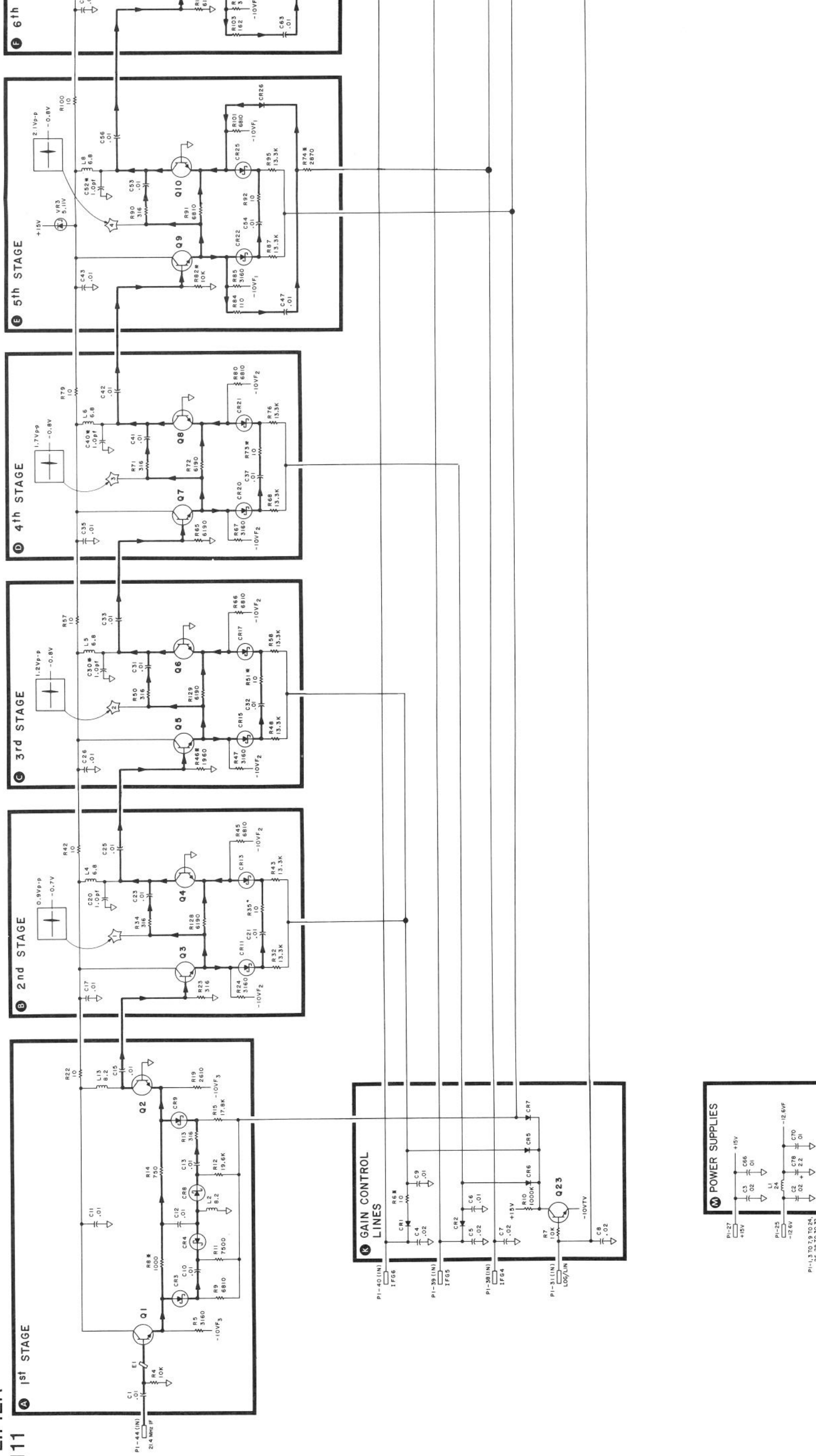

PIN	SIGNAL	TO/FROM	FUNCTION BLOCK
1	GND		M
23	VIDEO		J
24	GND	R6 VIDEO FILTER	M
3	-12.6V	P1-28	M
4	GND		M
26	GND		M
5	+15V	P1-29	M
6	GND		M
28	GND		M
7	GND		M
29	GND		M
8	-10V _{F1}	A2	L
30	GND		M
9	GND		M
31	LOG/LIN	A2	K
10	GND		M
32	GND		M
11	GND		M
33	LOG 21.4 MHz AUX. OUT	NC	L
12	GND		M
34	GND		M
13	GND		M
35	GND		M
14	GND		M
36	GND		M
15	GND		M
37	GND		M
16	GND		M
38	IFG4	A2	K
17	GND		M
39	IFG5	A2	K
18	GND		M
40	IFG6	A2	K
19	GND		M
41	GND		M
20	GND		M
42	GND		M
21	GND		M
43	GND		M
22	GND		M
44	21.4 MHz IF	A13P1-22	A

PAGES 8-153 THROUGH 8-157/8-158: A16 MOTHERBOARD ASSEMBLY**Table 8-16. A16 Motherboard, Replaceable Parts**

2245A & Below Change A16 to HP Part Number 08558-60174, Check Digit 0.

2215A & Below Change A16C8 to HP Part Number 0160-2055, Check Digit 9, CAPACITOR-FXD
.01UF +80-20% 100VDC CER.

2024A prefix
with suffixes
thru 06642,
& Below. Delete A16C9 and A16C10.

Figure 8-59. A16 Motherboard, Component Locations

2024A prefix
with suffixes
thru 06642,
& Below. Delete A16C9 and A16C10.

Figure 8-60. A16 Motherboard, Schematic Diagram (1 of 2)

2245A & Below Change A16 to HP Part Number 08558-60174.

2226A & Below Change A16 to HP Part Number 08558-60159.

2215A & Below Change A16C8 to .01 UFD.

2024A prefix
with suffixes
thru 06642,
& Below. Delete A16C9 and A16C10.

Figure 8-60. A16 Motherboard, Schematic Diagram (2 of 2)

2245A & Below Change A16 to HP Part Number 08558-60174.
Delete A16J2 +15V (and the 92 wire that runs off the motherboard to A2R2
Tuning) from lower-right corner of the schematic.

2226A & Below Change A16 to HP Part Number 08558-60159.
On XA8-35:
Change "GND" to read "GND 3".
Add a connection to XA7-31.
Delete the ground symbol.
On XA7-31:
Change "GND" to read "GND 3".
Add a connection to XA8-35.
Delete the ground symbol.
In the A16 Mnemonic table: change "GND" to "GND 3", with the description:
"Ground (from A7 Frequency Control)".

SECTION VIII SERVICE

8-1. INTRODUCTION

8-2. This section provides instructions for troubleshooting and repairing the HP Model 8558B Spectrum Analyzer. It includes circuit descriptions, general servicing hints and information, parts identification illustrations and lists, block diagrams, component locations diagrams, and schematics.

WARNING

To troubleshoot and repair this instrument, it must be removed from the display mainframe and reconnected through an extender cable. Operating the spectrum analyzer outside the mainframe in this manner exposes high voltage points in the instrument that will, if contacted, cause personal injury. Maintenance and repair of this instrument should, therefore, be performed only by a skilled person who knows the hazards involved. Where maintenance can be performed without power applied, the power should be removed. When any repair is completed, be sure that all safety features are intact and functioning and that all necessary parts are connected to their positive grounds.

8-3. SCHEMATIC SYMBOLS, TERMINOLOGY, AND VOLTAGE LEVELS

8-4. Symbols and terminology used on the schematic diagrams are explained in Figure 8-1. Test conditions for the signal and dc voltage levels shown on the block and schematic diagrams are provided in Figure 8-2.

8-5. TEST EQUIPMENT

8-6. Test instruments and accessories used to maintain the spectrum analyzer are listed in Table 1-4. If the listed instrument is not available, another instrument that meets the required minimum specifications may be substituted.

8-7. MAJOR ASSEMBLY LOCATIONS

8-8. The major assembly location illustration for the spectrum analyzer is located in the Major Assembly and Component Locations Tab.

8-9. TROUBLESHOOTING

8-10. General Information

8-11. Troubleshooting is most easily accomplished by using the block diagram at the end of this section to follow the signal path. Once the problem is isolated to a particular circuit, the circuit description and schematic diagram can be used to locate the faulty component.

NOTE

When a part is replaced, adjustment of the affected circuitry is usually required. For adjustment procedures, refer to Section V.

CAUTION

Improper cleaning of the printed circuit board edge connectors can cause damage to the contact's gold plating, resulting in corrosion and intermittent electrical contact. Use only the recommended procedure.

8-12. Printed Circuit Board Edge Connector Contact Cleaning

MATERIALS:

- Lint-free cloth or equivalent (HP Part Number 9310-0039, Check Digit 3).
- Solution of 80% electronics-grade isopropyl alcohol and 20% water.
- Static-free work station.

PROCEDURE:

1. Dampen the cloth with the alcohol and water solution and scrub the edge connector contacts vigorously, using a circular motion. Polish one side of the board at a time until the contacts shine, keeping the cloth damp to dissolve contaminants and reduce static electricity.
2. Using a clean cloth, dry the contacts by wiping from their inside to outside edge. This prevents particles from building up on the contact edges.

CAUTION

Do not use erasers to clean the edge connectors. They cause microscopic

damage to the contact surface, removing the thin gold plating and exposing the nickel under-plating, which eventually corrodes. Erasers also leave a film on the contact and generate static electricity.

Do not use paper of any kind to clean the edge connector contacts. Paper or lint particles left on the edge contact surface can cause intermittent electrical connections.

Do not touch contact or trace surfaces with bare hands. Always handle the board by its edges.

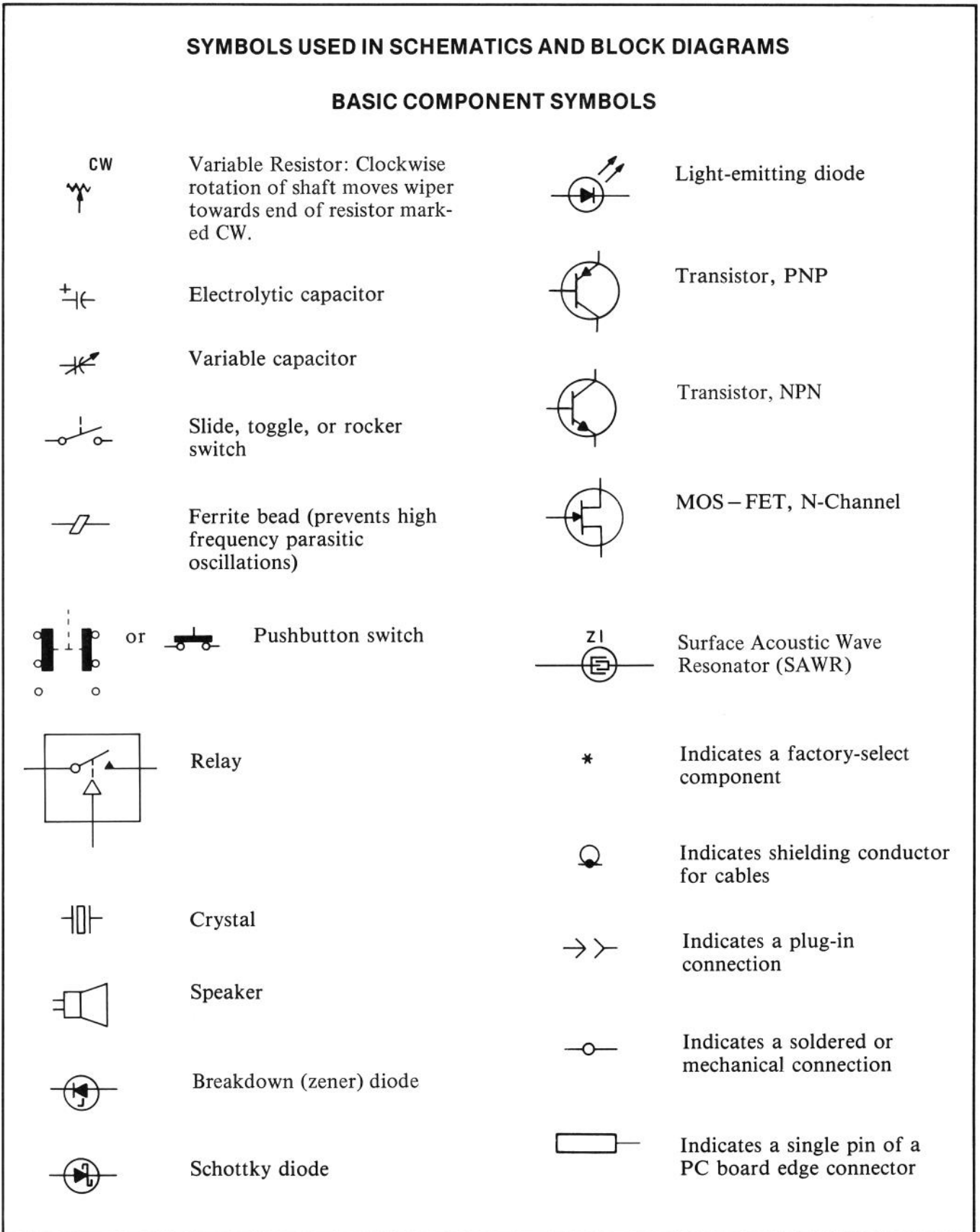











FIGURE 8-1. SYMBOLS USED IN SCHEMATICS AND BLOCK DIAGRAMS (1 OF 4)

SYMBOLS USED IN SCHEMATICS AND BLOCK DIAGRAMS

BASIC COMPONENT SYMBOLS

	Connection symbol indicating a Jack (except for PC board edge connectors)		Indicates wire or cable color code. Color code same as resistor color code. First number indicates base color, second and third numbers indicate colored stripes.
	Connection symbol indicating a Plug (except for PC board edge connectors)		Earth ground
	Test Point: Terminal provided for test probe.		Instrument chassis ground. May be accompanied by a number or letter to specify a particular ground.
	Measurement Point: Used to indicate a convenient point for measurement. No terminal provided for test probe.		Screwdriver adjustment
			Front-panel control
			Jumper wire

COMMONLY USED ASSEMBLY AND CIRCUIT SYMBOLS





	Oscillator		Mixer
	Operational amplifier		Inverter, buffer
	Tuneable cavity		Transmission Line

FIGURE 8-1. SYMBOLS USED IN SCHEMATICS AND BLOCK DIAGRAMS (2 OF 4)

SYMBOLS USED IN SCHEMATIC AND BLOCK DIAGRAMS

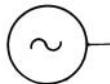
BASIC LOGIC SYMBOLS

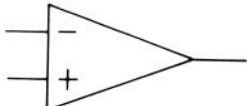
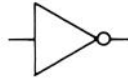
Distinctive-Shape Symbols

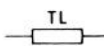
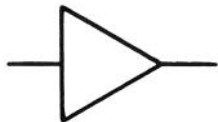

AMPLIFIER/BUFFER

Output is active when input is active.

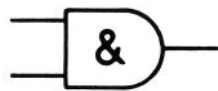

AND FUNCTION

Output is active only when all inputs are active.

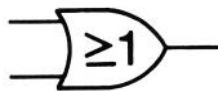

OR FUNCTION

Output is active when one or more inputs are active.

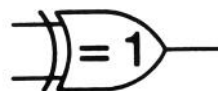

EXCLUSIVE-OR
FUNCTION

Output is active when only one input is active.

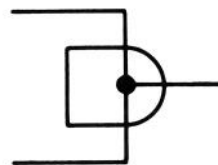

WIRED AND
FUNCTION

Two or more elements are joined together to achieve the effect of an AND function.

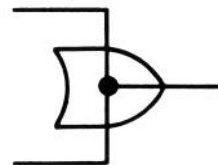

WIRED OR
FUNCTION

Two or more elements are joined together to achieve the effect of an OR function.

FIGURE 8-1. SYMBOLS USED IN SCHEMATICS AND BLOCK DIAGRAMS (3 OF 4)

SYMBOLS USED IN SCHEMATIC AND BLOCK DIAGRAMS

BASIC LOGIC SYMBOLS

Indicator Symbols (positive logic assumed)

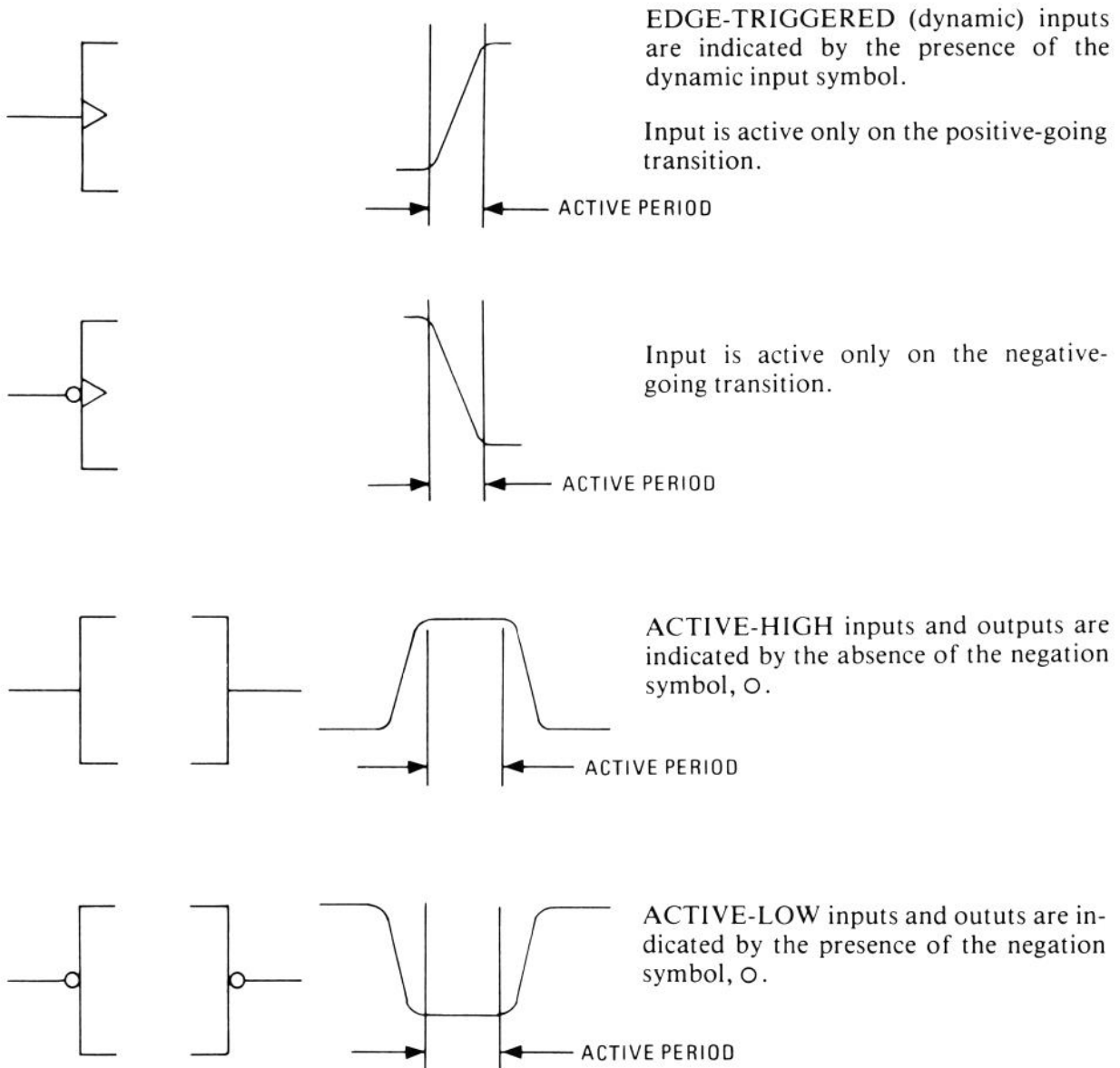
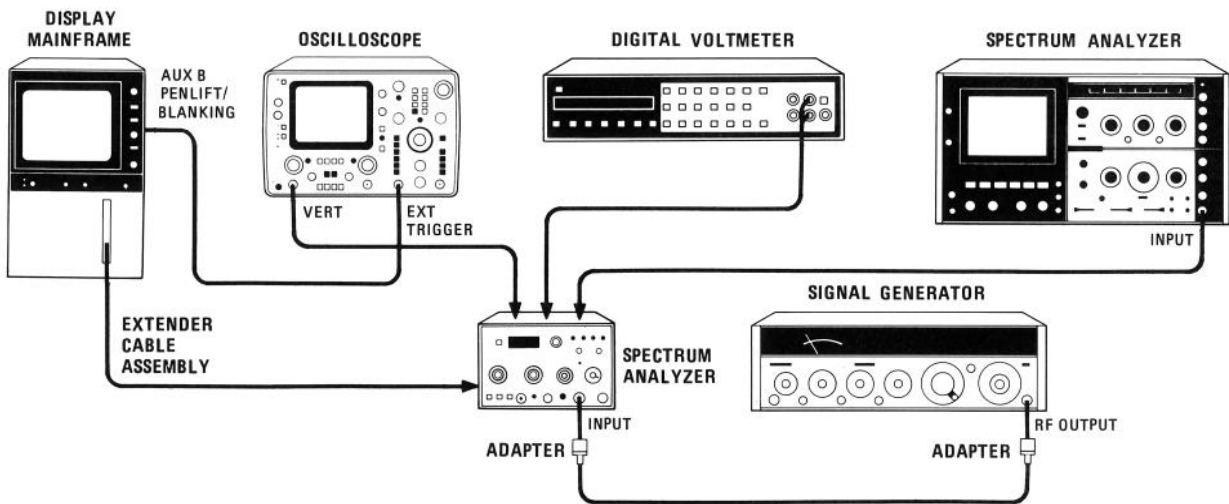

FIGURE 8-1. SYMBOLS USED IN SCHEMATICS AND BLOCK DIAGRAMS (4 OF 4)

Nominal power levels, voltages, and waveforms shown on schematic diagrams were measured using the test setup shown below. Note that signal characteristics shown on schematic diagrams are provided as a troubleshooting aid only. They should not be used for making instrument adjustments.



EQUIPMENT:

Oscilloscope (with 10:1 probe)	HP 1741A
Spectrum Analyzer	HP 141T/8552B/8555A
Digital Voltmeter	HP 3455A
Signal Generator	HP 8640B
Extender Cable Assembly	HP 5060-0303
Adapter, Type N to BNC (2 required).	HP 1250-0780

FIGURE 8-2. CONDITIONS FOR SCHEMATIC DIAGRAM MEASUREMENTS (1 OF 2)

PROCEDURE:

1. Set HP 8558B Spectrum Analyzer controls as follows:

START-CENTER	CENTER
TUNING	280 MHz
FREQ SPAN/DIV	1 MHz
RESOLUTION BW	300 kHz
INPUT ATTEN	0 dB
REFERENCE LEVEL	-10 dBm
<i>Option 002: +40 dBmV</i>	
REFERENCE LEVEL FINE	0
Amplitude Scale	10 dB/DIV
SWEEP TIME/DIV	AUTO
SWEEP TRIGGER	FREE RUN
VIDEO FILTER	OFF
BASELINE CLIPPER	OFF
BL CLIP	OFF

2. Connect equipment as shown. Set signal generator for a 280 MHz, -10 dBm output signal. Center the signal on the display.
3. Using board extenders when necessary, check voltages and waveforms indicated on schematic diagrams. Trigger oscilloscope on negative transition of AUX B PENLIFT/BLANKING signal from rear of display mainframe.
4. To measure RF power levels, set RESOLUTION BW control to 3 MHz and FREQ SPAN/DIV to 0 (zero span). The first LO is not swept in zero span, allowing signal levels to be checked with a second spectrum analyzer (use adapter cables as necessary). DO NOT use a power meter (harmonics and LO signals will contribute to give erroneous levels).

FIGURE 8-2. CONDITIONS FOR SCHEMATIC DIAGRAM MEASUREMENTS (2 OF 2)

THE HP 8558B SPECTRUM ANALYZER THEORY OF OPERATION

General Information

The HP 8558B is a spectrum analyzer plug-in module for use with either the HP 180 series or HP 853A display mainframes. It tunes from 0.1 MHz to 1500 MHz and displays frequency spans as wide as 1 GHz and as narrow as 50 kHz. A zero span feature enables the analyzer to operate as a tunable, fixed-frequency receiver. Resolution bandwidths of 3 MHz to 1 kHz are selectable in a 1-3-10 sequence. CRT display calibration can be maintained by coupling the frequency span, resolution bandwidth, and video filter to an automatic sweep time control. The resolution bandwidth and frequency span controls can be locked together to function as a "zoom" control. A four-LED numerical display allows direct readout of the display center frequency or the tunable marker frequency.

The adjustable reference-level control is calibrated to allow direct readout of amplitudes ranging from -111 to $+30$ dBm. Continuous wave (CW) signals at or below the Reference Level, the top display graticule, are automatically below the analyzer's gain compression specification. Dynamic range is greater than 70 dB.

The typical spectrum analyzer comprises three main sections: the RF section, the IF section, and the display section. Since it is a plug-in designed to work with a display mainframe, the HP 8558B houses only the RF and IF sections. The display and power supply are contained in the mainframe.

RF Section

The HP 8558B RF section resembles a triple-conversion superheterodyne receiver; input signal frequencies are converted three times before processing for display. Triple conversion makes possible wide frequency coverage and permits filtering and amplification at more easily controlled frequencies.

RF Attenuator. The stepped RF Input Attenuator Assembly A3, at the input to the RF section, attenuates the input in precise 10 dB steps from 0 to 70 dB. Precise and repeatable attenuation and gain in the signal path are necessary to preserve amplitude calibration and direct reading of signal amplitudes on the CRT. RF attenuator adjustment establishes the optimum signal level applied to the First Converter Assembly A4.

First Converter. Within the First Converter Assembly A4, the incoming signal mixes with the first local oscillator, generating the first IF (2.05 GHz).

First LO. A YIG-Tuned Oscillator Assembly A6, or YTO, is used as the first LO. YIG, yttrium-iron-garnet, is a ferro-magnetic material which is polished into a small sphere and precisely oriented in a magnetic field. Changes in this magnetic field alter the frequency generated by the YTO. For the YTO in the HP 8558B, a frequency range of 2.05 GHz to 3.55 GHz is used. Voltage control of the magnetic field surrounding the YIG sphere allows the analyzer to be swept or tuned within these frequency limits. A control voltage, derived from the sweep generator, tunes the YTO in sync with the horizontal deflection of the CRT beam. A tuning voltage offsets the sweep to establish the center frequency. Voltage control of the analyzer's frequency is convenient, since low frequency circuits, like operational amplifiers and transistors, can generate and modify the control voltage.

Second Converter. The Second Converter Assembly A5 houses the 2.05 GHz bandpass filter, the second mixer, and the second LO. The 2.05 GHz filter uses the resonant characteristics of three precisely machined cavities, or holes, in the aluminum block housing to filter the first IF. A fourth cavity is used as the resonant circuit for the second LO, which operates at a fixed frequency of 1748.6 MHz. After mixing with the first IF, the second LO produces the second IF at 301.4 MHz.

Third Converter. The Third Converter Assembly A9 contains the third mixer, the third LO, and IF filter and compensation amplifiers. The double-balanced third mixer produces sum and difference frequencies, as do other mixers, but rejects input and LO frequencies, simplifying subsequent filtering. The third LO, fixed at 280 MHz, when mixed with the 301.4 MHz second IF, produces a difference frequency at the final IF, 21.4 MHz.

Three conversions or frequency translations are necessary before the input signal reaches the final IF, where the analyzer's major bandpass filtering and calibrated gains occur. The circuits used in the final IF are more easily controlled at 21.4 MHz than they would be at the higher input frequencies. The RF section's function is to down-convert the input signal accurately so the analyzer can control and display it. Circuitry providing flatness compensation to the third converter is also included on the A9 assembly.

IF Section

The IF section comprises the third IF filters and amplifiers, and the step gain and logarithmic amplifiers. It also includes the video detector, video filters, and video amplifiers. The IF section processes the 21.4 MHz output of the Third Converter Assembly A9 and applies it to the vertical deflection circuitry in the display mainframe.

The 21.4 MHz third converter output is processed by the Bandwidth Filter No. 1 Assembly A11, the Step Gain Assembly A12, the Bandwidth Filter No. 2 Assembly A13, the Log Amplifier Assembly A14, and, finally, the Vertical Driver Assembly A15. Each assembly occupies a separate printed circuit board, which is shielded by extrusions mounted on the Motherboard Assembly A16.

Bandwidth Filters. Bandwidth Filter No. 1 Assembly A11 and Bandwidth Filter No. 2 Assembly A13 are identical; each contains two synchronously-tuned filter poles isolated by buffer amplifiers. Synchronously-tuned filter poles have identical center frequencies, unlike stagger-tuned poles. The bandwidth of these poles, varying from 3 MHz to 1 kHz, is changed simultaneously by the front panel RESOLUTION BW control. Because the variable bandwidths are so much narrower than any of the RF section bandpass filters, the RESOLUTION BW control setting determines the analyzer's overall bandwidth. Parallel LC filters provide bandwidths from 3 MHz to 100 kHz. Crystal filters provide the narrow, 30 kHz to 1 kHz, bandwidths.

Step Gain Amplifier. Located between the bandwidth filter assemblies, the Step Gain Assembly A12 provides precise and selectable gain in three stages, a 10 dB stage followed by two 20 dB stages. Each stage can be turned "on" for full gain or "off" for unity gain. By turning on the amplifiers in combination, gains of 0 to 50 dB may be selected. This action is performed by the REFERENCE LEVEL control. Concentric with the REFERENCE LEVEL knob is the REF LEVEL FINE potentiometer, which controls the 0 to 12 dB PIN diode attenuator.

Logarithmic Amplifier. The second bandwidth filter is followed by the Log Amplifier Assembly A14. The gain of this amplifier is a logarithmic function of the input signal, which allows a greater range of signal amplitudes to be simultaneously displayed on the CRT. This logarithmic amplification of the signal before detection results in the vertical display axis being calibrated in decibels (relative to a milliwatt), rather than volts. Linear amplification from 0 dB to 40 dB may also be selected from the front panel.

The video detector, located on the Log Amplifier Assembly A14, is basically a half-wave rectifier and a filter. This circuit produces a voltage proportional to the signal level, called the video signal. This signal passes through a video filter and a vertical deflection driver and blanking amplifier A15 before leaving the HP 8558B.

TROUBLESHOOTING HINTS

Begin troubleshooting by measuring the mainframe-supplied voltages. The Vertical Driver/Blanking Assembly A15 offers three test points to make the measurements. If any of these voltages are low, refer to the mainframe Operation and Service manual and make the necessary adjustments before continuing. Common symptoms caused by low mainframe-supplied voltages include: increased residual FM (caused by a low +15V supply) and poor frequency accuracy or intermittent lockup of the frequency display LED's (also caused by a low power supply).

If the supply voltages are correct, use the block diagram at the end of this section to follow the signal path. Isolate the failure to a particular circuit and use the circuit descriptions and schematic diagrams to locate the faulty component.

Residual FM

Residual FM is an undesired frequency modulation of a local oscillator (LO). It appears as noise riding on the displayed trace and may be random or cyclical (usually as a function of the line frequency). The following procedure is a guide for isolating a source of residual FM. Further troubleshooting hints concerning residual FM are included following the circuit descriptions of the indicated assemblies. Table 8-1 shows how certain components affect FM in these procedures. Note that the zener diode causes peaks which are sharp and extreme compared to the IC peaks. A leaky electrolytic capacitor (not shown) usually causes the displayed signal to step down and remain at the same level for several divisions before stepping up to a new level.

Set HP 8558B controls as follows:

TUNING	280 MHz
FREQ SPAN/DIV	0
RESOLUTION BW	300 kHz
INPUT ATTEN	0 dB
REFERENCE LEVEL	-10 dB
REF LEVEL FINE	0
Amplitude Scale	10 dB/DIV
SWEEP TIME/DIV	AUTO
SWEEP TRIGGER	OFF
VIDEO FILTER	OFF
BL CLIP	OFF

- Verify that the mainframe supply voltages are correct at the Vertical Driver/Blanking Assembly A15 of the HP 8558B.
- Use a second spectrum analyzer to check each LO of the HP 8558B for FM.
First LO: check at the HP 8558B first LO Output jack.
Second LO: check at A5J3 on Second Converter Assembly A5.
Third LO: check at the HP 8558B front-panel CAL OUTPUT jack (from A9J2).
- If the source of FM is the first LO, check the Frequency Control Assembly A7 and the YIG-Tuned Oscillator Assembly A6 by following the steps in Table 8-1.
- If the source of FM is the second LO, a possible FM source is A5CR1 or A5Q1. The LO should not vary more than 200 kHz.
- If the source of the FM is the third LO, check the Third Converter Assembly A10.

Sideband Noise

Sideband noise is usually caused by YIG Oscillator Assembly A6.

Spurious Responses

Spurious responses are usually caused by loose RF connections. Check all the RF connections.

Baseline Step

If the left side of the baseline lifts to the signal peak level, the trouble is A7Q17; a lift of the right side of the baseline is caused by A7Q18 (see Figure 8-4).

TABLE 8-1. RESIDUAL FM TROUBLESHOOTING PROCEDURE (1 OF 2)

Troubleshooting Step	Probable FM Source
1. Set HP 8558B controls as follows: INPUT ATTEN 0 dB REF LEVEL -20 <i>(Option 002: +30 dBmV)</i> FREQ SPAN/DIV 2 MHz RESOLUTION BW 1 MHz SWEEP TIME/DIV AUTO SWEEP TRIGGER FREE RUN AMPLITUDE SCALE LIN VIDEO FILTER OFF	
2. Tune LO feedthrough to the left edge of CRT display and make sure a double lobe (Figure 8-3d) does not occur.	Main Coil Filter A7Q4 and associated circuitry.
3. Connect CAL OUTPUT to spectrum analyzer input. Center 280 MHz signal on CRT and adjust REF LEVEL FINE for a top-of-screen signal.	
4. Step FREQ SPAN/DIV from 2 MHz to 1 MHz. Frequency shift should be less than one major division.	Main Coil Filter A7Q4 and associated circuitry.
5. Use FREQUENCY CAL pushbutton to remove YIG hysteresis, then center 280 MHz signal on CRT. Repeated operations should shift signal less than one major division.	Calibrate single shot A7Q21 – 23. Proceed to step 11.
6. Check the voltages at A7TP6 and A7TP7 for correct level and stability. A7TP6 ≈ +6V A7TP7 ≈ +14.5V	A7VR2 A7VR1
7. Select a 10 kHz RESOLUTION BW and tune the spectrum analyzer so the 280 MHz signal skirt crosses the center frequency graticule line between the fourth and seventh horizontal graticule lines. Switch to zero (0) span and select a .1 SEC/DIV sweep time. Peak-to-peak variations of the trace should not exceed one major vertical division for each major horizontal division.	
8. Try FM check (step 7) with TUNING potentiometer in several different positions. (Tune slightly off frequency with COARSE TUNING control and adjust FINE TUNING control for proper display.)	TUNING potentiometer
9. Disconnect one end of A7C13 and repeat step 7. Reconnect A7C13, disconnect one end of A7C4, and again repeat step 7.	A7C13 or A7C14

TABLE 8-1. RESIDUAL FM TROUBLESHOOTING PROCEDURE (2 OF 2)

Troubleshooting Step	Probable FM Source
10. Remove A7CR2 and A7Q22. If FM is still present, remove A7Q21 and A7Q23.	Calibrate single shot circuit on Frequency Control Assembly A7.
11. Remove A7R55 and repeat step 7.	YIG FM coil driver circuit on Frequency Control Assembly A7. Probably A7U1.
12. Disconnect one end of A7VR3 or A7CR9 and repeat step 7.	A7VR3 or A7CR9
13. Ground A7TP1 and repeat step 7.	YIG main coil gate on Frequency Control Assembly A7.
14. If residual FM is still present, the problem is in the YIG main coil drivers on Frequency Control Assembly A7. Refer to the Frequency Control Assembly schematic diagram for further troubleshooting.	

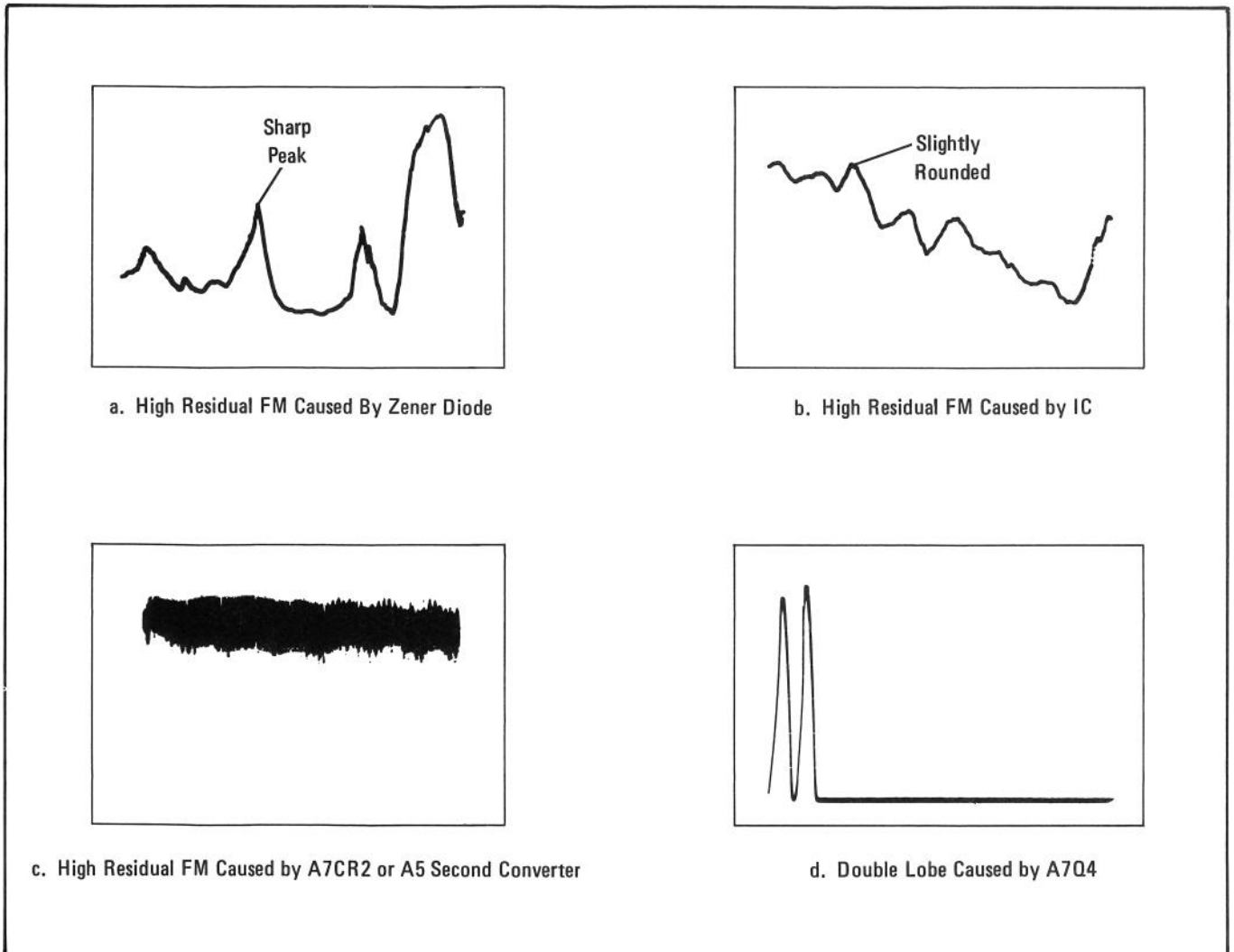

FIGURE 8-3. CRT DISPLAYS FOR RESIDUAL FM TROUBLESHOOTING

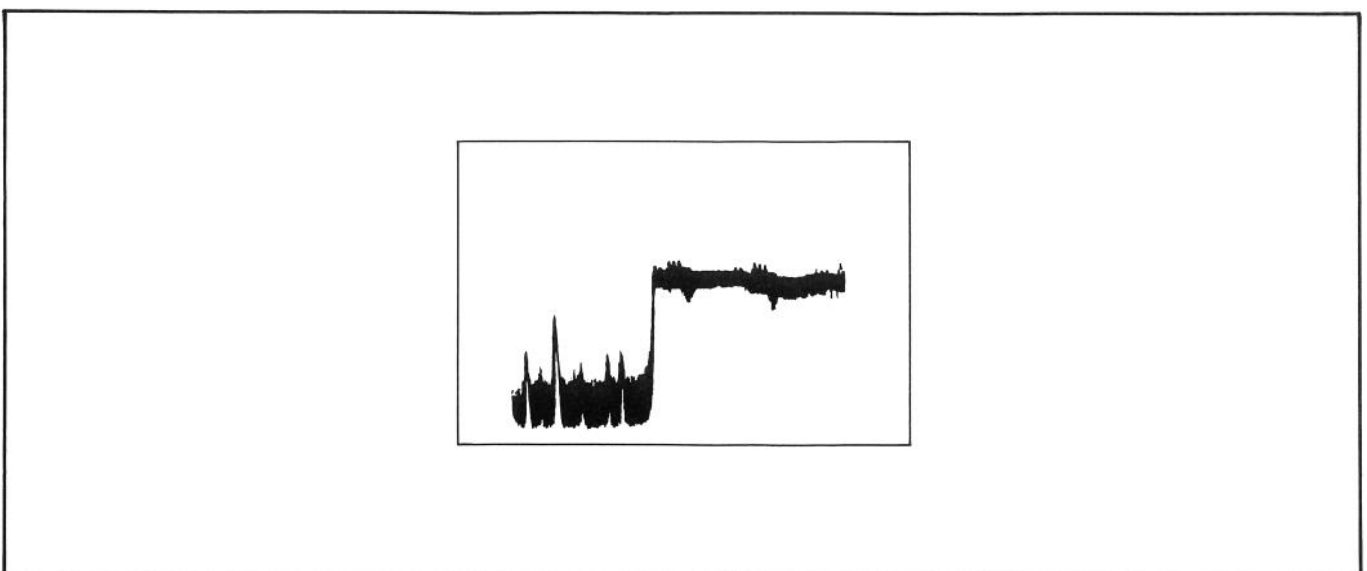

FIGURE 8-4. BASELINE STEP CAUSED BY FAILURE OF A7Q18

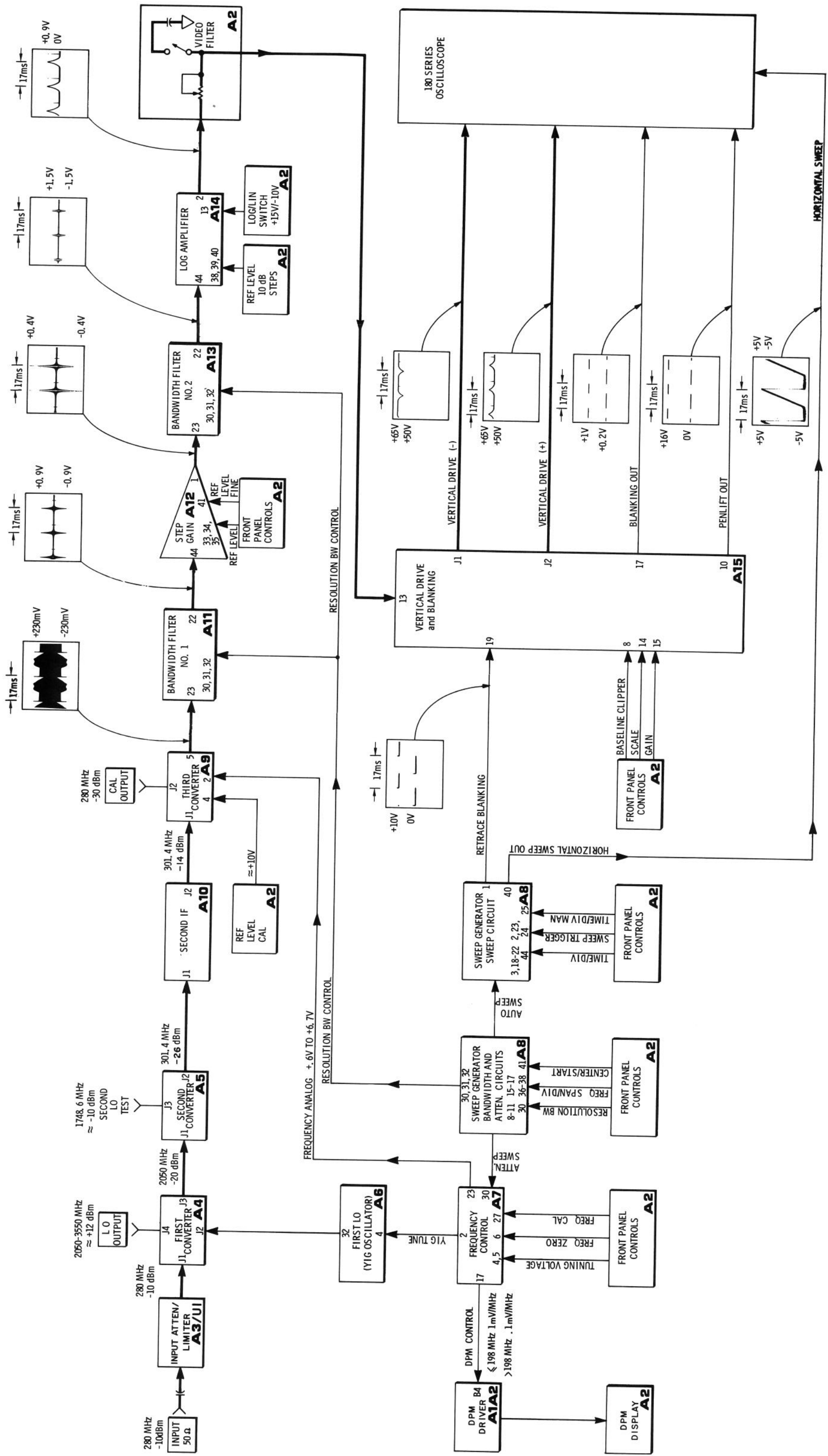
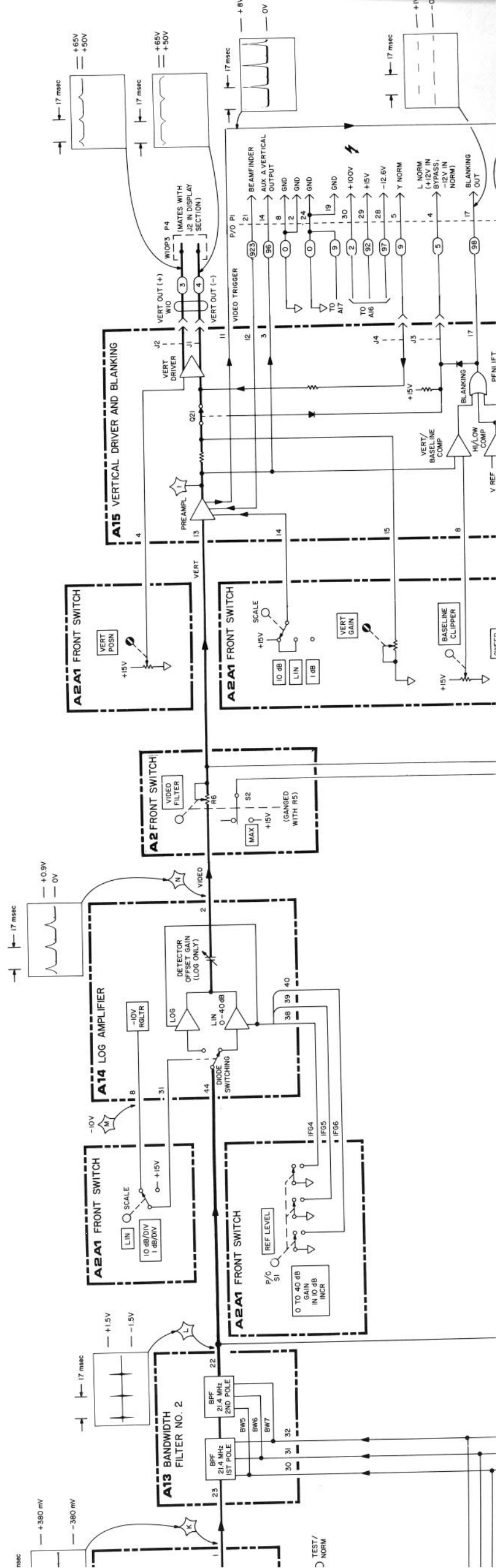
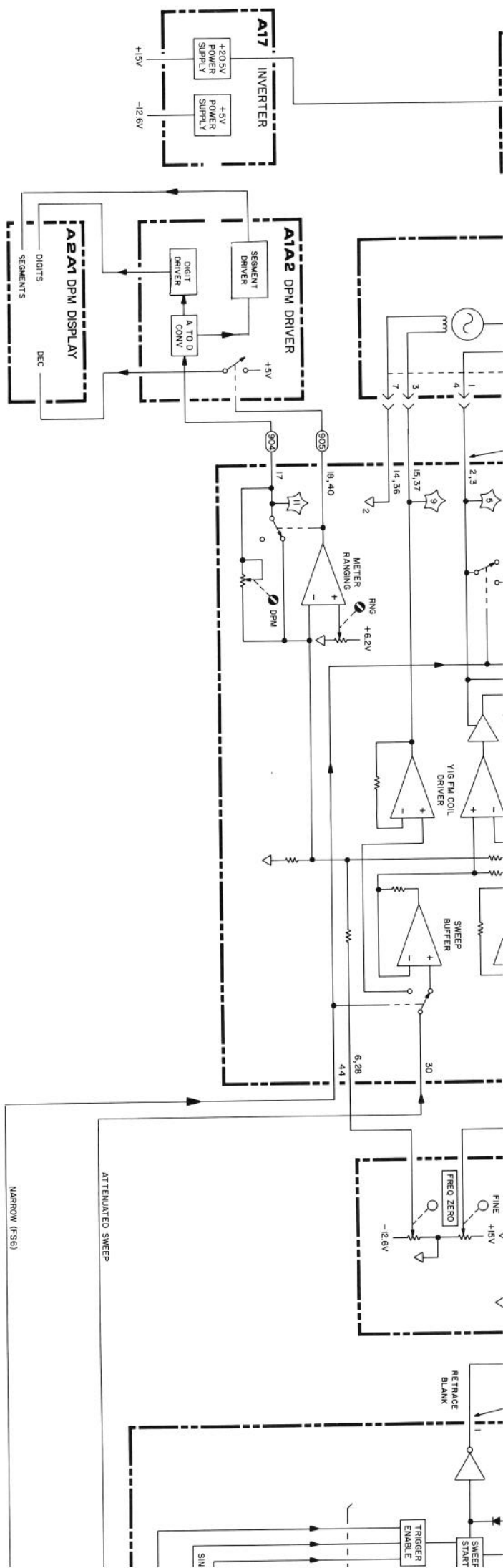

FIGURE 8-5. SIMPLIFIED BLOCK DIAGRAM
8-17/8-18

NOMINAL POWER LEVELS - OPTIONS	
OPTION CODE:	OPTION CODE:
INPUT LEVEL	INPUT LEVEL
A	P
B	Q
C	R
D	S
E	T
F	U
G	V
H	W
I	X
J	Y
K	Z
L	AA
M	AB
N	AC
O	AD
P	AE
Q	AF
R	AG
S	AH
T	AI
U	AJ
V	AK
W	AL
X	AM
Y	AN
Z	AO
AA	AP
AB	AQ
AC	AR
AD	AS
AE	AT
AF	AU
AG	AV
AH	AW
AI	AX
AJ	AY
AK	AZ
AL	BA
AM	BB
AN	BC
AO	BD
AP	BE
AQ	BF
AR	BG
AS	BH
AT	BI
AU	BJ
AV	BK
AW	BL
AX	BM
AY	BN
AZ	BO
BA	BP
BB	BQ
BC	BR
BD	BS
BE	BT
BF	BU
BG	BV
BH	BW
BI	BX
BJ	BY
BK	BZ
BL	CA
BM	CB
BN	CC
BO	CD
BP	CE
BQ	CF
BR	CG
BS	CH
BT	CI
BU	CJ
BV	CK
BW	CL
BX	CM
BY	CN
BZ	CO
CA	CP
CB	CQ
CC	CR
CD	CS
CE	CT
CF	CU
CG	CV
CH	CW
CI	CX
CJ	CY
CK	CZ
CL	DA
CM	DB
CN	DC
CO	DD
CP	DE
CQ	DF
CR	DG
CS	DH
CT	DI
CU	DJ
CV	DK
CW	DL
CX	DM
CY	DN
CZ	DO
DA	DP
DB	DQ
DC	DR
DD	DS
DE	DT
DF	DU
DG	DV
DH	DW
DI	DX
DJ	DY
DK	DZ
DL	EA
DM	EB
DN	EC
DO	ED
DP	EE
DQ	EF
DR	EG
DS	EH
DT	EI
DU	EJ
DV	EK
DW	EL
DX	EM
DY	EN
DZ	EO
EA	EP
EB	EQ
EC	ER
ED	ES
EE	ET
EF	EU
EG	EV
EH	EW
EI	EX
EJ	EY
EK	EZ
EL	FA
EM	FB
EN	FC
EO	FD
EP	FE
EQ	FF
ER	FG
ES	FH
ET	FI
EU	FJ
EV	FK
EW	FL
EX	FM
EY	FN
EZ	FO
FA	FP
FB	FQ
FC	FR
FD	FS
FE	FT
FF	FU
FG	FV
FH	FW
FI	FX
FJ	FY
FK	FZ
FL	GA
FM	GB
FN	GC
FO	GD
FP	GE
FQ	GF
FR	GG
FS	GH
FT	GI
FU	GJ
FV	GK
FW	GL
FX	GM
FY	GN
FZ	GO
GA	GP
GB	GQ
GC	GR
GD	GS
GE	GT
GF	GU
GG	GV
GH	GW
GI	GX
GJ	GY
GK	GZ
GL	HA
GM	HB
GN	HC
GO	HD
GP	HE
GQ	HF
GR	HG
GS	HH
GT	HI
GU	HJ
GV	HK
GW	HL
GX	HM
GY	HN
GZ	HO
HA	HP
HB	HQ
HC	HR
HD	HS
HE	HT
HF	HU
HG	HV
HH	HW
HI	HX
HJ	HY
HK	HZ
HL	IA
HM	IB
HN	IC
HO	ID
HP	IE
HQ	IF
HR	IG
HS	IH
HT	II
HU	IJ
HV	IK
HW	IL
HX	IM
HY	IN
HZ	IO
IA	IP
IB	IQ
IC	IR
ID	IS
IE	IT
IF	IU
IG	IV
IH	IW
II	IX
IJ	IY
IK	IZ
IL	JA
IM	JB
IN	JC
IO	JD
IP	JE
IQ	JF
IR	JG
IS	JH
IT	JI
IU	JK
IV	JL
IW	JM
IX	JN
IY	JO
IZ	JP
JA	jq
JB	Jr
JC	Js
JD	Jt
JE	Ju
JF	Jv
JG	Jw
JH	Jx
JI	Jy
JK	Jz
JL	KA
JM	KB
JN	KC
JO	KD
JP	KE
jq	KF
Jr	KG
Js	KH
Jt	KI
Ju	KJ
Jv	KK
Jw	KL
Jx	KM
Jy	KN
Jz	KO
KA	KP
KB	KQ
KC	KR
KD	KS
KE	KT
KF	KU
KG	KV
KH	KW
KI	KX
KJ	KY
KK	KZ
KL	LA
KM	LB
KN	LC
KO	LD
KP	LE
KQ	LF
KR	LG
KS	LH
KT	LI
KU	LJ
KV	LK
KW	LL
KX	LM
KY	LN
KZ	LO
LA	LP
LB	LQ
LC	LR
LD	LS
LE	LT
LF	LU
LG	LV
LH	LW
LI	LX
LJ	LY
LK	LZ
LL	MA
LM	MB
LN	MC
LO	MD
LP	ME
LQ	MF
LR	MG
LS	MH
LT	MI
LU	MJ
LV	MK
LW	ML
LX	MM
LY	MN
LZ	MO
MA	MP
MB	MQ
MC	MR
MD	MS
ME	MT
MF	MU
MG	MV
MH	MW
MI	MX
MJ	MY
MK	MZ
ML	NA
MM	NB
MN	NC
MO	ND
MP	NE
MQ	NF
MR	NG
MS	NH
MT	NI
MU	NJ
MV	NK
MW	NL
MX	NM
MY	NN
MZ	NO
NA	NP
NB	NQ
NC	NR
ND	NS
NE	NT
NF	NU
NG	NV
NH	NW
NI	NX
NJ	NY
NK	NZ
NL	OA
NM	OB
NN	OC
NO	OD
NP	OE
NQ	OF
NR	OG
NS	OH
NT	OI
NU	OJ
NV	OK
NW	OL
NX	OM
NY	ON
NZ	OO
OA	OP
OB	OQ
OC	OR
OD	OS
OE	OT
OF	OU
OG	OV
OH	OW
OI	OX
OJ	OY
OK	OZ
OL	PA
OM	PB
ON	PC
OO	PD
OP	PE
OQ	PF
OR	PG
OS	PH
OT	PI
OU	PJ
OV	PK
OW	PL
OX	PM
OY	PN
OZ	PO
PA	PP
PB	PQ
PC	PR
PD	PS
PE	PT
PF	PU
PG	PV
PH	PW
PI	PX
PJ	PY
PK	PZ
PL	QA
PM	QB
PN	QC
PO	QD
PP	QE
PQ	QF
PR	QG
PS	QH
PT	QI
PU	QJ
PV	QK
PW	QL
PX	QM
PY	QN
PZ	QO
QA	QP
QB	QR
QC	QS
QD	QT
QE	QU
QF	QV
QG	QW
QH	QX
QI	QY
QJ	QZ
QK	RA
QL	RB
QM	RC
QN	RD
QO	RE
QP	RF
QR	RG
QS	RH
QT	RI
QU	RJ
QV	RK
QW	RL
QX	RM
QY	RN
QZ	RO
RA	RP
RB	RQ
RC	RR
RD	RS
RE	RT
RF	RU
RG	RV
RH	RW
RI	RX
RJ	RY
RK	RZ
RL	SA
RM	SB
RN	SC
RO	SD
RP	SE
RQ	SF
RR	SG
RS	SH
RT	SI
RU	SJ
RV	SK
RW	SL
RX	SM
RY	SN
RZ	SO
SA	SP
SB	SQ
SC	SR
SD	SS
SE	ST
SF	SU
SG	SV
SH	SW
SI	SX
SJ	SY
SK	SZ
SL	TA
SM	TB
SN	TC
SO	TD
SP	TE
SQ	TF
SR	TG
SS	TH
ST	TI
SU	TJ
SV	TK
SW	TL
SX	TM
SY	TN
SZ	TO
TA	TP
TB	TQ
TC	TR
TD	TS
TE	TT
TF	TU
TG	
TH	TW
TI	TX
TJ	TY
TK	TZ
TL	UA
TM	UB
TN	UC
TO	UD
TP	UE
TQ	UF
TR	UG
TS	UH
TT	UI
TU	UJ
TV	UK
TW	UL
TX	UM
TY	UN
TZ	UO
UA	UP
UB	UQ
UC	UR
UD	US
UE	UT
UF	UU
UG	UV
UH	UW
UI	UX
UJ	UY
UK	UZ
UL	VA
UM	VB
UN	VC
UO	VD
UP	VE
UQ	VF
UR	VG
US	VH
UT	VI
UU	VJ
UV	VK
UW	VL
UX	VM
UY	VN
UZ	VO
VA	VP
VB	VQ
VC	VR
VD	VS
VE	VT
VF	VU
VG	VV
VH	VW
VI	VX
VJ	VY
VK	VZ
VL	WA





SERIAL PREFIX: 2147A

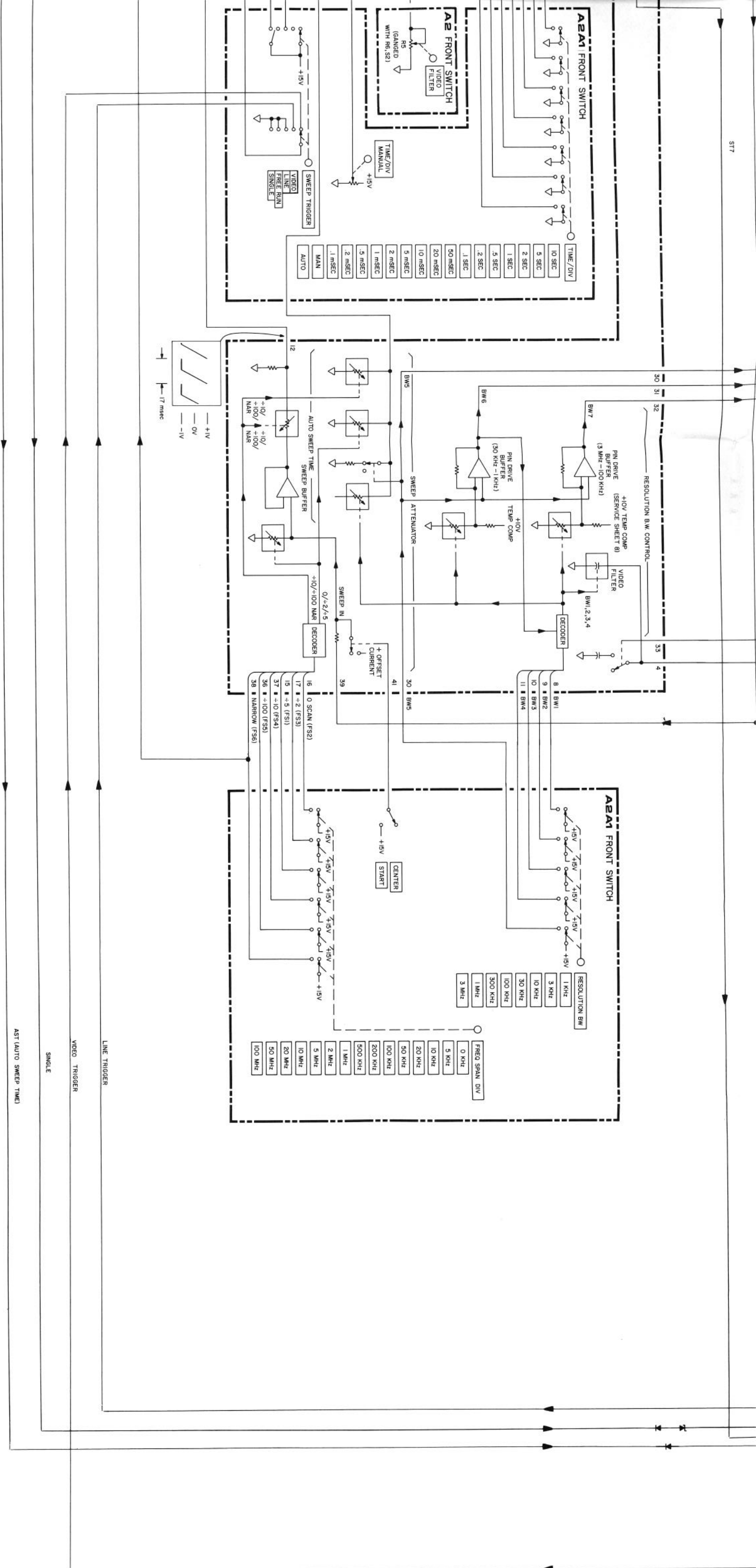

FIGURE 8-6. TROUBLESHOOTING BLOCK DIAGRAM

A1A2 DPM DRIVER ASSEMBLY, CIRCUIT DESCRIPTION

The DPM circuit is a dc voltmeter that measures a tuning voltage from Frequency Control Assembly A7 and converts it to a front-panel frequency readout.

The DPM Driver is divided into three parts:

1. The Analog-to-Digital Converter
2. The Segment Driver
3. The Digit Driver

Analog-to-Digital Converter (A)

The Analog-to-Digital Converter comprises an MOS LSI device, A1A2U1, and associated circuitry. A1A2U1 compares the input voltage (MTR V) on pin 3 with a reference voltage (V REF) on pin 2 and outputs the measured voltage in a binary-coded decimal (BCD) format. The BCD data is multiplexed out of A1A2U1, one decimal digit (four bits) at a time on pins 20 through 23. DS1 through DS4 (pins 16 through 19) are enable lines for A2DS1 (MSD) through A2DS4 (LSD). A1A2R2, A1A2R3, and A1A2R4 form an adjustable voltage divider which divides the 6.2V from A16VR1 down to approximately 2.0V for the reference voltage (V REF) at pin 2 of A1A2U1.

Segment Driver (B)

A1A2U3 converts the BCD data to seven-segment data for the displays and provides a test function which lights all the segments of all the displays when pin 3 (TP2) is jumpered to ground. A1A2Q3 switches the decimal point LED on for frequencies below 198.6 MHz. (The voltage, MTR V, is multiplied by 10 on the Frequency Control Assembly.) A1A2Q4 allows the 'g' segment line of A2DS1 to go high when the input voltage (MTR V) is less than zero. This causes a minus sign (–) to be displayed.

Digit Driver (C)

The digits are enabled one at a time, sequentially, through Digit Driver A1A2U2. Each digit display is in turn enabled for 300 μ s until a 250 ms period has passed. This is the length of time A1A2U1 requires to make a new voltage measurement. After 250 ms, the new data is put out on pins 20 through 23 of A1A2U1 and the cycle repeats. (See Figures 8-8 and 8-9.)

Display (E)

The digit displays, A2DS1 through A2DS4, are of the common-cathode type. When the digit enable line (cathode) is low and a segment line is high, that segment is turned on. Although only one digit display is enabled at a time, the enable rate is fast enough to prevent visible display flicker.

Troubleshooting

To check the digit displays, jumper A1A2TP2 (LT) to ground. All segments of all four numeric displays (A2DS1 through A2DS4) should light. To troubleshoot DPM Driver A1A2, check for proper clock and outputs at A1A2U1 (see Figures 8-7, 8-8, and 8-9, and Table 8-2).

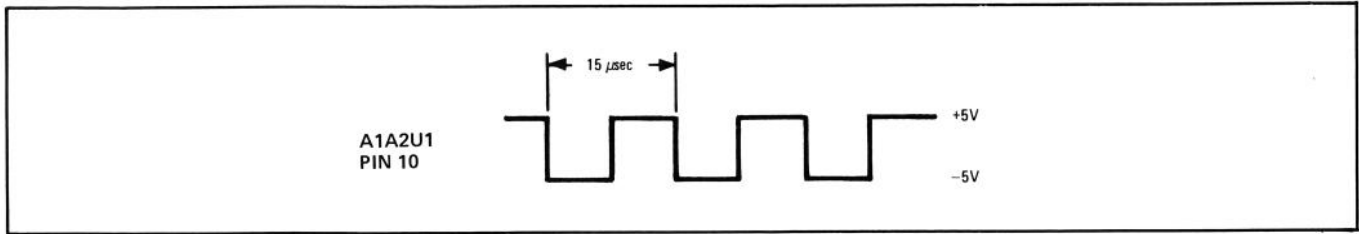

FIGURE 8-7. A1A2U1 CLOCK

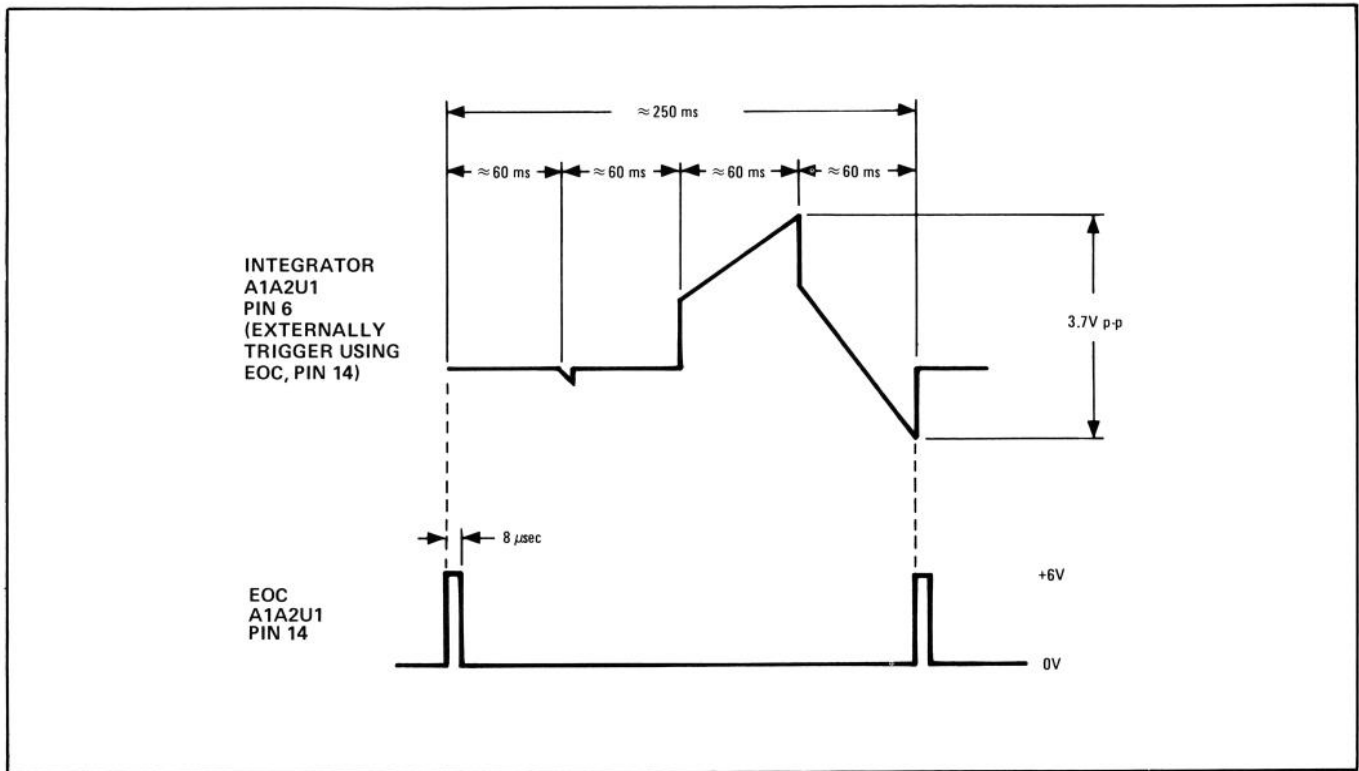
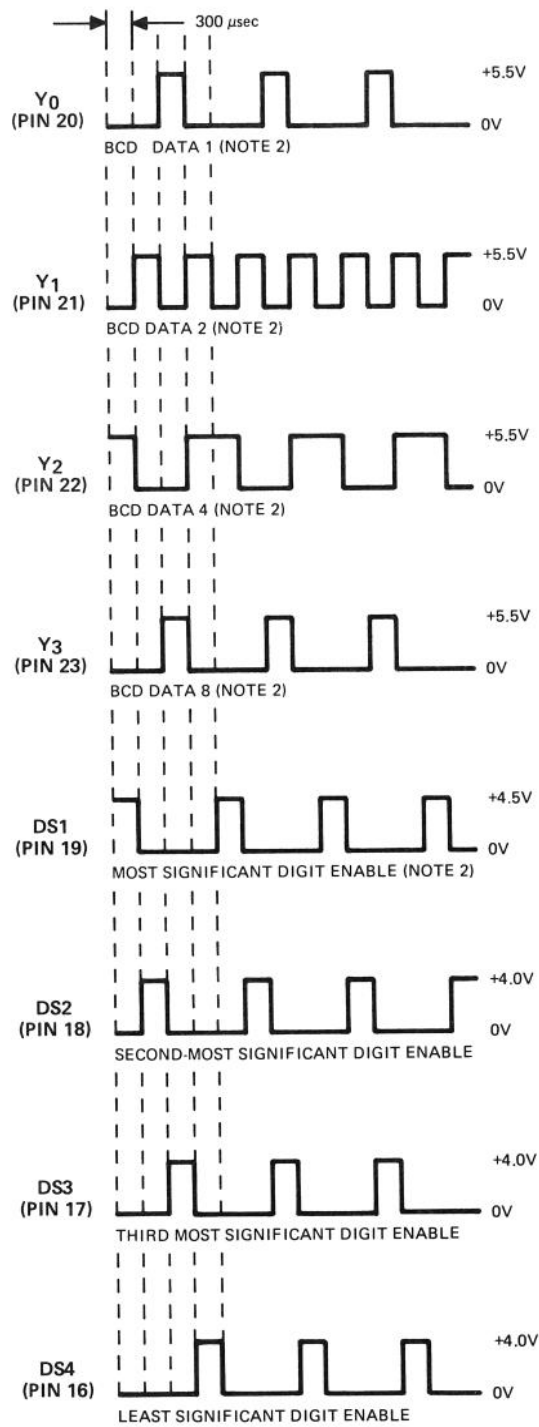

FIGURE 8-8. INTEGRATOR AND EOC WAVEFORMS FOR FREQUENCY MHz DISPLAY OF 1296 MHz

TABLE 8-2. TRUTH TABLE FOR A2DS1 DISPLAY

A1A2U1 Data Output				Decimal Equivalent	A1A1DS1 Display
Y ₃	Y ₂	Y ₁	Y ₀		
0	0	0	0	0	-1
0	0	1	1	3	-1
0	1	0	0	4	1
0	1	1	1	7	1
1	0	1	0	10	-
1	0	1	1	11	-
1	1	1	0	14	Blank
1	1	1	1	15	Blank



NOTES

1. TRIGGER OSCILLOSCOPE EXTERNALLY USING EOC (END OF CONVERSION), A1A2U1 PIN 14.
2. DURING THE TIME INTERVAL THAT DS1 LINE IS HIGH, THE DATA ON PINS 23 THROUGH 20 IS NOT STANDARD BCD CODE. SEE TABLE 8-2.

FIGURE 8-9. A1A2U1 OUTPUTS FOR FREQUENCY MHz DISPLAY OF 1296 MHz

TABLE 8-3. A1A2 DPM DRIVER ASSEMBLY, REPLACEABLE PARTS

Reference Designation	HP Part Number	C D	Qty	Description	Mfr Code	Mfr Part Number
A1A2	08558-60125	1	1	DPM DRIVER ASSEMBLY	28480	08558-60125
A1A2C1- A1A2C3 A1A2C4 A1A2C5- A1A2C9	0180-0197	8	2	NOT ASSIGNED CAPACITOR-FXD 2.2UF+-10% 20VDC TA	56289	150D225X9020A2
A1A2C10 A1A2C11 A1A2C12 A1A2C13 A1A2C14	0160-4084 0160-4084 0180-0197	8 8 8	3	NOT ASSIGNED CAPACITOR-FXD .1UF +-20% 50VDC CER CAPACITOR-FXD .1UF +-20% 50VDC CER CAPACITOR-FXD 2.2UF+-10% 20VDC TA	28480 28480 56289	0160-4084 0160-4084 150D225X9020A2
A1A2C15 A1A2C16	0160-0160 0180-2207 0160-4084	1 5 8	1	NOT ASSIGNED CAPACITOR-FXD .1UF +-10% 200VDC POLYE CAPACITOR-FXD 100UF+-10% 10VDC TA CAPACITOR-FXD .1UF +-20% 50VDC CER	28480 56289 28480	0160-0160 150D107X9010R2 0160-4084
A1A2CR1 A1A2CR2 A1A2CR3	1901-0040 1901-0050	1 3	1	NOT ASSIGNED DIODE-SWITCHING 30V 50MA 2NS DO-35 DIODE-SWITCHING 80V 200MA 2NS DO-35	28480 28480	1901-0040 1901-0050
A1A2J1	1200-0508	0	1	SOCKET-IC 14-CONT DIP-SLDR	28480	1200-0508
A1A2L1	9100-1644	3	1	INDUCTOR RF-CH-HLD 330UH 5% .2DX.45LG.	28480	9100-1644
A1A2Q1 A1A2Q2 A1A2Q3 A1A2Q4	1854-0404 1854-0404	0 0	2	NOT ASSIGNED NOT ASSIGNED TRANSISTOR NPN SI TO-18 PD=360MW TRANSISTOR NPN SI TO-18 PD=360MW	28480 28480	1854-0404 1854-0404
A1A2R1 A1A2R2 A1A2R3 A1A2R4 A1A2R5	0757-0465 0757-0420 2100-1702 0698-3446 0757-0442	6 3 7 3 9	1 1 1 1 3	RESISTOR 100K 1% .125W F TC=0+-100 RESISTOR 750 1% .125W F TC=0+-100 RESISTOR-TRMR 100 10% WW SIDE-ADJ 20-TRN RESISTOR 383 1% .125W F TC=0+-100 RESISTOR 10K 1% .125W F TC=0+-100	24546 24546 02660 24546 24546	C4-1/8-T0-1003-F C4-1/8-T0-751-F 3810P-101 C4-1/8-T0-383R-F C4-1/8-T0-1002-F
A1A2R6 A1A2R7 A1A2R8 A1A2R9 A1A2R10	0698-3260 0698-3457 0698-3439 0757-0442 0757-0416	9 6 4 9 7	1 1 1 1 1	RESISTOR 464K 1% .125W F TC=0+-100 RESISTOR 316K 1% .125W F TC=0+-100 RESISTOR 178 1% .125W F TC=0+-100 RESISTOR 10K 1% .125W F TC=0+-100 RESISTOR 511 1% .125W F TC=0+-100	28480 28480 24546 24546 24546	0698-3260 0698-3457 C4-1/8-T0-178R-F C4-1/8-T0-1002-F C4-1/8-T0-511R-F
A1A2R11 A1A2R12 A1A2R13 A1A2R14	0757-0442 0757-0458 0757-0458 0757-0317	9 7 7 7	1 2 1	RESISTOR 10K 1% .125W F TC=0+-100 RESISTOR 51.1K 1% .125W F TC=0+-100 RESISTOR 51.1K 1% .125W F TC=0+-100 RESISTOR 1.33K 1% .125W F TC=0+-100	24546 24546 24546 24546	C4-1/8-T0-1002-F C4-1/8-T0-5112-F C4-1/8-T0-5112-F C4-1/8-T0-1331-F
A1A2TP1 A1A2TP2 A1A2TP3 A1A2TP4 A1A2TP5	0360-0535 0360-0535 0360-0535 0360-0124 0360-0124	0 0 0 3 3	3 7	TERMINAL TEST POINT PCB TERMINAL TEST POINT PCB TERMINAL TEST POINT PCB CONNECTOR-SGL CONT PIN .04-IN-BSC-SZ RND CONNECTOR-SGL CONT PIN .04-IN-BSC-SZ RND	00000 00000 00000 28480 28480	ORDER BY DESCRIPTION ORDER BY DESCRIPTION ORDER BY DESCRIPTION 0360-0124 0360-0124
A1A2TP6 A1A2TP7 A1A2TP8 A1A2TP9 A1A2TP10	0360-0124 0360-0124 0360-0124 0360-0124 0360-0124	3 3 3 3 3	3	CONNECTOR-SGL CONT PIN .04-IN-BSC-SZ RND CONNECTOR-SGL CONT PIN .04-IN-BSC-SZ RND CONNECTOR-SGL CONT PIN .04-IN-BSC-SZ RND CONNECTOR-SGL CONT PIN .04-IN-BSC-SZ RND CONNECTOR-SGL CONT PIN .04-IN-BSC-SZ RND	28480 28480 28480 28480 28480	0360-0124 0360-0124 0360-0124 0360-0124 0360-0124
A1A2U1 A1A2U2 A1A2U3 A1A2U4	1826-0431 1858-0047 1820-1413 1810-0346	4 5 2 7	1 1 1 1	IC CONV 24-DIP-C PKG TRANSISTOR ARRAY 16-PIN PLSTC DIP IC CDCR CMOS BCD-TO-7-SEG 4-TO-7-LINE NETWORK-RES 16-DIP180.0 OHM X 8	04713 13606 3L585 11236	MC14433L ULN-2003A CD4511BE 761-3-R180
A1A2VR1 A1A2VR2	1902-0064	1	1	NOT ASSIGNED DIODE-ZNR 7.5V 5% DO-35 PD=.4W TC=+.05%	28480	1902-0064

*Indicates factory selected value

A1A2
DPM DRIVER
08558-60125

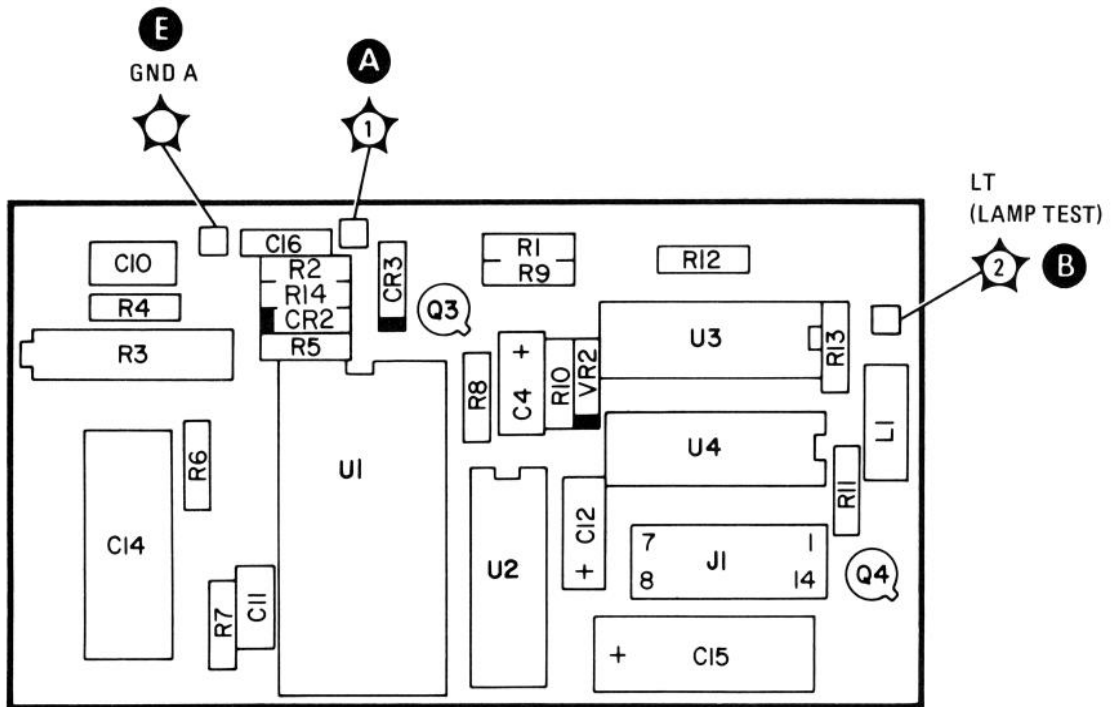

FIGURE 8-10. A1A2 DPM DRIVER, COMPONENT LOCATIONS

A2 FRONT SWITCH ASSEMBLY, CIRCUIT DESCRIPTION

Functions of the switches and potentiometers on the Front Switch Assembly A2 and the Front Switch Board Assembly A2A1 are covered in the circuit descriptions for the electronic assemblies they control. Disassembly and repair procedures for the Front Switch Assembly are included in the following pages.

FRONT SWITCH ASSEMBLY A2 DISASSEMBLY AND REPAIR

TABLE 8-4. TOOLS AND MATERIALS REQUIRED

Description	HP Part Number	Check Digit
No. 2 Spline (Bristol) Wrench	8710-0055	0
Long No. 4 Hex (Allen) Wrench	5020-0288	5
Long No. 6 Hex (Allen) Wrench	5020-0289	6
13/64-inch Open-end Wrench	8710-0946	8
5/16-inch Open-end Wrench	8720-0015	3
3/8-inch Open-end Wrench	8720-0016	4
1/2-inch Open-end Wrench	8720-0025	5
5/8-inch Open-end Wrench	8720-0010	8
1/4-inch Nut Driver	8720-0002	8
5/16-inch Nut Driver	8720-0003	9
3/8-inch Nut Driver	8720-0005	1
1/2-inch Nut Driver (end covered with heatshrink tubing)	8720-0007	3
9/16-inch Nut Driver (drilled out, end covered with heatshrink tubing)	8720-0008	4
Pozi-drive Screwdriver	8710-0899	0
Long-nose Pliers	8710-0030	1
Wire Cutters	8710-0012	9
Instrument Grease	6040-0584	7
Tiewraps	1400-0249	0
Small Brush (for Grease Application)	8520-0015	9
Isopropyl Alcohol/Distilled Water Mixture (50%-50%, for use as cleaning solvent)		

REMOVAL OF FRONT SWITCH ASSEMBLY FROM HP 8558B CHASSIS

1. Turn the HP 8558B upside down on a flat work surface.

NOTE

Numbers in parentheses match the numerical callouts on Figure 8-18, Front Switch Assembly (exploded view). Unless otherwise indicated, all other illustrations referenced in these procedures follow the last procedural step.

2. Use a 9/16-inch nut driver (drilled out, if necessary, to fit over front panel BNC connectors, and covered with heatshrink tubing or tape to avoid scratching the enameled front panel) to remove two dress nuts holding 1ST LO OUTPUT and CAL OUTPUT connectors to the front panel.
3. Use a 5/16-inch open-end wrench to carefully disconnect the semi-rigid Cable W14 from RF Input Limiter U1 (cable connects Limiter to Input Attenuator A3).
4. Cut the plastic tiewrap holding the brown CAL OUTPUT Cable W8 to the Front Switch Standoff (69).
5. Disconnect the 50-conductor Ribbon Cable A2A1W3 (53) from the Motherboard Assembly A16.

6. Turn the HP 8558B right-side up, with the front panel facing you.
7. Disconnect the 14-conductor Ribbon Cable A2A1W1 (52) from the DPM Driver Assembly A1A2. Fold the cable up and away from the board.
8. Remove the four Screws (19) attaching DPM Driver Assembly A1A2 to the DPM Mounting Brackets (20, 21).
9. Disconnect four wires (0, 916, 918, 923) from the upper right corner of the Front Switch Board Assembly A2A1 (next to FREQUENCY ZERO potentiometer).
10. Remove the four screws attaching the Front Switch Diecast (1) to the left and right side gussets. Remove Front Switch Assembly A2, with Front Panel and RF Input Attenuator A3, from the HP 8558B chassis and set the chassis to one side.

DISASSEMBLY OF THE FRONT SWITCH ASSEMBLY

NOTE

It is not necessary to remove the front panel, all connectors, and all knobs to service Front Switch Board Assembly A2A1 (steps 11-24).

11. Remove the following front panel knobs using a no. 4 hex (Allen) wrench: FINE TUNE, COARSE TUNE, RESOLUTION BW, FREQ SPAN/DIV, REF LEVEL FINE, and REFERENCE LEVEL (including Index Disc, Retaining Clip, Nylon Spacer Washer(s), Conical Spring, and Input Attenuator pointer).
12. Remove VIDEO FILTER and BASELINE CLIPPER knobs using a no. 2 spline (Bristol) wrench.
13. Remove the dress nut on the FREQUENCY CAL pushbutton using a 13/64-inch open-end wrench.
14. Remove the front panel hex nut and lockwasher on the Coarse Tune Bushing (42) using a 1/2-inch nut driver (covered with heatshrink tubing or tape to avoid scratching the enameled front panel).
15. Remove Retaining Clip (25) from the RESOLUTION BW Shaft (61).
16. Place the Front Switch Assembly on a flat working surface with the remaining knobs face-down and the lock mechanism facing you. Prop the sides of the switch assembly to allow the knobs and shafts to clear the working surface (be careful not to scratch front panel enamel).
17. Loosen the hex nut attaching RF Input Cable Assembly W1 to the Front Switch Assembly using a 5/8-inch open-end wrench (*Options 001 and 002: Loosen the front panel dress nut with the special 9/16-inch nut driver*). Carefully disconnect the input cable assembly from the RF Input Attenuator A3, using a 5/16-inch open-end wrench. Remove the input cable assembly from the Front Switch Assembly.
18. Remove the Screw (19) and Washer (56) attaching the Attenuator Bracket (55) to the Front Switch Diecast (1). Remove the RF Input Attenuator A3 from the Front Switch Assembly.
19. Disassembly of REFERENCE LEVEL Switch:
 - a. Cut the tiwrap holding the REF LEVEL FINE wires to the Standoff (69).
 - b. Remove the three Screws (54) attaching the Ref Level Fine Pot Plate (75) to the Standoffs (69).
 - c. Remove the Index Disc Locator and the Ref Level Fine Assembly (35, 36, and 71 through 76) from the Front Switch Assembly (set to one side, without detaching wires).

- d. Remove the three Standoffs (69) used to support the Ref Level Fine Pot Plate (75). Use a no. 6 hex wrench to loosen the two set screws on the Miter Gear (57) attached to the Attenuator Shaft Assembly (17); then remove the Miter Gear from the shaft.
- e. Use a no. 4 hex wrench to loosen the Rotating Lockout (70) attached to the Ref Level Shaft (6), and remove the lockout from the shaft. Remove the Ref Level Detent (68) from the Front Switch Assembly. Be careful to keep the Ball Bearing (10) and Spring (11) with the Ref Level Rotor (67).
- f. Remove the three Studs (59) used to support the Ref Level Detent (68).
- g. Use a no. 4 hex wrench to loosen the two set screws on front Anticrush Drive Hub Assembly (7) (between Front Switch Board A2A1 and Front Switch Diecast (1) on Ref Level Shaft (6); accessible from side of Front Switch Assembly). Remove the Ref Level Rotor (67) and Ref Level Shaft (6) with the rear Anticrush Drive Hub Assembly (7) still attached.

NOTE

Rear Anticrush Drive Hub Assembly (7) on Ref Level Shaft (6) is preset at 9.525 mm (0.3 in.) from end of shaft (see Figure 8-12A). Do not remove drive hub unless necessary for repair.

20. Disassembly of RESOLUTION BW Switch.
 - a. Use a 1/4-inch Nut Driver to remove the two Hex Nuts (22) attaching Bandwidth Switch Board (80) to the Front Switch Assembly, and set the board to one side (without detaching wires).
 - b. Remove the Bandwidth Rotor (63). Be careful to keep the Ball Bearings (10) and Springs (62) with the rotor.
 - c. Remove the Bandwidth Shaft (61), with the rear Drive Hub (14) still attached, from the Front Switch Assembly.

NOTE

Rear Drive Hub (14) on Bandwidth Shaft (61) is preset flush with the collar on the shaft (see Figure 8-12B). Do not remove drive hub unless necessary for repair.

- d. Use a no. 4 hex wrench to loosen the two screws on the Coupling Hub (60), attached to the Frequency Span Shaft (9), and remove the hub from the shaft.
 - e. Remove the two Studs (59, 78) used to support the Bandwidth Switch Board (80). Remove the Bandwidth Detent (58) from the Front Switch Assembly.
21. Disconnect the Probe Power wires (0, 92, 97) from the Front Switch Board Assembly A2A1.
 22. Remove the Screw (23) and Spacer (24) attaching the Front Switch Board Assembly A2A1 to the Front Switch Diecast (1). It is located above the DPM Display.
 23. Remove the three remaining Screws (54) attaching the Front Switch Board Assembly A2A1 to the Front Switch Diecast (1).
 24. Twist the left side of the Front Switch Board Assembly A2A1 down approximately 1/8-inch to provide clearance from the Front Switch Diecast support arm (upper left corner). Lift the Front Switch Board Assembly A2A1 from the Front Switch Diecast (1) and set aside.

25. Removal of Rotor Assemblies:

- a. Remove the Attenuator Drive Rotor (8), front the Anticrush Drive Hub Assembly (7), and the Attenuator Shaft Assembly (17) from the Front Switch Diecast (1), and set these parts aside.
- b. Remove the Frequency Span Rotor (13) with associated parts (9-12, 14-16) from the Front Switch Diecast (1), and set aside. Be careful to keep the Ball Bearings (10) and Springs (11) with Frequency Span Rotor (13).

NOTE

Drive Hub (14) on Frequency Span Shaft (9) is preset at 12.954 mm (0.510 in.) from end of shaft (see Figure 8-12C). Do not remove drive hub from shaft unless necessary for repair.

- c. Remove the SWEEP TRIGGER, MANUAL SWEEP, and SWEEP TIME/DIV knobs using a no. 4 hex wrench.
 - d. Remove both the remaining rotor assemblies from the Front Switch Diecast (1), and set aside. Be careful to keep the Ball Bearings (10) and Springs (27) with their respective rotors.
26. Use a no. 4 hex wrench to loosen the two set screws in the Lock Knob. Remove the Lock Knob.
27. Use a 5/16-inch nut driver to remove the two nuts attaching the front panel to the Front Switch Diecast (1). Remove the front panel from the Front Switch Diecast.
28. Disassembly of Lock:
- a. Press the Locking Link (5) into the Front Switch Diecast (1) to release pressure on the Dowel Pin (4). Remove the Dowel Pin through the cutout in the Front Switch Diecast. (Individual parts are identified in Figure 8-14.)
 - b. Remove the Locking Link (5), Locking Shaft (3), and Lock Spring (2) from the Front Switch Diecast.

CLEANING AND INSPECTION OF THE FRONT SWITCH ASSEMBLY

1. All switch contacts must be totally clean and grease-free for proper operation. Use a 50-50 mixture of isopropyl alcohol and distilled water to thoroughly clean the switch rotor contacts and the Front Switch Board Assembly A2A1. Avoid touching the contacts with your fingers.
2. Inspect for bent or damaged shafts, worn or broken contacts, weak or broken springs, rough-feeling potentiometers, cracked castings, and damaged PC boards. Check for signs of corrosion or rust. Replace any suspect parts.
3. A special Instrument Grease, (see list of Tools and Materials at the beginning of these procedures) is recommended exclusively for use during switch reassembly. Lubrication is essential for proper operation of switches and lock. A small brush is recommended for applying the Instrument Grease.

CAUTION

Misapplied grease might cause intermittent switch connections. Utmost care must be taken during reassembly to avoid excessive application of grease and contamination of switch contacts. Avoid getting grease on fingers.

ASSEMBLY OF THE FRONT SWITCH ASSEMBLY

1. Assembly of Lock:
 - a. Lightly grease Locking Shaft (3) and insert into the Front Switch Diecast (1). Lightly grease the bearing surfaces of Locking Link (5).
 - b. Insert the Lock Spring (2) into the Front Switch Diecast (1). Press the Locking Link (5) fully into the Front Switch Diecast and insert the Pin (4) through the access cutout (left side of lock boss) to hold lock mechanism in place. Check for correct lock operation.

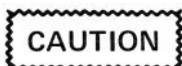

Pressed-in mounting studs on front panel will break if overtightened.

2. Use a 5/16-inch nut driver and two hex nuts to carefully install the front panel (with pushbutton bezels and DPM window installed) on the Front Switch Diecast (1).
3. Use a no. 4 hex (Allen) wrench to install the Lock Knob on the Locking Shaft (3). The base of the Lock Knob should clear the front panel when the Locking Shaft is pushed in.
4. Installation of Rotor Assemblies:
 - a. Lightly grease all switch rotor detent holes on the back of the Front Switch Diecast (1).
 - b. Place the Front Switch Assembly on a flat working surface with the front panel face-down and the lock mechanism facing you. Prop the sides of the switch assembly to provide clearance for knobs and shafts during assembly (be careful not to scratch front panel enamel).
 - c. Inspect the SWEEP TRIGGER rotor assembly (10, 12, 27-31). The Stop Arm (30) and Horseshoe Spring (31) are held in position by Push-on Retainer (29) and should move smoothly without binding (see Figure 8-13A). Roll Pins (12) should be positioned in hole 7 and hole 18 on the SWEEP TRIGGER Rotor (28). Check that the Spring (27) and Ball Bearing (10) are in position.
 - d. Lightly grease the long side of the SWEEP TRIGGER Shaft (28) and insert the SWEEP TRIGGER rotor assembly into the left-most bushing in the Front Switch Diecast (1). Position the rotor so that the Ball Bearing (10) aligns with the stop boss on the left side of the Front Switch Diecast (see Figure 8-15).
 - e. Inspect the SWEEP TIME/DIV rotor assembly (10, 25-28), Figure 8-13B. The MANUAL SWEEP Shaft (26) should be lightly greased and should turn freely inside the SWEEP TIME/DIV Shaft (28). Check that the Spring (27) and Ball Bearing (10) are in position. Note that there are no roll pins inserted in the SWEEP TIME/DIV Rotor (28).
 - f. Lightly grease the long side of the SWEEP TIME/DIV Shaft (28) and insert the SWEEP TIME/DIV rotor assembly into the next bushing in Front Switch Diecast (1) (see Figure 8-15).
 - g. Inspect the FREQ SPAN/DIV rotor assembly (9-16). If the Drive Hub (14) has been loosened or removed from the Frequency Span Shaft (9), refer to Figure 8-13C for the correct dimensions for adjustment. Roll Pins (12) should be positioned in hole 1 and hole 16 on Frequency Span Rotor (13), as shown in Figure 8-13C. The Slotted Bushing (15), Hairpin Spring (16), and the Frequency Span Shaft must be lightly greased where they contact each other for proper operation of push-pull mechanism. Check that the Springs(11), Ball Bearings (10), Slotted Bushing, and the Hairpin Spring are in the correct position.

- h. Lightly grease the long side of the Frequency Span Shaft (9) and insert the **FREQ SPAN/DIV** rotor assembly (9-16) into the next bushing in the Front Switch Diecast (1). Position the **FREQ SPAN/DIV** rotor assembly so that the stop boss on the Front Switch Diecast does not fall within the small span between Roll Pins (12), as shown in Figure 8-15.
- i. Inspect the Attenuator Drive Rotor (8). The Roll Pins (12) should be positioned in hole 1 and hole 9, as shown in Figure 8-13D.
- j. Inspect the front Anticrush Drive Hub Assembly (7). Note that the pin is offset to one side of the drive hub; place the drive hub over the right-most bushing in the Front Switch Diecast (1) with this side down (i.e., pin as close as possible to Front Switch Diecast) for proper switch operation.

NOTE

Correct side of front Anticrush Drive Hub (7) must be oriented towards Front Switch Diecast (1) for proper operation of Front Switch Assembly.

- k. Set the Attenuator Drive Rotor (8) over the Anticrush Drive Hub (7) with the Attenuator Drive Rotor gear facing up. The long pin on the Attenuator Drive Rotor should protrude through the curved slot in the diecast.
 - l. Lightly grease the gear end of the Attenuator Shaft Assembly (17) and insert into the Front Switch Diecast (1) as shown in Figure 8-15. Place the metal Washer (18) on the shaft.
 - m. Clean the contact fingers on all the rotors using a lint-free cloth and a mixture of isopropyl alcohol/distilled water. All rotors should be in proper position as shown in Figure 8-15.
5. Installation of Front Switch Board Assembly A2A1:
- a. Inspect the Front Switch Board Assembly. Check the switch traces for dirt, grease, or wear. Check the interconnect wires, solder joints, pushbutton switches, and ribbon cables (52, 53).
 - b. Clean the switch traces using a lint-free cloth and a mixture of isopropyl alcohol/distilled water. No residue should be visible on the traces.
 - c. Use a 1/4-inch nut driver to tighten the Hex Nuts (22) and Screws (19) used to fasten the DPM Mounting Brackets (20, 21) to the Front Switch Board Assembly.
 - d. Use a 3/8-inch open-end wrench to tighten the Hex Nut (36) and Lockwasher (35) attaching **FREQUENCY ZERO** Potentiometer (37) to the Front Switch Board Assembly. Use a no. 2 spline (Bristol) wrench to install the **FREQUENCY ZERO** Knob (34).
 - e. Use a 3/8-inch open-end wrench to tighten the Hex Nut (36) and Lockwasher (35) attaching the **VIDEO FILTER** Potentiometer (39) and metal Washer (38) to the Front Switch Board Assembly.
 - f. Use a 1/2-inch open-end wrench to tighten the inner Hex Nut (32) and Washer (33) attaching the Dual Tune Pot assembly (25, 32, 33, 40-48,50) to the Front Switch Board Assembly. Note that the Roll Pin (12) aligns with the hole in the switch board to locate the Dual Pot Bracket (45); The washer (33) between the bracket and switch board is critical to proper switch operation. See Figure 8-16 for a front view of the assembled switch board.
 - g. Check the Dual Tune Pot assembly for smooth operation and proper gear meshing; disassemble and lightly grease the shafts if necessary. Install the second Hex Nut (32) mid-way onto the Coarse Tune Shaft Bushing (42).

- h. Set the Front Switch Board Assembly into place on the partially-assembled Front Switch Assembly and use a Stud (59) on the right-most side of the switch assembly to loosely fasten the switch board to the Front Switch Diecast (1).
- i. With one Stud (59) in place but not tight, twist the left side of the Front Switch Board Assembly up approximately 1/8-inch to fasten the switch board under the Front Switch Diecast support arm (upper left corner) and align the switch shafts.
- j. Loosely install the three remaining Screws (54) used to fasten the Front Switch Board Assembly to the Front Switch Diecast (1).
- k. Use a no. 4 hex wrench to temporarily install the SWEEP TRIGGER, SWEEP TIME/DIV, MANUAL SWEEP, AND FREQ SPAN/DIV knobs. Insert the FREQUENCY CAL pushbutton through the front panel and fasten with a dress nut. Use a 13/64-inch open-end wrench to tighten the nut to the front panel.

CAUTION

Do not overtighten screws and studs into the Front Switch Diecast (1).

- l. Tighten Stud (59) and left-most Screw (54) attaching the Front Switch Board Assembly to the Front Switch Diecast (1). Check all the switch rotors for smooth, free switch action. Readjust position of Front Switch Board Assembly as necessary for proper switch action.
 - m. Install the Screw (23) and Spacer (24) used to attach the Front Switch Board Assembly to the Front Switch Diecast (1). It is located above the DPM Display.
 - n. Tighten the two remaining Screws (54) attaching the Front Switch Board Assembly to the Front Switch Diecast (1).
 - o. Recheck all switch rotors for smooth, free switch action and readjust the Front Switch Assembly as necessary.
 - p. Connect the PROBE POWER wires (0, 92, 97) to their respective pins on the Front Switch Board Assembly.
6. Assembly of RESOLUTION BW Switch:
- a. Place the Coupler Hub (60) on the Frequency Span Shaft (9) with the pin facing up (away from Front Switch Assembly). Do not tighten the Coupler Hub at this time.
 - b. Center the Bandwidth Detent (58) over the Coupler Hub (60) with the stop tab towards the top of the Front Switch Assembly. Fasten it to the Front Switch Assembly using two Studs (59, 78).
 - c. If the Drive Hub (14) has been removed or loosened from the Bandwidth Shaft (61), refer to Figure 8-12B for proper adjustment. Lightly grease the narrow end of the Bandwidth Shaft (61) and the detent holes on the Bandwidth Detent (58). Insert the Bandwidth Shaft (61) through the Frequency Span Shaft (9).
 - d. Inspect the RESOLUTION BW Rotor (63). Roll Pins (12) should be positioned in hole 1 and hole 18 as shown in Figure 8-13E. Check that the Springs (62) and Ball Bearings (10) are in position.
 - e. Place the RESOLUTION BW Rotor (63) onto the Bandwidth Shaft (61). Position the RESOLUTION BW Rotor assembly so that the stop tab does not fall within the small span between Roll Pins (12).

- f. Clean the contact fingers on the RESOLUTION BW Rotor and switch traces on the Bandwidth Switch Board (80) using a lint-free cloth and a mixture of isopropyl alcohol/distilled water.
- g. Use a 1/4-inch nut driver to fasten the Bandwidth Switch Board (80) to the Front Switch Assembly with two Hex Nuts (22). The end of the Bandwidth Shaft (61) must not bind against the hole in board. Align the MANUAL SWEEP Shaft (26) with the MANUAL SWEEP Potentiometer (77) by turning the MANUAL SWEEP knob clockwise until the shaft engages with the MANUAL SWEEP Potentiometer.

NOTE

If necessary, the depth of the MANUAL SWEEP Shaft (26) can be adjusted by carefully tapping the SWEEPTIME/DIV Shaft (28) farther into the white plastic rotor.

- h. Turn the Front Switch Assembly over and remove the FREQ SPAN/DIV knob using a no. 4 hex wrench.
 - i. Install the Retainer Clip (25) on the Bandwidth Shaft (61).
 - j. Use a no. 4 hex wrench to temporarily install the FREQ SPAN/DIV and RESOLUTION BW knobs.
 - k. Pull and turn the FREQ SPAN/DIV knob until a set screw is visible on the Coupling Hub (60). Push the FREQ SPAN/DIV knob in and out to align the pin on the Coupling Hub with the slots in the Bandwidth Rotor (63). With the FREQ SPAN/DIV knob pushed in and the Coupling Hub flush against the Bandwidth Rotor (pin aligned), tighten the set screw using a no. 4 hex wrench. Turn the FREQ SPAN/DIV knob until the second set screw is visible, and tighten the second set screw.
 - l. Push the FREQ SPAN/DIV knob in and out while observing the Bandwidth Rotor (63). The Bandwidth Rotor will not move if the Coupling Hub (60) is properly aligned. Readjust the Coupling Hub as necessary for proper operation.
7. Assembly of REFERENCE LEVEL Switch:
- a. Install the remaining two Studs (59) on the Front Switch Assembly. Check that all screws and studs have been tightened.
 - b. If the rear Anticrush Drive Hub Assembly (7) has been loosened or removed from the Ref Level Shaft (6), refer to Figure 8-12A for the correct dimensions for adjustment.
 - c. Inspect the Ref Level Rotor (67). The Roll Pins (12) should be positioned in hole 1 and hole 9, as shown in Figure 8-13F. Check that the Spring (11) and Ball Bearing (10) are in position. Insert the Ref Level Shaft (6) through the Ref Level Rotor so that the rear Anticrush Drive Hub (7) seats properly into the rotor.
 - d. Lightly grease the long end of the Ref Level Shaft (6) and insert it through the Front Switch Board Assembly A2A1, the Attenuator Drive Rotor (8), the front Anticrush Drive Hub (7), and the bushing in the Front Switch Diecast (1).
 - e. Lightly grease the detent holes on the flat side of the Ref Level Detent (68). Mount the detent on three Studs (59) and fasten tightly with three Standoffs (69).

CAUTION

Hollow Ref Level Shaft (6) might be damaged if the set screws in the Rotating Lockout (70) are tightened excessively.

- f. Place the Rotating Lockout (70) on the Ref Level Shaft (6) with its teeth flat against the Ref Level Detent (68). The Lockout teeth should be aligned to miss the pin on the Ref Level Detent when the Ref Level Shaft is pushed in (switch in any detent position). With the Ref Level Shaft fully extended from the front panel, use a no. 4 hex wrench to tighten the Rotating Lockout.
 - g. Push the Ref Level Shaft (6) in and out while checking for smooth mechanical feel and proper alignment of the Rotating Lockout (70). The Rotating Lockout should not bind against the Ref Level Detent (68) and should allow the Ref Level Shaft to turn smoothly between detent positions. Adjust the Rotating Lockout as necessary for proper operation.
 - h. Use a no. 4 hex wrench to lightly tighten one set screw in the front Anticrush Drive Hub (7). It should be visible between the Attenuator Drive Rotor (8) and the Front Switch Diecast (1).
 - i. Turn the Attenuator Drive Rotor (8) so that the long pin (for the Input Attenuator pointer) is at the bottom of the Front Switch Diecast (1). Hold The Attenuator Drive Rotor in position and push in on the Ref Level Shaft (6) to align the front Anticrush Drive Hub (7).
 - j. Push the Ref Level Shaft (6) in and out while observing the Ref Level Rotor (67) and the Attenuator Drive Rotor (8). The Rotors will not move when the front Anticrush Drive Hub (7) is properly adjusted.
 - k. Use a no. 4 hex wrench to firmly tighten both set screws in the front Anticrush Drive Hub (7). Recheck the Ref Level Shaft (6) as in step j, and readjust the front Anticrush Drive Hub as necessary.
 - l. Slip the Miter Gear (57) over the Attenuator Shaft Assembly (17). Do not tighten it at this time.
 - m. Inspect the Ref Level Fine Assembly (35, 36, 72-76). The Ref Level Fine Shaft (72) should turn smoothly. Check the Ref Level Fine Potentiometer (76) and its connecting wires for good electrical connections. Lightly grease the Ref Level Fine Shaft and hollow Index Disc Locator (71) shaft.
 - n. Install the Index Disc Locator (71) on the Front Switch Assembly. The hole in the locator bar rides over the left-most Standoff (69) used to support the Ref Level Fine Pot Plate (75). Install the Ref Level Fine Assembly (35, 36, 72-76) on the Front Switch Assembly with three Screws (54). Connecting wires should be routed as shown in Figure 8-17. The Ref Level Fine Shaft (72) should turn smoothly without binding over its full rotation. Adjust the position of the Ref Level Fine Pot Plate as necessary.
 - o. Use a tie-wrap to attach the Ref Level Fine connecting wires to the Standoff (69) as shown in Figure 8-17.
8. Installation of RF Input Attenuator A3:
- a. Mount the RF Input Attenuator to the Attenuator Bracket (55) using two Screws (53). Check all eight attenuator positions by hand for proper detent action and smooth operation. Leave the attenuator in the full counter-clockwise position.
 - b. Slide the Miter Gear (57) to the end of the Attenuator Shaft Assembly (17) against the Ref Level Fine Pot Plate (75). Set the Attenuator Assembly in place on the Front Switch Assembly, with the notch in the Attenuator Bracket (55) lightly greased and aligned with the Attenuator Shaft Assembly. Use a Washer (56) and Screw (19) to fasten the Attenuator Bracket to the lower left corner of the Front Switch Diecast (1). (Do not tighten the Miter Gear at this time.)
 - c. Insert the RF Input Cable Assembly W1 through the front panel and loosely attach it with a hex nut. Carefully connect the cable assembly to the RF Input Attenuator using a 5/16-inch open-end wrench. Tighten the cable assembly to the front panel using a 5/8-inch open-end wrench (*Options 001 and 002: use the special 9/16-inch nut driver to tighten the front panel dress nut*).

NOTE

Front-panel control knobs and their attaching parts are identified in Figure 6-2. Numbers in parentheses match numerical callouts on Figure 8-18.

9. Installation of Knobs:

- a. Turn the SWEEP TRIGGER shaft (28) fully clockwise (as seen from the front of the Front Switch Assembly) to the spring-loaded SINGLE position and release. Use a no. 4 hex wrench to install the SWEEP TRIGGER knob with the SINGLE line aligned with the painted arrow on the front panel. Check for proper switch operation and alignment.
- b. Turn the SWEEP TIME/DIV Shaft (28) to align the Ball Bearing (10) on the SWEEP TIME/DIV Rotor with the leftmost edge of the stop boss on the Front Switch Diecast (1). This positions the SWEEP TIME/DIV Rotor with the Ball Bearing slightly right of the 12 o'clock position (as seen from the front of the Front Panel Assembly). Use a no. 4 hex wrench to lightly tighten the SWEEP TIME/DIV knob onto the SWEEP TIME/DIV Shaft. Be sure to center of green AUTO position with the the painted arrow on the front panel. Turn the SWEEP TIME/DIV knob to any calibrated sweep time position and align the knob markings exactly with the painted arrow on the front panel. Tighten the SWEEP TIME/DIV knob and check for proper switch operation and alignment.
- c. Uncouple the RESOLUTION BW Shaft (61) from the FREQ SPAN/DIV Shaft (9) by pulling both shafts out. Turn each shaft fully clockwise. Use a no. 4 hex wrench to install the FREQ SPAN/DIV knob with 100 MHz indicated. Make sure that the plastic indicator guide on the back of the knob does not completely bottom into the hole in the Front Switch Diecast (1). Install the RESOLUTION BW knob with 3 MHz indicated. Check for the proper operation and alignment of both switches. Push-pull action should be smooth and positive.
- d. Set the nylon shim washer(s) and Index Disc (see Figure 6-2) in place on the REFERENCE LEVEL knob to check for proper shim width. The nylon washers should shim the Index Disc slightly away from the labelled ring on the REFERENCE LEVEL knob to prevent it from rubbing against the painted numbers. Add or remove shim washers as necessary to provide a slight clearance.
- e. Turn the Attenuator Drive Rotor (8) fully counter-clockwise so that the Input Attenuator Pointer guide pin (P/O 8) is at the bottom of the front panel. Turn the Ref Level Shaft (6) fully clockwise. Place the plastic Input Attenuator Pointer over the guide pin (pointer should indicate 70 dB). Place the large end of the conical spring against the Input Attenuator Pointer and slide the REFERENCE LEVEL knob, nylon washer(s), and Index Disc (from step d) onto the Ref Level Shaft. Secure with a retaining clip.
- f. Use a no. 6 hex wrench to adjust the Miter Gears (57) for alignment of the Input Attenuator Pointer with the 70 dB front panel label and proper gear mesh (Input Attenuator A3 still in the full counter-clockwise position).
- g. Turn the REFERENCE LEVEL knob to indicate the level of CAL OUTPUT signal (i.e., -30 dB; *Option 002: +20 dBmV*) and tighten the knob securely with a no. 4 hex wrench. Check for proper operation and alignment of the REFERENCE LEVEL and INPUT ATTEN controls, and readjust the knob, gears, and Rotating Lockout (70) as necessary. The Reference Level should range from -10 dBm to -100 dBm with 0 dB INPUT ATTEN selected (*Option 002: +40 dBmV to -50 dBm*).
- h. Turn the REF LEVEL FINE Shaft (72) fully counter-clockwise and use a no. 4 hex wrench to install the REF LEVEL FINE knob with 0 dB indicated. Check for proper operation and alignment and readjust the knob as necessary.

- i. Turn the **BASELINE CLIPPER** Shaft and the **VIDEO FILTER** Shaft (39) fully counter-clockwise and use a no. 2 spline wrench to install the **BASELINE CLIPPER** and **VIDEO FILTER** knobs in the **OFF** position. Check for proper operation and alignment and readjust as necessary.
- j. Loosely tighten the second Hex Nut (32) on the Coarse Tune Bushing (42) against the Front Switch Diecast (1). Install the front panel nut and washer on the Coarse Tune Bushing and tighten with the special 1/2-inch nut driver.
- k. Use a no. 4 hex wrench to install the **COARSE TUNE** and **FINE TUNE** knobs. The base of the **COARSE TUNE** knob should clear the front panel. Check for proper operation of the **TUNING** control.

INSTALLATION OF FRONT SWITCH ASSEMBLY INTO HP 8558B CHASSIS

10. Set the Front Switch Assembly into place in the chassis, being careful not to bend the semi-rigid cables, pinch the wires, or pinch the ribbon cables. Attach the Front Switch Diecast (1) to the left and right side gussets with four screws.
11. Connect the four wires (0, 916, 918, 923) to their correspondingly-labelled pins in the upper right corner of the Front Switch Board A2A1.
12. Attach the DPM Driver Assembly A1A2 to the DPM Mounting Brackets (20, 21) with four Screws (19).
13. Connect the 14-conductor Ribbon Cable A2A1W1 (52) to the DPM Driver Assembly A1A2.
14. Connect the 50-conductor Ribbon Cable A2A1W2 (53) to the Motherboard Assembly A16.
15. Use a 5/16-inch open-end wrench to carefully connect the Semi-rigid Cable W14 to the RF Input Limiter U1.
16. Use the special 9/16-inch nut driver to install the **CAL OUTPUT** and 1 **ST LO OUTPUT** connectors to the front panel with two dress nuts.
17. Attach the brown **CAL OUTPUT** Cable W8 to the Front Switch Standoff (69) with a tiwrap.
18. Slide the HP 8558B into the display mainframe, turn the instrument **ON**, and verify the proper operation of all controls.

FACTORY PRESET SHAFT ASSEMBLIES

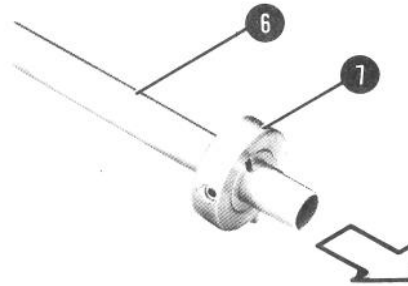

A
REF LEVEL SHAFT

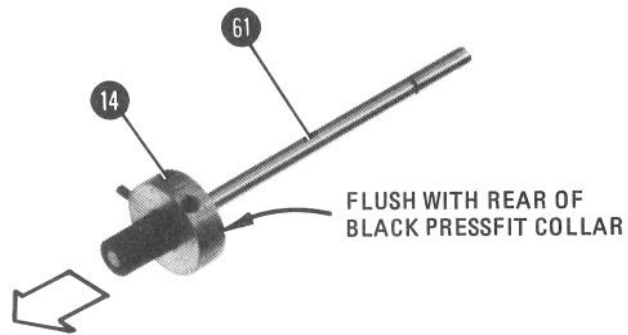

B
BANDWIDTH SHAFT

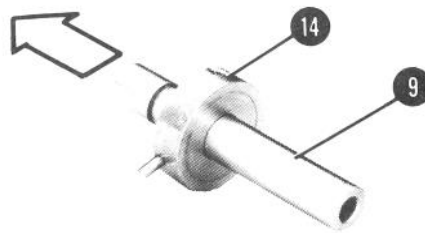

C
FREQUENCY SPAN SHAFT

NOTE

Arrows point toward
rear of HP 8558B.

FIGURE 8-12. SHAFT ASSEMBLIES

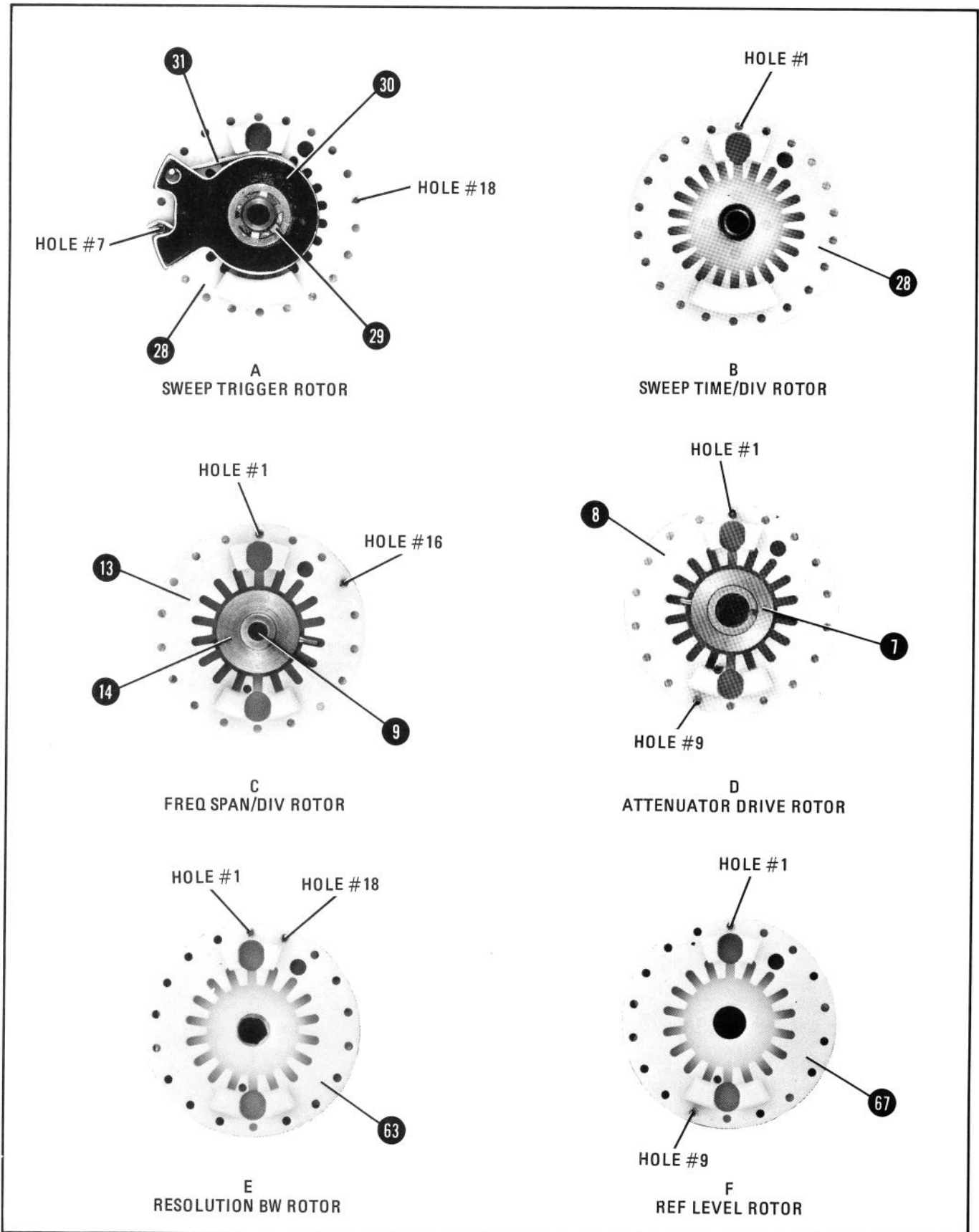

FIGURE 8-13. ROTOR ASSEMBLIES

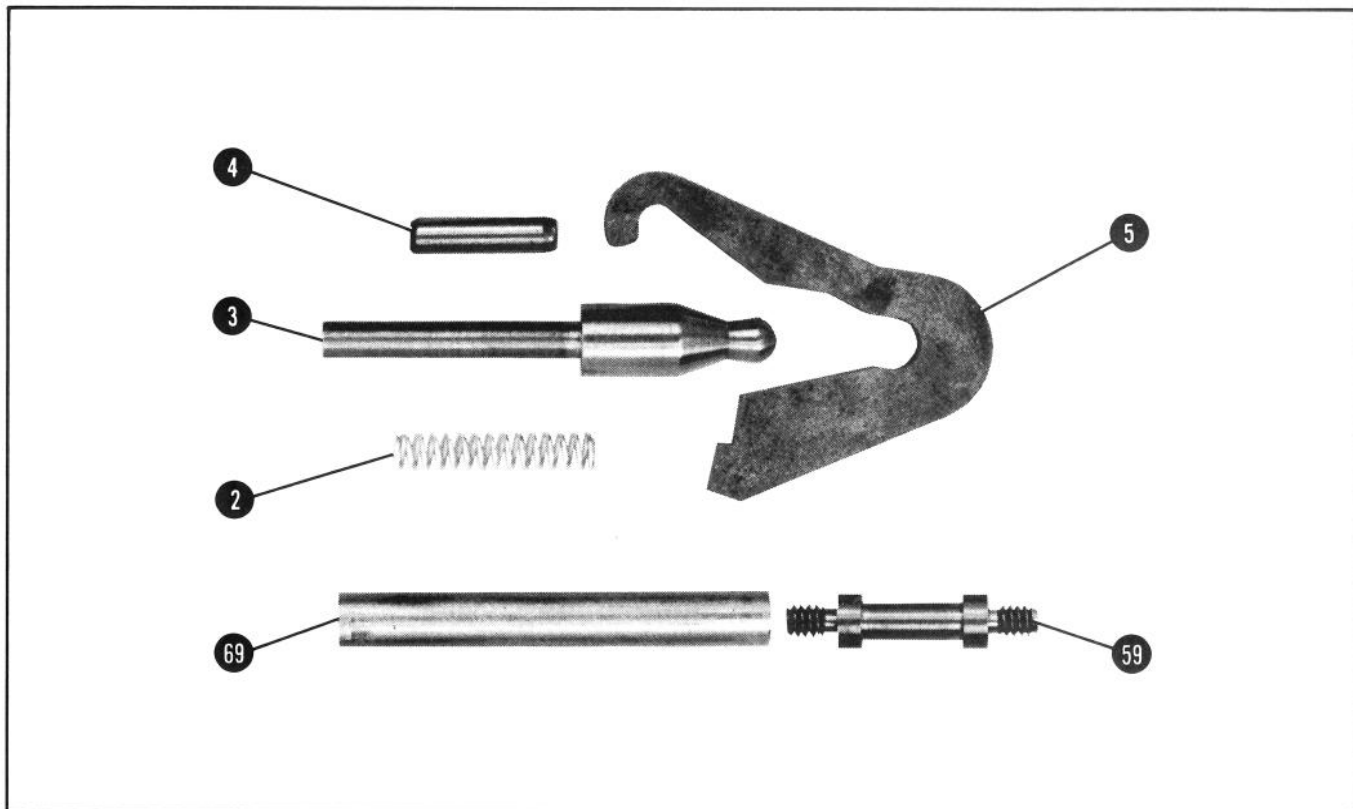

FIGURE 8-14. MACHINED PARTS

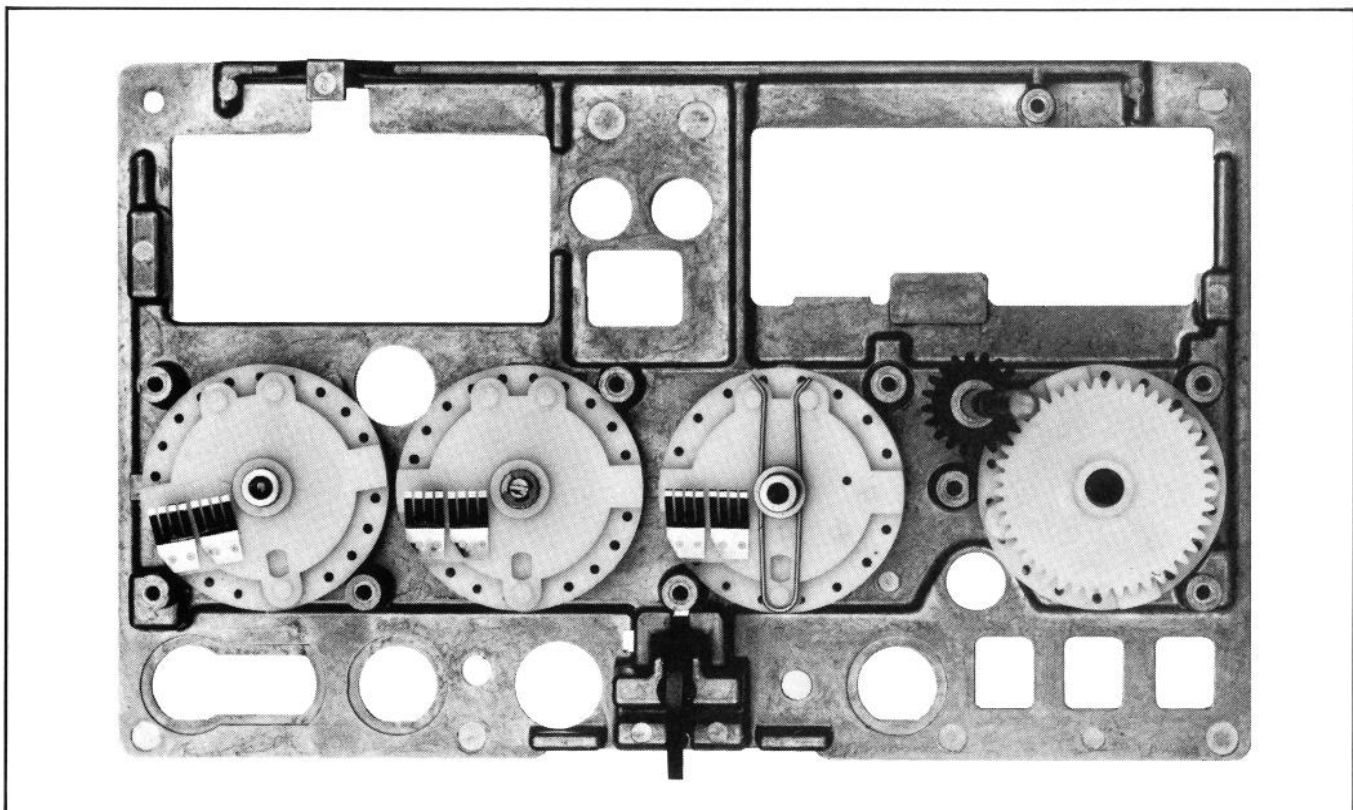

FIGURE 8-15. PROPER POSITIONING OF ROTORS ON FRONT SWITCH DIECAST

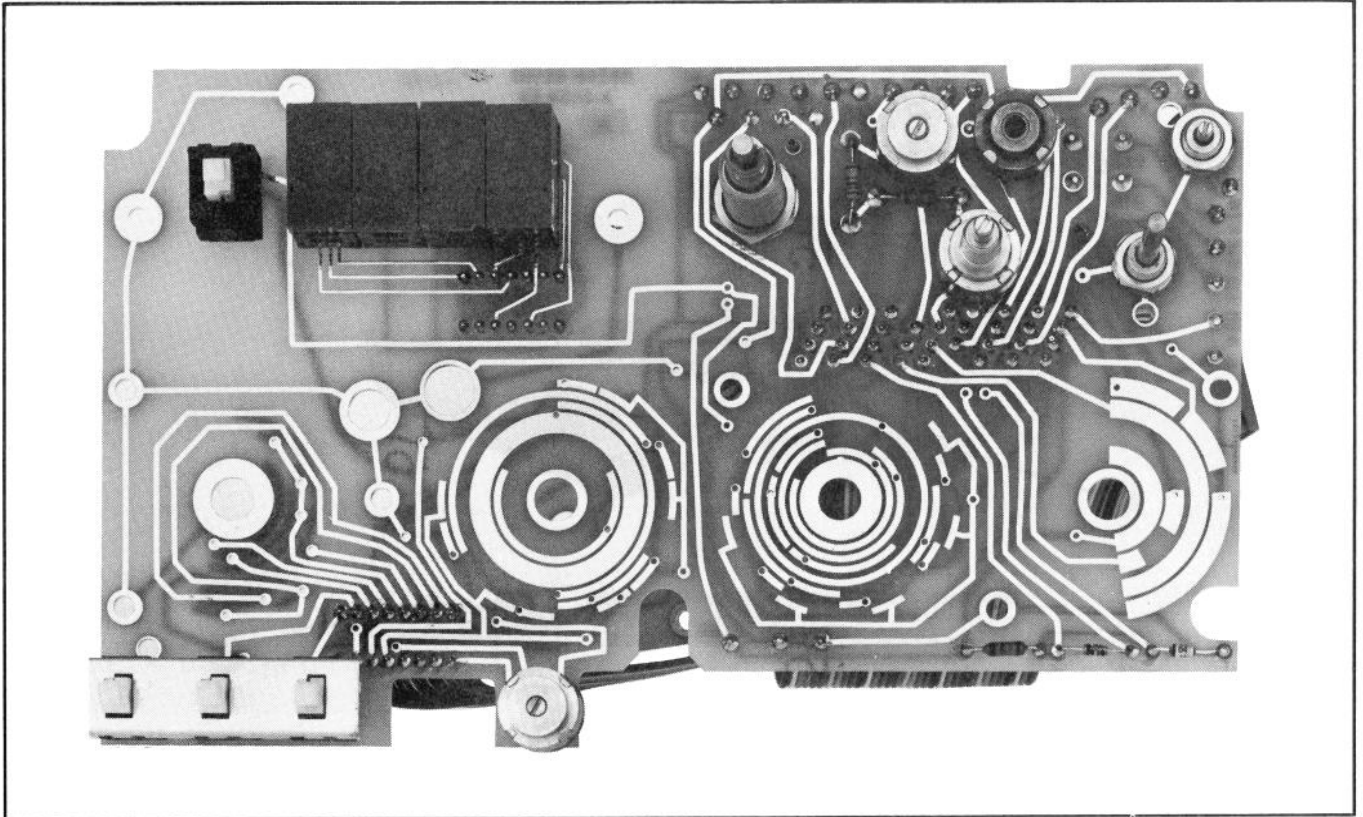

FIGURE 8-16. FRONT VIEW OF SWITCHBOARD ASSEMBLY A2A1

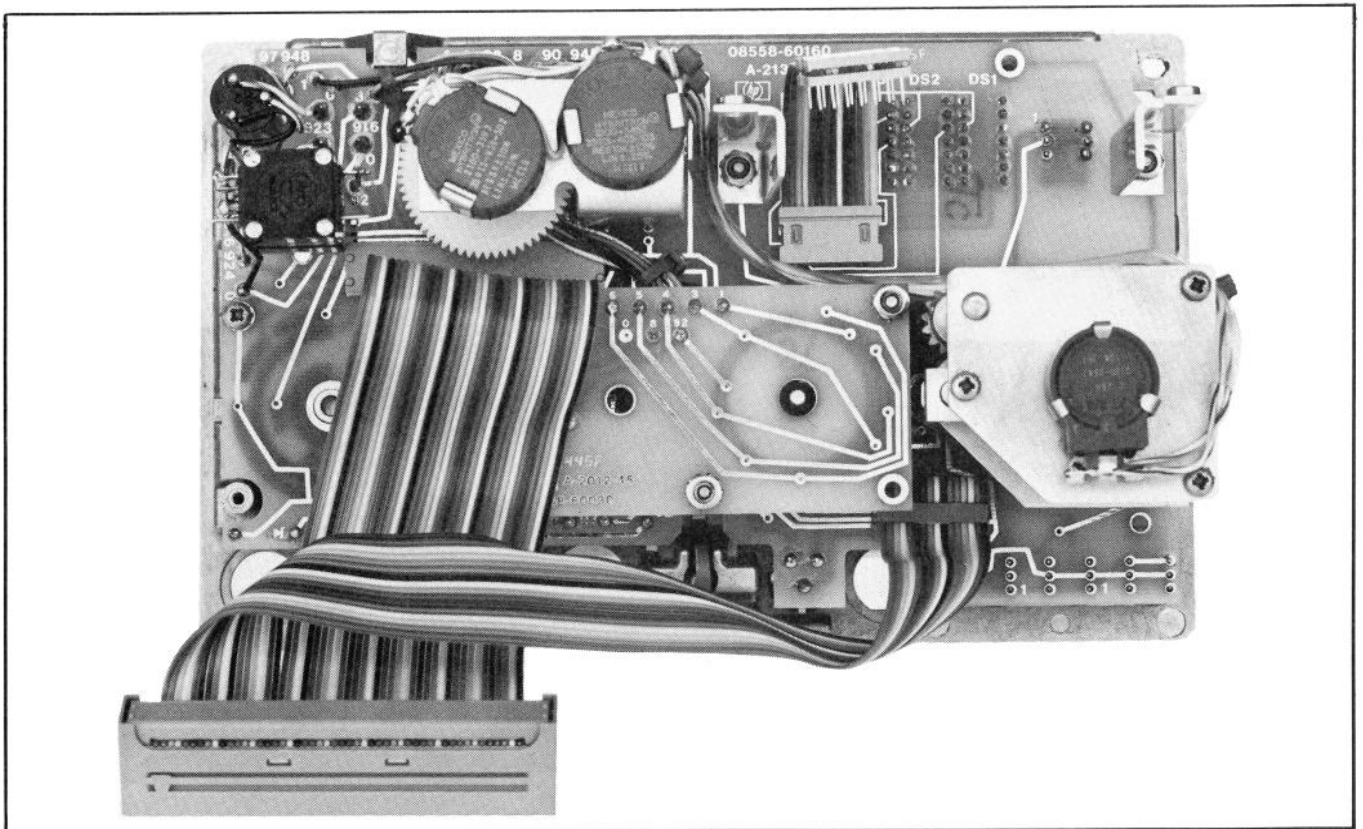

FIGURE 8-17. REAR VIEW OF FRONT SWITCH ASSEMBLY A2

TABLE 8-5. A2 FRONT SWITCH ASSEMBLY, REPLACEABLE PARTS

Reference Designation	HP Part Number	C D	Qty	Description	Mfr Code	Mfr Part Number
A2	08558-60100	2	1	FRONT SWITCH ASSEMBLY (INCLUDES MECH. PARTS LISTED IN FIG 8-18) (SEE FIG 8-18 FOR LOCATION OF THE FOLLOWING ELEC. PARTS)	28480	08558-60100
A2R1	2100-3593	8	1	RESISTOR-VAR PREC W/CP 10-TRN 5K 10% (COARSE TUNE)	28480	2100-3593
A2R2	2100-3452	8	1	RESISTOR-VAR PREC W/CP 10-TRN 10K 10% (FINE TUNE)	28480	2100-3452
A2R3	2100-3066	0	1	RESISTOR-VAR PREC MW 10-TRN 5K 5% (FREQ. ZERO)	28480	2100-3066
A2R4	2100-0542	1	1	RESISTOR-VAR CONTROL MW 10K 5% LIN (RF LVL FINE)	28480	2100-0542
A2R5	2100-4054	8	3	RESISTOR-VARIABLE W/SW 50K +-20%; 10CW (P/O A2R5/R6/S2 VIDEO FILTER)	28480	2100-4054
A2R6	2100-4054	8		RESISTOR-VARIABLE W/SW 50K +-20%; 10CW (P/O A2R5/R6/S2 VIDEO FILTER)	28480	2100-4054
A2S1 A2S2	2100-4054	8		NOT ASSIGNED RESISTOR-VARIABLE W/SW 50K +-20%; 10CW (P/O A2R5/R6/S2 MAX VIDEO FILTER)	28480	2100-4054
A2A1	08558-60160	4	1	FRONT SWITCH BOARD ASSEMBLY	28480	08558-60160
A2A1CR1	1901-0025	2	1	DIODE-GEN PRP 100V 200MA DO-7	28480	1901-0025
A2A1DS1 A2A1DS2 A2A1DS3 A2A1DS4 A2A1DS5	1990-0619 1990-0619 1990-0619 1990-0619 1990-0485	7 7 7 7 5	4	DISPLAY-NUM-SEG 1-CHAR .3-H DISPLAY-NUM-SEG 1-CHAR .3-H DISPLAY-NUM-SEG 1-CHAR .3-H DISPLAY-NUM-SEG 1-CHAR .3-H LED-LAMP LUM-INT=800UCD IF=30MA-MAX	28480 28480 28480 28480 28480	5082-7613 5082-7613 5082-7613 5082-7613 5082-4984
A2A1MP1 A2A1MP2	08558-20030 4040-2135	3 6	1	REAR SWITCH BOARD STDF-LED POLYC	28480 28480	08558-20030 4040-2135
A2A1R1	0757-0447	4	1	RESISTOR 16.2K 1% .125W F TC=0+-100	24546	C4-1/8-T0-1622-F
A2A1R2	2100-3340	3	1	RESISTOR-VAR CONTROL CCP 1K 20% LIN	28480	2100-3340
A2A1R3	2100-2681	3	1	RESISTOR-TRMR 5K 10% CCP TOP-ADJ 1-TRN	28480	2100-2681
A2A1R4	2100-3332	3	1	RESISTOR-TRMR 10K 20% CC TOP-ADJ 1-TRN (MAN. SWEEP)	28480	2100-3332
A2A1R5	0757-0444	1	1	RESISTOR 12.1K 1% .125W F TC=0+-100	24546	C4-1/8-T0-1212-F
A2A1R6	2100-1412	6	1	RESISTOR-TRMR 500 20% CCP TOP-ADJ 1-TRN	28480	2100-1412
A2A1R7	2100-3331	2	1	RESISTOR-TRMR 10K 20% MC TOP-ADJ 1-TRN	28480	2100-3331
A2A1R8	0757-0317	7	1	RESISTOR 1.33K 1% .125W F TC=0+-100	24546	C4-1/8-T0-1331-F
A2A1S1 A2A1S2 A2A1S3-	3101-2213	0	1	NOT ASSIGNED SWITCH-PB 3-STATION 15MM C-C SPACING	28480	3101-2213
A2A1S6 A2A1S7	3101-2124	2	1	NOT ASSIGNED SWITCH-PB DPDT ALTNG .25A 115VAC	28480	3101-2124
A2A1S8	3101-0044	1	1	SWITCH-PB SPST-NO MOM .5A 115VAC RED-BTN	28480	3101-0044
A2A1VR1	1902-0064	1	1	DIODE-ZNR 7.5V 5% DO-35 PD=.4W TC=+.05%	28480	1902-0064
A2A1W1 A2A1W2	08558-60168 08558-60037	2 4	1	RIBBON CABLE ASSY-DPM RIBBON CABLE ASSY-INTERCONNECT	28480 28480	08558-60168 08558-60037
A2A1XDS1 A2A1XDS2 A2A1XDS3 A2A1XDS4	1200-0971 1200-0971 1200-0971 1200-0971	1 1 1 1	4	SOCKET-DSPL 14-CONT DIP DIP-SLDR SOCKET-DSPL 14-CONT DIP DIP-SLDR SOCKET-DSPL 14-CONT DIP DIP-SLDR SOCKET-DSPL 14-CONT DIP DIP-SLDR	28480 28480 28480 28480	1200-0971 1200-0971 1200-0971 1200-0971

*Indicates factory selected value

A2A1
FRONT SWITCH BOARD ASSEMBLY
08558-60160

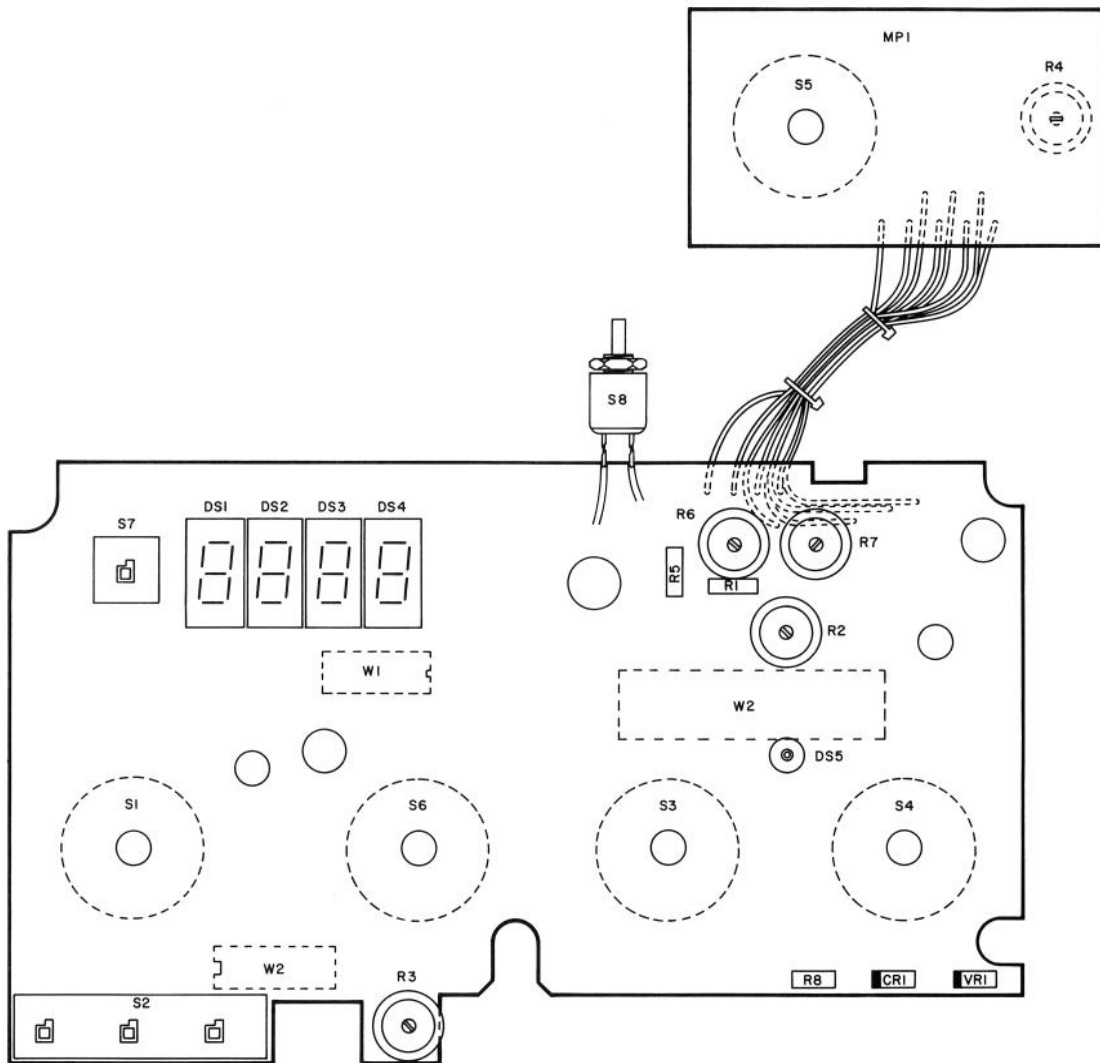

FIGURE 8-19. FRONT SWITCH BOARD ASSEMBLY A2A1, COMPONENT LOCATIONS

A3 U1 A4 A5 A6 CIRCUIT DESCRIPTIONS

A3 Input Attenuator Circuit Description

The 8558B input attenuator (Figure 8-21) is a 50-ohm, precision, coaxial step attenuator. Attenuation in 10 dB steps from 0 dB to 70 dB is accomplished by switching the signal path through one or more of the three resistive pads in a predetermined sequence. (Note that the input attenuator is not field repairable.)

U1, RF Input Limiter Circuit Description

The RF input limiter contains Schottky diodes which clamp the input signal voltage, protecting the mixer diodes in the First Converter Assembly A4. The typical limiting threshold is 1 mW (0 dBm). The limiter is not field serviceable.

A4 First Converter Circuit Description

The RF signal input (0.1 – 1500 MHz) passes through a 1550 MHz low pass filter to the mixer diode assembly, U1. The output impedance of this low-pass filter seen from the mixer is effectively a short circuit at 2050 MHz, reflecting any IF power back to the mixer. The first LO input from YIG Oscillator Assembly A6 passes through a 3 dB power splitter consisting of two resistors, R1 and R2, and etched transmission lines. One of the power splitter outputs provides the front panel LO OUTPUT; the other output is through a balun (short piece of semi-rigid coaxial transmission line) to provide drive voltage to the mixer diodes. The LO signal is coupled to one mixer diode through the balun shield and to the other mixer diode through the balun center conductor. This arrangement splits the LO signal voltage evenly between the two mixer diodes. The 2050 MHz output signal from the mixer (first IF) is split-line coupled to a 6 dB 'pi' resistive matching pad (R3, R4, and R5). A small block of polyiron is placed over the split-output line. The polyiron helps balance the mixer and absorbs harmonics of the mixing signals. A 5000 MHz low-pass filter etched on the A4 printed circuit board provides additional filtering to the 2050 MHz IF signal after the 6 dB pad. The signal is then coupled to Second Converter Assembly A5 through a semi-rigid coaxial cable.

A5 Second Converter Circuit Description

The IF signal from the First Converter is coupled into the Second Converter bandpass filter through coupling loop L3. The bandpass filter consists of three circular, slug-tuned cavity resonators operating as less than a quarter wavelength inductive transmission lines. The cavities provide high 'Q' for good selectivity at 2050 MHz. Coupling loops L4 and L5 provide coupling between the cavities. The 2050 MHz signal is loop coupled to the cathode end of second mixer diode CR1. The second LO signal is loop coupled to the anode end of CR1. The second local oscillator is a Colpitts type circuit operating at 1748.6 MHz. The capacitive 'fingers' etched on the A5A1 printed circuit board and the internal transistor capacitances of A5A1Q1 provide the positive feedback necessary to sustain oscillation. The oscillator tank circuit is a slug-tuned cavity, Z4. The signal from the second LO is coupled into cavity Z4 by a 4 – 40 machine screw extending down into the cavity. The second LO output is also available at test jack A5J3. The 1748.6 MHz local oscillator provides the drive for mixer diode CR1. The difference frequency between the first IF, 2050 MHz, and the second LO frequency, 1748.6 MHz, is 301.4 MHz. This 301.4 MHz signal is coupled through the matching filter to the A10 Second IF. The matching filter is a passive network designed to match the relatively high impedance of the second mixer, about 200 ohms, to the low input impedance of the second IF, about 50 ohms. The match may be optimized by adjusting A5L2, 2nd MIXER MATCH adjustment.

A6 YIG Oscillator Circuit Description

The YIG Oscillator is a transistorized thin-film microcircuit. It uses an yttrium-iron-garnet (YIG) sphere as the frequency determining structure. The YIG sphere is a ferromagnetic material whose resonant frequency is directly proportional to the applied magnetic field. The sphere is placed in the gap of an electromagnet to provide a magnetic tuning structure whose field (and thereby the oscillator's frequency) is linearly proportional to the drive current from Frequency Control Assembly A7.

The main coil is used for wide range sweeping and tuning with the coil current varying from approximately 50 to 8 mA. The FM coil is used only for narrow spans (1 MHz/DIV and less) with the coil current varying from approximately -25 mA to $+25$ mA.

The YIG Oscillator Assembly consists of three parts: a sealed magnet assembly which encloses the YIG sphere and oscillator; a bias board which uses discrete components to establish oscillator/amplifier bias and to protect against supply noise and voltage overloads; and a mu-metal magnetic shielding can.

TABLE 8-6. RF SECTION, REPLACEABLE PARTS (1 OF 2)

Reference Designation	HP Part Number	C D	Qty	Description	Mfr Code	Mfr Part Number
A3	5086-7363	7	1	INPUT ATTENUATOR	28480	5086-7363
	08495-60004	9	1	RESTORED 5086-7363, EXCHANGE REQUIRED	28480	08495-60004
A4	08558-60004	5	1	FIRST CONVERTER ASSEMBLY	28480	08558-60004
A4J1	1250-1796	5	4	CONNECTOR-RF SMA FEM SGL-HOLE-RR 50-OHM	28480	1250-1796
A4J2	1250-1796	5		CONNECTOR-RF SMA FEM SGL-HOLE-RR 50-OHM	28480	1250-1796
A4J3	1250-1796	5		CONNECTOR-RF SMA FEM SGL-HOLE-RR 50-OHM	28480	1250-1796
A4J4	1250-1796	5		CONNECTOR-RF SMA FEM SGL-HOLE-RR 50-OHM	28480	1250-1796
A4MP1	08558-00052	7	1	GASKET 1ST CONV	28480	08558-00052
A4MP2	08558-20042	7	1	COVER 1ST CONVTR	28480	08558-20042
A4MP3	08558-20043	8	1	MOUNT 1ST CONV	28480	08558-20043
A4R1	0698-7212	9	1	RESISTOR 100 1% .05W F TC=0+-100	24546	C3-1/8-T0-100R-F
A4R2	0698-7221	0	1	RESISTOR 237 1% .05W F TC=0+-100	24546	C3-1/8-T0-237R-F
A4R3	0698-7216	3	2	RESISTOR 147 1% .05W F TC=0+-100	24546	C3-1/8-T0-147R-F
A4R4	0698-7202	7	1	RESISTOR 38.3 1% .05W F TC=0+-100	24546	C3-1/8-T0-38R3-F
A4R5	0698-7216	3	1	RESISTOR 147 1% .05W F TC=0+-100	24546	C3-1/8-T0-147R-F
A4U1	08558-20095	0	1	DIODE ASSY	28480	08558-20095
				MISCELLANEOUS		
	2190-0067	4	5	WASHER-LK INTL T 1/4 IN .256-IN-ID	28480	2190-0067
A5	08558-60097	6	1	SECOND CONVERTER	28480	08558-60097
A5C1	0160-3036	8	2	CAPACITOR-FDTHRU 5000PF +80 -20% 200V	28480	0160-3036
A5C2	0160-3036	8		CAPACITOR-FDTHRU 5000PF +80 -20% 200V	28480	0160-3036
A5C3	0160-2436	0	1	CAPACITOR-FDTHRU 10PF 20% 200V CER	28480	0160-2436
A5C4	0140-0075	7	1	CAPACITOR-FDTHRU 22PF 10% 500V MICA	72982	666-053-01A0-220K
A5CR1	1901-0950	2	1	DIODE-SM SIG SCHOTTKY	28480	1901-0950
A5J1	1250-1157	2	1	CONNECTOR-RF SMA FEM THD-HOLE 50-OHM	28480	1250-1157
A5J2	1250-1435	9	1	CONN:RF; 500 OHM; SMC	28480	1250-1435
A5J3	1250-0829	3	1	CONNECTOR-RF SMC M SGL-HOLE-FR 50-OHM	28480	1250-0829
A5L1	9100-2255	4	1	INDUCTOR RF-CH-MLD 470NH 10% .105DX.26LG	28480	9100-2255
A5L2	08558-80009	2	1	COIL 2ND CONV OT	28480	08558-80009
A5L3	08558-00034	5	1	COUPLING LOOP, INPUT	28480	08558-00034
A5L4	08558-00033	4	2	COUPLING LOOP, FILTER	28480	08558-00033
A5L5	08558-00033	4	2	COUPLING LOOP, FILTER	28480	08558-00033
A5MP1	08558-20122	4	1	OSCILLATOR HOUSING/SECOND CONV. COVER MATCHED TO A5MP2; NOT SEPARATELY REPLACEABLE	28480	08558-20122
A5MP2	08558-20178	0	1	CAVITY BLOCK, SECOND CONV. MATCHED TO A5MP1; NOT SEPARATELY REPLACEABLE	28480	08558-20178
A5MP3				NOT ASSIGNED		
A5MP4	08558-20074	5	1	INSULATOR, COUPLING POST	28480	08558-20074
A5MP5	08558-00032	3	1	MOUNTING, MIXER DIODE	28480	08558-00032
A5MP6	08558-20120	2	1	CVR-2ND CONN OSC	28480	08558-20120
A5MP7	3030-0397	6	4	SCREW-SET 10-32 1-IN-LG FLAT-PT BRS	00000	ORDER BY DESCRIPTION
A5MP8	3030-0397	6	6	SCREW-SET 10-32 1-IN-LG FLAT-PT BRS	00000	ORDER BY DESCRIPTION
A5MP9	3030-0397	6	6	SCREW-SET 10-32 1-IN-LG FLAT-PT BRS	00000	ORDER BY DESCRIPTION
A5MP10	3030-0397	6	6	SCREW-SET 10-32 1-IN-LG FLAT-PT BRS	00000	ORDER BY DESCRIPTION
A5MP11	0380-0573	8	1	STANDOFF-HEX .625-IN-LG 10-32THD	00000	ORDER BY DESCRIPTION
A5MP12	3030-0422	8	6	SCREW-SKT HD CAP 0-80 .188-IN-LG SST-302	00000	ORDER BY DESCRIPTION
A5MP13	3030-0422	8	8	SCREW-SKT HD CAP 0-80 .188-IN-LG SST-302	00000	ORDER BY DESCRIPTION
A5MP14	3030-0422	8	8	SCREW-SKT HD CAP 0-80 .188-IN-LG SST-302	00000	ORDER BY DESCRIPTION
A5MP15	3030-0422	8	8	SCREW-SKT HD CAP 0-80 .188-IN-LG SST-302	00000	ORDER BY DESCRIPTION
A5MP16	3030-0422	8	8	SCREW-SKT HD CAP 0-80 .188-IN-LG SST-302	00000	ORDER BY DESCRIPTION
A5MP17	3030-0422	8	8	SCREW-SKT HD CAP 0-80 .188-IN-LG SST-302	00000	ORDER BY DESCRIPTION
A5MP18	2240-0151	0	1	SCREW-MACH 4-40 .75-IN-LG PAN-HD-POZI	00000	ORDER BY DESCRIPTION
A5MP19	2740-0001	3	4	NUT-HEX-DBL-CHAM 10-32-THD .109-IN-THK	00000	ORDER BY DESCRIPTION
A5MP20	2740-0001	3	4	NUT-HEX-DBL-CHAM 10-32-THD .109-IN-THK	00000	ORDER BY DESCRIPTION
A5MP21	2740-0001	3	4	NUT-HEX-DBL-CHAM 10-32-THD .109-IN-THK	00000	ORDER BY DESCRIPTION
A5MP22	2740-0001	3	4	NUT-HEX-DBL-CHAM 10-32-THD .109-IN-THK	00000	ORDER BY DESCRIPTION
A5MP23	08565-20068	6	1	CAP INNER ELEMNT	28480	08565-20068
A5MP24				NOT ASSIGNED		
A5MP25	08565-20092	6	1	CAP DIELECTRIC	28480	08565-20092
A5R1	0757-0346	2	1	RESISTOR 10 1% .125W F TC=0+-100	24546	C4-1/8-T0-10R0-F
				MISCELLANEOUS		

*Indicates factory selected value

TABLE 8-6. RF SECTION, REPLACEABLE PARTS (2 OF 2)

Reference Designation	HP Part Number	C D	Qty	Description	Mfr Code	Mfr Part Number
	0360-0002	6	1	TERMINAL-SLDR LUG PL-MTG FOR-#2-SCR	28480	0360-0002
	0520-0173	2	1	SCREW-MACH 2-56 .188-IN-LG PAN-HD-POZI	00000	ORDER BY DESCRIPTION
	0520-0174	3	2	SCREW-MACH 2-56 .25-IN-LG PAN-HD-POZI	00000	ORDER BY DESCRIPTION
	2190-0067	4	4	WASHER-LK INTL T 1/4 IN .256-IN-ID	28480	2190-0067
	2190-0124	4	3	WASHER-LK INTL T NO. 10 .195-IN-ID	28480	2190-0124
	2190-0572	6	6	WASHER-LK HLCL NO. 0 .062-IN-ID .1-IN-OD	28480	2190-0572
	2200-0103	2	3	SCREW-MACH 4-40 .25-IN-LG PAN-HD-POZI	28480	2200-0103
	2200-0107	6	26	SCREW-MACH 4-40 .375-IN-LG PAN-HD-POZI	00000	ORDER BY DESCRIPTION
	2200-0119	0	8	SCREW-MACH 4-40 1-IN-LG PAN-HD-POZI	00000	ORDER BY DESCRIPTION
	2200-0171	4	1	SCREW-MACH 4-40 .75-IN-LG 82 DEG	00000	ORDER BY DESCRIPTION
	2950-0078	9	1	NUT-HEX-DBL-CHAM 10-32-THD .067-IN-THK	28480	2950-0078
	3050-0003	3	1	WASHER-FL NH NO. 6 .141-IN-ID .375-IN-OD	28480	3050-0003
	3050-0176	1	4	WASHER-FL MTLC NO. 8 .188-IN-ID	28480	3050-0176
A5A1	08558-60028	3	1	SECOND CONVERTER OSCILLATOR	28480	08558-60028
A5A1Q1	5086-4218	7	1	TC21 IN TD-72PKG	28480	5086-4218
A5A1R1	0683-4705	8	1	RESISTOR 47 5% .25W FC TC=-400/+500	01121	CB4705
A5A1R2	0683-2715	6	1	RESISTOR 270 5% .25W FC TC=-400/+600	01121	CB2715
A6	5086-7080	7	1	OSCILLATOR, YIG (DOES NOT INCL. MTG HDW)	28480	5086-7080
	5086-6080	5	1	RESTORED 5086-7080, EXCHANGE REQUIRED	28480	5086-6080
A6MP1	08558-00008	3	2	YIG BKT FRONT	28480	08558-00008
A6MP2	08558-00008	3	1	YIG BKT FRONT	28480	08558-00008
A6MP3	08558-00076	5	1	STRAP OSC	28480	08558-00076
A6MP4	08558-20118	8	1	NOTCHED STANDOFF	28480	08558-20118
A6MP5	08558-20119	9	3	PLN TPPD STANDOFF	28480	08558-20119
A6MP6	08558-20119	9	1	PLN TPPD STANDOFF	28480	08558-20119
A6MP7	08558-20119	9	1	PLN TPPD STANDOFF	28480	08558-20119
				MISCELLANEOUS		
	0520-0136	7	1	SCREW-MACH 2-56 .625-IN-LG PAN-HD-POZI	00000	ORDER BY DESCRIPTION
	2190-0112	0	1	WASHER-LK HLCL NO. 2 .088-IN-ID	28480	2190-0112
	2200-0107	6	1	SCREW-MACH 4-40 .375-IN-LG PAN-HD-POZI	00000	ORDER BY DESCRIPTION
	3050-0098	6	1	WASHER-FL MTLC NO. 2 .094-IN-ID	28480	3050-0098

*Indicates factory selected value

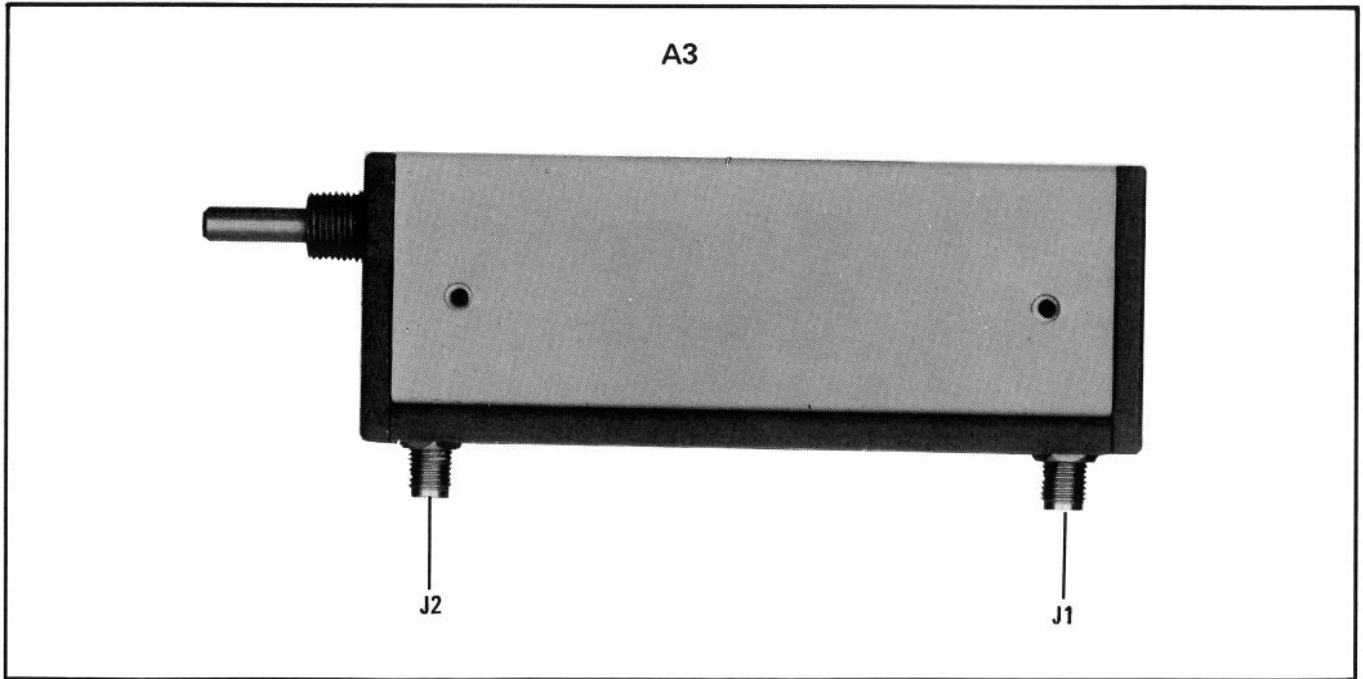

FIGURE 8-21. A3 INPUT ATTENUATOR

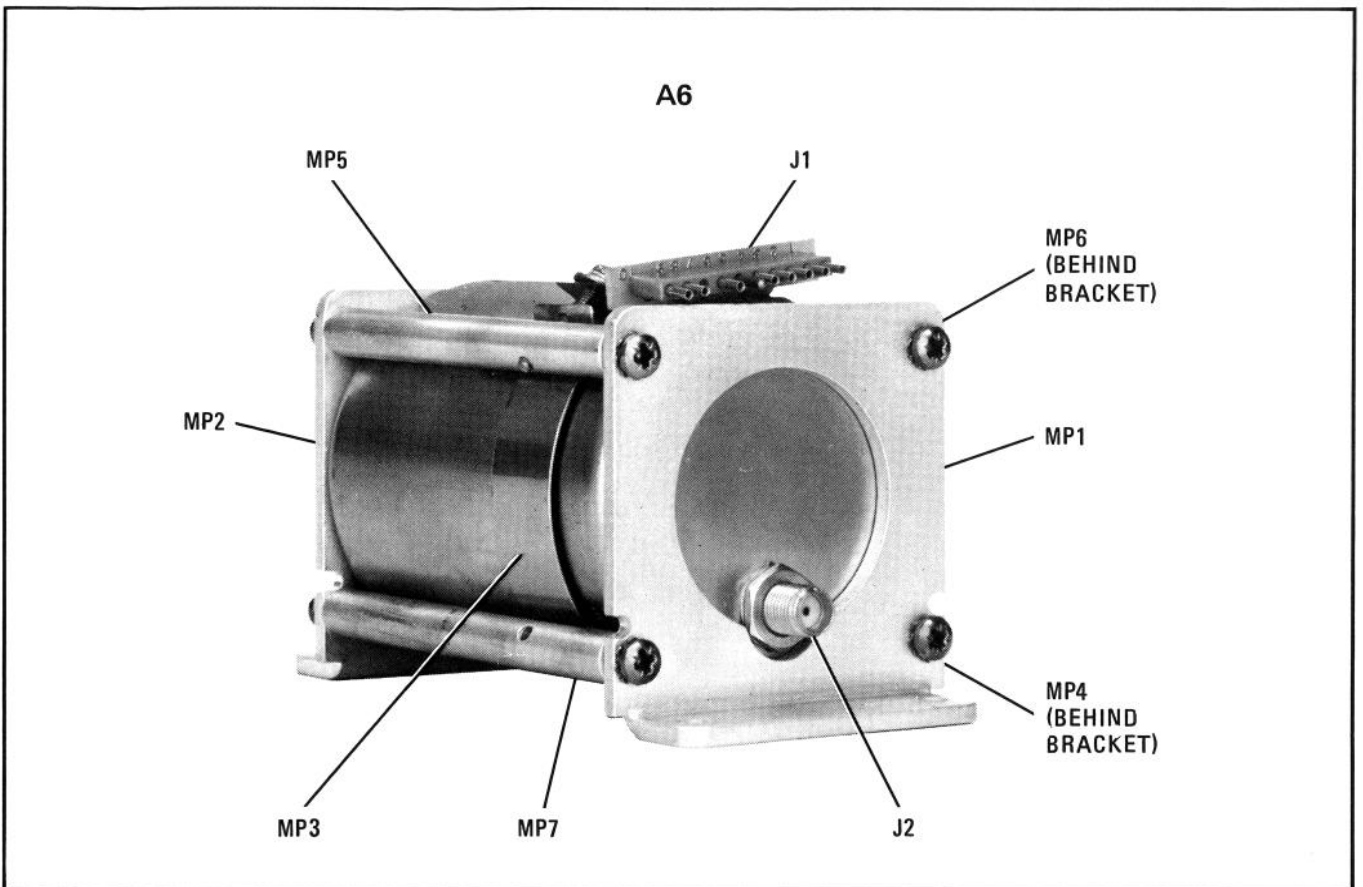

FIGURE 8-22. A6 YIG OSCILLATOR

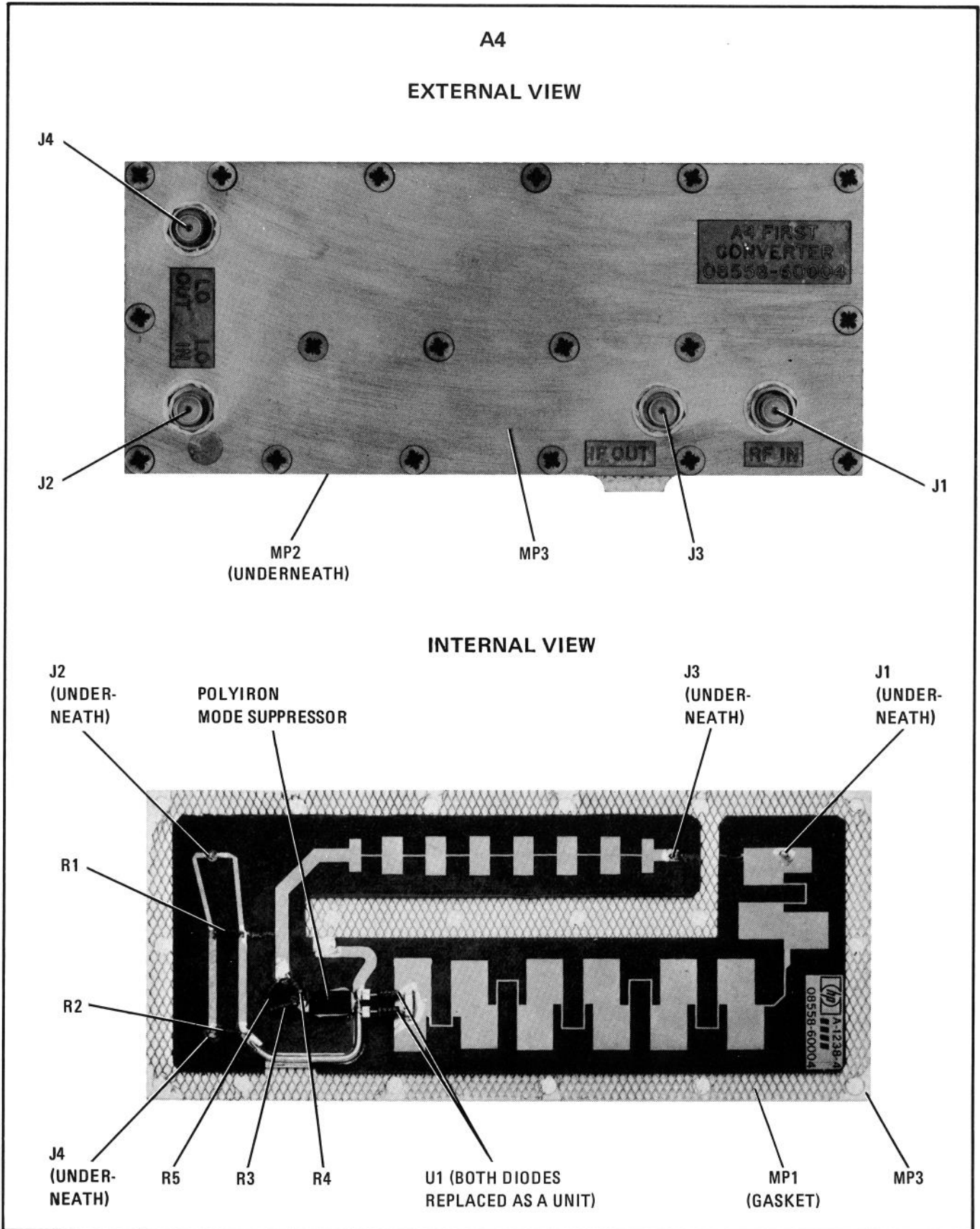

FIGURE 8-23. A4 FIRST CONVERTER ASSEMBLY, COMPONENT LOCATIONS

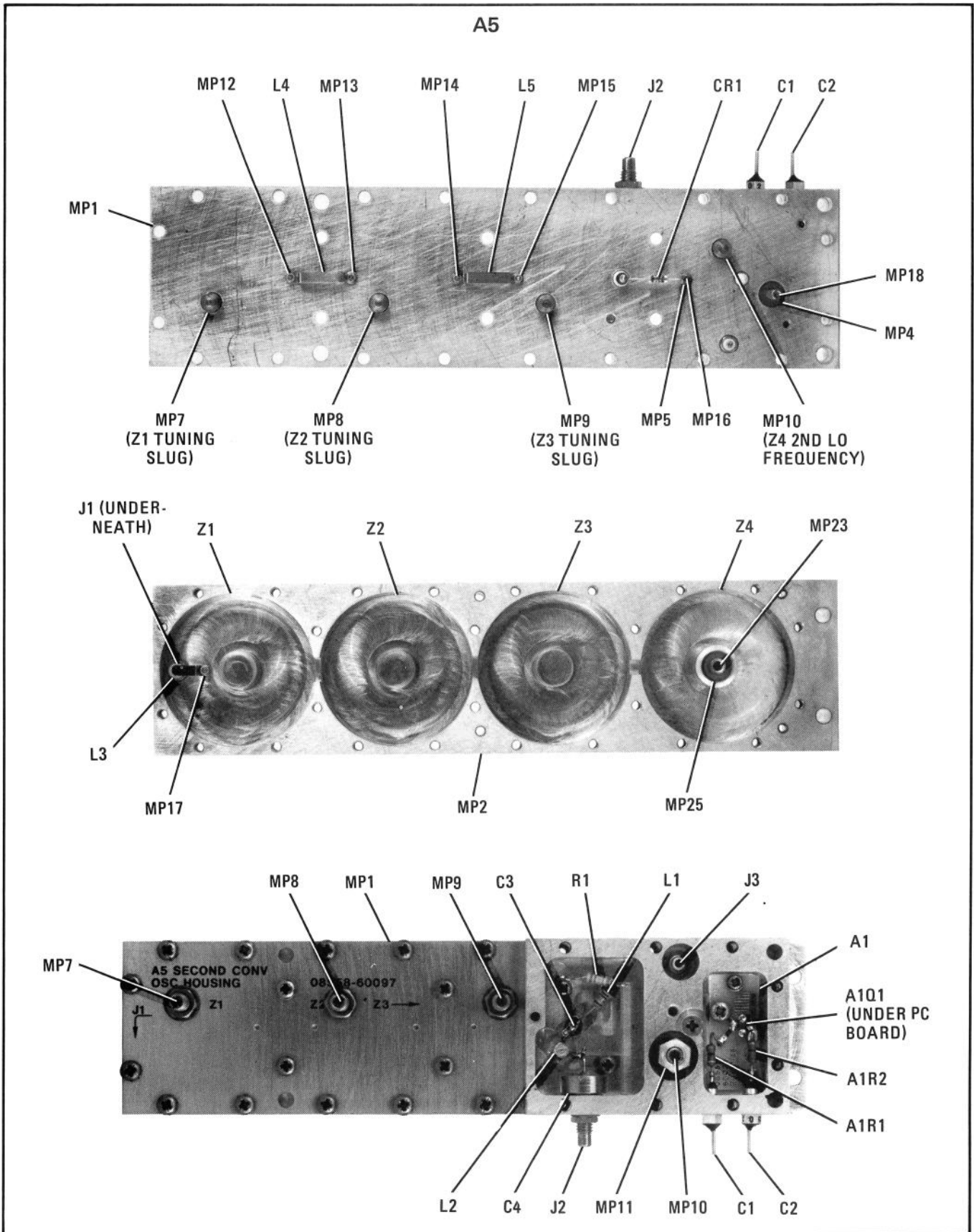

FIGURE 8-24. A5 SECOND CONVERTER ASSEMBLY, COMPONENT LOCATIONS

A7 FREQUENCY CONTROL, CIRCUIT DESCRIPTION

General Description

Frequency Control Assembly A7 contains the circuitry to drive and control YIG Oscillator Assembly A6. The frequency is controlled by the sum of the sweep and tune voltages. The tune voltage is generated by the center frequency coarse and fine TUNING controls. The tune voltage is measured by the digital panel meter (DPM) voltmeter to provide the center-frequency digital readout. The sweep voltage, controlled by the FREQ SPAN/DIV switch, is generated in Sweep Generator Assembly A8. The YIG Oscillator has two driving coils: the main tuning coil and the FM coil. The tune voltage is applied to the main tuning coil driver. The sweep voltage is either summed with the tune voltage and applied to the main tuning coil driver or, in narrow frequency spans, it is applied to the FM coil driver. Gating circuits determine whether the sweep voltage is applied to the main or FM coil. The Frequency Control Assembly also contains separate low-noise voltage regulators to bias the YIG Oscillator and the 1748.6 MHz second local oscillator.

YIG Main Coil Fixed Driver (J)

The YIG Main Coil Fixed Driver consists of differential amplifier A7Q7, a Darlington pair current source, A7Q5 and Q6, and a +6V reference voltage from A7VR2 and R4. The fixed driver is used to tune the YIG oscillator to the minimum frequency of 2050 MHz.

The +6V reference voltage is one input to A7Q7 and the other input, measured at TP3, is negative feedback that senses the voltage across A7R3 and R71. The operation of the fixed coil driver maintains a constant +6.0V across A7R3 and R71. All current through R3/R71 comes from the YIG main coil through Darlington current source A7Q5 and Q6. A7R3 is the 2.05 GHz lower frequency adjustment and sets the emitter current of A7Q5 and Q6. The current source provides the fixed current to determine the zero CENTER FREQUENCY point set by A7R3.

YIG Main Coil Swept Driver (H)

The YIG Main Coil Swept Driver consists of a swept driver, A7U4, and a Darlington pair current source, A7Q1 and Q3. The swept driver tunes the YIG oscillator over the frequency range of 2050 MHz to 3550 MHz. The inputs to A7U4 are the Coarse and Fine TUNING voltage from the Tune Summing Amplifier, and the attenuated sweep ramp from the Sweep Buffer. The output from A7U3 is the attenuated sweep only when 2 MHz/DIV or wider frequency spans have been selected. In narrower frequency spans, only the sum of the TUNING voltages is applied to the main coil swept driver. The attenuated sweep and TUNING voltages are summed across A7R49 and R52 and then applied to the noninverting input of A7U4. Diode A7CR3 prevents the input of the swept driver from going negative and driving it into cutoff. A7U4 drives the current source which converts the voltage at the emitter of Q1 into current to drive the YIG main tuning coil.

The current from A7Q1/Q3 is summed with the current from the fixed driver current source, A7Q5/Q6, to increase the main coil current synchronously with the TUNING and sweep voltages. The YIG upper frequency, 3.55 GHz, is set by A7R1 (coarse adjust) and A7R2 (fine adjust). The emitter of A7Q1 is connected to the inverting input of A7U4 to provide a voltage proportional to the collector current of Q1/Q3 to be used as negative feedback.

Frequency Analog Output for Blanking. The emitter of A7Q1 also drives the base of A7Q2. A7Q2 is an emitter follower that provides the frequency analog output voltage to Third Converter Assembly A3 and to the Sweep Ramp High/Low Limit Comparator (A15U1) of Vertical Driver and Blanking Assembly A15. (See A15 schematic.)

Coarse and Fine Tuning (E)

The Coarse and Fine tuning voltages from control potentiometers A2R1 and A2R2 (shown on A2 schematic) are applied to the noninverting and inverting inputs respectively of A7U2. A7U2 sums these voltages and applies the voltage sum to the junction of A7R52 and R53. It is in turn summed with the attenuated sweep

signal from the output of the sweep buffer A7U3 if 2 MHz/DIV or wider frequency spans have been selected. In narrower frequency spans the input of buffer A7U3 is grounded, so only the summed tuning voltages are applied to A7U4.

YIG FM Coil Driver (I)

The FM Coil Driver consists of A7U1, Q17, Q18, and FM adjust R6. Selecting 1 MHz/DIV and narrower frequency spans enables the YIG FM Coil Gate, allowing the attenuated sweep to be applied to the YIG FM Coil Driver. (A7Q15 is on and Q16 is off.) A7U1 converts the sweep ramp voltage into current to drive the YIG FM coil. Transistors A7Q17/Q18 are biased at cutoff and provide additional current drive. The FM adjust, A7R6, sets the maximum FM coil current.

YIG Main and FM Coil Gates (D) (F)

The YIG Coil Gates determine which YIG coil is used to control the YIG oscillator frequency. The YIG Coil Gates are selected by the Scan Select which is controlled by FREQ SPAN/DIV control A2S6.

YIG Main Coil Gate. When 2 MHz/DIV and wider frequency spans are selected, the base of transistor A7U5C is returned to -12.6V through A7R11 and A8R131. A7U5C is turned off and the collector rises to about -5V while the emitter drops near to -12.6V . The collector of A7U5C turns on U5E and U5D, and these two transistors then turn off FETs Q15 and Q24, respectively. The emitter of A7U5C turns off U5A and U5B, which then turn on FETs Q16 and Q20. With A7Q20 conducting and A7Q24 open, the attenuated sweep is applied to sweep buffer A7U3 and YIG main coil swept driver A7U4 to control the YIG oscillator frequency. FET A7Q15 is turned off, preventing the attenuated sweep input from reaching the YIG FM Coil Driver, and A7Q16 is turned on, grounding the input to the YIG FM coil driver.

YIG FM Coil Gate. The selection of 1 MHz/DIV and narrower frequency spans with FREQ SPAN/DIV control A2S6 applies $+15\text{V}$ to the input of A7U5C. The $+15\text{V}$ turns U5C on; FETs Q20 and Q16 are turned off, and FETs Q24 and Q15 are turned on. This enables the YIG FM coil gate, allowing the sweep signal to be applied to the YIG FM Coil Driver. A7Q20 prevents the Attenuated Sweep input from reaching the sweep buffer A7U3, and A7Q24 grounds the input of A7U3. However, the tuning voltage from the tune summing amplifier is still applied to the YIG main coil swept driver.

Main Coil Filter (L)

When the narrower frequency spans are selected, the $+15\text{V}$ from FREQ SPAN/DIV switch A2S6 is also applied to A7Q4 in the main coil filter. The main coil filter consists of FET switch A7Q4, R75, and C13/C14. The filter provides noise filtering in the 1 MHz and narrower frequency spans. With the FET switch closed, the filter is connected in parallel with the YIG main tuning coil.

Meter Ranging (K)

The DPM is a digital voltmeter which measures the TUNING voltage at the output of the tune summing amplifier. The output of the tune summing amplifier, approximately 0 to 10V, is divided down to 0 to 1.5V at pins 2 and 5 of A7U6 by A7R53 and R50. This provides a 1 mV/MHz voltage to the DPM. The FREQ ZERO adjust R3 (shown on A2 schematic), A7R43, and A7R54 enable this voltage to be offset $\pm 15\text{ mV}$ to zero the DPM. The FREQ ZERO adjustment compensates for the changes in the frequency of the YIG oscillator caused by temperature drift.

A7U6A functions as a comparator and A7U6B as a switchable X1/X10 gain stage. When the instrument is tuned to a frequency below 198.4 MHz, the voltage at A7U6 pin 2 is less than 198 mV. Since the voltage at A7U6 pin 3 is adjusted to be approximately 198 mV, the output at A7U6 pin 1 is positive. This turns on Q19, causing A7U6B to have a gain of approximately 10 and results in an output voltage at pin 7 of 10 mV/MHz.

When the instrument is tuned above 198.4 MHz, A7U6A pin 1 goes low, turning Q19 off, causing A7U6B to have a gain of 1. This results in an output voltage at pin 7 of 1 mV/MHz. The output of A7U6A pin 1 is also

used to turn A7Q25 off to turn off the decimal point. The positive feedback from the emitter of A7Q25 to A7U6A pin 3 provides hysteresis for rapid switching of the X1/X10 crossover point. A7CR6 and CR7 provide proper biasing for FET Q19. OFS adjustment A7R72 compensates for input offset of A7U6B.

+ 14.5V Regulator (M)

The + 14.5V Regulator consists of series regulator A7Q8, driver Q10, and reference amplifier Q9 and Q11. The + 6.2V developed across zener diode A7VR1 provides the base reference for A7Q9. This is compared to the voltage at the base of A7Q11 which senses the + 14.5V output across voltage divider A7R28, R29, and the + 14.5V adjust R5. Should the output voltage increase, A7Q11 will conduct more, decreasing the conduction of A7Q9 and driving the base of Q10 more positive. This decreases the drive current to A7Q8 and causes the output voltage to drop (return to + 14.5V). A7C4 provides stability compensation and some additional noise filtering at the output.

The + 14.5V supply is used for the positive supply on A7U2, U3, U4, and Q7. It is also used on Sweep Generator Assembly A8 as the voltage reference that sets the - 5V to + 5V ramp amplitude. The + 14.5V is also applied to Second Converter A5 as the positive supply for the 1748.6 MHz second local oscillator.

+ 6.00V Reference Voltage Regulator (A)

The + 14.5V at A7R32 and the + 6.2V dropped across A7VR2, develop the + 6.00V reference voltage. A7R4 REF V adjusts the voltage at TP6 to + 6.00V.

- 10V Regulator (N)

The regulated + 14.5V provides a reference voltage for voltage divider A7R34 and R35 for the - 10V regulator. The - 10V regulator consists of series regulator A7Q12 and reference amplifier A7Q13 and Q14. Should the - 10V tend to become more positive (less negative), A7Q13 decreases its conduction and turns A7Q14 on harder. A7Q14 then increases the conduction of A7Q12, dropping the output voltage back to - 10V.

The - 10V supply is used for the negative supply on A7U2, U3, U4, and Q7. It is also used as the negative supply for the A6 YIG Oscillator and the second local oscillator in A5.

Calibrate Single Shot (B)

The calibrate single shot circuit consists of A7Q23, Q22, and Q21. The circuit is activated when the front panel FREQ CAL button is pressed. With the FREQ CAL switch A2S8 (shown on A2 schematic) closed, the YIG Oscillator is tuned to its lowest frequency. Releasing the FREQ CAL button returns the YIG Oscillator to the previous operating frequency.

Pressing the FREQ CAL button shorts the + 6V line to ground, discharging A7C8 and turning A7Q23 off. The emitter of A7Q22 is grounded, turning it on, and its collector goes low, turning off FET switch A7Q4. The main coil filter is now disabled and the charge held on A7C13/C14 remains the same during the calibration sequence. The charge voltage represents the previous operating frequency. The ground on the + 6V line is applied to the base of A7Q7, disabling the YIG main coil fixed driver. When the + 6.0V line is grounded, the output of the coarse TUNING control is grounded; the YIG main coil swept driver is disabled by the output from A7U2. With both YIG main coil drivers disabled, the magnetic current is removed and the magnet hysteresis is cancelled.

When the FREQ CAL button is released, the + 6.0V reference line jumps to approximately + 1V. The charge on capacitor A7C8 turns on A7Q23 which then turns on Q21. A7C8, Q21, and Q23 form a Miller Integrator and the + 6.0V reference line slowly charges to + 6.0V. This takes about 0.3 seconds and prevents the introduction of transients into the main coil. However, as long as the + 6.0V reference line is charging; the conduction of A7Q23 keeps FET switch A7Q4 off, still disabling the main coil filter. The charge on A7C13/C14 has no path for discharge and remains the same. This allows the YIG Oscillator to return to the previous frequency faster, since A7C13 and C14 do not have to be recharged.

TABLE 8-7. A7 FREQUENCY CONTROL ASSEMBLY, REPLACEABLE PARTS (1 OF 3)

Reference Designation	HP Part Number	C D	Qty	Description	Mfr Code	Mfr Part Number
A7	08558-60126	2	1	FREQUENCY CONTROL ASSEMBLY	28480	08558-60126
A7C1	0180-1746	5	2	CAPACITOR-FXD 15UF+-10% 20VDC TA	56289	150D156X9020B2
A7C2	0180-1746	5	2	CAPACITOR-FXD 15UF+-10% 20VDC TA	56289	150D156X9020B2
A7C3	0160-3466	8	2	CAPACITOR-FXD 100PF +-10% 1KVDC CER	28480	0160-3466
A7C4	0180-0197	8	2	CAPACITOR-FXD 2.2UF+-10% 20VDC TA	56289	150D225X9020A2
A7C5	0160-3094	8	2	CAPACITOR-FXD .1UF +-10% 100VDC CER	28480	0160-3094
A7C6	0160-3457	7	1	CAPACITOR-FXD 2000PF +-10% 250VDC CER	28480	0160-3457
A7C7	0160-3094	8	1	CAPACITOR-FXD .1UF +-10% 100VDC CER	28480	0160-3094
A7C8	0180-0197	8	1	CAPACITOR-FXD 2.2UF+-10% 20VDC TA	56289	150D225X9020A2
A7C9	0180-1745	4	1	CAPACITOR-FXD 1.5UF+-10% 20VDC TA	56289	150D155X9020A2
A7C10	0160-3466	8	1	CAPACITOR-FXD 100PF +-10% 1KVDC CER	28480	0160-3466
A7C11	0160-2055	9	2	CAPACITOR-FXD .01UF +80-20% 100VDC CER	28480	0160-2055
A7C12	0160-2055	9	2	CAPACITOR-FXD .01UF +80-20% 100VDC CER	28480	0160-2055
A7C13	0180-1714	7	2	CAPACITOR-FXD 330UF+-10% 6VDC TA	56289	150D337X9006S2
A7C14	0180-1714	7	2	CAPACITOR-FXD 330UF+-10% 6VDC TA	56289	150D337X9006S2
A7CR1	1901-0040	1	4	DIODE-SWITCHING 30V 50MA 2NS DO-35	28480	1901-0040
A7CR2	1901-0535	9	1	DIODE-3M SIG SCHOTTKY	28480	1901-0535
A7CR3	1901-0040	1	1	DIODE-SWITCHING 30V 50MA 2NS DO-35	28480	1901-0040
A7CR4	1901-0040	1	1	DIODE-SWITCHING 30V 50MA 2NS DO-35	28480	1901-0040
A7CR5	1901-0050	3	3	DIODE-SWITCHING 80V 200MA 2NS DO-35	28480	1901-0050
A7CR6	1901-0050	3	1	DIODE-SWITCHING 80V 200MA 2NS DO-35	28480	1901-0050
A7CR7	1901-0050	3	1	DIODE-SWITCHING 80V 200MA 2NS DO-35	28480	1901-0050
A7CR8				NOT ASSIGNED		
A7CR9	1901-0040	1	1	DIODE-SWITCHING 30V 50MA 2NS DO-35	28480	1901-0040
A7L1	08558-80011	6	2	FILTER COIL BLUE	28480	08558-80011
A7L2	08558-80011	6	2	FILTER COIL BLUE	28480	08558-80011
A7Q1	1854-0039	7	3	TRANSISTOR NPN 2N3053S SI TO-39 PD=1W	3L585	2N3053S
A7Q2	1853-0451	5	1	TRANSISTOR PNP 2N3799 SI TO-18 PD=360MW	01295	2N3799
A7Q3	1854-0023	9	2	TRANSISTOR NPN SI TO-18 PD=360MW	28480	1854-0023
A7Q4	1855-0417	7	1	TRANSISTOR J-FET N-CHAN D-MODE TO-18 SI	28480	1855-0417
A7Q5	1854-0039	7	1	TRANSISTOR NPN 2N3053S SI TO-39 PD=1W	3L585	2N3053S
A7Q6	1854-0023	9	1	TRANSISTOR NPN SI TO-18 PD=360MW	28480	1854-0023
A7Q7	1854-0475	5	1	TRANSISTOR-DUAL NPN PD=750MW	28480	1854-0475
A7Q8	1853-0012	4	1	TRANSISTOR PNP 2N2904A SI TO-39 PD=600MW	01295	2N2904A
A7Q9	1854-0882	8	2	TRANSISTOR NPN PD=300MW FT=200MHZ	28480	1854-0882
A7Q10	1853-0007	7	4	TRANSISTOR PNP 2N3251 SI TO-18 PD=360MW	04713	2N3251
A7Q11	1854-0882	8	1	TRANSISTOR NPN PD=300MW FT=200MHZ	28480	1854-0882
A7Q12	1854-0039	7	1	TRANSISTOR NPN 2N3053S SI TO-39 PD=1W	3L585	2N3053S
A7Q13	1853-0007	7	1	TRANSISTOR PNP 2N3251 SI TO-18 PD=360MW	04713	2N3251
A7Q14	1853-0007	7	1	TRANSISTOR PNP 2N3251 SI TO-18 PD=360MW	04713	2N3251
A7Q15	1855-0062	8	4	TRANSISTOR J-FET N-CHAN D-MODE SI	28480	1855-0062
A7Q16	1855-0062	8	1	TRANSISTOR J-FET N-CHAN D-MODE SI	28480	1855-0062
A7Q17	1854-0404	0	5	TRANSISTOR NPN SI TO-18 PD=360MW	28480	1854-0404
A7Q18	1853-0007	7	1	TRANSISTOR PNP 2N3251 SI TO-18 PD=360MW	04713	2N3251
A7Q19	1855-0420	2	1	TRANSISTOR J-FET 2N4391 N-CHAN D-MODE	01295	2N4391
A7Q20	1855-0062	8	1	TRANSISTOR J-FET N-CHAN D-MODE SI	28480	1855-0062
A7Q21	1854-0404	0	1	TRANSISTOR NPN SI TO-18 PD=360MW	28480	1854-0404
A7Q22	1854-0404	0	1	TRANSISTOR NPN SI TO-18 PD=360MW	28480	1854-0404
A7Q23	1854-0404	0	1	TRANSISTOR NPN SI TO-18 PD=360MW	28480	1854-0404
A7Q24	1855-0062	8	1	TRANSISTOR J-FET N-CHAN D-MODE SI	28480	1855-0062
A7Q25	1854-0404	0	1	TRANSISTOR NPN SI TO-18 PD=360MW	28480	1854-0404
A7R1	2100-1754	9	2	RESISTOR-TRMR 50 5% WW SIDE-ADJ 1-TRN	28480	2100-1754
A7R2	2100-1760	7	1	RESISTOR-TRMR 5K 5% WW SIDE-ADJ 1-TRN	28480	2100-1760
A7R3	2100-1754	9	1	RESISTOR-TRMR 50 5% WW SIDE-ADJ 1-TRN	28480	2100-1754
A7R4	2100-1757	2	2	RESISTOR-TRMR 500 5% WW SIDE-ADJ 1-TRN	28480	2100-1757
A7R5	2100-1757	2	2	RESISTOR-TRMR 500 5% WW SIDE-ADJ 1-TRN	28480	2100-1757
A7R6	2100-1756	1	1	RESISTOR-TRMR 200 5% WW SIDE-ADJ 1-TRN	28480	2100-1756
A7R7	2100-3123	0	2	RESISTOR-TRMR 500 10% C SIDE-ADJ 17-TRN	02111	43P501
A7R8	2100-3123	0	1	RESISTOR-TRMR 500 10% C SIDE-ADJ 17-TRN	02111	43P501
A7R9	0698-3458	7	6	RESISTOR 348K 1% .125W F TC=0+-100	28480	0698-3458
A7R10	0757-0317	7	2	RESISTOR 1.33K 1% .125W F TC=0+-100	24546	C4-1/8-T0-1331-F
A7R11	0757-0465	6	5	RESISTOR 100K 1% .125W F TC=0+-100	24546	C4-1/8-T0-1003-F
A7R12	0683-1855	3	1	RESISTOR 1.8M 5% .25W FC TC=-900/+1100	01121	C81855
A7R13	0757-0280	3	2	RESISTOR 1K 1% .125W F TC=0+-100	24546	C4-1/8-T0-1001-F
A7R14	0757-0465	6	1	RESISTOR 100K 1% .125W F TC=0+-100	24546	C4-1/8-T0-1003-F
A7R15	0757-0465	6	1	RESISTOR 100K 1% .125W F TC=0+-100	24546	C4-1/8-T0-1003-F
A7R16	0757-0424	7	1	RESISTOR 1.1K 1% .125W F TC=0+-100	24546	C4-1/8-T0-1101-F
A7R17	0757-0274	5	1	RESISTOR 1.21K 1% .125W F TC=0+-100	24546	C4-1/8-T0-1211-F
A7R18	0698-3151	7	3	RESISTOR 2.87K 1% .125W F TC=0+-100	24546	C4-1/8-T0-2871-F
A7R19	0698-8913	9	2	RESISTOR 1.5M 1% .125W F TC=0+-100	28480	0698-8913
A7R20	0757-0438	3	2	RESISTOR 5.11K 1% .125W F TC=0+-100	24546	C4-1/8-T0-5111-F

*Indicates factory selected value

TABLE 8-7. A7 FREQUENCY CONTROL ASSEMBLY, REPLACEABLE PARTS (2 OF 3)

Reference Designation	HP Part Number	C D	Qty	Description	Mfr Code	Mfr Part Number
A7R21	0698-3458	7		RESISTOR 348K 1% .125W F TC=0+-100	28480	0698-3458
A7R22	0757-0465	6		RESISTOR 100K 1% .125W F TC=0+-100	24546	C4-1/8-T0-1003-F
A7R23	0698-8913	9		RESISTOR 1.5M 1% .125W F TC=0+-100	28480	0698-8913
A7R24	0698-3458	7		RESISTOR 348K 1% .125W F TC=0+-100	28480	0698-3458
A7R25	0757-0465	6		RESISTOR 100K 1% .125W F TC=0+-100	24546	C4-1/8-T0-1003-F
A7R26	0757-0438	3		RESISTOR 5.11K 1% .125W F TC=0+-100	24546	C4-1/8-T0-5111-F
A7R27	0698-0083	8	1	RESISTOR 1.96K 1% .125W F TC=0+-100	24546	C4-1/8-T0-1961-F
A7R28	0698-3153	9	3	RESISTOR 3.83K 1% .125W F TC=0+-100	24546	C4-1/8-T0-3831-F
A7R29	0698-3151	7		RESISTOR 2.87K 1% .125W F TC=0+-100	24546	C4-1/8-T0-2871-F
A7R30	0683-1555	0	3	RESISTOR 1.5M 5% .25W FC TC=-900/+1100	01121	CB1555
A7R31	0683-1555	0		RESISTOR 1.5M 5% .25W FC TC=-900/+1100	01121	CB1555
A7R32	0757-0280	3		RESISTOR 1K 1% .125W F TC=0+-100	24546	C4-1/8-T0-1001-F
A7R33	0698-3153	9		RESISTOR 3.83K 1% .125W F TC=0+-100	24546	C4-1/8-T0-3831-F
A7R34	0757-0290	5	3	RESISTOR 6.19K 1% .125W F TC=0+-100	19701	MF4C1/8-T0-6191-F
A7R35	0698-3154	0	1	RESISTOR 4.22K 1% .125W F TC=0+-100	24546	C4-1/8-T0-4221-F
A7R36	0698-3458	7		RESISTOR 348K 1% .125W F TC=0+-100	28480	0698-3458
A7R37	0698-3156	2	2	RESISTOR 14.7K 1% .125W F TC=0+-100	24546	C4-1/8-T0-1472-F
A7R38	0698-3453	2	1	RESISTOR 196K 1% .125W F TC=0+-100	24546	C4-1/8-T0-1963-F
A7R39	0757-0401	0	5	RESISTOR 100 1% .125W F TC=0+-100	24546	C4-1/8-T0-101-F
A7R40	0698-3458	7		RESISTOR 348K 1% .125W F TC=0+-100	28400	0698-3458
A7R41	0757-0470	3	2	RESISTOR 162K 1% .125W F TC=0+-100	24546	C4-1/8-T0-1623-F
A7R42	0698-3160	8	1	RESISTOR 31.6K 1% .125W F TC=0+-100	24546	C4-1/8-T0-3162-F
A7R43	0757-0470	3		RESISTOR 162K 1% .125W F TC=0+-100	24546	C4-1/8-T0-1623-F
A7R44	0757-0401	0		RESISTOR 100 1% .125W F TC=0+-100	24546	C4-1/8-T0-101-F
A7R45	0757-0401	0		RESISTOR 100 1% .125W F TC=0+-100	24546	C4-1/8-T0-101-F
A7R46	0757-0290	5		RESISTOR 6.19K 1% .125W F TC=0+-100	19701	MF4C1/8-T0-6191-F
A7R47	0757-0199	3	4	RESISTOR 21.5K 1% .125W F TC=0+-100	24546	C4-1/8-T0-2152-F
A7R48	0698-3151	7		RESISTOR 2.87K 1% .125W F TC=0+-100	24546	C4-1/8-T0-2871-F
A7R49	0698-6271	8	1	RESISTOR 3K .1% .125W F TC=0+-50	28480	0698-6271
A7R50	0698-6315	1	1	RESISTOR 503.1 .25% .125W F TC=0+-100	03888	PME55-1/8-T0-503R1-C
A7R51	0683-1555	0		RESISTOR 1.5M 5% .25W FC TC=-900/+1100	01121	CB1555
A7R52	0698-7799	7	1	RESISTOR 2K .25% .125W F TC=0+-100	19701	MF4C1/8-T0-2001-C
A7R53	0698-8323	5	1	RESISTOR 2.76K .25% .125W F TC=0+-50	19701	MF4C1/8-T2-2761-C
A7R54	0698-3458	7		RESISTOR 348K 1% .125W F TC=0+-100	28480	0698-3458
A7R55	0698-3438	3	1	RESISTOR 147 1% .125W F TC=0+-100	24546	C4-1/8-T0-147R-F
A7R56	0698-3162	0	1	RESISTOR 46.4K 1% .125W F TC=0+-100	24546	C4-1/8-T0-4642-F
A7R57	0757-0317	7		RESISTOR 1.33K 1% .125W F TC=0+-100	24546	C4-1/8-T0-1331-F
A7R58	0757-0290	5		RESISTOR 6.19K 1% .125W F TC=0+-100	19701	MF4C1/8-T0-6191-F
A7R59	0757-0279	0	1	RESISTOR 3.16K 1% .125W F TC=0+-100	24546	C4-1/8-T0-3161-F
A7R60	0698-3153	9		RESISTOR 3.83K 1% .125W F TC=0+-100	24546	C4-1/8-T0-3831-F
A7R61	0757-0401	0		RESISTOR 100 1% .125W F TC=0+-100	24546	C4-1/8-T0-101-F
A7R62	0757-0416	7	1	RESISTOR 511 1% .125W F TC=0+-100	24546	C4-1/8-T0-511R-F
A7R63	0757-0199	3		RESISTOR 21.5K 1% .125W F TC=0+-100	24546	C4-1/8-T0-2152-F
A7R64	0698-3450	9	1	RESISTOR 42.2K 1% .125W F TC=0+-100	24546	C4-1/8-T0-4222-F
A7R65	0757-0441	8	1	RESISTOR 8.25K 1% .125W F TC=0+-100	24546	C4-1/8-T0-8251-F
A7R66	0811-3247	4	1	RESISTOR 150 1% 7.5W PW TC=0+-20	28480	0811-3247
A7R67	0683-1065	7	2	RESISTOR 10M 5% .25W CC TC=-900/+1100	01121	CB1065
A7R68	0698-3156	2		RESISTOR 14.7K 1% .125W F TC=0+-100	24546	C4-1/8-T0-1472-F
A7R69	0757-0199	3		RESISTOR 21.5K 1% .125W F TC=0+-100	24546	C4-1/8-T0-2152-F
A7R70	0757-0401	0		RESISTOR 100 1% .125W F TC=0+-100	24546	C4-1/8-T0-101-F
A7R71	0811-3246	3	1	RESISTOR 110 1% 7.5W PW TC=0+-20	28480	0811-3246
A7R72	2100-3094	4	1	RESISTOR-TRMR 100K 10% C SIDE-ADJ 17-TRN	02111	43P104
A7R73	0757-0462	3	1	RESISTOR 75K 1% .125W F TC=0+-100	24546	C4-1/8-T0-7502-F
A7R74	0757-0459	8	1	RESISTOR 56.2K 1% .125W F TC=0+-100	24546	C4-1/8-T0-5622-F
A7R75	0698-3428	1	1	RESISTOR 14.7 1% .125W F TC=0+-100	03888	PME55-1/8-T0-14R7-F
A7R76	0757-0199	3		RESISTOR 21.5K 1% .125W F TC=0+-100	24546	C4-1/8-T0-2152-F
A7R77	0698-3132	4	1	RESISTOR 261 1% .125W F TC=0+-100	24546	C4-1/8-T0-2610-F
A7R78	0683-1065	7		RESISTOR 10M 5% .25W CC TC=-900/+1100	01121	CB1065
A7R79	0757-0422	5	1	RESISTOR 909 1% .125W F TC=0+-100	24546	C4-1/8-T0-909R-F
A7TP1	1251-0600	0	18	CONNECTOR-SGL CONT PIN 1.14-MM-BSC-SZ SQ	28480	1251-0600
A7TP2	1251-0600	0		CONNECTOR-SGL CONT PIN 1.14-MM-BSC-SZ SQ	28480	1251-0600
A7TP3	1251-0600	0		CONNECTOR-SGL CONT PIN 1.14-MM-BSC-SZ SQ	28480	1251-0600
A7TP4	1251-0600	0		CONNECTOR-SGL CONT PIN 1.14-MM-BSC-SZ SQ	28480	1251-0600
A7TP5	1251-0600	0		CONNECTOR-SGL CONT PIN 1.14-MM-BSC-SZ SQ	28480	1251-0600
A7TP6	1251-0600	0		CONNECTOR-SGL CONT PIN 1.14-MM-BSC-SZ SQ	28480	1251-0600
A7TP7	1251-0600	0		CONNECTOR-SGL CONT PIN 1.14-MM-BSC-SZ SQ	28480	1251-0600
A7TP8	1251-0600	0		CONNECTOR-SGL CONT PIN 1.14-MM-BSC-SZ SQ	28480	1251-0600
A7TP9	1251-0600	0		CONNECTOR-SGL CONT PIN 1.14-MM-BSC-SZ SQ	28480	1251-0600
A7TP10	1251-0600	0		CONNECTOR-SGL CONT PIN 1.14-MM-BSC-SZ SQ	28480	1251-0600
A7TP11				NOT ASSIGNED		
A7TP12				NOT ASSIGNED		
A7TP13	1251-0600	0		CONNECTOR-SGL CONT PIN 1.14-MM-BSC-SZ SQ	28480	1251-0600
A7TP14	1251-0600	0		CONNECTOR-SGL CONT PIN 1.14-MM-BSC-SZ SQ	28480	1251-0600
A7TP15	1251-0600	0		CONNECTOR-SGL CONT PIN 1.14-MM-BSC-SZ SQ	28480	1251-0600

*Indicates factory selected value

TABLE 8-7. A7 FREQUENCY CONTROL ASSEMBLY, REPLACEABLE PARTS (3 OF 3)

Reference Designation	HP Part Number	C D	Qty	Description	Mfr Code	Mfr Part Number
A7TP16	1251-0600	0		CONNECTOR-SGL CONT PIN 1.14-MM-BSC-SZ SQ	28480	1251-0600
A7TP17	1251-0600	0		CONNECTOR-SGL CONT PIN 1.14-MM-BSC-SZ SQ	28480	1251-0600
A7TP18	1251-0600	0		CONNECTOR-SGL CONT PIN 1.14-MM-BSC-SZ SQ	28480	1251-0600
A7TP19	1251-0600	0		CONNECTOR-SGL CONT PIN 1.14-MM-BSC-SZ SQ	28480	1251-0600
A7TP20	1251-0600	0		CONNECTOR-SGL CONT PIN 1.14-MM-BSC-SZ SQ	28480	1251-0600
A7U1	1826-1058	3	1	IC OP AMP GP 8-TO-99 PKG	28480	1826-1058
A7U2	5180-2314	0	3	IC 05C M1 OP AMP	28480	5180-2314
				NOTE:USE AS ALTERNATE FOR 5180-2315		
A7U2	5180-2315	1	3	IC 05C M1 OP AMP	28480	5180-2315
A7U3	5180-2314	0		IC 05C M1 OP AMP	28480	5180-2314
				NOTE:USE AS ALTERNATE FOR 5180-2315		
A7U3	5180-2315	1		IC 05C M1 OP AMP	28480	5180-2315
A7U4	5180-2314	0		IC 05C M1 OP AMP	28480	5180-2314
				NOTE:USE AS ALTERNATE FOR 5180-2315		
A7U4	5180-2315	1		IC 05C M1 OP AMP	28480	5180-2315
A7U5	1858-0032	8	1	TRANSISTOR ARRAY 14-PIN PLSTC DIP	3L585	CA3146E
A7U6	1826-0092	3	1	IC OP AMP GP DUAL TO-99 PKG	28480	1826-0092
A7VR1	1902-0033	4	1	DIODE-ZNR 1N823 6.2V 5% DO-7 PD=.4W	24046	1N823
A7VR2	1902-0680	7	1	DIODE-ZNR 1N827 6.2V 5% DO-7 PD=.4W	24046	1N827
A7VR3	1902-0202	9	1	DIODE-ZNR 15V 5% PD=1W IR=50A	28480	1902-0202
				MISCELLANEOUS		
	08558-00007	2	1	HEAT SINK YIG DR	28480	08558-00007
	1200-0173	5	6	INSULATOR-XSTR DAP-GL	28480	1200-0173
	1205-0002	9	3	HEAT SINK TO-5/TO-39-CS	28480	1205-0002
	0520-0129	8	4	SCREW-MACH 2-56 .312-IN-LG PAN-IND-POZI	00000	ORDER BY DESCRIPTION
	0610-0001	6	4	NUT-HEX-DBL-CHAM 2-56-THD .062-IN-THK	00000	ORDER BY DESCRIPTION
	2190-0014	1	4	WASHER-LK INTL T NO. 2 .089-IN-ID	28480	2190-0014

*Indicates factory selected value

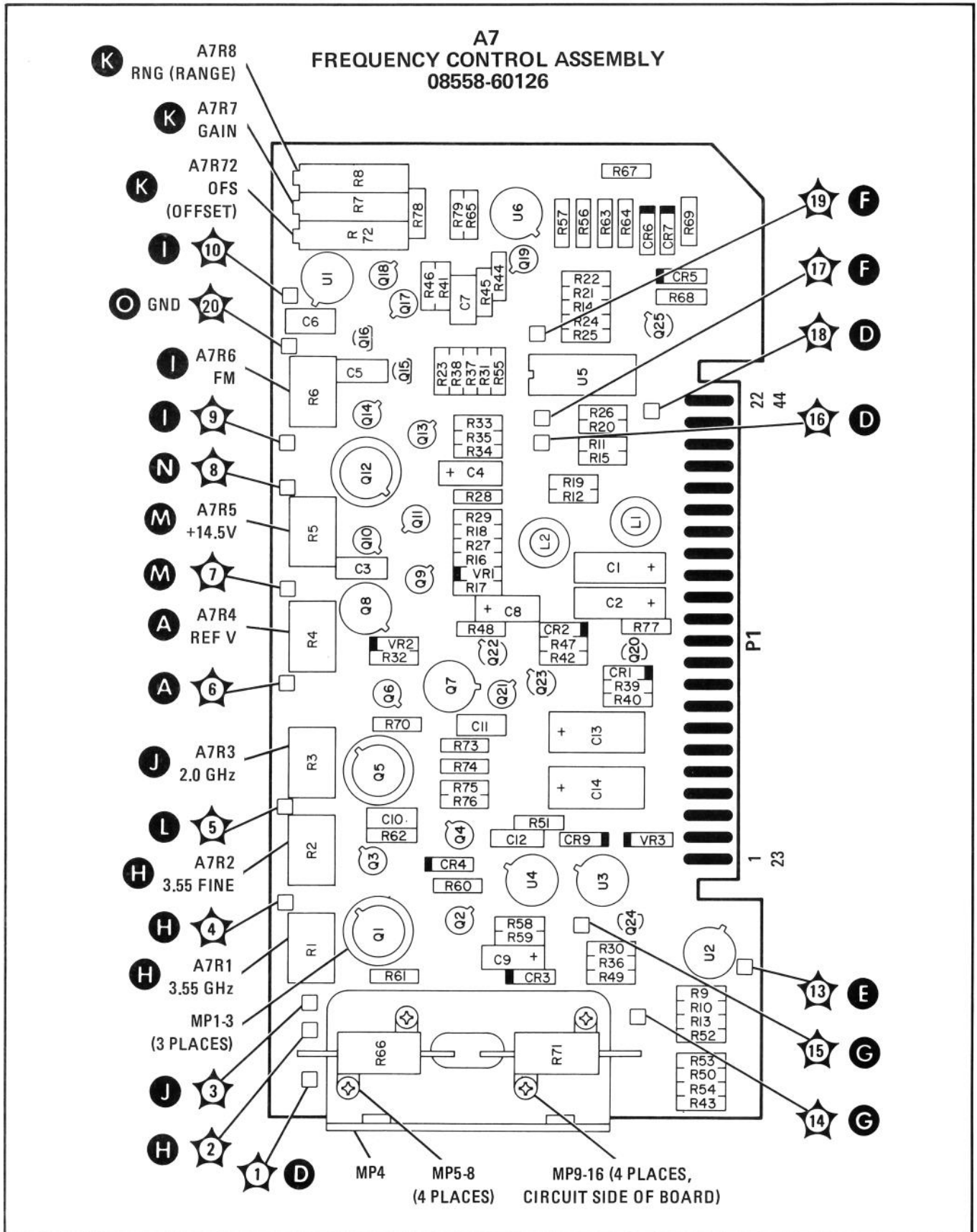

FIGURE 8-26. A7 FREQUENCY CONTROL ASSEMBLY, COMPONENT LOCATIONS

A8 SWEEP GENERATOR/BANDWIDTH CONTROL ASSEMBLY, CIRCUIT DESCRIPTION

The Sweep Generator/Bandwidth Control Assembly A8 consists of the sweep generator circuit, the sweep trigger circuits, the resolution bandwidth control circuits, the video filtering circuits, the sweep attenuator circuit, and the sweep offset circuit.

A linear sweep from -5V to $+5\text{V}$ is provided by the sweep generator circuit. Normally, the sweep operates in a free run mode with sweep times automatically generated as a function of the **FREQ SPAN/DIV**, **RESOLUTION BW**, and **VIDEO FILTER** settings.

Fixed calibrated sweep times are available, ranging from 0.1 ms per division to 10s per division. This equals a full sweep time (10 divisions) of 1 ms to 100s. Fixed sweep times are set with the front panel **SWEEP TIME/DIV** control and are used mainly in zero span to determine the modulation frequency of an input signal. Modulation frequency determination is possible because during zero span operation the analyzer displays the signal in the time domain rather than the frequency domain. The sweep can also be controlled manually from the front panel with the **MANUAL** sweep control.

Besides internal triggering, **SINGLE**, **VIDEO**, and **LINE** triggering modes are also available. **SINGLE** starts or stops a single sweep from the front panel. **VIDEO** triggering allows the sweep to be synchronized with the video signal. **LINE** mode synchronizes the sweep with the line frequency. Single sweeps can be initiated via HP-IB if an HP 853A Spectrum Analyzer Display is being used.

The resolution bandwidth control circuit has three functions: First, it provides bandwidth-filter-control current to the PIN diodes on the Bandwidth Filter assemblies (A11 and A13). Second, it provides current to the sweep generator current source (via the **AST** line) to control the automatic sweep time circuit as a function of resolution bandwidth. Third, it switches in capacitance to the video filter to provide video filtering as a constant percentage of resolution bandwidth.

The sweep attenuator circuit attenuates the sweep ramp to the Frequency Control Assembly A7 in proportion to the **FREQ SPAN/DIV** selected. It also provides current to the sweep generator current source (via the **AST** line) to control the automatic sweep time circuit as a function of the **FREQ SPAN/DIV** control setting.

The sweep offset circuit offsets the ramp voltage by $+5\text{V}$ so the ramp voltage, when **START** frequency is selected, is from 0 to $+10\text{V}$ instead of -5 to $+5\text{V}$.

Sweep Generator (F) (I) (H) (L)

The sweep generator circuit comprises the current source F, the buffer amplifier I, the comparator H, and the retrace-out buffer amplifier L. A simplified schematic is shown in Figure 8-28.

When **AUTO** sweep is selected, the voltage ramp is generated as follows: The ramp begins when the dead-time capacitor (comprising C10 and C11 in block L) charges to about $+1.2\text{V}$ through R44. This turns Q33 on and drives pin 2 of the comparator (block H) below $+2.78\text{V}$. The output of the comparator then rises to about $+14\text{V}$, reverse biasing reset-diode CR2 (block I).

With CR2 off, the current source begins charging the timing capacitor (C3 and C4, block I). As the timing capacitor charges, the output of the buffer amplifier increases linearly. Transistor Q33 is on and its collector voltage is about $+0.5\text{V}$. The voltage at U1 pin 2 is mainly established by sweep voltage divider R29, R39, and R47*. (Components VR1, CR4, and R40 feed back some of the comparator's output to pin 2 and act upon the divider. These components have been omitted to simplify the model; see block L on the main schematic.)

When the ramp voltage reaches $+5\text{V}$, U1 pin 2 is approximately $+2.78\text{V}$. Consequently, the comparator's output swings to about -4V . This negative change reverse biases CR6 and turns Q33 off. Resistors R42*, R39, and R29 form a divider that, when combined with the feedback loop and the buffer amplifier, sets the ramp voltage at -5V during the dead time. (Factory-selected resistor R42* adjusts the dead time voltage.)

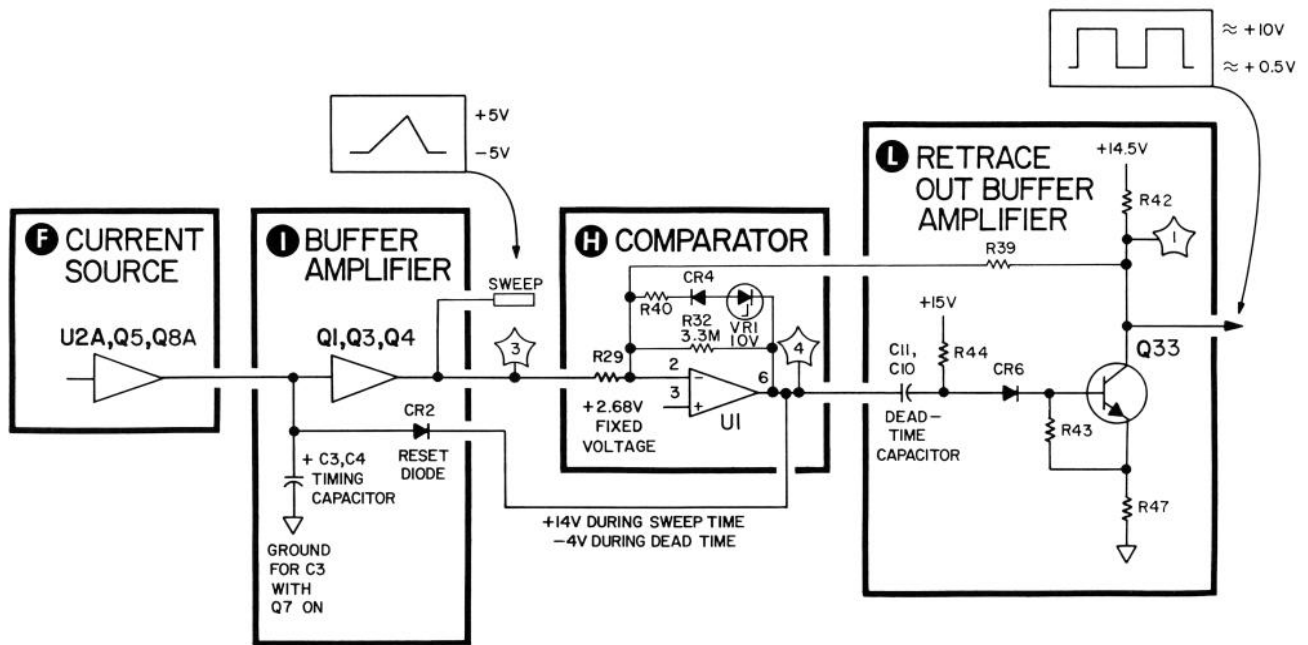

FIGURE 8-28. SIMPLIFIED SCHEMATIC OF SWEEP GENERATOR IN AUTO MODE

The timing capacitor is discharged by the comparator and quickly reaches -5V . The ramp remains at -5V until the dead time capacitor charges to $+1.2\text{V}$ and the sweep cycle is repeated.

Other components in the sweep generator have the following functions: Capacitor C6 speeds up the switching of U1. Capacitor C8 and resistor R33 desensitize U1 from power spikes. Frequency compensation for U1 is provided by C9, feedback compensation by C7. Zener diode VR1, switching diode CR4, and resistor R40 bring U1 out of saturation at the end of the ramp to improve switching time.

Fast/slow Sweep Time Operation

Timing capacitors C3 and C4 provide fast and slow sweep operation. When a sweep time less than or equal to 1 ms per division is selected with the SWEEP TIME/DIV front panel switch, sweep control line ST6 is grounded. This turns sweep dead time switch Q6 (block K) and fast sweep switch Q7 (block J) off. With Q7 off, C3 and C4 are in series; C4 effectively becomes the timing capacitor. With Q6 off, $+15\text{V}$ at R46 reverse biases CR9 and CR8, switching C10 out of the dead time circuit. Capacitor C11 now sets the short dead time to about 0.4 ms.

In sweep times greater than or equal to 1 ms per division or in automatic sweep, control line ST6 is open, turning both Q6 and Q7 on. Transistor Q7 grounds C3 and it becomes the timing capacitor. Transistor Q6 forward biases CR8 and CR9, paralleling C10 and C11. The dead time is effectively established by C10 at about 8.0 ms.

Pulse Shaper (M)

The pulse shaper circuit (block M) consists of a FET switch, a Schmitt trigger, a differentiator, and an emitter follower. Field-effect transistor Q56, and its associated components, disconnects the base of Q35 during the sweep cycle to prevent the Schmitt trigger from firing during a sweep. Transistors Q34 and Q35 make up the Schmitt trigger. Transistor Q35 is normally off; Q34 is conducting. On the positive portion of the input signal (either video or line), Q35 is driven into conduction, turning Q34 off. The switching speed of Q34 and Q35 is increased by feedback (between the collector of Q35 and the base of Q34) through C13 and R58.

When Q35 switches on, the negative change at the collector is differentiated by C14 and R60 and coupled through Q36 to the emitter of Q33. The negative pulse causes Q33 to turn on. Zener diode VR1, switching diode CR5, and resistor R41 keep Q33 on while the ramp is generated. When the ramp is completed, the circuit returns to its dead time state until another negative trigger pulse begins a new sweep cycle.

Free Run

During FREE RUN (internally triggered) mode, the trigger switch grounds the sync line, which removes the pulse shaper (block M) from the circuit. At the same time, the switch applies +15V through the trigger (TRIG) line to voltage divider R52 and R53 (block L). This divider sets the voltage at the cathode of CR10 at approximately +1.4V. Since the voltage drops across CR10 and CR6 are equal but opposite, they cancel. For this reason, the base of Q33 is also about +1.4V. Transistor Q33 turns on and drives the comparator to about +14V, initiating free run operation as described in the sweep generator section.

Video Triggering

When the TRIGGER switch is in the VIDEO position, the trigger line is open and the video signal (from the Vertical Driver/Blanking Assembly A15) is applied to the pulse shaper (block M) through the sync line. With the trigger line open, Q33 is held off until a negative pulse turns Q33 on and begins the sweep cycle outlined in the sweep generator description. At the end of the sweep, Q33 is again held off until the next pulse.

Line Triggering

The sweep may be synchronized with the ac line voltage in the same manner as described for video triggering. With the TRIGGER switch in the line position, the ac line from the mainframe power transformer is connected to the Pulse Shaper. Resistor A16R2 and capacitor A16C8 on the motherboard attenuate the ac line signal to approximately 1V peak-to-peak (at the base of Q35) and filter line spikes.

Single Sweep Triggering and Abort

When the trigger switch is in the single sweep position, the sync line is grounded and the single line open. Transistor Q33 is held off by the voltage developed across CR10 and R53. The voltage at the collector of Q33 is at +10V, putting the emitter of Q38 at +9.4V. This charges C15 to +2.4V through voltage divider R48 and R49.

A sweep is initiated when the trigger switch is set to the spring-loaded SINGLE position and +15V is applied to the single trigger switch (block N). When Q37 turns on, a negative pulse is produced at the emitter of Q33 due to the voltage stored by C15. This pulse turns Q33 on and starts the sweep cycle.

The sweep may be aborted (reset to -5V) by pressing the single sweep switch while the sweep is in progress. During the sweep, the collector of Q33 is at +0.5V. This puts the emitter of Q38 at 0V and charges C15 to -4V through voltage divider R48 and R49. Now when +15V is applied to the single trigger switch (block N), Q37 turns on and a positive pulse appears at the emitter of Q33. Consequently, Q33 turns off and the sweep is aborted.

Manual Sweep

Manual Sweep control is obtained when the SWEEP TIME/DIV switch is set to MAN. In the manual position ST7 is open. Transistor Q40 turns Q33 on by supplying current to its base and Q39 acts as a switch that connects R34 to the comparator. Turning the manual sweep control (A2R4) adjusts the voltage at the control side of R34.

Operational amplifier U1, operating in a linear mode, fixes the voltage at pin 2 by feedback through CR2, the buffer amplifier, and R29. This fixed voltage is applied through Q39 to one side of R34. As the manual sweep potentiometer is adjusted, the voltage across R34 changes, varying the current supplied to pin 2 of the comparator. This current is forced through R29 and develops the voltage offset that varies the ramp voltage.

Current Source (F)

The current source provides a constant charging current to the timing capacitors (block I) at a rate selected by either the SWEEP TIME/DIV switch or the automatic sweep time (AST) line.

Temperature compensation of the current source is accomplished by the nominal +10V supplied by the temperature-dependent power supply (block P). The 1 MS (one millisecond) adjustment fixes a voltage at pin 3 of U2A, while the 5 MS adjustment varies the feedback around U2A.

During calibrated sweep time settings, the Sweep Cal Switch (Q11 in block G) is off. This allows the feedback ratio of U2A, the voltage source, to be varied by grounding different input resistor combinations (R21 through R24) with the SWEEP TIME/DIV switch. In the automatic sweep mode, Sweep Cal Switch Q11 is turned on by current through Q9 and R25. The feedback ratio now varies with the resistors attached to the AST line and switched in by various settings of the FREQ SPAN/DIV and RESOLUTION BW switches. When the video filter is on, it also affects the feedback and, therefore, the sweep time, by varying the voltage at the emitter of Q8A.

The voltage applied to the emitter of Q8A from voltage source U2A is proportional to the logarithm of the sweep time. Transistor Q8A converts this voltage to a current directly proportional to the sweep time, which charges the timing capacitors in the buffer amplifier. A current limiter composed of Q5 and R15 limits the automatic sweep time to about 1.5 ms per division.

XTAL Resolution Bandwidth Control (B)

When the front panel RESOLUTION BW switch selects a crystal filtered bandwidth (≤ 30 KHz), bandwidth control line BW5 is open and pulled to $-0.5V$ by Q12 and Q10 in the XTAL PIN driver (block D). As a result, four simultaneous changes occur in the analyzer: the crystal poles on the Bandwidth Filter assemblies are activated, the LC poles are disabled, the crystal bandwidth control current is established, and the automatic sweep time is scaled for the crystal bandwidths.

Control line BW5, from the front panel RESOLUTION BW switch, is routed to the Bandwidth Filter assemblies (A11 and A13) where it activates the crystal filter poles. It reverse biases A11/A13CR2 (block D) and A11/A13CR13 (block G). At the same time, A11/A13Q3 and A11/A13CR8 (block D) and A11/A13Q6 and A11/A13CR15 (block G) are turned on.

The LC poles on the Bandwidth Filter assemblies are disabled by a positive voltage on the BW7 control line. Voltage for BW7 is generated in the LC PIN Driver (block C) on the Sweep Generator/Bandwidth Control Assembly A8. Control line BW5 turns A11/A13Q22 off, allowing BW7 to be pulled to a level greater than +10V by A11/A13CR17 and A11/A13R105. This turns off the LC filter sections.

Crystal filter bandwidth is determined by the current on BW6. Transistor Q13 in the XTAL PIN Driver (block D) is turned off, allowing Q14 to establish the bandwidth control current. Depending on the setting of the RESOLUTION BW switch, one of the bandwidth control lines (BW1 through BW3) is at +15V while the remaining two are open and pulled to a negative voltage. The positive voltage turns on one of the transistor switches in the XTAL Resolution Bandwidth control (Q42, Q44, or Q46 in block B). The current on BW6 is now established by one of the factory selected resistors, R109, R110, or R111, and the setting of R72 (the crystal bandwidth adjustment, block D). When the 30 kHz bandwidth is selected, no current is drawn through Q14 and the bandwidth control PIN diodes (A11/A13CR4 and A11/A13CR12 on the Bandwidth Filter assemblies) are off.

The automatic sweep time (AST) is determined by combinations of resistors switched into the current source circuit by front panel settings. (See the current source circuit description.) These resistors are located in blocks A, F, O, and the VIDEO FILTER switch A2S2. The contribution of the RESOLUTION BW occurs in the LC Resolution Bandwidth Control (block A). Resistors R117, R119, R121, and R122 are switched into the AST circuit by Q31, Q26, Q27, and Q28, respectively, when the proper control line is activated. Control lines BW2

through BW4 and the noise measure position of the VIDEO FILTER switch apply +15V to their respective control lines. The same lines are used to control sweep times in both crystal and LC modes. Since the same resistors are used to establish the automatic sweep time for both crystal and LC modes, scaling is necessary. To scale the sweep time, Q24 in block A switches R75 in or out of the AST circuit. During crystal filter operation, BW5 turns Q24 off and removes R75 from the circuit, allowing a longer sweep time.

LC Resolution Bandwidth Control (A)

When an LC filtered bandwidth (≤ 100 kHz) is selected, control line BW5 is pulled to +15V by the front panel RESOLUTION BW switch. This results in four simultaneous changes in the analyzer: the LC poles on the Bandwidth Filter assemblies (A11 and A13) are activated, the crystal poles are disabled, the LC bandwidth control current is established, and the automatic sweep time is scaled for LC bandwidths.

With +15V routed to the Bandwidth Filter assemblies by BW5, A11/A13Q3, A11/A13Q6, A11/A13CR8, and A11/A13CR15 are turned off and A11/A13CR2 and A11/A13CR13 are on. This blocks any signal from passing through the crystal filter sections. Transistor A8Q13 (block D) turns on and control line BW6 is pulled to -4V, which further inhibits the crystal filters.

The defeat of the crystal filter poles and the application of bandwidth control current on the BW7 line activates the LC filter sections. The LC bandwidth is controlled by the current through BW7 to the Bandwidth Filter assemblies. Transistor Q22, in the LC PIN Driver (block C), is turned on, allowing the current on BW7 to be controlled by Q21. The position of the RESOLUTION BW switch, via BW2 through BW4, turns one of the transistor switches (Q26, Q27, or Q31) in the LC Resolution Bandwidth Control (block A) on. The bandwidth control current on BW7 is now determined by a factory selected resistor, either R116, R118, or R120, and R85 (block C). If the 100 kHz bandwidth is selected, Q22 is turned on, but BW7 is pulled up to greater than +10V through R106. The bandwidth control PIN diodes (A11/A13CR3 and A11/A13CR11 on the Bandwidth Filter assemblies) are reverse biased by BW7.

Automatic sweep time scaling for LC occurs when BW5 turns Q24 (block A) on. This switches R75 into the AST circuit and decreases the sweep time. The effect on the automatic sweep time is determined by the parallel combination of R75 and the resistor (R117, R119, R121, or R122) selected by the active control line.

Video Filter

The video filter comprises front panel control A2R6, RESOLUTION BW switch A2A1S5, and eight capacitors on the Sweep Generator/Bandwidth Control Assembly A8 (blocks A and B). VIDEO FILTER control A2R6 varies the resistance of the RC filtering network that it forms with the video filter capacitor. The RESOLUTION BW setting determines which video filter capacitor will be switched in by the transistor switches (Q41, Q43, Q45, and Q47 in crystal bandwidths and Q54, Q32, Q30, and Q55 in LC bandwidths). Increased capacitance is switched in to provide increased filtering as the bandwidth narrows.

The output of the XTAL PIN Driver (BW6) is applied to the base of Q42, Q44, Q46, and Q47 via CR18 through CR21. This holds the transistors off and prevents the crystal mode video filter capacitors from being switched into the circuit during LC mode operation. It is not necessary to switch the LC mode video filter capacitors out of the circuit during crystal operation; their values are so much smaller that they are effectively out of the circuit.

Switch A2S2 applies maximum video filtering for noise measurements by turning on Q55, which switches in C28.

Sweep Attenuator (O)

The Sweep Attenuator circuit attenuates the full span sweep (-5V to +5V), before it is applied to the Frequency Control Assembly A7, as a function of the FREQ SPAN/DIV setting. The attenuation occurs in a 1-2-5-10 sequence. The circuit also varies the automatic sweep time (AST) as a function of the frequency span. The

circuit has two voltage dividers separated by U3, the unity gain sweep buffer. The input divider provides divide-by-two and divide-by-five; the output divider provides divide-by-ten and divide-by-one hundred. Note, the sweep output from the Buffer Amplifier (block I) is the input for the Sweep Attenuator (edge connector P1-40 and P1-39 are connected together).

To select any of the input dividers, +15V is applied to activate the associated control line. For example, if FS3 is activated, Q51 and Q50 turn on and ground R102 and R73. Resistor R102 becomes part of the AST circuit; R73 forms a divider with R70, that results in the ramp voltage being divided by two. The divided ramp is then applied to the sweep buffer.

The dividers at the output of the sweep buffer have reversed control logic. That is, they are normally connected to +15V by the FREQ SPAN/DIV switch and open (0V) when selected. Transistor Q19 is a gate to drive Q17. When FS4 and FS5 are connected to +15V, Q19 is off. As a result, Q17 is on and opens a path for the sweep buffer's output to P1-12. No attenuation takes place. If either FS4 or FS5 opens, Q17 shuts off. When FS4 opens, Q16 turns on and a divide-by-ten ($R81/R82 + R83$) is provided. When FS5 opens, Q15 turns on and provides a divide-by-one hundred ($R81 + R82/R83$).

Automatic sweep is varied as a function of frequency span by transistors Q53, Q51, Q49, Q29, Q25, and Q23. Transistor Q29 is switched on in narrow spans (<1 MHz/Div) when the YIG FM coil is swept. All of these transistors act as switches connecting resistors from the AST line to ground. This varies the sweep time. (See the Current Source circuit description.) As the FREQ SPAN/DIV is narrowed, the sweep time is decreased.

Sweep Offset

Transistor Q20, in the sweep attenuator (block O), offsets the sweep ramp in response to the position of the START-CENTER switch (A2A1S7). Normally, the center position is selected and +15V is applied to Q20, holding it off. In the start position, the ST-CTR control line is open and Q20 conducts adding 0.5 mA of current through R70. This develops +5V, which adds to the sweep ramp, offsetting the ramp. The -5V to +5V ramp now becomes a 0V to +10V ramp.

A8 SWEEP GENERATOR/BANDWIDTH CONTROL ASSEMBLY, TROUBLESHOOTING

CAUTION

When making measurements at or near test points, be careful not to short adjacent points or circuit components together.

Auto Scan Time (AST) Accuracy: Observe front panel switch positions to help isolate the problem area. The greater the load placed on the AST line, the greater the current demand. As the current demand increases, the sweep rate will increase.

Failure to Sweep: Check the +10V (nominal) supply. If it is greater than +11.5V, the sweep will be inhibited.

If the +10V (nominal) supply is low, check the Bandwidth Filter No. 1 and No. 2 (A11 and A13) for a shorted crystal filter pole. Test from A11/A13TP2 to ground and A11/A13 to ground with an ohmmeter to locate the possible short.

Begin troubleshooting the sweep generator by determining if the Current Source (block F) is operating and if the Comparator (block H) will toggle.

The inability to trigger retrace, during the beginning of a sweep, is commonly caused by the failure of U1 or CR7.

TABLE 8-8. A8 SWEEP GENERATOR ASSEMBLY, REPLACEABLE PARTS (1 OF 4)

Reference Designation	HP Part Number	C D	Qty	Description	Mfr Code	Mfr Part Number
A8	08558-60173	9	1	SWEEP GENERATOR ASSEMBLY	28480	08558-60173
A8C1	0180-0197	8	5	CAPACITOR-FXD 2.2UF+-10% 20VDC TA	56289	150D225X9020A2
A8C2	0160-3456	6	3	CAPACITOR-FXD 1000PF +-10% 1KVDC CER	28480	0160-3456
A8C3	0160-3402	2	1	CAPACITOR-FXD 1UF +-5% 50VDC MET-POLY C	28480	0160-3402
A8C4	0160-3009	5	1	CAPACITOR-FXD 982PF +-1% 100VDC MICA	28480	0160-3009
A8C5	0180-0197	8		CAPACITOR-FXD 2.2UF+-10% 20VDC TA	56289	150D225X9020A2
A8C6	0160-3466	8	2	CAPACITOR-FXD 100PF +-10% 1KVDC CER	28480	0160-3466
A8C7	0160-2150	5	1	CAPACITOR-FXD 33PF +-5% 300VDC MICA	28480	0160-2150
A8C8	0160-3466	8		CAPACITOR-FXD 100PF +-10% 1KVDC CER	28480	0160-3466
A8C9	0160-2257	3	1	CAPACITOR-FXD 10PF +-5% 500VDC CER 0+-60	28480	0160-2257
A8C10	0170-0066	9	1	CAPACITOR-FXD .027UF +-10% 200VDC POLYE	28480	0170-0066
A8C11	0160-3456	6		CAPACITOR-FXD 1000PF +-10% 1KVDC CER	28480	0160-3456
A8C12	0160-3094	8	2	CAPACITOR-FXD .1UF +-10% 100VDC CER	28480	0160-3094
A8C13	0160-3456	6		CAPACITOR-FXD 1000PF +-10% 1KVDC CER	28480	0160-3456
A8C14	0140-0192	9	1	CAPACITOR-FXD 68PF +-5% 300VDC MICA	72136	DM15E680J0300WV1CR
A8C15	0160-3094	8		CAPACITOR-FXD .1UF +-10% 100VDC CER	28480	0160-3094
A8C16	0160-4297	5	2	CAPACITOR-FXD .022UF +-80-20% 100VDC CER	56289	C023F101H223ZS22-CDH
A8C17	0160-4297	5		CAPACITOR-FXD .022UF +-80-20% 100VDC CER	56289	C023F101H223ZS22-CDH
A8C18				NOT ASSIGNED		
A8C19	0180-0197	8		CAPACITOR-FXD 2.2UF+-10% 20VDC TA	56289	150D225X9020A2
A8C20	0180-0197	8		CAPACITOR-FXD 2.2UF+-10% 20VDC TA	56289	150D225X9020A2
A8C21	0160-0889	3	1	CAPACITOR-FXD .33UF +-10% 80VDC POLYE	28480	0160-0889
A8C22	0160-0168	1	1	CAPACITOR-FXD .1UF +-10% 200VDC POLYE	28480	0160-0168
A8C23	0160-0163	6	1	CAPACITOR-FXD .033UF +-10% 200VDC POLYE	28480	0160-0163
A8C24	0160-0161	4	1	CAPACITOR-FXD .01UF +-10% 200VDC POLYE	28480	0160-0161
A8C25	0160-0155	6	1	CAPACITOR-FXD 3300PF +-10% 200VDC POLYE	28480	0160-0155
A8C26	0160-0945	2	1	CAPACITOR-FXD 710PF +-5% 100VDC MICA	28480	0160-0945
A8C27	0160-0134	1	1	CAPACITOR-FXD 220PF +-5% 300VDC MICA	28480	0160-0134
A8C28	0180-0197	8		CAPACITOR-FXD 2.2UF+-10% 20VDC TA	56289	150D225X9020A2
A8CR1	1901-0050	3	25	DIODE-SWITCHING 80V 200MA 2NS DO-35	28480	1901-0050
A8CR2	1901-0376	6	1	DIODE-GEN PRP 35V 50MA DO-35	28480	1901-0376
A8CR3	1901-0050	3		DIODE-SWITCHING 80V 200MA 2NS DO-35	28480	1901-0050
A8CR4	1901-0050	3		DIODE-SWITCHING 80V 200MA 2NS DO-35	28480	1901-0050
A8CR5	1901-0050	3		DIODE-SWITCHING 80V 200MA 2NS DO-35	28480	1901-0050
A8CR6	1901-0050	3		DIODE-SWITCHING 80V 200MA 2NS DO-35	28480	1901-0050
A8CR7	1901-0539	3	1	DIODE-SM SIG SCHOTTKY	28480	1901-0539
A8CR8	1901-0050	3		DIODE-SWITCHING 80V 200MA 2NS DO-35	28480	1901-0050
A8CR9	1901-0050	3		DIODE-SWITCHING 80V 200MA 2NS DO-35	28480	1901-0050
A8CR10	1901-0050	3		DIODE-SWITCHING 80V 200MA 2NS DO-35	28480	1901-0050
A8CR11	1901-0050	3		DIODE-SWITCHING 80V 200MA 2NS DO-35	28480	1901-0050
A8CR12	1901-0050	3		DIODE-SWITCHING 80V 200MA 2NS DO-35	28480	1901-0050
A8CR13	1901-0050	3		DIODE-SWITCHING 80V 200MA 2NS DO-35	28480	1901-0050
A8CR14	1901-0050	3		DIODE-SWITCHING 80V 200MA 2NS DO-35	28480	1901-0050
A8CR15	1901-0050	3		DIODE-SWITCHING 80V 200MA 2NS DO-35	28480	1901-0050
A8CR16	1901-0050	3		DIODE-SWITCHING 80V 200MA 2NS DO-35	28480	1901-0050
A8CR17	1901-0050	3		DIODE-SWITCHING 80V 200MA 2NS DO-35	28480	1901-0050
A8CR18	1901-0050	3		DIODE-SWITCHING 80V 200MA 2NS DO-35	28480	1901-0050
A8CR19	1901-0050	3		DIODE-SWITCHING 80V 200MA 2NS DO-35	28480	1901-0050
A8CR20	1901-0050	3		DIODE-SWITCHING 80V 200MA 2NS DO-35	28480	1901-0050
A8CR21	1901-0050	3		DIODE-SWITCHING 80V 200MA 2NS DO-35	28480	1901-0050
A8CR22				NOT ASSIGNED		
A8CR23	1901-0050	3		DIODE-SWITCHING 80V 200MA 2NS DO-35	28480	1901-0050
A8CR24				NOT ASSIGNED		
A8CR25	1901-0050	3		DIODE-SWITCHING 80V 200MA 2NS DO-35	28480	1901-0050
A8CR26	1901-0050	3		DIODE-SWITCHING 80V 200MA 2NS DO-35	28480	1901-0050
A8CR27	1901-0050	3		DIODE-SWITCHING 80V 200MA 2NS DO-35	28480	1901-0050
A8CR28	1901-0050	3		DIODE-SWITCHING 80V 200MA 2NS DO-35	28480	1901-0050
A8CR29	1901-0050	3		DIODE-SWITCHING 80V 200MA 2NS DO-35	28480	1901-0050
A8Q1	1854-0637	1	1	TRANSISTOR NPN 2N2219A SI TO-18 PD=800MW	01275	2N2219A
A8Q2	1854-0071	7	32	TRANSISTOR NPN SI PD=300MW FT=200MHZ	28480	1854-0071
A8Q3	1855-0082	2	7	TRANSISTOR J-FET P-CHAN D-MODE SI	28480	1855-0082
A8Q4	1855-0082	2		TRANSISTOR J-FET P-CHAN D-MODE SI	28480	1855-0082
A8Q5	1853-0020	4	6	TRANSISTOR PNP SI PD=300MW FT=150MHZ	28480	1853-0020
A8Q6	1854-0071	7		TRANSISTOR NPN SI PD=300MW FT=200MHZ	28480	1854-0071
A8Q7	1854-0071	7		TRANSISTOR NPN SI PD=300MW FT=200MHZ	28480	1854-0071
A8Q8	1853-0388	7	1	TRANSISTOR-DUAL PNP PD=600MW	28480	1853-0388
A8Q9	1854-0071	7		TRANSISTOR NPN SI PD=300MW FT=200MHZ	28480	1854-0071
A8Q10	1854-0071	7		TRANSISTOR NPN SI PD=300MW FT=200MHZ	28480	1854-0071
A8Q11	1855-0417	7	2	TRANSISTOR J-FET N-CHAN D-MODE TO-18 SI	28480	1855-0417
A8Q12	1853-0020	4		TRANSISTOR PNP SI PD=300MW FT=150MHZ	28480	1853-0020
A8Q13	1854-0071	7		TRANSISTOR NPN SI PD=300MW FT=200MHZ	28480	1854-0071
A8Q14	1854-0484	0	5	TRANSISTOR NPN SI TO-18 PD=360MW	28480	1854-0484
A8Q15	1855-0082	2		TRANSISTOR J-FET P-CHAN D-MODE SI	28480	1855-0082

*Indicates factory selected value

TABLE 8-8. A8 SWEEP GENERATOR ASSEMBLY, REPLACEABLE PARTS (2 OF 4)

Reference Designation	HP Part Number	C D	Qty	Description	Mfr Code	Mfr Part Number
A8Q16	1855-0082	2		TRANSISTOR J-FET P-CHAN D-MODE SI	28480	1855-0082
A8Q17	1855-0082	2		TRANSISTOR J-FET P-CHAN D-MODE SI	28480	1855-0082
A8Q18	1854-0404	0		TRANSISTOR NPN SI TO-18 PD=360MW	28480	1854-0404
A8Q19	1853-0020	4		TRANSISTOR PNP SI PD=300MW FT=150MHZ	28480	1853-0020
A8Q20	1853-0020	4		TRANSISTOR PNP SI PD=300MW FT=150MHZ	28480	1853-0020
A8Q21	1854-0404	0		TRANSISTOR NPN SI TO-18 PD=360MW	28480	1854-0404
A8Q22	1854-0071	7		TRANSISTOR NPN SI PD=300MW FT=200MHZ	28480	1854-0071
A8Q23	1855-0082	2		TRANSISTOR J-FET P-CHAN D-MODE SI	28480	1855-0082
A8Q24	1854-0071	7		TRANSISTOR NPN SI PD=300MW FT=200MHZ	28480	1854-0071
A8Q25	1855-0082	2		TRANSISTOR J-FET P-CHAN D-MODE SI	28480	1855-0082
A8Q26	1854-0071	7		TRANSISTOR NPN SI PD=300MW FT=200MHZ	28480	1854-0071
A8Q27	1854-0071	7		TRANSISTOR NPN SI PD=300MW FT=200MHZ	28480	1854-0071
A8Q28	1854-0071	7		TRANSISTOR NPN SI PD=300MW FT=200MHZ	28480	1854-0071
A8Q29	1855-0414	4	2	TRANSISTOR J-FET 2N4393 N-CHAN D-MODE	04713	2N4393
A8Q30	1854-0071	7		TRANSISTOR NPN SI PD=300MW FT=200MHZ	28480	1854-0071
A8Q31	1854-0071	7		TRANSISTOR NPN SI PD=300MW FT=200MHZ	28480	1854-0071
A8Q32	1854-0071	7		TRANSISTOR NPN SI PD=300MW FT=200MHZ	28480	1854-0071
A8Q33	1854-0404	0		TRANSISTOR NPN SI TO-18 PD=360MW	28480	1854-0404
A8Q34	1854-0071	7		TRANSISTOR NPN SI PD=300MW FT=200MHZ	28480	1854-0071
A8Q35	1854-0071	7		TRANSISTOR NPN SI PD=300MW FT=200MHZ	28480	1854-0071
A8Q36	1853-0020	4		TRANSISTOR PNP SI PD=300MW FT=150MHZ	28480	1853-0020
A8Q37	1855-0417	7		TRANSISTOR J-FET N-CHAN D-MODE TO-18 SI	28480	1855-0417
A8Q38	1854-0404	0		TRANSISTOR NPN SI TO-18 PD=360MW	28480	1854-0404
A8Q39	1854-0071	7		TRANSISTOR NPN SI PD=300MW FT=200MHZ	28480	1854-0071
A8Q40	1853-0020	4		TRANSISTOR PNP SI PD=300MW FT=150MHZ	28480	1853-0020
A8Q41	1854-0071	7		TRANSISTOR NPN SI PD=300MW FT=200MHZ	28480	1854-0071
A8Q42	1854-0071	7		TRANSISTOR NPN SI PD=300MW FT=200MHZ	28480	1854-0071
A8Q43	1854-0071	7		TRANSISTOR NPN SI PD=300MW FT=200MHZ	28480	1854-0071
A8Q44	1854-0071	7		TRANSISTOR NPN SI PD=300MW FT=200MHZ	28480	1854-0071
A8Q45	1854-0071	7		TRANSISTOR NPN SI PD=300MW FT=200MHZ	28480	1854-0071
A8Q46	1854-0071	7		TRANSISTOR NPN SI PD=300MW FT=200MHZ	28480	1854-0071
A8Q47	1854-0071	7		TRANSISTOR NPN SI PD=300MW FT=200MHZ	28480	1854-0071
A8Q48	1854-0071	7		TRANSISTOR NPN SI PD=300MW FT=200MHZ	28480	1854-0071
A8Q49	1854-0071	7		TRANSISTOR NPN SI PD=300MW FT=200MHZ	28480	1854-0071
A8Q50	1854-0071	7		TRANSISTOR NPN SI PD=300MW FT=200MHZ	28480	1854-0071
A8Q51	1854-0071	7		TRANSISTOR NPN SI PD=300MW FT=200MHZ	28480	1854-0071
A8Q52	1854-0071	7		TRANSISTOR NPN SI PD=300MW FT=200MHZ	28480	1854-0071
A8Q53	1854-0071	7		TRANSISTOR NPN SI PD=300MW FT=200MHZ	28480	1854-0071
A8Q54	1854-0071	7		TRANSISTOR NPN SI PD=300MW FT=200MHZ	28480	1854-0071
A8Q55	1854-0071	7		TRANSISTOR NPN SI PD=300MW FT=200MHZ	28480	1854-0071
A8Q56	1855-0414	4		TRANSISTOR J-FET 2N4393 N-CHAN D-MODE	04713	2N4393
ABR1	0698-3450	9	1	RESISTOR 42.2K 1% .125W F TC=0+-100	24546	C4-1/8-T0-4222-F
ABR2	2100-3154	7	1	RESISTOR-TRMR 1K 10% C SIDE-ADJ 17-TRN	02111	43P102
ABR3	0757-0279	0	4	RESISTOR 3.16K 1% .125W F TC=0+-100	24546	C4-1/8-T0-3161-F
ABR4	0757-0419	0	1	RESISTOR 681 1% .125W F TC=0+-100	24546	C4-1/8-T0-681R-F
ABR5	0757-0200	7	1	RESISTOR 5.62K 1% .125W F TC=0+-100	24546	C4-1/8-T0-5621-F
ABR6	0698-7225	4	1	RESISTOR 348 1% .05W F TC=0+-100	24546	C3-1/8-T0-348R-F
ABR7	0757-0442	9		RESISTOR 10K 1% .125W F TC=0+-100	24546	C4-1/8-T0-1002-F
ABR8	0757-0442	9		RESISTOR 10K 1% .125W F TC=0+-100	24546	C4-1/8-T0-1002-F
ABR9	0757-0444	1	2	RESISTOR 12.1K 1% .125W F TC=0+-100	24546	C4-1/8-T0-1212-F
ABR10	2100-3109	2	1	RESISTOR-TRMR 2K 10% C SIDE-ADJ 17-TRN	02111	43P202
ABR11	0698-3457	6		RESISTOR 316K 1% .125W F TC=0+-100	28480	0698-3457
ABR12	0757-0346	2	3	RESISTOR 10 1% .125W F TC=0+-100	24546	C4-1/8-T0-10R0-F
ABR13	2100-3052	4	1	RESISTOR-TRMR 50 10% C SIDE-ADJ 17-TRN	02111	43P500
ABR14	0698-3442	9	1	RESISTOR 237 1% .125W F TC=0+-100	24546	C4-1/8-T0-237R-F
ABR15	0757-0424	7	1	RESISTOR 1.1K 1% .125W F TC=0+-100	24546	C4-1/8-T0-1101-F
ABR16	0757-0279	0		RESISTOR 3.16K 1% .125W F TC=0+-100	24546	C4-1/8-T0-3161-F
ABR17	0698-3444	1	1	RESISTOR 316 1% .125W F TC=0+-100	24546	C4-1/8-T0-316R-F
ABR18	0757-0280	3	1	RESISTOR 1K 1% .125W F TC=0+-100	24546	C4-1/8-T0-1001-F
ABR19	0757-0346	2		RESISTOR 10 1% .125W F TC=0+-100	24546	C4-1/8-T0-10R0-F
ABR20	0757-0465	6	11	RESISTOR 100K 1% .125W F TC=0+-100	24546	C4-1/8-T0-1003-F
ABR21	0698-3451	0	2	RESISTOR 133K 1% .125W F TC=0+-100	24546	C4-1/8-T0-1333-F
ABR22	0757-0459	8	3	RESISTOR 56.2K 1% .125W F TC=0+-100	24546	C4-1/8-T0-5622-F
ABR23	0698-7421	2	3	RESISTOR 40K .25% .125W F TC=0+-100	19701	MF4C1/8-T0-4002-C
ABR24	0698-3194	8	4	RESISTOR 20K .25% .125W F TC=0+-50	03888	PME55-1/8-T2-2002-C
ABR25	0698-7794	2	3	RESISTOR 10K .25% .125W F TC=0+-100	19701	MF4C1/8-T0-1002-C
ABR26	0757-0289	2		RESISTOR 13.3K 1% .125W F TC=0+-100	19701	MF4C1/8-T0-1332-F
ABR27	0757-0199	3	6	RESISTOR 21.5K 1% .125W F TC=0+-100	24546	C4-1/8-T0-2152-F
ABR28	0757-0465	6		RESISTOR 100K 1% .125W F TC=0+-100	24546	C4-1/8-T0-1003-F
ABR29	0698-6360	6	5	RESISTOR 10K .1% .125W F TC=0+-25	28480	0698-6360
ABR30	0698-3934	4	1	RESISTOR 42.16K .1% .125W F TC=0+-25	28480	0698-3934
ABR31	0698-7794	2		RESISTOR 10K .25% .125W F TC=0+-100	19701	MF4C1/8-T0-1002-C
ABR32	0683-3355	2	3	RESISTOR 3.3M 5% .25W FC TC=-900/+1100	01121	CB3355
ABR33	0683-3355	2		RESISTOR 3.3M 5% .25W FC TC=-900/+1100	01121	CB3355
ABR34	0757-0289	2		RESISTOR 13.3K 1% .125W F TC=0+-100	19701	MF4C1/8-T0-1332-F
ABR35	0757-0442	9		RESISTOR 10K 1% .125W F TC=0+-100	24546	C4-1/8-T0-1002-F

*Indicates factory selected value

TABLE 8-8. A8 SWEEP GENERATOR ASSEMBLY, REPLACEABLE PARTS (3 OF 4)

Reference Designation	HP Part Number	C D	Qty	Description	Mfr Code	Mfr Part Number
ABR36	0757-0465	6		RESISTOR 100K 1% .125W F TC=0+-100	24546	C4-1/8-T0-1003-F
ABR37	0757-0465	6		RESISTOR 100K 1% .125W F TC=0+-100	24546	C4-1/8-T0-1003-F
ABR38	0757-0430	7		RESISTOR 51.1K 1% .125W F TC=0+-100	24546	C4-1/8-T0-5112-F
ABR39	0698-6360	6		RESISTOR 10K 1% .125W F TC=0+-25	20480	0698-6360
ABR40	0757-0442	9		RESISTOR 10K 1% .125W F TC=0+-100	24546	C4-1/8-T0-1002-F
ABR41	0698-3160	8	3	RESISTOR 31.6K 1% .125W F TC=0+-100	24546	C4-1/8-T0-3162-F
ABR42*	0698-3935	5	1	RESISTOR 4.946K 1% .125W F TC=0+-25	20480	0698-3935
ABR43	0698-3160	8		RESISTOR 31.6K 1% .125W F TC=0+-100	24546	C4-1/8-T0-3162-F
ABR44	0698-3260	9	2	RESISTOR 464K 1% .125W F TC=0+-100	20480	0698-3260
ABR45	0757-0465	6		RESISTOR 100K 1% .125W F TC=0+-100	24546	C4-1/8-T0-1003-F
ABR46	0757-0439	4	3	RESISTOR 6.81K 1% .125W F TC=0+-100	24546	C4-1/8-T0-6811-F
ABR47*	0698-4037	0	2	RESISTOR 46.4 1% .125W F TC=0+-100	24546	C4-1/8-T0-46R4-F
ABR48	0683-6845	1	1	RESISTOR 680K 5% .25W FC TC=-800/+900	01121	CB6845
ABR49	0698-3457	6		RESISTOR 316K 1% .125W F TC=0+-100	20480	0698-3457
ABR50	0757-0439	4		RESISTOR 6.81K 1% .125W F TC=0+-100	24546	C4-1/8-T0-6811-F
ABR51	0698-4037	0		RESISTOR 46.4 1% .125W F TC=0+-100	24546	C4-1/8-T0-46R4-F
ABR52	0698-3160	8		RESISTOR 31.6K 1% .125W F TC=0+-100	24546	C4-1/8-T0-3162-F
ABR53	0757-0279	0		RESISTOR 3.16K 1% .125W F TC=0+-100	24546	C4-1/8-T0-3161-F
ABR54	0757-0442	9		RESISTOR 10K 1% .125W F TC=0+-100	24546	C4-1/8-T0-1002-F
ABR55	0757-0464	5	1	RESISTOR 90.9K 1% .125W F TC=0+-100	24546	C4-1/8-T0-9092-F
ABR56	0757-0279	0		RESISTOR 3.16K 1% .125W F TC=0+-100	24546	C4-1/8-T0-3161-F
ABR57	0757-0439	4		RESISTOR 6.81K 1% .125W F TC=0+-100	24546	C4-1/8-T0-6811-F
ABR58	0757-0460	1		RESISTOR 61.9K 1% .125W F TC=0+-100	24546	C4-1/8-T0-6192-F
ABR59	0757-0442	9		RESISTOR 10K 1% .125W F TC=0+-100	24546	C4-1/8-T0-1002-F
ABR60	0757-0442	9		RESISTOR 10K 1% .125W F TC=0+-100	24546	C4-1/8-T0-1002-F
ABR61	0757-0465	6		RESISTOR 100K 1% .125W F TC=0+-100	24546	C4-1/8-T0-1003-F
ABR62	0757-0465	6		RESISTOR 100K 1% .125W F TC=0+-100	24546	C4-1/8-T0-1003-F
ABR63				NOT ASSIGNED		
ABR64	0757-0465	6		RESISTOR 100K 1% .125W F TC=0+-100	24546	C4-1/8-T0-1003-F
ABR65	0757-0459	8		RESISTOR 56.2K 1% .125W F TC=0+-100	24546	C4-1/8-T0-5622-F
ABR66	0757-0442	9		RESISTOR 10K 1% .125W F TC=0+-100	24546	C4-1/8-T0-1002-F
ABR67	0698-3154	0	1	RESISTOR 4.22K 1% .125W F TC=0+-100	24546	C4-1/8-T0-4221-F
ABR68*	0698-3457	6	3	RESISTOR 316K 1% .125W F TC=0+-100	20480	0698-3457
ABR69	0757-0440	7	1	RESISTOR 7.5K 1% .125W F TC=0+-100	24546	C4-1/8-T0-7501-F
ABR70	0698-6360	6		RESISTOR 10K 1% .125W F TC=0+-25	20480	0698-6360
ABR71	0757-0442	9		RESISTOR 10K 1% .125W F TC=0+-100	24546	C4-1/8-T0-1002-F
ABR72	2100-2850	8	2	RESISTOR-TRMR 10K 10% WW SIDE-ADJ 20-TRN	02660	3810P-103
ABR73	0698-6360	6		RESISTOR 10K 1% .125W F TC=0+-25	20480	0698-6360
ABR74	0757-0459	8		RESISTOR 56.2K 1% .125W F TC=0+-100	24546	C4-1/8-T0-5622-F
ABR75	0698-7794	2		RESISTOR 10K .25% .125W F TC=0+-100	19701	MF4C1/8-T0-1002-C
ABR76	0698-3238	1	1	RESISTOR 2.5K .25% .125W F TC=0+-50	20480	0698-3238
ABR77	0757-0465	6		RESISTOR 100K 1% .125W F TC=0+-100	24546	C4-1/8-T0-1003-F
ABR78	0698-8827	4	3	RESISTOR 1M 1% .125W F TC=0+-100	20480	0698-8827
ABR79	0698-8827	4		RESISTOR 1M 1% .125W F TC=0+-100	20480	0698-8827
ABR80	0757-0465	6		RESISTOR 100K 1% .125W F TC=0+-100	24546	C4-1/8-T0-1003-F
ABR81	0698-6360	6		RESISTOR 10K 1% .125W F TC=0+-25	20480	0698-6360
ABR82	0698-7404	1	1	RESISTOR 1.005K 1% .125W F TC=0+-50	19701	MF4C1/8-T2-1005R-B
ABR83	0698-7912	6	1	RESISTOR 111.1 .25% .125W F TC=0+-100	19701	MF4C1/8-T0-111R1-C
ABR84	0698-7421	2		RESISTOR 40K .25% .125W F TC=0+-100	19701	MF4C1/8-T0-4002-C
ABR85	2100-2850	8		RESISTOR-TRMR 10K 10% WW SIDE-ADJ 20-TRN	02660	3810P-103
ABR86	0698-3194	8		RESISTOR 20K .25% .125W F TC=0+-50	03088	PME55-1/8-T2-2002-C
ABR87	0757-0461	2	1	RESISTOR 68.1K 1% .125W F TC=0+-100	24546	C4-1/8-T0-6812-F
ABR88	0757-0442	9		RESISTOR 10K 1% .125W F TC=0+-100	24546	C4-1/8-T0-1002-F
ABR89	0757-0442	9		RESISTOR 10K 1% .125W F TC=0+-100	24546	C4-1/8-T0-1002-F
ABR90	0757-0289	2		RESISTOR 13.3K 1% .125W F TC=0+-100	19701	MF4C1/8-T0-1332-F
ABR91	0683-3355	2		RESISTOR 3.3M 5% .25W FC TC=-900/+1100	01121	CB3355
ABR92	0757-0346	2		RESISTOR 10 1% .125W F TC=0+-100	24546	C4-1/8-T0-10R0-F
ABR93	0757-0465	6		RESISTOR 100K 1% .125W F TC=0+-100	24546	C4-1/8-T0-1003-F
ABR94	0757-0199	3		RESISTOR 21.5K 1% .125W F TC=0+-100	24546	C4-1/8-T0-2152-F
ABR95	0698-3157	3	1	RESISTOR 19.6K 1% .125W F TC=0+-100	24546	C4-1/8-T0-1962-F
ABR96	0698-3136	8	1	RESISTOR 17.8K 1% .125W F TC=0+-100	24546	C4-1/8-T0-1782-F
ABR97	0757-1094	9	1	RESISTOR 1.47K 1% .125W F TC=0+-100	24546	C4-1/8-T0-1471-F
ABR98	0757-0289	2		RESISTOR 13.3K 1% .125W F TC=0+-100	19701	MF4C1/8-T0-1332-F
ABR99	0757-0199	3		RESISTOR 21.5K 1% .125W F TC=0+-100	24546	C4-1/8-T0-2152-F
ABR100				NOT ASSIGNED		
ABR101	0757-0199	3		RESISTOR 21.5K 1% .125W F TC=0+-100	24546	C4-1/8-T0-2152-F
ABR102	0698-3451	0		RESISTOR 133K 1% .125W F TC=0+-100	24546	C4-1/8-T0-1333-F
ABR103	0757-0199	3		RESISTOR 21.5K 1% .125W F TC=0+-100	24546	C4-1/8-T0-2152-F
ABR104	0757-0199	3		RESISTOR 21.5K 1% .125W F TC=0+-100	24546	C4-1/8-T0-2152-F
ABR105	0698-0885	0	1	RESISTOR 2.61K 1% .125W F TC=0+-100	24546	C4-1/8-T0-2611-F
ABR106	0698-3260	9		RESISTOR 464K 1% .125W F TC=0+-100	20480	0698-3260
ABR107	0757-0444	1		RESISTOR 12.1K 1% .125W F TC=0+-100	24546	C4-1/8-T0-1212-F
ABR108	0698-3194	8		RESISTOR 20K .25% .125W F TC=0+-50	03088	PME55-1/8-T2-2002-C
ABR109*	0698-3151	7	1	RESISTOR 2.07K 1% .125W F TC=0+-100	24546	C4-1/8-T0-2071-F
ABR110*	0757-0442	9	13	RESISTOR 10K 1% .125W F TC=0+-100	24546	C4-1/8-T0-1002-F

*Indicates factory selected value

TABLE 8-8. A8 SWEEP GENERATOR ASSEMBLY, REPLACEABLE PARTS (4 OF 4)

Reference Designation	HP Part Number	C D	Qty	Description	Mfr Code	Mfr Part Number
ABR111*	0757-0458	7	2	RESISTOR 51.1K 1% .125W F TC=0+-100	24546	C4-1/8-T0-5112-F
ABR112-				NOT ASSIGNED		
ABR115	0757-0460	1	2	RESISTOR 61.9K 1% .125W F TC=0+-100	24546	C4-1/8-T0-6192-F
ABR116*	0698-7421	2		RESISTOR 40K .25% .125W F TC=0+-100	19701	MF4C1/8-T0-4002-C
ABR117						
ABR110*	0757-0209	2	6	RESISTOR 13.3K 1% .125W F TC=0+-100	19701	MF4C1/8-T0-1332-F
ABR119	0698-3194	8		RESISTOR 20K .25% .125W F TC=0+-50	03000	PME55-1/8-T2-2002-C
ABR120*	0698-0172	2	1	RESISTOR 4K .25% .125W F TC=0+-50	19701	MF4C1/8-T2-4001-C
ABR121	0698-7412	1	1	RESISTOR 13.3K .25% .125W F TC=0+-100	19701	MF4C1/8-T0-1332-C
ABR122	0757-0442	7		RESISTOR 10K 1% .125W F TC=0+-100	24546	C4-1/8-T0-1002-F
ABR123	0698-0827	4		RESISTOR 1M 1% .125W F TC=0+-100	20400	0698-0827
ABR124	0757-0209	2		RESISTOR 13.3K 1% .125W F TC=0+-100	19701	MF4C1/8-T0-1332-F
ABTP1	1251-0600	0	9	CONNECTOR-SGL CONT PIN 1.14 MM-BSC-SZ SQ	20400	1251-0600
ABTP2	1251-0600	0		CONNECTOR-SGL CONT PIN 1.14 MM-BSC-SZ SQ	20400	1251-0600
ABTP3	1251-0600	0		CONNECTOR-SGL CONT PIN 1.14 MM-BSC-SZ SQ	20400	1251-0600
ABTP4	1251-0600	0		CONNECTOR-SGL CONT PIN 1.14 MM-BSC-SZ SQ	20400	1251-0600
ABTP5	1251-0600	0		CONNECTOR-SGL CONT PIN 1.14 MM-BSC-SZ SQ	20400	1251-0600
ABTP6	1251-0600	0		CONNECTOR-SGL CONT PIN 1.14 MM-BSC-SZ SQ	20400	1251-0600
ABTP7	1251-0600	0		CONNECTOR-SGL CONT PIN 1.14 MM-BSC-SZ SQ	20400	1251-0600
ABTP8	1251-0600	0		CONNECTOR-SGL CONT PIN 1.14 MM-BSC-SZ SQ	20400	1251-0600
ABTP9	1251-0600	0		CONNECTOR-SGL CONT PIN 1.14 MM-BSC-SZ SQ	20400	1251-0600
ABU1	1020-0223	0	1	IC OP AMP GP TO-99 PKG	3L505	CA301A1
ABU2	1026-0092	3	1	IC OP AMP GP DUAL TO-99 PKG	20400	1026-0092
ABU3	1026-1058	3	1	IC OP AMP GP 8-TO-99 PKG	20400	1026-1058
ABU4	1010-0212	6	3	NETWORK-RES 16-DIP22.0K OHM X 8	01121	316B223
ABU5	1010-0212	6		NETWORK-RES 16-DIP22.0K OHM X 8	31121	316B223
ABU6	1010-0212	6		NETWORK-RES 16-DIP22.0K OHM X 8	01121	316B223
ABU7	1010-0207	9	1	NETWORK-RES 8-SIP22.0K OHM X 7	01121	208A223
ABVR1	1902-0025	4	1	DIODE-ZNR 10V 5% DO-35 PD=.4W TC=+.06%	20400	1902-0025
ABVR2	1902-3139	7	2	DIODE-ZNR 8.25V 5% DO-35 PD=.4W	20400	1902-3139
ABVR3	1902-0049	2	1	DIODE-ZNR 6.19V 5% DO-35 PD=.4W	20400	1902-0049
ABVR4	1902-3139	7		DIODE-ZNR 8.25V 5% DO-35 PD=.4W	20400	1902-3139
ABVR5	1902-0041	4	1	DIODE-ZNR 5.11V 5% DO-35 PD=.4W	20400	1902-0041
				MISCELLANEOUS		
	0300-1563	8	1	STANDOFF-RND .5-IN-LG 8-32-THD .25-IN-OD	20400	0300-1563
	1200-0173	5	1	INSULATOR-XSTR DAP-GL	20400	1200-0173
	2510-0140	4	1	SCREW-MACH 8-32 .25-IN-LG FIL-HD-SLT	00000	ORDER BY DESCRIPTION

*Indicates factory selected value

A8
SWEEP GENERATOR/BANDWIDTH CONTROL ASSEMBLY
08558-60173

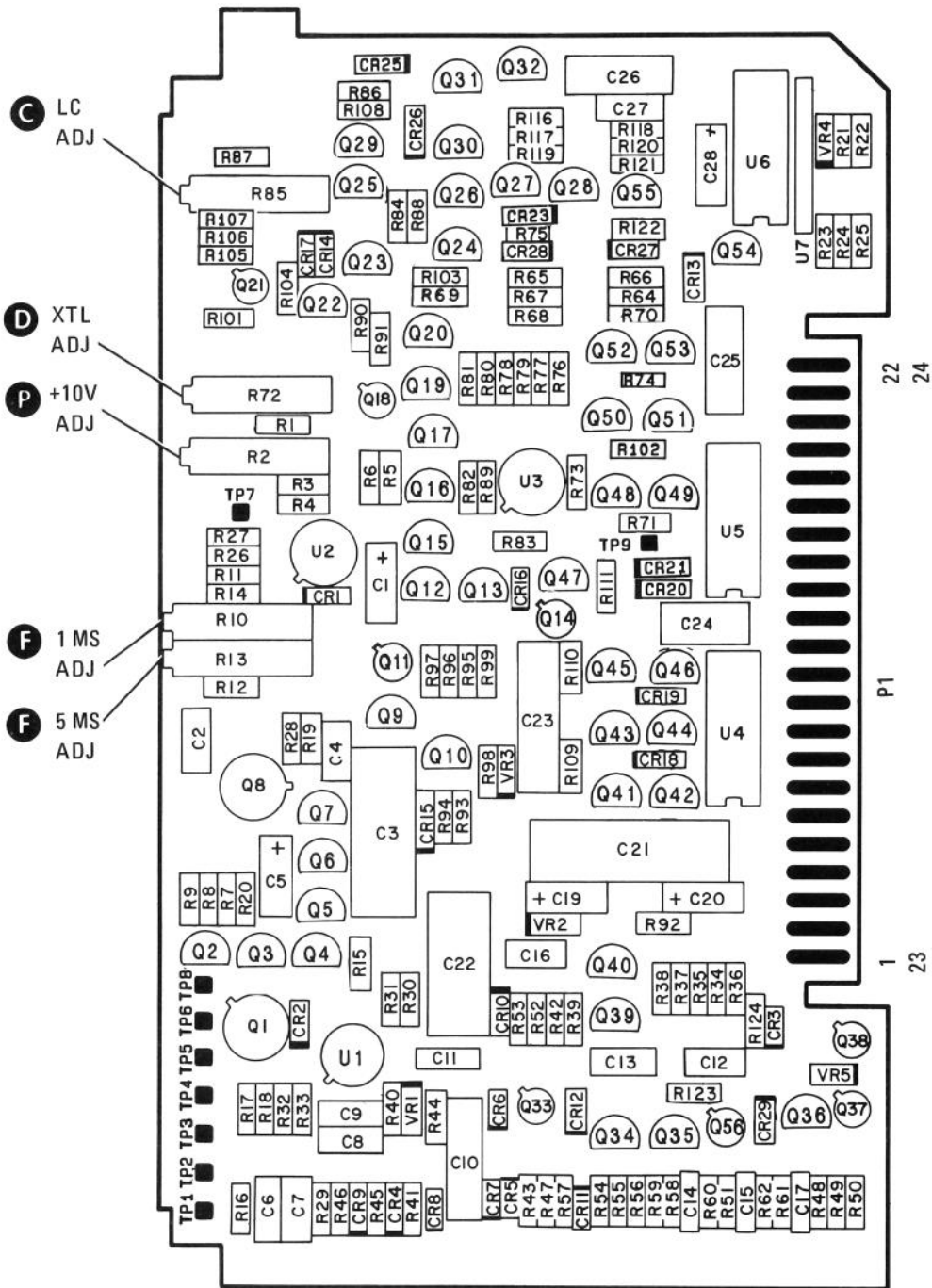

FIGURE 8-29. A8 SWEEP GENERATOR ASSEMBLY, COMPONENT LOCATIONS

A9 THIRD CONVERTER, CIRCUIT DESCRIPTION

General Description

The Third Converter Assembly consists of a 280 MHz oscillator followed by a buffer amplifier, a balanced mixer, a matching filter, a 21.4 MHz amplifier, and a PIN attenuator. The 301.4 MHz second IF signal from A10 is mixed with the 280 MHz oscillator (third LO) in balanced mixer A9U1. The output from the mixer is the difference frequency, 21.4 MHz, which is applied to the matching filter. This is a 21.4 MHz bandpass filter which also acts as an inter-stage impedance matching device. The signal is then amplified by the 21.4 MHz amplifier and coupled to a divider network consisting of two PIN diodes A9CR3 and CR4, resistor R25, and the input impedance of the Bandwidth Filter No. 1 Assembly A11. PIN driver A9Q5 changes the bias of the PIN diodes as a function of frequency, compensating for input mixer frequency response. The 21.4 MHz third IF output signal is coupled to the input of Bandwidth Filter No. 1. The 280 MHz Oscillator also provides the front panel CAL OUTPUT 280 MHz – 30 dBm signal. It is sometimes necessary to select a different value for R9 to provide the – 30 dBm CAL OUTPUT level while maintaining the proper input level to the balanced mixer.

280 MHz Oscillator (Third LO) (A)

The third local oscillator is a modified Colpitts circuit with a 280 MHz surface acoustic wave resonator (SAWR) A9Z1 in the positive feedback path to provide increased frequency stability. Inductor A9L3, across the SAWR, tunes out the SAWR shunt capacitance. The oscillator-tuned circuit consists of capacitors A9C4, C5, and inductors L4 and L6. This tuned circuit ensures that the oscillator oscillates only on the proper overtone of the SAWR. Although A9L4 is called the LO FREQ adjustment, it is used to adjust for maximum LO output power and has only a slight effect on the output frequency. Inductor A9L5 provides a dc path for the base bias of buffer amplifier A9Q2. Diodes A9CR1 and CR2 provide temperature compensation for the 280 MHz oscillator and indirectly stabilize the CAL OUTPUT level. Power is taken out of the oscillator through L6, which transforms the output to approximately 50 ohms at a level of 0 dBm. The output level of the circuit is controlled by 3RD LO PWR adjustment A9R5, which sets the emitter current of A9Q1 and allows adjustment for a – 30 dBm 280 MHz front-panel CAL OUTPUT level. It is sometimes necessary to select a different value for A9R4 to provide the proper third LO output level. Buffer amplifier A9Q2 provides isolation for the 280 MHz oscillator and provides about 10 dB of power gain to the L port of balanced mixer U1. The buffer amplifier also provides the proper output level to the front-panel CAL OUTPUT (by selecting A9R9) for a given balanced mixer input.

Balanced Mixer (Third Mixer) (C)

The third LO 280 MHz input to the L port of the balanced mixer is approximately + 10 dBm. The level of the second IF 301.4 MHz input to the X port of the mixer is about – 12 dBm or less. The third mixer output (Port R) is the 21.4 MHz difference frequency produced by heterodyning the 301.4 MHz IF and the 280 MHz LO. The third mixer has a conversion loss of about 7 dB.

Matching Filter (D)

The output of the balanced mixer is applied to the matching filter which consists of A9L9, C10, C11, C12, and L10. The matching filter is a 21.4 MHz bandpass filter which also serves as an impedance matching network. The circuit raises the low input impedance of the 21.4 MHz amplifier (about 10 ohms) to match the higher output impedance of the balanced mixer (about 50 ohms).

21.4 MHz Amplifier (E)

The 21.4 MHz amplifier consists of A9Q3 in a common-emitter configuration and A9Q4 as an emitter follower. Transistor A9Q3 employs resistor A9R12 and zener diode A9VR2 to furnish base bias and negative feedback for gain control and stabilization. Resistor A9R12 is factory selected to provide the proper gain of the Third

Converter Assembly. Capacitor A9C14 is connected across A9VR2 to reduce noise. The output of the 21.4 MHz amplifier looks into a voltage-controlled attenuator consisting of two PIN diodes, A9CR3 and CR4, resistor A9R25, and the input impedance of the Bandwidth Filter No. 1 Assembly A11.

PIN Driver (F)

The PIN diode resistance of A9CR3 and CR4 is controlled by the PIN driver A9Q5 and its associated circuitry. The base of A9Q5 is the summing point for the frequency analog voltage from the Frequency Control Assembly A7 and a dc level set by front-panel REF LEVEL CAL screwdriver adjustment A2R3. Setting the dc level by adjusting A2R3 calibrates the 8558B display at a given frequency, usually performed at 280 MHz. The frequency analog voltage is a dc level varying from +0.6V to +6.7V as a function of frequency. This frequency analog voltage at the base of A9Q5 compensates for input mixer response. SLOPE COMP adjustment A9R1 sets the amount of compensation required for a flat frequency response. The total current through the PIN diodes A9CR3 and CR4 is shaped by the emitter network of A9Q5. This network provides a change in current through the PIN diodes to cause a change of PIN diode resistance. The change in resistance is required to provide the proper log curve within an 8 dB range for the voltage controlled attenuator.

A10 SECOND IF, CIRCUIT DESCRIPTION

General Description

The Second IF Assembly contains a bandpass amplifier which provides a gain of approximately 16 dB at 301.4 MHz. It also contains a bandpass filter which provides further rejection of unwanted signals. The bandpass filter has a 3 dB loss, giving the Second IF Assembly a net gain of approximately 13 dB at 301.4 MHz. The 301.4 MHz IF output signal is coupled to Third Converter Assembly A9 by cable W7. This signal is the input to the X port of the balanced mixer on the Third Converter Assembly.

Bandpass Amplifier (A)

The bandpass amplifier consists of A10Q2 in a common-emitter configuration, and A10Q1 connected to control the base drive and bias current of A10Q2. Capacitors A10C4, C5, C7, and C10 serve as decoupling for high frequencies. The gain of the bandpass amplifier is set by the high frequency characteristics of A10Q2, R5, and the small amount of inductance on the emitter connection of Q2. The emitter inductance is used to establish a 50 ohm input impedance and to help stabilize the current gain of A10Q2. Resistor A10R5 in parallel with the output resistance of A10Q2 establishes an output impedance of about 500 ohms. Components A10L2, C8, C9 and the collector capacitance (C_c) of Q2 form the collector tank circuit (see Figure 8-31). This tank circuit determines the center frequency of the bandpass amplifier and transforms the 500 ohm output impedance at the collector of A10Q1 down to 50 ohms. The output of the bandpass amplifier flows from A10C9 through a 50 ohm microstrip transmission line (etched on the printed circuit board) to the bandpass filter. The bandpass amplifier has a gain of about 16 dB from the base of A10Q2 to the 50 ohm output of A10C9.

Bandpass Filter (B)

The output of the bandpass amplifier passes through a 301.4 MHz bandpass filter. The bandpass filter is made up of A10L3, L4, L5, C11, C12, C13, C14, C15, and adjustable piston-type capacitors A10C1, C2, and C3. Capacitors A10C11 and C15 are used to transform the bandpass filter input and output impedance to 50 ohms. Inductors A10L3, L4, and L5 are wound on a common coil form which provides mutual inductance coupling between filter sections. The bandpass filter has an insertion loss of approximately 3 dB and a 3 dB bandwidth of about 12 MHz.

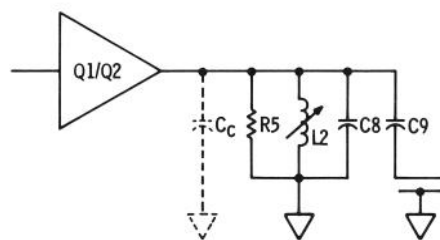

FIGURE 8-31. BANDPASS AMPLIFIER TANK CIRCUIT, SIMPLIFIED SCHEMATIC

TABLE 8-9. A9 THIRD CONVERTER ASSEMBLY, REPLACEABLE PARTS (1 OF 2)

Reference Designation	HP Part Number	C D	Qty	Description	Mfr Code	Mfr Part Number
A9	08558-60154 08558-60155	6 7	1 1	THIRD CONVERTER ASSEMBLY THIRD CONVERTER ASSEMBLY (OPTION 001, 002)	28480 28480	08558-60154 08558-60155
A9C1	0160-3878	6	8	CAPACITOR-FXD 1000PF +-20% 100VDC CER	28480	0160-3878
A9C2	0160-3878	6		CAPACITOR-FXD 1000PF +-20% 100VDC CER	28480	0160-3878
A9C3	0160-3878	6		CAPACITOR-FXD 1000PF +-20% 100VDC CER	28480	0160-3878
A9C4	0160-2249	3	1	CAPACITOR-FXD 4.7PF +--.25PF 500VDC CER	28480	0160-2249
A9C5	0160-2264	2	1	CAPACITOR-FXD 20PF +-5% 500VDC CER 0+-30	28480	0160-2264
A9C6	0160-3878	6		CAPACITOR-FXD 1000PF +-20% 100VDC CER	28480	0160-3878
A9C7	0160-3878	6		CAPACITOR-FXD 1000PF +-20% 100VDC CER	28480	0160-3878
A9C8	0160-3878	6		CAPACITOR-FXD 1000PF +-20% 100VDC CER	28480	0160-3878
A9C9	0160-3878	6		CAPACITOR-FXD 1000PF +-20% 100VDC CER	28480	0160-3878
A9C10	0160-2207	3	1	CAPACITOR-FXD 300PF +-5% 300VDC MICA	28480	0160-2207
A9C11	0140-0195	2	1	CAPACITOR-FXD 130PF +-5% 300VDC MICA	72136	DM15F131J0300WV1CR
A9C12	0140-0198	5	1	CAPACITOR-FXD 200PF +-5% 300VDC MICA	72136	DM15F201J0300WV1CR
A9C13	0180-0197	8	2	CAPACITOR-FXD 2.2UF+-10% 20VDC TA	56289	150D225X9020A2
A9C14	0180-0197	8		CAPACITOR-FXD 2.2UF+-10% 20VDC TA	56289	150D225X9020A2
A9C15	0160-3878	6		CAPACITOR-FXD 1000PF +-20% 100VDC CER	28480	0160-3878
A9C16	0160-3456	6	1	CAPACITOR-FXD 1000PF +-10% 1KVDC CER	28480	0160-3456
A9C17	0160-3879	7	4	CAPACITOR-FXD .01UF +-20% 100VDC CER	28480	0160-3879
A9C18	0160-3879	7		CAPACITOR-FXD .01UF +-20% 100VDC CER	28480	0160-3879
A9C19	0160-3879	7		CAPACITOR-FXD .01UF +-20% 100VDC CER	28480	0160-3879
A9C20	0160-3879	7		CAPACITOR-FXD .01UF +-20% 100VDC CER	28480	0160-3879
A9CR1	1901-0040	1	4	DIODE-SWITCHING 30V 50MA 2NS DO-35	28480	1901-0040
A9CR2	1901-0040	1		DIODE-SWITCHING 30V 50MA 2NS DO-35	28480	1901-0040
A9CR3	1901-1070	9	4	DIODE-PIN 110V	28480	1901-1070
A9CR4	1901-1070	9		DIODE-PIN 110V	28480	1901-1070
A9CR5	1901-0040	1		DIODE-SWITCHING 30V 50MA 2NS DO-35	28480	1901-0040
A9CR6	1901-0040	1		DIODE-SWITCHING 30V 50MA 2NS DO-35	28480	1901-0040
A9CR7	1901-1070	9		DIODE-PIN 110V	28480	1901-1070
A9CR8	1901-1070	9		DIODE-PIN 110V	28480	1901-1070
A9E1	9170-0029	3	1	CORE-SHIELDING BEAD	28480	9170-0029
A9J1	1250-0830	6	2	CONNECTOR-RF SMC M SGL-HOLE-FR 50-OHM	28480	1250-0830
A9J2	1250-0830	6		CONNECTOR-RF SMC M SGL-HOLE-FR 50-OHM	28480	1250-0830
A9L1	9100-2255	4	5	INDUCTOR RF-CH-MLD 470NH 10% .105DX.26LG	28480	9100-2255
A9L2	9100-2255	4		INDUCTOR RF-CH-MLD 470NH 10% .105DX.26LG	28480	9100-2255
A9L3	08558-80002	5	1	COIL NEUTRALIZING	28480	08558-80002
A9L4	08558-80012	7	1	COIL FREQ ADJUST	28480	08558-80012
A9L5	9100-2255	4		INDUCTOR RF-CH-MLD 470NH 10% .105DX.26LG	28480	9100-2255
A9L6	9100-2250	9	1	INDUCTOR RF-CH-MLD 180NH 10% .105DX.26LG	28480	9100-2250
A9L7	9100-2255	4		INDUCTOR RF-CH-MLD 470NH 10% .105DX.26LG	28480	9100-2255
A9L8	9100-2255	4		INDUCTOR RF-CH-MLD 470NH 10% .105DX.26LG	28480	9100-2255
A9L9	9100-2249	6	2	INDUCTOR RF-CH-MLD 150NH 10% .105DX.26LG	28480	9100-2249
A9L10	9100-2249	6		INDUCTOR RF-CH-MLD 150NH 10% .105DX.26LG	28480	9100-2249
A9L11	9100-2276	9	1	INDUCTOR RF-CH-MLD 100UH 10% .105DX.26LG	28480	9100-2276
A9L12	9140-0178	0	2	INDUCTOR RF-CH-MLD 12UH 10% .166DX.385LG	28480	9140-0178
A9L13	9140-0178	0		INDUCTOR RF-CH-MLD 12UH 10% .166DX.385LG	28480	9140-0178
A9L14	9140-0143	9	1	INDUCTOR RF-CH-MLD 3.3UH 10% .105DX.26LG	28480	9140-0143
A9L15	9100-1623	8	2	INDUCTOR RF-CH-MLD 27UH 5% .166DX.385LG	28480	9100-1623
A9L16	9100-1623	8		INDUCTOR RF-CH-MLD 27UH 5% .166DX.385LG	28480	9100-1623
A9Q1	1854-0345	8	1	TRANSISTOR NPN 2N5179 SI TO-72 PD=200MW	04713	2N5179
A9Q2	1854-0247	9	2	TRANSISTOR NPN SI TO-39 PD=1W FT=800MHZ	28480	1854-0247
A9Q3	1854-0247	9		TRANSISTOR NPN SI TO-39 PD=1W FT=800MHZ	28480	1854-0247
A9Q4	1854-0019	3	1	TRANSISTOR NPN SI TO-18 PD=360MW	28480	1854-0019
A9Q5	1854-0404	0	1	TRANSISTOR NPN SI TO-18 PD=360MW	28480	1854-0404
A9R1	2100-2522	1	1	RESISTOR-TRMR 10K 10% C SIDE-ADJ 1-TRN	30983	ET50X103
A9R2	0757-0280	3	2	RESISTOR 1K 1% .125W F TC=0+-100	24546	C4-1/8-T0-1001-F
A9R3	0757-0346	2	3	RESISTOR 10 1% .125W F TC=0+-100	24546	C4-1/8-T0-10R0-F
A9R4*	0757-0424	7	1	RESISTOR 1.1K 1% .125W F TC=0+-100	24546	C4-1/8-T0-1101-F
A9R5	2100-3123	0	1	RESISTOR-TRMR 500 10% C SIDE-ADJ 17-TRN	02111	43P501
A9R6	0757-0346	2	2	RESISTOR 10 1% .125W F TC=0+-100	24546	C4-1/8-T0-10R0-F
A9R7	0757-0346	2		RESISTOR 10 1% .125W F TC=0+-100	24546	C4-1/8-T0-10R0-F
A9R8	0757-0799	9	1	RESISTOR 121 1% .5W F TC=0+-100	28480	0757-0799
A9R9	0757-0274	5	1	RESISTOR 1.21K 1% .125W F TC=0+-100	24546	C4-1/8-T0-1211-F
A9R10	0698-7188	8	1	RESISTOR 10 1% .05W F TC=0+-100	24546	C3-1/8-T0-10R-F
A9R10	0698-7196	8	1	RESISTOR 21.5 1% .05W F TC=0+-100 (OPTION 001, 002)	24546	C3-1/8-T0-21R5-F
A9R11	0698-7203	8	1	RESISTOR 42.2 1% .05W F TC=0+-100	24546	C3-1/8-T0-42R2-F
A9R11	0698-7206	1	1	RESISTOR 56.2 1% .05W F TC=0+-100 (OPTION 001, 002)	24546	C3-1/8-T0-56R2-F
A9R12*	0757-0416	7	1	RESISTOR 511 1% .125W F TC=0+-100	24546	C4-1/8-T0-511R-F
A9R13	0698-3450	9	1	RESISTOR 42.2K 1% .125W F TC=0+-100	24546	C4-1/8-T0-4222-F

*Indicates factory selected value

TABLE 8-9. A9 THIRD CONVERTER ASSEMBLY, REPLACEABLE PARTS (2 OF 2)

Reference Designation	HP Part Number	C D	Qty	Description	Mfr Code	Mfr Part Number
A9R14*	0757-0463	4	1	RESISTOR 82.5K 1% .125W F TC=0+-100	24546	C4-1/8-T0-8252-F
A9R15	0698-3438	3	1	RESISTOR 147 1% .125W F TC=0+-100	24546	C4-1/8-T0-147R-F
A9R16	0683-0475	1	1	RESISTOR 4.7 5% .25W FC TC=-400/+500	01121	CB47G5
A9R17	0757-0464	5	1	RESISTOR 90.9K 1% .125W F TC=0+-100	24546	C4-1/8-T0-9092-F
A9R18	0698-3150	6	1	RESISTOR 2.37K 1% .125W F TC=0+-100	24546	C4-1/8-T0-2371-F
A9R19	0698-3156	2	1	RESISTOR 14.7K 1% .125W F TC=0+-100	24546	C4-1/8-T0-1472-F
A9R20	0757-0418	9	2	RESISTOR 619 1% .125W F TC=0+-100	24546	C4-1/8-T0-619R-F
A9R21	0698-3159	5	1	RESISTOR 26.1K 1% .125W F TC=0+-100	24546	C4-1/8-T0-2612-F
A9R22	0757-0317	7	1	RESISTOR 1.33K 1% .125W F TC=0+-100	24546	C4-1/8-T0-1331-F
A9R23	0698-3447	4	1	RESISTOR 422 1% .125W F TC=0+-100	24546	C4-1/8-T0-422R-F
A9R24	0757-0280	3		RESISTOR 1K 1% .125W F TC=0+-100	24546	C4-1/8-T0-1001-F
A9R25	0757-0418	9		RESISTOR 619 1% .125W F TC=0+-100	24546	C4-1/8-T0-619R-F
A9U1	0755-0076	5	1	MIXER-DOUBLE BALANCE .05 TO 500 MHZ	28480	0755-0076
A9VR1	1902-3104	6	1	DIODE-ZNR 5.62V 5% D0-35 PD=.4W	28480	1902-3104
A9VR2	1902-0025	4	1	DIODE-ZNR 10V 5% D0-35 PD=.4W TC=+.06%	28480	1902-0025
A9Z1	1GA1-8001	3	1	SAWR 280 MHZ	28480	1GA1-8001
				MISCELLANEOUS		
	0360-0452	0	2	TERMINAL-SLDR LUG PL-MTG FOR-#10-SCR	28480	0360-0452
	08558-00014	1	1	COVER 3RD CONV	28480	08558-00014
	1200-0173	5	4	INSULATOR-XSTR DAP-GL	28480	1200-0173
	2190-0124	4	2	WASHER-LK INTL T NO. 10 .175-IN-ID	28480	2190-0124
	2200-0101	0	2	SCREW-MACH 4-40 .188-IN-LG PAN-HD-POZI	60000	ORDER BY DESCRIPTION
	2950-0078	9	2	NUT-HEX-DBL-CHAM 10-32-THD .067-IN-THK	28480	2950-0078
	08558-00079	8	1	RF SHIELD-MIXER	28480	08558-00079
	1200-0173	5		INSULATOR-XSTR DAP-GL	28480	1200-0173

*Indicates factory selected value

TABLE 8-10. A10 SECOND IF ASSEMBLY, REPLACEABLE PARTS

Reference Designation	HP Part Number	C D	Qty	Description	Mfr Code	Mfr Part Number
A10	8558-60010	3	1	SECOND IF ASSEMBLY	28480	8558-60010
A10C1	0121-0457	9	3	CAPACITOR-V TRMR-PSTN .8-8.5PF 750V	18736	TP?
A10C2	0121-0457	9		CAPACITOR-V TRMR-PSTN .8-8.5PF 750V	18736	TP?
A10C3	0121-0457	9		CAPACITOR-V TRMR-PSTN .8-8.5PF 750V	18736	TP?
A10C4	0160-3878	6	4	CAPACITOR-FXD 1000PF +-20% 100VDC CER	28480	0160-3878
A10C5	0160-3878	6		CAPACITOR-FXD 1000PF +-20% 100VDC CER	28480	0160-3878
A10C6	0160-3877	5	1	CAPACITOR-FXD 100PF +-20% 200VDC CER	28480	0160-3877
A10C7	0160-3878	6		CAPACITOR-FXD 1000PF +-20% 100VDC CER	28480	0160-3878
A10C8	0160-2236	8	1	CAPACITOR-FXD 1PF +- .25PF 500VDC CER	28480	0160-2236
A10C9	0160-2250	6	5	CAPACITOR-FXD 5.1PF +- .25PF 500VDC CER	28480	0160-2250
A10C10	0160-3878	6		CAPACITOR-FXD 1000PF +-20% 100VDC CER	28480	0160-3878
A10C11	0160-2250	6		CAPACITOR-FXD 5.1PF +- .25PF 500VDC CER	28480	0160-2250
A10C12	0160-2250	6		CAPACITOR-FXD 5.1PF +- .25PF 500VDC CER	28480	0160-2250
A10C13	0160-2252	8	1	CAPACITOR-FXD 6.2PF +- .25PF 500VDC CER	28480	0160-2252
A10C14	0160-2250	6		CAPACITOR-FXD 5.1PF +- .25PF 500VDC CER	28480	0160-2250
A10C15	0160-2250	6		CAPACITOR-FXD 5.1PF +- .25PF 500VDC CER	28480	0160-2250
A10L1	7130-2247	4	1	INDUCTOR RF-CH-MLD 100NH 10% .105DX.26LG	28480	7130-2247
A10L2	8858-80005	8	1	COIL PAR TANK	28480	8858-80005
A10L3	8858-80003	6	3	COIL B. P. FILTER	28480	8858-80003
A10L4	8858-80003	6		COIL B. P. FILTER	28480	8858-80003
A10L5	8858-80003	6		COIL B. P. FILTER	28480	8858-80003
A10Q1	1853-0007	7	1	TRANSISTOR PNP 2N3251 SI TO-18 PD=360MW	04713	2N3251
A10Q2	5086-4218	7	1	TC21 IN TO-72 PKG	28480	5086-4218
A10R1	0757-0442	9	1	RESISTOR 10K 1% .125W F TC=0+-100	24546	C4-1/8-T0-1002-F
A10R2	0698-3136	8	1	RESISTOR 17.8K 1% .125W F TC=0+-100	24546	C4-1/8-T0-1782-F
A10R3	0757-0438	3	1	RESISTOR 5.11K 1% .125W F TC=0+-100	24546	C4-1/8-T0-5111-F
A10R4	0698-3442	9	1	RESISTOR 237 1% .125W F TC=0+-100	24546	C4-1/8-T0-237R-F
A10R5	0757-0280	3	1	RESISTOR 1K 1% .125W F TC=0+-100	24546	C4-1/8-T0-1001-F
MISCELLANEOUS						
	1200-0172	4	1	INSULATOR-XSTR DAP-GL	28480	1200-0172
	0360-0452	0	2	TERMINAL-SLDR LUG PL-MTG FOR-#10-SCR	28480	0360-0452
	8858-00015	2	1	COVER 2ND I.F.	28480	8858-00015
	1250-0830	6	2	CONNECTOR-RF SMC M SGL-HOLE-FR 50-OHM	28480	1250-0830
	2190-0124	4	2	WASHER-LK INTL T NO. 10 .175-IN-ID	28480	2190-0124
	2200-0101	0	2	SCREW-MACH 4-40 .188-IN-LG PAN-HD-POZI	00000	ORDER BY DESCRIPTION
	2950-0078	9	2	NUT-HEX-DBL-CHAM 10-32-THD .067-IN-THK	28480	2950-0078

*Indicates factory selected value

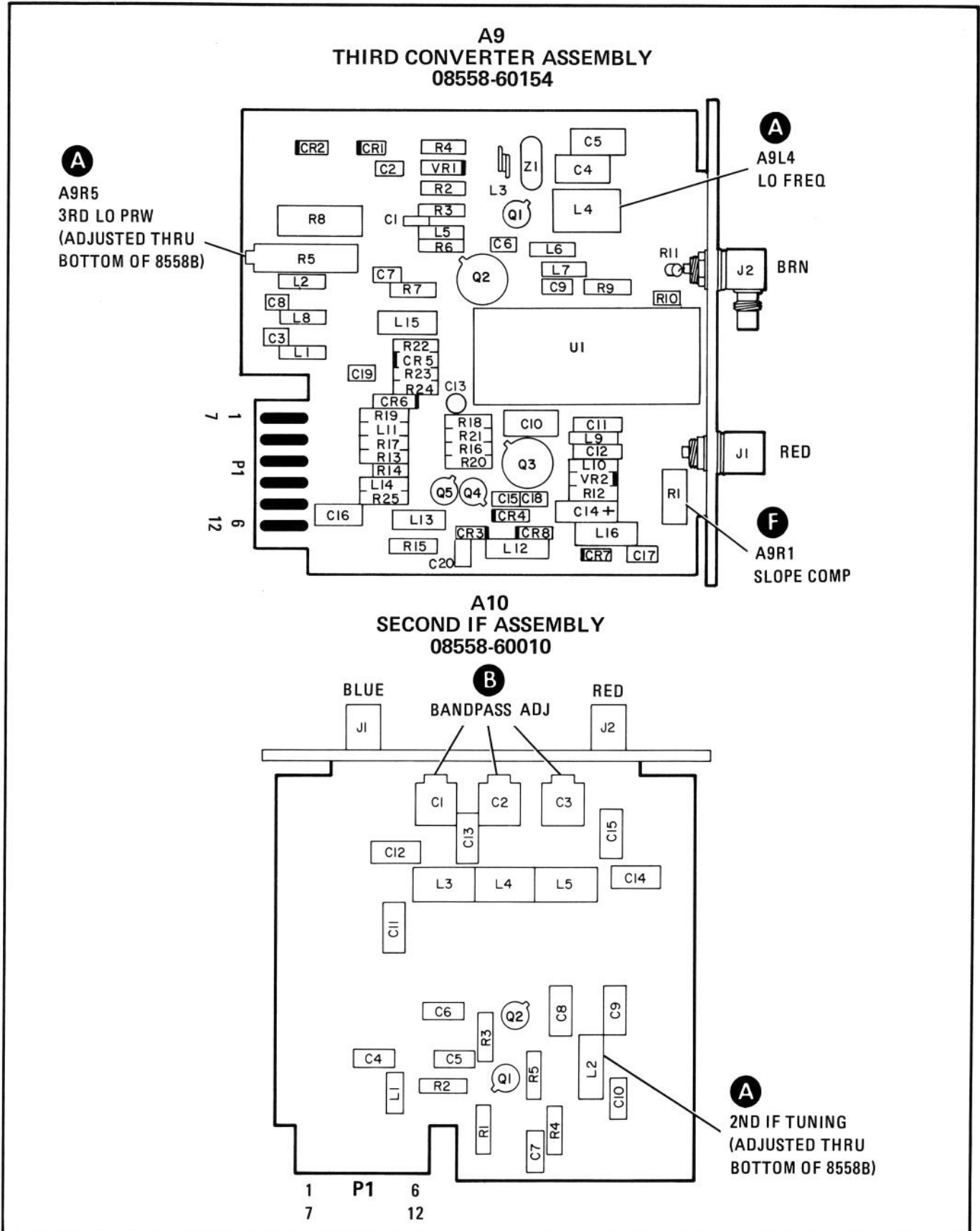

FIGURE 8-32. A9 THIRD CONVERTER AND A10 SECOND IF ASSEMBLIES, COMPONENT LOCATIONS

A11 BANDWIDTH FILTER NO. 1, CIRCUIT DESCRIPTION

General Description

Bandwidth Filter Assemblies No. 1 and No. 2, A11 and A13, are identical except for some off-board connections. The following description applies to both assemblies. The Bandwidth Filter Assemblies operate at 21.4 MHz with a variable bandwidth from 1 kHz to 3 MHz. The front-panel RESOLUTION BW switch selects one of the following eight available bandwidths: 3 MHz, 1 MHz, 300 kHz, 100 kHz, 30 kHz, 10 kHz, 3 kHz, or 1 kHz.

Four stages of filtering are used for all eight bandwidths; each assembly contains two stages. The bandwidths from 1 kHz to 30 kHz are obtained from synchronously-tuned crystal filters; the remaining four bandwidths (100 kHz to 3 MHz) use synchronously-tuned LC tank circuits. The four crystal-filter stages contain factory-selected matched crystals (A11Y1, A11Y2, A13Y1, and A13Y2) that must be replaced as a set. If replacement of a bandwidth filter assembly is necessary, the new assembly is shipped with two crystals installed and two packaged separately to replace the crystals on the other assembly. In addition to the filter stages, each board contains: a 10 dB Buffer Amplifier, a Unity Gain Buffer Amplifier, and an Output Buffer Amplifier.

10 dB Input Buffer Amplifier (B)

The 10 dB Input Buffer Amplifier is shown as a non-inverting operational amplifier in Figure 8-34. Gain for the amplifier is expressed in the equation: $\text{Gain} = 1 + R_f/R_{in}$. The total resistance of R5, R6, and R7 forms the feedback path (R_f); R3 forms the input resistance (R_{in}). This ac model of the amplifier's operation is true for all but the narrowest bandwidths, as illustrated later.

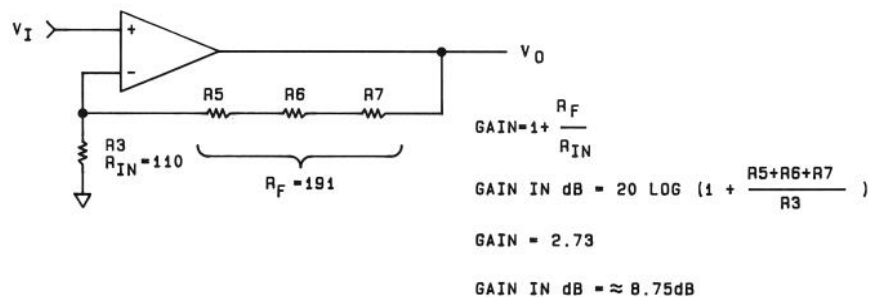

FIGURE 8-34. 10 dB INPUT BUFFER AMPLIFIER GAIN MODEL

Two current paths are used for dc bias in the input buffer amplifier: one for crystal filter poles, another for LC filter poles. When a crystal-filtered bandwidth (≤ 30 kHz) is selected, Q3 (block **(D)**) and Q1 are the sources for the current through Q2 (see Figure 8-35). The base voltage of Q2 is fixed by the divider R9 and R10 while the emitter is fixed by R8. The collector, therefore, becomes a constant-current sink for 20 mA of current supplied by Q1 and Q3. A decrease in the current supplied by Q3 results in increased current through Q1, keeping the current through Q2 constant. If an LC-filtered bandwidth is selected, BW5F (filtered bandwidth control line 5 in block **(C)**) supplies current via CR1 and R13 (see Figure 8-36); Q3 is effectively removed from the circuit.

To understand how Q3 functions during crystal filtering modes, a new model is needed. (See Figure 8-37). Resistor R7 has been omitted to simplify the model. The emitter load of Q3 (R_e) is the series combination of the internal resistance of Y1 (R_s) and a resistance determined by the bandwidth selected (see First Xtal Pole description). The crystal's series resistance at resonance (R_s) is constant at about 10 ohms. In the 30 kHz bandwidth, R23* is in series with R_s . Since R23* is very large by comparison, it represents the total load on Q3 (R_e). When R23* is substituted into the gain equation for R_e , a gain of 2.7 (8.6 dB) results. This is roughly equal to the gain without Q3 in the circuit. In fact, the larger R_e becomes, the closer the gains become.

When the 1 kHz bandwidth is selected, CR4 is biased on and has a resistance of about 60 ohms. This resistance forms a voltage divider with R_5 and results in signal amplitude loss across the crystal. Increased gain in the input buffer amplifier, caused by the load on Q3, compensates for these losses. The gain increase occurs when the reduction in the R_5 turns Q3 on even harder, resulting in some of the feedback from R6 being shunted to ground through the collector of Q3. This reduction in negative feedback increases the gain of the input buffer amplifier. By substituting into the gain formula the 1 kHz bandwidth R_5 ($10 + 60 = 70$ ohms), a new gain of 4.0 (12 dB) is derived.

First XTAL Pole (D)

Crystal filtering is used for bandwidths of 1 kHz, 3 kHz, 10 kHz, and 30 kHz. Individual poles have a bandwidth about 2.3 times the selected bandwidth, and each filter board assembly (two poles combined) has a bandwidth of about 1.5 times the selected bandwidth. For example, when the 1 kHz bandwidth is selected, each pole has a 3 dB bandwidth of about 2.3 kHz, each assembly a bandwidth of 1.5 kHz. The signal from the input

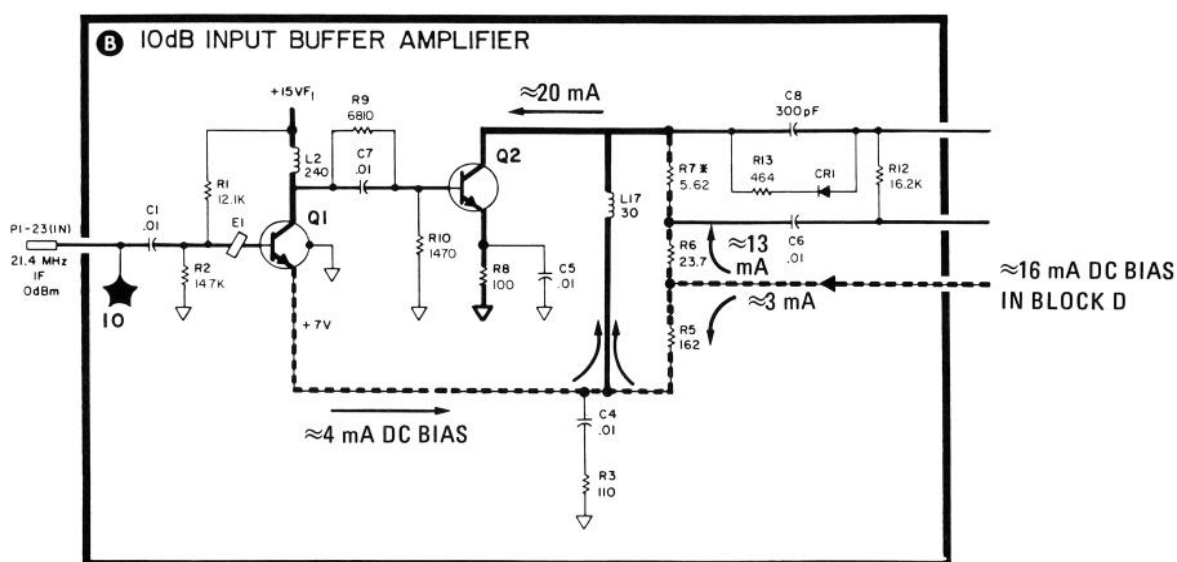

FIGURE 8-35. DC BIAS PATH DURING CRYSTAL POLE OPERATION

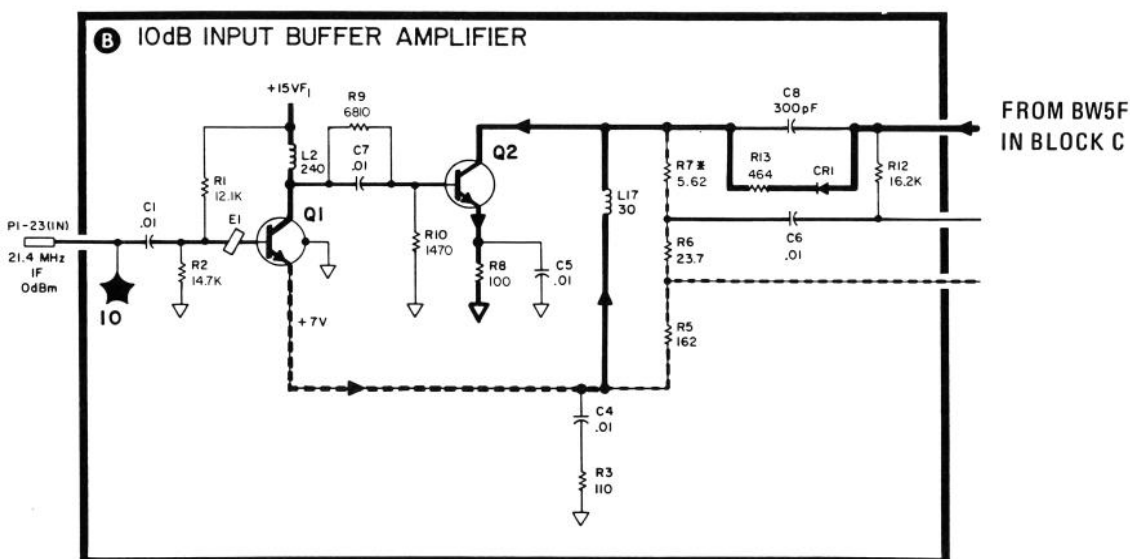
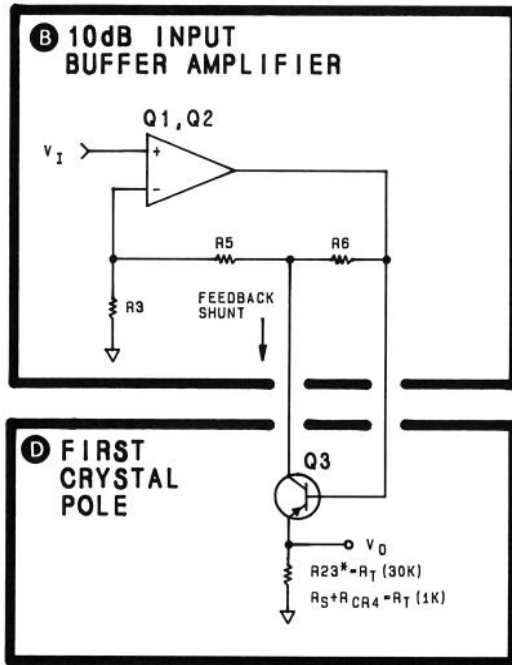

FIGURE 8-36. DC BIAS PATH DURING LC POLE OPERATION



$$GAIN = \frac{1 + \frac{R5+R6}{R3}}{1 - \frac{R6}{Rt}}$$

FOR 30K BW:
When: $Rt = 8250 \Omega$

$$\text{Then: } GAIN = \frac{1 + \frac{185.7}{110}}{1 - \frac{23.7}{82.50}} = 2.69 \text{ GAIN } 2.70 \approx 8.6dB$$

FOR 1K BW:
When: $Rt = 70 \Omega$

$$\text{Then: } GAIN = \frac{2.69}{.66} \approx 4.0 \approx 12dB$$

FIGURE 8-37. 10 dB INPUT BUFFER AMPLIFIER DURING CRYSTAL FILTER OPERATION

buffer amplifier is routed to Q3 and to compensation amplifier Q4. (The action of Q3 is discussed in the 10 dB Input Buffer Amplifier description.) From Q3, the signal is applied to the crystal (Y1) where it is filtered before going to the unity gain buffer amplifier.

The crystal functions as a series-resonant filter tuned to 21.4 MHz. An equivalent circuit is shown in Figure 8-38. Parallel capacitance C_0 is the result of terminal and case capacitances in the crystal; R_s is the effective resistance at resonance (about 10 ohms). Both C_0 and R_s are detrimental to the pole's performance, so compensation is used to nullify their effects. Because they are cancelled, C_0 and R_s are not shown in the simplified crystal pole schematic.

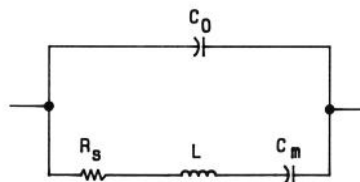

FIGURE 8-38. CRYSTAL MODEL

Pin diode CR4 (see Figure 8-39) controls the filter's bandwidth by functioning as a variable resistance at 21.4 MHz. The voltage applied to BW6F controls the current through CR4 and its resistance. An increase in current decreases the resistance and narrows the bandshape.

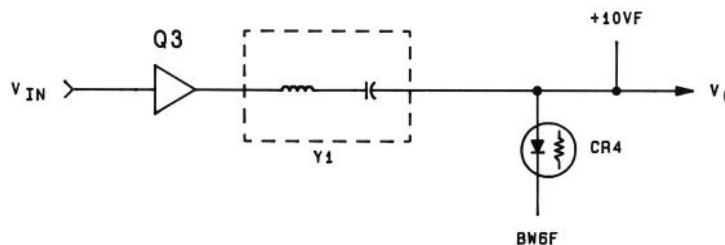

FIGURE 8-39. FIRST CRYSTAL POLE, SIMPLIFIED SCHEMATIC

The crystal presents a low impedance (R_s) to the signal at resonance; hence, signal voltage is developed across CR4. As the signal frequency varies from the center frequency (21.4 MHz), the impedance of the crystal increases, making it part of a voltage divider with CR4 and causing more signal voltage to be developed across the crystal. The frequencies where crystal impedance and PIN diode resistance become equal are the 3 dB points of the bandpass. Varying the PIN diode resistance, therefore, varies the bandwidth.

The case capacitance of the crystal (C_o) would cause a second resonant point, or dip, in the bandpass if compensation were not used to nullify its effects. Compensation is provided by Q4 as a current equal to and opposite in phase with the current flowing through C_o , as shown in Figure 8-40. Capacitor C15 (SYM) adjusts the phase of the compensating current.

The input capacitance of the unity gain buffer, the trace capacitances, and the capacitance of the PIN diode add, causing the center frequency of the filter to be altered. Compensation is used to eliminate this effect. These capacitances are tuned out by including them in a parallel resonant circuit (at 21.4 MHz) formed with L7 and fine tuned by C25 (CTR). Adjusting C25 tunes the circuit to present a high impedance at resonance.

When LC filtering is selected, BW5F forward biases CR2, effectively grounding the emitter of Q3. During crystal filtering, CR2 is reversed biased.

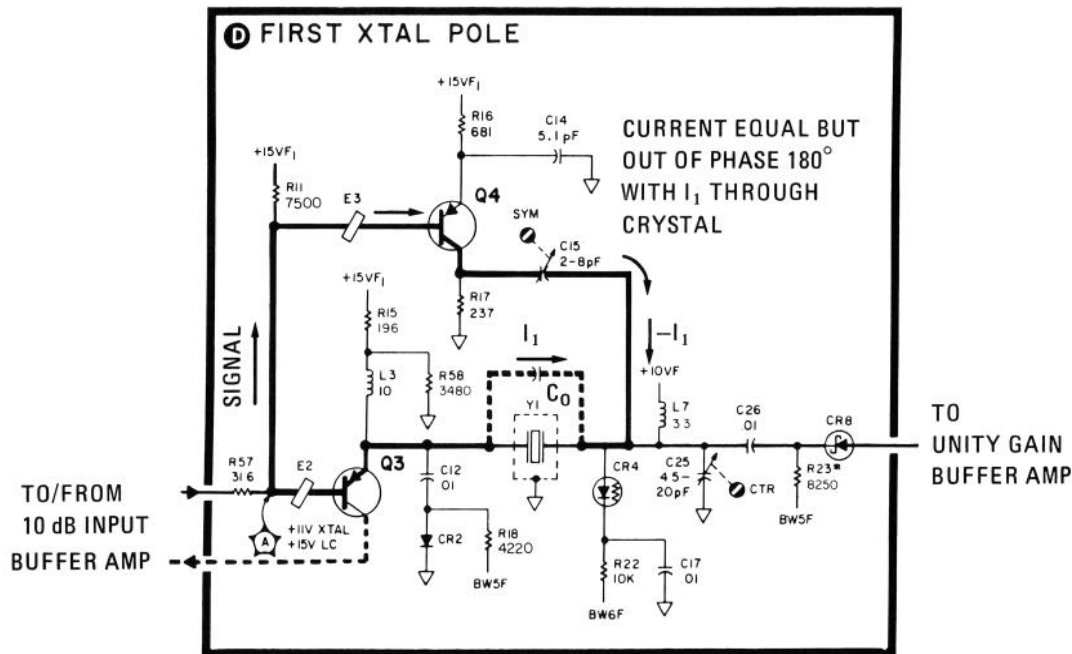

FIGURE 8-40. COMPENSATION AMPLIFIER

First LC Pole (C)

LC filtering is used for bandwidths of 100 kHz, 300 kHz, 1 MHz, and 3 MHz. The relationship of the individual pole's bandwidth to the selected bandwidth is the same as the crystal poles' (2.3 times per pole and 1.5 times per assembly). The LC filter pole comprises a metallized inductor (L6) in parallel with four capacitors: the series combination of C16* and C20*, C21 (temperature compensation), and C23 (center adjust). This resonant circuit is driven through CR3, which functions as a variable resistor. Bandwidth control line BW7F establishes the current through CR3 and thereby controls the pole's bandwidth. Feedback from the unity gain buffer replenishes losses in the resonant circuit.

A simplified model of the LC Pole is shown in Figure 8-41. At resonance, a voltage divider is formed between CR3 and the resonant circuit. The 3 dB points of the bandpass occur when the PIN resistance and the impedance of the resonant circuit are equal. Varying the PIN resistance varies the filter's 3 dB points. The higher the PIN resistance, the narrower the bandwidth. When the 100 kHz bandwidth is selected, CR3 is reverse biased and R19* sets the bandwidth; if one of the other bandwidths is selected, the parallel combination of R19* and CR3 is utilized. The intrinsic capacitance of PIN diode CR3 affects the bandpass, if it is not compensated for. Adjustable capacitance C73 (LC DIP) and L5 are in parallel with the PIN capacitance and allow it to be tuned out of the circuit.

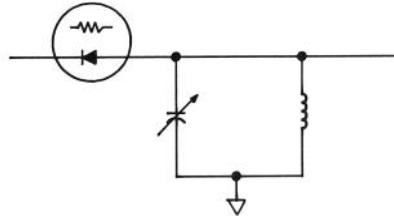

FIGURE 8-41. LC POLE MODEL

A simplified schematic of the first LC pole is shown in Figure 8-42. The fundamental frequency-determining components are L6 and the center-tapped capacitance C16* and C20*. Positive feedback is applied to the center-tap at 21.4 MHz to compensate for losses in the tank circuit. The application of feedback makes it important that C16* and C20* be the same value for proper pole operation. The level of the feedback is controlled by CR5, acting as a variable resistance. LC feedback control R26 establishes the current through CR5 and its resistance.

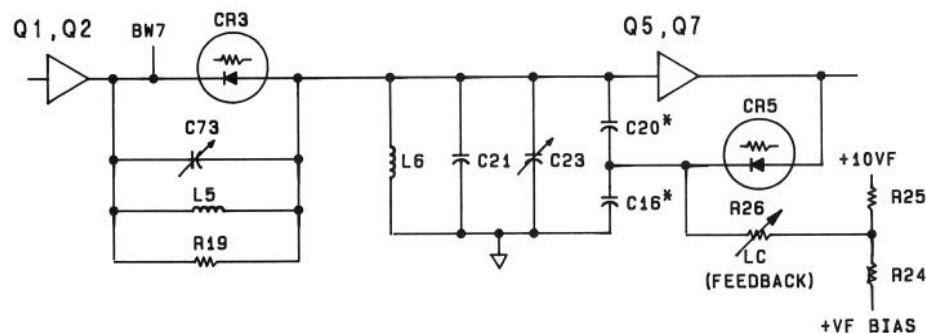

FIGURE 8-42. FIRST LC POLE, SIMPLIFIED SCHEMATIC

When an LC filtered bandwidth is selected, BW5F is at +15V; BW7F is at a voltage greater than or equal to +6.8V and supplies bandwidth-determining bias current to CR3. Supply line +VF BIAS is always at +6.8V. Control line BW5F reverse biases CR8 (block **(B)**), disabling the crystal pole, and forward biases CR1 (block **(B)**) opening the dc bias path to Q2 (see Figure 8-36). During LC operation, CR6 is reverse biased, keeping C28 out of the circuit. When a crystal filtered bandwidth is selected, BW5F forward biases CR6 and allows C28 to ground the signal path.

Unity Gain Buffer Amplifier (E)

Operation of the Unity Gain Buffer Amplifier is similar to the 10 dB Input Buffer Amplifier, except that it has an FET input (Q5) and unity gain. The input signal path is activated by the BW5F line, which switches on CR9 (during LC mode) or CR8 (during crystal mode).

When the crystal mode is selected, the current through the input FET (Q5) is determined by Q6 and constant current sink Q7 (which sinks about 4 mA). During LC mode, current is supplied through R37 and CR10 from BW5F. The input FET current is a good indication of the stage's operation and can be monitored by measuring the gate-to-source voltage. This voltage should fall between +0.2V and +1.5V (an increase in current decreases the voltage).

Capacitor C68 and L19 form a feedback circuit that tunes Q7 to 21.4 MHz. Trimmer Resistor R31 (XTL FEEDBACK) adjusts the feedback and controls the stage gain, as did R5 and R6 in block (B).

Second XTAL Pole (G)

The operation of the Second Xtal Pole is identical with the First Xtal Pole.

Second LC Pole (F)

Operation of the Second LC Pole is the same as the First LC Pole, except that R56* performs the same function as PIN diode CR5.

Output Buffer Amplifier (H)

The Output Buffer Amplifier is a complementary pair of transistors in which Q9 acts as a source follower with its output current boosted by Q10. The current through input FET Q9 is established by R53:

$$I_{\text{FET}} = V_{\text{be}(Q10)}/R53$$

Which becomes: $I_{\text{FET}} = .7/196$, or about 3 mA.

The total current through Q9 and Q10 is set by R54. The input signal path is selected by either CR15 (during crystal mode) or CR16 (during LC mode).

BANDWIDTH FILTERS ASSEMBLIES No. 1 and No. 2, A11 and A13, TROUBLESHOOTING

Observe front panel switch positions in relation to the problem to isolate the area of the failure.

Check for leaky diodes and capacitors. Loading of the signal path can alter either a pole's gain or bandpass shape or both.

Isolate crystal poles from LC poles to prevent interaction of failure symptoms. Isolation of the crystal poles from the circuit is best achieved by removing CR8 and CR15 (blocks **(D)** and **(G)**). Isolation of the LC poles is best achieved by removing CR9 and CR16 (blocks **(C)** and **(F)**).

TABLE 8-11. A11 BANDWIDTH FILTER NO. 1 ASSEMBLY, REPLACEABLE PARTS (1 OF 3)

Reference Designation	HP Part Number	C D	Qty	Description	Mfr Code	Mfr Part Number
A11	08559-60058	0	1	BANDWIDTH FILTER NO. 1 ASSEMBLY	28480	08559-60058
A11C1	0160-2055	9	38	CAPACITOR-FXD .01UF +80-20% 100VDC CER	28480	0160-2055
A11C2	0160-0127	2	1	CAPACITOR-FXD 1UF +-20% 25VDC CER	28480	0160-0127
A11C3				NOT ASSIGNED		
A11C4	0160-2055	9		CAPACITOR-FXD .01UF +80-20% 100VDC CER	28480	0160-2055
A11C5	0160-2055	9		CAPACITOR-FXD .01UF +80-20% 100VDC CER	28480	0160-2055
A11C6	0160-2055	9		CAPACITOR-FXD .01UF +80-20% 100VDC CER	28480	0160-2055
A11C7	0160-2055	9		CAPACITOR-FXD .01UF +80-20% 100VDC CER	28480	0160-2055
A11C8	0160-2207	3	2	CAPACITOR-FXD 300PF +-5% 300VDC MICA	28480	0160-2207
A11C9	0160-2055	9		CAPACITOR-FXD .01UF +80-20% 100VDC CER	28480	0160-2055
A11C10	0160-2055	9		CAPACITOR-FXD .01UF +80-20% 100VDC CER	28480	0160-2055
A11C11	0160-2055	9		CAPACITOR-FXD .01UF +80-20% 100VDC CER	28480	0160-2055
A11C12	0160-2055	9		CAPACITOR-FXD .01UF +80-20% 100VDC CER	28480	0160-2055
A11C13	0160-3456	6	3	CAPACITOR-FXD 1000PF +-10% 1KVDC CER	28480	0160-3456
A11C14	0160-2249	3	2	CAPACITOR-FXD 4.7PF +- .25PF 500VDC CER	28480	0160-2249
A11C15	0121-0059	7	2	CAPACITOR-V TRMR-CER 2-8PF 350V PC-MTG	52763	304324 2/8PF NPO
A11C16*	0160-0134	1	4	CAPACITOR-FXD 220PF +-5% 300VDC MICA	28480	0160-0134
A11C17	0160-2055	9		CAPACITOR-FXD .01UF +80-20% 100VDC CER	28480	0160-2055
A11C18	0160-2055	9		CAPACITOR-FXD .01UF +80-20% 100VDC CER	28480	0160-2055
A11C19	0160-2055	9		CAPACITOR-FXD .01UF +80-20% 100VDC CER	28480	0160-2055
A11C20*	0160-0134	1		CAPACITOR-FXD 220PF +-5% 300VDC MICA	28480	0160-0134
A11C21	0160-0437	7	2	CAPACITOR-FXD 12PF +-5% 500VDC CER	28480	0160-0437
A11C22	0160-4084	8	3	CAPACITOR-FXD .1UF +-20% 50VDC CER	28480	0160-4084
A11C23	0121-0036	0	2	CAPACITOR-V TRMR-CER 5.5-18PF 350V	52763	304324 5.5/18PF NPO
A11C24	0160-2055	9		CAPACITOR-FXD .01UF +80-20% 100VDC CER	28480	0160-2055
A11C25	0121-0446	6	2	CAPACITOR-V TRMR-CER 4.5-20PF 160V	28480	0121-0446
A11C26	0160-2055	9		CAPACITOR-FXD .01UF +80-20% 100VDC CER	28480	0160-2055
A11C27	0160-2055	9		CAPACITOR-FXD .01UF +80-20% 100VDC CER	28480	0160-2055
A11C28	0160-2055	9		CAPACITOR-FXD .01UF +80-20% 100VDC CER	28480	0160-2055
A11C29	0160-3456	6		CAPACITOR-FXD 1000PF +-10% 1KVDC CER	28480	0160-3456
A11C30	0160-2055	9		CAPACITOR-FXD .01UF +80-20% 100VDC CER	28480	0160-2055
A11C31	0160-4290	6	1	CAPACITOR-FXD 4700PF +-20% 250VDC CER	56289	C067F251H472MS22-CDH
A11C32	0160-4084	8		CAPACITOR-FXD .1UF +-20% 50VDC CER	28480	0160-4084
A11C33	0160-2207	3		CAPACITOR-FXD 300PF +-5% 300VDC MICA	28480	0160-2207
A11C34	0160-2055	9		CAPACITOR-FXD .01UF +80-20% 100VDC CER	28480	0160-2055
A11C35	0160-2055	9		CAPACITOR-FXD .01UF +80-20% 100VDC CER	28480	0160-2055
A11C36	0160-2055	9		CAPACITOR-FXD .01UF +80-20% 100VDC CER	28480	0160-2055
A11C37	0160-2249	3		CAPACITOR-FXD 4.7PF +- .25PF 500VDC CER	28480	0160-2249
A11C38	0121-0059	7		CAPACITOR-V TRMR-CER 2-8PF 350V PC-MTG	52763	304324 2/8PF NPO
A11C39				NOT ASSIGNED		
A11C40	0160-2055	9		CAPACITOR-FXD .01UF +80-20% 100VDC CER	28480	0160-2055
A11C41	0160-3456	6		CAPACITOR-FXD 1000PF +-10% 1KVDC CER	28480	0160-3456
A11C42	0160-2055	9		CAPACITOR-FXD .01UF +80-20% 100VDC CER	28480	0160-2055
A11C43*	0160-0134	1		CAPACITOR-FXD 220PF +-5% 300VDC MICA	28480	0160-0134
A11C44	0160-0437	7		CAPACITOR-FXD 12PF +-5% 500VDC CER	28480	0160-0437
A11C45	0121-0036	0		CAPACITOR-V TRMR-CER 5.5-18PF 350V	52763	304324 5.5/18PF NPO
A11C46	0160-4084	8		CAPACITOR-FXD .1UF +-20% 50VDC CER	28480	0160-4084
A11C47	0160-2055	9		CAPACITOR-FXD .01UF +80-20% 100VDC CER	28480	0160-2055
A11C48	0160-2055	9		CAPACITOR-FXD .01UF +80-20% 100VDC CER	28480	0160-2055
A11C49	0160-2055	9		CAPACITOR-FXD .01UF +80-20% 100VDC CER	28480	0160-2055
A11C50	0160-2055	9		CAPACITOR-FXD .01UF +80-20% 100VDC CER	28480	0160-2055
A11C51	0160-2055	9		CAPACITOR-FXD .01UF +80-20% 100VDC CER	28480	0160-2055
A11C52	0160-2055	9		CAPACITOR-FXD .01UF +80-20% 100VDC CER	28480	0160-2055
A11C53	0160-2055	9		CAPACITOR-FXD .01UF +80-20% 100VDC CER	28480	0160-2055
A11C54	0121-0446	6		CAPACITOR-V TRMR-CER 4.5-20PF 160V	28480	0121-0446
A11C55	0160-2055	9		CAPACITOR-FXD .01UF +80-20% 100VDC CER	28480	0160-2055
A11C56-				NOT ASSIGNED		
A11C59				NOT ASSIGNED		
A11C60	0160-2055	9		CAPACITOR-FXD .01UF +80-20% 100VDC CER	28480	0160-2055
A11C61	0160-2055	9		CAPACITOR-FXD .01UF +80-20% 100VDC CER	28480	0160-2055
A11C62	0160-2055	9		CAPACITOR-FXD .01UF +80-20% 100VDC CER	28480	0160-2055
A11C63	0160-2055	9		CAPACITOR-FXD .01UF +80-20% 100VDC CER	28480	0160-2055
A11C64*	0160-0134	1		CAPACITOR-FXD 220PF +-5% 300VDC MICA	28480	0160-0134
A11C65	0160-2055	9		CAPACITOR-FXD .01UF +80-20% 100VDC CER	28480	0160-2055
A11C66	0160-2055	9		CAPACITOR-FXD .01UF +80-20% 100VDC CER	28480	0160-2055
A11C67	0160-2055	9		CAPACITOR-FXD .01UF +80-20% 100VDC CER	28480	0160-2055
A11C68	0160-2258	4	1	CAPACITOR-FXD 11PF +-5% 500VDC CER 0+-30	28480	0160-2258
A11C69	0160-2055	9		CAPACITOR-FXD .01UF +80-20% 100VDC CER	28480	0160-2055
A11C70-				NOT ASSIGNED		
A11C72				NOT ASSIGNED		
A11C73	0121-0452	4	2	CAPACITOR-V TRMR-AIR 1.3-5.4PF 175V	74970	187-0103-028

*Indicates factory selected value

TABLE 8-11. A11 BANDWIDTH FILTER NO. 1 ASSEMBLY, REPLACEABLE PARTS (2 OF 3)

Reference Designation	HP Part Number	C D	Qty	Description	Mfr Code	Mfr Part Number
A11C74	0121-0452	4		CAPACITOR-V TRMR-AIR 1.3-5.4PF 175V	74970	187-0103-028
A11CR1	1901-0047	8	6	DIODE-SWITCHING 20V 75MA 10NS	28480	1901-0047
A11CR2	1901-0047	8		DIODE-SWITCHING 20V 75MA 10NS	28480	1901-0047
A11CR3	1901-1070	9	5	DIODE-PIN 110V	28480	1901-1070
A11CR4	1901-1070	9		DIODE-PIN 110V	28480	1901-1070
A11CR5	1901-1070	9		DIODE-PIN 110V	28480	1901-1070
A11CR6	1901-0535	9	5	DIODE-SM SIG SCHOTTKY	28480	1901-0535
A11CR7		9		NOT ASSIGNED		
A11CR8	1901-0535	9		DIODE-SM SIG SCHOTTKY	28480	1901-0535
A11CR9	1901-0047	8		DIODE-SWITCHING 20V 75MA 10NS	28480	1901-0047
A11CR10	1901-0047	8		DIODE-SWITCHING 20V 75MA 10NS	28480	1901-0047
A11CR11	1901-1070	9		DIODE-PIN 110V	28480	1901-1070
A11CR12	1901-1070	9		DIODE-PIN 110V	28480	1901-1070
A11CR13	1901-0047	8		DIODE-SWITCHING 20V 75MA 10NS	28480	1901-0047
A11CR14	1901-0535	9		DIODE-SM SIG SCHOTTKY	28480	1901-0535
A11CR15	1901-0535	9		DIODE-SM SIG SCHOTTKY	28480	1901-0535
A11CR16	1901-0047	8		DIODE-SWITCHING 20V 75MA 10NS	28480	1901-0047
A11CR17	1901-0535	9		DIODE-SM SIG SCHOTTKY	28480	1901-0535
A11E1	9170-0029	3	8	CORE-SHIELDING BEAD	28480	9170-0029
A11E2	9170-0029	3		CORE-SHIELDING BEAD	28480	9170-0029
A11E3	9170-0029	3		CORE-SHIELDING BEAD	28480	9170-0029
A11E4	9170-0029	3		CORE-SHIELDING BEAD	28480	9170-0029
A11E5	9170-0029	3		CORE-SHIELDING BEAD	28480	9170-0029
A11E6	9170-0029	3		CORE-SHIELDING BEAD	28480	9170-0029
A11E7	9170-0029	3		CORE-SHIELDING BEAD	28480	9170-0029
A11E8	9170-0029	3		CORE-SHIELDING BEAD	28480	9170-0029
A11L1	9140-0112	2	1	INDUCTOR RF-CH-MLD 4.7UH 10%	28480	9140-0112
A11L2	9100-1641	0	1	INDUCTOR RF-CH-MLD 240UH 5% .166DX.385LG	28480	9100-1641
A11L3	9140-0114	4	2	INDUCTOR RF-CH-MLD 10UH 10% .166DX.385LG	28480	9140-0114
A11L4	9100-1624	9	3	INDUCTOR RF-CH-MLD 30UH 5% .166DX.385LG	28480	9100-1624
A11L5	9140-0179	1	2	INDUCTOR RF-CH-MLD 22UH 10% .166DX.385LG	28480	9140-0179
A11L6	9100-2813	0	2	INDUCTOR 400NH 10% .312DX1.016LG Q=150	28480	9100-2813
A11L7	9140-0399	7	2	INDUCTOR RF-CH-MLD 2.2UH 5% .166DX.385LG	28480	9140-0399
A11L8	9140-0178	0	1	INDUCTOR RF-CH-MLD 12UH 10% .166DX.385LG	28480	9140-0178
A11L9	9100-1619	2	2	INDUCTOR RF-CH-MLD 6.8UH 10%	28480	9100-1619
A11L10	9140-0114	4		INDUCTOR RF-CH-MLD 10UH 10% .166DX.385LG	28480	9140-0114
A11L11	9100-1624	9		INDUCTOR RF-CH-MLD 30UH 5% .166DX.385LG	28480	9100-1624
A11L12	9140-0179	1		INDUCTOR RF-CH-MLD 22UH 10% .166DX.385LG	28480	9140-0179
A11L13	9140-0399	7		INDUCTOR RF-CH-MLD 2.2UH 5% .166DX.385LG	28480	9140-0399
A11L14	9100-1620	5	1	INDUCTOR RF-CH-MLD 15UH 10% .166DX.385LG	28480	9100-1620
A11L15	9100-2813	0		INDUCTOR 400NH 10% .312DX1.016LG Q=150	28480	9100-2813
A11L16	9140-0144	0	2	INDUCTOR RF-CH-MLD 4.7UH 10% .105DX.26LG	28480	9140-0144
A11L17	9100-1624	9		INDUCTOR RF-CH-MLD 30UH 5% .166DX.385LG	28480	9100-1624
A11L18	9100-1619	2		INDUCTOR RF-CH-MLD 6.8UH 10%	28480	9100-1619
A11L19	9140-0144	0		INDUCTOR RF-CH-MLD 4.7UH 10% .105DX.26LG	28480	9140-0144
A11Q1	1854-0345	8	1	TRANSISTOR NPN 2N5179 SI TO-72 PD=200MW	04713	2N5179
A11Q2	1854-0404	0	2	TRANSISTOR NPN SI TO-18 PD=360MW	28480	1854-0404
A11Q3	1853-0007	7	5	TRANSISTOR PNP 2N3251 SI TO-18 PD=360MW	04713	2N3251
A11Q4	1853-0007	7		TRANSISTOR PNP 2N3251 SI TO-18 PD=360MW	04713	2N3251
A11Q5	1855-0267	5	2	TRANSISTOR J-FET N-CHAN D-MODE TO-92 SI	28480	1855-0267
A11Q6	1853-0007	7		TRANSISTOR PNP 2N3251 SI TO-18 PD=360MW	04713	2N3251
A11Q7	1854-0404	0		TRANSISTOR NPN SI TO-18 PD=360MW	28480	1854-0404
A11Q8	1853-0007	7		TRANSISTOR PNP 2N3251 SI TO-18 PD=360MW	04713	2N3251
A11Q9	1855-0267	5		TRANSISTOR J-FET N-CHAN D-MODE TO-92 SI	28480	1855-0267
A11Q10	1853-0007	7		TRANSISTOR PNP 2N3251 SI TO-18 PD=360MW	04713	2N3251
A11R1	0757-0444	1		RESISTOR 12.1K 1% .125W F TC=0+-100	24546	C4-1/8-T0-1212-F
A11R2	0698-3156	2	1	RESISTOR 14.7K 1% .125W F TC=0+-100	24546	C4-1/8-T0-1472-F
A11R3	0757-0402	1	2	RESISTOR 110 1% .125W F TC=0+-100	24546	C4-1/8-T0-111-F
A11R4	0757-0442	9	8	RESISTOR 10K 1% .125W F TC=0+-100	24546	C4-1/8-T0-1002-F
A11R5	0757-0405	4	1	RESISTOR 162 1% .125W F TC=0+-100	24546	C4-1/8-T0-162R-F
A11R6	0698-3431	6	1	RESISTOR 23.7 1% .125W F TC=0+-100	03888	PKE55-1/8-T0-23R7-F
A11R7*	0698-8821	8	1	RESISTOR 5.62 1% .125W F TC=0+-100	28480	0698-8821
A11R8	0757-0401	0	3	RESISTOR 100 1% .125W F TC=0+-100	24546	C4-1/8-T0-101-F
A11R9	0757-0439	4	1	RESISTOR 6.81K 1% .125W F TC=0+-100	24546	C4-1/8-T0-6811-F
A11R10	0757-1094	9	1	RESISTOR 1.47K 1% .125W F TC=0+-100	24546	C4-1/8-T0-1471-F
A11R11	0757-0440	7	1	RESISTOR 7.5K 1% .125W F TC=0+-100	24546	C4-1/8-T0-7501-F
A11R12	0757-0447	4	1	RESISTOR 16.2K 1% .125W F TC=0+-100	24546	C4-1/8-T0-1622-F
A11R13	0698-0082	7	1	RESISTOR 464 1% .125W F TC=0+-100	24546	C4-1/8-T0-4640-F
A11R14	0757-0346	2	4	RESISTOR 10 1% .125W F TC=0+-100	24546	C4-1/8-T0-10R0-F
A11R15	0698-3440	7	2	RESISTOR 196 1% .125W F TC=0+-100	24546	C4-1/8-T0-196R-F
A11R16	0757-0419	0	2	RESISTOR 681 1% .125W F TC=0+-100	24546	C4-1/8-T0-681R-F
A11R17	0698-3442	9	2	RESISTOR 237 1% .125W F TC=0+-100	24546	C4-1/8-T0-237R-F
A11R18	0698-3154	0	2	RESISTOR 4.22K 1% .125W F TC=0+-100	24546	C4-1/8-T0-4221-F
A11R19*	0698-3155	1	2	RESISTOR 4.64K 1% .125W F TC=0+-100	24546	C4-1/8-T0-4641-F
A11R20	0757-0442	9		RESISTOR 10K 1% .125W F TC=0+-100	24546	C4-1/8-T0-1002-F

*Indicates factory selected value

TABLE 8-11. A11 BANDWIDTH FILTER NO. 1 ASSEMBLY, REPLACEABLE PARTS (3 OF 3)

Reference Designation	HP Part Number	C D	Qty	Description	Mfr Code	Mfr Part Number
A11R21	0757-0442	9		RESISTOR 10K 1% .125W F TC=0+-100	24546	C4-1/8-T0-1002-F
A11R22	0757-0442	9		RESISTOR 10K 1% .125W F TC=0+-100	24546	C4-1/8-T0-1002-F
A11R23*	0757-0288	1	2	RESISTOR 9.09K 1% .125W F TC=0+-100	19731	MF4C1/8-T0-9091-F
A11R24	0757-0465	6	2	RESISTOR 100K 1% .125W F TC=0+-100	24546	C4-1/8-T0-1003-F
A11R25	0757-0465	6		RESISTOR 100K 1% .125W F TC=0+-100	24546	C4-1/8-T0-1003-F
A11R26	2100-3163	8	1	RESISTOR-TRMR 1M 26% C SIDE-ADJ 17-TRN	02111	43P105
A11R27	0757-0444	1		RESISTOR 12.1K 1% .125W F TC=0+-100	24546	C4-1/8-T0-1212-F
A11R28	0757-0443	0	2	RESISTOR 11K 1% .125W F TC=0+-100	24546	C4-1/8-T0-1102-F
A11R29	0698-0083	8	2	RESISTOR 1.96K 1% .125W F TC=0+-100	24546	C4-1/8-T0-1961-F
A11R30	0757-0402	1		RESISTOR 110 1% .125W F TC=0+-100	24546	C4-1/8-T0-111-F
A11R31	2100-3052	4	1	RESISTOR-TRMR 50 10% C SIDE-ADJ 17-TRN	02111	43P500
A11R32*	0698-3454	3		RESISTOR 215K 1% .125W F TC=0+-100	24546	C4-1/8-T0-2153-F
A11R33	0757-0442	9		RESISTOR 10K 1% .125W F TC=0+-100	24546	C4-1/8-T0-1002-F
A11R34	0757-0199	3	1	RESISTOR 21.5K 1% .125W F TC=0+-100	24546	C4-1/8-T0-2152-F
A11R35	0757-0268	1		RESISTOR 9.09K 1% .125W F TC=0+-100	19731	MF4C1/8-T0-9091-F
A11R36	0698-0083	8		RESISTOR 1.96K 1% .125W F TC=0+-100	24546	C4-1/8-T0-1961-F
A11R37	0757-0416	7	2	RESISTOR 511 1% .125W F TC=0+-100	24546	C4-1/8-T0-511R-F
A11R38	0698-3441	8	1	RESISTOR 215 1% .125W F TC=0+-100	24546	C4-1/8-T0-215R-F
A11R39	0757-0419	0		RESISTOR 681 1% .125W F TC=0+-100	24546	C4-1/8-T0-681R-F
A11R40	0698-3442	9		RESISTOR 237 1% .125W F TC=0+-100	24546	C4-1/8-T0-237R-F
A11R41	0698-3154	0		RESISTOR 4.22K 1% .125W F TC=0+-100	24546	C4-1/8-T0-4221-F
A11R42	0757-0442	9		RESISTOR 10K 1% .125W F TC=0+-100	24546	C4-1/8-T0-1002-F
A11R43*	0698-3155	1		RESISTOR 4.64K 1% .125W F TC=0+-100	24546	C4-1/8-T0-4641-F
A11R44	0757-0442	9		RESISTOR 10K 1% .125W F TC=0+-100	24546	C4-1/8-T0-1002-F
A11R45	0757-0401	0		RESISTOR 100 1% .125W F TC=0+-100	24546	C4-1/8-T0-101-F
A11R46	0757-0401	0		RESISTOR 100 1% .125W F TC=0+-100	24546	C4-1/8-T0-101-F
A11R47	0757-0346	2		RESISTOR 10 1% .125W F TC=0+-100	24546	C4-1/8-T0-10R0-F
A11R48*	0757-0444	1	4	RESISTOR 12.1K 1% .125W F TC=0+-100	24546	C4-1/8-T0-1212-F
A11R49	0757-0444	1		RESISTOR 12.1K 1% .125W F TC=0+-100	24546	C4-1/8-T0-1212-F
A11R50	0757-0346	2		RESISTOR 10 1% .125W F TC=0+-100	24546	C4-1/8-T0-10R0-F
A11R51	0757-0346	2		RESISTOR 10 1% .125W F TC=0+-100	24546	C4-1/8-T0-10R0-F
A11R52	0757-0443	0		RESISTOR 11K 1% .125W F TC=0+-100	24546	C4-1/8-T0-1102-F
A11R53	0698-3440	7		RESISTOR 196 1% .125W F TC=0+-100	24546	C4-1/8-T0-196R-F
A11R54	0757-0416	7		RESISTOR 511 1% .125W F TC=0+-100	24546	C4-1/8-T0-511R-F
A11R55	0757-0442	9		RESISTOR 10K 1% .125W F TC=0+-100	24546	C4-1/8-T0-1002-F
A11R56*	0757-0274	5	1	RESISTOR 1.21K 1% .125W F TC=0+-100	24546	C4-1/8-T0-1211-F
A11R57	0757-0180	2	2	RESISTOR 31.6 1% .125W F TC=0+-100	28480	0757-0180
A11R58	0698-3152	8	1	RESISTOR 3.48K 1% .125W F TC=0+-100	24546	C4-1/8-T0-3481-F
A11R59	0757-0180	2		RESISTOR 31.6 1% .125W F TC=0+-100	28480	0757-0180
A11R60	0698-3153	9	1	RESISTOR 3.03K 1% .125W F TC=0+-100	24546	C4-1/8-T0-3031-F
A11TP1	0360-1788	7	4	CONNECTOR-SGL CONT PIN .045-IN-BSC-SZ SQ	28480	0360-1788
A11TP2	0360-1788	7		CONNECTOR-SGL CONT PIN .045-IN-BSC-SZ SQ	28480	0360-1788
A11TP3	1251-0600	0	2	CONNECTOR-SGL CONT PIN 1.14-MM-BSC-SZ SQ	28480	1251-0600
A11TP4-				NOT ASSIGNED		
A11TP5						
A11TP6	1251-0600	0		CONNECTOR-SGL CONT PIN 1.14-MM-BSC-SZ SQ	28480	1251-0600
A11VR1	1902-0048	1	1	DIODEC-ZNR 6.81V 5% DO-35 PD=.4W	28480	1902-0048
A11Y1	0410-0776	8	2	CRYSTAL QUARTZ 21.4 MHZ HC-25/U-HLDR	28480	0410-0776
A11Y2	0410-0776	8		SET OF 4 INCLUDES A11Y1,Y2 AND A13Y1,Y2	28480	0410-0776
				CRYSTAL QUARTZ 21.4 MHZ HC-25/U-HLDR		
				SET OF 4 INCLUDES A11Y1,Y2 AND A13Y1,Y2		
				MISCELLANEOUS		
	0403-0026	6	1	PLUG-HOLE BDR-HD FOR .187-D-HOLE NYL	02769	207-120241-03-0101
	08559-00025	5	1	BAFFLE INDUCTOR	28480	08559-00025

*Indicates factory selected value

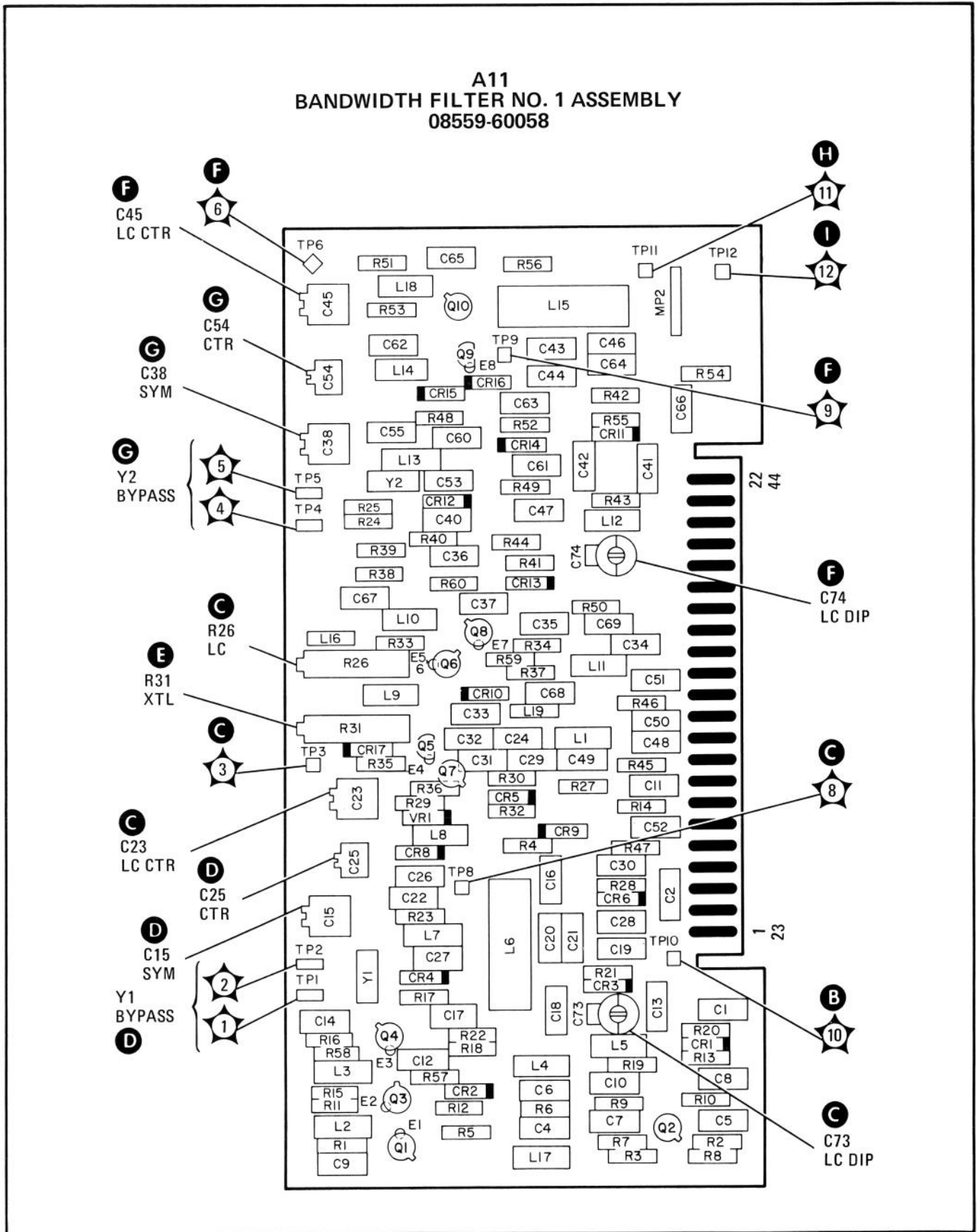

FIGURE 8-43. A11 BANDWIDTH FILTER NO. 1, COMPONENT LOCATIONS

A12 STEP GAIN, CIRCUIT DESCRIPTION

General Description

The Step Gain Assembly contains three amplifier stages to provide a 0 to 50 dB amplification of the 21.4 MHz third IF signal. The amplifier stages are selected by front panel REF LEVEL dBm switch A2S1. At the output of the final amplifier is a two-section bandpass filter. In conjunction with the front panel REF LEVEL FINE control, the step gain assembly also contains the circuitry for the 0 to 12 dB fine control for the reference level. A TEST/NORM switch is available; in TEST position, tests are made at a low gain level.

0 – 12 dB Control (A)

A minimum current flow through PIN diode A12CR3 (maximum allowable diode resistance) is established by the – 12 dB potentiometer, A12R6, so the diode is never completely cutoff. Adjustment of A12R6 sets the 0.3 dB point and is adjusted with the REF LEVEL FINE control fully clockwise (– 12 position).

The maximum current flow through the PIN diode is set by the 0 dB potentiometer, A12R5. A12R5 is adjusted to the 12.3 dB attenuation point with the REF LEVEL FINE control fully counterclockwise (0 position).

Transistors A12Q8 and A12Q9 are identical current sources. The maximum current is set by 0 dB adjustment A12R5 in the common base circuit. Diode A12CR1 provides temperature compensation for the transistors.

A12Q8 provides current for a bias voltage applied to the anode of the PIN diode. The voltage source consists of A12R6, A12R17, and A12CR2. Diode A12CR2 provides temperature compensation for the PIN diode. Inductance A12L5 isolates the current source from the RF signal.

A12Q9 provides current for a variable voltage source at the cathode of PIN diode A12CR3. A resistance is formed by REF LEVEL FINE control R4 (shown on A2 schematic) and fixed resistor A12R9. The fixed 316K ohm resistor is used to shape the value of potentiometer R4 to match the PIN diode resistance changes. The REF LEVEL FINE control varies the voltage at the cathode of PIN diode A12CR3 and thus varies diode current flow. Regulating the current flow through the PIN diode controls the amount of signal attenuation. For example, if PIN diode current flow is increased, more RF signal is shunted or bypassed to ground. A12C12 provides the RF ground and also isolates from ground the variable dc from the REF LEVEL FINE control. When the REF LEVEL FINE control is fully clockwise, the PIN diode is at minimum conduction, and maximum signal is applied to the base of A12Q7. Conversely, when the REF LEVEL FINE control is fully counterclockwise, the PIN diode is at maximum conduction and minimum signal is applied to A12Q7.

Step Gain Amplifiers (B) (C) (D)

Buffer amplifier A12Q7 operates in an emitter-follower configuration and provides isolation between the 0 – 12 dB control and the 10 dB amplifier.

The three step gain amplifiers can be considered as operational amplifiers. An equivalent circuit for the three stages is shown in Figure 8-45. The gain for each amplifier is $A_v = R_f/R_i$. The feedback resistance (R_f) for the 10 dB amplifier is A12R26, 562 ohms; and for the 20 dB amplifiers it is A12R32 and A12R38, 750 ohms. The input resistance R_i is a combination of a fixed series resistance (56.2 ohms) and the controlled resistance of the PIN diodes. The resistance of the PIN diodes is approximately 10 to 1000 ohms and increases as the forward bias current is decreased from 100 mA to 1 μ A. R_i is approximately 260 ohms for the 10 dB amplifier and approximately 83 ohms for the 20 dB amplifiers.

Selection of the correct combination of step gain amplifiers is accomplished with front panel REF LEVEL dBm switch A2S1. Rotating the switch grounds the emitter circuit of the selected amplifier(s) allowing current to flow through the PIN diode(s). The possible switch combinations allow the gain to vary from unity (all switches open) to 50 dB maximum gain with all three emitter circuits grounded.

A TEST/NORM switch, A12S1, is included in the emitter paths of the 20 dB step gain amplifiers. In the TEST position, the switch defeats the two 20 dB amplifier stages, providing a fixed 10 dB of gain for use when making LOG amplifier adjustments.

Bandpass Filter (E)

The output of the step-gain amplifiers is coupled through a two-section bandpass filter. The bandpass filter consists of A12L9, A12L10, A12C24, and A12C25 and provides rejection of signals outside the region of 21.4 MHz.

+ 19.5V Regulator (F)

The +19.5V regulator consists of series regulator A12Q13, driver A12Q12, and reference amplifier A12Q10 and Q11. Zener diode A12VR1 provides a +6.2V reference for the base of Q11. Q10 senses the +19.5V output across resistors A12R45, R46, and R7, the +19.5V adjustment. Should the output voltage start to drop below +19.5V, Q10 will start to turn off. This will turn on Q11 which turns on Q12 and Q13, raising the output back to +19.5V. L11 and C27 filter the +19.5V output. C26 between the collector and emitter of Q12 is used to stabilize the feedback gain at high frequencies.

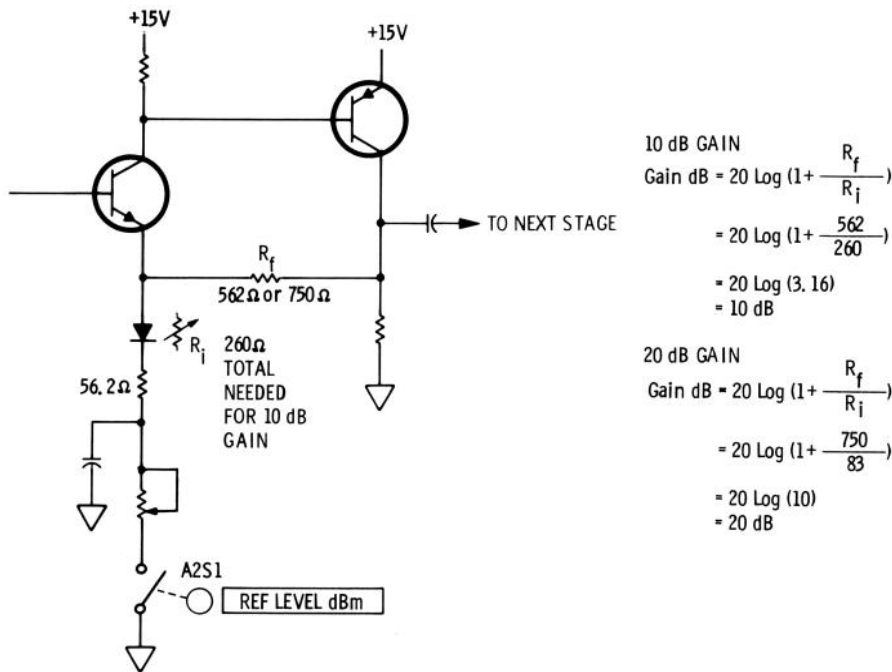

FIGURE 8-45. EQUIVALENT CIRCUIT FOR STEP GAIN AMPLIFIERS

TABLE 8-12. A12 STEP GAIN ASSEMBLY, REPLACEABLE PARTS (1 OF 2)

Reference Designation	HP Part Number	C D	Qty	Description	Mfr Code	Mfr Part Number
A12	08558-60012 08558-60073	5 8	1 1	STEP GAIN ASSEMBLY STEP GAIN ASSEMBLY (OPTION 001, 002)	28480 28480	08558-60012 08558-60073
A12C1	0160-2055	9	19	CAPACITOR-FXD .01UF +80-20% 100VDC CER	28480	0160-2055
A12C2	0160-2055	9		CAPACITOR-FXD .01UF +80-20% 100VDC CER	28480	0160-2055
A12C3	0160-2055	9		CAPACITOR-FXD .01UF +30-20% 100VDC CER	28480	0160-2055
A12C4	0160-2055	9		CAPACITOR-FXD .01UF +80-20% 100VDC CER	28480	0160-2055
A12C5	0160-2055	9		CAPACITOR-FXD .01UF +80-20% 100VDC CER	28480	0160-2055
A12C6	0160-2055	9		CAPACITOR-FXD .01UF +80-20% 100VDC CER	28480	0160-2055
A12C7	0160-2055	9		CAPACITOR-FXD .01UF +80-20% 100VDC CER	28480	0160-2055
A12C8	0160-2055	9		CAPACITOR-FXD .01UF +80-20% 100VDC CER	28480	0160-2055
A12C9	0160-2055	9		CAPACITOR-FXD .01UF +80-20% 100VDC CER	28480	0160-2055
A12C10	0160-2055	9		CAPACITOR-FXD .01UF +80-20% 100VDC CER	28480	0160-2055
A12C11	0160-2055	9		CAPACITOR-FXD .01UF +80-20% 100VDC CER	28480	0160-2055
A12C12	0180-0291	3	2	CAPACITOR-FXD 1UF+-10% 35VDC TA	56289	150D105X9035A2
A12C13	0160-2055	9		CAPACITOR-FXD .01UF +30-20% 100VDC CER	28480	0160-2055
A12C14	0160-2055	9		CAPACITOR-FXD .01UF +80-20% 100VDC CER	28480	0160-2055
A12C15	0160-2055	9		CAPACITOR-FXD .01UF +80-20% 100VDC CER	28480	0160-2055
A12C16	0160-3457	7	3	CAPACITOR-FXD 2000PF +-10% 250VDC CER	28480	0160-3457
A12C17	0160-2055	9		CAPACITOR-FXD .01UF +80-20% 100VDC CER	28480	0160-2055
A12C18	0160-2055	9		CAPACITOR-FXD .01UF +80-20% 100VDC CER	28480	0160-2055
A12C19	0160-3457	7		CAPACITOR-FXD 2000PF +-10% 250VDC CER	28480	0160-3457
A12C20	0160-2055	9		CAPACITOR-FXD .01UF +80-20% 100VDC CER	28480	0160-2055
A12C21	0160-2055	9		CAPACITOR-FXD .01UF +80-20% 100VDC CER	28480	0160-2055
A12C22	0160-3457	7		CAPACITOR-FXD 2000PF +-10% 250VDC CER	28480	0160-3457
A12C23	0160-2055	9		CAPACITOR-FXD .01UF +80-20% 100VDC CER	28480	0160-2055
A12C24	0160-2199	2		CAPACITOR-FXD 30PF +-5% 300VDC MICA	28480	0160-2199
A12C25*	0160-2199	2	2	CAPACITOR-FXD 30PF +-5% 300VDC MICA	28480	0160-2199
A12C25	0160-2307	4	1	CAPACITOR-FXD 47PF +-5% 300VDC MICA (OPTION 001, 002)	28480	0160-2307
A12C26	0140-0194	1	1	CAPACITOR-FXD 110PF +-5% 300VDC MICA	72136	DM15F111J0300VVC1CR
A12C27	0180-0291	3		CAPACITOR-FXD 1UF+-10% 35VDC TA	56289	150D105X9035A2
A12CR1	1901-0050	3	2	DIODE-SWITCHING 80V 200MA 2NS DO-35	28480	1901-0050
A12CR2	1901-0050	3		DIODE-SWITCHING 80V 200MA 2NS DO-35	28480	1901-0050
A12CR3	1901-1070	9	4	DIODE-PIN 110V	28480	1901-1070
A12CR4	1901-1070	9		DIODE-PIN 110V	28480	1901-1070
A12CR5	1901-1070	9		DIODE-PIN 110V	28480	1901-1070
A12CR6	1901-1070	9		DIODE-PIN 110V	28480	1901-1070
A12E1	9170-0029	3	3	CORE-SHIELDING BEAD	28480	9170-0029
A12E2	9170-0029	3		CORE-SHIELDING BEAD	28480	9170-0029
A12E3	9170-0029	3		CORE-SHIELDING BEAD	28480	9170-0029
A12L1	9140-0179	1	8	INDUCTOR RF-CH-MLD 22UH 10% .166DX.385LG	28480	9140-0179
A12L2	9140-0179	1		INDUCTOR RF-CH-MLD 22UH 10% .166DX.385LG	28480	9140-0179
A12L3	9140-0179	1		INDUCTOR RF-CH-MLD 22UH 10% .166DX.385LG	28480	9140-0179
A12L4	9140-0179	1		INDUCTOR RF-CH-MLD 22UH 10% .166DX.385LG	28480	9140-0179
A12L5	9140-0179	1		INDUCTOR RF-CH-MLD 22UH 10% .166DX.385LG	28480	9140-0179
A12L6	9140-0179	1		INDUCTOR RF-CH-MLD 22UH 10% .166DX.385LG	28480	9140-0179
A12L7	9140-0179	1		INDUCTOR RF-CH-MLD 22UH 10% .166DX.385LG	28480	9140-0179
A12L8	9140-0179	1		INDUCTOR RF-CH-MLD 22UH 10% .166DX.385LG	28480	9140-0179
A12L9	9100-2260	1	1	INDUCTOR RF-CH-MLD 1.8UH 10% .105DX.26LG	28480	9100-2260
A12L10	9140-0158	6	1	INDUCTOR RF-CH-MLD 1UH 10% .105DX.26LG	28480	9140-0158
A12L11	9100-2552	4	1	INDUCTOR RF-CH-MLD 15UH 10% .161DX.385LG	28480	9100-2552
A12Q1	1853-0007	7	7	TRANSISTOR PNP 2N3251 SI TO-18 PD=360MW	04713	2N3251
A12Q2	1854-0345	8	3	TRANSISTOR NPN 2N5179 SI TO-72 PD=200MW	04713	2N5179
A12Q3	1853-0007	7		TRANSISTOR PNP 2N3251 SI TO-18 PD=360MW	04713	2N3251
A12Q4	1854-0345	8		TRANSISTOR NPN 2N5179 SI TO-72 PD=200MW	04713	2N5179
A12Q5	1853-0007	7		TRANSISTOR PNP 2N3251 SI TO-18 PD=360MW	04713	2N3251
A12Q6	1854-0345	8		TRANSISTOR NPN 2N5179 SI TO-72 PD=200MW	04713	2N5179
A12Q7	1853-0007	7		TRANSISTOR PNP 2N3251 SI TO-18 PD=360MW	04713	2N3251
A12Q8	1853-0007	7		TRANSISTOR PNP 2N3251 SI TO-18 PD=360MW	04713	2N3251
A12Q9	1853-0007	7		TRANSISTOR PNP 2N3251 SI TO-18 PD=360MW	04713	2N3251
A12Q10	1853-0882	8	2	TRANSISTOR NPN PD=300MW FT=200MHZ	28480	1854-0882
A12Q11	1854-0882	8		TRANSISTOR NPN PD=300MW FT=200MHZ	28480	1854-0882
A12Q12	1853-0007	7		TRANSISTOR PNP 2N3251 SI TO-18 PD=360MW	04713	2N3251
A12Q13	1853-0213	7	1	TRANSISTOR PNP 2N4236 SI TO-5 PD=1W	04713	2N4236
A12R1	2100-3103	6	3	RESISTOR-TRMR 10K 10% C SIDE-ADJ 17-TRN	02111	43P103
A12R2	2100-3103	6		RESISTOR-TRMR 10K 10% C SIDE-ADJ 17-TRN	02111	43P103
A12R3	2100-3054	6	1	RESISTOR-TRMR 50K 10% C SIDE-ADJ 17-TRN	02111	43P503
A12R4	2100-3061	5	1	RESISTOR-TRMR 500K 10% C SIDE-ADJ 17-TRN	02111	43P504
A12R5	2100-3103	6		RESISTOR-TRMR 10K 10% C SIDE-ADJ 17-TRN	02111	43P103

*Indicates factory selected value

TABLE 8-12. A12 STEP GAIN ASSEMBLY, REPLACEABLE PARTS (2 OF 2)

Reference Designation	HP Part Number	C D	Qty	Description	Mfr Code	Mfr Part Number
A12R6	2100-3056	0	1	RESISTOR-TRMR 5K 10% C SIDE-ADJ 17-TRN	02111	43P502
A12R7	2100-1757	2	1	RESISTOR-TRMR 500 5% MW SIDE-ADJ 1-TRN	28480	2100-1757
A12R8	0757-0288	1	2	RESISTOR 9.09K 1% .125W F TC=0+-100	19701	MF4C1/8-T0-9091-F
A12R9	0698-3457	6	1	RESISTOR 316K 1% .125W F TC=0+-100	20480	0698-3457
A12R10	0757-0346	2	4	RESISTOR 10 1% .125W F TC=0+-100	24546	C4-1/8-T0-10R0-F
A12R11	0757-0279	0	5	RESISTOR 3.16K 1% .125W F TC=0+-100	24546	C4-1/8-T0-3161-F
A12R12	0698-3444	1	4	RESISTOR 316 1% .125W F TC=0+-100	24546	C4-1/8-T0-316R-F
A12R13	0757-0288	1		RESISTOR 9.09K 1% .125W F TC=0+-100	19761	MF4C1/8-T0-9091-F
A12R14	0757-0395	1	4	RESISTOR 56.2 1% .125W F TC=0+-100	24546	C4-1/8-T0-56R2-F
A12R15	0757-0346	2		RESISTOR 10 1% .125W F TC=0+-100	24546	C4-1/8-T0-10R0-F
A12R16	0757-0346	2		RESISTOR 10 1% .125W F TC=0+-100	24546	C4-1/8-T0-10R0-F
A12R17	0757-0290	5	3	RESISTOR 6.19K 1% .125W F TC=0+-100	19701	MF4C1/8-T0-6191-F
A12R18	0757-0346	2		RESISTOR 10 1% .125W F TC=0+-100	24546	C4-1/8-T0-10R0-F
A12R19	0757-0296	5		RESISTOR 6.19K 1% .125W F TC=0+-100	19701	MF4C1/8-T0-6191-F
A12R20	0757-0279	0		RESISTOR 3.16K 1% .125W F TC=0+-100	24546	C4-1/8-T0-3161-F
A12R21	0698-3162	0	4	RESISTOR 46.4K 1% .125W F TC=0+-100	24546	C4-1/8-T0-4642-F
A12R22	0757-0279	0		RESISTOR 3.16K 1% .125W F TC=0+-100	24546	C4-1/8-T0-316R-F
A12R23	0698-3444	1		RESISTOR 316 1% .125W F TC=0+-100	24546	C4-1/8-T0-316R-F
A12R24	0757-0395	1		RESISTOR 56.2 1% .125W F TC=0+-100	24546	C4-1/8-T0-56R2-F
A12R25	0757-0280	3	6	RESISTOR 1K 1% .125W F TC=0+-100	24546	C4-1/8-T0-1001-F
A12R26	0757-0417	0	1	RESISTOR 562 1% .125W F TC=0+-100	24546	C4-1/8-T0-562R-F
A12R26	0757-0419	0	1	RESISTOR 681 1% .125W F TC=0+-100 (OPTION 001, 002)	24546	C4-1/8-T0-681R-F
A12R27	0757-0280	3		RESISTOR 1K 1% .125W F TC=0+-100	24546	C4-1/8-T0-1001-F
A12R28	0757-0279	0		RESISTOR 3.16K 1% .125W F TC=0+-100	24546	C4-1/8-T0-3161-F
A12R29	0698-3444	1		RESISTOR 316 1% .125W F TC=0+-100	24546	C4-1/8-T0-316R-F
A12R30	0757-0395	1		RESISTOR 56.2 1% .125W F TC=0+-100	24546	C4-1/8-T0-56R2-F
A12R31	0757-0280	3		RESISTOR 1K 1% .125W F TC=0+-100	24546	C4-1/8-T0-1001-F
A12R32	0757-0420	3	2	RESISTOR 750 1% .125W F TC=0+-100	24546	C4-1/8-T0-751-F
A12R33	0757-0280	3		RESISTOR 1K 1% .125W F TC=0+-100	24546	C4-1/8-T0-1001-F
A12R34	0757-0279	0		RESISTOR 3.16K 1% .125W F TC=0+-100	24546	C4-1/8-T0-3161-F
A12R35	0698-3444	1		RESISTOR 316 1% .125W F TC=0+-100	24546	C4-1/8-T0-316R-F
A12R36	0757-0395	1		RESISTOR 56.2 1% .125W F TC=0+-100	24546	C4-1/8-T0-56R2-F
A12R37	0757-0280	3		RESISTOR 1K 1% .125W F TC=0+-100	24546	C4-1/8-T0-1001-F
A12R38	0757-0420	3		RESISTOR 750 1% .125W F TC=0+-100	24546	C4-1/8-T0-751-F
A12R39	0757-0280	3		RESISTOR 1K 1% .125W F TC=0+-100	24546	C4-1/8-T0-1001-F
A12R40	0698-3440	7	1	RESISTOR 196 1% .125W F TC=0+-100	24546	C4-1/8-T0-196R-F
A12R41	0757-0274	5	2	RESISTOR 1.21K 1% .125W F TC=0+-100	24546	C4-1/8-T0-1211-F
A12R42	0757-0274	5		RESISTOR 1.21K 1% .125W F TC=0+-100	24546	C4-1/8-T0-1211-F
A12R43	0698-3151	7	3	RESISTOR 2.87K 1% .125W F TC=0+-100	24546	C4-1/8-T0-2871-F
A12R44	0698-3151	7		RESISTOR 2.87K 1% .125W F TC=0+-100	24546	C4-1/8-T0-2871-F
A12R45	0757-0290	5		RESISTOR 6.19K 1% .125W F TC=0+-100	19701	MF4C1/8-T0-6191-F
A12R46	0698-3151	7		RESISTOR 2.87K 1% .125W F TC=0+-100	24546	C4-1/8-T0-2871-F
A12R47	0698-3162	0		RESISTOR 46.4K 1% .125W F TC=0+-100	24546	C4-1/8-T0-4642-F
A12R48	0698-3162	0		RESISTOR 46.4K 1% .125W F TC=0+-100	24546	C4-1/8-T0-4642-F
A12R49	0698-3162	0		RESISTOR 46.4K 1% .125W F TC=0+-100	24546	C4-1/8-T0-4642-F
A12S1	3101-0973	5	1	SWITCH-SL DPDT MINTR .5A 125VAC/DC PC	28480	3101-0973
A12TP1	1251-0600	0	9	CONNECTOR-SGL CONT PIN 1.14-MM-BSC-SZ SQ	28480	1251-0600
A12TP2	1251-0600	0		CONNECTOR-SGL CONT PIN 1.14-MM-BSC-SZ SQ	28480	1251-0600
A12TP3	1251-0600	0		CONNECTOR-SGL CONT PIN 1.14-MM-BSC-SZ SQ	28480	1251-0600
A12TP4	1251-0600	0		CONNECTOR-SGL CONT PIN 1.14-MM-BSC-SZ SQ	28480	1251-0600
A12TP5	1251-0600	0		CONNECTOR-SGL CONT PIN 1.14-MM-BSC-SZ SQ	28480	1251-0600
A12TP6	1251-0600	0		CONNECTOR-SGL CONT PIN 1.14-MM-BSC-SZ SQ	28480	1251-0600
A12TP7	1251-0600	0		CONNECTOR-SGL CONT PIN 1.14-MM-BSC-SZ SQ	28480	1251-0600
A12TP8	1251-0600	0		CONNECTOR-SGL CONT PIN 1.14-MM-BSC-SZ SQ	28480	1251-0600
A12TP9	1251-0600	0		CONNECTOR-SGL CONT PIN 1.14-MM-BSC-SZ SQ	28480	1251-0600
A12VR1	1902-0033	4	1	DIODE-ZNR 1N823 6.2V 5% DO-7 PD=.4W	24046	1N823
				MISCELLANEOUS		
	1200-0173	5	1	INSULATOR-XSTR DAP-GL	28480	1200-0173

*Indicates factory selected value

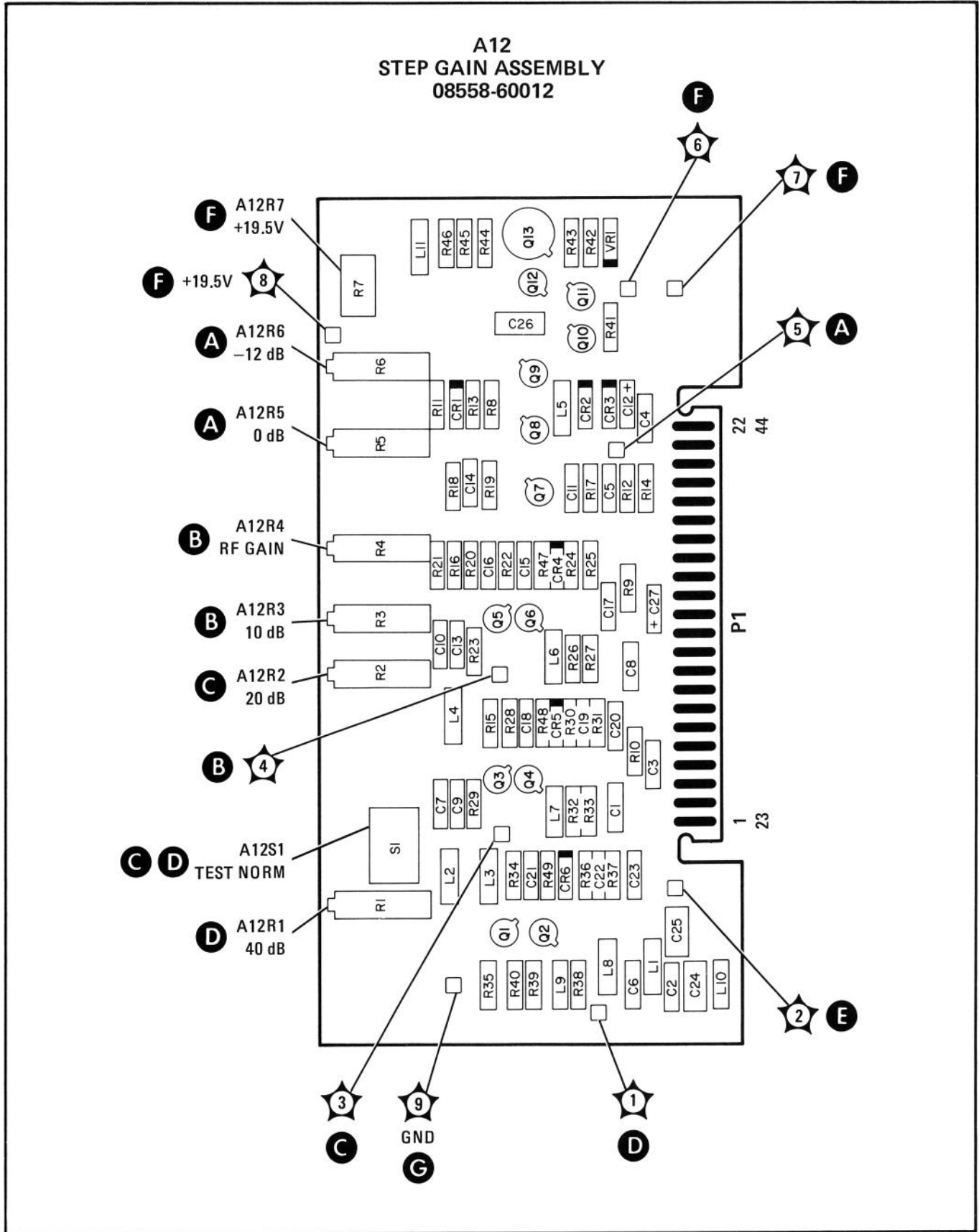

FIGURE 8-46. A12 STEP GAIN ASSEMBLY, COMPONENT LOCATIONS

A13 BANDWIDTH FILTER NO. 2, CIRCUIT DESCRIPTION

Bandwidth Filter No. 2 Assembly A13 is very similar to Bandwidth Filter No. 1 Assembly A11, and corresponding components have the same reference designators. The differences between the two assemblies are in the TO/FROM designations listed on the schematic diagrams. Refer to the Bandwidth Filter No. 1 Assembly A11 circuit description for complete information on circuit operation.

TABLE 8-13. A13 BANDWIDTH FILTER NO. 2 ASSEMBLY, REPLACEABLE PARTS (1 OF 3)

Reference Designation	HP Part Number	C D	Qty	Description	Mfr Code	Mfr Part Number
A13	00559-60050	0	1	BANDWIDTH FILTER NO. 2 ASSEMBLY	20400	00559-60050
A13C1	0160-2055	9	30	CAPACITOR-FXD .01UF +80-20% 100VDC CER	20400	0160-2055
A13C2	0160-0127	2	1	CAPACITOR-FXD 1UF +-20% 25VDC CER	20400	0160-0127
A13C3				NOT ASSIGNED		
A13C4	0160-2055	9		CAPACITOR-FXD .01UF +80-20% 100VDC CER	20400	0160-2055
A13C5	0160-2055	9		CAPACITOR-FXD .01UF +80-20% 100VDC CER	20400	0160-2055
A13C6	0160-2055	9		CAPACITOR-FXD .01UF +80-20% 100VDC CER	20400	0160-2055
A13C7	0160-2055	9		CAPACITOR-FXD .01UF +80-20% 100VDC CER	20400	0160-2055
A13C8	0160-2207	3	2	CAPACITOR-FXD 300PF +-5% 300VDC MICA	20400	0160-2207
A13C9	0160-2055	9		CAPACITOR-FXD .01UF +80-20% 100VDC CER	20400	0160-2055
A13C10	0160-2055	9		CAPACITOR-FXD .01UF +80-20% 100VDC CER	20400	0160-2055
A13C11	0160-2055	9		CAPACITOR-FXD .01UF +80-20% 100VDC CER	20400	0160-2055
A13C12	0160-2055	9		CAPACITOR-FXD .01UF +80-20% 100VDC CER	20400	0160-2055
A13C13	0160-3456	6	3	CAPACITOR-FXD 1000PF +-10% 1KVDC CER	20400	0160-3456
A13C14	0160-2249	3	2	CAPACITOR-FXD 4.7PF +-1.25PF 500VDC CER	20400	0160-2249
A13C15	0121-0059	7	2	CAPACITOR-V TRMR-CER 2-8PF 350V PC-MTG	52763	304324 2/8PF NPO
A13C16*	0160-0134	1	4	CAPACITOR-FXD 220PF +-5% 300VDC MICA	20400	0160-0134
A13C17	0160-2055	9		CAPACITOR-FXD .01UF +80-20% 100VDC CER	20400	0160-2055
A13C18	0160-2055	9		CAPACITOR-FXD .01UF +80-20% 100VDC CER	20400	0160-2055
A13C19	0160-2055	9		CAPACITOR-FXD .01UF +80-20% 100VDC CER	20400	0160-2055
A13C20*	0160-0134	1		CAPACITOR-FXD 220PF +-5% 300VDC MICA	20400	0160-0134
A13C21	0160-0437	7	2	CAPACITOR-FXD 12PF +-5% 500VDC CER	20400	0160-0437
A13C22	0160-4084	8	3	CAPACITOR-FXD .1UF +-20% 50VDC CER	20400	0160-4084
A13C23	0121-0036	0	2	CAPACITOR-V TRMR-CER 5.5-18PF 350V	52763	304324 5.5/18PF NPO
A13C24	0160-2055	9		CAPACITOR-FXD .01UF +80-20% 100VDC CER	20400	0160-2055
A13C25	0121-0446	6	2	CAPACITOR-V TRMR-CER 4.5-20PF 160V	20400	0121-0446
A13C26	0160-2055	9		CAPACITOR-FXD .01UF +80-20% 100VDC CER	20400	0160-2055
A13C27	0160-2055	9		CAPACITOR-FXD .01UF +80-20% 100VDC CER	20400	0160-2055
A13C28	0160-2055	9		CAPACITOR-FXD .01UF +80-20% 100VDC CER	20400	0160-2055
A13C29	0160-3456	6		CAPACITOR-FXD 1000PF +-10% 1KVDC CER	20400	0160-3456
A13C30	0160-2055	9		CAPACITOR-FXD .01UF +80-20% 100VDC CER	20400	0160-2055
A13C31	0160-4298	6	1	CAPACITOR-FXD 4700PF +-20% 250VDC CER	56289	C067F251H472M922-CDH
A13C32	0160-4084	8		CAPACITOR-FXD .1UF +-20% 50VDC CER	20400	0160-4084
A13C33	0160-2207	3		CAPACITOR-FXD 300PF +-5% 300VDC MICA	20400	0160-2207
A13C34	0160-2055	9		CAPACITOR-FXD .01UF +80-20% 100VDC CER	20400	0160-2055
A13C35	0160-2055	9		CAPACITOR-FXD .01UF +80-20% 100VDC CER	20400	0160-2055
A13C36	0160-2055	9		CAPACITOR-FXD .01UF +80-20% 100VDC CER	20400	0160-2055
A13C37	0160-2249	3		CAPACITOR-FXD 4.7PF +-1.25PF 500VDC CER	20400	0160-2249
A13C38	0121-0059	7		CAPACITOR-V TRMR-CER 2-8PF 350V PC-MTG	52763	304324 2/8PF NPO
A13C39				NOT ASSIGNED		
A13C40	0160-2055	9		CAPACITOR-FXD .01UF +80-20% 100VDC CER	20400	0160-2055
A13C41	0160-3456	6		CAPACITOR-FXD 1000PF +-10% 1KVDC CER	20400	0160-3456
A13C42	0160-2055	9		CAPACITOR-FXD .01UF +80-20% 100VDC CER	20400	0160-2055
A13C43*	0160-0134	1		CAPACITOR-FXD 220PF +-5% 300VDC MICA	20400	0160-0134
A13C44	0160-0437	7		CAPACITOR-FXD 12PF +-5% 500VDC CER	20400	0160-0437
A13C45	0121-0036	0		CAPACITOR-V TRMR-CER 5.5-18PF 350V	52763	304324 5.5/18PF NPO
A13C46	0160-4084	8		CAPACITOR-FXD .1UF +-20% 50VDC CER	20400	0160-4084
A13C47	0160-2055	9		CAPACITOR-FXD .01UF +80-20% 100VDC CER	20400	0160-2055
A13C48	0160-2055	9		CAPACITOR-FXD .01UF +80-20% 100VDC CER	20400	0160-2055
A13C49	0160-2055	9		CAPACITOR-FXD .01UF +80-20% 100VDC CER	20400	0160-2055
A13C50	0160-2055	9		CAPACITOR-FXD .01UF +80-20% 100VDC CER	20400	0160-2055
A13C51	0160-2055	9		CAPACITOR-FXD .01UF +80-20% 100VDC CER	20400	0160-2055
A13C52	0160-2055	9		CAPACITOR-FXD .01UF +80-20% 100VDC CER	20400	0160-2055
A13C53	0160-2055	9		CAPACITOR-FXD .01UF +80-20% 100VDC CER	20400	0160-2055
A13C54	0121-0446	6		CAPACITOR-V TRMR-CER 4.5-20PF 160V	20400	0121-0446
A13C55	0160-2055	9		CAPACITOR-FXD .01UF +80-20% 100VDC CER	20400	0160-2055
A13C56-				NOT ASSIGNED		
A13C59				NOT ASSIGNED		
A13C60	0160-2055	9		CAPACITOR-FXD .01UF +80-20% 100VDC CER	20400	0160-2055
A13C61	0160-2055	9		CAPACITOR-FXD .01UF +80-20% 100VDC CER	20400	0160-2055
A13C62	0160-2055	9		CAPACITOR-FXD .01UF +80-20% 100VDC CER	20400	0160-2055
A13C63	0160-2055	9		CAPACITOR-FXD .01UF +80-20% 100VDC CER	20400	0160-2055
A13C64*	0160-0134	1		CAPACITOR-FXD 220PF +-5% 300VDC MICA	20400	0160-0134
A13C65	0160-2055	9		CAPACITOR-FXD .01UF +80-20% 100VDC CER	20400	0160-2055
A13C66	0160-2055	9		CAPACITOR-FXD .01UF +80-20% 100VDC CER	20400	0160-2055
A13C67	0160-2055	9		CAPACITOR-FXD .01UF +80-20% 100VDC CER	20400	0160-2055
A13C68	0160-2250	4	1	CAPACITOR-FXD 11PF +-5% 500VDC CER 04-30	20400	0160-2250
A13C69	0160-2055	9		CAPACITOR-FXD .01UF +80-20% 100VDC CER	20400	0160-2055
A13C70-				NOT ASSIGNED		
A13C72				NOT ASSIGNED		
A13C73	0121-0452	4	2	CAPACITOR-V TRMR-AIR 1.3-5.4PF 175V	74970	187-0103-028

*Indicates factory selected value

TABLE 8-13. A13 BANDWIDTH FILTER NO. 2 ASSEMBLY, REPLACEABLE PARTS (2 OF 3)

Reference Designation	HP Part Number	C D	Qty	Description	Mfr Code	Mfr Part Number
A13C74	0121-0452	4		CAPACITOR -V TRMR -AIR 1.3-5.4PF 175V	74970	187-3103-028
A13CR1	1901-0047	8	6	DIODE-SWITCHING 20V 75MA 10NS	28480	1901-0047
A13CR2	1901-0047	8		DIODE-SWITCHING 20V 75MA 10NS	28480	1901-0047
A13CR3	1901-1070	9	5	DIODE-PIN 110V	28480	1901-1070
A13CR4	1901-1070	9		DIODE-PIN 110V	28480	1901-1070
A13CR5	1901-1070	9		DIODE-PIN 110V	28480	1901-1070
A13CR6	1901-0535	9	5	DIODE-SM SIG SCHOTTKY	28480	1901-0535
A13CR8	1901-0535	9		DIODE-SM SIG SCHOTTKY	28480	1901-0535
A13CR9	1901-0047	8		DIODE-SWITCHING 20V 75MA 10NS	28480	1901-0047
A13CR10	1901-0047	8		DIODE-SWITCHING 20V 75MA 10NS	28480	1901-0047
A13CR11	1901-1070	9		DIODE-PIN 110V	28480	1901-1070
A13CR12	1901-1070	9		DIODE-PIN 110V	28480	1901-1070
A13CR13	1901-0047	8		DIODE-SWITCHING 20V 75MA 10NS	28480	1901-0047
A13CR14	1901-0535	9		DIODE-SM SIG SCHOTTKY	28480	1901-0535
A13CR15	1901-0535	9		DIODE-SM SIG SCHOTTKY	28480	1901-0535
A13CR16	1901-0047	8		DIODE-SWITCHING 20V 75MA 10NS	28480	1901-0047
A13CR17	1901-0535	9		DIODE-SM SIG SCHOTTKY	28480	1901-0535
A13E1	9170-0029	3	8	CORE-SHIELDING BEAD	28480	9170-0029
A13E2	9170-0029	3		CORE-SHIELDING BEAD	28480	9170-0029
A13E3	9170-0029	3		CORE-SHIELDING BEAD	28480	9170-0029
A13E4	9170-0029	3		CORE-SHIELDING BEAD	28480	9170-0029
A13E5	9170-0029	3		CORE-SHIELDING BEAD	28480	9170-0029
A13E6	9170-0029	3		CORE-SHIELDING BEAD	28480	9170-0029
A13E7	9170-0029	3		CORE-SHIELDING BEAD	28480	9170-0029
A13E8	9170-0029	3		CORE-SHIELDING BEAD	28480	9170-0029
A13L1	9140-0112	2	1	INDUCTOR RF-CH-MLD 4.7UH 10%	28480	9140-0112
A13L2	9100-1641	0	1	INDUCTOR RF-CH-MLD 240UH 5% .166DX.385LG	28480	9100-1641
A13L3	9140-0114	4	2	INDUCTOR RF-CH-MLD 10UH 10% .166DX.385LG	28480	9140-0114
A13L4	9100-1624	9	3	INDUCTOR RF-CH-MLD 30UH 5% .166DX.385LG	28480	9100-1624
A13L5	9140-0179	1	2	INDUCTOR RF-CH-MLD 22UH 10% .166DX.385LG	28480	9140-0179
A13L6	9100-2813	0	2	INDUCTOR 400NH 10% .312DX1.016LG Q=150	28480	9100-2813
A13L7	9140-0399	7	2	INDUCTOR RF-CH-MLD 2.2UH 5% .166DX.385LG	28480	9140-0399
A13L8	9140-0178	0	1	INDUCTOR RF-CH-MLD 12UH 10% .166DX.385LG	28480	9140-0178
A13L9	9100-1619	2	2	INDUCTOR RF-CH-MLD 6.8UH 10%	28480	9100-1619
A13L10	9140-0114	4	2	INDUCTOR RF-CH-MLD 10UH 10% .166DX.385LG	28480	9140-0114
A13L11	9100-1624	9		INDUCTOR RF-CH-MLD 30UH 5% .166DX.385LG	28480	9100-1624
A13L12	9140-0179	1		INDUCTOR RF-CH-MLD 22UH 10% .166DX.385LG	28480	9140-0179
A13L13	9140-0399	7		INDUCTOR RF-CH-MLD 2.2UH 5% .166DX.385LG	28480	9140-0399
A13L14	9100-1620	5	1	INDUCTOR RF-CH-MLD 15UH 10% .166DX.385LG	28480	9100-1620
A13L15	9100-2813	0		INDUCTOR 400NH 10% .312DX1.016LG Q=150	28480	9100-2813
A13L16	9140-0144	0	2	INDUCTOR RF-CH-MLD 4.7UH 10% .105DX.26LG	28480	9140-0144
A13L17	9100-1624	9		INDUCTOR RF-CH-MLD 30UH 5% .166DX.385LG	28480	9100-1624
A13L18	9100-1619	2		INDUCTOR RF-CH-MLD 6.8UH 10%	28480	9100-1619
A13L19	9140-0144	0		INDUCTOR RF-CH-MLD 4.7UH 10% .105DX.26LG	28480	9140-0144
A13Q1	1854-0345	8	1	TRANSISTOR NPN 2N5179 SI TO-72 PD=200MW	04713	2N5179
A13Q2	1854-0404	0	2	TRANSISTOR NPN SI TO-18 PD=360MW	28480	1854-0404
A13Q3	1853-0007	7	5	TRANSISTOR PNP 2N3251 SI TO-18 PD=360MW	04713	2N3251
A13Q4	1853-0007	7		TRANSISTOR PNP 2N3251 SI TO-18 PD=360MW	04713	2N3251
A13Q5	1855-0267	5	2	TRANSISTOR J-FET N-CHAN D-MODE TO-92 SI	28480	1855-0267
A13Q6	1853-0007	7		TRANSISTOR PNP 2N3251 SI TO-18 PD=360MW	04713	2N3251
A13Q7	1854-0404	0		TRANSISTOR NPN SI TO-18 PD=360MW	28480	1854-0404
A13Q8	1853-0007	7		TRANSISTOR PNP 2N3251 SI TO-18 PD=360MW	04713	2N3251
A13Q9	1855-0267	5		TRANSISTOR J-FET N-CHAN D-MODE TO-92 SI	28480	1855-0267
A13Q10	1853-0007	7		TRANSISTOR PNP 2N3251 SI TO-18 PD=360MW	04713	2N3251
A13R1	0757-0444	1		RESISTOR 12.1K 1% .125W F TC=0+-100	24546	C4-1/8-T0-1212-F
A13R2	0698-3156	2	1	RESISTOR 14.7K 1% .125W F TC=0+-100	24546	C4-1/8-T0-1472-F
A13R3	0757-0402	1	2	RESISTOR 110 1% .125W F TC=0+-100	24546	C4-1/8-T0-111-F
A13R4	0757-0442	9	8	RESISTOR 10K 1% .125W F TC=0+-100	24546	C4-1/8-T0-1002-F
A13R5	0757-0405	4	1	RESISTOR 162 1% .125W F TC=0+-100	24546	C4-1/8-T0-162R-F
A13R6	0698-3431	6	1	RESISTOR 23.7 1% .125W F TC=0+-100	03088	PME55-1/8-T0-23R7-F
A13R7*	0698-8821	8	1	RESISTOR 5.62 1% .125W F TC=0+-100	28480	0698-8821
A13R8	0757-0401	0	3	RESISTOR 100 1% .125W F TC=0+-100	24546	C4-1/8-T0-101-F
A13R9	0757-0439	4	1	RESISTOR 6.81K 1% .125W F TC=0+-100	24546	C4-1/8-T0-6811-F
A13R10	0757-1074	9	1	RESISTOR 1.47K 1% .125W F TC=0+-100	24546	C4-1/8-T0-1471-F
A13R11	0757-0440	7	1	RESISTOR 7.5K 1% .125W F TC=0+-100	24546	C4-1/8-T0-7501-F
A13R12	0757-0447	4	1	RESISTOR 16.2K 1% .125W F TC=0+-100	24546	C4-1/8-T0-1622-F
A13R13	0678-0082	7	1	RESISTOR 464 1% .125W F TC=0+-100	24546	C4-1/8-T0-4640-F
A13R14	0757-0346	2	4	RESISTOR 10 1% .125W F TC=0+-100	24546	C4-1/8-T0-10R0-F
A13R15	0698-3440	7	2	RESISTOR 196 1% .125W F TC=0+-100	24546	C4-1/8-T0-196R-F
A13R16	0757-0419	0	2	RESISTOR 681 1% .125W F TC=0+-100	24546	C4-1/8-T0-681R-F
A13R17	0698-3442	9	2	RESISTOR 237 1% .125W F TC=0+-100	24546	C4-1/8-T0-237R-F
A13R18	0698-3154	0	2	RESISTOR 4.22K 1% .125W F TC=0+-100	24546	C4-1/8-T0-4221-F
A13R19*	0698-3155	1	2	RESISTOR 4.64K 1% .125W F TC=0+-100	24546	C4-1/8-T0-4641-F
A13R20	0757-0442	9		RESISTOR 10K 1% .125W F TC=0+-100	24546	C4-1/8-T0-1002-F

*Indicates factory selected value

TABLE 8-13. A13 BANDWIDTH FILTER NO. 2 ASSEMBLY, REPLACEABLE PARTS (3 OF 3)

Reference Designation	HP Part Number	C D	Qty	Description	Mfr Code	Mfr Part Number
A13R21	0757-0442	9		RESISTOR 10K 1% .125W F TC=0+-100	24546	C4-1/8-T0-1002-F
A13R22	0757-0442	9		RESISTOR 10K 1% .125W F TC=0+-100	24546	C4-1/8-T0-1002-F
A13R23*	0757-0288	1	2	RESISTOR 9.09K 1% .125W F TC=0+-100	19701	MF4C1/8-T0-9091-F
A13R24	0757-0465	6	2	RESISTOR 100K 1% .125W F TC=0+-100	24546	C4-1/8-T0-1003-F
A13R25	0757-0465	6		RESISTOR 100K 1% .125W F TC=0+-100	24546	C4-1/8-T0-1003-F
A13R26	2100-3163	8	1	RESISTOR-TRMR 1M 20% C SIDE-ADJ 17-TRN	02111	43P105
A13R27	0757-0444	1		RESISTOR 12.1K 1% .125W F TC=0+-100	24546	C4-1/8-T0-1212-F
A13R28	0757-0443	0	2	RESISTOR 11K 1% .125W F TC=0+-100	24546	C4-1/8-T0-1102-F
A13R29	0698-0083	8	2	RESISTOR 1.96K 1% .125W F TC=0+-100	24546	C4-1/8-T0-1961-F
A13R30	0757-0402	1		RESISTOR 110 1% .125W F TC=0+-100	24546	C4-1/8-T0-111-F
A13R31	2100-3052	4	1	RESISTOR-TRMR 50 10% C SIDE-ADJ 17-TRN	02111	43P500
A13R32*	0698-3454	3	1	RESISTOR 215K 1% .125W F TC=0+-100	24546	C4-1/8-T0-2153-F
A13R33	0757-0442	9		RESISTOR 10K 1% .125W F TC=0+-100	24546	C4-1/8-T0-1002-F
A13R34	0757-0159	3	1	RESISTOR 21.5K 1% .125W F TC=0+-100	24546	C4-1/8-T0-2153-F
A13R35	0757-0288	1		RESISTOR 9.09K 1% .125W F TC=0+-100	19701	MF4C1/8-T0-9091-F
A13R36	0698-0083	8		RESISTOR 1.96K 1% .125W F TC=0+-100	24546	C4-1/8-T0-1961-F
A13R37	0757-0416	7	2	RESISTOR 511 1% .125W F TC=0+-100	24546	C4-1/8-T0-511R-F
A13R38	0698-3441	8	1	RESISTOR 215 1% .125W F TC=0+-100	24546	C4-1/8-T0-215R-F
A13R39	0757-0419	0		RESISTOR 691 1% .125W F TC=0+-100	24546	C4-1/8-T0-681R-F
A13R40	0698-3442	9		RESISTOR 237 1% .125W F TC=0+-100	24546	C4-1/8-T0-237R-F
A13R41	0698-3154	0		RESISTOR 4.22K 1% .125W F TC=0+-100	24546	C4-1/8-T0-4221-F
A13R42	0757-0442	9		RESISTOR 10K 1% .125W F TC=0+-100	24546	C4-1/8-T0-1002-F
A13R43*	0698-3155	1		RESISTOR 4.64K 1% .125W F TC=0+-100	24546	C4-1/8-T0-4641-F
A13R44	0757-0442	9		RESISTOR 10K 1% .125W F TC=0+-100	24546	C4-1/8-T0-1002-F
A13R45	0757-0461	0		RESISTOR 100 1% .125W F TC=0+-100	24546	C4-1/8-T0-101-F
A13R46	0757-0401	0		RESISTOR 100 1% .125W F TC=0+-100	24546	C4-1/8-T0-101-F
A13R47	0757-0346	2		RESISTOR 10 1% .125W F TC=0+-100	24546	C4-1/8-T0-10R0-F
A13R48*	0757-0444	1	4	RESISTOR 12.1K 1% .125W F TC=0+-100	24546	C4-1/8-T0-1212-F
A13R49	0757-0444	1		RESISTOR 12.1K 1% .125W F TC=0+-100	24546	C4-1/8-T0-1212-F
A13R50	0757-0346	2		RESISTOR 10 1% .125W F TC=0+-100	24546	C4-1/8-T0-10R0-F
A13R51	0757-0346	2		RESISTOR 10 1% .125W F TC=0+-100	24546	C4-1/8-T0-10R0-F
A13R52	0757-0443	0		RESISTOR 11K 1% .125W F TC=0+-100	24546	C4-1/8-T0-1102-F
A13R53	0698-3440	7		RESISTOR 196 1% .125W F TC=0+-100	24546	C4-1/8-T0-196R-F
A13R54	0757-0416	7		RESISTOR 511 1% .125W F TC=0+-100	24546	C4-1/8-T0-511R-F
A13R55	0757-0442	9		RESISTOR 10K 1% .125W F TC=0+-100	24546	C4-1/8-T0-1002-F
A13R56*	0757-0274	5	1	RESISTOR 1.21K 1% .125W F TC=0+-100	24546	C4-1/8-T0-1211-F
A13R57	0757-0180	2	2	RESISTOR 31.6 1% .125W F TC=0+-100	28480	0757-0180
A13R58	0698-3152	8	1	RESISTOR 3.48K 1% .125W F TC=0+-100	24546	C4-1/8-T0-3481-F
A13R59	0757-0180	2	2	RESISTOR 31.6 1% .125W F TC=0+-100	28480	0757-0180
A13R60	0698-3153	9	1	RESISTOR 3.83K 1% .125W F TC=0+-100	24546	C4-1/8-T0-3831-F
A13TP1	0360-1788	7	4	CONNECTOR-SGL CONT PIN .045-IN-BSC-SZ SQ	28480	0360-1788
A13TP2	0360-1788	7		CONNECTOR-SGL CONT PIN .045-IN-BSC-SZ SQ	28480	0360-1788
A13TP3	1251-0600	0	2	CONNECTOR-SGL CONT PIN 1.14-MM-BSC-SZ SQ	28480	1251-0600
A13TP6	1251-0600	0		CONNECTOR-SGL CONT PIN 1.14-MM-BSC-SZ SQ	28480	1251-0600
A13VR1	1902-0048	1	1	DIODE-ZNR 6.81V 5% DO-35 PD=.4W	28480	1902-0048
A13Y1	0410-0776	8	2	CRYSTAL-QUARTZ 21.4 MHZ HC-25/U-HLDR SET OF 4 INCLUDES A11Y1,Y2 AND A13Y1,Y2	28480	0410-0776
A13Y2	0410-0776	8		CRYSTAL-QUARTZ 21.4 MHZ HC-25/U-HLDR SET OF 4 INCLUDES A11Y1,Y2 AND A13Y1,Y2	28480	0410-0776
				MISCELLANEOUS		
	0403-0026	6	1	PLUG-HOLE BDR-HD FOR .187-D-HOLE NYL	02768	207-126241-03-0101
	08559-00025	5	1	BAFFLE INDUCTOR	28480	08559-00025

*Indicates factory selected value

**A13
BANDWIDTH FILTER NO. 2 ASSEMBLY
08559-60058**

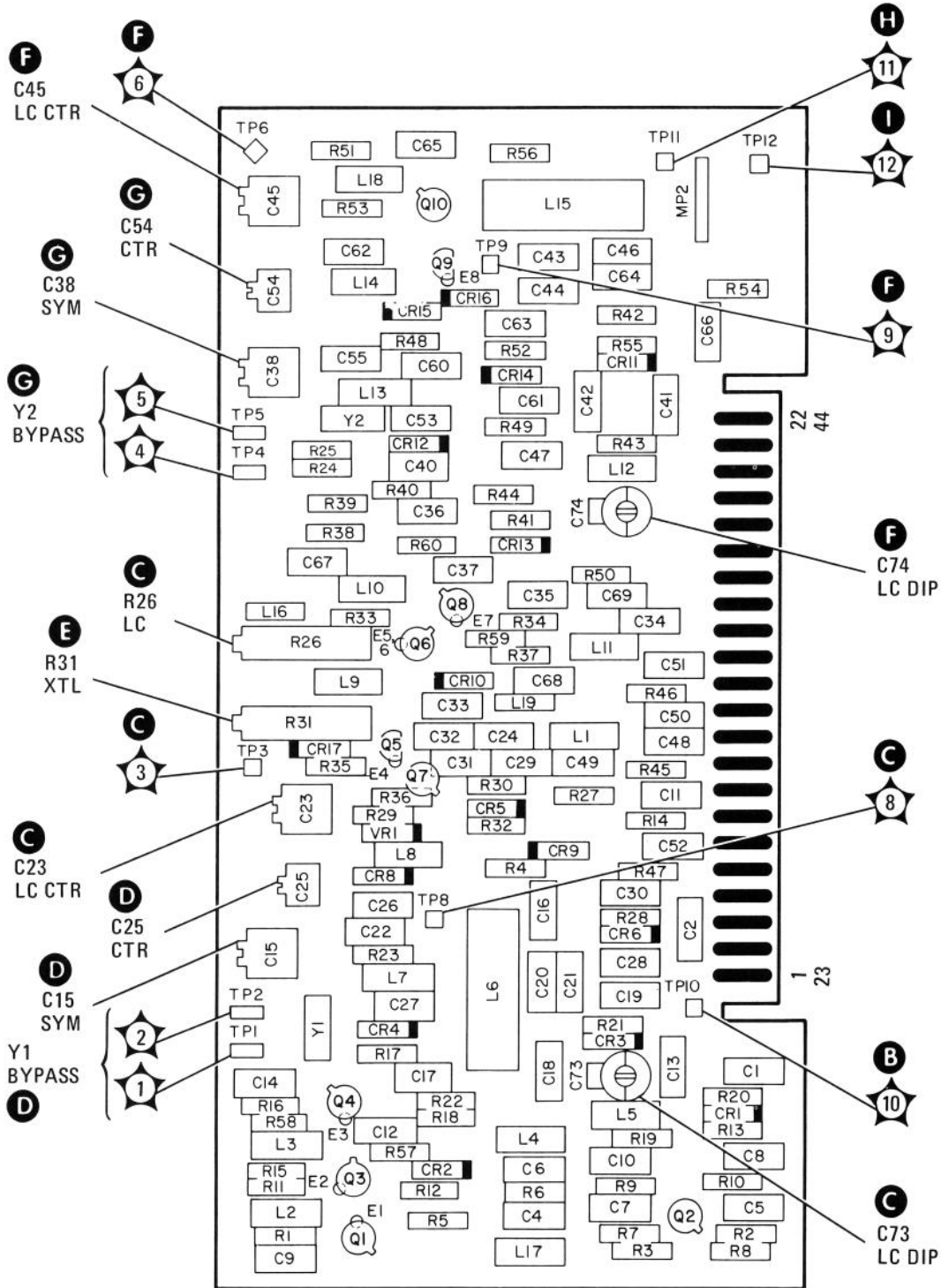

FIGURE 8-48. A13 BANDWIDTH FILTER NO. 2 ASSEMBLY, COMPONENT LOCATIONS

A14 LOG AMPLIFIER ASSEMBLY, CIRCUIT DESCRIPTION

The Log Amplifier Assembly A14 includes seven amplifier stages, each capable of providing linear and logarithmic amplification. A detector circuit following the amplifier stages detects the amplified 21.4 MHz IF signal, producing the vertical display signal. The offset circuit that follows the detector operates in Log mode to offset the vertical display signal in 100 mV steps. This steps the display in four 10-dB increments of apparent gain and adds the last 40 dB of displayed step gain to the gain (50 dB) already provided in the IF section.

Amplifier Stages (1st through 7th) (A) (C) (D) (E) (F) (G) (H)

The seven amplifier stages are similar in operation. Different stages are selected as linear or log amplifiers, depending on the setting of the Amplitude Scale switch.

Log Mode of Operation: In Log mode, the gain of the seven amplifier stages is sequentially limited as the signal level increases. Limiting starts with stage seven, since it sees the combined gains of the other stages, and continues sequentially as the signal level increases. Stage one is the last stage to begin limiting the signal. The total limiting process provides 70 dB of log display range. Each stage consists of an emitter follower voltage-driver and a common-base amplifier in which the gain is signal-level dependent. Increases in signal level decrease the gain.

A simplified schematic of a typical log stage (the second stage) is shown in Figure 8-50. In Log mode, the LOG/LIN control line is high (about +15V); Q24 is on, forward biasing diodes CR10 and CR11 and the log diodes in all of the other stages. Diodes CR10 and CR11 are Schottky diodes with a forward bias voltage of approximately 0.4V. Emitter follower Q13 is a voltage source that develops signal current flow through CR10 and CR11. This signal current drives Q20, a common-base amplifier tuned to approximately 21.4 MHz. The gain of this amplifier is set by the ratio of R52 to the total resistance, R_T , between the emitters of Q13 and Q20 (primarily the resistance of CR10 and CR11). The formula for computing the gain in dB is:

$$\text{Gain (dB)} = 20\text{LOG}(1 + R52/R_T)$$

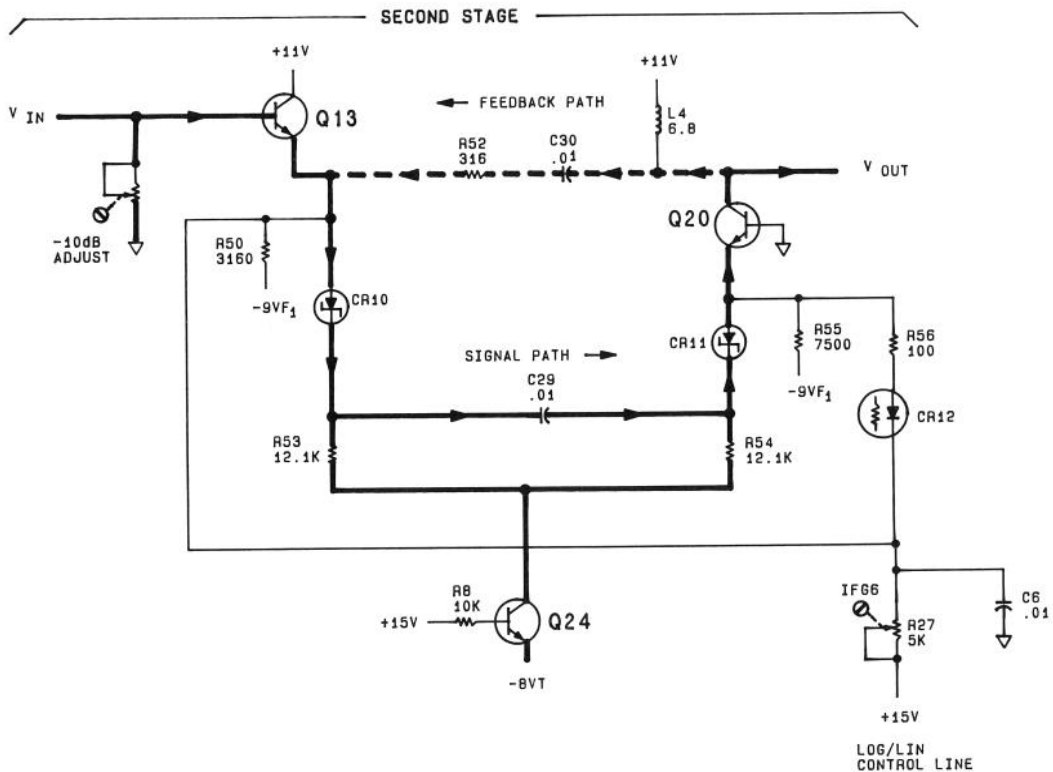

FIGURE 8-50. LOG MODE OPERATION, SIMPLIFIED SCHEMATIC

Resistance R_T is at a minimum (approximately 150 ohms) for small signals. The small signal gain of the stage (about 10 dB) is established by the dc bias through the log diodes. As the signal level at the emitter of Q13 increases, signal current cancels bias current in the log diodes, increasing R_T . The gain of the stage for large signals is reduced to unity (0 dB) as R_T becomes very large.

Linear Mode of Operation: Two simplified schematics illustrating unity and 10 dB gain of a typical linear stage are shown in Figures 8-51 and 8-52. In linear mode, the signal-level dependent components are removed from the signal path and a linear display is provided. The -8VT is applied to the base of Q24, turning it off. This removes dc bias from CR10 and CR11. Total resistance R_T (primarily the resistance of R56 and CR12) is high, since CR12 is reverse-biased. Control line IFG6 is high and the stage gain is near unity. The signal flow is through emitter follower Q13 and R52, to Q20. In stages six and seven, an alternate signal path is used to fix the gain at about 5 dB per stage, allowing for scale differences between Log and Lin modes. Both stages are activated by the -8VT from the Amplitude Scale switch through R34, R93, R101, CR25, and CR28. The combined stage gain is adjusted by R34 (LIN), which controls the dc PIN diode bias.

Stages 2, 3, 4, and 5 each have an alternate signal path that switches in 10 dB of step gain for a total of 40 dB. The alternate path is selected by the REFERENCE LEVEL control. With the INPUT ATTEN at 0 dB and the REFERENCE LEVEL control at -60 dBm, the -8VT is routed, via the IF gain control line (IFG4), to forward bias CR22 in stage 5. For each stepped increase in the REFERENCE LEVEL control, the -8VT activates the IFG lines associated with the stages of gain required, forward biasing the diodes in the signal path. Each IFG line has a potentiometer (block **(B)**) that controls the line's bias current and the stage gain. Note that IFG6 controls two stages (stages 2 and 3) that, when switched in, provide 20 dB of gain.

Gain Control Lines (B)

The $+15\text{V}$ (in Log mode) or the -8VT (in Lin mode) is routed through the REFERENCE LEVEL switch to the combination of IFG4, IFG5, and IFG6 corresponding to the reference level selected. In Log mode, the Log Offset circuit is activated through R24, R25, and R26. The LOG/LIN line is at $+15\text{V}$, Q24 is saturated, and the collector of Q24 goes to -8VT , turning the log diodes on. In Lin mode, the LOG/LIN line is at -8VT , Q24 is turned off and current flows through R34 (LIN) to stages 6 and 7.

Log Mode Temperature-Controlled Variable-Gain Amplifier (J)

In Lin mode, when approximately 700 mV rms ($+10$ dBm) is applied to the input of the Log amplifier, the voltage at the output of stage 7 (TP5) is about 1.5V rms. With the same input in Log mode, the output at TP5 is about 2.0V rms. To maintain an equal relationship with maximum input signal (the trace at top display), the output in Log mode must be attenuated. This attenuation is achieved with variable gain amplifier Q7, the gain of which is determined by the ratio of its collector load to its emitter load.

In Lin mode, the LOG/LIN line is at -8VT , CR4 is forward biased, and the output of U2B (TP1) is approximately $+15\text{V}$. Diode CR29 is reverse biased and the gain of the variable gain amplifier is R104/R105 (100/316) or approximately 0.3. In Log mode, the LOG/LIN line is at $+15\text{V}$, CR4 is reverse biased, and the output of U2B (TP1) is about -0.45V . Diode CR29 is forward biased and exhibits an ac resistance of about 100 ohms. This resistance is in parallel with the 100 ohms of R104 for a total of 50 ohms. Since the collector load of Q7 is about 50 ohms, the gain becomes 0.15 (50/316). This gain depends upon the resistance of CR29, which is established by SLOPE adjustment R23.

Detector (K)

The detector comprises a voltage-to-current converter, a half-wave rectifier, and a low-pass filter. The output of the variable gain amplifier is applied to Q6, where voltage variations are converted to current variations. Transistor Q5 acts as a current driver for half-wave rectifier Q4, while CR1 biases Q4 just below cutoff. When the signal is positive going, Q4 conducts; during the negative half-cycle, Q4 is cut off. The detector's output goes to the low-pass filter, a series of pi-section filters that smooth the detector's output and remove RF signal components.

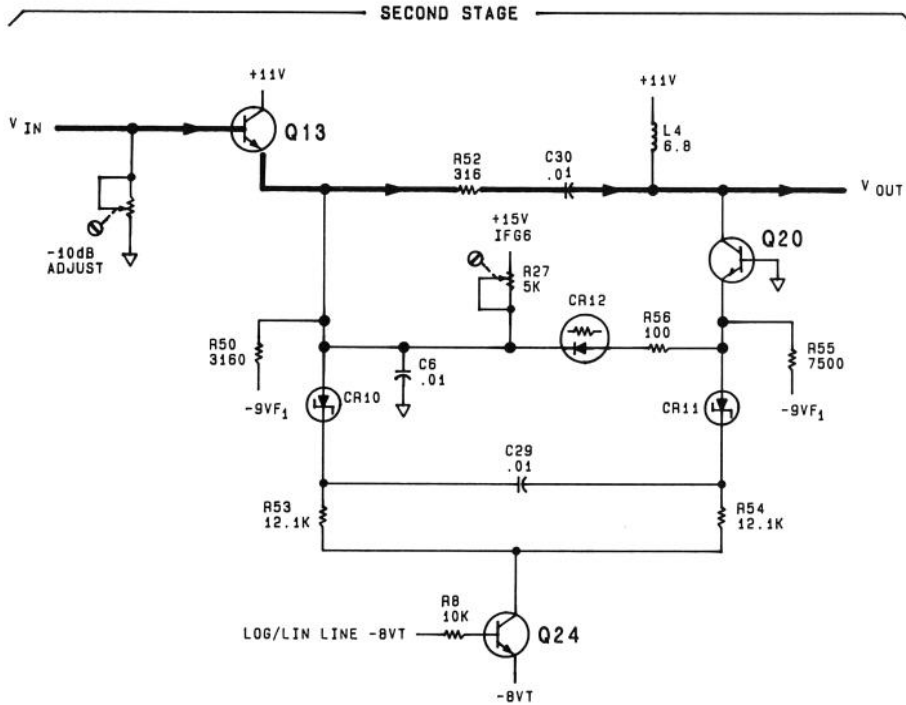

FIGURE 8-51. UNITY GAIN OPERATION IN LINEAR MODE, SIMPLIFIED SCHEMATIC

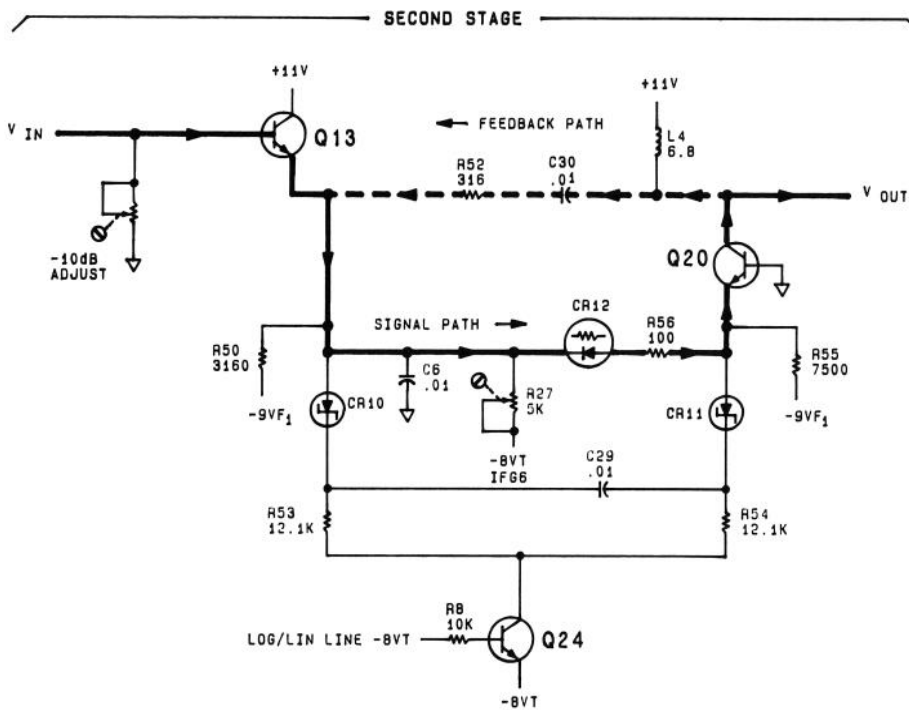

FIGURE 8-52. 10 dB GAIN OPERATION IN LINEAR MODE, SIMPLIFIED SCHEMATIC

Buffer Amplifier (L)

The detector's output, the video signal, is amplified by the Buffer Amplifier. Differential pair Q21 and driver Q22 approximate a noninverting operational amplifier with a gain calculated by the formula:

$$\text{Gain} = 1 + R110/R116$$

Which becomes: $1 + 619/619 = 2$

Log Offset (M)

The offset circuit operates in Log mode to offset the video signal in four 100 mV steps. These appear on the display as 10 dB steps of apparent gain. This gain adds the last 40 dB of display step gain to the 50 dB of gain already provided by the Step Gain Assembly A12. The offset is provided by Q23 operating as a current source that steps the current through R119. When the Log mode is selected, +15V via the REFERENCE LEVEL switch can be applied to IF gain control lines IFG4, IFG5, and IFG6. When an IFG line is activated, the associated log-shift diode (CR31, CR32, or CR33) is forward biased, causing current (determined by R123, R124, or R125) to flow in Q23. Each IFG line supplies a specific offset when activated; IFG4 and IFG5 each provide 100 mV, while IFG6 provides 200 mV. The LOG GAIN adjustment (R121) establishes the operating point of Q23 as needed for 100 mV steps.

Temperature Compensation Power Supply (I)

Temperature compensating of the Log Amplifier Assembly A14 is provided by the -8VT (both VT and VTV mean Volts Temperature Variable) and -1VTV regulators while CR2 operates as the temperature-sensing element. Temperature variations cause diode voltage changes that, when amplified by U1A, regulate the -8VT supply. Since the -1VTV supply is coupled to the -8VT supply through R17 and R132, its output is also temperature variable. The -8VT provides bias for the log diodes in Log mode and bias current for CR12, CR19, CR22, and CR28 in Lin mode. The -1VTV supplies bias to CR29 in the variable gain amplifier.

+11V Regulated Power Supply (N)

A precise +5.4V reference for the +11V regulator is provided by VR1. This reference voltage is applied to the noninverting input of U1B. Since the ratio of R5 to R6 establishes the gain of U1B at 2.1, the output at TP2 is 2.1 times +5.4. (+11.3V). Emitter follower Q1 provides current drive for the +11V supply.

A14 LOG AMPLIFIER ASSEMBLY, TROUBLESHOOTING

Check supply voltages.

Dead Stage: Use an oscilloscope along the signal path to locate a dead stage.

Check the dc levels along the signal path. Beginning after stage two, the dc level alternates between -0.7V and 0V with each successive stage because of the direct coupling of the stages. This is noted in the waveforms indicated on the schematic.

Log Fidelity Accuracy: Begin testing by establishing a top graticule reference (eighth graticule). Reduce the input signal level in 10 dB steps and observe the variations between each step. Now, establish a reference at the next graticule 100 mV lower (seventh graticule). Step the signal level again and observe the variation between the steps. Continue lowering the reference point until each step below the reference point is within specification. This will indicate at which step the inaccuracies are being introduced. If the error occurs between the 800 mV reference and the 700 mV reference, the problem is probably in the first stage. If the problem is present at all reference levels except the last one, the problem is probably in the last amplifier stage, since it compresses first.

The most probable causes of failure are PIN diodes, Schottky diodes, transistors, capacitors, and resistors, in that order.

Schottky diodes have a dc resistance of about 300 to 330 ohms. The value varies depending on the current supplied by the ohmmeter. The values should, however, all be within 10% of each other.

TABLE 8-14. A14 LOG AMPLIFIER ASSEMBLY, REPLACEABLE PARTS (1 OF 5)

Reference Designation	HP Part Number	C D	Qty	Description	Mfr Code	Mfr Part Number
A14	5061-5411	2	1	LOG AMPLIFIER ASSEMBLY	28480	5061-5411
A14C1	0160-4554	7	67	CAPACITOR-FXD .01UF +-20% 50VDC CER	28480	0160-4554
A14C2	0180-0197	8	1	CAPACITOR-FXD 2.2UF +-10% 20VDC TA	55289	1500225X9020A2
A14C3	0160-4554	7		CAPACITOR-FXD .01UF +-20% 50VDC CER	28480	0160-4554
A14C4	0160-4084	8	2	CAPACITOR-FXD .1UF +-20% 50VDC CER	28480	0160-4084
A14C5	0160-4084	8		CAPACITOR-FXD .1UF +-20% 50VDC CER	28480	0160-4084
A14C6	0160-4554	7		CAPACITOR-FXD .01UF +-20% 50VDC CER	28480	0160-4554
A14C7	0160-3879	7	1	CAPACITOR-FXD .01UF +-20% 100VDC CER	28480	0160-3879
A14C8	0160-4554	7		CAPACITOR-FXD .01UF +-20% 50VDC CER	28480	0160-4554
A14C9	0160-4554	7		CAPACITOR-FXD .01UF +-20% 50VDC CER	28480	0160-4554
A14C10	0160-4554	7		CAPACITOR-FXD .01UF +-20% 50VDC CER	28480	0160-4554
A14C11	0160-4554	7		CAPACITOR-FXD .01UF +-20% 50VDC CER	28480	0160-4554
A14C12	0160-4554	7		CAPACITOR-FXD .01UF +-20% 50VDC CER	28480	0160-4554
A14C13				NOT ASSIGNED		
A14C14	0160-4554	7		CAPACITOR-FXD .01UF +-20% 50VDC CER	28480	0160-4554
A14C15	0160-4554	7		CAPACITOR-FXD .01UF +-20% 50VDC CER	28480	0160-4554
A14C16	0160-4554	7		CAPACITOR-FXD .01UF +-20% 50VDC CER	28480	0160-4554
A14C17	0160-4554	7		CAPACITOR-FXD .01UF +-20% 50VDC CER	28480	0160-4554
A14C18	0160-4554	7		CAPACITOR-FXD .01UF +-20% 50VDC CER	28480	0160-4554
A14C19	0160-4554	7		CAPACITOR-FXD .01UF +-20% 50VDC CER	28480	0160-4554
A14C20	0160-4554	7		CAPACITOR-FXD .01UF +-20% 50VDC CER	28480	0160-4554
A14C21	0160-4554	7		CAPACITOR-FXD .01UF +-20% 50VDC CER	28480	0160-4554
A14C22	0160-4554	7		CAPACITOR-FXD .01UF +-20% 50VDC CER	28480	0160-4554
A14C23	0160-4554	7		CAPACITOR-FXD .01UF +-20% 50VDC CER	28480	0160-4554
A14C24	0160-4554	7		CAPACITOR-FXD .01UF +-20% 50VDC CER	28480	0160-4554
A14C25	0160-4554	7		CAPACITOR-FXD .01UF +-20% 50VDC CER	28480	0160-4554
A14C26	0160-4554	7		CAPACITOR-FXD .01UF +-20% 50VDC CER	28480	0160-4554
A14C27	0160-4554	7		CAPACITOR-FXD .01UF +-20% 50VDC CER	28480	0160-4554
A14C28	0160-4554	7		CAPACITOR-FXD .01UF +-20% 50VDC CER	28480	0160-4554
A14C29	0160-4554	7		CAPACITOR-FXD .01UF +-20% 50VDC CER	28480	0160-4554
A14C30	0160-4554	7		CAPACITOR-FXD .01UF +-20% 50VDC CER	28480	0160-4554
A14C31	0160-4554	7		CAPACITOR-FXD .01UF +-20% 50VDC CER	28480	0160-4554
A14C32	0160-4554	7		CAPACITOR-FXD .01UF +-20% 50VDC CER	28480	0160-4554
A14C33	0160-4554	7		CAPACITOR-FXD .01UF +-20% 50VDC CER	28480	0160-4554
A14C34	0160-4554	7		CAPACITOR-FXD .01UF +-20% 50VDC CER	28480	0160-4554
A14C35				NOT ASSIGNED		
A14C36	0160-4554	7		CAPACITOR-FXD .01UF +-20% 50VDC CER	28480	0160-4554
A14C37	0160-4554	7		CAPACITOR-FXD .01UF +-20% 50VDC CER	28480	0160-4554
A14C38	0160-4554	7		CAPACITOR-FXD .01UF +-20% 50VDC CER	28480	0160-4554
A14C39	0160-4554	7		CAPACITOR-FXD .01UF +-20% 50VDC CER	28480	0160-4554
A14C40	0160-4554	7		CAPACITOR-FXD .01UF +-20% 50VDC CER	28480	0160-4554
A14C41	0160-4554	7		CAPACITOR-FXD .01UF +-20% 50VDC CER	28480	0160-4554
A14C42	0160-4554	7		CAPACITOR-FXD .01UF +-20% 50VDC CER	28480	0160-4554
A14C43	0160-4554	7		CAPACITOR-FXD .01UF +-20% 50VDC CER	28480	0160-4554
A14C44	0160-4554	7		CAPACITOR-FXD .01UF +-20% 50VDC CER	28480	0160-4554
A14C45	0160-4554	7		CAPACITOR-FXD .01UF +-20% 50VDC CER	28480	0160-4554
A14C46	0160-4554	7		CAPACITOR-FXD .01UF +-20% 50VDC CER	28480	0160-4554
A14C47	0160-4554	7		CAPACITOR-FXD .01UF +-20% 50VDC CER	28480	0160-4554
A14C48	0160-4554	7		CAPACITOR-FXD .01UF +-20% 50VDC CER	28480	0160-4554
A14C49	0160-4554	7		CAPACITOR-FXD .01UF +-20% 50VDC CER	28480	0160-4554
A14C50	0160-4554	7		CAPACITOR-FXD .01UF +-20% 50VDC CER	28480	0160-4554
A14C51	0160-4554	7		CAPACITOR-FXD .01UF +-20% 50VDC CER	28480	0160-4554
A14C52	0160-4554	7		CAPACITOR-FXD .01UF +-20% 50VDC CER	28480	0160-4554
A14C53	0160-4554	7		CAPACITOR-FXD .01UF +-20% 50VDC CER	28480	0160-4554
A14C54	0160-4554	7		CAPACITOR-FXD .01UF +-20% 50VDC CER	28480	0160-4554
A14C55	0160-4554	7		CAPACITOR-FXD .01UF +-20% 50VDC CER	28480	0160-4554
A14C56	0160-4554	7		CAPACITOR-FXD .01UF +-20% 50VDC CER	28480	0160-4554
A14C57	0160-4554	7		CAPACITOR-FXD .01UF +-20% 50VDC CER	28480	0160-4554
A14C58	0160-4554	7		CAPACITOR-FXD .01UF +-20% 50VDC CER	28480	0160-4554
A14C59	0160-4554	7		CAPACITOR-FXD .01UF +-20% 50VDC CER	28480	0160-4554
A14C60	0160-4554	7		CAPACITOR-FXD .01UF +-20% 50VDC CER	28480	0160-4554
A14C61	0160-4554	7		CAPACITOR-FXD .01UF +-20% 50VDC CER	28480	0160-4554
A14C62	0160-4554	7		CAPACITOR-FXD .01UF +-20% 50VDC CER	28480	0160-4554
A14C63	0160-4554	7		CAPACITOR-FXD .01UF +-20% 50VDC CER	28480	0160-4554
A14C64	0160-4554	7		CAPACITOR-FXD .01UF +-20% 50VDC CER	28480	0160-4554
A14C65	0160-4554	7		CAPACITOR-FXD .01UF +-20% 50VDC CER	28480	0160-4554
A14C66	0160-4554	7		CAPACITOR-FXD .01UF +-20% 50VDC CER	28480	0160-4554
A14C67	0160-4554	7		CAPACITOR-FXD .01UF +-20% 50VDC CER	28480	0160-4554
A14C68	0160-4554	7		CAPACITOR-FXD .01UF +-20% 50VDC CER	28480	0160-4554
A14C69	0160-4554	7		CAPACITOR-FXD .01UF +-20% 50VDC CER	28480	0160-4554
A14C70	0160-4519	4	1	CAPACITOR-FXD 9.1PF +- .5PF 200VDC CER	28480	0160-4519

*Indicates factory selected value

TABLE 8-14. A14 LOG AMPLIFIER ASSEMBLY, REPLACEABLE PARTS (2 OF 5)

Reference Designation	HP Part Number	C D	Qty	Description	Mfr Code	Mfr Part Number
A14C71	0140-0195	2	1	CAPACITOR-FXD 130PF +-5% 300VDC MICA	72136	DM15F131J0300WV1CR
A14C72	0160-4386	3	1	CAPACITOR-FXD 33PF +-5% 200VDC CER 04-30	28480	0160-4386
A14C73	0160-3872	0	1	CAPACITOR-FXD 2.2PF +- .25PF 200VDC CER	28480	0160-3872
A14C74	0160-4554	7		CAPACITOR-FXD .01UF +-20% 50VDC CER	28480	0160-4554
A14C75	0160-4554	7		CAPACITOR-FXD .01UF +-20% 50VDC CER	28480	0160-4554
A14C76	0160-4554	7		CAPACITOR-FXD .01UF +-20% 50VDC CER	28480	0160-4554
A14C77	0160-4554	7		CAPACITOR-FXD .01UF +-20% 50VDC CER	28480	0160-4554
A14CR1	1901-0016	0	1	DIODE-GE 60V 60MA 1US DO-7	28480	1901-0016
A14CR2	1901-0050	3	5	DIODE-SWITCHING 80V 200MA 2NS DO-35	28480	1901-0050
A14CR4	1901-0050	3		DIODE-SWITCHING 80V 200MA 2NS DO-35	28480	1901-0050
A14CR6	1901-1085	6	17	DIODE-SM SIG SCHOTTKY	28480	1901-1085
A14CR7	1901-1085	6		DIODE-SM SIG SCHOTTKY	28480	1901-1085
A14CR8	1901-1085	6		DIODE-SM SIG SCHOTTKY	28480	1901-1085
A14CR9	1901-1085	6		DIODE-SM SIG SCHOTTKY	28480	1901-1085
A14CR10	1901-1085	6		DIODE-SM SIG SCHOTTKY	28480	1901-1085
A14CR11	1901-1085	6		DIODE-SM SIG SCHOTTKY	28480	1901-1085
A14CR12	1901-1070	9	7	DIODE-PIN 110V	28480	1901-1070
A14CR13	1901-1085	6		DIODE-SM SIG SCHOTTKY	28480	1901-1085
A14CR14	1901-1085	6		DIODE-SM SIG SCHOTTKY	28480	1901-1085
A14CR15	1901-1070	9		DIODE-PIN 110V	28480	1901-1070
A14CR16	1901-1070	9		DIODE-PIN 110V	28480	1901-1070
A14CR17	1901-1085	6		DIODE-SM SIG SCHOTTKY	28480	1901-1085
A14CR18	1901-1085	6		DIODE-SM SIG SCHOTTKY	28480	1901-1085
A14CR19	1901-1070	9		DIODE-PIN 110V	28480	1901-1070
A14CR20	1901-1085	6		DIODE-SM SIG SCHOTTKY	28480	1901-1085
A14CR21	1901-1085	6		DIODE-SM SIG SCHOTTKY	28480	1901-1085
A14CR22	1901-0040	1	1	DIODE-SWITCHING 30V 50MA 2NS DO-35	28480	1901-0040
A14CR23	1901-1085	6		DIODE-SM SIG SCHOTTKY	28480	1901-1085
A14CR24	1901-1085	6		DIODE-SM SIG SCHOTTKY	28480	1901-1085
A14CR25	1901-1070	9		DIODE-PIN 110V	28480	1901-1070
A14CR26	1901-1085	6		DIODE-SM SIG SCHOTTKY	28480	1901-1085
A14CR27	1901-1085	6		DIODE-SM SIG SCHOTTKY	28480	1901-1085
A14CR28	1901-1070	9		DIODE-PIN 110V	28480	1901-1070
A14CR29	1901-1070	9		DIODE-PIN 110V	28480	1901-1070
A14CR30	1901-1085	6		DIODE-SM SIG SCHOTTKY	28480	1901-1085
A14CR31	1901-0050	3		DIODE-SWITCHING 80V 200MA 2NS DO-35	28480	1901-0050
A14CR32	1901-0050	3		DIODE-SWITCHING 80V 200MA 2NS DO-35	28480	1901-0050
A14CR33	1901-0050	3		DIODE-SWITCHING 80V 200MA 2NS DO-35	28480	1901-0050
A14E1	9170-0029	3	1	CORE-SHIELDING BEAD	28480	9170-0029
A14L1	9100-1610	1	1	INDUCTOR RF-CH-MLD 5.6UH 10%	28480	9100-1610
A14L2	9140-0144	0	1	INDUCTOR RF-CH-MLD 4.7UH 10% .135DX.26LG	28480	9140-0144
A14L3	9140-0105	3	2	INDUCTOR RF-CH-MLD 8.2UH 10%	28480	9140-0105
A14L4	9100-1619	2	2	INDUCTOR RF-CH-MLD 6.8UH 10%	28480	9100-1619
A14L5	9100-1619	2		INDUCTOR RF-CH-MLD 6.8UH 10%	28480	9100-1619
A14L6	9140-0114	4	3	INDUCTOR RF-CH-MLD 10UH 10% .166DX.355LG	28480	9140-0114
A14L7	9140-0114	4		INDUCTOR RF-CH-MLD 10UH 10% .166DX.355LG	28480	9140-0114
A14L8	9140-0114	4		INDUCTOR RF-CH-MLD 10UH 10% .166DX.355LG	28480	9140-0114
A14L9	9140-0112	2	1	INDUCTOR RF-CH-MLD 4.7UH 10%	28480	9140-0112
A14L10	9140-0105	3		INDUCTOR RF-CH-MLD 8.2UH 10%	28480	9140-0105
A14L11	9100-1627	2	1	INDUCTOR RF-CH-MLD 39UH 5% .166DX.385LG	28480	9100-1627
A14L12	9100-1629	4	1	INDUCTOR RF-CH-MLD 47UH 5% .166DX.385LG	28480	9100-1629
A14L13	9100-1622	7	1	INDUCTOR RF-CH-MLD 24UH 5% .166DX.385LG	28480	9100-1622
A14L14	9100-2257	6	1	INDUCTOR RF-CH-MLD 820MH 10% .105DX.26LG	28480	9100-2257
A14Q1	1854-0637	1	1	TRANSISTOR NPN 2N2219A SI TO-5 PD=800MW	01275	2N2219A
A14Q2	1853-0281	9	3	TRANSISTOR PNP 2N2907A SI TO-18 PD=400MW	04713	2N2907A
A14Q3	1853-0281	9		TRANSISTOR PNP 2N2907A SI TO-18 PD=400MW	04713	2N2907A
A14Q4	1853-0015	7	5	TRANSISTOR PNP SI PD=200MW FT=500MHZ	28480	1853-0015
A14Q5	1853-0015	7		TRANSISTOR PNP SI PD=200MW FT=500MHZ	28480	1853-0015
A14Q6	1853-0007	7	1	TRANSISTOR PNP 2N3251 SI TO-18 PD=360MW	04713	2N3251
A14Q7	1854-0019	3	12	TRANSISTOR NPN SI TO-18 PD=360MW	28480	1854-0019
A14Q8	1853-0015	7		TRANSISTOR PNP SI PD=200MW FT=500MHZ	28480	1853-0015
A14Q9	1854-0019	3		TRANSISTOR NPN SI TO-18 PD=360MW	28480	1854-0019
A14Q10	1853-0015	7		TRANSISTOR PNP SI PD=200MW FT=500MHZ	28480	1853-0015
A14Q11	1854-0019	3		TRANSISTOR NPN SI TO-18 PD=360MW	28480	1854-0019
A14Q12	1853-0015	7		TRANSISTOR PNP SI PD=200MW FT=500MHZ	28480	1853-0015
A14Q13	1854-0019	3		TRANSISTOR NPN SI TO-18 PD=360MW	28480	1854-0019
A14Q14	1854-0019	3		TRANSISTOR NPN SI TO-18 PD=360MW	28480	1854-0019
A14Q15	1854-0019	3		TRANSISTOR NPN SI TO-18 PD=360MW	28480	1854-0019
A14Q16	1854-0019	3		TRANSISTOR NPN SI TO-18 PD=360MW	28480	1854-0019
A14Q17	1854-0019	3		TRANSISTOR NPN SI TO-18 PD=360MW	28480	1854-0019
A14Q18	1854-0019	3		TRANSISTOR NPN SI TO-18 PD=360MW	28480	1854-0019
A14Q19	1854-0019	3		TRANSISTOR NPN SI TO-18 PD=360MW	28480	1854-0019
A14Q20	1854-0019	3		TRANSISTOR NPN SI TO-18 PD=360MW	28480	1854-0019

*Indicates factory selected value

TABLE 8-14. A14 LOG AMPLIFIER ASSEMBLY, REPLACEABLE PARTS (3 OF 5)

Reference Designation	HP Part Number	C D	Qty	Description	Mfr Code	Mfr Part Number
A14Q21	1854-0475	5	1	TRANSISTOR-DUAL NPN PD=750MW	28480	1854-0475
A14Q22	1854-0464	0	2	TRANSISTOR NPN SI TO-18 PD=360MW	28480	1854-0464
A14Q23	1853-3281	7		TRANSISTOR PNP 2N2937A SI TO-18 PD=400MW	34713	2N2937A
A14Q24	1854-0464	0		TRANSISTOR NPN SI TO-18 PD=360MW	28480	1854-0464
A14Q25	1854-0019	3		TRANSISTOR NPN SI TO-18 PD=360MW	28480	1854-0019
A14R1	0757-0317	7	1	RESISTOR 1.33K 1% .125W F TC=0+-100	24546	C4-1/8-T0-1331-F
A14R2	0757-0280	3	8	RESISTOR 1K 1% .125W F TC=0+-100	24546	C4-1/8-T0-1001-F
A14R3	0698-0084	9	1	RESISTOR 2.15K 1% .125W F TC=0+-100	24546	C4-1/8-T0-2151-F
A14R4	0698-3430	5	1	RESISTOR 21.5 1% .125W F TC=0+-100	03888	PME55-1/8-T0-21R5-F
A14R5	0757-0443	0	1	RESISTOR 11K 1% .125W F TC=0+-100	24546	C4-1/8-T0-1102-F
A14R6	0757-0442	9	4	RESISTOR 18K 1% .125W F TC=0+-100	24546	C4-1/8-T0-1802-F
A14R7	0757-0465	6	4	RESISTOR 100K 1% .125W F TC=0+-100	24546	C4-1/8-T0-1001-F
A14R8	0757-0442	9	4	RESISTOR 18K 1% .125W F TC=0+-100	24546	C4-1/8-T0-1802-F
A14R9	0698-3450	9	1	RESISTOR 42.2K 1% .125W F TC=0+-100	24546	C4-1/8-T0-4222-F
A14R10	2100-2633	5	2	RESISTOR-TRMR 1K 10% C SIDE-ADJ 1-TRN	30983	ET50X102
A14R11	0698-3155	1	1	RESISTOR 4.64K 1% .125W F TC=0+-100	24546	C4-1/8-T0-4641-F
A14R12	0757-0458	7	2	RESISTOR 51.1K 1% .125W F TC=0+-100	24546	C4-1/8-T0-5112-F
A14R13	0757-0401	0	8	RESISTOR 100 1% .125W F TC=0+-100	24546	C4-1/8-T0-1011-F
A14R14	0757-0460	1	1	RESISTOR 61.9K 1% .125W F TC=0+-100	24546	C4-1/8-T0-6192-F
A14R15	0757-0458	7	2	RESISTOR 51.1K 1% .125W F TC=0+-100	24546	C4-1/8-T0-5112-F
A14R16	0757-0180	2	1	RESISTOR 31.6 1% .125W F TC=0+-100	28480	0757-0180
A14R17	0757-0464	5	1	RESISTOR 90.9K 1% .125W F TC=0+-100	24546	C4-1/8-T0-9092-F
A14R18	0698-3136	8	2	RESISTOR 17.8K 1% .125W F TC=0+-100	24546	C4-1/8-T0-1782-F
A14R19	0757-0123	3	1	RESISTOR 34.8K 1% .125W F TC=0+-100	28480	0757-0123
A14R20	0698-0983	8	2	RESISTOR 1.76K 1% .125W F TC=0+-100	24546	C4-1/8-T0-1961-F
A14R21	2100-2489	9	2	RESISTOR-TRMR 5K 10% C SIDE-ADJ 1-TRN	30983	ET50X502
A14R22	0698-3453	2	1	RESISTOR 196K 1% .125W F TC=0+-100	24546	C4-1/8-T0-1963-F
A14R23	2100-2514	1	1	RESISTOR-TRMR 20K 10% C SIDE-ADJ 1-TRN	30983	ET50W203
A14R24	0757-0274	5	3	RESISTOR 1.21K 1% .125W F TC=0+-100	24546	C4-1/8-T0-1211-F
A14R25	0757-0274	5	3	RESISTOR 1.21K 1% .125W F TC=0+-100	24546	C4-1/8-T0-1211-F
A14R26	0757-0274	5	3	RESISTOR 1.21K 1% .125W F TC=0+-100	24546	C4-1/8-T0-1211-F
A14R27	2100-2489	9	2	RESISTOR-TRMR 5K 10% C SIDE-ADJ 1-TRN	30983	ET50X502
A14R28	0757-0346	2	14	RESISTOR 10 1% .125W F TC=0+-100	24546	C4-1/8-T0-10R0-F
A14R29	0757-0346	2	14	RESISTOR 10 1% .125W F TC=0+-100	24546	C4-1/8-T0-10R0-F
A14R30	2100-2522	1	3	RESISTOR-TRMR 10K 10% C SIDE-ADJ 1-TRN	30983	ET50X103
A14R31	0757-0346	2	2	RESISTOR 10 1% .125W F TC=0+-100	24546	C4-1/8-T0-10R0-F
A14R32	0757-0346	2	2	RESISTOR 10 1% .125W F TC=0+-100	24546	C4-1/8-T0-10R0-F
A14R33	2100-2522	1	1	RESISTOR-TRMR 10K 10% C SIDE-ADJ 1-TRN	30983	ET50X103
A14R34	2100-2521	0	1	RESISTOR-TRMR 2K 10% C SIDE-ADJ 1-TRN	30983	ET50X202
A14R35	0757-0346	2	2	RESISTOR 10 1% .125W F TC=0+-100	24546	C4-1/8-T0-10R0-F
A14R36	0757-0346	2	2	RESISTOR 10 1% .125W F TC=0+-100	24546	C4-1/8-T0-10R0-F
A14R37	0757-0442	9	9	RESISTOR 10K 1% .125W F TC=0+-100	24546	C4-1/8-T0-1002-F
A14R38	0698-3151	7	1	RESISTOR 2.87K 1% .125W F TC=0+-100	24546	C4-1/8-T0-2871-F
A14R39	2100-2520	9	1	RESISTOR-TRMR 50 20% C SIDE-ADJ 1-TRN	30983	ET50X500
A14R40	0757-0442	9	9	RESISTOR 10K 1% .125W F TC=0+-100	24546	C4-1/8-T0-1002-F
A14R41	0757-0290	5	1	RESISTOR 6.19K 1% .125W F TC=0+-100	19701	MF4C1/8-T0-6191-F
A14R42	0757-3200	7	1	RESISTOR 5.62K 1% .125W F TC=0+-100	24546	C4-1/8-T0-5621-F
A14R43	0757-0447	4	3	RESISTOR 16.2K 1% .125W F TC=0+-100	24546	C4-1/8-T0-1622-F
A14R44	0757-0420	3	2	RESISTOR 750 1% .125W F TC=0+-100	24546	C4-1/8-T0-7511-F
A14R45	0698-3444	1	8	RESISTOR 316 1% .125W F TC=0+-100	24546	C4-1/8-T0-316R-F
A14R46	0698-3156	2	1	RESISTOR 14.7K 1% .125W F TC=0+-100	24546	C4-1/8-T0-1472-F
A14R47	0757-0346	2	2	RESISTOR 10 1% .125W F TC=0+-100	24546	C4-1/8-T0-10R0-F
A14R48	0698-3150	6	4	RESISTOR 2.37K 1% .125W F TC=0+-100	24546	C4-1/8-T0-2371-F
A14R49	0698-3132	4	1	RESISTOR 261 1% .125W F TC=0+-100	24546	C4-1/8-T0-2610-F
A14R50	0757-0277	0	4	RESISTOR 3.16K 1% .125W F TC=0+-100	24546	C4-1/8-T0-3161-F
A14R51	0757-0346	2	2	RESISTOR 10 1% .125W F TC=0+-100	24546	C4-1/8-T0-10R0-F
A14R52	0698-3444	1	1	RESISTOR 316 1% .125W F TC=0+-100	24546	C4-1/8-T0-316R-F
A14R53	0757-0444	1	6	RESISTOR 12.1K 1% .125W F TC=0+-100	24546	C4-1/8-T0-1212-F
A14R54	0757-0444	1	6	RESISTOR 12.1K 1% .125W F TC=0+-100	24546	C4-1/8-T0-1212-F
A14R55	0757-0440	7	8	RESISTOR 7.5K 1% .125W F TC=0+-100	24546	C4-1/8-T0-7501-F
A14R56	0757-0401	0	3	RESISTOR 100 1% .125W F TC=0+-100	24546	C4-1/8-T0-1011-F
A14R57	0757-0280	3	3	RESISTOR 1K 1% .125W F TC=0+-100	24546	C4-1/8-T0-1001-F
A14R58	0757-0346	2	2	RESISTOR 10 1% .125W F TC=0+-100	24546	C4-1/8-T0-10R0-F
A14R59	0698-3150	6	6	RESISTOR 2.37K 1% .125W F TC=0+-100	24546	C4-1/8-T0-2371-F
A14R60	0698-3444	1	1	RESISTOR 316 1% .125W F TC=0+-100	24546	C4-1/8-T0-316R-F
A14R61	0757-0280	3	3	RESISTOR 1K 1% .125W F TC=0+-100	24546	C4-1/8-T0-1001-F
A14R62	0757-0444	1	7	RESISTOR 12.1K 1% .125W F TC=0+-100	24546	C4-1/8-T0-1212-F
A14R63	0757-0444	1	7	RESISTOR 12.1K 1% .125W F TC=0+-100	24546	C4-1/8-T0-1212-F
A14R64	0757-0440	7	1	RESISTOR 7.5K 1% .125W F TC=0+-100	24546	C4-1/8-T0-7501-F
A14R65	0757-0401	0	3	RESISTOR 100 1% .125W F TC=0+-100	24546	C4-1/8-T0-1011-F
A14R66	0757-0280	3	3	RESISTOR 1K 1% .125W F TC=0+-100	24546	C4-1/8-T0-1001-F
A14R67	0757-0346	2	2	RESISTOR 10 1% .125W F TC=0+-100	24546	C4-1/8-T0-10R0-F
A14R68	0698-8958	2	1	RESISTOR 511K 1% .125W F TC=0+-100	28480	0698-8958
A14R69	2100-2692	6	1	RESISTOR-TRMR 1M 20% C SIDE-ADJ 1-TRN	30983	ET50X105
A14R70	0698-3444	1	1	RESISTOR 316 1% .125W F TC=0+-100	24546	C4-1/8-T0-316R-F

*Indicates factory selected value

TABLE 8-14. A14 LOG AMPLIFIER ASSEMBLY, REPLACEABLE PARTS (4 OF 5)

Reference Designation	HP Part Number	C D	Qty	Description	Mfr Code	Mfr Part Number
A14R71	0757-0279	0		RESISTOR 3.16K 1% .125W F TC=0+-100	24546	C4-1/8-T0-3161-F
A14R72	0757-0444	1		RESISTOR 12.1K 1% .125W F TC=0+-100	24546	C4-1/8-T0-1212-F
A14R73	0757-0444	1		RESISTOR 12.1K 1% .125W F TC=0+-100	24546	C4-1/8-T0-1212-F
A14R74	0757-0440	7		RESISTOR 7.5K 1% .125W F TC=0+-100	24546	C4-1/8-T0-7501-F
A14R75	0757-0401	0		RESISTOR 100 1% .125W F TC=0+-100	24546	C4-1/8-T0-101 F
A14R76	0757-0280	3		RESISTOR 1K 1% .125W F TC=0+-100	24546	C4-1/8-T0-1001-F
A14R77	0757-0346	2		RESISTOR 10 1% .125W F TC=0+-100	24546	C4-1/8-T0-10R0-F
A14R78	0698-3150	6		RESISTOR 2.37K 1% .125W F TC=0+-100	24546	C4-1/8-T0-2371-F
A14R79	0698-3444	1		RESISTOR 316 1% .125W F TC=0+-100	24546	C4-1/8-T0-316R-F
A14R80	0757-0289	2	6	RESISTOR 13.3K 1% .125W F TC=0+-100	19701	MF4C1/8-T0-1332-F
A14R81	0757-0289	2		RESISTOR 13.3K 1% .125W F TC=0+-100	19701	MF4C1/8-T0-1332-F
A14R82	0757-0440	7		RESISTOR 7.5K 1% .125W F TC=0+-100	24546	C4-1/8-T0-7501-F
A14R83	0757-0401	0		RESISTOR 100 1% .125W F TC=0+-100	24546	C4-1/8-T0-101 F
A14R84	0757-0280	3		RESISTOR 1K 1% .125W F TC=0+-100	24546	C4-1/8-T0-1001-F
A14R85	0757-0279	0		RESISTOR 3.16K 1% .125W F TC=0+-100	24546	C4-1/8-T0-3161 F
A14R86	0757-0346	2		RESISTOR 10 1% .125W F TC=0+-100	24546	C4-1/8-T0-10R0-F
A14R87	0698-3444	1		RESISTOR 316 1% .125W F TC=0+-100	24546	C4-1/8-T0-316R-F
A14R88	2160-2522	1		RESISTOR-TRMR 10K 10% C SIDE-ADJ 1-TRN	30983	ET50X103
A14R89	0757-0440	7		RESISTOR 7.5K 1% .125W F TC=0+-100	24546	C4-1/8-T0-7501-F
A14R90	0757-0403	2	2	RESISTOR 121 1% .125W F TC=0+-100	24546	C4-1/8-T0-121R-F
A14R91	0757-0289	2		RESISTOR 13.3K 1% .125W F TC=0+-100	19701	MF4C1/8-T0-1332-F
A14R92	0757-0289	2		RESISTOR 13.3K 1% .125W F TC=0+-100	19701	MF4C1/8-T0-1332-F
A14R93	0698-3153	9	2	RESISTOR 3.03K 1% .125W F TC=0+-100	24546	C4-1/8-T0-3031-F
A14R94	0698-3150	6		RESISTOR 2.37K 1% .125W F TC=0+-100	24546	C4-1/8-T0-2371-F
A14R95	0757-0346	2		RESISTOR 10 1% .125W F TC=0+-100	24546	C4-1/8-T0-10R0-F
A14R96	0698-3444	1		RESISTOR 316 1% .125W F TC=0+-100	24546	C4-1/8-T0-316R-F
A14R97	0757-0289	2		RESISTOR 13.3K 1% .125W F TC=0+-100	19701	MF4C1/8-T0-1332-F
A14R98	0757-0289	2		RESISTOR 13.3K 1% .125W F TC=0+-100	19701	MF4C1/8-T0-1332-F
A14R99	0757-0440	7		RESISTOR 7.5K 1% .125W F TC=0+-100	24546	C4-1/8-T0-7501-F
A14R100	0757-0403	2		RESISTOR 121 1% .125W F TC=0+-100	24546	C4-1/8-T0-121R-F
A14R101	0698-3153	9		RESISTOR 3.03K 1% .125W F TC=0+-100	24546	C4-1/8-T0-3031-F
A14R102	0757-0346	2		RESISTOR 10 1% .125W F TC=0+-100	24546	C4-1/8-T0-10R0-F
A14R103	0757-0401	0		RESISTOR 100 1% .125W F TC=0+-100	24546	C4-1/8-T0-101 F
A14R104	0757-0401	0		RESISTOR 100 1% .125W F TC=0+-100	24546	C4-1/8-T0-101 F
A14R105	0698-3444	1		RESISTOR 316 1% .125W F TC=0+-100	24546	C4-1/8-T0-316R-F
A14R106	0757-0417	8	1	RESISTOR 562 1% .125W F TC=0+-100	24546	C4-1/8-T0-562R-F
A14R107	0757-0199	3	1	RESISTOR 21.5K 1% .125W F TC=0+-100	24546	C4-1/8-T0-2152-F
A14R108	0698-3434	9	1	RESISTOR 34.8 1% .125W F TC=0+-100	24546	C4-1/8-T0-348R-F
A14R109	0757-0400	9	1	RESISTOR 90.9 1% .125W F TC=0+-100	24546	C4-1/8-T0-909R-F
A14R110	0757-0418	9	2	RESISTOR 619 1% .125W F TC=0+-100	24546	C4-1/8-T0-619R-F
A14R111	0698-3440	7	1	RESISTOR 196 1% .125W F TC=0+-100	24546	C4-1/8-T0-196R-F
A14R112	0757-0280	3		RESISTOR 1K 1% .125W F TC=0+-100	24546	C4-1/8-T0-1001-F
A14R113	0757-0280	3		RESISTOR 1K 1% .125W F TC=0+-100	24546	C4-1/8-T0-1001-F
A14R114	0698-3136	8		RESISTOR 17.8K 1% .125W F TC=0+-100	24546	C4-1/8-T0-1782-F
A14R115	0757-0401	0		RESISTOR 100 1% .125W F TC=0+-100	24546	C4-1/8-T0-101 F
A14R116	0757-0418	9		RESISTOR 619 1% .125W F TC=0+-100	24546	C4-1/8-T0-619R-F
A14R117	0757-0440	7		RESISTOR 7.5K 1% .125W F TC=0+-100	24546	C4-1/8-T0-7501-F
A14R118	0698-0085	0	1	RESISTOR 2.61K 1% .125W F TC=0+-100	24546	C4-1/8-T0-2611-F
A14R119	0698-3438	3	1	RESISTOR 147 1% .125W F TC=0+-100	24546	C4-1/8-T0-147R-F
A14R120	0757-0439	4	1	RESISTOR 6.81K 1% .125W F TC=0+-100	24546	C4-1/8-T0-6811-F
A14R121	2100-2633	5		RESISTOR-TRMR 1K 10% C SIDE-ADJ 1-TRN	30983	ET50X102
A14R122	0757-0420	3		RESISTOR 750 1% .125W F TC=0+-100	24546	C4-1/8-T0-751-F
A14R123	0757-0440	7		RESISTOR 7.5K 1% .125W F TC=0+-100	24546	C4-1/8-T0-7501-F
A14R124	0757-0447	4		RESISTOR 16.2K 1% .125W F TC=0+-100	24546	C4-1/8-T0-1622-F
A14R125	0757-0447	4		RESISTOR 16.2K 1% .125W F TC=0+-100	24546	C4-1/8-T0-1622-F
A14R126	0757-0465	6		RESISTOR 100K 1% .125W F TC=0+-100	24546	C4-1/8-T0-1003-F
A14R127	0757-0465	6		RESISTOR 100K 1% .125W F TC=0+-100	24546	C4-1/8-T0-1003-F
A14R128	0757-0465	6		RESISTOR 100K 1% .125W F TC=0+-100	24546	C4-1/8-T0-1003-F
A14R129	0698-0083	8		RESISTOR 1.96K 1% .125W F TC=0+-100	24546	C4-1/8-T0-1961-F
A14R130	0757-0279	0		RESISTOR 3.16K 1% .125W F TC=0+-100	24546	C4-1/8-T0-3161-F
A14R131	0757-0402	1	1	RESISTOR 110 1% .125W F TC=0+-100	24546	C4-1/8-T0-111-F
A14R132	0757-0438	3	1	RESISTOR 5.11K 1% .125W F TC=0+-100	24546	C4-1/8-T0-5111-F
A14R133	0698-7212	9	2	RESISTOR 100 1% .05W F TC=0+-100	24546	C3-1/8-T0-100R-F
A14R134	0698-7212	9		RESISTOR 160 1% .05W F TC=0+-100	24546	C3-1/8-T0-100R-F
A14TP1	0360-0535	0	10	TERMINAL TEST POINT PCB	00000	ORDER BY DESCRIPTION
A14TP2	0360-0535	0		TERMINAL TEST POINT PCB	00000	ORDER BY DESCRIPTION
A14TP3	0360-0535	0		TERMINAL TEST POINT PCB	00000	ORDER BY DESCRIPTION
A14TP4	0360-0535	0		TERMINAL TEST POINT PCB	00000	ORDER BY DESCRIPTION
A14TP5	0360-0535	0		TERMINAL TEST POINT PCB	00000	ORDER BY DESCRIPTION
A14TP6	0360-0535	0		TERMINAL TEST POINT PCB	00000	ORDER BY DESCRIPTION
A14TP7	0360-0535	0		TERMINAL TEST POINT PCB	00000	ORDER BY DESCRIPTION
A14TP8	0360-0535	0		TERMINAL TEST POINT PCB	00000	ORDER BY DESCRIPTION
A14TP9	0360-0535	0		TERMINAL TEST POINT PCB	00000	ORDER BY DESCRIPTION
A14TP10	0360-0535	0		TERMINAL TEST POINT PCB	00000	ORDER BY DESCRIPTION

*Indicates factory selected value

TABLE 8-14. A14 LOG AMPLIFIER ASSEMBLY, REPLACEABLE PARTS (5 OF 5)

Reference Designation	HP Part Number	C D	Qty	Description	Mfr Code	Mfr Part Number
A14U1	1826-0092	3	2	IC OP AMP GP DUAL TO-99 PKG	28480	1826-0092
A14U2	1826-0092	3		IC OP AMP GP DUAL TO-99 PKG	28480	1826-0092
A14VR1	1902-0901	5	1	DIODE-ZNR 5.4V 1% DO-35 PD=.4W TC=+.046%	28489	1902-0901

*Indicates factory selected value

A14 LOG AMPLIFIER ASSEMBLY 5061-5411

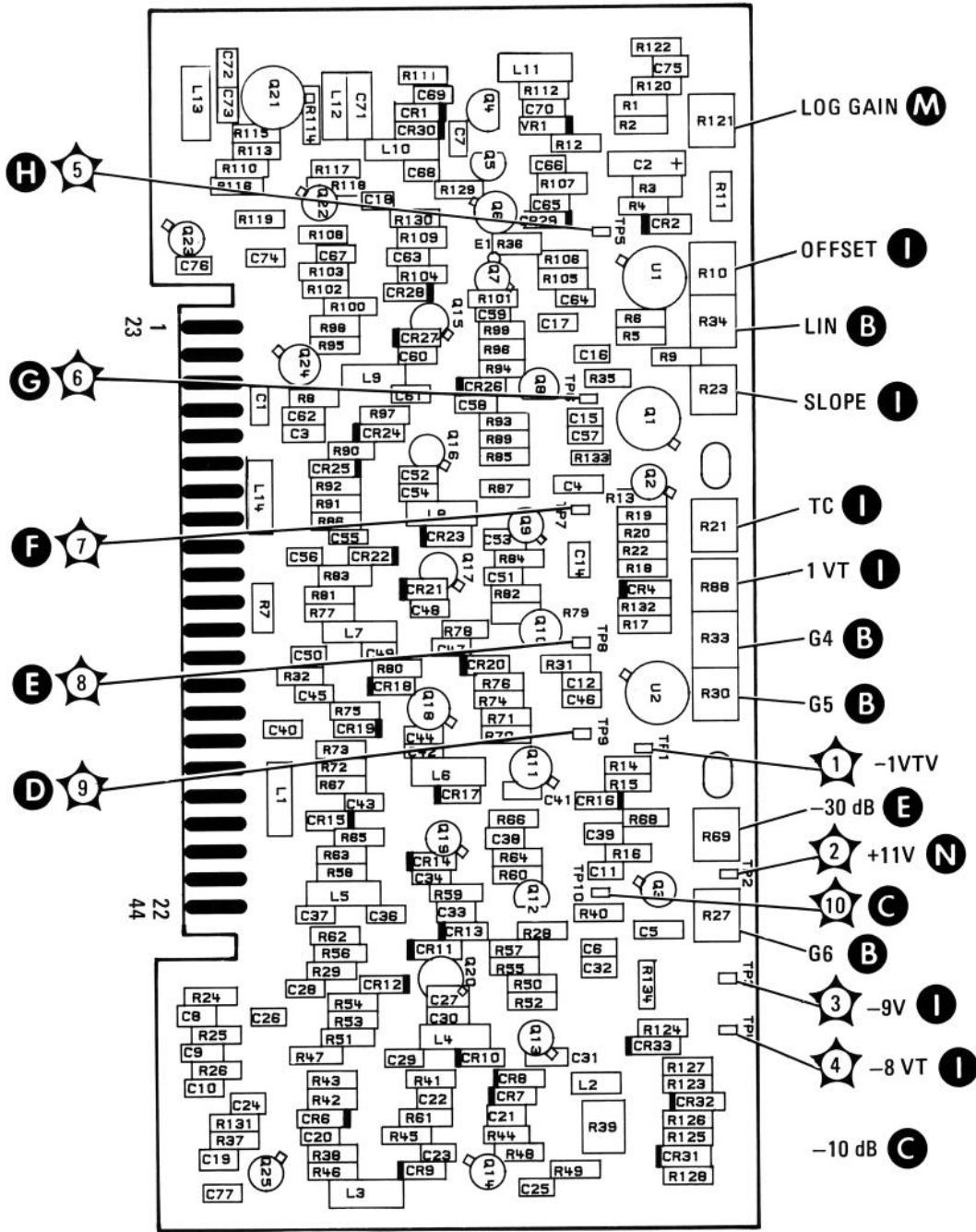

FIGURE 8-53. A14 LOG AMPLIFIER ASSEMBLY, COMPONENT LOCATIONS

A15 VERTICAL DRIVER AND BLANKING, CIRCUIT DESCRIPTION

General Description

The Vertical Driver and Blanking Assembly provides a preamplifier circuit to amplify the detected and filtered video from the log amplifier. The video signal needed to trigger the sweep generator in VIDEO TRIGGER mode is picked off at the preamplifier. A vertical driver (differential amplifier) converts the signal to drive the vertical deflection plates (push-pull output).

The blanking and pen lift drive signals are also generated on assembly A15.

Preamplifier (A)

The detected and filtered video input (0V to 0.8V) from the Log Amplifier Assembly A14 is applied to the gate of A15Q17A. A15Q17, Q11, Q12, and Q18 make up a differential amplifier. The gate of Q17A is the noninverting input and the gate of Q17B is the inverting input. The output at the emitter of A15Q18 is feedback applied to the gate of Q17B through voltage divider A15R11, R12, and R13. The voltage gain of the preamplifier is $1 + R11/(R12 + R13) = 10$. With an input voltage range of 0V to 0.8V, the maximum signal measured at the output of A15Q18 (TP5) would be 8V. (This signal coupled through A15R17 is the trigger voltage for VIDEO TRIGGER mode.) A buffer amplifier consisting of A15U2A, U2B, and Q20 provides isolation between the preamplifier and vertical driver. A15U2D and Q13 are current sources to bias the differential amplifier.

The vertical deflection sensitivity of the following vertical driver is 0.8V for full-scale deflection. Since a maximum possible signal of 8V is available from the preamplifier, to obtain the correct signal amplitude, a divide-by-10 and an offset circuit are used.

10 dB/DIV and LIN. The preamplifier output is divided by 10 when LOG/LIN switch A2S2 is in either LIN or 10 dB/DIV. With LIN or 10 dB/DIV selected, +15V is applied to the Expand line, back biasing A15CR1, and turning A15Q19 on. Also A15CR2 is on and CR3 is back biased. With A15Q19 on, a voltage divider consisting of A15R18, R20, and Q19 divides the preamplifier output by 10.

1 dB/DIV: With 1 dB/DIV selected, the Expand line is open and A15Q19 is held off by A15CR1 and R22. The divide-by-10 circuit is disabled and the full 8V preamp voltage is available. Since only the 0.8V peak can be displayed, the signal to the buffer amplifier is offset by $-7.2V$ as follows: A current source A15U2C is on, drawing current through A15CR3 and R18. The voltage drop across R18 is set for 7.2V, so the 8V input is shifted $-7.2V$ below ground. When the signal goes below ground (0V), A15CR4 conducts and clamps the signal at $-0.6V$. The 1 dB OFFSET adjustment, A15R1, sets the current for the correct voltage shift.

-5.5V Temperature Compensated Supply (B)

The $-5.5V$ temperature-compensated supply controls four current sources: A15U2D, Q13, U2C, and Q15. The temperature-sensing element, A15U2E (connected as a diode), tracks the base-emitter temperature changes of the current-source transistors.

Vertical Driver (F)

The vertical driver is a differential amplifier that consists of A15Q2, Q3, Q6, Q7, and Q14 with Q15 as the current source. (See Figure 8-55.) The 0V to 0.8V vertical signal from the output of the preamplifier is converted to a push-pull signal to drive the CRT vertical deflection plates. A15Q14 is a dual transistor used as the input stage to the Vertical Driver circuit. The reference input level at the base of A15Q14A is set by the VERT POSN control, A2R6. The gain of the vertical driver is set by the voltage divider consisting of A15R39, R42, and VERT GAIN control A2R7. The transistor pairs A15Q2/Q6 and A15Q3/Q7 are current-to-voltage amplifiers and are driven by the current from the collectors of A15Q14A and B respectively. Diodes A15CR5 through CR8 protect the bases of A15Q2, Q3, Q6, and Q7 to prevent them from being driven more negative than approximately 0.6V (the voltage drop across a diode). The resistors A15R44 and R52 decouple the capacitive

load of the CRT plates from the emitters of A15Q2 and Q3, preventing overshoot and ringing in the vertical driver. A15Q21, CR11, and CR12 provide vertical driver input switching for normalizer compatibility. When the normalizer is not connected, pull-up resistor A15R56 places the cathode of A15CR11 at +15V, preventing CR11 from conducting. A15Q21 is turned on so the input to the vertical driver is from the output of the preamplifier. When the normalizer is connected and in the BYPASS mode, the L NORM line at A15J3 is high (+12V) preventing A15CR11 from conducting. When the normalizer is operating, the L NORM line is pulled low (-12V) causing A15CR11 to conduct. A15Q21 is turned off by the negative voltage at the gate, switching the vertical driver input to the normalizer output (Y NORM).

Blanking OR (E)

Normally A15Q4 is off placing a low at the base of A15Q9 and turning it on. A15Q4 requires a positive voltage or about 1 mA to turn on and cut Q9 off. A high into the OR circuit provides a high blanking output (0V) to the mainframe. There are four conditions that cause blanking of the sweep. (See Figure 8-56.) When the normalizer is not connected, pull-up resistor A15R56 places the cathode of A15CR12 at +15V, preventing CR12 from conducting. When the normalizer is connected and in the bypass mode, the L NORM line at A15J3 is high (+12V) keeping A15CR12 from conducting. When the normalizer is operating, the L NORM line is pulled low (-12V) causing A15CR12 to conduct. With A15CR12 conducting, the output of the blanking OR is held at a negative voltage level, inhibiting blanking from the 8558B.

Vertical/Baseline Comparator (D)

The vertical/baseline comparator circuit consists of A15Q16 and Q8. The baseline clipping reference voltage is set by front panel BASELINE CLIPPER control A2R2 which varies the base voltage of A15Q16. The vertical preamplifier output signal is applied to the base of A15Q8. The signal voltage at the base of A15Q8 is compared to the dc reference on Q16. When the signal voltage becomes more negative than the reference, Q8 turns on and the high input to its base turns A15Q4 on, blanking the display.

Sweep Ramp High/Low Limit Comparator (C)

Operational amplifier A15Q1A and Q1B is connected to form a comparator circuit. A voltage divider made up of A15R6, R7, and R8 establishes a high and low voltage reference at U1A pin 2 and U1B pin 5. The switching limits are approximately +0.6V at U1B pin 5 (low frequency blanking) and +6.8V at U1A pin 2 (high frequency blanking). The signal to the other inputs of the comparator is the frequency analog voltage from the YIG main coil swept driver. The frequency analog input voltage is proportional to the instantaneous frequency to which the analyzer is tuned and sweeps from 0.7V to 6.7V as the analyzer tunes from 0 to 1500 MHz. If the YIG tuning voltage at U1B pin 6 goes below 0.6V, the output of U1B rises to about +14V. This turns on A15Q4 and blanks the display. If the YIG tuning voltage at U1A pin 2 rises above 6.8V, the output of U1A rises to about +14V turning on A15Q4. Blanking of the display occurs whenever the analyzer is swept below about -30 MHz or above about 1600 MHz.

Pen Lift Driver G

The display is blanked during retrace and the dead time of the sweep voltage. The Retrace Blanking input from A8Q9 in the sweep generator circuit is applied to the emitter of buffer amplifier A15Q1. When the sweep ramp is turned off (dead time), the Retrace Blanking signal rises to +10V. The +10V connected to the base of A15Q4 produces the blanking output. The same +10V Retrace Blanking input is applied to the base of A15Q5, turning Q5 on and Q10 off. The collector of A15Q10 then rises to +15V. A15Q10 provides a signal that can be used to drive the Pen Lift input on an X-Y recorder. This signal causes the pen to lift during the analyzer sweep retrace and dead time. Breakdown diodes A15VR2 and VR3 suppress the high positive and negative voltage transients that some X-Y recorder pen lift coils can generate.

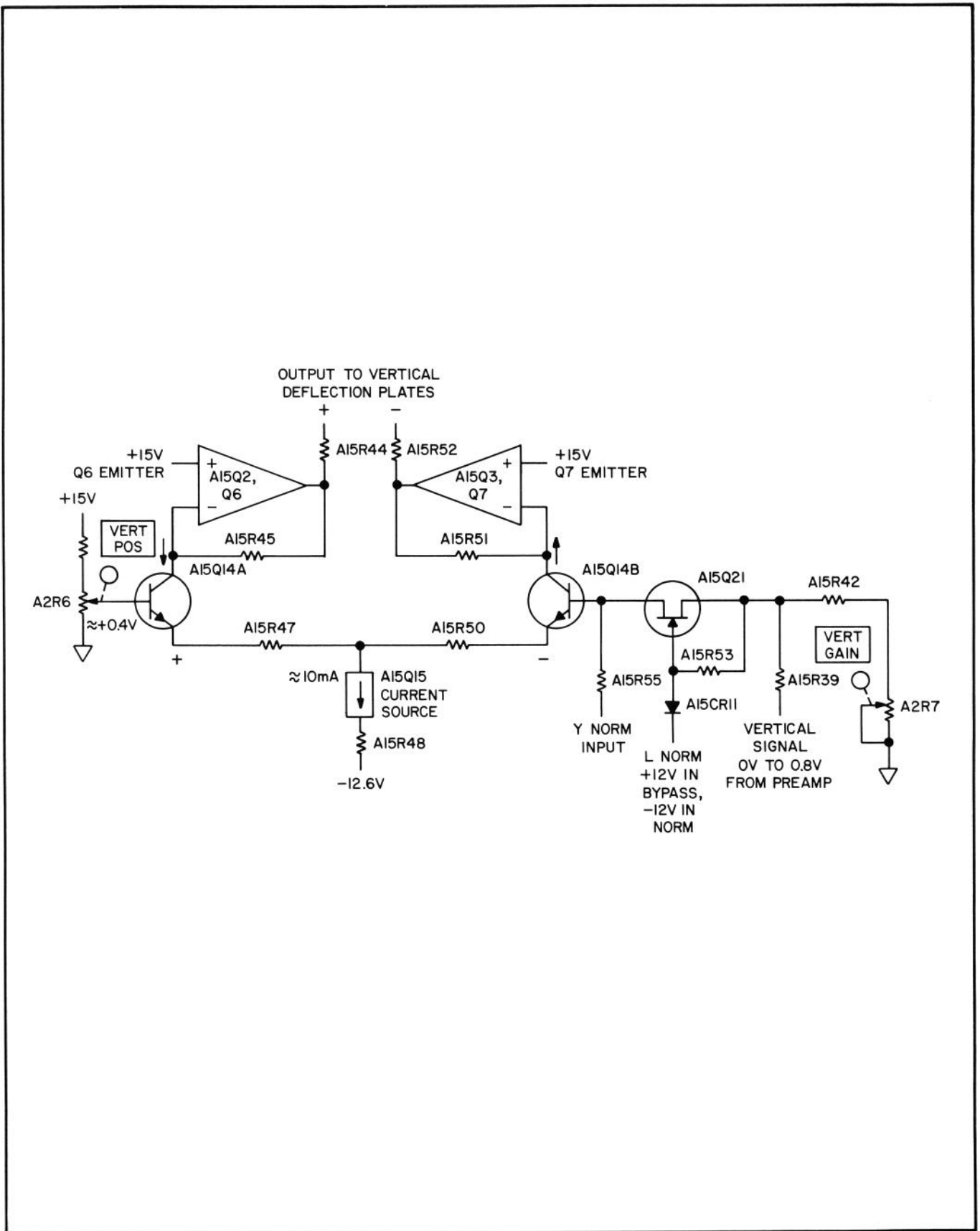

FIGURE 8-55. SIMPLIFIED VERTICAL DRIVER CIRCUIT

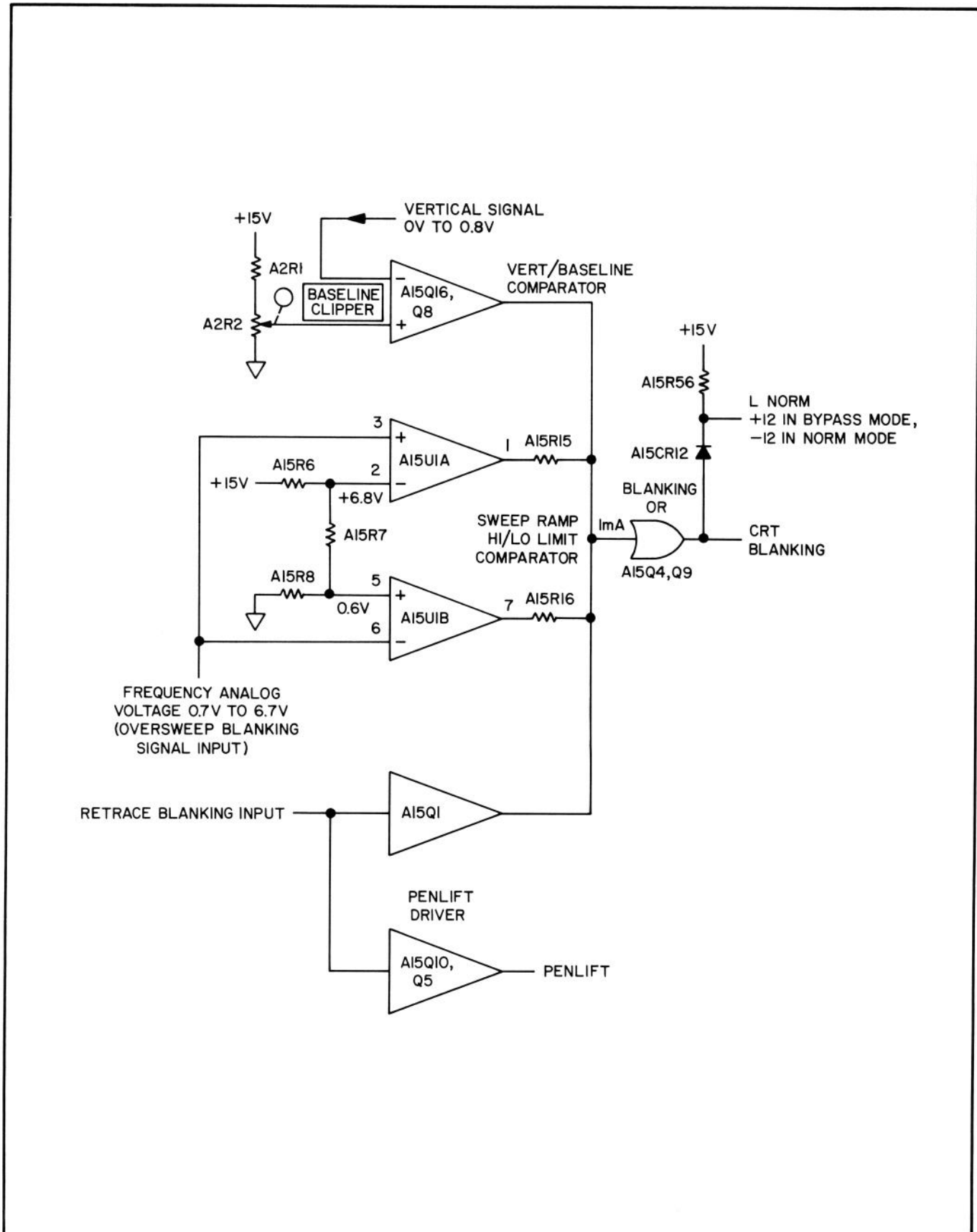

FIGURE 8-56. SIMPLIFIED BLANKING CIRCUIT

TABLE 8-15. A15 VERTICAL DRIVER AND BLANKING ASSEMBLY, REPLACEABLE PARTS (1 OF 2)

Reference Designation	HP Part Number	C D	Qty	Description	Mfr Code	Mfr Part Number
A15	08558-60115	9	1	VERTICAL DRIVE AND BLANKING ASSEMBLY	28480	08558-60115
A15C1	0180-0197	8	4	CAPACITOR-FXD 2.2UF+-10% 20VDC TA	56289	150D225X9020A2
A15C2	0180-0197	8	4	CAPACITOR-FXD 2.2UF+-10% 20VDC TA	56289	150D225X9020A2
A15C3	0180-0197	8	4	CAPACITOR-FXD 2.2UF+-10% 20VDC TA	56289	150D225X9020A2
A15C4	0160-2055	9	2	CAPACITOR-FXD .01UF +80-20% 100VDC CER	28480	0160-2055
A15C5	0180-0197	8	4	CAPACITOR-FXD 2.2UF+-10% 20VDC TA	56289	150D225X9020A2
A15C6	0160-2055	9	2	CAPACITOR-FXD .01UF +80-20% 100VDC CER	28480	0160-2055
A15CR1	1901-0040	1	7	DIODE-SWITCHING 30V 50MA 2NS DO-35	28480	1901-0040
A15CR2	1901-0040	1	7	DIODE-SWITCHING 30V 50MA 2NS DO-35	28480	1901-0040
A15CR3	1901-0040	1	7	DIODE-SWITCHING 30V 50MA 2NS DO-35	28480	1901-0040
A15CR4	1901-0535	9	1	DIODE-SM SIG SCHOTTKY	28480	1901-0535
A15CR5	1901-0040	1	7	DIODE-SWITCHING 30V 50MA 2NS DO-35	28480	1901-0040
A15CR6	1901-0040	1	7	DIODE-SWITCHING 30V 50MA 2NS DO-35	28480	1901-0040
A15CR7	1901-0040	1	7	DIODE-SWITCHING 30V 50MA 2NS DO-35	28480	1901-0040
A15CR8	1901-0040	1	7	DIODE-SWITCHING 30V 50MA 2NS DO-35	28480	1901-0040
A15CR9	1901-0050	3	3	DIODE-SWITCHING 80V 200MA 2NS DO-35	28480	1901-0050
A15CR10	1901-0050	3	3	DIODE-SWITCHING 80V 200MA 2NS DO-35	28480	1901-0050
A15CR11	1901-0050	3	3	DIODE-SWITCHING 80V 200MA 2NS DO-35	28480	1901-0050
A15CR12	1901-0518	8	1	DIODE-SM SIG SCHOTTKY	28480	1901-0518
A15L1	9140-0179	1	2	INDUCTOR RF-CH-MLD 22UH 10% .166DX,365LG	28480	9140-0179
A15L2	9140-0179	1	2	INDUCTOR RF-CH-MLD 22UH 10% .166DX,365LG	28480	9140-0179
A15Q1	1853-0007	7	3	TRANSISTOR PNP 2N3251 SI TO-18 PD=360MW	04713	2N3251
A15Q2	1854-0234	4	4	TRANSISTOR NPN 2N3440 SI TO-5 PD=1W	3L585	2N3440
A15Q3	1854-0234	4	4	TRANSISTOR NPN 2N3440 SI TO-5 PD=1W	3L585	2N3440
A15Q4	1854-0009	1	1	TRANSISTOR NPN SI PD=300MW FT=600MHZ	04713	2N739
A15Q5	1854-0404	0	5	TRANSISTOR NPN SI TO-18 PD=360MW	28480	1854-0404
A15Q6	1854-0234	4	4	TRANSISTOR NPN 2N3440 SI TO-5 PD=1W	3L585	2N3440
A15Q7	1854-0234	4	4	TRANSISTOR NPN 2N3440 SI TO-5 PD=1W	3L585	2N3440
A15Q8	1853-0007	7	3	TRANSISTOR PNP 2N3251 SI TO-18 PD=360MW	04713	2N3251
A15Q9	1854-0019	3	1	TRANSISTOR NPN SI TO-18 PD=360MW	28480	1854-0019
A15Q10	1854-0039	7	1	TRANSISTOR NPN 2N3053S SI TO-39 PD=1W	3L585	2N3053S
A15Q11	1853-0451	5	2	TRANSISTOR PNP 2N3799 SI TO-18 PD=360MW	01295	2N3799
A15Q12	1853-0451	5	2	TRANSISTOR PNP 2N3799 SI TO-18 PD=360MW	01295	2N3799
A15Q13	1854-0404	0	1	TRANSISTOR NPN SI TO-18 PD=360MW	28480	1854-0404
A15Q14	1854-0475	5	1	TRANSISTOR-DUAL NPN PD=750MW	28480	1854-0475
A15Q15	1854-0404	0	1	TRANSISTOR NPN SI TO-18 PD=360MW	28480	1854-0404
A15Q16	1853-0007	7	3	TRANSISTOR PNP 2N3251 SI TO-18 PD=360MW	04713	2N3251
A15Q17	1855-0376	7	1	TRANSISTOR-JFET DUAL N-CHAN D-MODE SI	28480	1855-0376
A15Q18	1854-0404	0	1	TRANSISTOR NPN SI TO-18 PD=360MW	28480	1854-0404
A15Q19	1855-0417	7	1	TRANSISTOR J-FET N-CHAN D-MODE TO-18 SI	28480	1855-0417
A15Q20	1854-0404	0	1	TRANSISTOR NPN SI TO-18 PD=360MW	28480	1854-0404
A15Q21	1855-0020	8	1	TRANSISTOR J-FET N-CHAN D-MODE TO-18 SI	28480	1855-0020
A15R1	2100-3123	0	1	RESISTOR-TRMR 500 10% C SIDE-ADJ 17-TRN	02111	43P501
A15R2	0757-0199	3	6	RESISTOR 21.5K 1% .125W F TC=0+-100	24546	C4-1/8-T0-2152-F
A15R3	0757-0420	3	2	RESISTOR 750 1% .125W F TC=0+-100	24546	C4-1/8-T0-751-F
A15R4	0757-0280	3	3	RESISTOR 1K 1% .125W F TC=0+-100	24546	C4-1/8-T0-1001-F
A15R5	0757-0279	0	3	RESISTOR 3.16K 1% .125W F TC=0+-100	24546	C4-1/8-T0-3161-F
A15R6	0698-3156	2	4	RESISTOR 14.7K 1% .125W F TC=0+-100	24546	C4-1/8-T0-1472-F
A15R7	0757-0444	1	2	RESISTOR 12.1K 1% .125W F TC=0+-100	24546	C4-1/8-T0-1212-F
A15R8	0757-0424	7	3	RESISTOR 1.1K 1% .125W F TC=0+-100	24546	C4-1/8-T0-1101-F
A15R9	0698-3156	2	4	RESISTOR 14.7K 1% .125W F TC=0+-100	24546	C4-1/8-T0-1472-F
A15R10	0757-0199	3	3	RESISTOR 21.5K 1% .125W F TC=0+-100	24546	C4-1/8-T0-2152-F
A15R11	0698-3155	1	3	RESISTOR 4.64K 1% .125W F TC=0+-100	24546	C4-1/8-T0-4641-F
A15R12	0757-0416	7	3	RESISTOR 511 1% .125W F TC=0+-100	24546	C4-1/8-T0-511R-F
A15R13	0683-0475	1	1	RESISTOR 4.7 5% .25W FC TC=-400/+500	01121	CB47G5
A15R14	0757-0424	7	3	RESISTOR 1.1K 1% .125W F TC=0+-100	24546	C4-1/8-T0-1101-F
A15R15	0757-0199	3	3	RESISTOR 21.5K 1% .125W F TC=0+-100	24546	C4-1/8-T0-2152-F
A15R16	0757-0199	3	3	RESISTOR 21.5K 1% .125W F TC=0+-100	24546	C4-1/8-T0-2152-F
A15R17	0757-0280	3	3	RESISTOR 1K 1% .125W F TC=0+-100	24546	C4-1/8-T0-1001-F
A15R18	0698-3155	1	3	RESISTOR 4.64K 1% .125W F TC=0+-100	24546	C4-1/8-T0-4641-F
A15R19	0698-0084	9	1	RESISTOR 2.15K 1% .125W F TC=0+-100	24546	C4-1/8-T0-2151-F
A15R20	0757-0416	7	3	RESISTOR 511 1% .125W F TC=0+-100	24546	C4-1/8-T0-511R-F
A15R21	0683-1055	5	1	RESISTOR 1M 5% .25W FC TC=-800/+900	01121	CB1055
A15R22	0757-0442	9	3	RESISTOR 10K 1% .125W F TC=0+-100	24546	C4-1/8-T0-1002-F
A15R23	0757-0465	6	2	RESISTOR 100K 1% .125W F TC=0+-100	24546	C4-1/8-T0-1003-F
A15R24	0757-0442	9	3	RESISTOR 10K 1% .125W F TC=0+-100	24546	C4-1/8-T0-1002-F
A15R25	0757-0199	3	3	RESISTOR 21.5K 1% .125W F TC=0+-100	24546	C4-1/8-T0-2152-F
A15R26*	0698-3153	9	1	RESISTOR 3.03K 1% .125W F TC=0+-100	24546	C4-1/8-T0-3031-F
A15R27	0698-3440	7	4	RESISTOR 196 1% .125W F TC=0+-100	24546	C4-1/8-T0-196R-F
A15R28	0698-3440	7	4	RESISTOR 196 1% .125W F TC=0+-100	24546	C4-1/8-T0-196R-F
A15R29	0757-0279	0	3	RESISTOR 3.16K 1% .125W F TC=0+-100	24546	C4-1/8-T0-3161-F
A15R30	0698-3156	2	4	RESISTOR 14.7K 1% .125W F TC=0+-100	24546	C4-1/8-T0-1472-F

*Indicates factory selected value

TABLE 8-15. A15 VERTICAL DRIVER AND BLANKING ASSEMBLY, REPLACEABLE PARTS (2 OF 2)

Reference Designation	HP Part Number	C D	Qty	Description	Mfr Code	Mfr Part Number
A15R31	0757-0444	1	4	RESISTOR 12.1K 1% .125W F TC=0+-100	24546	C4-1/8-T0-1212-F
A15R32	0698-3444	1		RESISTOR 316 1% .125W F TC=0+-100	24546	C4-1/8-T0-316R-F
A15R33	0757-0424	7		RESISTOR 1.1K 1% .125W F TC=0+-100	24546	C4-1/8-T0-1101-F
A15R34	0698-3156	2		RESISTOR 14.7K 1% .125W F TC=0+-100	24546	C4-1/8-T0-1472-F
A15R35	0757-0279	0		RESISTOR 3.16K 1% .125W F TC=0+-100	24546	C4-1/8-T0-3161-F
A15R36	0757-0200	7	1	RESISTOR 5.62K 1% .125W F TC=0+-100	24546	C4-1/8-T0-5621-F
A15R37	0757-0465	6		RESISTOR 100K 1% .125W F TC=0+-100	24546	C4-1/8-T0-1003-F
A15R38	0757-0199	3		RESISTOR 21.5K 1% .125W F TC=0+-100	24546	C4-1/8-T0-2152-F
A15R39	0698-3444	1		RESISTOR 316 1% .125W F TC=0+-100	24546	C4-1/8-T0-316R-F
A15R40	0757-0394	0		RESISTOR 51.1 1% .125W F TC=0+-100	24546	C4-1/8-T0-51R1-F
A15R41	0698-3155	1	2	RESISTOR 4.64K 1% .125W F TC=0+-100	24546	C4-1/8-T0-4641-F
A15R42	0757-0416	7		RESISTOR 511 1% .125W F TC=0+-100	24546	C4-1/8-T0-511R-F
A15R43	0757-0442	9		RESISTOR 10K 1% .125W F TC=0+-100	24546	C4-1/8-T0-1002-F
A15R44	0698-3444	1		RESISTOR 316 1% .125W F TC=0+-100	24546	C4-1/8-T0-316R-F
A15R45	0757-0837	6		RESISTOR 8.25K 1% .5W F TC=0+-100	28480	0757-0837
A15R46	0757-0844	5	2	RESISTOR 16.2K 1% .5W F TC=0+-100	28480	0757-0844
A15R47	0698-3440	7		RESISTOR 196 1% .125W F TC=0+-100	24546	C4-1/8-T0-196R-F
A15R48	0757-0426	3		RESISTOR 750 1% .125W F TC=0+-100	24546	C4-1/8-T0-751-F
A15R49	0757-0844	5		RESISTOR 16.2K 1% .5W F TC=0+-100	28480	0757-0844
A15R50	0698-3440	7		RESISTOR 196 1% .125W F TC=0+-100	24546	C4-1/8-T0-196R-F
A15R51	0757-0837	6	1	RESISTOR 8.25K 1% .5W F TC=0+-100	28480	0757-0837
A15R52	0698-3444	1		RESISTOR 316 1% .125W F TC=0+-100	24546	C4-1/8-T0-316R-F
A15R53	0698-3260	9		RESISTOR 464K 1% .125W F TC=0+-100	28480	0698-3260
A15R54	0698-3446	3		RESISTOR 383 1% .125W F TC=0+-100	24546	C4-1/8-T0-383R-F
A15R55	0757-0280	3		RESISTOR 1K 1% .125W F TC=0+-100	24546	C4-1/8-T0-1001-F
A15R56	0698-7284	5	1	RESISTOR 100K 1% .05W F TC=0+-100	24546	C3-1/8-T0-1003-F
A15TP1	1251-0600	0	4	CONNECTOR-SGL CONT PIN 1.14-MM-BSC-SZ SQ	28480	1251-0600
A15TP2	1251-0600	0		CONNECTOR-SGL CONT PIN 1.14-MM-BSC-SZ SQ	28480	1251-0600
A15TP3	1251-0600	0		CONNECTOR-SGL CONT PIN 1.14-MM-BSC-SZ SQ	28480	1251-0600
A15TP4	1251-0600	0		CONNECTOR-SGL CONT PIN 1.14-MM-BSC-SZ SQ	28480	1251-0600
A15U1	1826-0392	3	1	IC OP AMP GP DUAL TO-99 PKG	28480	1826-0392
A15U2	1858-0032	8	1	TRANSISTOR ARRAY 14-PIN PLSTC DIP	3L585	CA3146E
A15VR1	1932-0033	4	1	DIODE-ZNR 1N823 6.2V 5% DD-7 PD=.4W	24346	1N823
A15VR2	1902-0202	9	1	DIODE-ZNR 15V 5% PD=1W IR=50A	28480	1902-0202
A15VR3	1932-0556	6	1	DIODE-ZNR 20V 5% PD=1W IR=50A	28480	1932-0556
				MISCELLANEOUS		
	1200-0173	5	5	INSULATOR-XSTR DAP-CL	28480	1200-0173

*Indicates factory selected value

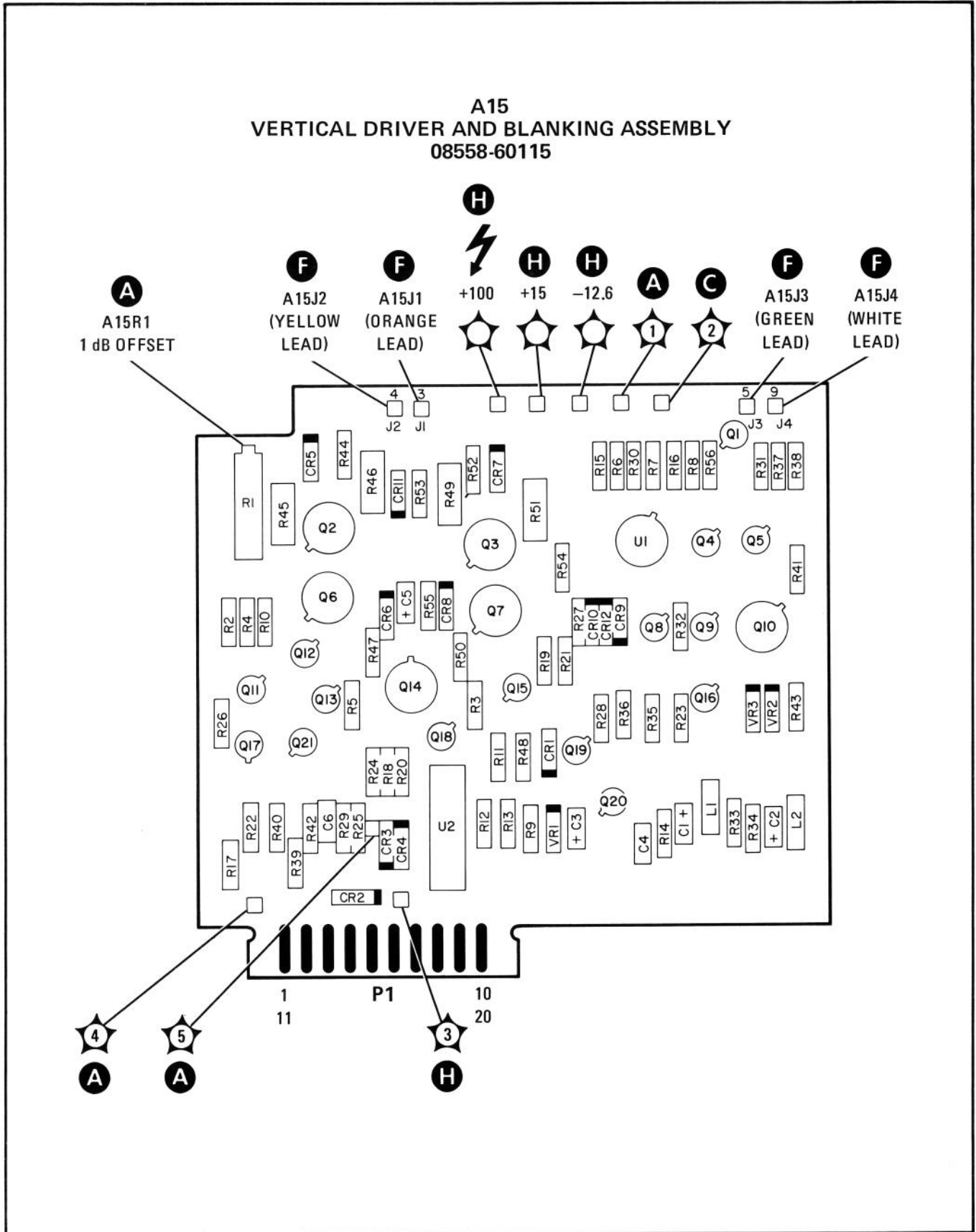

FIGURE 8-57. A15 VERTICAL DRIVER AND BLANKING ASSEMBLY, COMPONENT LOCATIONS

A15 VERTICAL DRIVER AND BLANKING, CIRCUIT DESCRIPTION

General Description

The Vertical Driver and Blanking Assembly provides a preamplifier circuit to amplify the detected and filtered video from the log amplifier. The video signal needed to trigger the sweep generator in VIDEO TRIGGER mode is picked off at the preamplifier. A vertical driver (differential amplifier) converts the signal to drive the vertical deflection plates (push-pull output).

The blanking and pen lift drive signals are also generated on assembly A15.

Preamplifier (A)

The detected and filtered video input (0V to 0.8V) from the Log Amplifier Assembly A14 is applied to the gate of A15Q17A. A15Q17, Q11, Q12, and Q18 make up a differential amplifier. The gate of Q17A is the noninverting input and the gate of Q17B is the inverting input. The output at the emitter of A15Q18 is feedback applied to the gate of Q17B through voltage divider A15R11, R12, and R13. The voltage gain of the preamplifier is $1 + R11/(R12 + R13) = 10$. With an input voltage range of 0V to 0.8V, the maximum signal measured at the output of A15Q18 (TP5) would be 8V. (This signal coupled through A15R17 is the trigger voltage for VIDEO TRIGGER mode.) A buffer amplifier consisting of A15U2A, U2B, and Q20 provides isolation between the preamplifier and vertical driver. A15U2D and Q13 are current sources to bias the differential amplifier.

The vertical deflection sensitivity of the following vertical driver is 0.8V for full-scale deflection. Since a maximum possible signal of 8V is available from the preamplifier, to obtain the correct signal amplitude, a divide-by-10 and an offset circuit are used.

10 dB/DIV and LIN. The preamplifier output is divided by 10 when LOG/LIN switch A2S2 is in either LIN or 10 dB/DIV. With LIN or 10 dB/DIV selected, +15V is applied to the Expand line, back biasing A15CR1, and turning A15Q19 on. Also A15CR2 is on and CR3 is back biased. With A15Q19 on, a voltage divider consisting of A15R18, R20, and Q19 divides the preamplifier output by 10.

1 dB/DIV: With 1 dB/DIV selected, the Expand line is open and A15Q19 is held off by A15CR1 and R22. The divide-by-10 circuit is disabled and the full 8V preamp voltage is available. Since only the 0.8V peak can be displayed, the signal to the buffer amplifier is offset by $-7.2V$ as follows: A current source A15U2C is on, drawing current through A15CR3 and R18. The voltage drop across R18 is set for 7.2V, so the 8V input is shifted $-7.2V$ below ground. When the signal goes below ground (0V), A15CR4 conducts and clamps the signal at $-0.6V$. The 1 dB OFFSET adjustment, A15R1, sets the current for the correct voltage shift.

-5.5V Temperature Compensated Supply (B)

The $-5.5V$ temperature-compensated supply controls four current sources: A15U2D, Q13, U2C, and Q15. The temperature-sensing element, A15U2E (connected as a diode), tracks the base-emitter temperature changes of the current-source transistors.

Vertical Driver (F)

The vertical driver is a differential amplifier that consists of A15Q2, Q3, Q6, Q7, and Q14 with Q15 as the current source. (See Figure 8-55.) The 0V to 0.8V vertical signal from the output of the preamplifier is converted to a push-pull signal to drive the CRT vertical deflection plates. A15Q14 is a dual transistor used as the input stage to the Vertical Driver circuit. The reference input level at the base of A15Q14A is set by the VERT POSN control, A2R6. The gain of the vertical driver is set by the voltage divider consisting of A15R39, R42, and VERT GAIN control A2R7. The transistor pairs A15Q2/Q6 and A15Q3/Q7 are current-to-voltage amplifiers and are driven by the current from the collectors of A15Q14A and B respectively. Diodes A15CR5 through CR8 protect the bases of A15Q2, Q3, Q6, and Q7 to prevent them from being driven more negative than approximately 0.6V (the voltage drop across a diode). The resistors A15R44 and R52 decouple the capacitive

load of the CRT plates from the emitters of A15Q2 and Q3, preventing overshoot and ringing in the vertical driver. A15Q21, CR11, and CR12 provide vertical driver input switching for normalizer compatibility. When the normalizer is not connected, pull-up resistor A15R56 places the cathode of A15CR11 at +15V, preventing CR11 from conducting. A15Q21 is turned on so the input to the vertical driver is from the output of the preamplifier. When the normalizer is connected and in the BYPASS mode, the L NORM line at A15J3 is high (+12V) preventing A15CR11 from conducting. When the normalizer is operating, the L NORM line is pulled low (-12V) causing A15CR11 to conduct. A15Q21 is turned off by the negative voltage at the gate, switching the vertical driver input to the normalizer output (Y NORM).

Blanking OR (E)

Normally A15Q4 is off placing a low at the base of A15Q9 and turning it on. A15Q4 requires a positive voltage or about 1 mA to turn on and cut Q9 off. A high into the OR circuit provides a high blanking output (0V) to the mainframe. There are four conditions that cause blanking of the sweep. (See Figure 8-56.) When the normalizer is not connected, pull-up resistor A15R56 places the cathode of A15CR12 at +15V, preventing CR12 from conducting. When the normalizer is connected and in the bypass mode, the L NORM line at A15J3 is high (+12V) keeping A15CR12 from conducting. When the normalizer is operating, the L NORM line is pulled low (-12V) causing A15CR12 to conduct. With A15CR12 conducting, the output of the blanking OR is held at a negative voltage level, inhibiting blanking from the 8558B.

Vertical/Baseline Comparator (D)

The vertical/baseline comparator circuit consists of A15Q16 and Q8. The baseline clipping reference voltage is set by front panel BASELINE CLIPPER control A2R2 which varies the base voltage of A15Q16. The vertical preamplifier output signal is applied to the base of A15Q8. The signal voltage at the base of A15Q8 is compared to the dc reference on Q16. When the signal voltage becomes more negative than the reference, Q8 turns on and the high input to its base turns A15Q4 on, blanking the display.

Sweep Ramp High/Low Limit Comparator (C)

Operational amplifier A15Q1A and Q1B is connected to form a comparator circuit. A voltage divider made up of A15R6, R7, and R8 establishes a high and low voltage reference at U1A pin 2 and U1B pin 5. The switching limits are approximately +0.6V at U1B pin 5 (low frequency blanking) and +6.8V at U1A pin 2 (high frequency blanking). The signal to the other inputs of the comparator is the frequency analog voltage from the YIG main coil swept driver. The frequency analog input voltage is proportional to the instantaneous frequency to which the analyzer is tuned and sweeps from 0.7V to 6.7V as the analyzer tunes from 0 to 1500 MHz. If the YIG tuning voltage at U1B pin 6 goes below 0.6V, the output of U1B rises to about +14V. This turns on A15Q4 and blanks the display. If the YIG tuning voltage at U1A pin 2 rises above 6.8V, the output of U1A rises to about +14V turning on A15Q4. Blanking of the display occurs whenever the analyzer is swept below about -30 MHz or above about 1600 MHz.

Pen Lift Driver G

The display is blanked during retrace and the dead time of the sweep voltage. The Retrace Blanking input from A8Q9 in the sweep generator circuit is applied to the emitter of buffer amplifier A15Q1. When the sweep ramp is turned off (dead time), the Retrace Blanking signal rises to +10V. The +10V connected to the base of A15Q4 produces the blanking output. The same +10V Retrace Blanking input is applied to the base of A15Q5, turning Q5 on and Q10 off. The collector of A15Q10 then rises to +15V. A15Q10 provides a signal that can be used to drive the Pen Lift input on an X-Y recorder. This signal causes the pen to lift during the analyzer sweep retrace and dead time. Breakdown diodes A15VR2 and VR3 suppress the high positive and negative voltage transients that some X-Y recorder pen lift coils can generate.

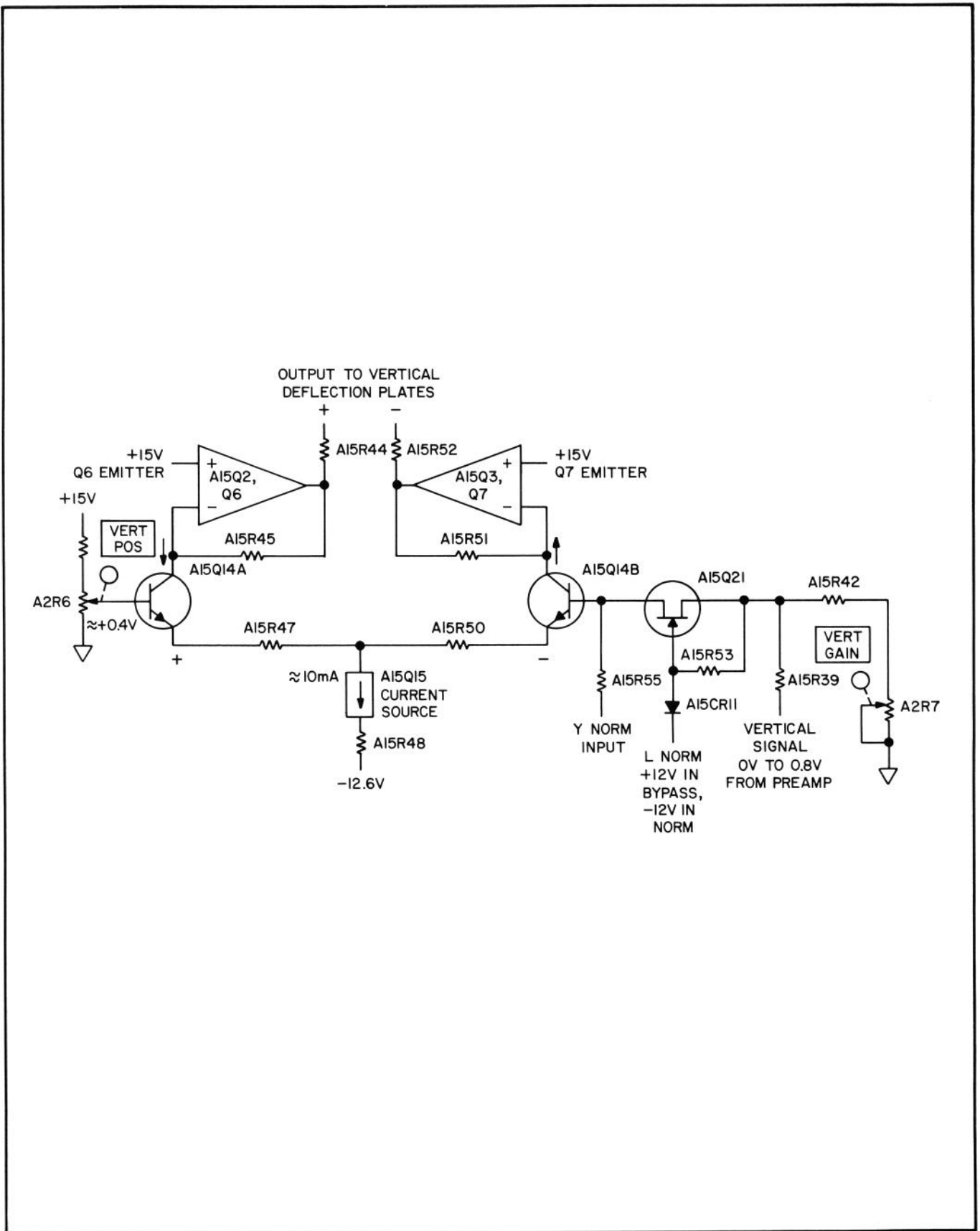

FIGURE 8-55. SIMPLIFIED VERTICAL DRIVER CIRCUIT

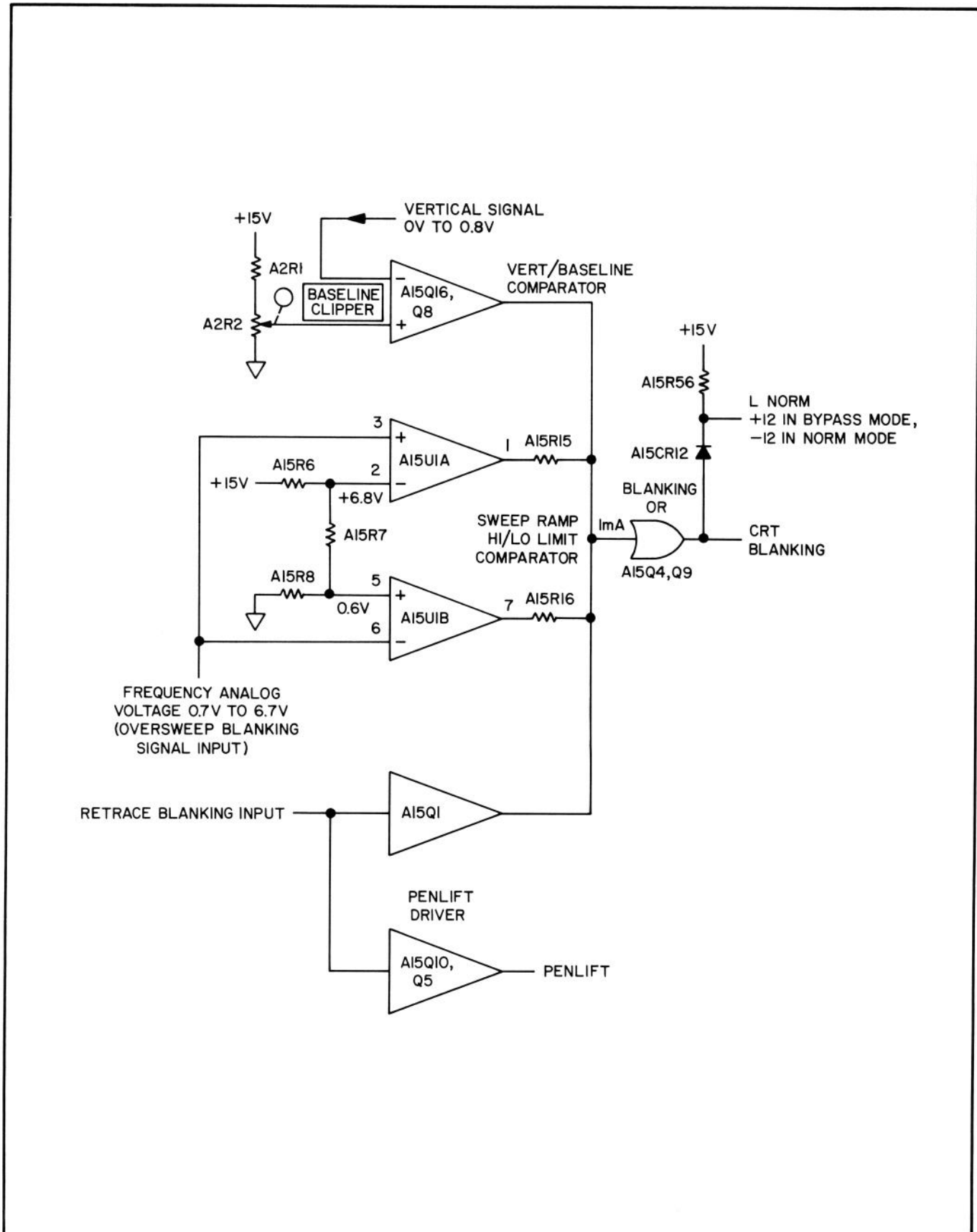

FIGURE 8-56. SIMPLIFIED BLANKING CIRCUIT

TABLE 8-15. A15 VERTICAL DRIVER AND BLANKING ASSEMBLY, REPLACEABLE PARTS (1 OF 2)

Reference Designation	HP Part Number	C D	Qty	Description	Mfr Code	Mfr Part Number
A15	08558-60115	9	1	VERTICAL DRIVE AND BLANKING ASSEMBLY	28480	08558-60115
A15C1	0180-0197	8	4	CAPACITOR-FXD 2.2UF+-10% 20VDC TA	56289	150D225X9020A2
A15C2	0180-0197	8		CAPACITOR-FXD 2.2UF+-10% 20VDC TA	56289	150D225X9020A2
A15C3	0180-0197	8	2	CAPACITOR-FXD 2.2UF+-10% 20VDC TA	56289	150D225X9020A2
A15C4	0160-2055	9		CAPACITOR-FXD .01UF +80-20% 100VDC CER	28480	0160-2055
A15C5	0180-0197	8		CAPACITOR-FXD 2.2UF+-10% 20VDC TA	56289	150D225X9020A2
A15C6	0160-2055	9		CAPACITOR-FXD .01UF +80-20% 100VDC CER	28480	0160-2055
A15CR1	1901-0040	1	7	DIODE-SWITCHING 30V 50MA 2NS DO-35	28480	1901-0040
A15CR2	1901-0040	1		DIODE-SWITCHING 30V 50MA 2NS DO-35	28480	1901-0040
A15CR3	1901-0040	1	1	DIODE-SWITCHING 30V 50MA 2NS DO-35	28480	1901-0040
A15CR4	1901-0535	9		DIODE-SM SIG SCHOTTKY	28480	1901-0535
A15CR5	1901-0040	1		DIODE-SWITCHING 30V 50MA 2NS DO-35	28480	1901-0040
A15CR6	1901-0040	1	3	DIODE-SWITCHING 30V 50MA 2NS DO-35	28480	1901-0040
A15CR7	1901-0040	1		DIODE-SWITCHING 30V 50MA 2NS DO-35	28480	1901-0040
A15CR8	1901-0040	1	3	DIODE-SWITCHING 30V 50MA 2NS DO-35	28480	1901-0040
A15CR9	1901-0050	3		DIODE-SWITCHING 80V 200MA 2NS DO-35	28480	1901-0050
A15CR10	1901-0050	3		DIODE-SWITCHING 80V 200MA 2NS DO-35	28480	1901-0050
A15CR11	1901-0050	3	1	DIODE-SWITCHING 80V 200MA 2NS DO-35	28480	1901-0050
A15CR12	1901-0518	8		DIODE-SM SIG SCHOTTKY	28480	1901-0518
A15L1	9140-0179	1	2	INDUCTOR RF-CH-MLD 22UH 10% .166DX,365LC	28480	9140-0179
A15L2	9140-0179	1		INDUCTOR RF-CH-MLD 22UH 10% .166DX,365LC	28480	9140-0179
A15Q1	1853-0007	7	3	TRANSISTOR PNP 2N3251 SI TO-18 PD=360MW	04713	2N3251
A15Q2	1854-0234	4		TRANSISTOR NPN 2N3440 SI TO-5 PD=1W	3L585	2N3440
A15Q3	1854-0234	4	1	TRANSISTOR NPN 2N3440 SI TO-5 PD=1W	3L585	2N3440
A15Q4	1854-0009	1		TRANSISTOR NPN SI PD=300MW FT=600MHZ	04713	2N739
A15Q5	1854-0404	0	5	TRANSISTOR NPN SI TO-18 PD=360MW	28480	1854-0404
A15Q6	1854-0234	4	4	TRANSISTOR NPN 2N3440 SI TO-5 PD=1W	3L585	2N3440
A15Q7	1854-0234	4		TRANSISTOR NPN 2N3440 SI TO-5 PD=1W	3L585	2N3440
A15Q8	1853-0007	7	7	TRANSISTOR PNP 2N3251 SI TO-18 PD=360MW	04713	2N3251
A15Q9	1854-0019	3		TRANSISTOR NPN SI TO-18 PD=360MW	28480	1854-0019
A15Q10	1854-0039	7	1	TRANSISTOR NPN 2N3053S SI TO-39 PD=1W	3L585	2N3053S
A15Q11	1853-0451	5	2	TRANSISTOR PNP 2N3799 SI TO-18 PD=360MW	01295	2N3799
A15Q12	1853-0451	5		TRANSISTOR PNP 2N3799 SI TO-18 PD=360MW	01295	2N3799
A15Q13	1854-0404	0	1	TRANSISTOR NPN SI TO-18 PD=360MW	28480	1854-0404
A15Q14	1854-0475	5		TRANSISTOR-DUAL NPN PD=750MW	28480	1854-0475
A15Q15	1854-0404	0		TRANSISTOR NPN SI TO-18 PD=360MW	28480	1854-0404
A15Q16	1853-0007	7	7	TRANSISTOR PNP 2N3251 SI TO-18 PD=360MW	04713	2N3251
A15Q17	1855-0376	7		TRANSISTOR-JFET DUAL N-CHAN D-MODE SI	28480	1855-0376
A15Q18	1854-0404	0	1	TRANSISTOR NPN SI TO-18 PD=360MW	28480	1854-0404
A15Q19	1855-0417	7		TRANSISTOR J-FET N-CHAN D-MODE TO-18 SI	28480	1855-0417
A15Q20	1854-0404	0		TRANSISTOR NPN SI TO-18 PD=360MW	28480	1854-0404
A15Q21	1855-0020	8	1	TRANSISTOR J-FET N-CHAN D-MODE TO-18 SI	28480	1855-0020
A15R1	2100-3123	0	1	RESISTOR-TRMR 500 10% C SIDE-ADJ 17-TRN	02111	43P501
A15R2	0757-0199	3		6	RESISTOR 21.5K 1% .125W F TC=0+-100	24546
A15R3	0757-0420	3	2	RESISTOR 750 1% .125W F TC=0+-100	24546	C4-1/8-T0-751-F
A15R4	0757-0280	3		3	RESISTOR 1K 1% .125W F TC=0+-100	24546
A15R5	0757-0279	0	3	RESISTOR 3.16K 1% .125W F TC=0+-100	24546	C4-1/8-T0-3161-F
A15R6	0698-3156	2	4	RESISTOR 14.7K 1% .125W F TC=0+-100	24546	C4-1/8-T0-1472-F
A15R7	0757-0444	1		2	RESISTOR 12.1K 1% .125W F TC=0+-100	24546
A15R8	0757-0424	7	3	RESISTOR 1.1K 1% .125W F TC=0+-100	24546	C4-1/8-T0-1101-F
A15R9	0698-3156	2		RESISTOR 14.7K 1% .125W F TC=0+-100	24546	C4-1/8-T0-1472-F
A15R10	0757-0199	3		RESISTOR 21.5K 1% .125W F TC=0+-100	24546	C4-1/8-T0-2152-F
A15R11	0698-3155	1	3	RESISTOR 4.64K 1% .125W F TC=0+-100	24546	C4-1/8-T0-4641-F
A15R12	0757-0416	7		3	RESISTOR 511 1% .125W F TC=0+-100	24546
A15R13	0683-0475	1	1	RESISTOR 4.7 5% .25W FC TC=-400/+500	01121	CB47G5
A15R14	0757-0424	7		RESISTOR 1.1K 1% .125W F TC=0+-100	24546	C4-1/8-T0-1101-F
A15R15	0757-0199	3		RESISTOR 21.5K 1% .125W F TC=0+-100	24546	C4-1/8-T0-2152-F
A15R16	0757-0199	3	3	RESISTOR 21.5K 1% .125W F TC=0+-100	24546	C4-1/8-T0-2152-F
A15R17	0757-0280	3		RESISTOR 1K 1% .125W F TC=0+-100	24546	C4-1/8-T0-1001-F
A15R18	0698-3155	1	1	RESISTOR 4.64K 1% .125W F TC=0+-100	24546	C4-1/8-T0-4641-F
A15R19	0698-0084	9		RESISTOR 2.15K 1% .125W F TC=0+-100	24546	C4-1/8-T0-2151-F
A15R20	0757-0416	7		RESISTOR 511 1% .125W F TC=0+-100	24546	C4-1/8-T0-511R-F
A15R21	0683-1055	5	1	RESISTOR 1M 5% .25W FC TC=-800/+900	01121	CB1055
A15R22	0757-0442	9		3	RESISTOR 10K 1% .125W F TC=0+-100	24546
A15R23	0757-0465	6	2	RESISTOR 100K 1% .125W F TC=0+-100	24546	C4-1/8-T0-1003-F
A15R24	0757-0442	9		RESISTOR 10K 1% .125W F TC=0+-100	24546	C4-1/8-T0-1002-F
A15R25	0757-0199	3		RESISTOR 21.5K 1% .125W F TC=0+-100	24546	C4-1/8-T0-2152-F
A15R26*	0698-3153	9	1	RESISTOR 3.03K 1% .125W F TC=0+-100	24546	C4-1/8-T0-3031-F
A15R27	0698-3440	7		4	RESISTOR 196 1% .125W F TC=0+-100	24546
A15R28	0698-3440	7	7	RESISTOR 196 1% .125W F TC=0+-100	24546	C4-1/8-T0-196R-F
A15R29	0757-0279	0		RESISTOR 3.16K 1% .125W F TC=0+-100	24546	C4-1/8-T0-3161-F
A15R30	0698-3156	2		RESISTOR 14.7K 1% .125W F TC=0+-100	24546	C4-1/8-T0-1472-F

*Indicates factory selected value

TABLE 8-15. A15 VERTICAL DRIVER AND BLANKING ASSEMBLY, REPLACEABLE PARTS (2 OF 2)

Reference Designation	HP Part Number	C D	Qty	Description	Mfr Code	Mfr Part Number
A15R31	0757-0444	1	4	RESISTOR 12.1K 1% .125W F TC=0+-100	24546	C4-1/8-T0-1212-F
A15R32	0698-3444	1		RESISTOR 316 1% .125W F TC=0+-100	24546	C4-1/8-T0-316R-F
A15R33	0757-0424	7		RESISTOR 1.1K 1% .125W F TC=0+-100	24546	C4-1/8-T0-1101-F
A15R34	0698-3156	2		RESISTOR 14.7K 1% .125W F TC=0+-100	24546	C4-1/8-T0-1472-F
A15R35	0757-0279	0		RESISTOR 3.16K 1% .125W F TC=0+-100	24546	C4-1/8-T0-3161-F
A15R36	0757-0200	7	1	RESISTOR 5.62K 1% .125W F TC=0+-100	24546	C4-1/8-T0-5621-F
A15R37	0757-0465	6		RESISTOR 100K 1% .125W F TC=0+-100	24546	C4-1/8-T0-1003-F
A15R38	0757-0199	3		RESISTOR 21.5K 1% .125W F TC=0+-100	24546	C4-1/8-T0-2152-F
A15R39	0698-3444	1		RESISTOR 316 1% .125W F TC=0+-100	24546	C4-1/8-T0-316R-F
A15R40	0757-0394	0		RESISTOR 51.1 1% .125W F TC=0+-100	24546	C4-1/8-T0-51R1-F
A15R41	0698-3155	1	2	RESISTOR 4.64K 1% .125W F TC=0+-100	24546	C4-1/8-T0-4641-F
A15R42	0757-0416	7		RESISTOR 511 1% .125W F TC=0+-100	24546	C4-1/8-T0-511R-F
A15R43	0757-0442	9		RESISTOR 10K 1% .125W F TC=0+-100	24546	C4-1/8-T0-1002-F
A15R44	0698-3444	1		RESISTOR 316 1% .125W F TC=0+-100	24546	C4-1/8-T0-316R-F
A15R45	0757-0837	6		RESISTOR 8.25K 1% .5W F TC=0+-100	28480	0757-0837
A15R46	0757-0844	5	2	RESISTOR 16.2K 1% .5W F TC=0+-100	28480	0757-0844
A15R47	0698-3440	7		RESISTOR 196 1% .125W F TC=0+-100	24546	C4-1/8-T0-196R-F
A15R48	0757-0426	3		RESISTOR 750 1% .125W F TC=0+-100	24546	C4-1/8-T0-751-F
A15R49	0757-0844	5		RESISTOR 16.2K 1% .5W F TC=0+-100	28480	0757-0844
A15R50	0698-3440	7		RESISTOR 196 1% .125W F TC=0+-100	24546	C4-1/8-T0-196R-F
A15R51	0757-0837	6	1	RESISTOR 8.25K 1% .5W F TC=0+-100	28480	0757-0837
A15R52	0698-3444	1		RESISTOR 316 1% .125W F TC=0+-100	24546	C4-1/8-T0-316R-F
A15R53	0698-3260	9		RESISTOR 464K 1% .125W F TC=0+-100	28480	0698-3260
A15R54	0698-3446	3		RESISTOR 383 1% .125W F TC=0+-100	24546	C4-1/8-T0-383R-F
A15R55	0757-0280	3		RESISTOR 1K 1% .125W F TC=0+-100	24546	C4-1/8-T0-1001-F
A15R56	0698-7284	5	1	RESISTOR 100K 1% .05W F TC=0+-100	24546	C3-1/8-T0-1003-F
A15TP1	1251-0600	0	4	CONNECTOR-SGL CONT PIN 1.14-MM-BSC-SZ SQ	28480	1251-0600
A15TP2	1251-0600	0		CONNECTOR-SGL CONT PIN 1.14-MM-BSC-SZ SQ	28480	1251-0600
A15TP3	1251-0600	0		CONNECTOR-SGL CONT PIN 1.14-MM-BSC-SZ SQ	28480	1251-0600
A15TP4	1251-0600	0		CONNECTOR-SGL CONT PIN 1.14-MM-BSC-SZ SQ	28480	1251-0600
A15U1	1826-0392	3	1	IC OP AMP GP DUAL TO-99 PKG	28480	1826-0392
A15U2	1858-0032	8	1	TRANSISTOR ARRAY 14-PIN PLSTC DIP	3L585	CA3146E
A15VR1	1932-0033	4	1	DIODE-ZNR 1N823 6.2V 5% DD-7 PD=.4W	24346	1N823
A15VR2	1902-0202	9	1	DIODE-ZNR 15V 5% PD=1W IR=50A	28480	1902-0202
A15VR3	1932-0556	6	1	DIODE-ZNR 20V 5% PD=1W IR=50A	28480	1932-0556
				MISCELLANEOUS		
	1200-0173	5	5	INSULATOR-XSTR DAP-CL	28480	1200-0173

*Indicates factory selected value

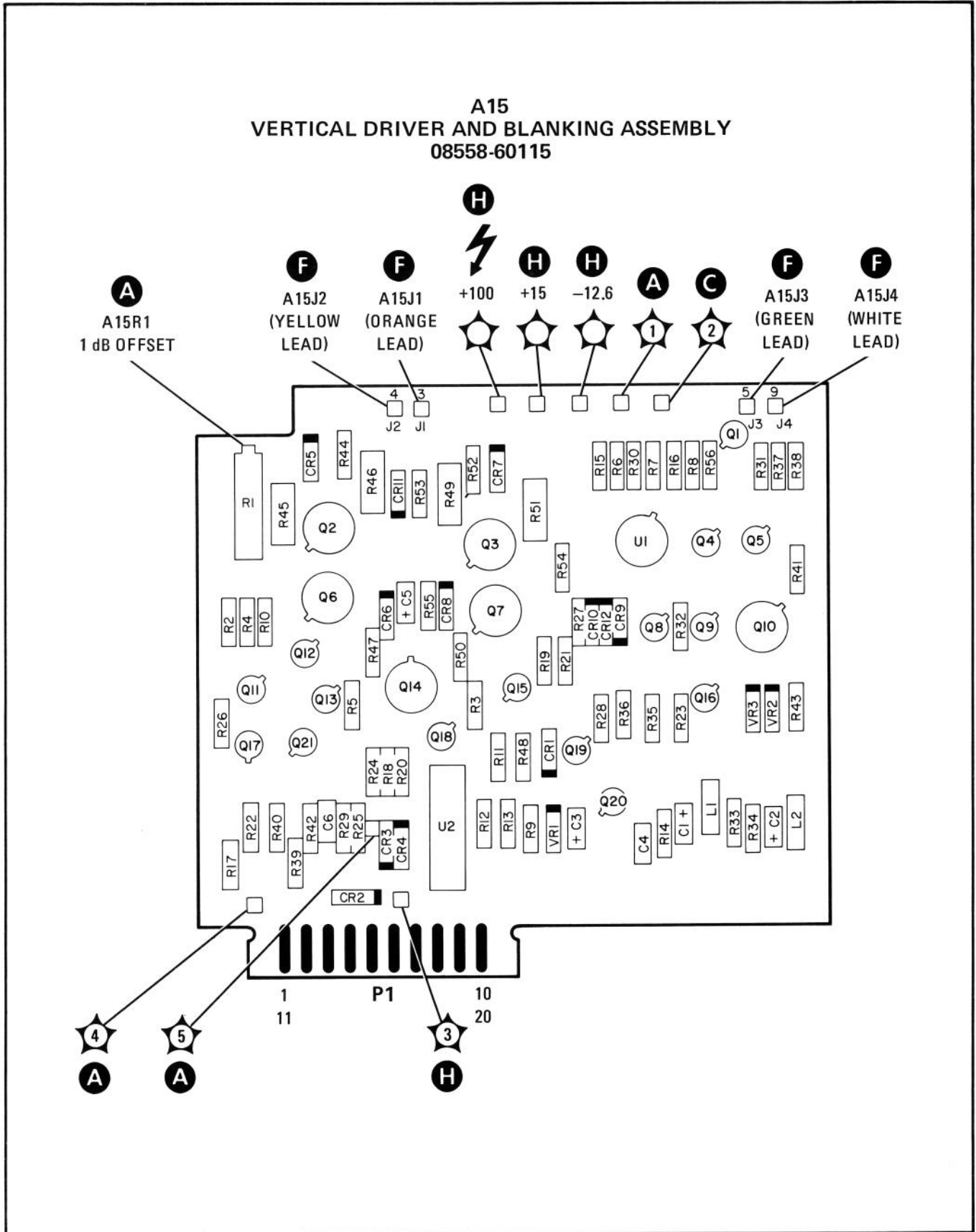

FIGURE 8-57. A15 VERTICAL DRIVER AND BLANKING ASSEMBLY, COMPONENT LOCATIONS

TABLE 8-16. A16 MOTHER BOARD ASSEMBLY, REPLACEABLE PARTS

Reference Designation	HP Part Number	C D	Qty	Description	Mfr Code	Mfr Part Number
A16	08558-60175	1	1	MOTHERBOARD (INCL W12, W13 AND P1)	28480	08558-60175
A16C1	0160-3879	7	5	CAPACITOR-FXD .01UF +-20% 100VDC CER	28480	0160-3879
A16C2	0160-3879	7		CAPACITOR-FXD .01UF +-20% 100VDC CER	28480	0160-3879
A16C3	0160-3879	7		CAPACITOR-FXD .01UF +-20% 100VDC CER	28480	0160-3879
A16C4	0160-3879	7		CAPACITOR-FXD .01UF +-20% 100VDC CER	28480	0160-3879
A16C5	0180-0197	8	2	CAPACITOR-FXD 2.2UF+-10% 20VDC TA	56289	150D225X9020A2
A16C6	0180-0197	8		CAPACITOR-FXD 2.2UF+-10% 20VDC TA	56289	150D225X9020A2
A16C7	0160-3879	7		CAPACITOR-FXD .01UF +-20% 100VDC CER	28480	0160-3879
A16C8	0160-4084	8	1	CAPACITOR-FXD .1UF +-20% 50VDC CER	28480	0160-4084
A16C9	0160-2055	9	6	CAPACITOR-FXD .01UF +80-20% 100VDC CER	28480	0160-2055
A16C10	0160-2055	9		CAPACITOR-FXD .01UF +80-20% 100VDC CER	28480	0160-2055
A16C11	0160-2055	9		CAPACITOR-FXD .01UF +80-20% 100VDC CER	28480	0160-2055
A16C12	0160-2055	9		CAPACITOR-FXD .01UF +80-20% 100VDC CER	28480	0160-2055
A16C13	0160-2055	9		CAPACITOR-FXD .01UF +80-20% 100VDC CER	28480	0160-2055
A16C14	0160-2055	9		CAPACITOR-FXD .01UF +80-20% 100VDC CER	28480	0160-2055
A16CR1	1901-0033	2	1	DIODE-GEN PRP 180V 200MA DO-7	28480	1901-0033
A16CR2	1901-0376	6	1	DIODE-GEN PRP 35V 50MA DO-35	28480	1901-0376
A16CR3	1901-0050	3	1	DIODE-SWITCHING 80V 200MA 2NS DO-35	28480	1901-0050
A16J2	0360-1788	7	1	CONNECTOR-SGL CONT PIN .045-IN-BSC-SZ 5Q	28480	0360-1788
A16L1	9140-0158	6	4	INDUCTOR RF-CH-MLD 1UH 10% .105DX.26LG	28480	9140-0158
A16L2	9140-0158	6		INDUCTOR RF-CH-MLD 1UH 10% .105DX.26LG	28480	9140-0158
A16L3	9140-0158	6		INDUCTOR RF-CH-MLD 1UH 10% .105DX.26LG	28480	9140-0158
A16L4	9140-0158	6		INDUCTOR RF-CH-MLD 1UH 10% .105DX.26LG	28480	9140-0158
A16L5	9100-2247	4	1	INDUCTOR RF-CH-MLD 100NH 10% .105DX.26LG	28480	9100-2247
A16P1W1	08558-60169	3	1	CBL AY REAR R & P	28480	08558-60169
A16R1	0757-0424	7	1	RESISTOR 1.1K 1% .125W F TC=0+-100	24546	C4-1/8-T0-1101-F
A16R2	0757-0465	6	1	RESISTOR 100K 1% .125W F TC=0+-100	24546	C4-1/8-T0-1003-F
A16R3	0698-5368	2	1	RESISTOR 3.74K .25% .125W F TC=0+-50	28480	0698-5368
A16R4	2100-1757	2	1	RESISTOR-TRMR 500 5% WW SIDE-ADJ 1-TRN	28480	2100-1757
A16R5	0757-0444	1	1	RESISTOR 12.1K 1% .125W F TC=0+-100	24546	C4-1/8-T0-1212-F
A16R6	0698-3442	9	1	RESISTOR 237 1% .125W F TC=0+-100	24546	C4-1/8-T0-237R-F
A16R7	0757-0395	1	1	RESISTOR 56.2 1% .125W F TC=0+-100	24546	C4-1/8-T0-56R2-F
A16R8	0698-3260	9	1	RESISTOR 464K 1% .125W F TC=0+-100	28480	0698-3260
A16TP1	1251-0600	0	2	CONNECTOR-SGL CONT PIN 1.14-MM-BSC-SZ 5Q	28480	1251-0600
A16TP2	1251-0600	0		CONNECTOR-SGL CONT PIN 1.14-MM-BSC-SZ 5Q	28480	1251-0600
A16VR1	1902-0625	0	1	DIODE-ZNR 1N829 6.2V 5% DO-7 PD=.25W	04713	1N829
A16VR2	1902-0631	8	1	DIODE-ZNR 1N5351B 14V 5% PD=5W TC=+75%	04713	1N5351B
A16VR3	1902-0632	9	1	DIODE-ZNR 1N5354B 17V 5% PD=5W TC=+75%	04713	1N5354B
A16VR4	1902-3182	0	1	DIODE-ZNR 12.1V 5% DO-35 PD=.4W	28480	1902-3182
A16W1-				NOT ASSIGNED		
A16W11						
A16W12	08558-60044	3	1	CBL AY YIG DRVR	28480	08558-60044
A16W13	08558-60080	7	1	CBL AY 2ND CONV	28480	08558-60080
A16XA7	1251-1365	6	6	CONNECTOR-PC EDGE 22-CONT/ROW 2-ROWS	28480	1251-1365
A16XA8	1251-1365	6		CONNECTOR-PC EDGE 22-CONT/ROW 2-ROWS	28480	1251-1365
A16XA9	1251-0472	4	2	CONNECTOR-PC EDGE 6-CONT/ROW 2-ROWS	28480	1251-0472
A16XA10	1251-0472	4		CONNECTOR-PC EDGE 6-CONT/ROW 2-ROWS	28480	1251-0472
A16XA11	1251-1365	6		CONNECTOR-PC EDGE 22-CONT/ROW 2-ROWS	28480	1251-1365
A16XA12	1251-1365	6		CONNECTOR-PC EDGE 22-CONT/ROW 2-ROWS	28480	1251-1365
A16XA13	1251-1365	6		CONNECTOR-PC EDGE 22-CONT/ROW 2-ROWS	28480	1251-1365
A16XA14	1251-1365	6		CONNECTOR-PC EDGE 22-CONT/ROW 2-ROWS	28480	1251-1365
A16XA15	1251-2034	8	1	CONNECTOR-PC EDGE 10-CONT/ROW 2-ROWS	28480	1251-2034
				MISCELLANEOUS		
	3050-0672	2	1	WASHER-SHLDR NO. 4 .118-IN-ID .25-IN-OD	28480	3050-0672
	0380-0043	5	2	STANDOFF-RVT-ON .125-IN-LC 4-40THD	00000	ORDER BY DESCRIPTION

*Indicates factory selected value

A17 INVERTER, CIRCUIT DESCRIPTION

+ 5V Power Supply

Inverter Assembly A17 is a single transformer inverter with A17Q1 and Q2 operating as a 22 kHz square-wave oscillator. Diodes A17CR1 and CR2 prevent the transistors from base-emitter reverse breakdown. Positive feedback to sustain the oscillation is taken from the transistor base tickler winding of T1. A17R1* provides current to the base of Q2 to start oscillations when the -12.6V supply is first turned on. The voltage at the collectors of A17Q1 and Q2 is a -12V to $+12\text{V}$ square-wave. Diodes A17CR5, CR6, CR7, and CR8 are connected as a full-wave rectifier, receiving ac power from 6V taps on either side of the grounded center tap. The rectified dc is filtered by A17L6, L7, L8, C5, and C6. The filtered output voltage is $+5\text{V}$ and powers DPM Driver Assembly A1A2. A17VR1, a 6.19V zener, provides protection for the DPM Driver in case of excessive or reverse voltage.

+ 20.5V Power Supply

The oscillating current between the collectors of A17Q1 and Q2, through the primary winding of T1, induces a voltage in the secondary of T1. Diodes CR3 and CR4 full-wave rectify this voltage, which is then filtered by A17L3, L4, L5, C3, and C4. The dc output voltage, approximately $+5.5\text{V}$, is added to the $+15\text{V}$ supply to obtain a $+20.5\text{V}$ supply.

TABLE 8-17. A17 INVERTER ASSEMBLY, REPLACEABLE PARTS

Reference Designation	HP Part Number	C D	Qty	Description	Mfr Code	Mfr Part Number
A17	08558-60035 08558-60017	2 0	1 1	INVERTER ASSEMBLY INVERTER ASSEMBLY (INCLUDES MP1, MP2 AND MP3)	28480 28480	08558-60035 08558-60017
A17C1	0180-0228	6	1	CAPACITOR-FXD 22UF+-10% 15VDC TA	56289	150D226X9015B2
A17C2	0180-1747	6	1	CAPACITOR-FXD 150UF+-20% 15VDC TA	56289	150D157X0015
A17C3	0160-0128	3	2	CAPACITOR-FXD 2.2UF +-20% 50VDC CER	28480	0160-0128
A17C4	0180-0229	7	1	CAPACITOR-FXD 33UF+-10% 10VDC TA	56289	150D336X9010B2
A17C5	0160-0128	3	1	CAPACITOR-FXD 2.2UF +-20% 50VDC CER	28480	0160-0128
A17C6	0180-1714	7	1	CAPACITOR-FXD 330UF+-10% 6VDC TA	56289	150D337X9006S2
A17CR1	1901-0620	3	8	DIODE-SWITCHING 60V 400MA DO-35	9N171	NDP250
A17CR2	1901-0620	3		DIODE-SWITCHING 60V 400MA DO-35	9N171	NDP250
A17CR3	1901-0620	3		DIODE-SWITCHING 60V 400MA DO-35	9N171	NDP250
A17CR4	1901-0620	3		DIODE-SWITCHING 60V 400MA DO-35	9N171	NDP250
A17CR5	1901-0620	3		DIODE-SWITCHING 60V 400MA DO-35	9N171	NDP250
A17CR6	1901-0620	3		DIODE-SWITCHING 60V 400MA DO-35	9N171	NDP250
A17CR7	1901-0620	3		DIODE-SWITCHING 60V 400MA DO-35	9N171	NDP250
A17CR8	1901-0620	3		DIODE-SWITCHING 60V 400MA DO-35	9N171	NDP250
A17L1	9100-2552	4	3	INDUCTOR RF-CH-MLD 15UH 10% .161DX.385LG	28480	9100-2552
A17L2	08558-80010	5	1	FIL COIL CRANGE	28480	08558-80010
A17L3	9100-1618	1	1	INDUCTOR RF-CH-MLD 5.6UH 10%	28480	9100-1618
A17L4	9100-2552	4		INDUCTOR RF-CH-MLD 15UH 10% .161DX.385LG	28480	9100-2552
A17L5	9100-2552	4		INDUCTOR RF-CH-MLD 15UH 10% .161DX.385LG	28480	9100-2552
A17L6	9140-0096	1	1	INDUCTOR RF-CH-MLD 1UH 10% .166DX.365LG	28480	9140-0096
A17L7	08558-80007	0	2	FIL COIL GREEN	28480	08558-80007
A17L8	08558-80007	0		FIL COIL GREEN	28480	08558-80007
A17Q1	1854-0637	1	2	TRANSISTOR NPN 2N2219A SI TO-5 PD=800MW	01295	2N2219A
A17Q2	1854-0637	1		TRANSISTOR NPN 2N2219A SI TO-5 PD=800MW	01295	2N2219A
A17R1*	0757-0459	8	1	RESISTOR 56.2K 1% .125W F TC=0+-100	24546	C4-1/8-T0-5622-F
A17R2	0757-0180	2	1	RESISTOR 31.6 1% .125W F TC=0+-100	28480	0757-0180
A17T1	08558-80006	9	1	INVERTER XFMR	28480	08558-80006
A17VR1	1902-0551	1	1	DIODE-ZNR 6.2V 5% PD=1W IR=10UA	28480	1902-0551
				MISCELLANEOUS		
	0380-0516	9	2	STANDOFF-RVT-ON .562-IN-LG 4-40THD	00000	ORDER BY DESCRIPTION
	1200-0173	5	1	INSULATOR-XSTR DAP-CL	28480	1200-0173
A17MP3	08558-00049	2	1	INS INVERTER	28480	08558-00049
A17MP1	7100-0529	9	1	COVER: 3.323-IN LG: 1.512-IN W: 0.188-IN	28480	7100-0529
A17MP2	7100-0530	2	1	CAN: 3.369-IN-LG: 1.556-IN W: 0.65-IN DP	28480	7100-0530

*Indicates factory selected value

A17
INVERTER ASSEMBLY
08558-60035

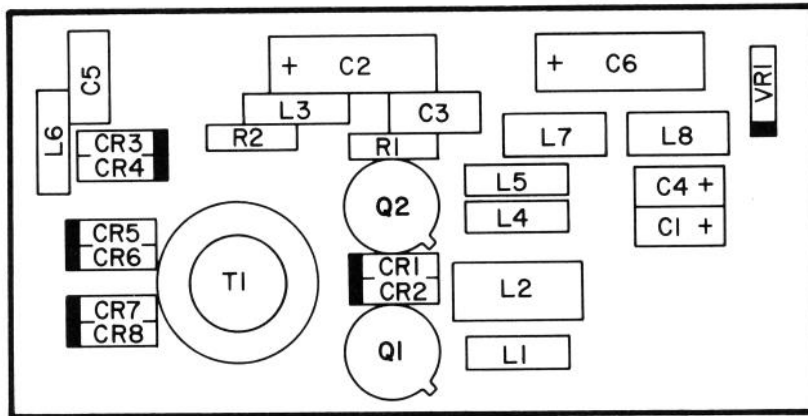
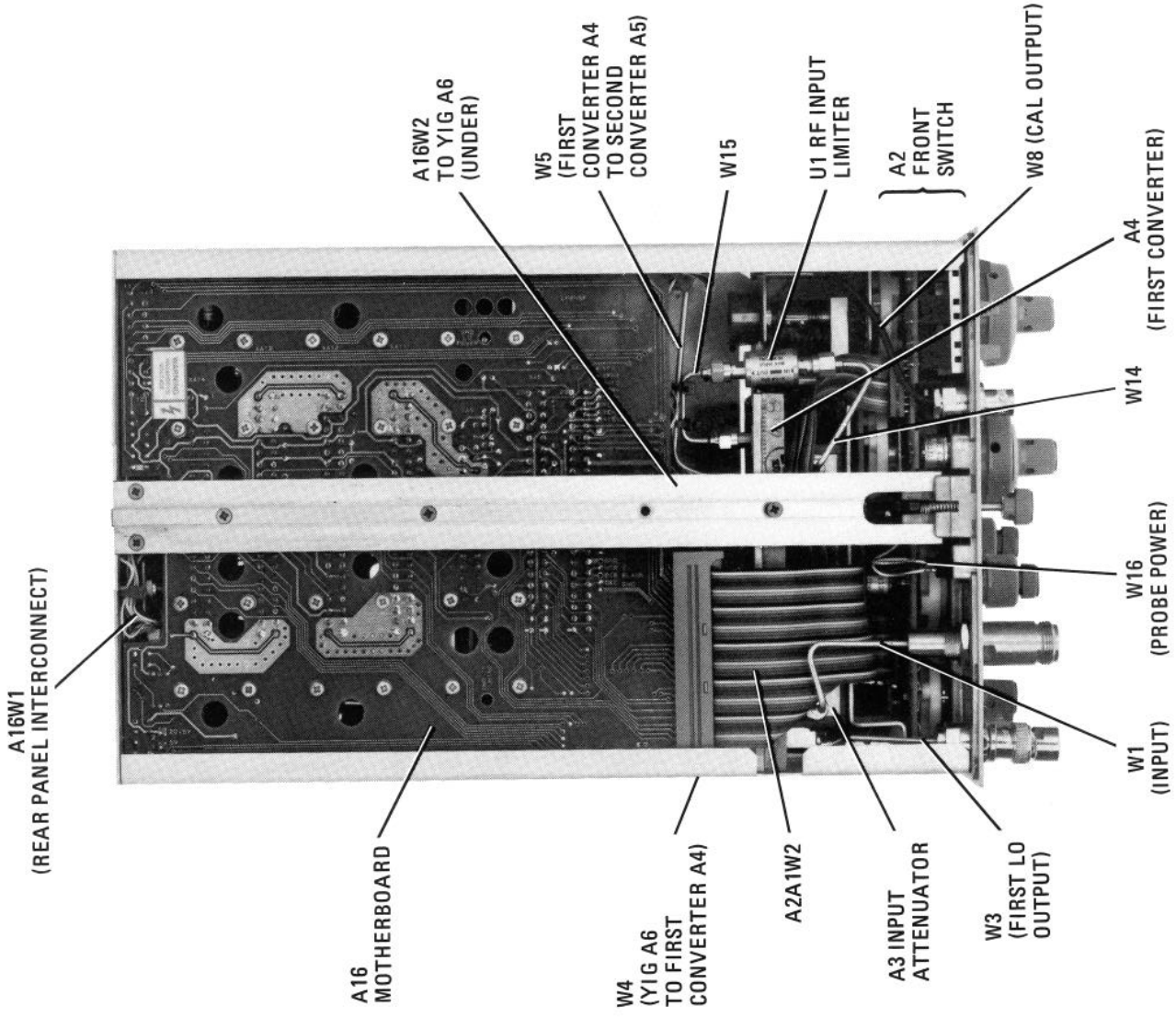

FIGURE 8-61. A17 INVERTER ASSEMBLY, COMPONENT LOCATIONS

BOTTOM VIEW



TOP VIEW

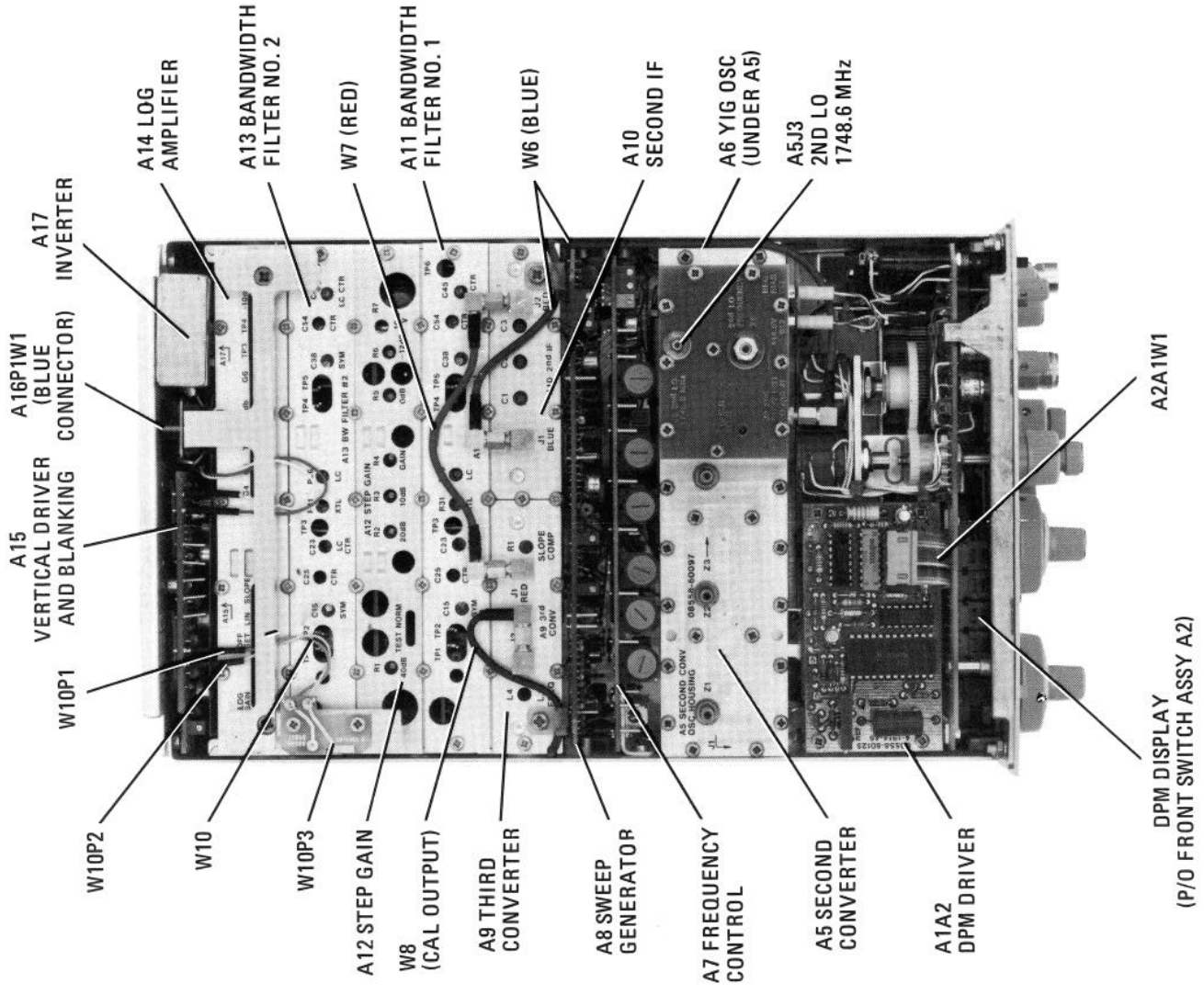

FIGURE 8-63. MAJOR ASSEMBLY AND COMPONENT LOCATIONS
8-165J/8-166

S E R V I C E N O T E

SUPERSEDES:
8558B-13

HP MODEL 8558B SPECTRUM ANALYZER
Serials Prefixed 1612A and Below
TWO POT GEAR DRIVE TUNING MODIFICATION

This modification replaces the dual concentric tuning pots, R1/R2, with two separate pots and a gear drive assembly.

Refer to Figures 6-3 and 7-5 (change D) Front Panel Assembly, Pages 6-29 and 7-7, in 8558B Operating and Service Manual, HP 08558-90043, dated October 1977 and Figure 1. Two Pot Gear Drive Tuning Assembly of this Service Note.

28558 -

JRB/ss/WN

2/79-45



FOR MORE INFORMATION, CALL YOUR LOCAL HP SALES OR SERVICE OFFICE or East (201) 265-5000 • Midwest (312) 255-9800 • South (404) 955-1500 • West (213) 970-7500 or (415) 968-9200 OR WRITE, Hewlett-Packard, 1820 Embarcadero, Palo Alto, California 94303. IN EUROPE, CALL YOUR LOCAL HP SALES or SERVICE OFFICE OR WRITE, Hewlett-Packard S.A., 7, rue du Bois-du-Lan, P.O. Box, CH-1217 Meyrin 2 - Geneva, Switzerland. IN JAPAN, Yokogawa-Hewlett-Packard Ltd., 1-27-15, Yabe Sagamiara City, Kanagawa Prefecture, Japan 229.

PROCEDURE FOR TUNING MODIFICATION:**REMOVING OLD TUNE POTS**

1. Remove A7 Frequency Control Assembly and A8 Sweep Generator Assembly from 8558B.
2. Remove two single wires, (912) and (917) , from front right side of A5 Second Converter.
3. Remove W6 blue coax cable from A5J2 (2nd CONV OUT connector) using 5/16" open-end wrench.
4. Turn 8558B upside down and remove W5 from A5J1 using 5/16" open-end wrench (accessible through hole in side panel, right-hand side).
5. Remove W9P1 (ribbon cable connector) from A16J1 on Master board and pull it up out of the way.
6. Remove W4 from A4 First Converter L0 IN connector using 5/16" open-end wrench (accessible through hole in side panel, left-hand side).
7. Turn 8558B right side up and remove two screws that secure A5 Second Converter to left side panel. Remove two screws from top right-hand side of A5 Second Converter.
8. Carefully remove A5 Second Converter Assembly far enough to disconnect the plug (W12P1) from A6 YIG Oscillator. Remove A5 Second Converter with A6 YIG Oscillator attached to it.
9. Disconnect A1 DPM and remove DPM by removing metal retaining clip.
10. Remove fine TUNING knob using number 4 (.050 inch) Allen driver and remove coarse TUNING knob using number 6 (.062 inch) Allen driver.
11. Clip tie wrap on leads from tune pots and separate wire harness which goes to REF LEVEL FINE pot. Clip five wires from old tune pots (DO NOT remove clipped wires from A2 Front Switch Assembly).
12. Remove brass bushing (looks like hex nut) from TUNING shaft on front panel.
13. Remove long hex nut (81) from old tune pots. Discard old tune pots but save long hex nut (used in dual tune pot assembly).

08558-60091
1612A + below
100 45-00988

WIRING DIAGRAM

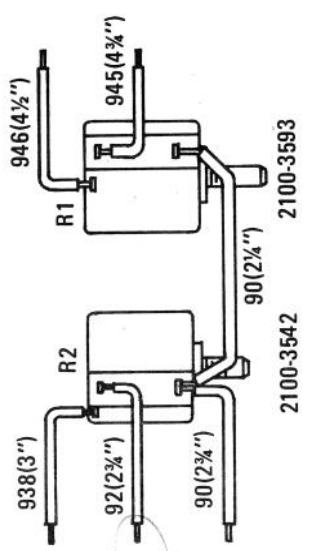

08558-90088
heavy gauge + 6" + terminal

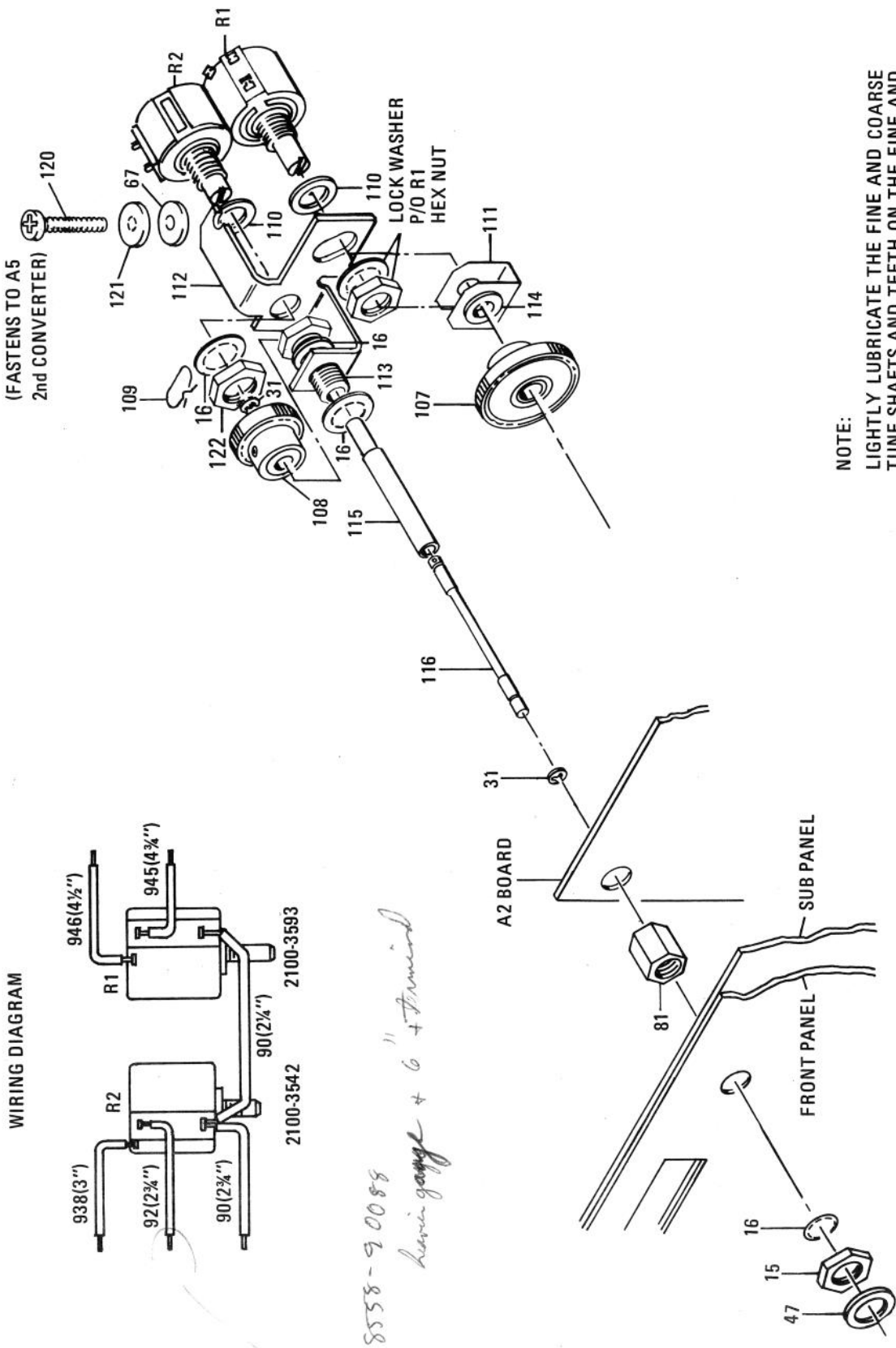

NOTE:
LIGHTLY LUBRICATE THE FINE AND COARSE
TUNE SHAFTS AND TEETH ON THE FINE AND
COARSE TUNE GEARS WITH LUBRICANT,
HP 6040-0018.

Figure 1. Two Pot Gear Drive Tuning Assembly

Table 1. Two Pot Tuning Modification Kit, HP 08558-60091

Quantity	Description	HP Part Number
1	WASHER, FLAT	3050-0105
1	WASHER, LOCK	2190-0004
1	SCREW, MACHINE	2200-0121
1	SHAFT, FINE TUNE	08558-20114
1	SHAFT, COARSE TUNE	08558-20113
1	WASHER, THRUST	08558-20112
1	BUSHING, COARSE TUNE SHAFT	08558-20111
1	BRACKET, DUAL POT	08558-00070
1	SPRING	08558-00069
2	WASHER, FLAT	3050-0086
1	WASHER, FLAT	3050-0017
1	HEX NUT, DOUBLE CHAM, 1/2 INCH OD	2950-0001
1	HEX NUT, DOUBLE CHAM, 7/16 INCH OD	2950-0043
4	WASHER, LOCK	2190-0016
1	COARSE TUNE POT	2100-3593
1	FINE TUNE POT	2100-3452
1	SPRING, UNIVERSAL COUPLER	1460-1542
1	GEAR, SPUR 40-TOOTH	1430-0568
1	GEAR, SPUR 60-TOOTH	1430-0567
2	CLIP, RETAINING	0510-0015
	LUBRICANT (LIGHT GREASE)	6040-0018
1	SERVICE NOTE	8558B-13A
Quantity	Miscellaneous	
1	WIRE, WHITE/ORANGE/GRAY (938) 3 INCHES LONG	
1	WIRE, WHITE/RED (92) 2-3/4 INCHES LONG	
1	WIRE, WHITE/BLACK (90) 2-3/4 INCHES LONG	
1	WIRE, WHITE/BLACK (90) 2-1/4 INCHES LONG	
1	WIRE, WHITE/YELLOW/GREEN (945) 4-3/4 INCHES LONG	
1	WIRE, WHITE/YELLOW/BLUE (946) 4-1/2 INCHES LONG	

ASSEMBLING DUAL TUNE POT ASSEMBLY

14. Refer to Figure 1. Two Pot Gear Drive Tuning Assembly for parts breakdown of tuning assembly, place lock washer (16) on coarse tune shaft bushing (113) and place coarse tune shaft bushing (113) through proper hole in dual pot bracket (112).
15. Place lock washer (16) over coarse tune shaft bushing (113) on front side of dual pot bracket (112).
16. Place long hex nut (81), removed in step 13, on coarse tune bushing (113) and tighten with fingers only.
17. Lightly lubricate fine tune shaft (116) and coarse tune shaft (115) with suggested lubricant (HP Part Number 6040-0018) or a light grease.

18. Place retaining clip (31) in groove on fine tune shaft (116) near end without hole. Insert fine tune shaft (116) into coarse tune shaft (115) from larger diameter end of coarse tune shaft (115).
19. Insert dual shaft assembly (115/116) through threaded end of coarse tune shaft bushing (113).
20. Place 40-tooth spur gear (108) over end of coarse tune shaft (115). With 40-tooth spur gear (108) held as far as it will go on coarse tune shaft (115), tighten set screw in gear with number 4 (.050 inch) Allen driver.
21. Place retaining clip (31) in groove on fine tune shaft (116) near end of shaft with small hole.
22. Insert straight end of universal coupler spring (109) in small hole near end of fine tune shaft (116) and snap universal coupler spring (109) into place.
23. Place flat washer (110) over shaft of fine tune pot R2 (short shaft). Make sure flat washer (110) is seated tightly over collar near body of fine tune pot.
24. Insert fine tune pot R2 through round hole in rear side of dual pot bracket (112) and place lock washer (16) and 1/2 inch OD hex nut (122) over shaft of fine tune pot.
25. Position fine tune pot R2 so the two in-line terminals are lined up with top left corner of dual pot bracket (112). Tighten hex nut (122) on shaft of fine tune pot.
26. Loosen set screw in 40-tooth spur gear (108) using number 4 (.050 inch) Allen driver. Back shaft assembly out slightly and place universal coupler spring (109) in slot of shaft on fine tune pot R2.
27. Exerting slight pressure on front of shaft assembly to properly seat universal coupler spring (109), slide 40-tooth spur gear (108) against hex part of coarse tune shaft bushing (113) and tighten set screw in gear. DO NOT compress coupler. A slight amount of end play in shaft assembly should remain.
28. Remove hex nut and lock washer from coarse tune pot R1 and place flat washer (110) over shaft of coarse tune pot R1. Make sure flat washer (110) is seated tightly over collar near body of coarse tune pot.
29. Insert coarse tune pot through elongated hole in dual pot bracket (112). Place spring (111), with lock washer and hex nut (removed in previous step) in center of spring (111), over shaft of coarse tune pot R1. Tighten hex nut finger tight only.
30. Place thrust washer (114) over shaft of coarse tune pot R1 and seat thrust washer (114) in spring (111).
31. Place 60-tooth spur gear (107) over shaft of coarse tune pot R1. Align teeth of 60-tooth spur gear (107) with teeth of 40-tooth spur gear (108) and tighten set screw in 60-tooth spur gear (107) using number 6 (.062 inch) Allen driver.
32. Position coarse tune pot R1 so the two in-line terminals are lined up with top right corner of dual pot bracket (112). Adjust coarse tune pot R1 (in elongated hole in bracket) so the two spur gears (107/108) are meshed and slight amount of backlash is noted when coarse tune shaft (115) is turned.
33. Making sure that bottom edge of spring (111) is aligned with bottom edge of dual pot bracket (112), tighten hex nut on shaft of coarse tune pot.

34. Solder wires to terminals of tune pots referring to wiring diagram on large illustrated parts breakdown. Dress wires from coarse tune pot R1 underneath rear tab of dual pot bracket (between tab and fine tune pot R2).

INSTALLING DUAL TUNE POT ASSEMBLY

35. Remove long hex nut (81) leaving lock washer (16) in place on coarse tune shaft bushing (113) of dual pot assembly.
36. Stand 8558B on its rear panel so front panel is up and top of instrument is facing you.
37. Place lock washer (16) and long hex nut (81) between A2 Front Switch PC board and front panel. Place shaft of dual tune pot assembly through rear side of A2 Front Switch PC board and tighten long hex nut (81) with edge of dual pot bracket aligned with edge of A2 Front Panel PC board.
38. Remove clipped wires one at a time from A2 Front Switch PC board, replacing each one with the same color wire from the dual tune pot assembly.
39. Dress wire harness from REF LEVEL FINE pot along with leads of dual tune pot assembly. Use two tie wraps to secure bundle of wires.
40. Place lock washer (16) and hex nut (15) over end of TUNING shaft and tighten to front panel. Place flat washer (47) over end of TUNING shaft. Place coarse tune (large) knob on TUNING shaft and tighten both set screws using number 6 (.062 inch) Allen driver.
41. Place fine tune knob on TUNING shaft. Lift fine tune knob slightly to avoid contact with coarse tune knob and tighten both set screws using number 4 (.050 inch) Allen driver.
42. Replace A1 DPM (align two top corner holes in A1 DPM over front panel studs) and secure with metal clip (secure end of metal clip in side panel first, then at center of front panel). Push metal clip down and center over foam cushion. Reconnect DPM.
43. Place A5 Second Converter (with A6 YIG Oscillator attached) into 8558B in the A7/A8 Assemblies position and reconnect the plug (W12P1) to A6 YIG oscillator.
44. Remove screw closest to A5J2 from small top cover of A5 Second Converter Assembly. Carefully maneuver A5 Second Converter Assembly so top of assembly slides under tab of dual tune pot assembly and plug connected to YIG (W12P1) slides under the semi-rigid cable (W5).
45. Reconnect W5 to A5J1 using 5/16" open-end wrench. Reconnect W4 to A4 First Converter L0 IN connector.
46. Replace two flat head screws in side frame (left side) to secure A5 Second Converter.
47. Replace two long screws through top of A5 Second Converter (right side) to secure right side of A5 Second Converter.
48. Place lock washer (121), then flat washer (67) over long 4-40 screw (120) and install, securing dual pot bracket (112) to A5 Second Converter. Tighten screw snugly but do not overtighten.
49. Reconnect (917) and (912) wires to respective terminals on front right side of A5 Second Converter.
50. Reconnect blue coax cable W6 to A5J2 (dress blue cable under (917) and (912) wires).

51. Turn coarse tune knob and check for smoothness of operation with minimum backlash. If necessary, slightly loosen hex nut that secures coarse tune pot R1 and reposition coarse tune pot for optimum mechanical performance of coarse TUNING control. Carefully tighten hex nut securing coarse tune pot.
52. Reinstall A7 Frequency Control Assembly and A8 Sweep Generator Assembly. Reconnect ribbon cable W9P1 to A16J1 on Master Board.
53. Install 8558B in 180-Series mainframe and perform Operator's Check in Section III of Operating and Service Manual.
54. Perform Digital Frequency Readout Accuracy Test, paragraph 4-12, in Operating and Service Manual. If instrument does not meet specification, perform adjustments in paragraphs 5-28, 5-29, and 5-30, Section V of 8558B Operating and Service Manual, HP 08558-90043, dated October 1977.