

# KS8400B Introduction with SL1200A Grid Integration and Compliance Test Automation Suite

SL1200A Grid Integration and Compliance Test Automation Suite includes SL1220A AC/Grid Test Sequencing Plugin and SL1221A PHIL-based Anti-Islanding Compliance Test Automation Plugin

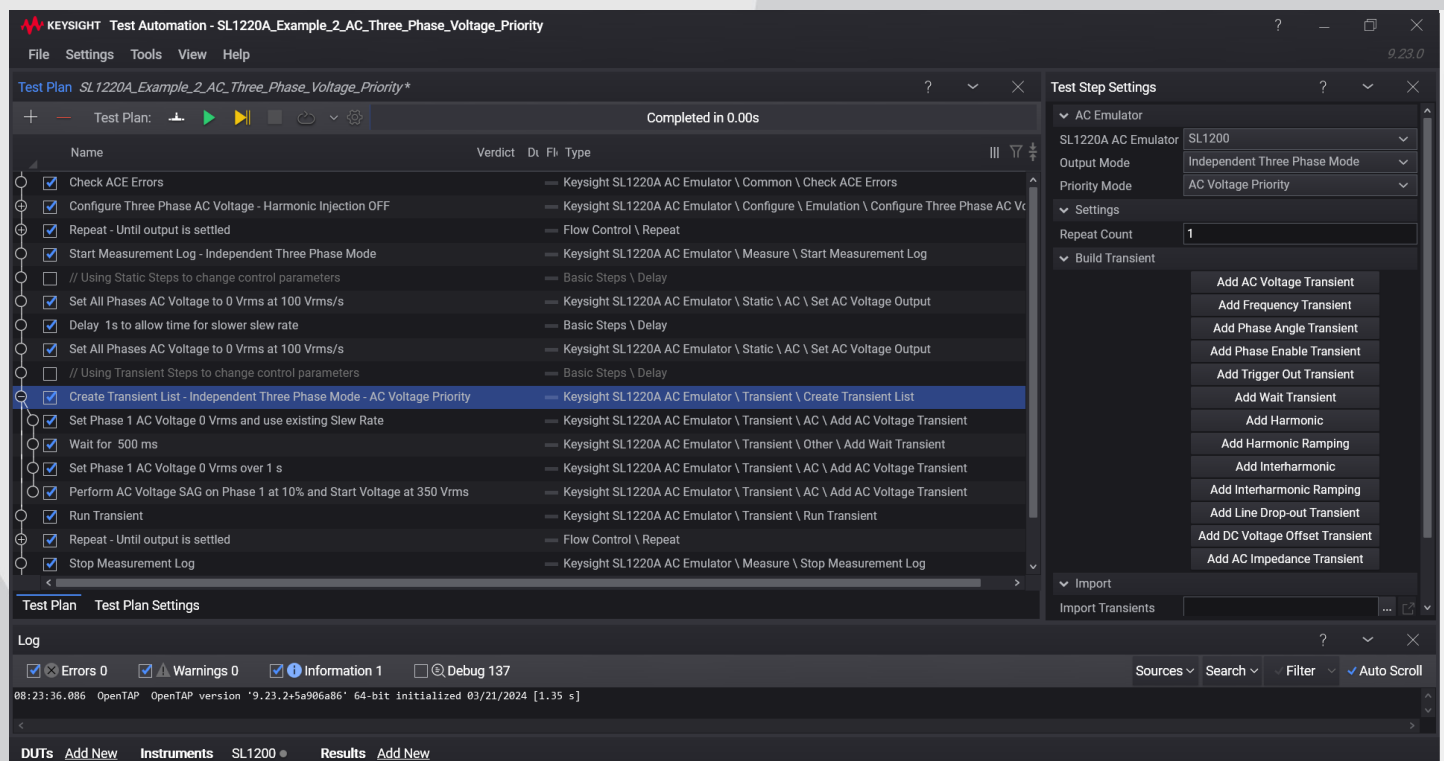

Provides detailed information to configure and use the KS8400B Test Automation software version 9.28.0 (release date 2025-04-14) and later. It also provides installation, use, configuration, and examples for SL1220A and SL1221A Plugins, version 3.1.0 (2025-05-21)

# Notices

© Keysight Technologies, Inc. 2024, 2025

No part of this manual may be reproduced in any form or by any means (including electronic storage and retrieval or translation into a foreign language) without prior agreement and written consent from Keysight Technologies, Inc. as governed by United States and international copyright laws.

## Edition

Second Edition, September 2025

Printed in USA

Keysight Technologies, Inc.  
1400 Fountaingrove Parkway  
Santa Rosa, CA, 95403, USA

## Sales and Technical Support

To contact Keysight for sales and technical support, refer to the support links on the following Keysight websites:

[www.keysight.com/find/SL1200A](http://www.keysight.com/find/SL1200A)

(product-specific information and support, software and documentation updates)

[www.keysight.com/find/assist](http://www.keysight.com/find/assist) (world-wide contact information for repair and service)

You can contact Keysight for warranty, service, or technical support.

- In the United States: 800 829 4844
- In Europe: 31 20 547 9999
- In Japan: 81 426 56 7832

If you find a Keysight product or solution is impacted by a cyber security issue, please report it using this link: [Report a Product Cyber Security issue | Keysight](#).

## Declaration of Conformity

Declarations of Conformity for this product and for other Keysight products may be downloaded from the Web. Go to <http://keysight.com/go/conformity> and click on "Declarations of Conformity." You can then search by product number to find the latest Declaration of Conformity.

## Technology Licenses

The hardware and/or software described in this document are furnished under a license and may be used or copied only in accordance with the terms of such license.

## Third Party Licenses

Copyright (c) 2001, 2002 Swedish Institute of Computer Science.  
All rights reserved.

Redistribution and use in source and binary forms, with or without modification are permitted provided that the following conditions are met:

1. Redistributions of source code must retain the above copyright notice, this list of conditions and the following disclaimer.
2. Redistributions in binary form must reproduce the above copyright notice this list of conditions and the following disclaimer in the documentation and/or other materials provided with the distribution.
3. The name of the author may not be used to endorse or promote products derived from this software without specific prior written permission.

THIS SOFTWARE IS PROVIDED BY THE AUTHOR "AS IS" AND ANY EXPRESS OR IMPLIED WARRANTIES, INCLUDING, BUT NOT LIMITED TO, THE IMPLIED WARRANTIES OF MERCHANTABILITY AND FITNESS FOR A PARTICULAR PURPOSE ARE DISCLAIMED. IN NO EVENT SHALL THE AUTHOR BE LIABLE FOR ANY DIRECT, INDIRECT, INCIDENTAL, SPECIAL EXEMPLARY, OR CONSEQUENTIAL DAMAGES (INCLUDING, BUT NOT LIMITED TO, OF SUBSTITUTE GOODS OR SERVICES; LOSS OF USE, DATA, OR PROFITS; OR BUSINESS INTERRUPTION) HOWEVER CAUSED AND ON ANY THEORY OF LIABILITY, WHETHER IN CONTRACT, STRICT LIABILITY, OR TORT (INCLUDING NEGLIGENCE OR OTHERWISE) ARISING IN ANY WAY OUT OF THE USE OF THIS SOFTWARE, EVEN IF ADVISED OF THE POSSIBILITY OF SUCH DAMAGE.

This file is part of the lwIP TCP/IP stack

## Warranty

THE MATERIAL CONTAINED IN THIS DOCUMENT IS PROVIDED "AS IS," AND IS SUBJECT TO BEING CHANGED, WITHOUT NOTICE, IN FUTURE EDITIONS. FURTHER, TO THE MAXIMUM EXTENT PERMITTED BY APPLICABLE LAW, KEYSIGHT DISCLAIMS ALL WARRANTIES, EITHER EXPRESS OR IMPLIED, WITH REGARD TO THIS MANUAL AND ANY INFORMATION CONTAINED HEREIN, INCLUDING BUT NOT LIMITED TO THE IMPLIED WARRANTIES OF MERCHANTABILITY AND FITNESS FOR A PARTICULAR PURPOSE. KEYSIGHT SHALL NOT BE LIABLE FOR ERRORS OR FOR INCIDENTAL OR CONSEQUENTIAL DAMAGES IN CONNECTION WITH THE FURNISHING, USE, OR PERFORMANCE OF THIS DOCUMENT OR OF ANY INFORMATION CONTAINED HEREIN. SHOULD KEYSIGHT AND THE USER HAVE A SEPARATE WRITTEN AGREEMENT WITH WARRANTY TERMS COVERING THE MATERIAL IN THIS DOCUMENT THAT CONFLICT WITH THESE TERMS, THE WARRANTY TERMS IN THE SEPARATE AGREEMENT SHALL CONTROL.

Keysight Technologies does not warrant third-party system-level (combination of chassis, controllers, modules, etc.) performance, safety, or regulatory compliance unless specifically stated.

## DFARS/Restricted Rights Notices

If software is for use in the performance of a U.S. Government prime contract or subcontract, Software is delivered and licensed as "Commercial computer software" as defined in DFAR 252.227-7014 (June 1995), or as a "commercial item" as defined in FAR 2.101(a) or as "Restricted computer software" as defined in FAR 52.227-19 (June 1987) or any equivalent agency regulation or contract clause. Use, duplication or disclosure of Software is subject to Keysight Technologies' standard commercial license terms, and non-DOD Departments and Agencies of the U.S. Government will receive no greater than Restricted Rights as defined in FAR 52.227-19(c)(1-2) (June 1987). U.S. Government users will receive no greater than Limited Rights as defined in FAR 52.227-14 (June 1987) or DFAR 252.227-7015 (b)(2) (November 1995), as applicable in any technical data.

# Contents

## KS8400B PathWave Test Automation Overview

Objectives . . . . .	7
PathWave Test Automation Software . . . . .	7
Additional Keysight Test Automation Platform (TAP) Resources . . . . .	8
Definition of Terms . . . . .	9

## 1 Install KS8400B Test Automation

Installation . . . . .	12
Start the Test Automation Editor . . . . .	13
Introduction to the Test Automation Editor . . . . .	14
Editor Panels . . . . .	15
Menu and Resource Bars . . . . .	15
Dockable Panels . . . . .	15
Create a Simple Test Plan . . . . .	16
Congratulations! You have just run your first test plan! . . . . .	18

## 2 Demonstration Example

Install the Demonstration Package . . . . .	20
Construct the Test Plan . . . . .	21
Use the Results Viewer and Run Explorer . . . . .	25
Timing Analyzer . . . . .	31
Saving Test Plans . . . . .	33
Optional: Add a Title to Your Test Plan . . . . .	33
This Completes the Exercises on the Editor . . . . .	33

## 3 SL1220A /SL1221A Plugin Installation

SL1200A Package Installation . . . . .	36
SL1200A Package Installation Requirements . . . . .	36
Install the Python Run-Time Environment . . . . .	36
Install Keysight's IO Libraries Suite . . . . .	38
Install SL1200A Grid Integration and Compliance Test Automation Suite . . . . .	39

## 4 Using the SL1220A AC/Grid Test Sequencing Plugin

Equipment and Software Requirements . . . . .	42
Hardware Requirements . . . . .	42
Soft Front Panel . . . . .	43

Software Requirements . . . . .	43
SL1220A Programming Overview . . . . .	44
Add SL1200A System Instruments . . . . .	45
Create the Example Test Plan . . . . .	47
Additional SL1220A Example TAP Programs . . . . .	53

## 5 Using the SL1221A PHIL-based Anti-Islanding Compliance Test Automation Plugin

Equipment and Software Requirements . . . . .	56
Hardware Requirements . . . . .	56
Software Requirements . . . . .	56
Keysight Unintentional Islanding Overview . . . . .	57
An Example Test System for Unintentional Island Tests . . . . .	58
Recommended LAN Configuration . . . . .	59
Steps to Creating an Unintentional Island Test Plan: . . . . .	60
Add and Configure EUT and Test Instruments . . . . .	61
Add a Power Inverter (EUT) . . . . .	61
Add an AC Grid Emulator and DC Source . . . . .	62
Add an AC Grid Emulator . . . . .	63
Add a DC Source . . . . .	64
Optional: Add EUT Nameplate Information . . . . .	66
IEEE 1547.1-2020 Conformance Step . . . . .	67
Grid Emulator, EUT, and DC Source . . . . .	68
Create the Test Plan . . . . .	69
Nameplate Test Step . . . . .	70
Section 5.10 Unintentional Island Test Steps . . . . .	71
Section 5.10 Measure Sustained Island Test Step . . . . .	72
Section 5.10 Measure Clearing Time Test Step . . . . .	73
Status Panel . . . . .	74
Running a Test Plan . . . . .	75
Running a Measure Sustained Island Step . . . . .	75
Running a Measure Clearing Time Step . . . . .	78
Measurements and Post Processing Directories . . . . .	82
CSV Measurement Files . . . . .	83
PNG Waveform Files . . . . .	85

### A Additional TAP Functions

Color Theme . . . . .	87
Locking a Test Plan . . . . .	88
Unlocking a Test Plan . . . . .	89
Run Time Estimation . . . . .	90
Overview . . . . .	90

Usage .....	90
Run Your Test Plan.....	92
Additional Notes .....	93
Run Explorer .....	93
Editor Settings .....	94
Test Plan Estimation Capturing .....	94



# KS8400B PathWave Test Automation Overview

Welcome to the Keysight 8400B PathWave Test Automation Getting Started Guide. In this chapter, you learn how to use the simple graphical user interface for PathWave Test Automation, called the Editor. Let's get started.

## Objectives

In this guide you will learn how to:

- Obtain and install KS8400B PathWave Test Automation Platform license
- Obtain and install SL1220A and SL1221A Plugins and licenses
- Navigate the *PathWave Test Automation Platform (TAP) Editor*
- Create a simple *test plan* and *configure test steps*
- Add and configure *resources: Instruments, Devices Under Test (DUTs), and Result Listeners*

## PathWave Test Automation Software

For information about Keysight PathWave Test Automation, go to:  
[www.keysight.com/find/tap](http://www.keysight.com/find/tap)

Download the latest KS8400B *PathWave Test Automation* software at:  
<https://www.keysight.com/us/en/product/KS8400B/pathwave-test-automation.html>

Download the latest SL1200A Grid Integration and Compliance Test Automation Suite package from:  
<https://www.keysight.com/us/en/lib/software-detail/computer-software/sl1220a-ac---grid-test-sequencing-plugin.html>

**NOTE**

**IMPORTANT licensing information:** The SL1200A Grid Integration and Compliance Test Automation Suite package includes both the SL1220A and SL1221A Plugins. Plugin licenses are exclusive. Test Steps for plugins not licensed are visible but not usable.

You must license the SL1220A plugin to use the SL1220A AC/Grid Test Sequencing Plugin test steps and you can use them without using any of the SL1221A PHIL-based Anti-Islanding Compliance Test Automation Plugin test steps.

Similarly, you must license the SL1221A PHIL-based Anti-Islanding Compliance Test Automation Plugin to use the IEEE 1547.1-2020 Compliance Test Automation Software Test Steps and you can use them without using the SL1220A AC/Grid Test Sequencing Plugin test steps.

---

## Additional Keysight Test Automation Platform (TAP) Resources

- Help with licenses: call **1-800-829-4444** for Keysightcare or email at: [usa\\_orders@keysight.com](mailto:usa_orders@keysight.com)
- <http://www.youtube.com/@opentap158>
- <https://www.keysight.com/us/en/support/KS8400B/pathwave-test-automation.html>
- <https://www.keysight.com/us/en/assets/3122-1326/application-notes/PathWave-Test-Automation-Training-Editor-Introduction.pdf>

## Definition of Terms

**Bench Settings:** Configure an instrument's address and other settings.

**Log Panel:** The Session Log is a text (.txt) file generated each time you start the Editor. It contains messages generated when the program runs.

**Macro Step:** One Test Step involves multiple Test Steps.

**Package:** Packages contain one or more Plugins and other related files (such as data files or README files), custom test steps, instruments, DUTs, result listeners and test plans. Packages are installed/removed with the Package Manager.

**Package Manager:** The Package Manager allows you easy access to packages. It can be configured to point to any server where packages are hosted. The Package Manager lets you download and install preexisting packages.

**Plugin:** Plugins provide additional TAP functionality. They are distributed in Packages that contain DLLs and other required files.

**Resources:** Resources are called before the Test Plan execution starts and are closed when the Test Plan execution ends.

**Resource Bar:** The Resource Bar at the bottom of the Editor shows the currently configured DUTs, Instruments, and Results Listeners. For example, the following graphic shows one DUT (*TimeDut*), two Instruments (*PSU*, *TEMP*), and three Results Listeners (*Log*, *SQLite*, *CSV*).

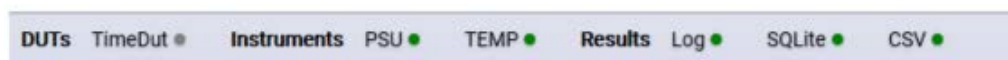

In the Resource Bar, you can: add additional resources, select a listed resource to open its settings to modify or remove it, etc.

**Results Viewer:** View results from executing the Test Plan. Lets you plot results, track trends, and find errors. Results may be stored as either a text log file, a CSV file, or an SQLite Database file.

**Run Explorer:** This window displays basic information about the history of the test plan runs stored in the SQLite database, including a Run ID, Test Plan Name and Verdict (Pass, Fail, or Error).

**Test Plan:** A Test Plan contains a sequence Test Steps and associated data. They are stored as XML files with the *.TapPlan* file extension.

**Test Step:** Individual steps in the Test Plan. Some Test Steps can have children. A Child Test Step is an ordinary step that is inserted as a child of another step. Child Test Steps are indented from the list of regular test steps.

**Test Step Settings:** Test Step Settings panel lets you edit the settings for the step selected in the test plan. Settings are properties that are automatically reflected in the TAP Editor. They are loaded and saved when the Test Plan is loaded/saved.

**Timing Analyzer:** Timing Analyzer results are based on log files.



# 1 Install KS8400B Test Automation

This section describes installation and how to begin using the KS8400B Pathwave Test Automation software.

In this chapter:

- Installation [page 12](#)
- Start the Test Automation Editor [page 13](#)
- Introduction to the Test Automation Editor [page 14](#)
  - Editor Panels [page 15](#)
  - Menu and Resource Bars [page 15](#)
  - Dockable Panels [page 15](#)
  - Create a Simple Test Plan [page 16](#)
- Congratulations! You have just run your first test plan! [page 18](#)

## Installation

- 1 Uninstall any previous versions of KS8400B Pathwave Test Automation. On the machine you want to run Keysight Test Automation:
  - Select **Windows Start > Control Panel**.
  - Select **Programs and Features**.
  - Find **Keysight Test Automation**.
  - Click **Uninstall**.
- 2 Download the latest KS8400B Pathwave Test Automation software at: <https://www.keysight.com/us/en/product/KS8400B/pathwave-test-automation.html>
- 3 Scroll down. Under **Software**, click: • *Drivers, Firmware & Software*.
- 4 Click: *PathWave Test Automation Software Download*.
- 5 Click **Download** to download the current version.
- 6 Select: *Full Installer (PathWave Test Automation 9.23.x)*.
- 7 Fill out the form then click **Download**.
- 8 After the software downloads:
  - Launch (*Run as Administrator*) **TestAutomation.Developer.version.exe**.
  - Follow the prompts to completely install PathWave Test Automation.
- 9 Select and purchase a Keysight KS8400B license.
  - You will receive an *Entitlement Certificate* when you purchase a license.
  - Follow instructions in the *Entitlement Certificate* to redeem the license.
  - Save the license file (.lic) to a temporary location on the C: drive of the computer where you have installed the KS8400B software.
  - If you did not receive or cannot find your entitlement certificate, contact: <https://www.keysight.com/us/en/contact.html>
- 10 Install the license:
  - Start Keysight PathWave License Manager.
  - Click the **+Add a License File** button.
  - Browse to your **.lic** file and click **Open** to install your trial license.

Congratulations! You are now ready to use KS8400B Pathwave Test Automation.

## Start the Test Automation Editor

- 1 Select **Start > Keysight Test Automation** to start the **Editor**.
- 2 The **Editor** displays a welcome screen with an introduction of what is included in the Test Automation and useful links to help you get started.
  - Uncheck the *Show welcome screen at startup* checkbox to hide the welcome screen on startup.
  - Close the *Welcome screen*.

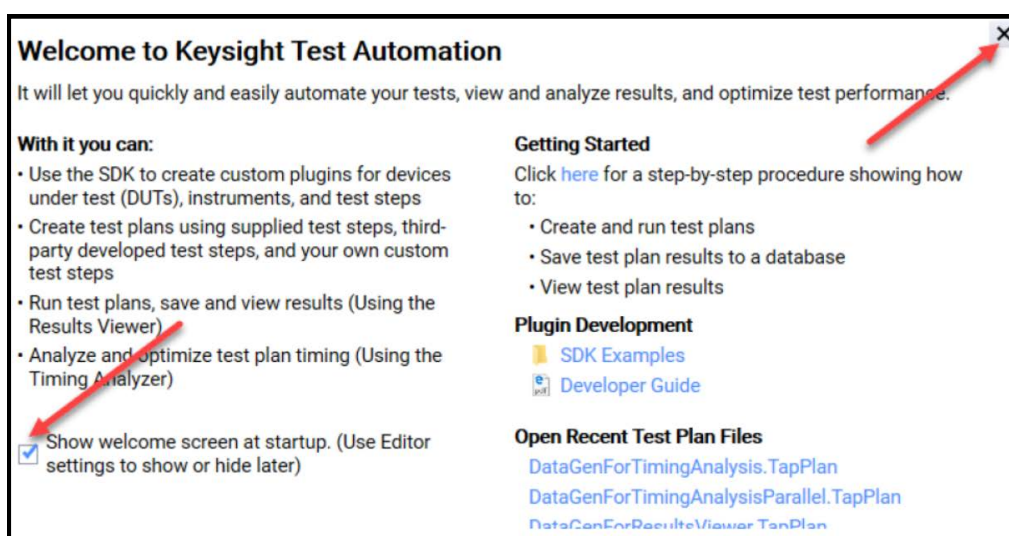

## Introduction to the Test Automation Editor

The main Editor contains six components or panels:

- **Menu Bar**
- **Test Plan Control Bar**
- **Test Plan Panel**
- **Test Step Settings Panel**
- **Log Panel**
- **Resource Bar**

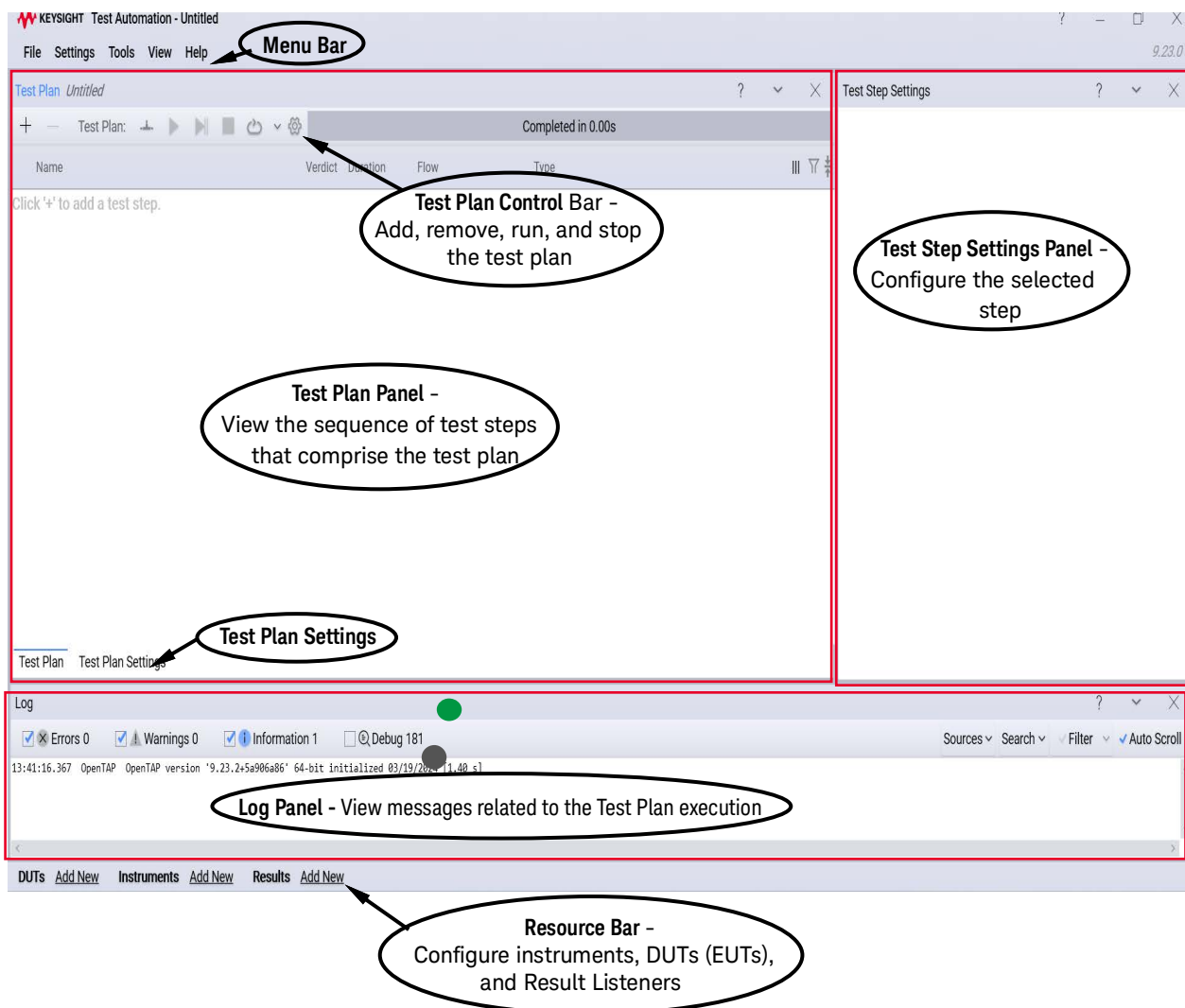

There is also a **Macro Test Steps** panel that is not shown above. It is used only with Macros and is not used in this tutorial.

## Editor Panels

The *Test Plan Panel* displays the test steps that have been added to the current test plan. If you click on a test step, you can see the related configuration in the *Test Step Settings Panel*. A test step's configuration settings can include, but are not limited to, input and output settings, and resources such as DUTs and instruments. *Test Plan Settings Panel* lets you edit the settings of the entire test plan.

The *Log panel* displays log messages from PathWave Test Automation during startup and during test plan execution. Log messages are classified as **Error**, **Warning**, **Information**, and **Debug** level events. The content displayed in the log panel is also saved in the Session log, which can be found at *\*/%TAP\_PATH%/SessionLogs\**.

## Menu and Resource Bars

The *Menu Bar* provides the following:

- **File** - lets you open and save test plans among other options.
- **Settings** - let you configure the Editor, the Engine, and the Results settings and gives you the option to configure resources (connections, instruments, and DUTs) via *Bench Settings*.
- **Tools** - let you open the Package Manager, Results Viewer, Run Explorer, and Timing Analyzer.
- **View** - allows for panels to be shown/hidden or for custom panels to be displayed and docked.
- **Help** - provides links to OpenTAP documentation.

The *Resource Bar* shows what is currently configured for PathWave Test Automation. *Resource* is the general term for a Device Under Test (DUT), instrument, or result listener used by a test plan. Status indicators next to the resource indicate its state:

- Green light = in use
- Grey light = not currently in use

## Dockable Panels

The *Test Plan*, *Test Plan Settings*, *Test Step Settings*, *Log*, and *Step* panels are dockable. This allows you to:

- **Float** the panels. They can be resized. They also minimize and close with the main window.
- **Preset** the desired layout. Select *View > Presets* to return hidden, floating, or docked panels to their default locations.

## Create a Simple Test Plan

Let's take a closer look at creating a test plan formed by some test steps.

- 1 Click the **+** icon in the Test Plan panel or press **Ctrl+T**:

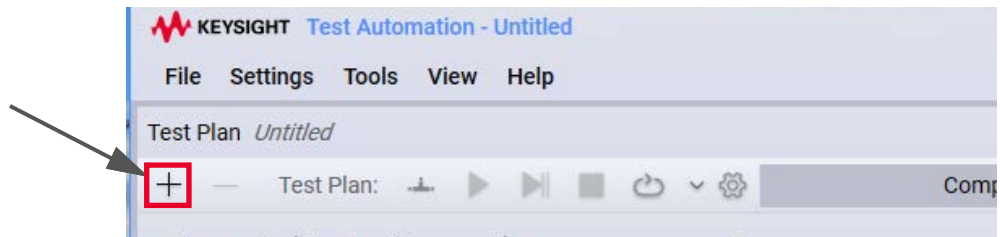

- 2 The *Test Steps* window opens, displaying a list of available test steps organized in expandable groups:

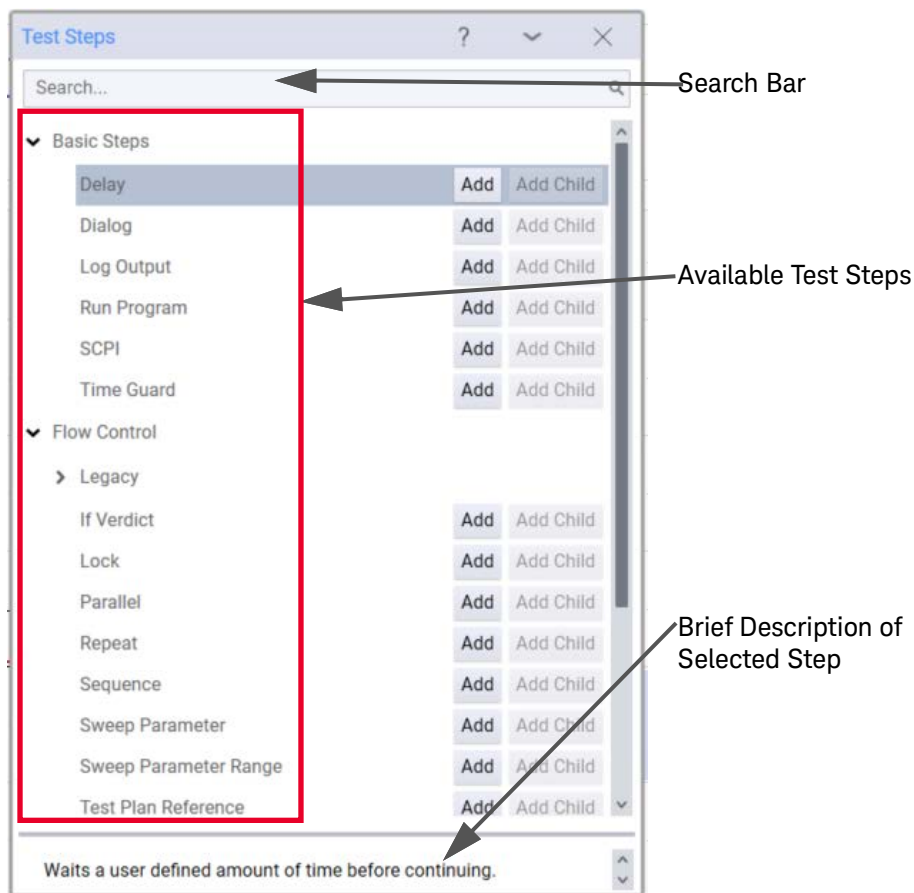

PathWave Test Automation comes preinstalled with the *Basic Steps* and *Flow Control* Plugins. Custom test steps are also displayed here. As your list of test steps grows, the search bar at the top becomes increasingly useful.

**3** In the *Test Steps* dialog box, select *Flow Control* and scroll down. Add a *Repeat* step. Either:

- Select **Repeat** and click **Add**, or
- Double-click the **Repeat** step.

The description of the step appears at the bottom of the window.

**4** Select *Basic Steps* and scroll down if necessary. Add a *Delay* child step:

- Select **Delay**
- Click **Add Child**

**5** Add a **Log Output** step, using either the **Add** button, or by double-clicking. A *Step* is added based on the scope of the previous step. In this case *Delay* was a child step of **Repeat**, so *Log Output* will be a child step of **Repeat** as well.

Your test plan should now look similar to this:

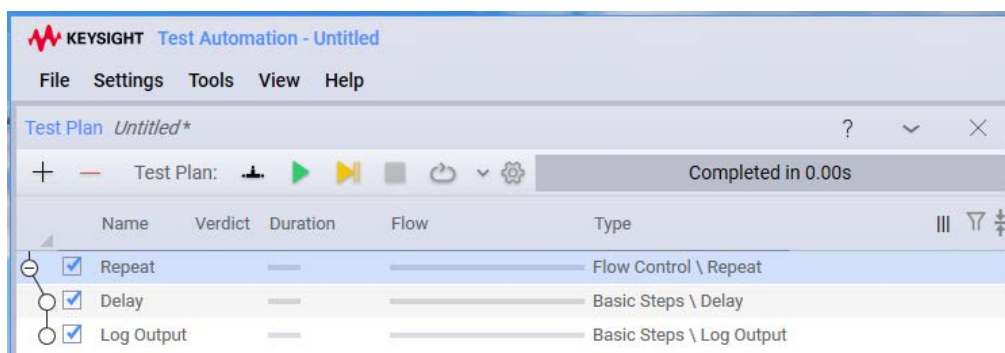

- Child steps are indented in the Editor.
- Reorder *Test Steps* by manually dragging them to a new location.

**6** Close the **Test Steps** window.

**7** Select the **Repeat** step by clicking on it. The *Test Step Settings panel* now shows these settings:

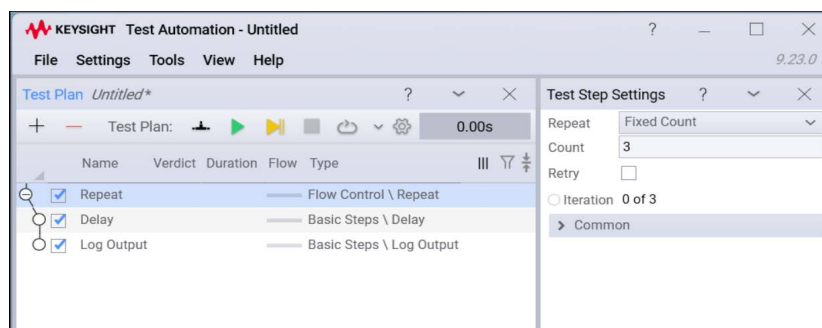



This means that the **Delay** and **Log Output** steps will execute three times.

#### NOTE

If the *Step Settings* panel does not appear, click *View > Panels > Test Step Settings*.

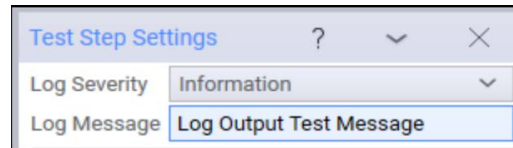
- 8 Select the **Delay** and **Log Output** steps respectively and inspect their *Step Settings*. Click on **Log Output** and enter your own **Log Message** in the text box:



- 9 Run the test plan by clicking  or by pressing **F5**.
- 10 After the run completes, scroll through the Log Panel to find your log message:

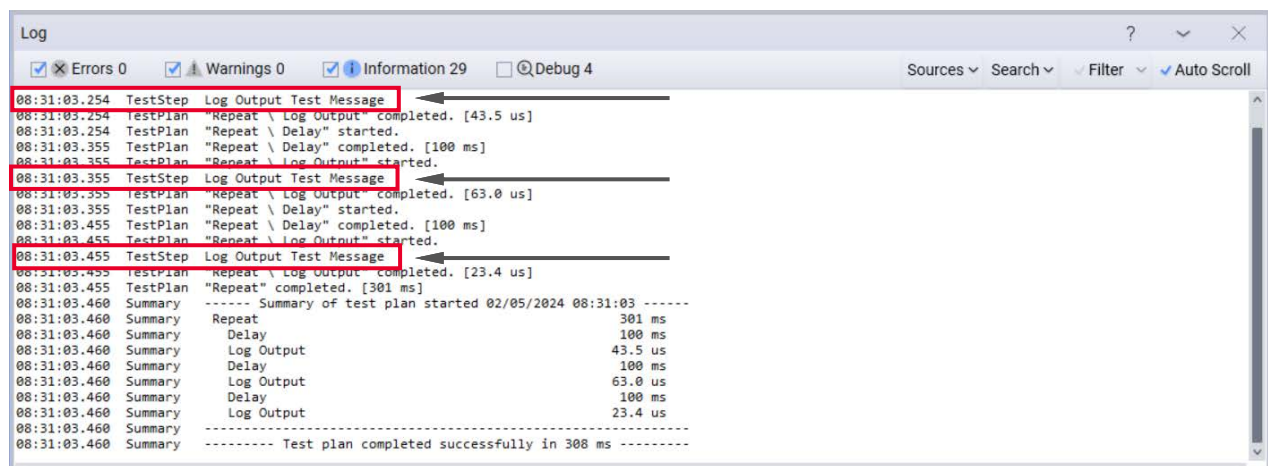

- 11 If you don't see your log message:

- Make sure that the *Information* tab in the Log panel is checked. This is needed because the Log Output step's *Log Severity* setting is set to *Information*.
- The *Search* button on the right of the *Log Panel* can also be used:

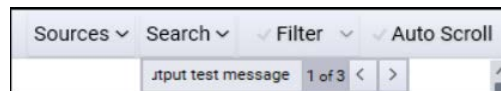

Congratulations! You have just run your first test plan!

## 2 Demonstration Example

In this chapter:

- Install the Demonstration Package [page 20](#)
- Construct the Test Plan [page 21](#)
- Use the Results Viewer and Run Explorer [page 25](#)
- Timing Analyzer [page 31](#)
- Saving Test Plans [page 33](#)
- Optional: Add a Title to Your Test Plan [page 33](#)
- This Completes the Exercises on the Editor [page 33](#)

## Install the Demonstration Package

This chapter shows how to install a package containing demonstration test steps and instruments. We will use the Demonstration Plugin for simulating charging and discharging batteries that involves a power analyzer. You do not need access to instruments or other plugins for this example.

- 1 Click **Tools > Package Manager**.
- 2 The *Package Manager* opens. It can be configured to point to any server where packages are hosted. The *Package Manager* allows you easy access to packages. Packages typically contain one or more Plugins and other related files (such as data files or README files):

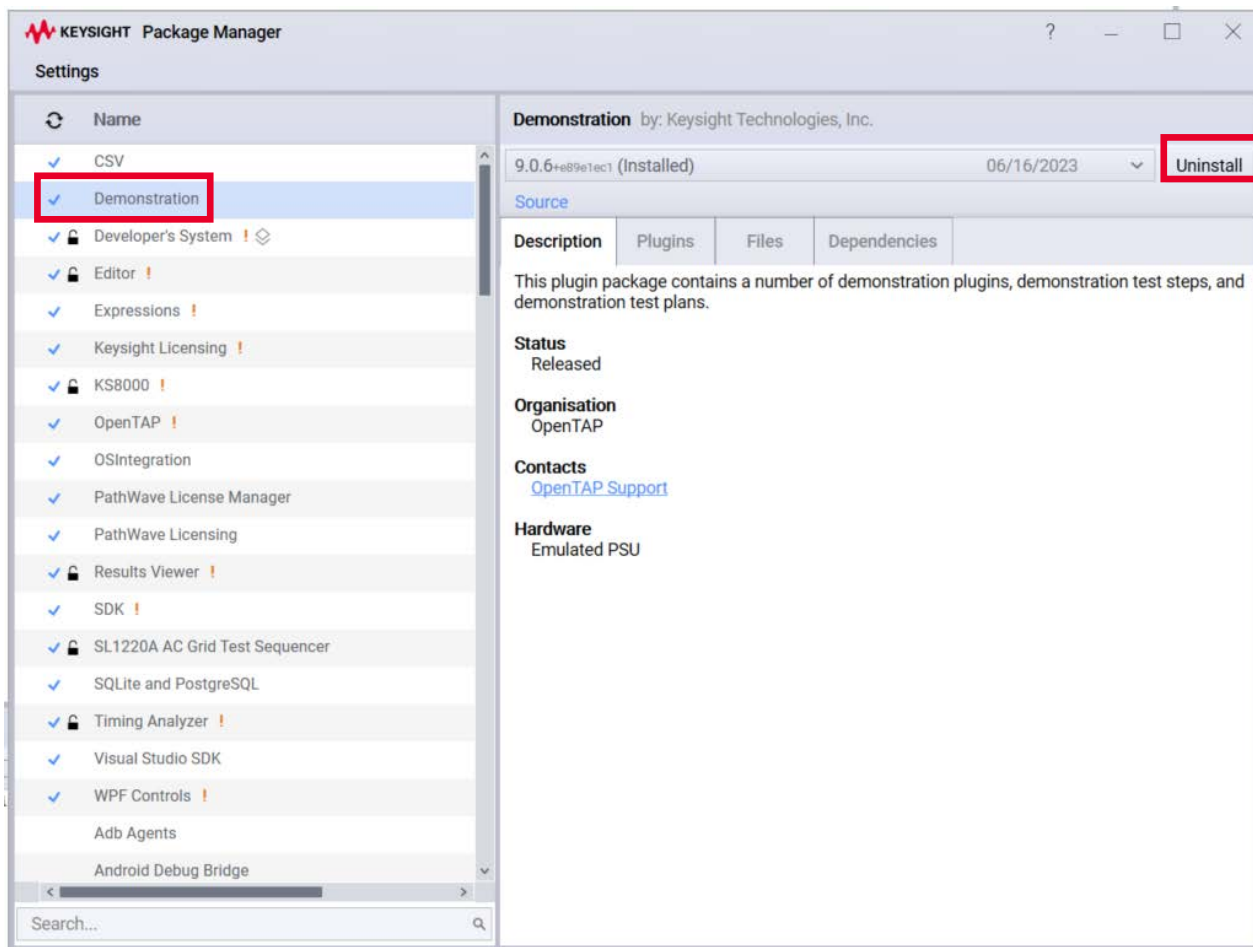

In the *Package Manager*:



- Selecting a *package* in the left panel displays information about that package. Packages can contain custom test steps, instruments, DUTs, result listeners and test plans.
  - The *Description* tab gives a general overview of the package.
  - The *Plugins* tab shows all the custom test steps, instruments, DUTs, result listeners and other components contained in the package.
  - The *Files* tab shows all the files included in the package.
  - The *Dependencies* tab shows if the package is dependent on any other packages.
- 3** Scroll down and select the *Demonstration* Plugin (which is included with the PathWave Test Automation installation) and click **Install**. After installation the *Demonstration* Plugin displays a check mark in front, indicating that it is installed.
  - 4** Close the *Package Manager* window.

**NOTE**

If you have trouble installing a Package, close the Test Automation Editor and re-install the package. You can run the *Package Manager* from the Windows list of applications.

---

## Construct the Test Plan

- 1** Remove any test steps left over from the previous example. Select the *Test Step*, then either:
  - Click the  button, or
  - Press **Delete** on the keyboard.
- 2** Clear the **Log** panel. Right click on the Log panel then select *Clear Log Panel*.
- 3** Click the  button (or press **Ctrl+T**) to open the *Test Steps* window. Notice that there is now a new group called *Demo*.
- 4** From the *Demo* group's *Battery Test* subgroup, add a:
  - *Charge* stepand a
  - *Discharge* step



- 7 We need to add a Power Analyzer instrument as a resource.
  - In the *Resource Bar* at the bottom of the panel, select **Add New** next to *Instruments*.

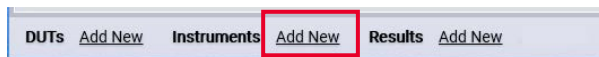

- In the *Bench Settings* window (which also can be opened via **Settings > Bench > Instruments**), select the **+** in the lower-left corner.

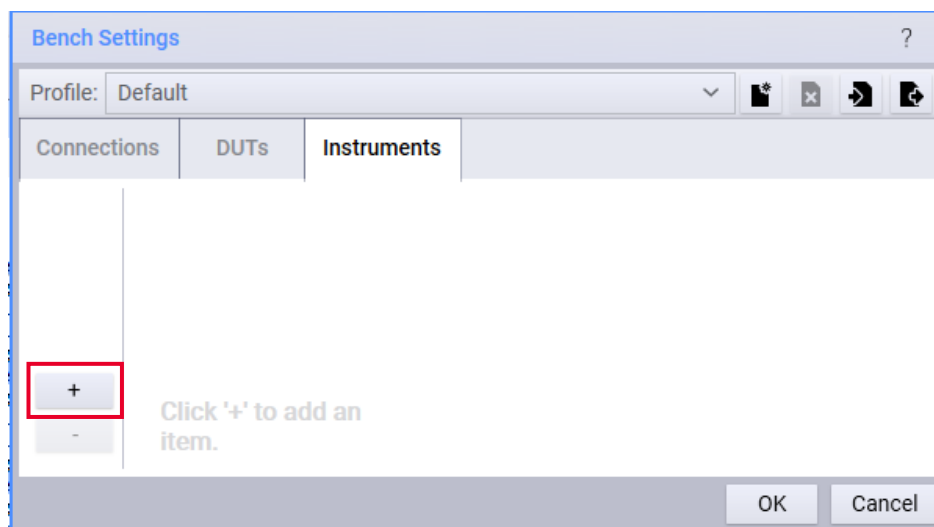

- The *Add New Instrument* window opens. Select **Power Analyzer**, then **Add**.

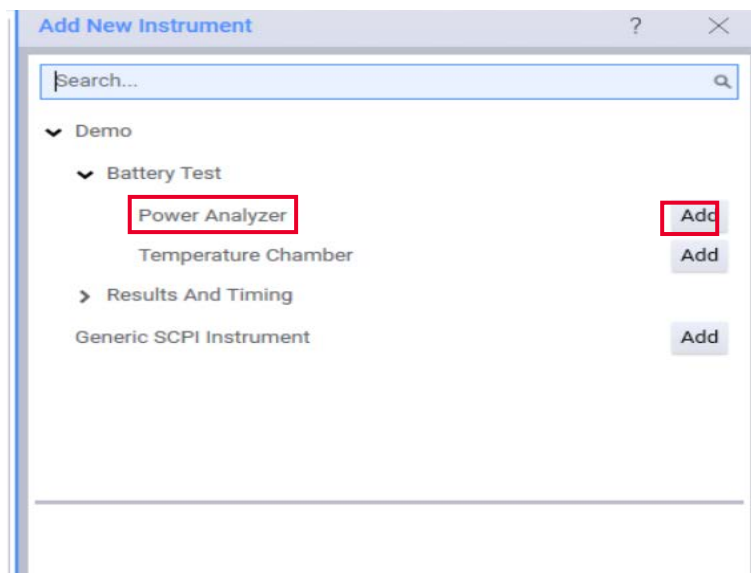

- Close the *Add New Instrument* window.

- 8 Next you would typically configure the instrument's address and other settings. Because this is a simulated instrument, click **OK** to close the *Bench Settings* window.
- 9 In the Test Plan panel, the *Resource Bar* now shows one Instrument: **PSU**.



- 10 In the *Step Settings* for both the *Charge* and *Discharge* steps select the **PSU** as the Power Analyzer resource from the drop down menu. Make certain that you do this for both *Charge* and *Discharge* steps.

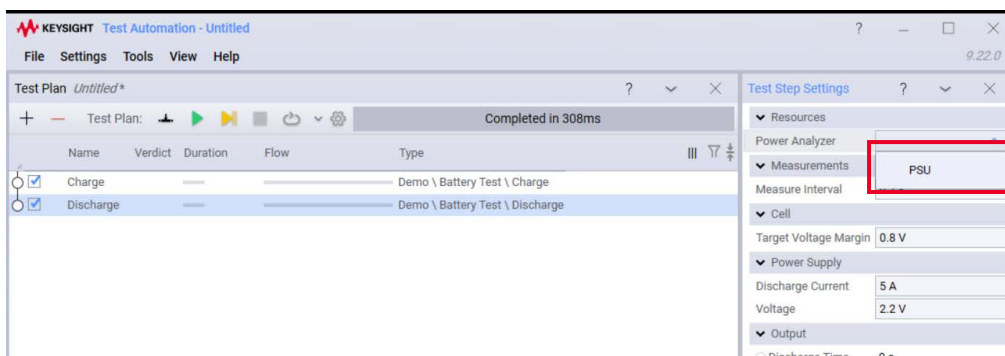

## Use the Results Viewer and Run Explorer

In PathWave Test Automation, a result listener is also a Resource, just like an instrument or DUT. Result listeners store data created by the test steps.

You can add database-style result listeners that allow for a more in-depth view of the data. This lets you plot results, track trends, and find errors. This can all be done in the *Results Viewer*.

To use the *Results Viewer* and the *Run Explorer*, a database *Result Listener* is needed. Let's add an **SQLite** result listener. **SQLite** is a lightweight database that consists of a single file that encapsulates the full data set. You can use other types of databases too.

Let's add the Log result listener as well. Multiple result listeners can be configured at the same time and will process the data from PathWave Test Automation in parallel. This happens in a separate thread, so it doesn't impact the execution speed of the test plan.

- 1 Select **Results > Add New** from the *Menu Bar*. This opens the *Settings* dialog box:
  - Click the **+** in the bottom left corner of the dialog box. This opens the *Add New Results Listener* dialog box.
  - Under the *Text* group, select *Text Log*, then **Add**.
- 2 In the *Add New Result Listener* window
  - Expand the **Database** group.
  - Add the *SQLite* Result Listener, then **Add**.

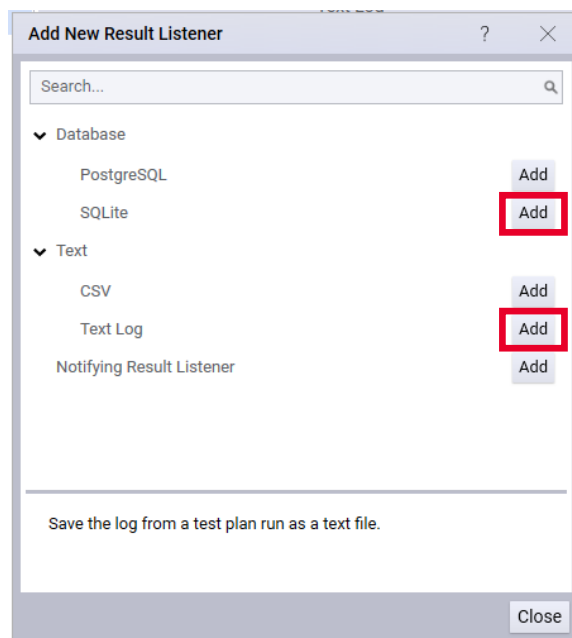

- 3 Close the *Add New Result Listener* window, then close the *Add New Results Listener* window.

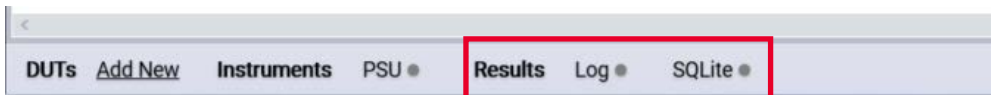

- 4 Execute the test plan by clicking  in the Test Plan panel or by pressing **F5**.
- 5 Let's make the results a little more interesting. Select the **Charge Test Step** and change the *Charge Current* from 10 A to 15 A.

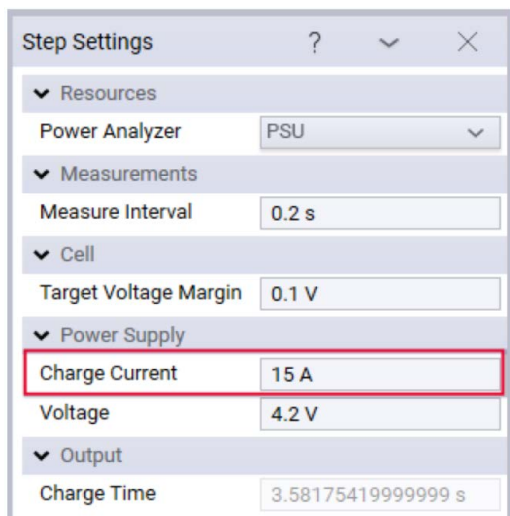

This creates a separate run result when you run the test plan again.

- 6 Run the test plan again so you can look at the data that was captured.
- 7 Select **Tools > Run Explorer**. The *Results Viewer* and *Timing Analyzer* also can be opened directly from the *Tools* menu.

The *Test Plan Run Explorer* opens. This window displays some basic information about the history of your test plan runs stored in the SQLite database, including a *Run ID*, *Test Plan Name* and *Verdict* (Pass, Fail, or Error). In our case, neither of the last two have been set:



- 8** Now we will view the results of those test runs:
- Hold **Shift** and select both **Test Plan Runs** at the top of the *Test Plan Run Explorer* list (your *Run IDs* may be different).
  - Open the *Results Viewer* by either:
    - Clicking the **View results from test plan** button –  , or
    - Right clicking the test plan runs and selecting **Plot Selected**.
  - The *Results Viewer* shows two different plots one under the other (one for *Charge* and one for *Discharge*), as well as some *Chart Settings* to the right:

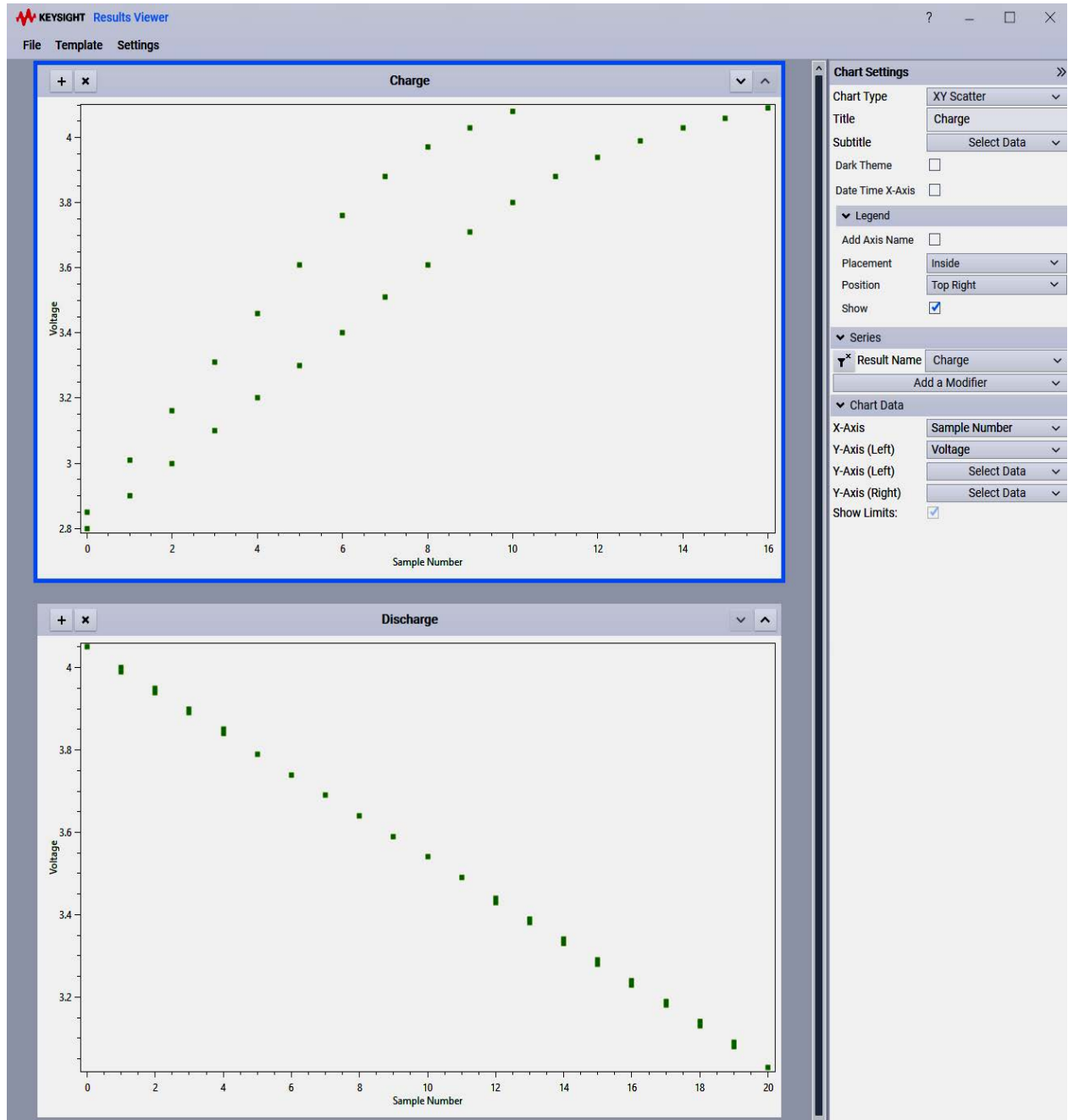

- Select the *Charge* plot, a blue box appears around the chart.
- Locate the *Series* setting in the Charge Settings menu. Select **Add a Modifier** and click **Split**:

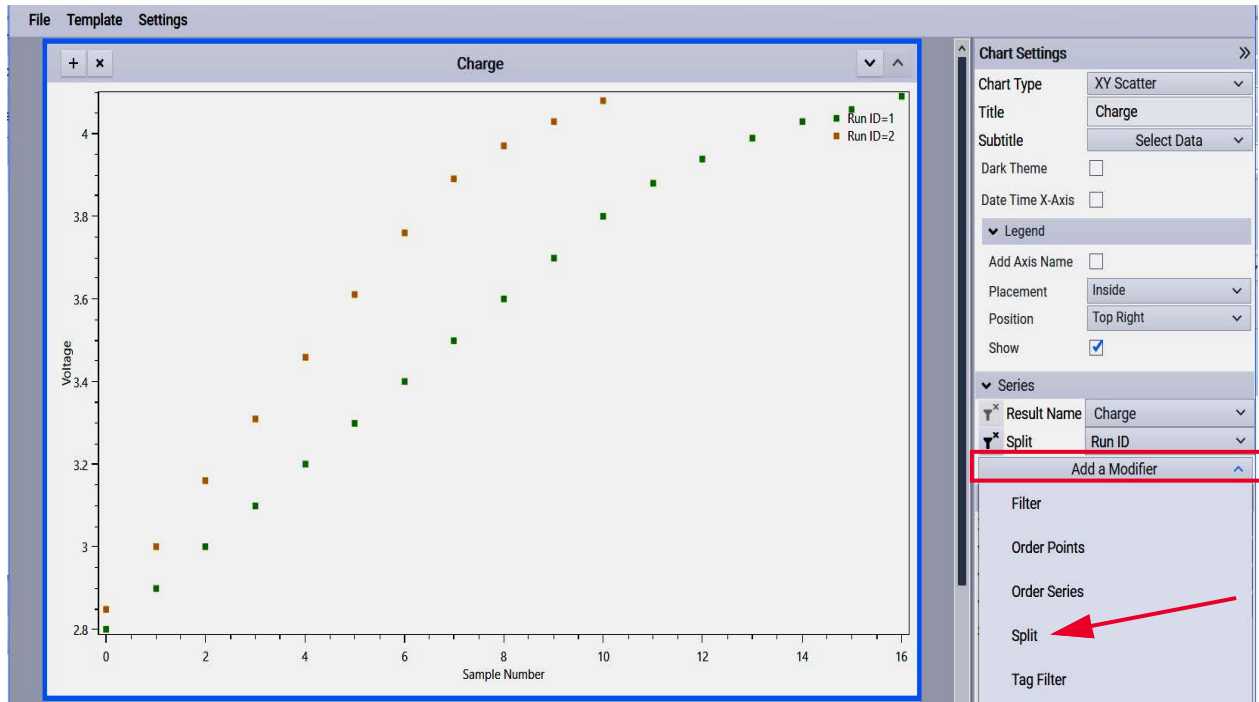

- Click on the **Split > Run ID** drop-down arrow, navigate to **Step > Power Supply**, and select **Charge Current2**:

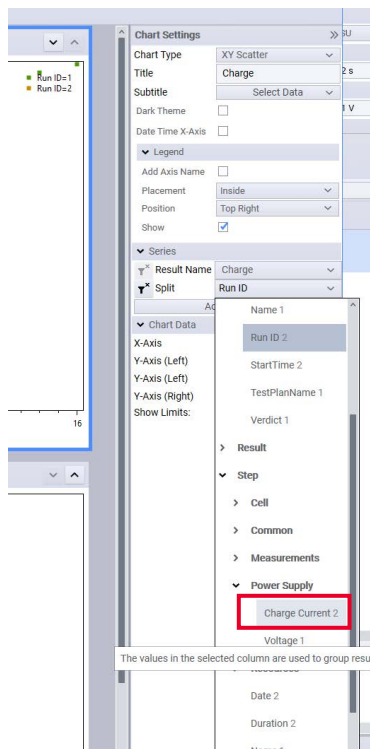

*Charge Current* is here because it is a *setting* in the Power Supply group of the Charge test step. The number “2” next to Charge Current indicates that there are two unique values in the data set.

- The chart automatically updates:

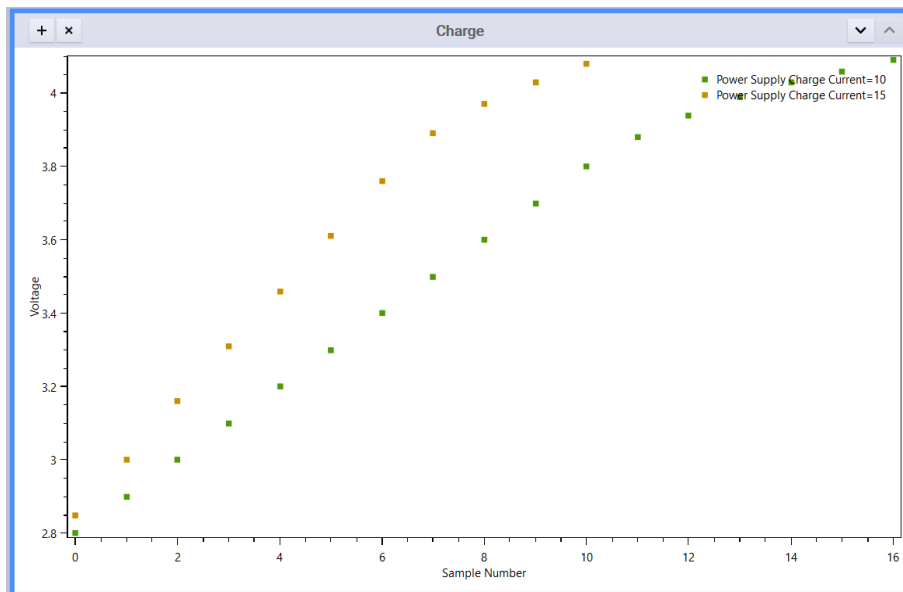

**11** Play around with the other *Chart Settings*. PathWave Test Automation provides powerful plotting capabilities that make evaluating data fast and easy. Some of the most commonly used are:

- Chart Types, such as XY Scatter, XY Line, Histogram, etc.
- Series Modifiers, particularly **Split** and **Filter**.
- Chart Data, which is based on what is passed in to the Result Listener by the test step.

The *Chart Settings* only apply to the selected chart, which is highlighted in blue. This allows you to configure the charts individually.

**12** Close the *Results Viewer*.

## Timing Analyzer

The *Timing Analyzer* is another powerful tool built into PathWave Test Automation. It can optimize test plans, locate bottlenecks in execution, and identify areas for parallel execution.

- 1** Navigate back to the *Test Plan Run Explorer*.
- 2** Click the **Compare logs selection mode** icon, that adds check boxes in front of each run:



- 3** Select the top test plan as *Left* and the other as *Right*:

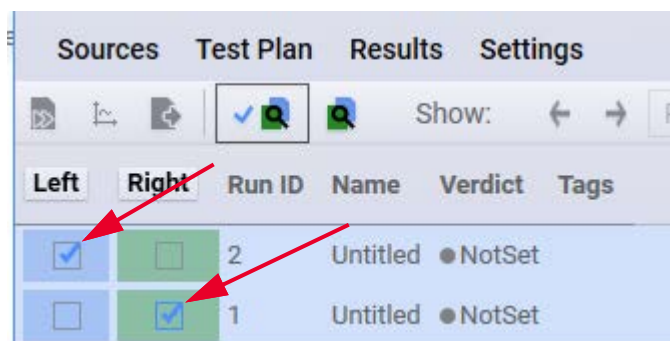

- 4** Click the **Compare logs for selected runs** icon (the magnifying glass icon on the right) to open the *Timing Analyzer*:



- The *Timing Analyzer* displays each element of the test plan on the left. The *Time View* window on the right shows time sequentially, with a visual break down of how long each action took and when the action occurred:

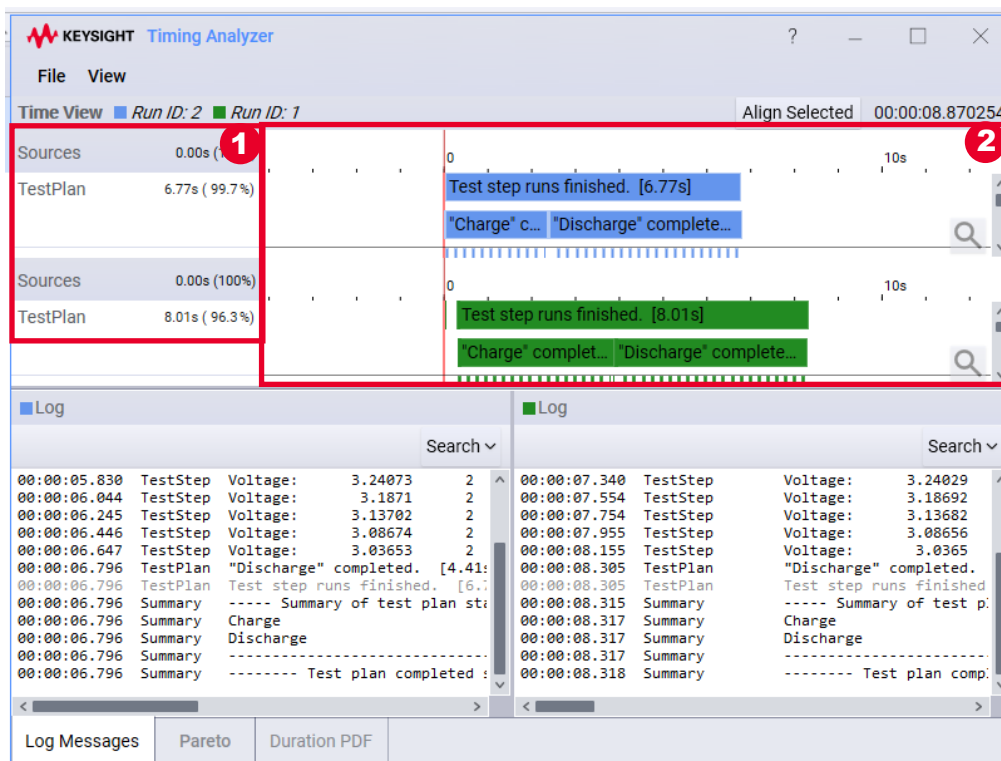

- The *Time View* window supports the standard zooming functionality with either a mouse wheel or by using **Ctrl+** or **Ctrl-**, as well as left and right scrolling.
- The Log messages are also linked to the *Time View* graphs. Select one of the messages and notice that the associated bar becomes highlighted with a thin red box around it.
- Zoom in on the *Charge completed time bar*:

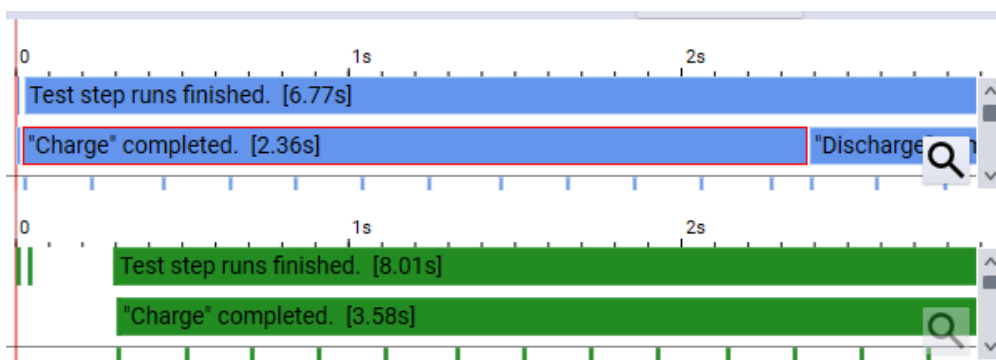

- 9** The times for the *Charge* steps (your times may be slightly different):
- The top test run took 2.36 seconds
  - The bottom test run took 3.58 seconds

This is because we changed the *Charge Current* between runs. A 5 A increase in charge current resulted in a 1.17 second decrease in charge time. This is an example of the type of timing analysis that can be done easily with the *Timing Analyzer*.

## Saving Test Plans

Select *File > Save*, enter a file name for the test plan, and click **OK**.

Test Plans are saved with a *TapPlan* file extension. The default location is at the root folder of the installation folder, typically either”

- *C:\Program Files\Keysight\Test Automation* (for 64-bit)
- *C:\Program Files (x86)\Keysight\Test Automation* (for 32-bit)

### NOTE

If the Editor closes improperly, it will try to restore the Test Plan that was last open.

## Optional: Add a Title to Your Test Plan

To assign a name to your test plan you must save it. Click: **File > Save As....** This opens a Windows Explorer dialog box where you can navigate to a folder and specify a file name for your test. This file name becomes the title for your Test Plan.

## This Completes the Exercises on the Editor

We hope you found it interesting and are keen on learning more in the following labs and using PathWave Test Automation on your own!



# 3 SL1220A /SL1221A Plugin Installation

This chapter describes installation SL1200A Grid Integration and Compliance Test Automation Suite (the Package). This package contains both the SL1220A AC/Grid Test Sequencing Plugin and the SL1221A PHIL-based Anti-Islanding Compliance Test Automation Plugin.

In this chapter:

SL1200A Package Installation [page 36](#)

SL1200A Package Installation Requirements [page 36](#)

Install SL1200A Grid Integration and Compliance Test Automation Suite [page 39](#)

## SL1200A Package Installation

### NOTE

**IMPORTANT licensing information:** The SL1200A Grid Integration and Compliance Test Automation Suite package includes both the SL1220A and SL1221A Plugins. Plugin licenses are exclusive. Test Steps for plugins not licensed are visible but not usable.

You must license the SL1220A plugin to use the SL1220A AC/Grid Test Sequencing Plugin test steps and you can use them without using any of the SL1221A PHIL-based Anti-Islanding Compliance Test Automation Plugin test steps.

Similarly, you must license the SL1221A PHIL-based Anti-Islanding Compliance Test Automation Plugin to use the IEEE 1547.1-2020 Compliance Test Automation Software Test Steps and you can use them without using the SL1220A AC/Grid Test Sequencing Plugin test steps.

## SL1200A Package Installation Requirements

### NOTE

**IMPORTANT:** Install the Python Run Time Environment version 3.12 (recommended) before installing the SL1200A Grid Integration and Compliance Test Automation Suite package (version 3.0 or later). You should also install the latest version of Keysight IO Libraries Suite, which is shown in the next section.

### Install the Python Run-Time Environment

No license is required for the Python Run-Time Environment.

- 1 Install Python Run-Time Environment from: [www.python.org](http://www.python.org).
- 2 Select: **Downloads > All releases**. Keysight recommends installing version 3.12.

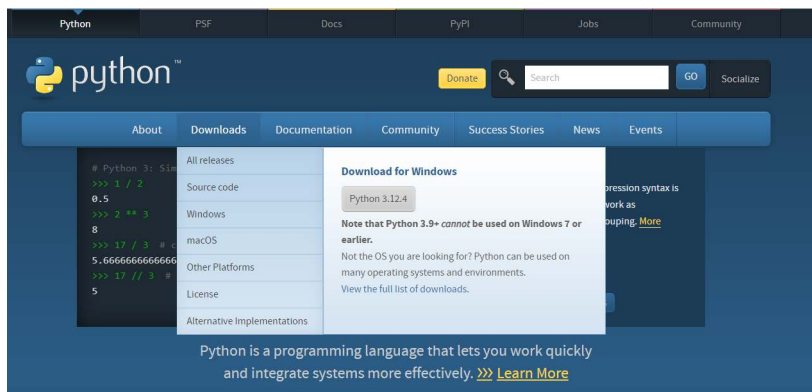

- Be sure to install the 64-bit python
  - Be sure to install for "all users"
  - Be sure to install pip
- 3** Check the box for **Add Python.exe to PATH**. You may need to check the box for **Use admin privileges....**



- 4** Click **Customize Installation**. This opens the following dialog:

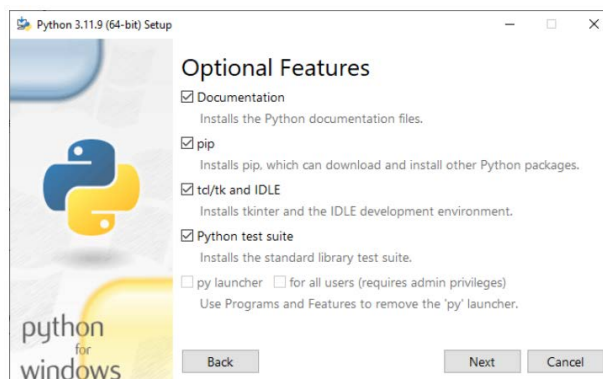

Make certain that **PIP** is selected.

- 5** Click **Next** to install.  
PIP packages should install automatically. However, if that process fails, you can use the following locations and method of updating the packages that are required

**Note:** PIP Packages can also be installed manually as follows:

- *C:\Program Files\Keysight\Test Automation\Packages\SL1220A AC Grid Test Sequencer\opensvp\requirements.txt*
- *C:\Program Files\Keysight\Test Automation\Packages\SL1220A AC Grid Test Sequencer\PostProcessing\requirements.txt*
- *pip install -r requirements.txt*
- ...use the specific directories above or navigate to those locations and execute the command as shown.

## Install Keysight's IO Libraries Suite

Keysight IO Libraries Suite is required.

- 1 Install the latest version of Keysight IO Libraries Suite from: [IO Libraries Suite](#).
- 2 Scroll down to the **How to Download** section.
- 3 Click the **Download IOLS 2024** button. 
- 4 Locate the **IOLibSuite xxxxxx.exe** file in your **Downloads** folder.
- 5 Run the downloaded installer with **Admin Privilege**.
- 6 Follow all on-screen instructions.
- 7 Use **Keysight Connection Expert** to locate and identify test instruments in your test system.

Use **Keysight Connection Expert** to determine the IP Address or VISA address of instruments connected for IEEE 1547.1 Conformance Tests. Also, refer to the instrument's documentation. This would typically involve connection the DC Sources. The SL1200A Grid Emulator has its own discovery mechanism associated with the SL1200A Soft Front Panel.

## Install SL1200A Grid Integration and Compliance Test Automation Suite

The following procedure provides instructions to install Version 3.0 (or later) of the SL1200A Grid Integration and Compliance Test Automation Suite. Follow these instructions whether you are installing the plugin for the first time or are upgrading from an earlier version.

### NOTE

You won't be able to install a plug-in without the base license installed and active. That is: install *KS8400B* > Install *KS8400B License* > Install *SL1221A* > Install *SL1221A License*.

- 1 If it is open, close the KS8400B Test Automation *Editor*.
- 2 If you had a previous version of the SL1220A package (prior to 3.0), it must be uninstalled before proceeding. If you did not have a previous version installed, skip to **Step** below.
  - Navigate to *C:\Program Files\Keysight\Test Automation\*.
  - Click *PackageManager.exe* to open the KS8400 **Package Manager** directly.
  - Select (highlight) the old SL1220A package.

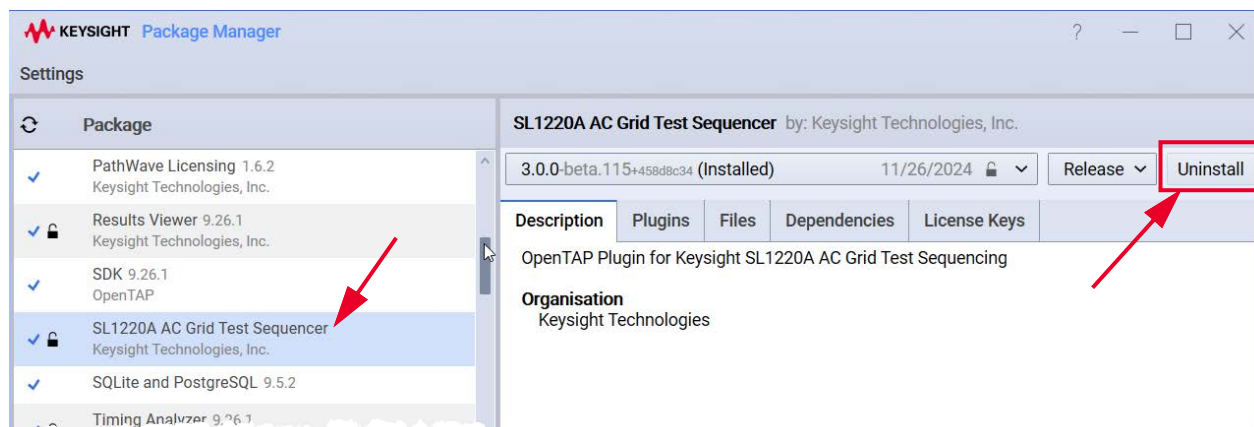

- Click the **Uninstall** to uninstall the old SL1220A package.

Download the latest SL1200A Grid Integration and Compliance Test Automation Suite package from:

<https://www.keysight.com/us/en/lib/software-detail/computer-software/sl1220a-ac---grid-test-sequencing-plugin.html>

- Select the current release of SL1200A Grid Integration and Compliance Test Automation Suite package (version 3.0 or later).
- Click the **Download** button.

- 3 Install the new version (3.0 or later) of the SL1200A Package:
  - After it downloads, double-click:  
**SL1220A\_AC\_Grid\_Test\_Sequencer-version.TapPackage**. A new *Package Manager* window opens.
  - Follow the prompts to install the package.
- 4 After the SL1200 package installs successfully, close the *Package Manager* window.
- 5 Reopen the *Test Automation Editor*.
- 6 Select and purchase an SL1220A AC/Grid Test Sequencing Plugin and/or the SL1221A PHIL-based Anti-Islanding Compliance Test Automation Plugin license.
  - You will receive an Entitlement Certificate when you purchase a license.
  - Follow instructions in the Entitlement Certificate to redeem the license.
  - Save the license file (\*.lic) to the computer where you have installed the SL1200A package.
  - If you did not receive or cannot find your entitlement certificate, contact: <https://www.keysight.com/us/en/contact.html>
- 7 Install the plugin license(s):
  - Start Keysight PathWave License Manager.
  - Click the **+Add a License File** button.
  - Browse to your **.lic** file and click **Open** to install your trial license.

**NOTE**

**IMPORTANT:** if you created test plans using versions 2.x or earlier of the SL1220A plug-in and ex

perience Namespace errors, use the following conversion process and utility to migrate the test plan file(s) to version 3.0:

**Navigate to:** *C:\Program Files\Keysight\Test Automation\Packages\SL1200A Grid Integration and Compliance Test Automation Suite\Tools\testplan\_migration.py*

**Run the script with a single argument (which is the .TestPlan file you want to migrate to 3.x namespaces). For example:**

```
python testplan_migration.py C:\TEMP\Old_TestPlan.TestPlan.
```

**There may still be some residual errors related to the old plugin when loading the Test Plan, but those issues will be resolved when you re-save the plan from the new plugin.**

# 4 Using the SL1220A AC/Grid Test Sequencing Plugin

In this chapter, we will learn how to control the output voltage of the SL1200A SL1200A Regenerative AC Emulator and set up measurement logging with live plotting panels by creating a simple test plan. This example test plan can become a template or starting point for a larger Test Plan.

In this chapter:

- Equipment and Software Requirements [page 42](#)
- Hardware Requirements [page 42](#)
- Software Requirements [page 43](#)
- SL1220A Programming Overview [page 44](#)
- Add SL1200A System Instruments [page 45](#)
- Create the Example Test Plan [page 47](#)
- Additional SL1220A Example TAP Programs [page 53](#)

## NOTE

**IMPORTANT licensing information:** The SL1200A Grid Integration and Compliance Test Automation Suite package includes both the SL1220A and SL1221A Plugins. Plugin licenses are mutually exclusive. Test Steps for plugins not licensed are visible but not usable.

You must license the SL1220A plugin to use the SL1220A AC/Grid Test Sequencing Plugin test steps and you can use them without using any of the SL1221A SL1221A PHIL-based Anti-Islanding Compliance Test Automation Plugin test steps.

Similarly, you must license the SL1221A PHIL-based Anti-Islanding Compliance Test Automation Plugin to use the IEEE 1547.1-2020 Compliance Test Automation Software Test Steps and you can use them without using the SL1220A AC/Grid Test Sequencing Plugin test steps.

## Equipment and Software Requirements

### Hardware Requirements

- One SL1200A Regenerative AC/Grid Emulator such as the SL1212A
- KS8400B TAP Software and license
- SL1200A Integrated Grid Test Automation Suite package and license for the SL1220A AC/Grid Test Sequencing Plugin

Refer to the SL1200A Grid Integration and Compliance Test Automation Suite Help File for more detailed information.

**The example discussed in this section should first be run with an open output as shown in the hardware configuration figure on the next page.** This ensures that proper operation of the plug-in can be verified without risking damage to equipment from improper programming. Once the test plan has been run, it can be used as a template for subsequent operation with a DUT.

#### **WARNING**

**RISK OF PROPERTY DAMAGE AND/OR DEATH: The following example training lab will program the SL1200 to output high voltages capable of injuring or killing a person. Any load or DUT connected to the SL1200 may be damaged if it is not properly rated. The L1, L2, L3, N, G, DC+ and DC- terminals should all be fully disconnected during the example training lab. Please take all proper precautions before proceeding with this exercise**

---

## Soft Front Panel

Keysight's SL1200A Series Regenerative AC/Grid Emulator Soft Front Panel (SFP) provides a tool for discovering and configuring your SL1200A Systems on your local LAN. Use this tool to update the firmware and gate ware of all components within the SL1215A rack. For detailed information, refer to the SL1220A SFP and help file.

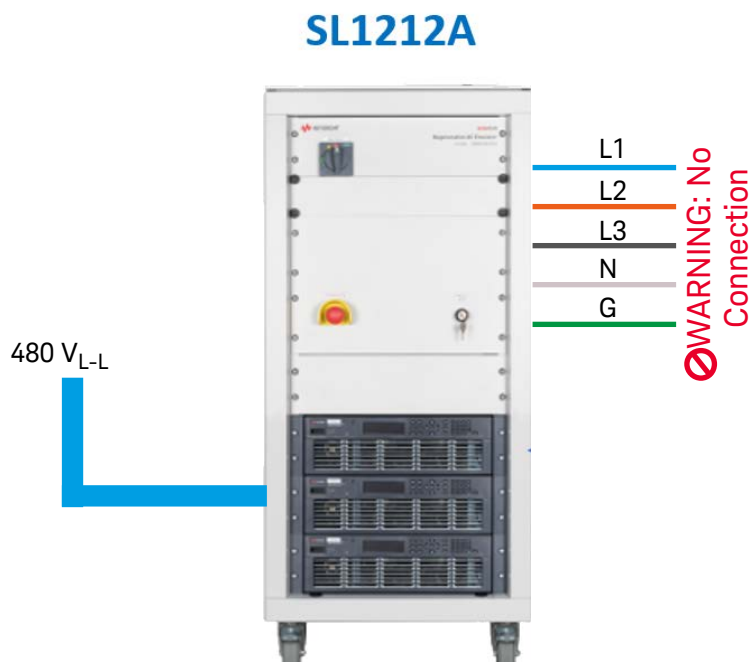

## Software Requirements

- Keysight KS8400B Pathwave Test Automation Platform (TAP) software and license
- SL1200A Integrated Grid Test Automation Suite package and license for the SL1220A AC/Grid Test Sequencing Plugin

See “[PathWave Test Automation Software](#)” on page 7 for detailed software installation information.

## SL1220A Programming Overview

Keysight's SL1220A AC Emulator section in the SL1220A Help File details all the TAP Steps available in the SL1220A Plugin. There are five major groups or sub-sections of TAP Steps:

- **Common** - provides general purpose Step that can be used in multiple Emulation Modes
- **Configure** - provides a single configuration Step for each Emulation Mode, which configures the SL1220A system
- **Measure** - provides a wide variety of measurements from the built-in Power Analyzer of the SL1220A system
- **Static** - provides Steps for changing set-points, slew rates, etc. which control the system over the LAN connection and execute at the performance level of the TAP and Windows environment
- **Transient** - provides Steps that run inside the controller of the SL1220A and has time-precision and 50  $\mu$ s time resolution for real-time operations

Programming always starts with *Configure* steps. These are described in the *Configuring the Emulation Model* section of the SL1220A Help File. *Configure* steps completely set up the SL1200A for a particular Emulation mode, where initial Set-points, Slew Rates, Control Limits, and Protection Limits are set. With a single Configure Step, the system is fully operational at that point. *Understanding Set Points, Slew Rates, Limits, and Trip Times* gives you an overview of the control parameters involved. *Protection* and *Control Limits* explains in greater detail the available *Limits* for monitoring and controlling the system, so you can avoid over-voltage or over-current, or you can cause the SL1200A system to open its output relay contactors to disconnect from the DUT if the Power Analyzer detects over-voltage or over-current.

*Measurements* and *Data Logging* explains the access to the built-in Power Analyzer of the SL1200A system. The *Data Logger* allows you to create .csv files with selected measurements for a particular test, and measurements are collected in background while other steps can be executed to stimulate the test environment. The Measure Steps provide a means of measuring results against limits, so your Test Plan can indicate success or failure.

The *External Triggering* section of the Help file explains how to synchronize the SL1200A with your test environment.

## Add SL1200A System Instruments

TAP software allows you to add an Instrument that gives you access to the Keysight SL1220A AC Emulator Plugin. Add an instrument by clicking the *Add New* button at the bottom of the Test Automation window:

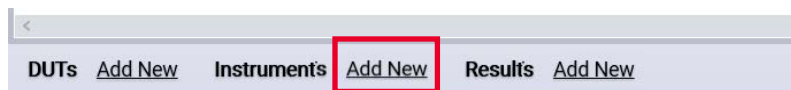

This opens the *Bench Settings* dialog box. Click the **+** button in the lower left to *Add New Instrument*.

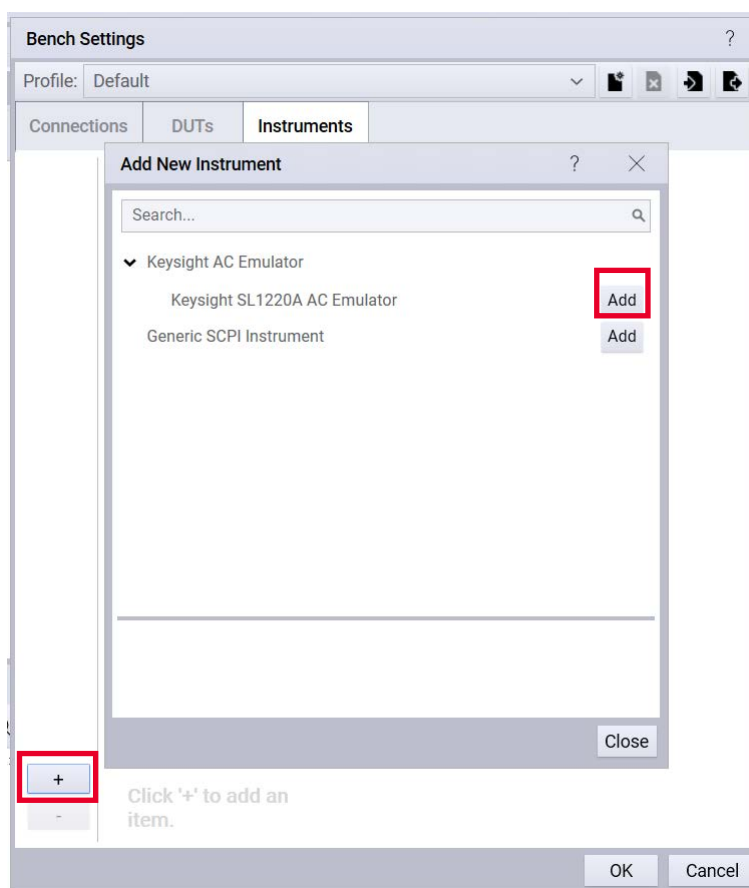

Expand the *Keysight AC Emulator* menu. Select the *Keysight SL1220A AC Emulator*. Click *Add*. Close the *Add New Instrument* box.

You will be presented with a dialog for setting the IP Address and choosing the model number of the system you want to program. The following screen capture shows entering the IP Address. If the system is connected to your computer via LAN, click the *Retrieve Device Number* button to determine which model number it is at that IP Address.



If desired, you can alter the default name of the instrument by double-clicking the name and changing it. Once you are done, click the **OK** button to return to the main *Test Automation* window.

## Create the Example Test Plan

This example can become a template or starting point for a Test Plan.

- 1 Got to *File > New* or press **CTRL+ N** on your keyboard to start a new test plan.
- 2 Clear the log panel. Right click on the log file panel then select *Clear Log Panel*.
- 3 Click the **+** button (or press **CTRL+ T**) to open the *Add New Steps* window. You will notice that there is now a new group called *Keysight SL1220A AC Emulator*.
- 4 Expand the *Keysight SL1220A AC Emulator* group's *Common* subgroup. Add a *Check ACE Errors* step<sup>1</sup>.

### NOTE

Insert this step at the beginning of your Test Plan. This allows it to send any messages into the Log Viewer and clear any previous error conditions that may have occurred.

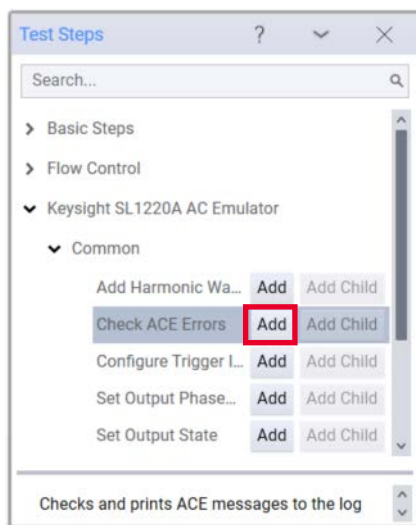

<sup>1</sup> ACE refers to AC Emulator

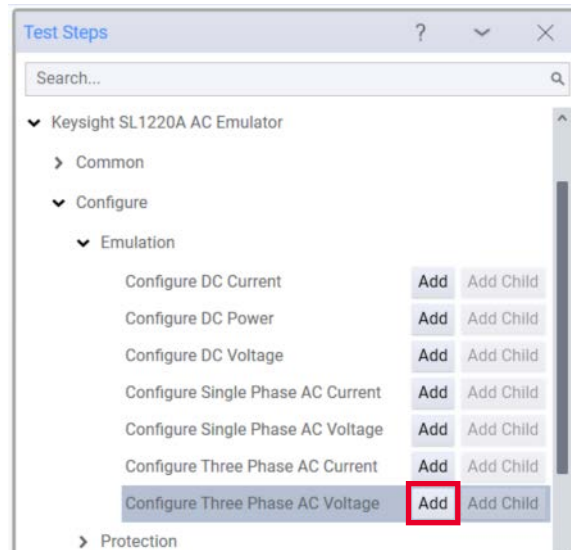

- 5 Expand the *Configure > Emulation* subsection. Add the *Configure Three Phase AC Voltage* step.



- 6 Close the Test Steps box.
- 7 In the Test Plan panel, click on the newly added *Configure Three Phase AC Voltage* step – the step should be highlighted in light blue. The **Test Step Settings** panel at the right of the screen has several fields to configure. If you cannot see the **Test Step Settings** panel, go to *View > Panels > Test Step Settings* at the top of your screen. If you still can't see the panel, go to *View > Presets > Default* to reset the Test Automation GUI.
- 8 Use the SL1220A AC Emulator drop-down to select the instrument you want to control in this test. If you have configured just one SL1200, then it will be automatically selected.
  - a Leave *Enable Harmonic Control* de-selected (we will not be injecting harmonics during this example).
  - b Check the *Neutral Pass Through* (grounds the neutral).
  - c Set the *Frequency* to either 50 or 60Hz.
  - d Check *Set Voltage/Slew Rate same for all phases* to make programming easier.
  - e Scroll down to the *Phase 1 Settings*, and set the *Voltage* to 231 or 277  $V_{RMS}$ .
  - f Leave the rest of the settings alone. By default the phases are programmed to operate balanced with a 120 degree phase difference.

**NOTE**

If your system is not connected to actual SL12xx hardware, most of these items are grayed-out and not configurable.

- 9 In the Test Plan window, look to the left of the *Configure Three Phase AC Voltage* step. You should see a  icon. Click this icon to expand the test step. The main test step, *Configure Three Phase AC Voltage*, is considered the “parent” step, which executes first before the two tab-delineated steps underneath it which are its “child” steps<sup>1</sup>.
- 10 Click on the child step *Set Three Phase AC Protection Parameters* step. We do not need to edit any of the default values for the example, but note that this is where you can set AC protection trip limits and delays.
- 11 Click on the Test Plan  icon again to open the *Test Steps* box.
  - a Navigate to and expand the *Measure* subsection.
  - b Add a *Start Measurement Log* test step to your test plan.
  - c Now, select it in the *Test Plan* panel to adjust its programmable parameters.
  - d In the *Test Step Settings* panel, make sure the output mode is set to *Independent Three Phase Mode*.
  - e You may change the log file name and location if you desire, otherwise the log will be written to the root of the test automation install directory (*C:\Program Files\Keysight\Test Automation*).
  - f Select the *Choose CSV Log File Parameters* button to open the parameter selection menu.
  - g You can alter the measurements taken, otherwise leave these settings alone for the example. Close the parameters box.
  - h Check the *Add System Info* box to add a header with firmware and serial number information of the SL1200A to the measurement log file.
  - i Keep the *Sample Rate* at 50 ms.
  - j Click the *Choose View 1 Parameter* button to open the View 1 Parameter selection menu. This allows you to select one parameter to graph in a live-viewable panel.
  - k Choose *V1 RMS L-N [V]*. Close the parameter box.
  - l Click on the *Choose View 2 Parameter* button and select another parameter you would like to view such as frequency. Close the parameter box.
  - m Finally, click on the *Choose Data Table Parameters* button to select which parameters should be shown continuously as a table.

**NOTE**

If your system is not connected to actual SL12xx hardware, most of these items are grayed-out and not configurable.

<sup>1</sup> More information on parent and child steps can be found in the Keysight Test Automation Help file under *Help > Getting Started*.

- 12** Go to *View > Panels > Keysight SL1220A* and enable all three panels - **View 1**, **View 2**, and **Data Table**. You should see three floating panels at the middle of the screen. You can keep them floating and move them around to another monitor or part of your screen, or you may “dock” the panels into the UI as you’d like. Make sure to keep these panels visible later when the test plan is running.
- 13** Click on the **+** button once more. Add the **Delay** step. **Delay** is not part of the SL1220A Plugin and is under the *Basic Steps* drop-down in the test steps menu. Program the delay to 5 seconds.

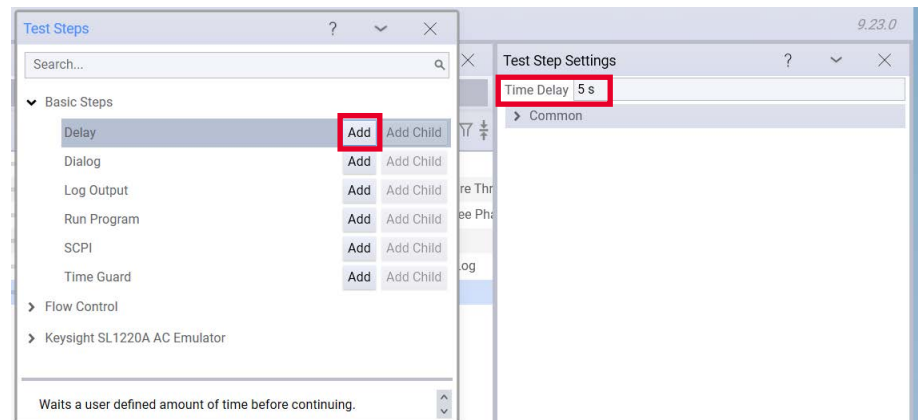

- 14** Add the *Set AC Voltage Output* step from the **Static > AC** subsection of the SL1220A Plugin test step list.
- 15** Set all phases to 277.2 or 332.4  $V_{RMS}$  (20% OV from 231V L-N/400VL-L or 277VL-N/480VL-L).

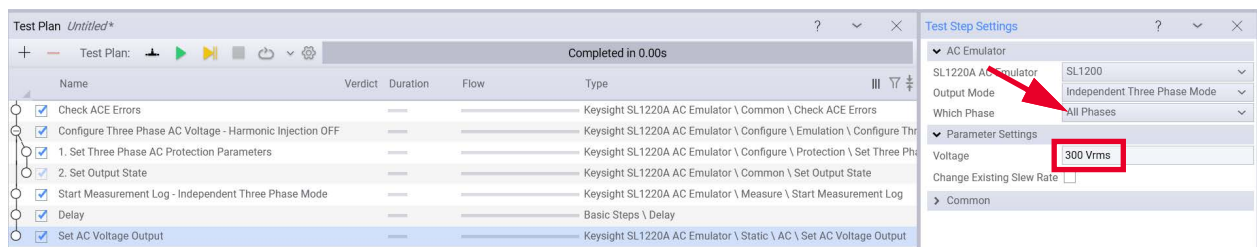

- 16** Check the **Change Existing Slew Rate** box. Set the slew rate to 20  $V_{RMS}/s$ .
- 17** Add another 5 second delay step.
- 18** Add another **Set AC Voltage Output** step. You can add these steps from the *Test Steps* menu, or you can copy-paste existing steps from your test plan and change their values. In the new *Set AC Voltage Output* step, program the output to return to 231 or 277  $V_{RMS}$  with a slew rate of 20  $V_{RMS}/s$  once more.
- 19** Add one more 5 second delay.

**20** Under the *Measure* subsection of the test steps menu, add a **Stop Measurement Log** step. The example test plan is now complete, and should look like the following:

Name	Verdict	Duration	Flow	Type
<input checked="" type="checkbox"/> Configure Three Phase AC Voltage - Harmonic Injection OFF			—	Keysight SL1220A AC Emulator \ Configure \ Emulation \ Configure Three Phase AC Voltage
<input checked="" type="checkbox"/> 1. Set Three Phase AC Protection Parameters			—	Keysight SL1220A AC Emulator \ Configure \ Protection \ Set Three Phase AC Protection Parameters
<input checked="" type="checkbox"/> 2. Set Output State			—	Keysight SL1220A AC Emulator \ Common \ Set Output State
<input checked="" type="checkbox"/> Start Measurement Log - Independent Three Phase Mode			—	Keysight SL1220A AC Emulator \ Measure \ Start Measurement Log
<input checked="" type="checkbox"/> Delay			—	Basic Steps \ Delay
<input checked="" type="checkbox"/> Set All Phases AC Voltage to 0 Vrms at 100 Vrms/s			—	Keysight SL1220A AC Emulator \ Static \ AC \ Set AC Voltage Output
<input checked="" type="checkbox"/> Delay			—	Basic Steps \ Delay
<input checked="" type="checkbox"/> Set All Phases AC Voltage to 0 Vrms at 100 Vrms/s			—	Keysight SL1220A AC Emulator \ Static \ AC \ Set AC Voltage Output
<input checked="" type="checkbox"/> Delay			—	Basic Steps \ Delay
<input checked="" type="checkbox"/> Stop Measurement Log			—	Keysight SL1220A AC Emulator \ Measure \ Stop Measurement Log

## WARNING

**RISK OF PROPERTY DAMAGE AND/OR DEATH: The following example training lab will program the SL1200 to output high voltages capable of injuring or killing a person. Any load or DUT connected to the SL1200 may be damaged if it is not properly rated. The L1, L2, L3, N, G, DC+ and DC- terminals should all be fully disconnected during the example training lab. Please take all proper precautions before proceeding with this exercise**

- 21** Run the test plan. During the runtime, the panels you added earlier should display real-time data from the system. At the end of the test, your view panels should look something like the below.

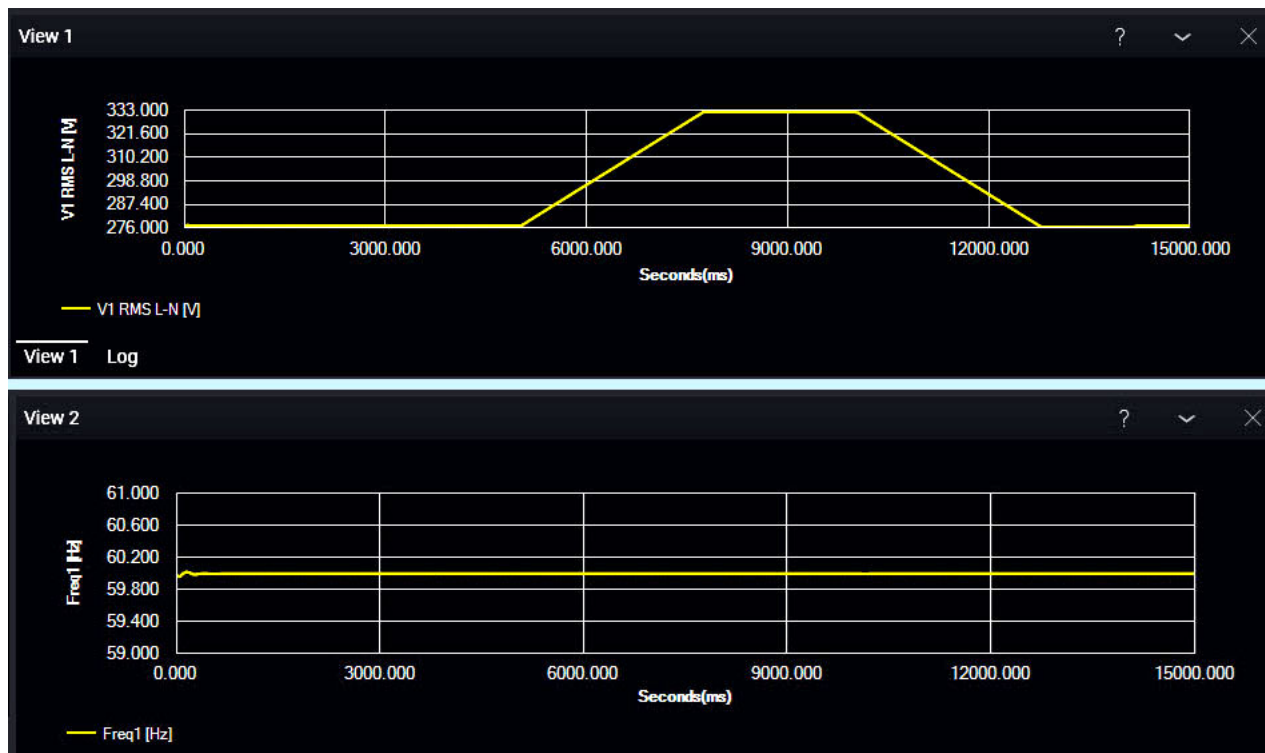

**NOTE**

Step Names, as shown in the screen capture, are modified in the Test Step Settings panel in the Editor. For example, the name “Set All Phases AC Voltage 330 V at 20 Vrms/s” is actually the “Set AC Voltage Output” Test Step from the SL1220A Static subgroup. The Step Name changes according to the settings.

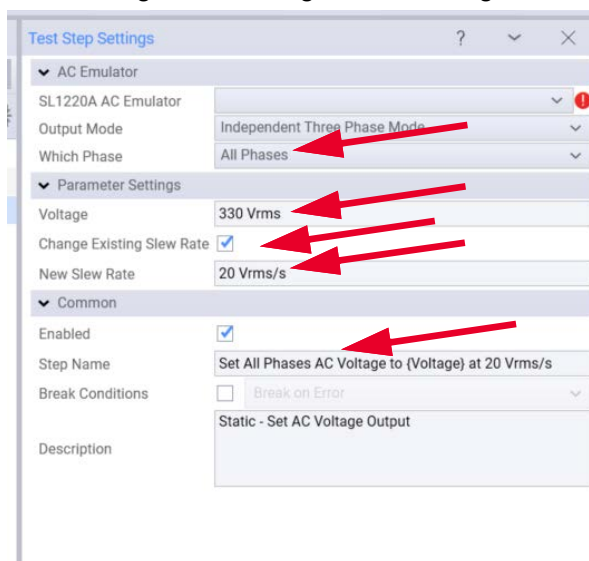

Similarly, the “Wait 500 ms” step is actually another Wait test step but with the Step Name changed according to the specified time.

## Additional SL1220A Example TAP Programs

Additional, complete example Test Plans are located at the default installation location: **C:\Program Files\Keysight\Test Automation\SL1220A Sample Plans**. They will be prefixed with *SL1220A* and with underscore characters instead of spaces in the name (e.g. *SL1220A\_Example\_2\_AC\_Three\_Phase\_Voltage\_Priority*).



# 5 Using the SL1221A PHIL-based Anti-Islanding Compliance Test Automation Plugin

In this chapter:

Equipment and Software Requirements	page 56
Hardware Requirements	page 56
Software Requirements	page 56
Keysight Unintentional Islanding Overview	page 57
An Example Test System for Unintentional Island Tests	page 58
Recommended LAN Configuration	page 59
Steps to Creating an Unintentional Island Test Plan:	page 60
Add and Configure EUT and Test Instruments	page 61
Add a Power Inverter (EUT)	page 61
Add a Power Inverter (EUT)	page 61
Add an AC Grid Emulator and DC Source	page 62
Optional: Add EUT Nameplate Information	page 66
IEEE 1547.1-2020 Conformance Step	page 67
Grid Emulator, EUT, and DC Source	page 68
Create the Test Plan	page 69
Nameplate Test Step	page 70
Section 5.10 Unintentional Island Test Steps	page 71
Section 5.10 Measure Sustained Island Test Step	page 72
Section 5.10 Measure Clearing Time Test Step	page 73
Status Panel	page 74
Running a Test Plan	page 75
Running a Measure Sustained Island Step	page 75
Running a Measure Clearing Time Step	page 78
Measurements and Post Processing Directories	page 82
CSV Measurement Files	page 83
PNG Waveform Files	page 85

**Important:** This chapter provides a brief overview of the **SL1221A PHIL-based Anti-Islanding Compliance Test Automation Plugin** used to run unintentional islanding tests according to IEEE 1547.1-2020. It does not provide complete and detailed instructions. For detailed information, refer to the *SL1200A Grid Integration and Compliance Test Automation Suite Help File*.

## Equipment and Software Requirements

### Hardware Requirements

To fully use the SL1221A PHIL-based Anti-Islanding Compliance Test Automation Plugin you need the following hardware:

- One SL1200A Regenerative AC Emulator such as the SL1212A. Multiple units can be connected in parallel to achieve higher power.
- A DC source such as the Keysight RP7900A or SL1200A Gridf Emulator in DC Emulation Mode (fixed DC only)
- A Power Inverter for the Device Under Test (DUT, also known as an EUT<sup>1</sup>)

Refer to the SL1200A Grid Integration and Compliance Test Automation Suite Help File for more detailed information.

### Software Requirements

- Keysight KS8400B Pathwave Test Automation Platform (TAP) software and license
- SL1200A Integrated Grid Test Automation Suite package and license for the SL1221A PHIL-based Anti-Islanding Compliance Test Automation Plugin

See [“Install SL1200A Grid Integration and Compliance Test Automation Suite”](#) on page 39 for detailed SL1200A package installation information.

#### NOTE

**IMPORTANT licensing information:** The SL1200A Grid Integration and Compliance Test Automation Suite package includes both the SL1220A and SL1221A Plugins. Plugin licenses are mutually exclusive. Test Steps for plugins not licensed are visible but not usable.

You must license the SL1220A plugin to use the SL1220A AC/Grid Test Sequencing Plugin test steps, and you can use them without using any of the SL1221A PHIL-based Anti-Islanding Compliance Test Automation Plugin test steps.

Similarly, you must license the SL1221A PHIL-based Anti-Islanding Compliance Test Automation Plugin to use the IEEE 1547.1-2020 Compliance Test Automation Software Test Steps and you can use them without using the SL1220A AC/Grid Test Sequencing Plugin test steps.

---

<sup>1</sup> "EUT" and "DUT" refer to the same device. EUT is used by IEEE, the SL1221A Plugin, and others to specify the device being tested. DUT is a common term and is used in Keysight's KS8400B.

## Keysight Unintentional Islanding Overview

The following graphic describes the Keysight solution for unintentional islanding. This graphic represents the translation of the unintentional island test procedures, setups, etc., found in the IEEE-1547.1-2020 into the Keysight KS8400B Test Automation Platform (TAP). This TAP environment running the SL1221A TAP Plugin addresses the Section 5.10.2 test requirements. The software runs in the Windows environment and interfaces to the various hardware components via LAN.

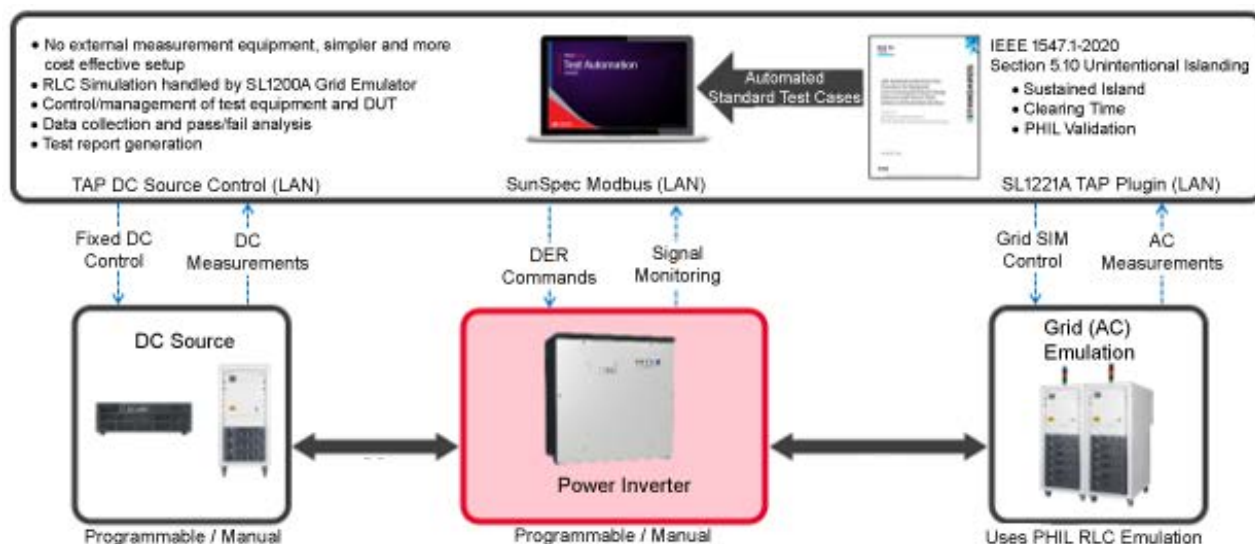

## An Example Test System for Unintentional Island Tests

We will use the SL1221A PHIL-based Anti-Islanding Compliance Test Automation Software plugin to create a sample Unintentional Islanding test plan based on the following system diagram. Your actual test plan may use a different DC Source, AC Grid configuration, or EUT (power inverter) and be different than this example.

The test environment consists of the **Grid Emulator** (a Keysight SL1200 series AC/Grid Emulator), the **Power Inverter** (EUT - Equipment Under Test, or DUT - Device Under Test), and the **DC Source** to power the inverter. Each of these devices must be properly configured (referred to as a “profile”) in the SL1221A plugin before testing can take place. The following illustration shows a Three-Phase (3 $\phi$ ) inverter configuration. However, the SL1221A can also test Single-Phase and Split-Phase inverters as well. For detailed information, refer to the SL1200A Grid Integration and Compliance Test Automation Suite Help File.

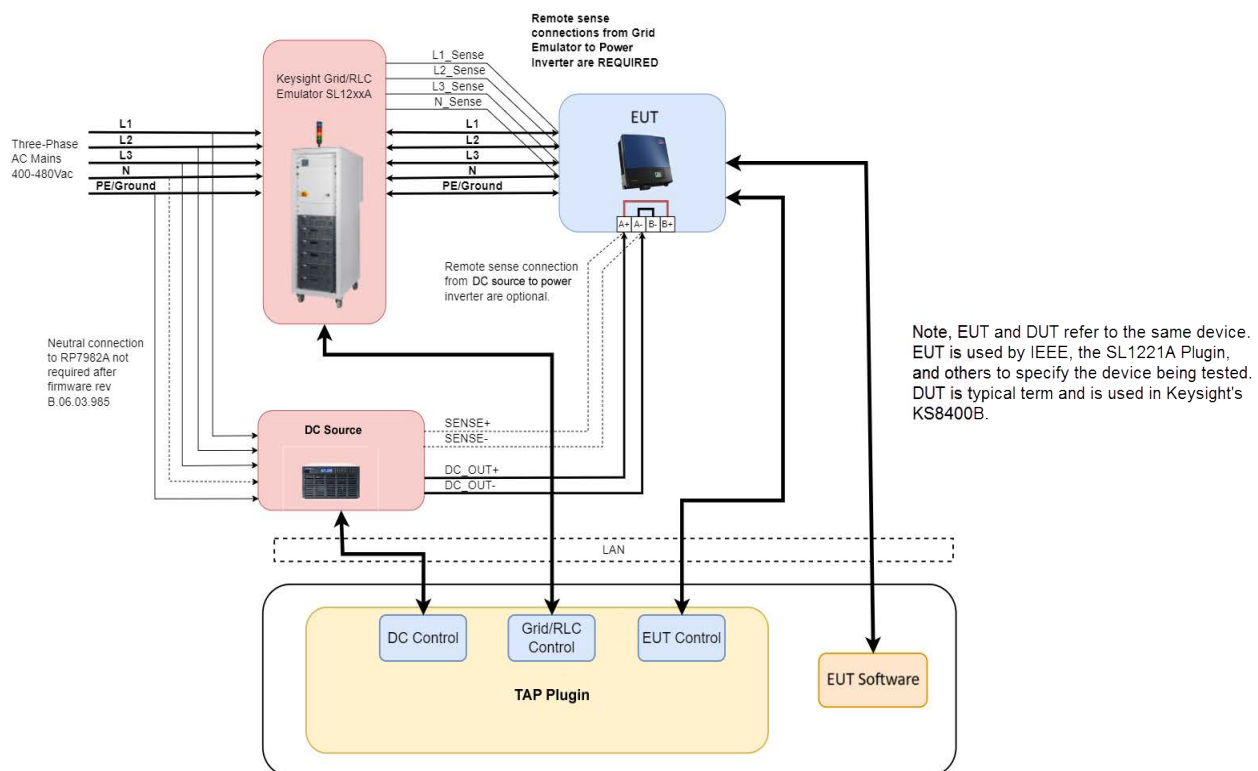

To achieve best performance, the SL1221A Plugin configures the SL1200A AC/Grid Emulation system to always operate in the Three-Phase mode where the user selects the Single, Split, or Three-Phase mode of operation and then wires the Power Inverter to the active L1, L2, L3, and Neutral lines. This allows a single SL1200A AC/Grid Emulator rack system to handle low power Single and Split Phase micro inverters up to relatively high-power Single, Split, and Three-Phase Power Inverters while maintaining its highest output impedance for RLC Autotuning.

The SL1221A plugin controls the SL1200A AC/Grid Emulator and sets up the Power Inverter using either SunSpec ModBus or allows manual control of the inverter.

The DC Source can be virtually any DC Source that works best to power the EUT.

## Recommended LAN Configuration

The SL1200A Grid Emulators make use of UDP Broadcasting for 20kSa/s measurement data during testing. This broadcast data only works if the computer and the SL1200A are on the same subnet. Keysight recommends using a computer with a single LAN interface connected to a LAN Switch and to all the other LAN Devices, as shown below.

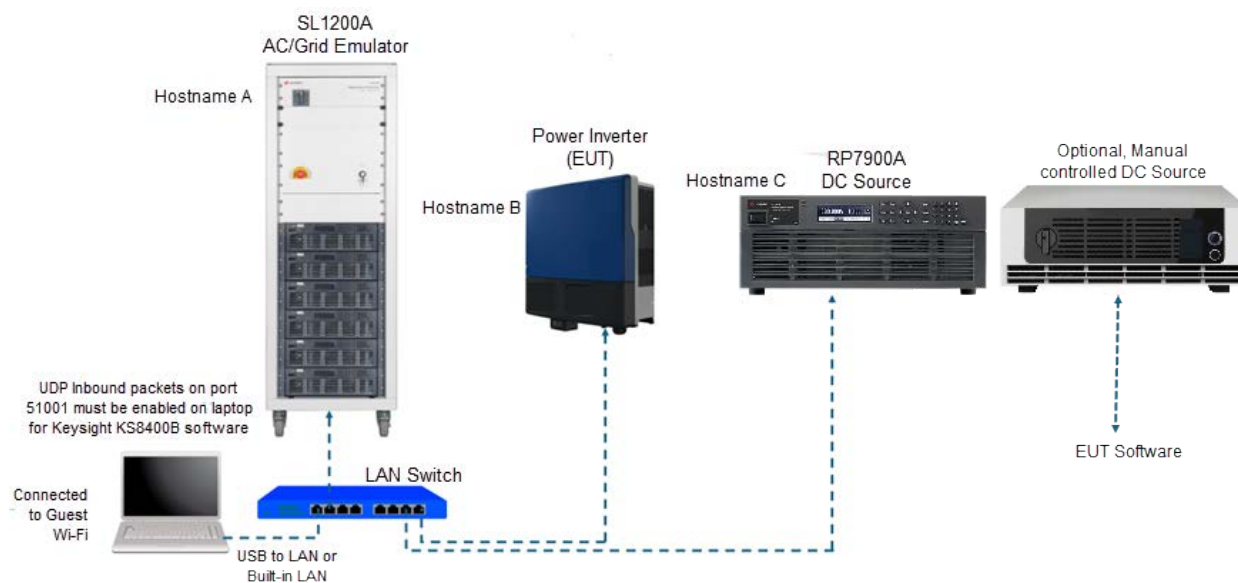

## Steps to Creating an Unintentional Island Test Plan:

- 1** Add and configure the EUT in the TAP Editor
- 2** Add an AC Emulator and DC Source in the TAP Editor
  - Add and configure the AC Emulator
  - Add and configure the DC Source
  - Optionally, add EUT Nameplate Information step
- 3** Add the IEEE 1547.1-2020 Conformance Test Step (known as the Grandparent Test Step)
- 4** Complete Test Step Settings
  - Optional: Add a Title to Your Test Plan. See “Optional: Add a Title to Your Test Plan” on page 33
- 5** Run the Test Plan
- 6** Analyze the Test Data

Keysight’s SL1200A Grid Integration and Compliance Test Automation Suite Help File describes each of these steps in detail.

**NOTE**

**Important:** Create the EUT Profile, Grid Emulator Profile, and DC Source Profile before you add the IEEE 1547.1-2020 Conformance Test Step into the Test Plan. Otherwise, Test Plan errors may occur.

---

## Add and Configure EUT and Test Instruments

Creating the EUT Profile, Grid Emulator, and DC Source are necessary **before** you add the IEEE 1547.1-2020 Conformance Test Step into the Test Plan. Otherwise, you will see red-circle errors (❗) in the Test Plan.

### Add a Power Inverter (EUT)

EUT configuration is essential to properly operate the Grid Emulator and the DC Source. The TAP environment creates a resource called a DUT (or EUT<sup>1</sup>). The EUT Device Profile provides the configuration information. A detailed description of creating profiles for the EUT, Grid Emulator, and DC Source can be found in the SL1200A Help File.

You must specify the EUT (power inverter) you are testing. Multiple EUTs may be created and populated with the correct information. The one to be tested can be selected and used in a Test Plan. The EUT Profile is the starting point for all information and represents the most important source of information to drive the Test Steps.

- 1 Add an EUT by clicking the *DUTs Add New* button in the **Resources** panel at the bottom of the Test Automation window. Alternately, select *Settings > Bench > DUTs* to open the DUTs tab in the **Bench Settings** panel.
- 2 Select the **DUTs** tab in the Bench Settings panel. Then click the **+** icon. This opens the **Add New DUT** panel.
- 3 If necessary, expand the *IEEE 1547.1-2020 Conformance Test Equipment*.
- 4 Select **Power Inverter**, then click the **Add** button.

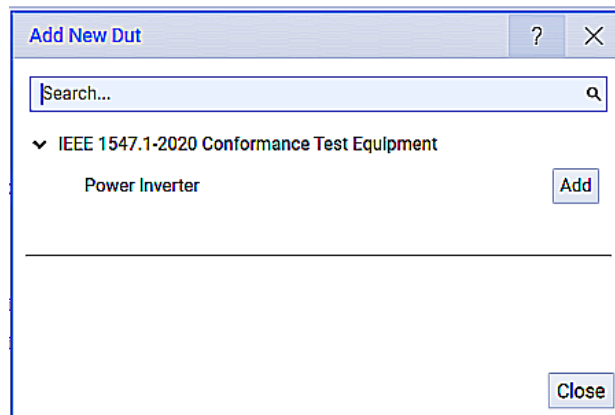

This adds a Power Inverter as a DUT device in the KS8400B Resources panel and automatically opens the DUT Bench Settings panel.

<sup>1</sup> IEEE and other industries use EUT to specify the device being tested. Keysight's KS8400B uses "DUT", this is the same as an "EUT".

- 5 After adding a **DUT**, complete the Bench Settings panel with all necessary information about the power inverter to ensure proper communication. For detailed information, refer to the **DUT Bench Settings** panel in the SL1220A Help File.
- 6 It is possible to have multiple DUT devices specified in the SL1221A Plugin. Once added with the default name as power inverter, you can double-click the named device on the left side to rename it.

## Add an AC Grid Emulator and DC Source

For the Test Plan to be functional, resource configuration is necessary. You must add both an AC Emulator and a DC Source that powers the power inverter. You have several choices for each of these.

For this example, select a Keysight SL1200A Series Regenerative AC/Grid Emulator and a Keysight RP7900 DC Source. Note that these are configured in the **Add New Instrument** panel.

- 1 Add an instrument by clicking the Instruments *Add New* button at the bottom of the Test Automation window. Alternately, you can select *Settings > Bench > Instruments* to open the Instruments tab in the Bench Settings panel.

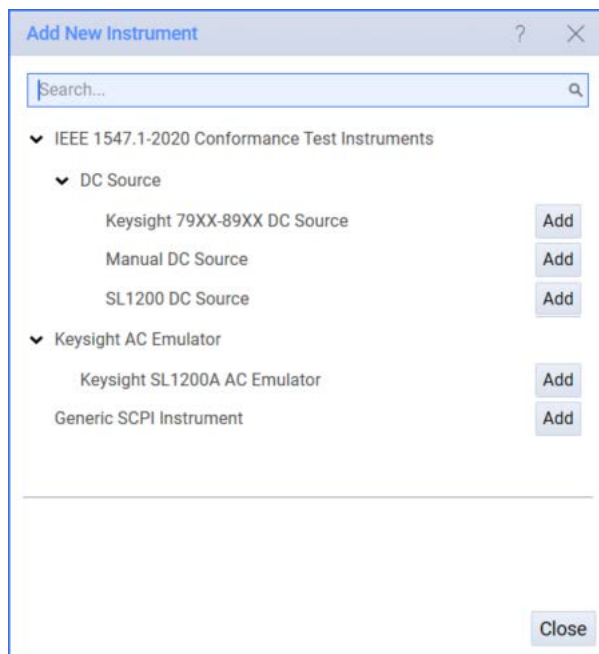

- 2 Select the **Instruments** tab in the Bench Settings panel then click the **+** icon. This opens the **Add New Instruments** panel in front of the Bench Settings panel.
- 3 Expand the *IEEE 1547.1-2020 Conformance Test Equipment > DC Sources* to show possible DC Sources.

- 4 Expand the *Keysight AC Emulator* to show the Keysight SL1200A Series Regenerative AC/Grid Emulator.

### Add an AC Grid Emulator

The SL1221A TAP Plugin supports the SL1200A Series of Grid Emulators:

SL1201A 600 VL-L, 63 A, 30 kW / 42 kVA

SL1202A 600 VL-L, 63 A, 45 kW / 66 kVA

SL1203A 600 VL-L, 125 A, 90 kW / 130 kVA

SL1212A 1200 VL-L, 32.5 A, 45 kW / 68 kVA

SL1213A 1200 VL-L, 65 A, 90 kW / 135 kVA

SL1214A 600 / 1200 VL-L, 65 / 32.5 A, 45 kW / 68 kVA

SL1215A 600 / 1200 VL-L, 130 / 65 A, 90 kW / 135 kVA

The two models in [Blue](#) have Dual Range operation, where they can represent the other five models' voltage range programmatically.

Models come with three or six Power Stages and up to nine voltage-range AND same-power systems can be paralleled together. Power Stages are paralleled together per AC phase.

Refer to [SL1200A Series Scienlab Regenerative AC Emulator](#) for detailed information. Also, refer to the SL1200A Grid Integration and Compliance Test Automation Suite Help File for more detailed information.

- 1 For this example, select the *Keysight SL1200A AC Emulator* then click the **ADD** button. This opens the **Bench Settings** panel.

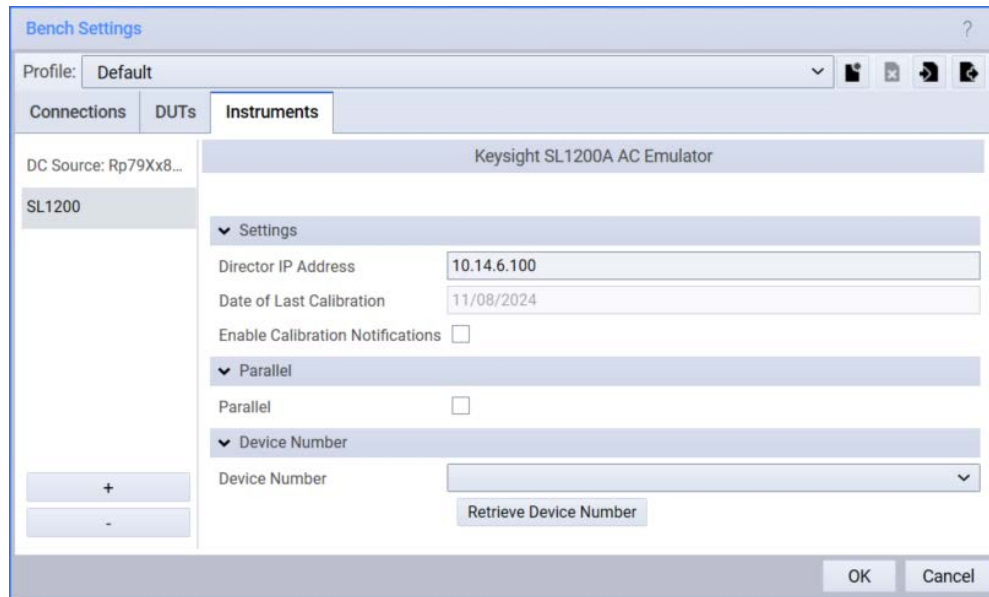

- 2 Complete the **Bench Settings** panel with *Director IP Address*, etc. to ensure proper communication with the SL1200A. For detailed information, refer to the **AC Emulator Bench Settings** panel in the SL1220A Help File.
- 3 Click the *Retrieve Device Number* button to select or specify exactly which model of the SL1200A series is used for the test. The SL1200A AC Emulators come with a Soft Front Panel that can be used to discover any SL1200A Systems on the LAN your PC is connected. If installed on your PC, it can be found typing SL1200A into your Windows Search box, which should bring up the following and then selecting its Help File for assistance

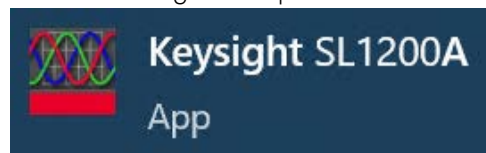

### Add a DC Source

This document describes ways of changing the AC Output Power of the EUT by manually controlling the DC Power Supply. This gives maximum flexibility in choosing a DC Power Supply for powering the EUT.

You can add one or more DC Sources.

- 1 For this example, select the **Keysight RP79Xx89Xx DC Source**. Click the **ADD** button.

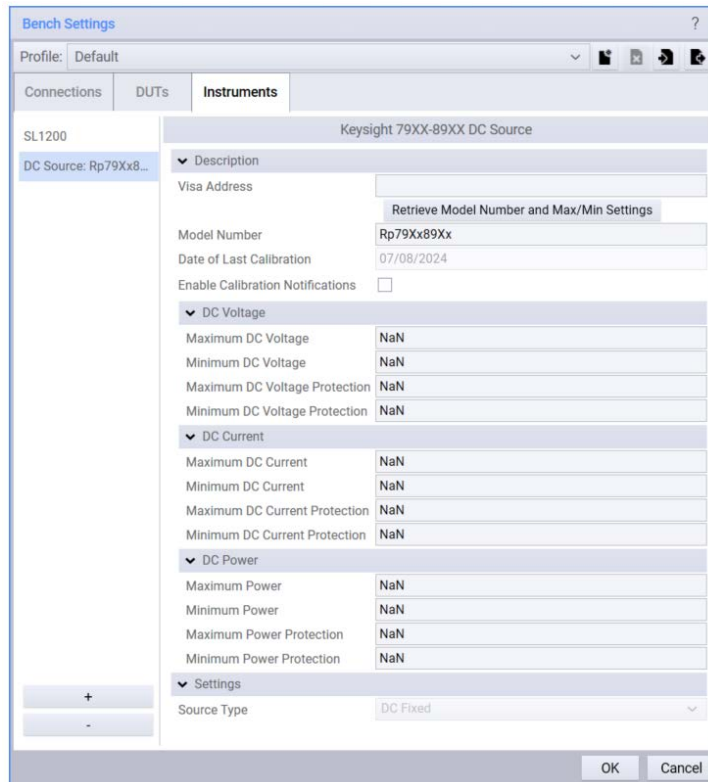

- 2 Fill in the **Bench Settings** panel with all necessary information about your DC source to ensure proper communication. For detailed information, refer to the **DC Source Bench Settings** panel in the SL1220A Help File.
- 3 Parameters shown are compared when trying use the DC Source during testing. If the DC Power is insufficient for the needs of testing the EUT, this is flagged in the Equipment Screening step. Equipment Screening is enabled in Test Steps Settings panel of the 5.10.2 Unintentional Island Test Step.

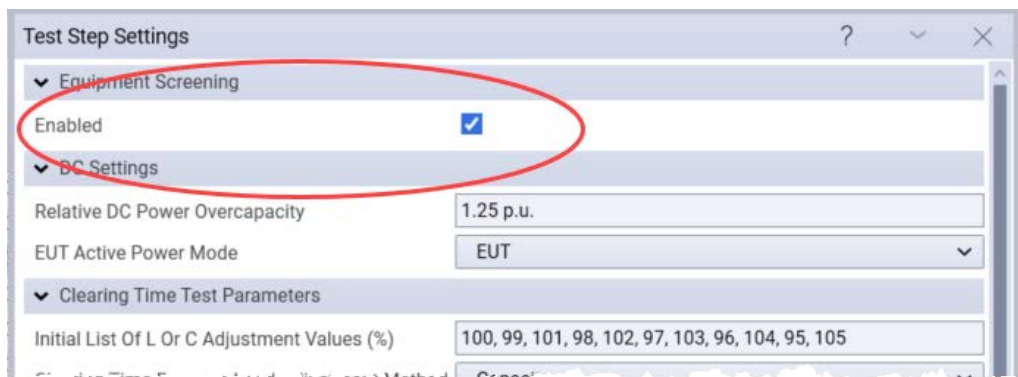

**NOTE**

Keysight's SL1200A Grid Emulator can be configured as a DC Source too. However, the SL1200A cannot provide PhotoVoltaic (PV) Simulation. Therefore, if you must operate the EUT in MPP mode, you need to provide a DC Source that has PhotoVoltaic (PV) Simulation, such as Keysight's RP79xx/RP89xx series power supplies or any other DC Source that is controlled manually.

## Optional: Add EUT Nameplate Information

After adding the EUT to the Resources, you can include a test step to automatically add the EUT Nameplate information. This information is used to verify connectivity and assist troubleshooting.

This Test Step must go before the IEEE 1547.1 Conformance Test Step (the Grandparent step).

- 1 In the Test Automation editor, click the **+** button (or press **Ctrl+T**) to open the Test Steps panel.
- 2 Expand *EUT Control* > *Common*.
- 3 Select *Nameplate Information* then click the **Add** button to insert the *Nameplate Information* panel.

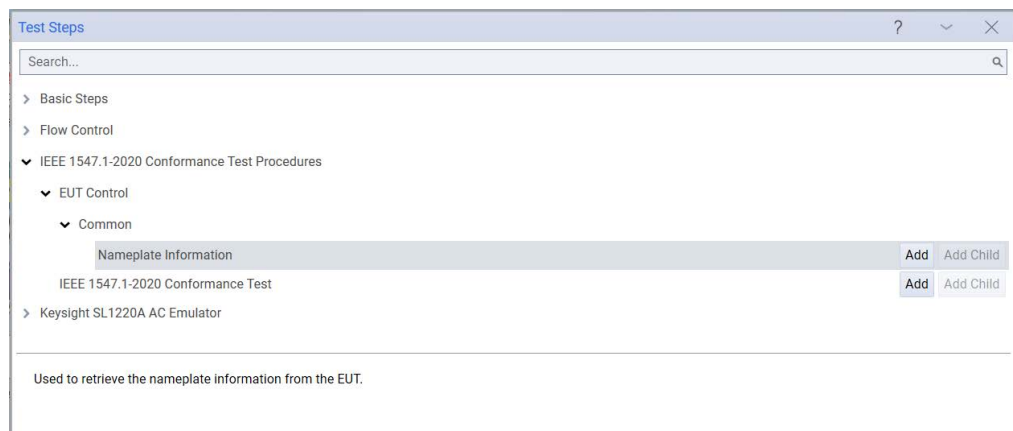

Note that the Nameplate Test Step can specify which EUT it is query, but you MUST provide your own power to the EUT for the command to work. That is, the Step does NOT provide power to the EUT as it does with the IEEE 1547.1-2020 Conformance Test Grandparent Step.

This can be easily done by using the SL1200A Soft Front Panel and executing the Nameplate Test Step by itself in the TAP Test Plan.

For detailed information about the Nameplate Panel, see [“Nameplate Test Step”](#) on page 70.

## IEEE 1547.1-2020 Conformance Step

Only a single step - called the IEEE 1547.1-2020 Conformance Test or Grandparent Step -- represents the complete IEEE 1547.1-2020 test. This step is called the “Grandparent” step<sup>1</sup>, because there are multiple sub-steps involved:

- IEEE 1547.1-2020 Conformance Step. This is the top-level Step from which all Test Type Steps are run.
- Section 5.10 Unintentional Island Test, known as the ‘Parent’ step
  - Section 5.10.2 Measure Sustained Island Tests, known as ‘Child’ steps
  - Section 5.10.2 Measure Clearing Time Tests, known as ‘Child’ steps

The screenshot shows the Keysight Test Automation interface with a test plan titled 'Untitled\*'. The test plan is completed in 0.00s. The test plan structure is as follows:

Name	Verdict	PostProcessorWaitTime	Duration
IEEE 1547.1-2020 Conformance Test	Pass	---	---
Section 5.10 Unintentional Island Test	Pass	---	---
Section 5.10.2 Measure Sustained Island: RMS Voltage = 1 p.u., Frequency Offset = 0 Hz	Pass	---	---
Section 5.10.2 Measure Sustained Island: RMS Voltage = 0.9 p.u., Frequency Offset = -1.3 Hz	Pass	---	---
Section 5.10.2 Measure Sustained Island: RMS Voltage = 0.9 p.u., Frequency Offset = 1 Hz	Pass	---	---
Section 5.10.2 Measure Sustained Island: RMS Voltage = 1.05 p.u., Frequency Offset = -1.3 Hz	Pass	---	---
Section 5.10.2 Measure Sustained Island: RMS Voltage = 1.05 p.u., Frequency Offset = 1 Hz	Pass	---	---
Section 5.10.2 Measure Clearing Time: Test Case 1B, Active Power = 1 p.u., Reactive Power = 0 p.u.	Pass	---	---
Section 5.10.2 Measure Clearing Time: Test Case 2B, Active Power = 0.5 p.u., Reactive Power = 0 p.u.	Pass	---	---
Section 5.10.2 Measure Clearing Time: Test Case 3B, Active Power = 0.9 p.u., Reactive Power = -0.44 p.u.	Pass	---	---
Section 5.10.2 Measure Clearing Time: Test Case 4B, Active Power = 0.9 p.u., Reactive Power = 0.44 p.u.	Pass	---	---
Section 5.10.2 Measure Clearing Time: Test Case 5B, Active Power = 1 p.u., Reactive Power = 0 p.u.	Pass	---	---
Section 5.10.2 Measure Clearing Time: Test Case 6B, Active Power = 0.5 p.u., Reactive Power = 0 p.u.	Pass	---	---
Section 5.10.2 Measure Clearing Time: Test Case 7B, Active Power = 0.5 p.u., Reactive Power = 0 p.u.	Pass	---	---
Section 5.10.2 Measure Clearing Time: Test Case 8B, Active Power = 1 p.u., Reactive Power = 0 p.u.	Pass	---	---
Section 5.10.2 Measure Clearing Time: Test Case 9B, Active Power = 0.5 p.u., Reactive Power = -0.44 p.u.	Pass	---	---
Section 5.10.2 Measure Clearing Time: Test Case 10B, Active Power = 0.5 p.u., Reactive Power = 0.44 p.u.	Pass	---	---

Red boxes and arrows on the left side of the screenshot label the hierarchy:

- Grandparent Step: Points to the top-level test plan.
- Parent Step: Points to the Section 5.10 Unintentional Island Test.
- Child Steps: Points to the individual Section 5.10.2 tests.

<sup>1</sup> It is also called a “Macro” step because there are multiple steps involved in this one step.

## Grid Emulator, EUT, and DC Source

This IEEE 1547.1-2020 Conformance or Grandparent Test Step is the step where you select which Resources are used in the test and you can view the name of the **Results** directory: *IEEE-1547.1 Results Directory* (the name is not editable).

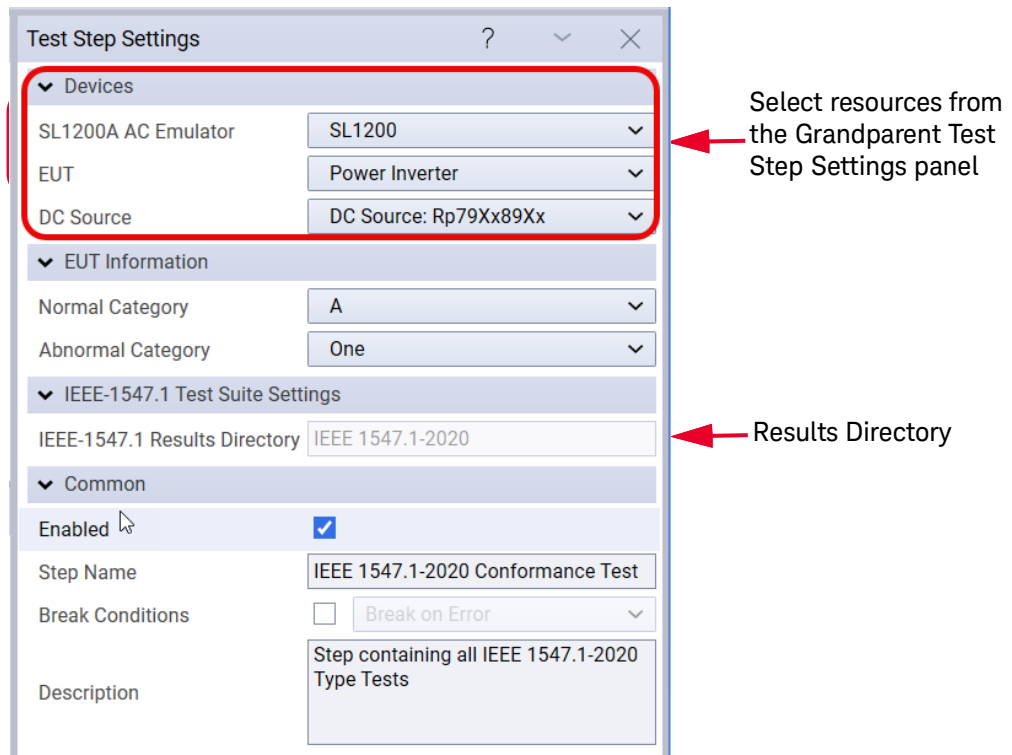

When this Test Step or any step under this one is run, the following directory path is either selected or created:

`C:\TEMP\My_Power_Inverter_Results\IEEE 1547.1-2020`

Steps (Parent or Child steps) below this have additional unchangeable directory names.

The `C:\TEMP\My_Power_Inverter_Results\` comes from the EUT Profile page and called the **Data Logging Directory**.

The Grid Emulator, EUT, and DC Source are selected from the top level Grandparent Step Test Step Settings Panel:

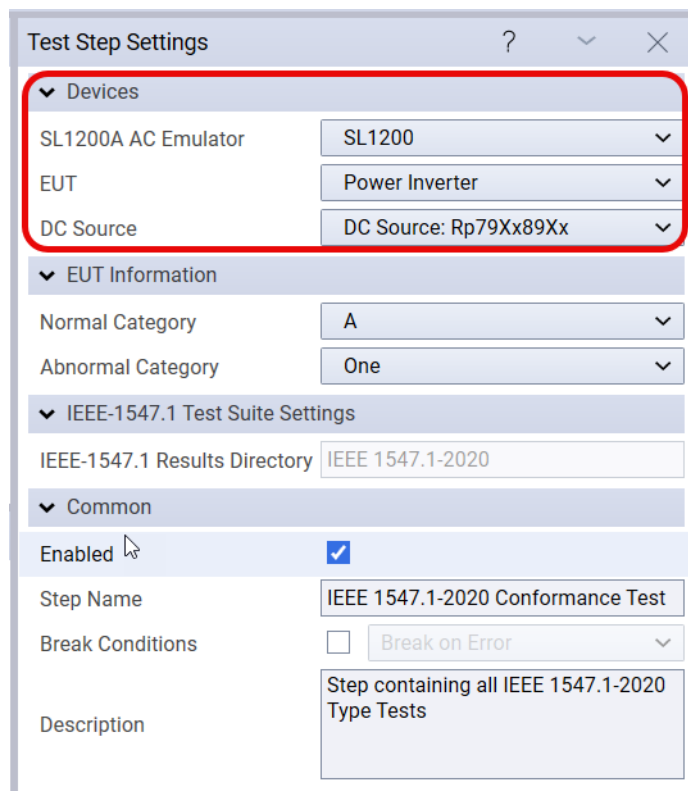

Test Step Settings	
▼ Devices	
SL1200A AC Emulator	SL1200
EUT	Power Inverter
DC Source	DC Source: Rp79Xx89Xx
▼ EUT Information	
Normal Category	A
Abnormal Category	One
▼ IEEE-1547.1 Test Suite Settings	
IEEE-1547.1 Results Directory	IEEE 1547.1-2020
▼ Common	
Enabled	<input checked="" type="checkbox"/>
Step Name	IEEE 1547.1-2020 Conformance Test
Break Conditions	<input type="checkbox"/> Break on Error
Description	Step containing all IEEE 1547.1-2020 Type Tests

Having selected the EUT Three-Phase, all of the Measure Steps configure the Grid Emulator for Three-Phase operation.

**NOTE**

This Step is used to specify the Normal and Abnormal Categories of the Power Inverter. These settings affect almost every Child Step setting in configuring the EUT for proper operation.

## Create the Test Plan

With the DUT, Grid Emulator, and DC Source profiles created, a Test Plan can be created. The Test Plan comes from adding Test Steps into the Test Plan Area.

## Nameplate Test Step

Under the EUT Control/Common folder, there is a Test Step called Nameplate Information. This Step is useful to make sure you can communicate with the EUT over SunSpec ModBus. Add this step as follows:

### NOTE

**EUT Control > Common > Nameplate Information Test Step** should only be added **BEFORE** the Grandparent step or **AFTER** the last Child step beneath the Grandparent step. You can run the Nameplate Information Test Step by itself by right-clicking on it and selecting Run Selected Test Steps or pressing F10. You **MUST** power the EUT separately, since this Step does **NOT** configure the AC or DC Source to power the EUT. Some EUTs can power from either AC or DC. If you have an SL1200A Grid Emulator or DC Source, you can use the SL1200A Soft Front Panel to power the EUT.

- 1 In the Test Automation editor, click the  button (or press **Ctrl+T**) to open the **Test Steps** panel.
- 2 Expand **EUT Control > Common**.
- 3 Select **Nameplate Information** then click the **Add** button to insert the Nameplate Information Test Step.

If your EUT is powered **ON**, you can press the green arrow key  or right-click the **Nameplate Information** step and select **Run Select Test Steps**.

Once executed, the results display in the **Test Step Settings**.

## Section 5.10 Unintentional Island Test Steps

This step, called the “Parent Step” specifies parameters that affect all the child Steps that follow. Also, the initial settings of this Step are affected by its Parent Step - which specifies the Normal and Abnormal Categories. The following shows the Test Step Settings for this Parent Step:

Section	Parameter	Value
Equipment Screening	Enable	<input type="checkbox"/>
	DC Settings	
DC Settings	Relative DC Power Overcapacity	125 %
Clearing Time Test Parameters	Initial List Of L Or C Adjustment Values (%)	100, 99, 101, 98, 102, 97, 103, 96, 104, 95, 105
	Clearing Time Reactive Load Adjustment Method	Capacitor
Analysis - Clearing Time Tests	Clearing Time Specification	2 s
	Clearing Time Warning Threshold	60 %
	Clearing Time Settling Band	5 %
	Number Of Points In Bell Curve Trend Lines	4
Analysis - Sustained Island Tests	Sustained Island Time Specification	10 s
	Sustained Island Stop Band	50 %
Analysis - Operating Tolerances	Frequency Tolerance	100 mHz
	Voltage, Current, and Power Tolerance	5 %
	Gross RLC Tolerance	40 %
	S3 Current/Power Tolerance	2 %
	THD Tolerance	3 %
	TRD Tolerance	5 %
Run Settings	Pause Before Island	<input type="checkbox"/>
Data Logging	Type Test Directory Name	5.10.2
Island Trigger Output Settings	Trigger Out Polarity	Positive
	Trigger Out Pulse Width	50 us

The default settings are according to the IEEE 1547.1-2020 Standard. You are allowed to change many of them, and the changes will be reflected in the Test Plan and in the Report. For example, if you wanted to see how well the EUT is operating, you could lower the Operating Tolerances from 5% to 3% to see if the EUT passes that stricter requirement. However, a Red circle (⚠) will appear next the parameter changed, and the Test Report will reflect the change to the Standard. It would be up to the auditor of the test results to determine if any changes invalidate the test results.

## Section 5.10 Measure Sustained Island Test Step

When running one of these five Steps for the first time, the software prompts you to turn the Anti-Island Algorithm **OFF** in the Power Inverter. You don't want the Power Inverter to shut down within the specified two second time period. You want the Island to persist when the SL1221A RLC emulation matches the impedance of the Power Inverter.

If running in the EUT Manual mode (under the EUT profile), the software prompts you to configure the EUT to default Test Case . Otherwise, with EUT SunSpec ModBus operation, the EUT is automatically configured to these settings.

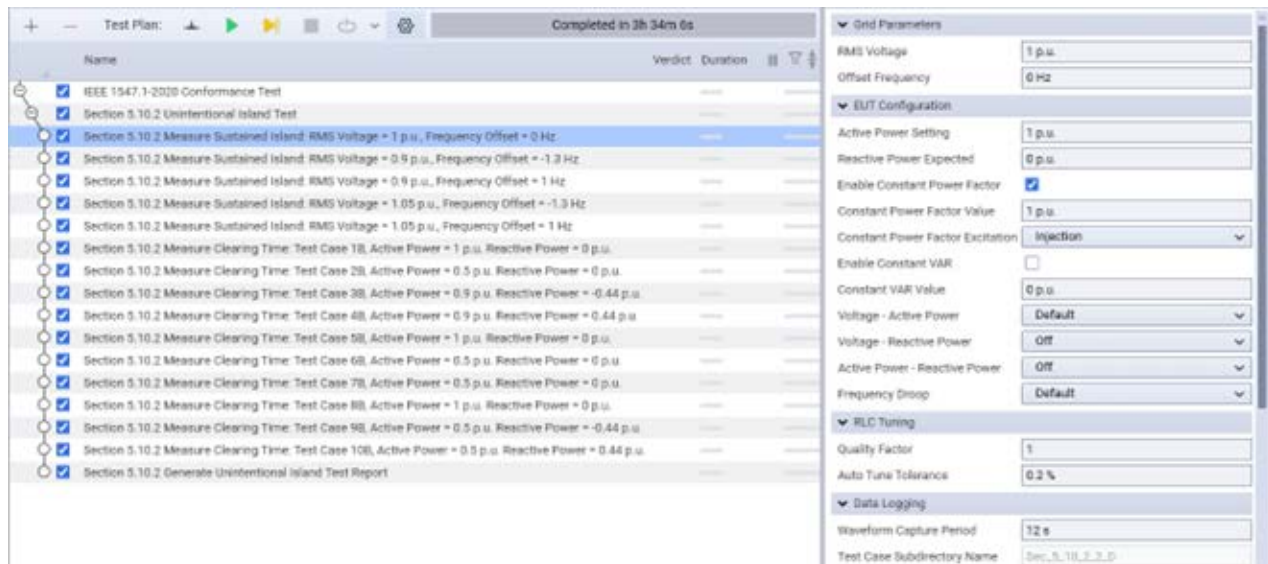

This Sustained Island Step specifies parameters that affect its operation. There are five Sustained Island Test Steps, and many of the parameters are changed dependent upon the type of test to be conducted. The first Step defaults to the Test Case 1 configuration. The remainder of the Sustained Island steps push out the limits of voltage and frequency, so you can test the four corners of Voltage and Frequency. Only parameters you should be concerned with are as follows:

- **Waveform Capture Period:** For Sustained Island, the PHIL controlled environment must create an island that lasts at least 10s. The test fails if island does not sustain itself for at least 10 seconds.
- **Pause While In Island:** Normally, the test only lasts for the about 14s. If you want the Grid Emulator to pause after the island event is triggered, check this box, and the island condition lasts as long as possible for external measurement evaluation of Voltage and Frequency, which should be very close to the Grid Voltage and Frequency initially applied. However, now the Voltage and Frequency are the result of the matched RLC impedances, which will be slightly different than the original Grid signals.

The **Step Status** panel in the Test Step Settings for each Step shows the progress of the particular Step when it is executing. Selecting this Step while Running permits you to visualize the *Step Status* information in detail. Key information is also represented in the **Test Step Status Panel** along with the real measurements being made during the test sequence.

## Section 5.10 Measure Clearing Time Test Step

When running one of these ten Steps for the first time, the software prompts you to turn the Anti-Island Algorithm **ON** in the Power Inverter. That is, you want the Power Inverter to shut down within the specified 2 second time period if the Grid goes away.

When running in the EUT Manual mode, the system prompts to configure the EUT to the appropriate setting for the particular test case, category, and operating modes, as specified in the EUT Profile. Otherwise, with EUT SunSpec ModBus operation, the EUT is automatically configured for you..

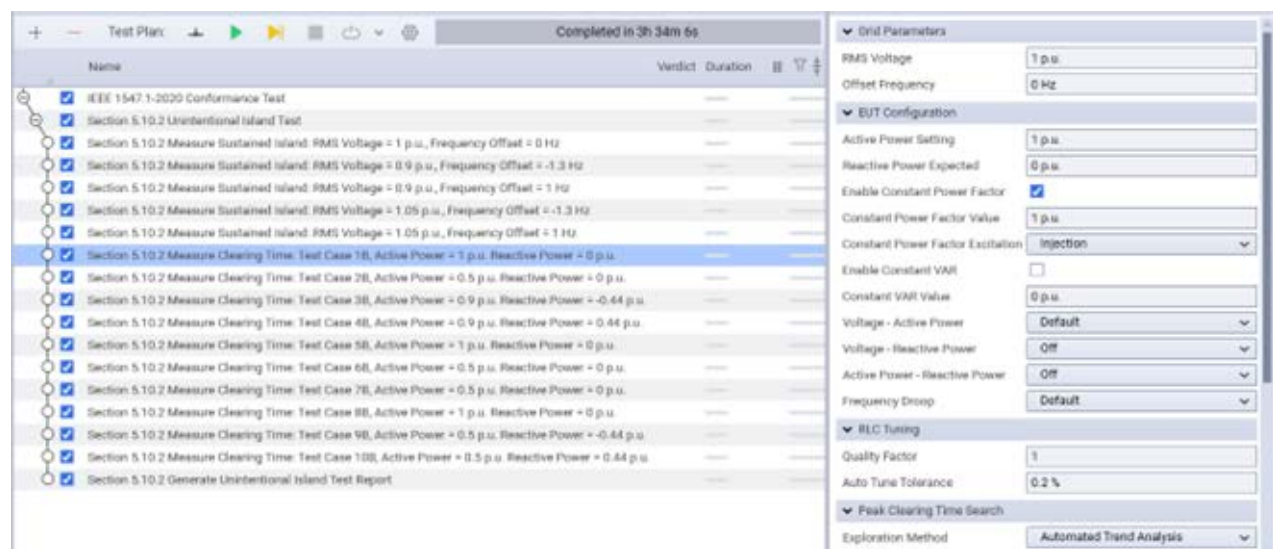

The Measure Clearing Time Step specifies parameters that affect its operation. There are ten Measure Clearing Time Test Steps, and many of the parameters are changed dependent upon the type of test to be conducted. Only parameters you should be concerned with are the Exploration Methods:

- **Exploration Method:** Default is Automated Trend Analysis, where the percentage points list (specified in the Parent Step) is implemented, and any additional points are automatically added to meet the other requirements in the Parent Step. For example, the Trend Analysis in the Parent Step specifies there must be at least 4 Exploration Points to the Right and Left of the highest clearing time point. If there are only 3 on the Right side of the "Bell Curve" after running through percentage points 95-105%, then point 106% is added. This continues until the criteria is met.

The other option is Manual Search, where a prompt will be given after traversing the Percentage List found in the Parent Step. You can then add your own percentage points.

- **Waveform Capture Period:** For Clearing Time, the Power Inverter must shut down within 2s. The test fails if the island does not cause a trip in less than 2 seconds for any specified percentage point.

The **Step Status** in the Test Step Settings shows the progress of this particular Step when it is executing. Selecting this Step while Running permits you to visualize this information.

This information is also represented in the **Test Step Status Panel** along with the real measurements being made at each sub-step.

## Status Panel

The Status Panel is constantly updated as each test runs. You can watch and monitor test progress by watching the Status Panel.

Test Step Status			
<b>EUT Measurements</b>			
	Phase 1	Phase 2	Phase 3
Urms (L-N)	277.15 V	276.72 V	276.72 V
Irms	14.48 A	14.47 A	14.45 A
Real Power (P)	4.00 kW	4.00 kW	4.00 kW
Reactive Power (Q)	-55.39 var	-57.85 var	-60.28 var
Apparent Power (S)	4.01 kVA	4.01 kVA	4.01 kVA
Power Factor	-1.00	-1.00	-1.00
Frequency	60.00 Hz	60.00 Hz	60.00 Hz
<b>DC Source Measurements</b>			
Voltage	775.00 V		
Current	15.76 A		
Power	12.24 kW		
<b>Tuned RLC Emulation Calculations</b>			
S3 Irms	0.00 A	0.00 A	0.00 A
Resistance	0.00 Ω	0.00 Ω	0.00 Ω
Inductance	0.00 mH	0.00 mH	0.00 mH
Capacitance	0.00 μF	0.00 μF	0.00 μF
<b>Progress Information</b>			
Step Stage Of Operation	Waiting for EUT Power to reach expected value		
Iteration Percent	N/A		
Iteration Status	N/A		
Remaining Percent Points	N/A		
Steady State Reached	Incomplete		
RLC Elements Tuned	Incomplete		
S3 Open/Island Enabled	Incomplete		
Power Per Phase: (Pref,Qref)	( 5.00 kW, 0.00 kvar ) => 80.0 %		

Shows the measured values of the AC Emulator during the tests. For Split-Phase configuration, only Phase 1 and Phase 2 should show active results.

DC Source measurements show the Power Inverter is in regulation and that it requires 12.24 kW of DC power to produce the 4 kW AC power per phase.

At this power level, these would be the RLC components necessary to cause a proper island condition after auto tuning.

At the time this panel was captured, the RLC values had not been calculated and the island event had not taken place.

These are the expected steady-state Real power and Reactive power settings per phase for this test.

## Running a Test Plan

It is recommended that you run all five Measure Sustained Island Steps individually or as a group. It is also recommended that you run each Measure Clearing Time Step individually. Although the 10 Clearing Time Steps can be run automatically, you are likely to see issues with proper operation if this is the first time you have run the Step. Running them individually will give you confidence they are working properly, so you don't have to abort the Test Plan to stop all testing when one Step is not working properly. Therefore, right-click on any of the 10 lower-level Steps and select Run Selected Test Steps.

### Running a Measure Sustained Island Step

You will be prompted to turn **OFF** the Anti-Island and any other mode that might cause the Power Inverter to shut OFF automatically. If you are running multiple Sustained Island Step in sequence, you will only see the following Dialog once.

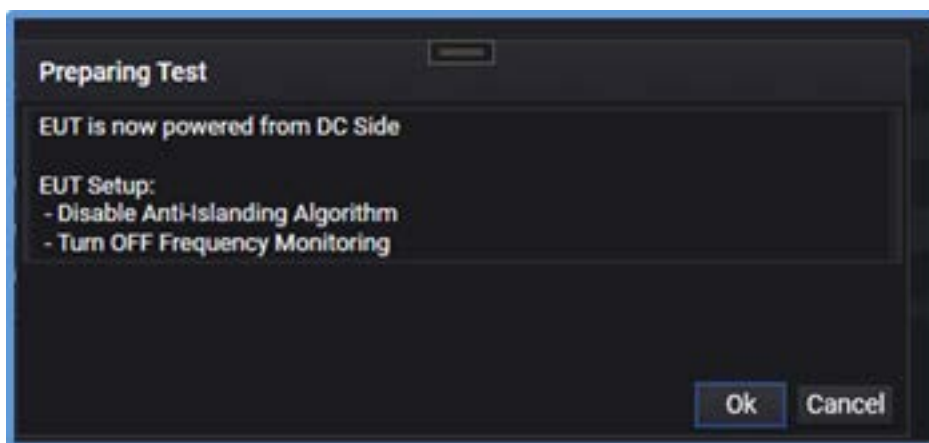

In Manuel EUT Mode (from the EUT profile), you will also be asked to configure the Power Inverter for either the specified test case or to turn off all voltage and frequency limits. For example, here is the Dialog for the remaining four Sustained Island Steps.

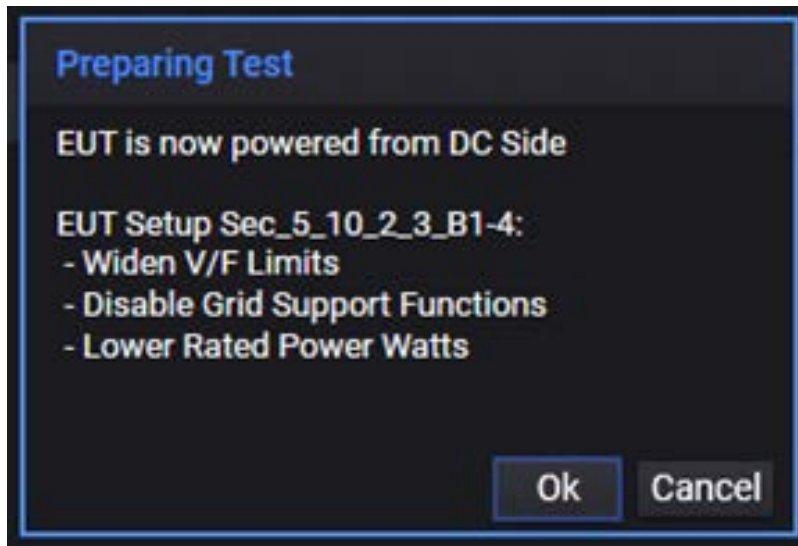

When the Measure Sustained Island Test Step is running, the Test Step Status panel shows the settings, measurements, and progress

**Test Step Status**

**EUT Measurements**

	Phase 1	Phase 2	Phase 3
Urms (L-N)	0.59 V	0.56 V	1.18 V
Irms	0.00 A	0.00 A	0.00 A
Real Power (P)	0.00 kW	0.00 kW	0.00 kW
Reactive Power (Q)	0.00 var	0.00 var	0.00 var
Apparent Power (S)	0.00 kVA	0.00 kVA	0.00 kVA
Power Factor	0.00	0.00	0.00
Frequency	30.00 Hz	47.31 Hz	30.00 Hz

**DC Source Measurements**

Voltage	1.91 V
Current	0.00 A
Power	0.00 kW

**Tuned RLC Emulation Calculations**

	Phase 1	Phase 2	Phase 3
S3 Irms	0.00 A	0.00 A	0.00 A
Resistance	15.21 Ω	15.21 Ω	15.23 Ω
Inductance	41.52 mH	41.53 mH	41.64 mH
Capacitance	179.37 μF	179.53 μF	179.61 μF

**Progress Information**

Step Stage Of Operation	Completed
Iteration Percent	N/A
Iteration Status	N/A
Remaining Percent Points	N/A
Steady State Reached	Complete
RLC Elements Tuned	Complete
S3 Open/Island Enabled	Complete
Power Per Phase: (Pref,Qref)	( 5.00 kW, 0.00 kvar ) => 99.1 %

**Sustained Island Results**

Step Name:

Selected File:

Clearing Time Results | **Sustained Island Results** | Test Step Settings

When this Step finishes, it Passed with a Green banner, and the Measure Sustained Island Panel shows the results – that the Sustained Island lasted for at least 10 seconds:

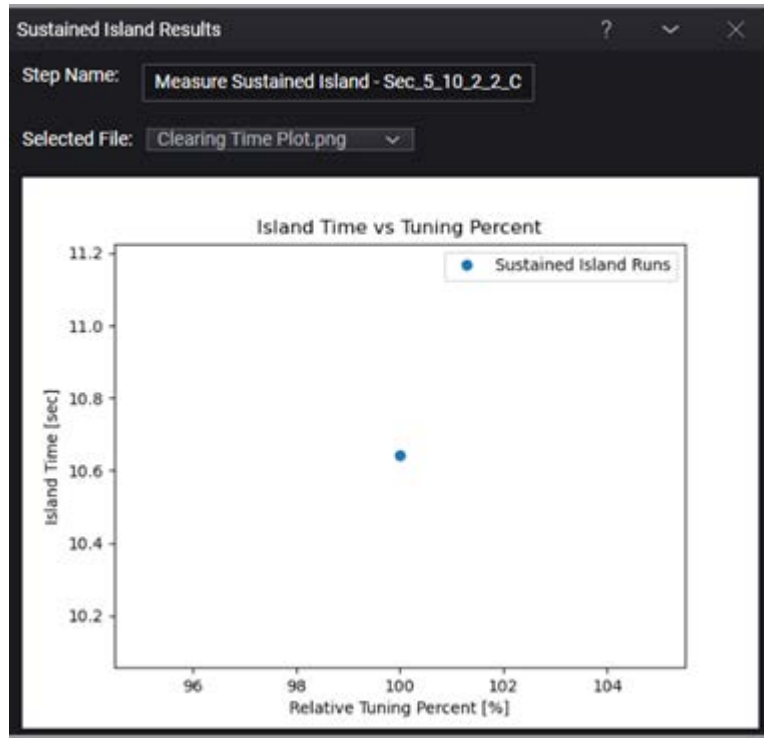

## Running a Measure Clearing Time Step

You will be prompted to turn **ON** the Anti-Island and any other mode that might cause the Power Inverter to shut OFF automatically. If you are running multiple Measure Clearing Time Steps in sequence, you will only see the following Dialog once.

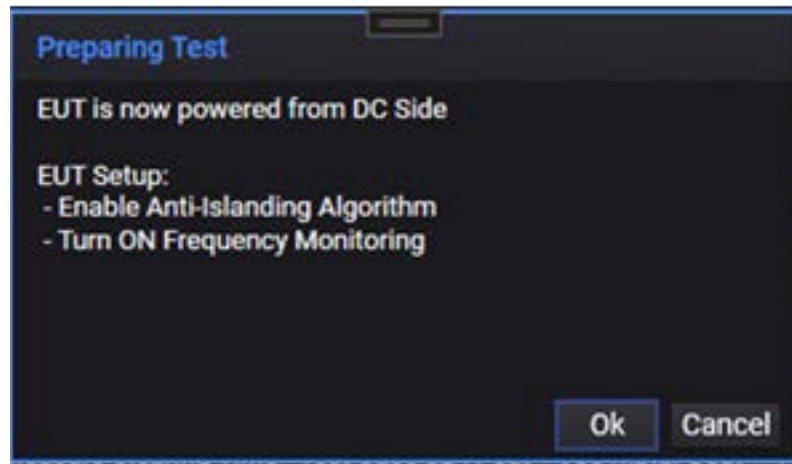

You will also be asked to configure the Power Inverter for the specified test case when in Manual EUT Mode (from the EUT profile).

When the Measure Clearing Time Test Step is running, the **Test Step Status** panel shows the settings, measurements, and progress for each test iteration. Default is running iterations 95-105%. Note that the Parent Step holds this default List of Percentages for all Clearing Time Steps. Also note that the sequence of the percentages follows an alternating pattern, so you can see each side of the clearing time response being exercised during the test. This alternating on either side of 100% can allow you to abort the test quicker if you see one side or the other misbehaving.

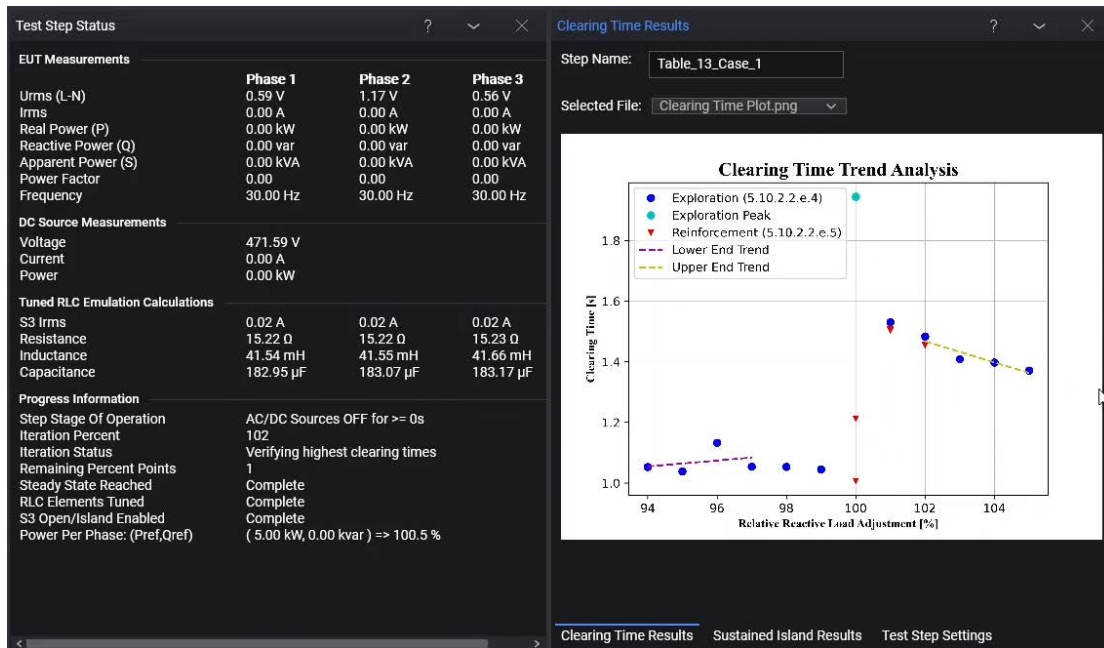

As another example, here are the results of the 95-105% iterations:

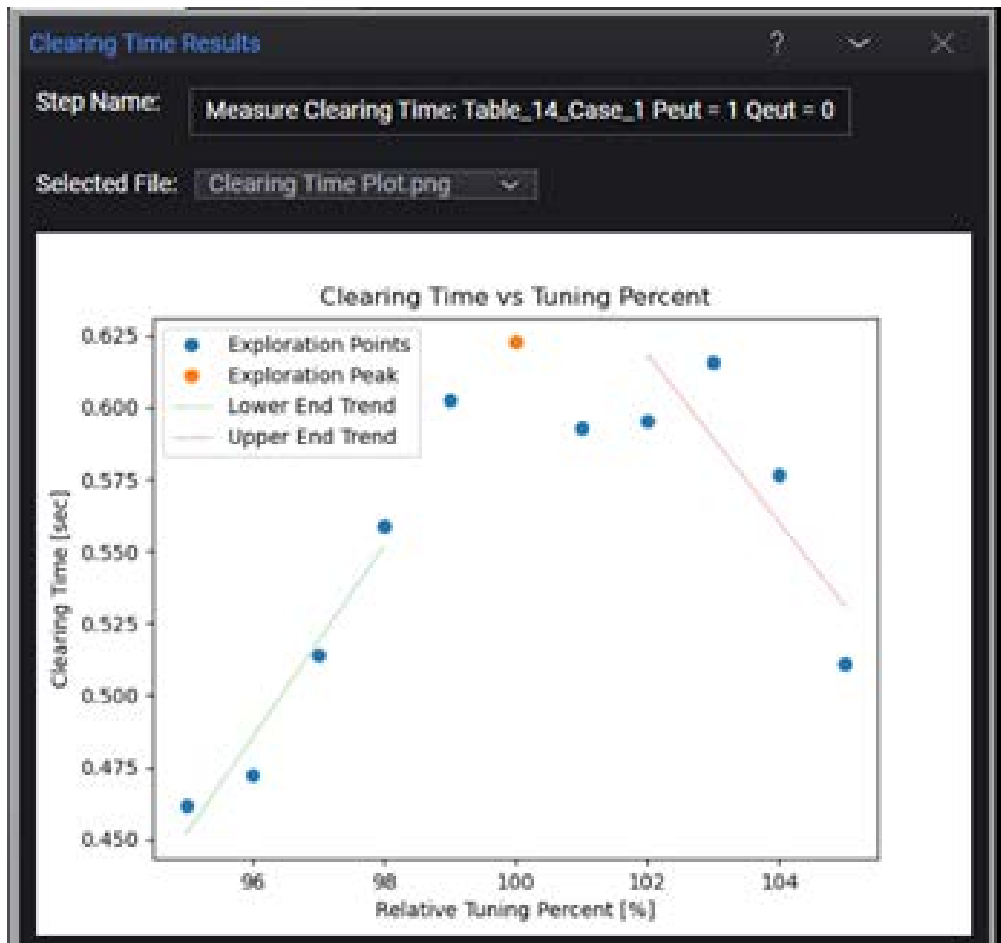

You can also use ranges. For example, if you had entered: 90:94,106:110, the following response occurs. Those 10 points will be tested and added to the Exploration points. The Verification Points are established by making two more Clearing Time measurements of the highest three Exploration Points including any points in between. In the image below, the three highest Exploration Points include points 101 and 102 since they are in between the highest points of 99,100, and 103. The IEEE 1547.1-2020 Standard specifies all the points from 99 to 103 be measured two more times.

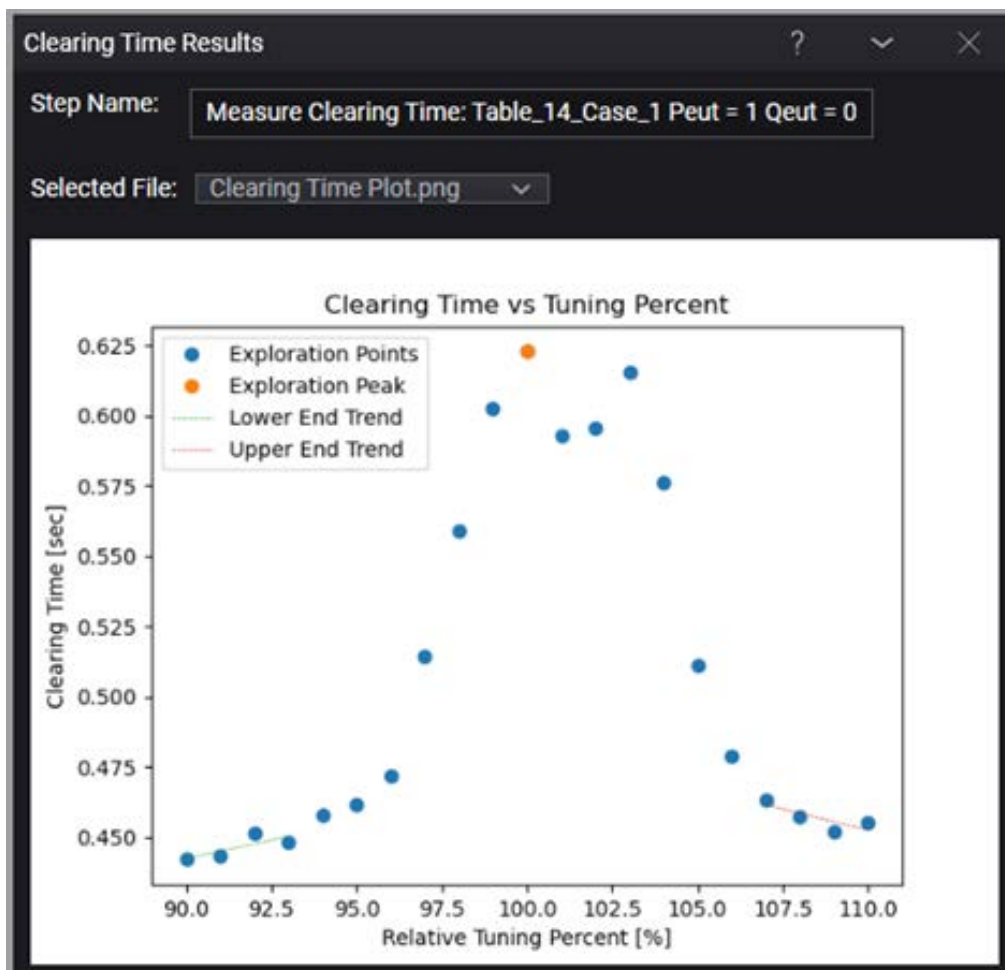

## Measurements and Post Processing Directories

All the measurements and post processed results can be found at the following locations for either Clearing Time or Sustained Island Steps:

Local Disk (C:) > TEMP > My_Power_Inverter_Results > IEEE 1547.1-2020 > 5.10.2			
Name	Date modified	Type	
Clearing_Times	3/7/2025 12:38 PM	File folder	
logs	3/4/2025 4:27 PM	File folder	
Metadata	3/4/2025 3:45 PM	File folder	
Sustained_Islands	3/7/2025 12:38 PM	File folder	

Walking down the directory hierarchy into the Clearing Time Test, we find Test Case 1:

TEMP > My_Power_Inverter_Results > IEEE 1547.1-2020 > 5.10.2 > Clearing_Times > Table_13_Case_1_2025.03.04.12.00.PM				
Name	Date modified	Type	Size	
Analysis Panel	3/7/2025 12:38 PM	File folder		
logs	3/4/2025 12:01 PM	File folder		
Measurements	3/7/2025 12:38 PM	File folder		
Metadata	3/7/2025 12:38 PM	File folder		
Post Processed Results	3/7/2025 12:38 PM	File folder		

Notice that this directory is time stamped, so that each time you run this Measure Clearing Time Step, you do not interfere with any of the previous measurements.

## CSV Measurement Files

The Measurements directory contains the measurements from all the percentage iterations. The files with just “log” contain the 20 kSa/s measurements of Voltage and Current. The “Systemlog” files contain the 1kSa/s RMS, Frequency, and Marker measurements. The following is just a short list of this directory, where test percentages were from 95 - 105%. Each percentage creates a file name based upon that percent. During the Reinforcement or Verification period where points are repeated, plus signs (+) are added for each repeated test point.

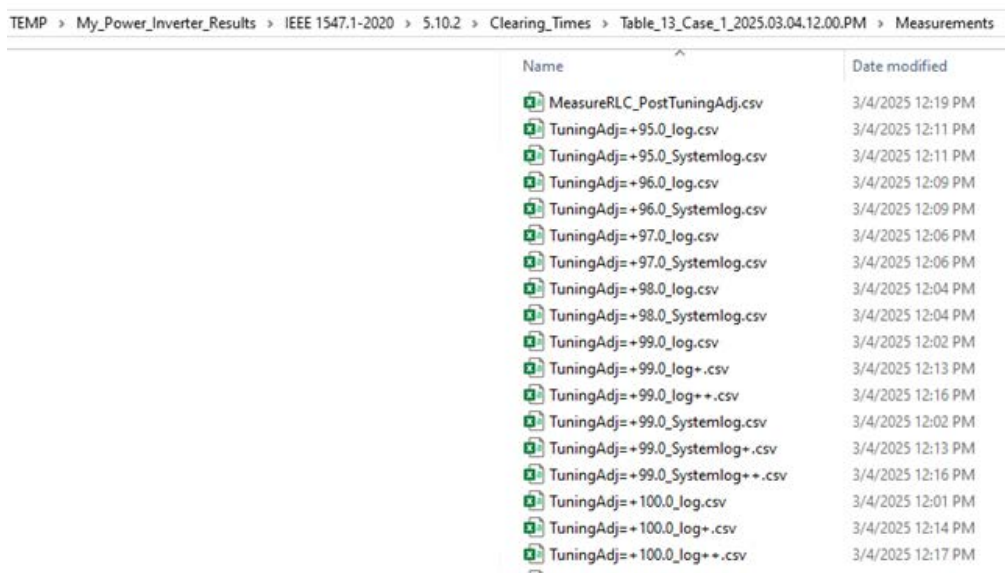

TEMP > My\_Power\_Inverter\_Results > IEEE 1547.1-2020 > 5.10.2 > Clearing\_Times > Table\_13\_Case\_1\_2025.03.04.12.00.PM > Measurements

Name	Date modified
MeasureRLC_PostTuningAdj.csv	3/4/2025 12:19 PM
TuningAdj=+95.0_log.csv	3/4/2025 12:11 PM
TuningAdj=+95.0_Systemlog.csv	3/4/2025 12:11 PM
TuningAdj=+96.0_log.csv	3/4/2025 12:09 PM
TuningAdj=+96.0_Systemlog.csv	3/4/2025 12:09 PM
TuningAdj=+97.0_log.csv	3/4/2025 12:06 PM
TuningAdj=+97.0_Systemlog.csv	3/4/2025 12:06 PM
TuningAdj=+98.0_log.csv	3/4/2025 12:04 PM
TuningAdj=+98.0_Systemlog.csv	3/4/2025 12:04 PM
TuningAdj=+99.0_log.csv	3/4/2025 12:02 PM
TuningAdj=+99.0_log+.csv	3/4/2025 12:13 PM
TuningAdj=+99.0_log++.csv	3/4/2025 12:16 PM
TuningAdj=+99.0_Systemlog.csv	3/4/2025 12:02 PM
TuningAdj=+99.0_Systemlog+.csv	3/4/2025 12:13 PM
TuningAdj=+99.0_Systemlog++.csv	3/4/2025 12:16 PM
TuningAdj=+100.0_log.csv	3/4/2025 12:01 PM
TuningAdj=+100.0_log+.csv	3/4/2025 12:14 PM
TuningAdj=+100.0_log++.csv	3/4/2025 12:17 PM

The Post Processed Results / Processed Runs directory would have all the results of the Exploration percentages and the final analysis .csv files showing the performance of the EUT for this test case..

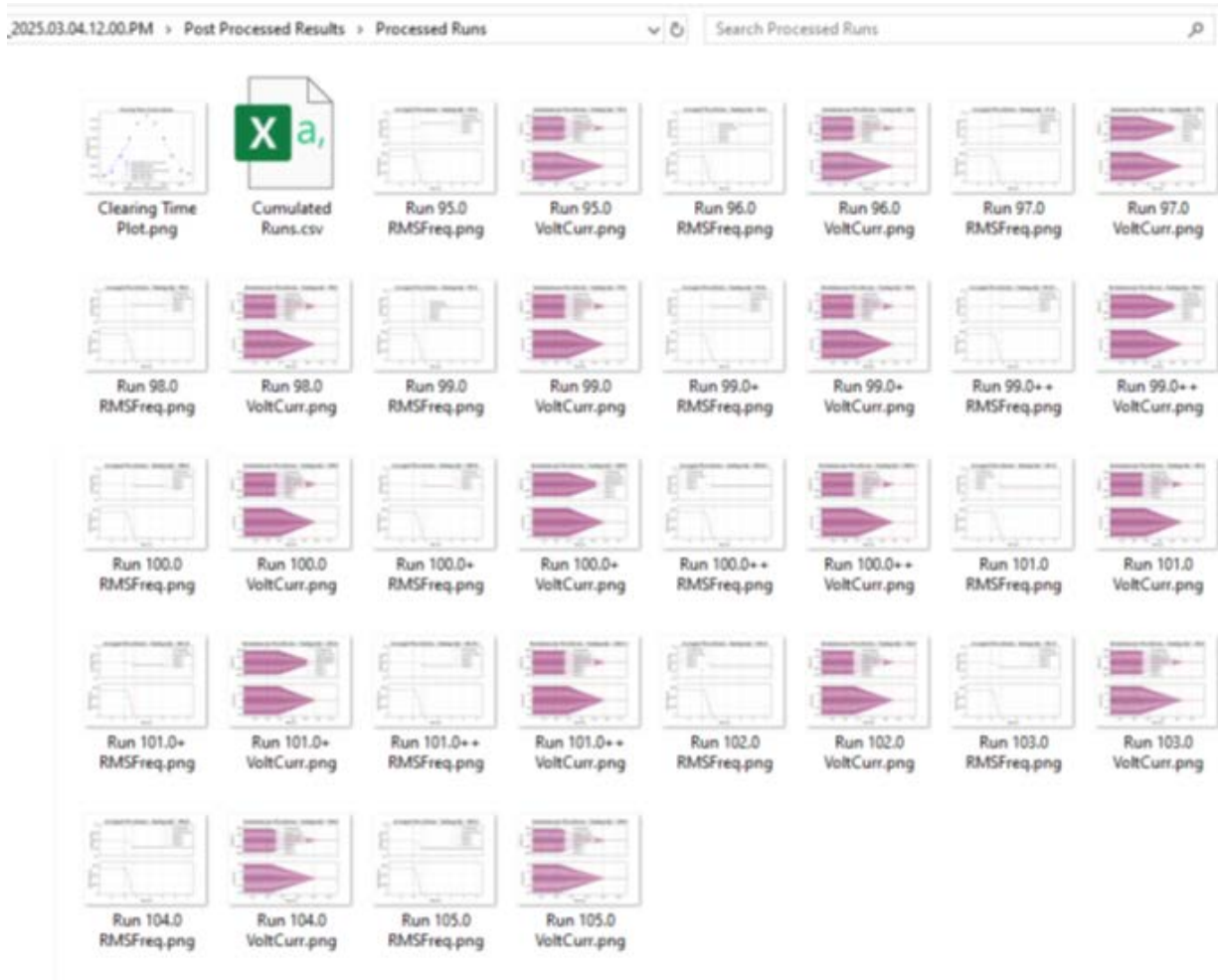

## PNG Waveform Files

Most of the PNG files found in the Processed Runs directory show waveforms created from the Measurements directory files, where the log and Systemlog contain the 20 kSa/s and 1 kSa/s measurements, respectively. Here is an example of the Clearing Time response at 95% change to the Capacitor:

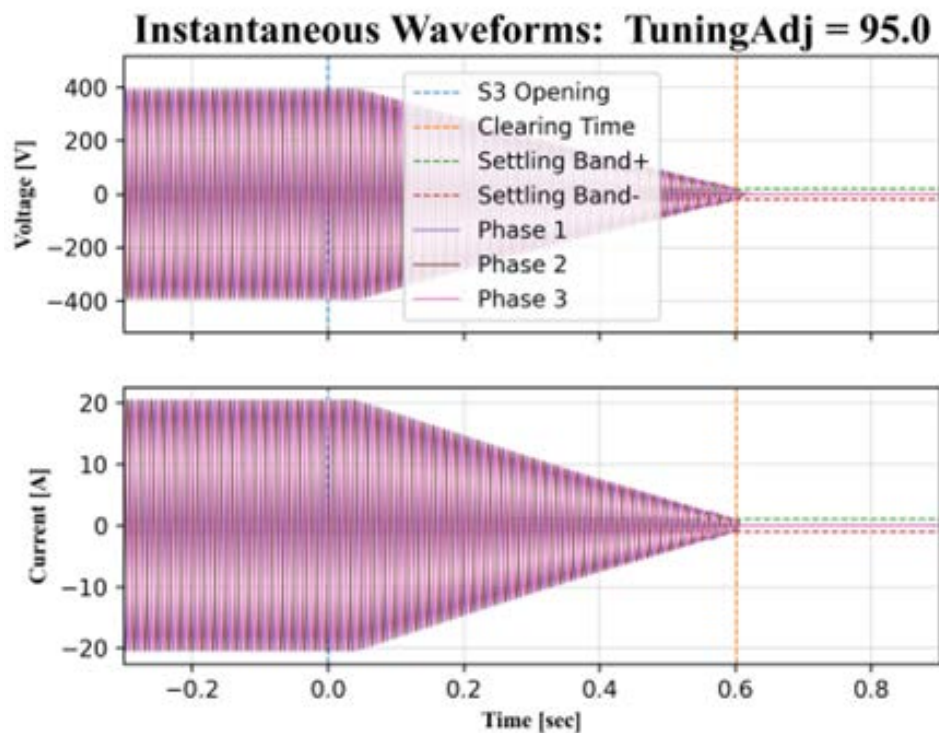

This is the 20 kSa/s data. There is always 200 ms of measurements prior to the Island Event. The time from that event to where the voltage is below the expected threshold is the Clearing Time.

All PNG files are viewable from the Clearing Time and Sustained Island panels in the TAP Editor using a drop-down selection menu.

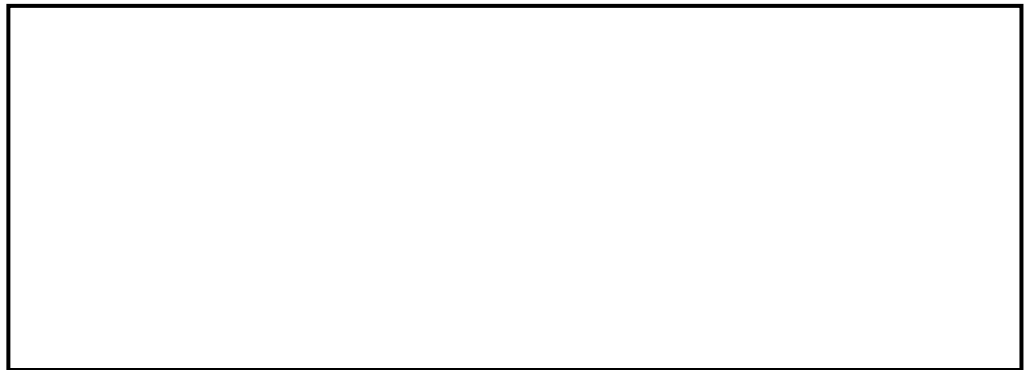

# A Additional TAP Functions

In this Appendix:

- Color Theme [page 87](#)
- Locking a Test Plan [page 88](#)
- Unlocking a Test Plan [page 89](#)
- Run Time Estimation [page 90](#)
- Overview [page 90](#)
- Usage [page 90](#)
- Run Your Test Plan. [page 92](#)
- Additional Notes [page 93](#)
- Run Explorer [page 93](#)
- Editor Settings [page 94](#)
- Test Plan Estimation Capturing [page 94](#)

## Color Theme

Select a color theme for the Test Editor by selecting **Settings > Editor**. Then select either *Light*, *Dark*, or *Automatic* (default). Almost all of the screen captures in this manual use the *Light* theme.

Color Theme (Light) – *Light* is black text on white background. *Dark* is white text on black background.

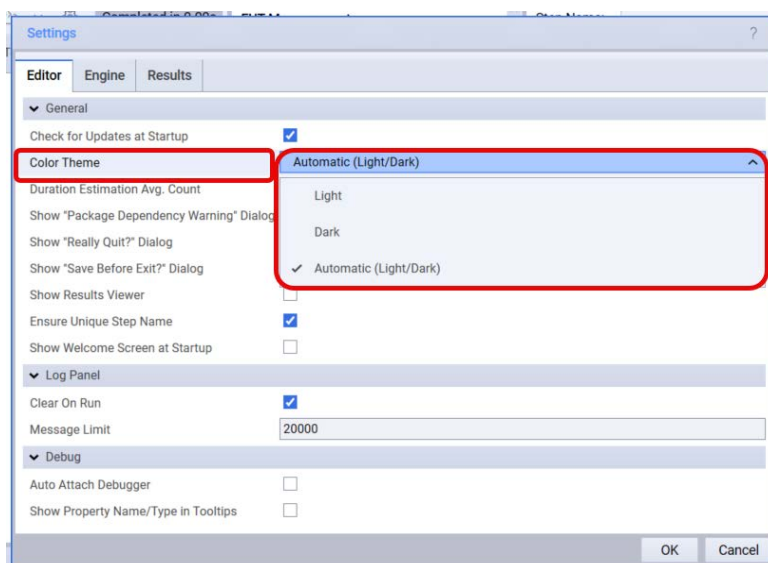

## Locking a Test Plan

Keysight's KS8400 provides a Test plan locking mechanism. Its primary use is to prevent accidental editing by test plan developers. This lock can easily be bypassed by clicking **Unlock Test Plan**.

There are two ways to lock a test plan:

- **First Method:** in the Menu bar, select **File > Lock Test Plan**.

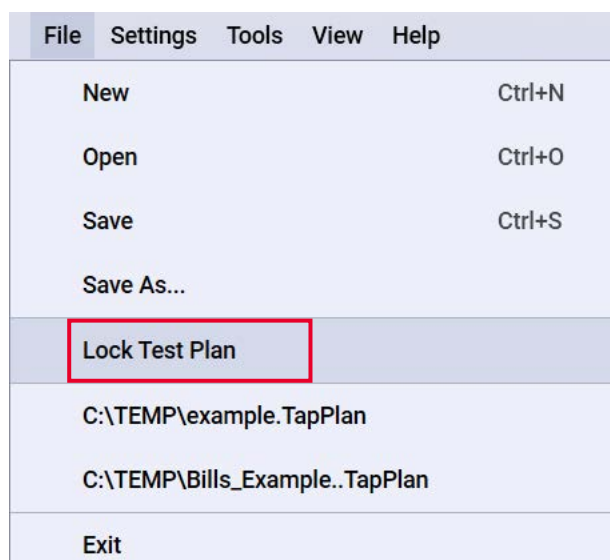

- **Second Method:** In the Menu bar, select **View > Panels > Test Plan Settings**. In this panel, there is a checkbox to Lock/Unlock the test plan labeled **Locked**.

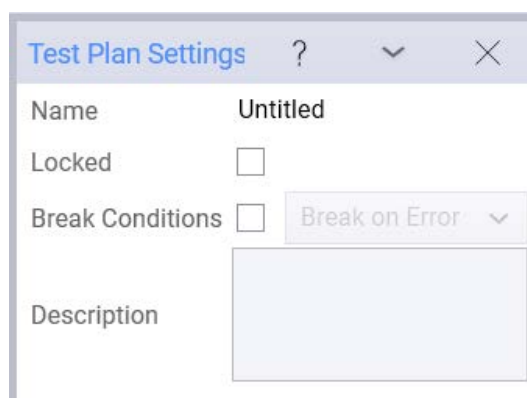

Alternatively, you can reach this panel by clicking the settings icon  that is located next to the main test plan progress bar. This icon also provides a keyboard shortcut (**Alt + E**) to reach this same Test Plan Settings panel.

A locked Test Plan shows a closed lock next to the Test Plan name:



## Unlocking a Test Plan

To unlock the Test plan, either select **File > Unlock Test Plan** or select the settings icon and uncheck the **Locked** checkbox.,

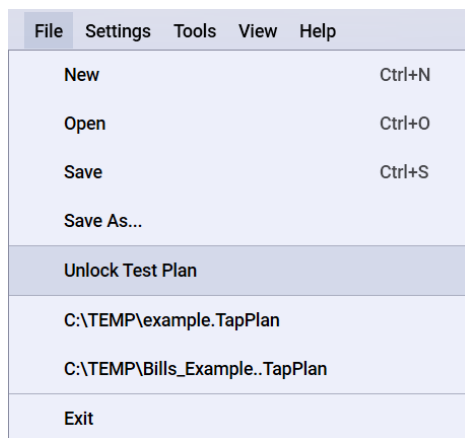

## Run Time Estimation

Keysight's KS8400B Developer's GUI (the Editor) has built-in functionality to estimate Test Plan running time.

### Overview

To access this functionality, add a Result Listener to your configuration that implements `IResultStore` (interface that defines result listener plugins with the capability of storing result data). There are currently two result listener plugins that implement this: *SQLite* and *PostgreSQL*. *PostgreSQL* requires having the database type preconfigured to establish a connection; *SQLite* works without preconfiguration. The following example uses the *SQLite* result listener plugin.

### Usage

- 1 To add the *SQLite* and *PostgreSQL* Database Result Listener plugins, go to **Tools > Package Manager** and install this plugin.

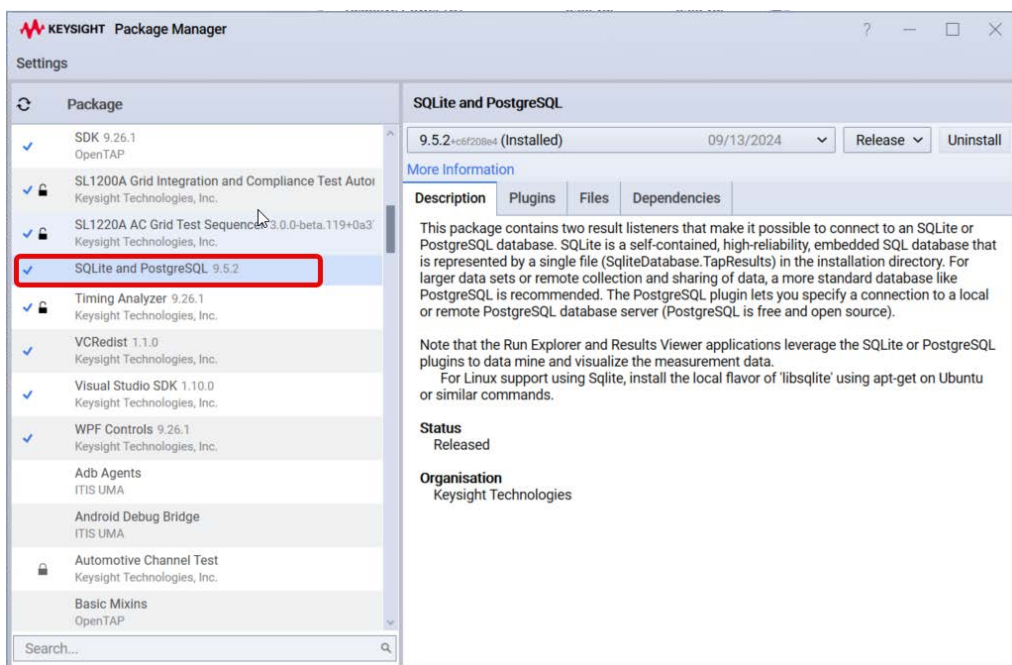

2 Add an SQLite Result Listener plugin to your configuration. This can be done in one of two ways:

a On the Menu bar on the top of the GUI, select **Settings > Results**.

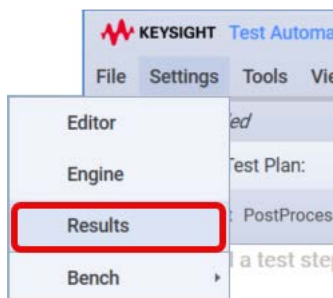

b On the Resource Bar at the bottom of the GUI, click on **Results Add New**.

3 In the Settings window, within the Results tab, click the **+** icon to add a new Result Listener. Go to **Database > SQLite** and click **Add**.



4 Click **OK** in the Settings window to save your changes and add SQLite as a Result Listener.

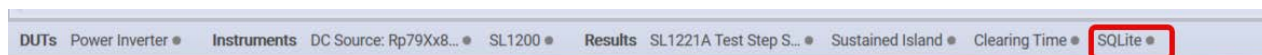

## Run Your Test Plan.

On the first test run, there is no predicted test time. The second test run, and any following test runs of that same test plan, show an estimation of test run duration. This shows up as a tooltip when you hover your mouse over the progress bar above the Test Plan. The progress bar also adds an additional comment about running x% faster/slower than the average.

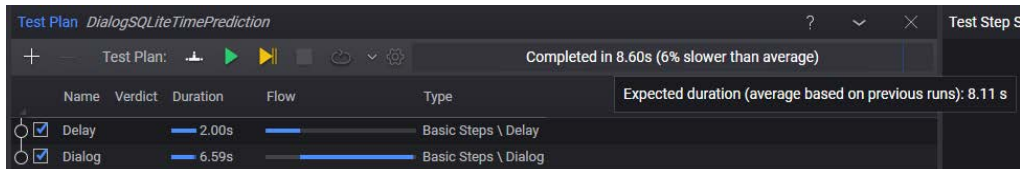

Additionally, individual test steps also provide a tooltip showing the expected duration for that test step.

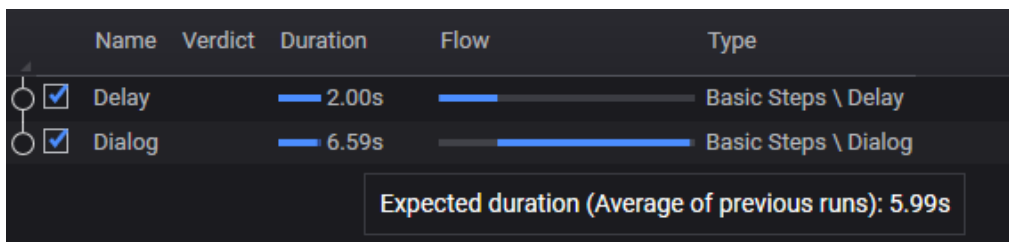

During the test plan run, the progress bar changes to show remaining time after the first run and shows the amount of time over the expected test duration.

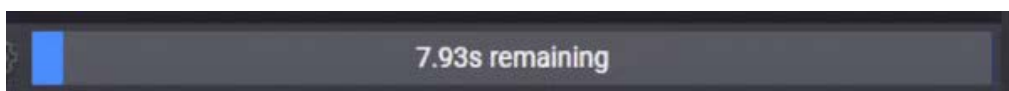

## Additional Notes

### Run Explorer

The SQLite database result listener stores TAP metadata related to the test run. View this data in KS8400B's Run Explorer. To view this, you can go to **Tools > Run Explorer** in the Menu bar.

This view shows every test run stored within this *SQLite* database. Add additional column headers to view by right clicking the header bar and adding a new item. The image below shows the Duration column to get a quick view of the test times of all the Test Plan runs the *SQLite* database stored. The run data persists outside of the current session, so reopening the editor and running the same saved test plan will still give an test time estimation. Use the Run Explorer to delete test runs that are considered outliers in test time.

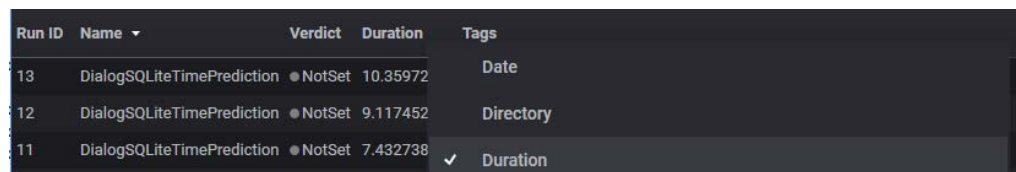
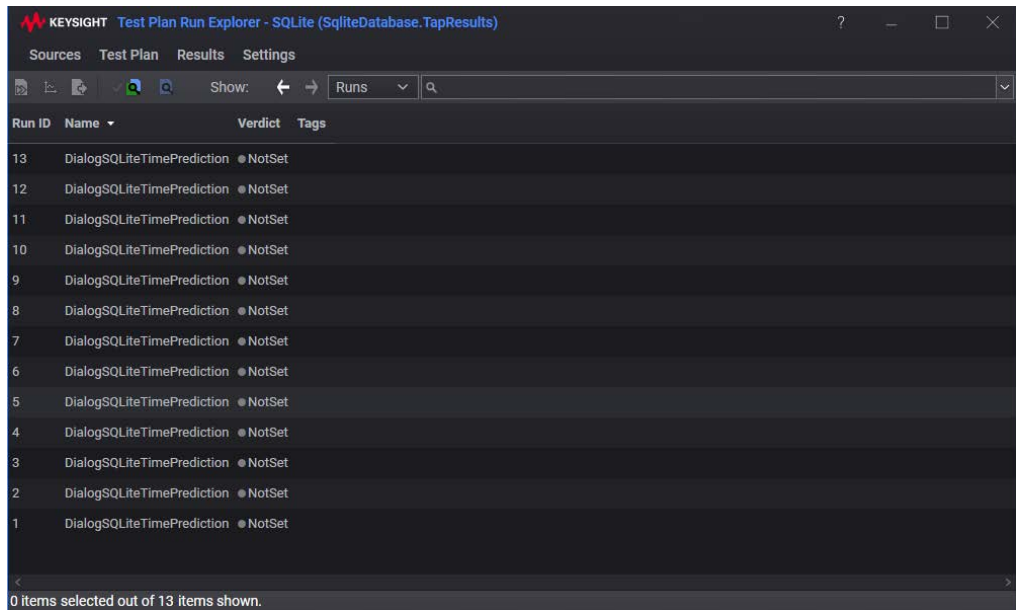

## Editor Settings

You can control how many test runs are used to calculate the average test run time. This is configurable in **Settings > Editor** under **Duration Estimation Avg. Count**. The default value for this setting is the last 10 runs.

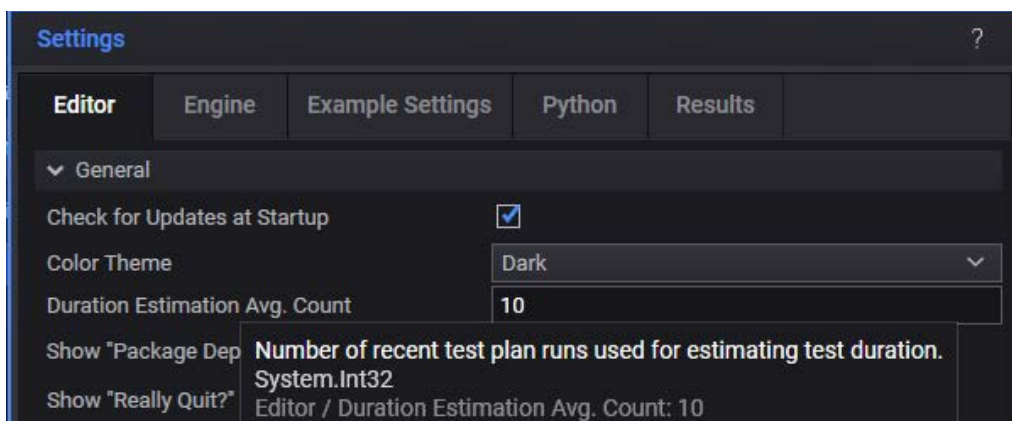

## Test Plan Estimation Capturing

The Editor calculates test run time averages for test plans that are exactly the same. If you change a test step setting value in the test plan and run the updated plan, it counts as the first run of that test plan, therefore not calculating an average test duration (on its first run). Reverting the test plan back to its original state causes the estimation to use its previous duration values again.

# Index

## B

Bench Settings, [12](#), [16](#), [24](#), [25](#)

## C

Child Test Step, [12](#)

Color Theme, [77](#)

## D

Dark, [77](#)

Dependencies tab, [22](#)

Description tab, [22](#)

## E

Estimate Run Time, [80](#)

## F

Files tab, [22](#)

## L

License, [11](#)

Light, [77](#)

Locking a Test Plan, [78](#)

Log Panel, [12](#)

## P

Package, [12](#), [21](#), [22](#)

Package Manager, [12](#), [21](#), [22](#)

Plug-in, [12](#)

Plug-ins tab, [22](#)

## R

Resource Bar, [12](#)

Resources, [12](#)

Results Viewer, [12](#), [26](#)

Run Explorer, [12](#), [26](#)

Run Time Estimation, [80](#)

## S

Saving Test Plans, [34](#)

System prerequisites, [48](#)

## T

Test Plan, [12](#)

    Locking, [78](#)

    Saving, [34](#)

Test Step, [12](#)

Test Step Settings, [12](#)

Time, Run Time Estimation, [80](#)

Timing Analyzer, [12](#), [32](#)

## U

Unlock Test Plan, [78](#)

Unlocking a Test Plan, [79](#)

## Index

### B

Bench Settings, 9, 15, 23, 24

### C

Child Test Step, 9

Color Theme, 87

### D

Dark, 87

Dependencies tab, 21

Description tab, 21

### E

Estimate Run Time, 90

### F

Files tab, 21

### L

License, 8

Light, 87

Locking a Test Plan, 88

Log Panel, 9

### P

Package, 9, 20, 21

Package Manager, 9, 20, 21

Plug-in, 9

Plug-ins tab, 21

### R

Resource Bar, 9

Resources, 9

Results Viewer, 9, 25

Run Explorer, 9, 25

Run Time Estimation, 90

### S

Saving Test Plans, 33

System prerequisites, 57

### T

Test Plan, 9

  Locking, 88

  Saving, 33

Test Step, 9

Test Step Settings, 9

Time, Run Time Estimation, 90

Timing Analyzer, 9, 31

### U

Unlock Test Plan, 88

Unlocking a Test Plan, 89





This information is subject to change without notice.  
© Keysight Technologies, 2024, 2025  
Second Edition, September 2025

[www.keysight.com](http://www.keysight.com)