

Keysight M8132A 640 GSa/s Digital Signal Processor

User's Guide

Notices

© Keysight Technologies 2021

No part of this manual may be reproduced in any form or by any means (including electronic storage and retrieval or translation into a foreign language) without prior agreement and written consent from Keysight Technologies as governed by United States and international copyright laws.

Trademarks

PCI Express® and PCIe® are registered trademarks of PCI-SIG.

Manual Part Number

M8132-91010

Edition

Edition 2.4, November 2021

Keysight Technologies Deutschland GmbH
Herrenberger Strasse 130,
71034 Böblingen, Germany

Technology Licenses

The hardware and/or software described in this document are furnished under a license and may be used or copied only in accordance with the terms of such license.

U.S. Government Rights

The Software is “commercial computer software,” as defined by Federal Acquisition Regulation (“FAR”) 2.101. Pursuant to FAR 12.212 and 27.405-3 and Department of Defense FAR Supplement

(“DFARS”) 227.7202, the U.S. government acquires commercial computer software under the same terms by which the software is customarily provided to the public. Accordingly, Keysight provides the Software to U.S. government customers under its standard commercial license, which is embodied in its End User License

Agreement (EULA), a copy of which can be found at <http://www.keysight.com/find/sweula>. The license set forth in the EULA represents the exclusive authority by which the U.S. government may use, modify, distribute, or disclose the Software. The EULA and the license set forth therein, does not require or permit, among other things, that Keysight: (1) Furnish technical information related to commercial computer software or commercial computer software documentation that is not customarily provided to the public; or (2) Relinquish to, or otherwise provide, the government rights in excess of these rights customarily provided to the public to use, modify, reproduce, release, perform, display, or disclose commercial computer software or commercial computer software documentation. No additional government requirements beyond those set forth in the EULA shall apply, except to the extent that those terms, rights, or licenses are explicitly required from all providers of commercial computer software pursuant to the FAR and the DFARS and are set forth specifically in writing elsewhere in the EULA. Keysight shall be under no obligation to update, revise or otherwise modify the Software. With respect to any technical data as defined by FAR 2.101, pursuant to FAR 12.211 and 27.404.2 and DFARS 227.7102, the U.S. government acquires no greater than Limited Rights as defined in FAR 27.401 or DFAR 227.7103-5 (c), as applicable in any technical data.

Warranty

THE MATERIAL CONTAINED IN THIS DOCUMENT IS PROVIDED "AS IS," AND IS SUBJECT TO BEING CHANGED, WITHOUT NOTICE, IN FUTURE EDITIONS. FURTHER, TO THE MAXIMUM EXTENT PERMITTED BY APPLICABLE LAW, KEYSIGHT DISCLAIMS ALL WARRANTIES, EITHER EXPRESS OR IMPLIED WITH REGARD TO THIS MANUAL

AND ANY INFORMATION CONTAINED HEREIN, INCLUDING BUT NOT LIMITED TO THE IMPLIED WARRANTIES OF MERCHANTABILITY AND FITNESS FOR A PARTICULAR PURPOSE. KEYSIGHT SHALL NOT BE LIABLE FOR ERRORS OR FOR INCIDENTAL OR CONSEQUENTIAL DAMAGES IN CONNECTION WITH THE FURNISHING, USE, OR PERFORMANCE OF THIS DOCUMENT OR ANY INFORMATION CONTAINED HEREIN. SHOULD KEYSIGHT AND THE USER HAVE A SEPARATE WRITTEN AGREEMENT WITH WARRANTY TERMS COVERING THE MATERIAL IN THIS DOCUMENT THAT CONFLICT WITH THESE TERMS, THE WARRANTY TERMS IN THE SEPARATE AGREEMENT WILL CONTROL.

Safety Notices

CAUTION

A CAUTION notice denotes a hazard. It calls attention to an operating procedure, practice, or the like that, if not correctly performed or adhered to, could result in damage to the product or loss of important data. Do not proceed beyond a CAUTION notice until the indicated conditions are fully understood and met.

WARNING

A WARNING notice denotes a hazard. It calls attention to an operating procedure, practice, or the like that, if not correctly performed or adhered to, could result in personal injury or death. Do not proceed beyond a WARNING notice until the indicated conditions are fully understood and met.

Safety Summary

The following general safety precautions must be observed during all phases of operation of this instrument. Failure to comply with these precautions or with specific warnings or operating instructions in the product manuals violates safety standards of design, manufacture, and intended use of the instrument. Keysight Technologies assumes no liability for the customer's failure to comply with these requirements. Product manuals are provided with your instrument on CD-ROM and/or in printed form. Printed manuals are an option for many products. Manuals may also be available on the Web. Go to www.keysight.com and type in your product number in the Search field at the top of the page. Safe operation and the general safety precautions for the M9502A and M9505A AXle chassis, must be followed. See: <http://www.keysight.com/find/M9505A>.

Initial Inspection

Inspect the shipping container for damage. If there is damage to the container or cushioning, keep them until you have checked the contents of the shipment for completeness and verified the instrument both mechanically and electrically. The Performance Tests give procedures for checking the operation of the instrument. If the contents are incomplete, mechanical damage or defect is apparent, or if an instrument does not pass the operator's checks, notify the nearest Keysight Technologies Sales/Service Office.

WARNING To avoid hazardous electrical shock, do not perform electrical tests when there are signs of shipping damage to any portion of the outer enclosure (covers, panels, etc.).

General

This product is a Safety Class 3 instrument (provided with a protective earth terminal). The protective features of this product may be impaired if it is used in a manner not specified in the operation instructions.

Laser Safety Information

Class 1 Laser product according IEC60825-1 (2007).

Environment Conditions

This instrument is intended for indoor use in an installation category II, pollution degree 2 environment. It is designed to operate within a temperature range of 0 °C – 40 °C (32 °F – 105 °F) at a maximum relative humidity of 80% and at altitudes of up to 2000 meters.

This module can be stored or shipped at temperatures between -40 °C and +70 °C. Protect the module from temperature extremes that may cause condensation within it.

Before Applying Power

Verify that all safety precautions are taken. The power cable inlet of the instrument serves as a device to disconnect from the mains in case of hazard. The instrument must be positioned so that the operator can easily access the power cable inlet. When the instrument is rack mounted the rack must be provided with an easily accessible mains switch.

Line Power Requirements

The Keysight M8132A operates when installed in an Keysight AXle mainframe.

Do Not Operate in an Explosive Atmosphere

Do not operate the instrument in the presence of flammable gases or fumes.

Do Not Remove the Instrument Cover

Operating personnel must not remove instrument covers. Component replacement and internal adjustments must be made only by qualified personnel.

Instruments that appear damaged or defective should be made inoperative and secured against unintended operation until they can be repaired by qualified service personnel.

Ground the Instrument



To minimize shock hazard, the instrument chassis and cover must be connected to an electrical protective earth ground. The instrument must be connected to the ac power mains through a grounded power cable, with the ground wire firmly connected to an electrical ground (safety ground) at the power outlet. Any interruption of the protective (grounding) conductor or disconnection of the protective earth terminal will cause a potential shock hazard that could result in personal injury.

Instrument Markings

The **Table 1** lists the definitions of markings that may be on or with the product.



Table 1 Instrument Markings

Marking	Description
	The instruction documentation symbol. The product is marked with this symbol when it is necessary for the user to refer to the instruction in the documentation.
	Frame or chassis ground terminal. Typically connects to the equipment's metal frame.
	KC is the Korean certification mark to demonstrate that the equipment is Class A suitable for professional use and is for use in electromagnetic environments outside of the home.
	Indicates that anti-static precautions should be taken.
	China Restricted Substance Product Label. The EPUP (environmental protection use period) number in the center indicates the time period during which no hazardous or toxic substances or elements are expected to leak or deteriorate during normal use and generally reflects the expected useful life of the product.
	The RCM mark is a registered trademark of the Australian Communications and Media Authority.
	The CSA mark is a registered trademark of the CSA International.

Marking	Description
	The CE mark is a registered trademark of the European Community (if accompanied by a year, it is the year when the design was proven). This product complies with all relevant directives.
	Universal recycling symbol. This symbol indicates compliance with the China standard GB 18455-2001 as required by the China RoHS regulations for paper/fiberboard packaging.
	The Keysight email address is required by EU directives applicable to our product.

Compliance and Environmental Information

Table 2 Compliance and Environmental Information

Safety Symbol	Description
 	<p>This product complies with WEEE Directive (2002/96/EC) marking requirements. The affixed label indicates that you must not discard this electrical/electronic product in domestic household waste.</p> <p>Product Category: With reference to the equipment types in WEEE Directive Annex I, this product is classed as a “Monitoring and Control instrumentation” product.</p> <p>Do not dispose in domestic household waste.</p> <p>To return unwanted products, contact your local Keysight office, or see http://about.keysight.com/en/companyinfo/environment/takeback.shtml for more information.</p>

Contents

Safety Summary	3
Instrument Markings	5
Compliance and Environmental Information	7

1 Introduction

M8132A Overview	17
Key Features	17
Instrument Options	18
Front Panel	18
Related Documents	20
Additional Documents	21

2 Software Installation

3 Soft Front Panel

Launching the Soft Front Panel	26
Command Line Arguments	29
Communication	30
Soft Front Panel	32
Title Bar	33
Menu Bar	33
Lower Pane	35
Errors List Window	36
Status Bar	37
Clock Tab	38
IOs Tab	39

IOs Tab in 10GbE mode	42
Cabling for 10GbE Connectivity	50

System Monitor Tab	51
---------------------------	----

4 Control In/Out

Control In/Out and Trigger Input	54
Input Multiplexer of the Switch Matrix	55
Output Multiplexer of the Switch Matrix	56
Trigger Input	57

5 Using KF 9000B PathWave FPGA with the M8132A

6 Remote Programming

Remote Programming Overview	62
Instructions	62
Instruction Header	62
White Space (Separator)	62
Braces	63
Ellipsis	63
Square Brackets	63
Program Data	63
Status Commands	64
STATus:PRESet	66
Status Byte Register	66
Questionable Data Register Command Subsystem	67
Reference Clock Status Subsystem	68
Connection Status Subsystem	68
Latency Calibration Commands	70
:CALibrate:LATency:LCMPeriod	70
:CALibrate:LATency:MODE	70
:CALibrate:LATency[:STEP]	71
:CALibrate:LATency:SPDelay	71

Common Commands 72

*IDN?	72
*CLS	72
*ESE	72
ESR?	72
*OPC	72
*OPC?	73
*OPT?	73
*RST	73
*SRE[?]	73
*STB?	73
*TST?	73
*LRN?	74
*WAI?	74

System Commands 75

:SYSTem:ERRor[:NEXT]?	75
:SYSTem:HELP:HEADers?	75
:SYSTem:LICense:EXTended:LIST?	76
:SYSTem:SET[?]	76
:SYSTem:VERSion?	77
:SYSTem:COMMunicate:*?	77
:SYSTem:COMMunicate:INSTr[:NUMBer]?	77
:SYSTem:COMMunicate:HISLip[:NUMBer]?	78
:SYSTem:COMMunicate:SOCKet[:PORT]?	78
:SYSTem:COMMunicate:TELNet[:PORT]?	78
:SYSTem:COMMunicate:TCPIP:CONTRol?	78
:SYSTem:ERRor:COUNt?	79
:SYSTem:LICense:LIST?	79
:SYSTem:LICense:SUBScription:DATE?	79

Time Base Commands 80

:TIMebase:REFClock	80
--------------------	----

Instrument Commands	81
:INSTRument:SLOT[:NUMBer]?	81
:INSTRument:IDENTify	81
:INSTRument:IDENTify:STOP	81
:INSTRument:HWRevision?	81
FPGA Access Commands	82
:INSTRument:FPGA:UPDate	82
:INSTRument:FPGA:RESet	82
:INSTRument:FPGA:DIRect:DWORd[?]	83
:INSTRument:FPGA:DIRect:BLOCK[?]	83
:INSTRument:FPGA:GEARbox:CLEar	84
:INSTRument:FPGA:GEARbox:STARt	84
Current and Power Monitor Commands	85
:INSTRument:MONitor:CURRent[:TOTal]?	85
:INSTRument:MONitor:CURRent:MGTAVCC?	85
:INSTRument:MONitor:CURRent:MGTAVTT?	85
:INSTRument:MONitor:CURRent:VCCINT?	86
:INSTRument:MONitor:POWer[:TOTal]?	86
:INSTRument:MONitor:POWer:MGTAVCC?	86
:INSTRument:MONitor:POWer:MGTAVTT?	87
:INSTRument:MONitor:POWer:VCCINT?	87

Sandbox Commands	88
:INSTRument:SANDbox<M>:NAME?	88
:INSTRument:SANDbox<M>:FNAMe?	88
:INSTRument:SANDbox<M>:FVERsion?	88
:INSTRument:SANDbox<M>:KID?	89
:INSTRument:SANDbox<M>:SID?	89
:INSTRument:SANDbox<M>:CONFigure	89
:INSTRument:SANDbox<M>:RLISt?	90
:INSTRument:SANDbox<M>:RINFo?	90
:INSTRument:SANDbox<M>:PEEK?	90
:INSTRument:SANDbox<M>:POKE	91
:INSTRument:SANDbox<M>:SREAd?	91
:INSTRument:SANDbox<M>:SREAd:BLOCK?	91
:INSTRument:SANDbox<M>:SWRite	92
:INSTRument:SANDbox<M>:SWRite:BLOCK	92
:INSTRument:SANDbox<M>:MLISt?	92
:INSTRument:SANDbox<M>:MINFo?	93
:INSTRument:SANDbox<M>:MREAd?	93
:INSTRument:SANDbox<M>:MREAd:BLOCK?	93
:INSTRument:SANDbox<M>:MWRite	94
:INSTRument:SANDbox<M>:MWRite:BLOCK	94

Optical Data Interface Commands	95
:ODI:ACHannels?	95
:ODI:PORT:COUNT?	95
:ODI:PORT<N>:CAPability:DIRection?	96
:ODI:PORT<N>:CAPability:FCONtrols?	96
:ODI:PORT<N>:CAPability:LANes?	96
:ODI:PORT<N>:CAPability:NAME?	97
:ODI:PORT<N>:CAPability:RATes?	97
:ODI:PORT<N>:CAPability:RBMax?	97
:ODI:PORT<N>:CAPability:TBMax?	97
:ODI:PORT<N>:CAPability:TRMatch?	98
:ODI:PORT<N>:NAME?	98
:ODI:PORT<N>:ACTivate	98
:ODI:PORT<N>:DEACTivate	99
:ODI:PORT<N>:CSTATUS?	99
:ODI:PORT<N>:PSTATistics:BBURsts?	101
:ODI:PORT<N>:PSTATistics:RBYTes?	101
:ODI:PORT<N>:PSTATistics:TBYTes?	101
:ODI:PORT<N>:PSTATistics:THOFFs?	101
Trigger Commands	102
:TRIGger:OUTPut:MODE	102
:TRIGger:OUTPut:SOURce	103
:TRIGger:LEVel:EXTernal	103
Control In/Out Commands	104
:CIOut:MUX	104
:CIOut:MUX:CLR	106
:CIOut:OUTPut	106
TEST Commands	107
:TEST:PON?	107
:TEST:TST?	107

Ethernet Commands	108
:ETHernet:PORT[1-8]:[STAtE][?]	108
:ETHernet:PORT[1-8]:FRAMe:MACSource:[STAtE][?]	108
:ETHernet:PORT[1-8]:FRAMe:MACSource:VALue[?]	109
:ETHernet:PORT[1-8]:FRAMe:MACDest:[STAtE][?]	109
:ETHernet:PORT[1-8]:FRAMe:MACDest:VALue [?]	110
:ETHernet:PORT[1-8]:FRAMe:ETHertype:[STAtE][?]	110
:ETHernet:PORT[1-8]:FRAMe:ETHertype:VALue[?]	111
:ETHernet:PORT[1-8]:CStatus?	111
:ETHernet:PORT[1-8]:PStAtistics[:RX]:GOOD?	112
:ETHernet:PORT[1-8]:PStAtistics[:RX]:BAD?	112
:ETHernet:PORT[1-8]:PStAtistics[:RX]:DROPped?	112
:ETHernet:PORT[1-8]:PStAtistics[:RX]:BYTes?	113
:ETHernet:PORT[1-8]:PStAtistics:TX:BYTes?	113
:ETHernet:PORT[1-8]:PStAtistics:ALL?	113

7 Examples

Introduction	116
PathwaveCapture	117
Cabling of DSP Connectors	117
Setup DSP	117
Usage	117
PathwaveLoopThrough	118
Cabling of DSP Connectors	118
Usage	118
Optional Parameters	119
PathwaveDpu2Dpu	120
Cabling of DSP Connectors	120
Setup DSP	120
Usage	120

PathwaveEthernet	121
Cabling of DSP Connectors	121
Setup DSP	121
Usage	121

Continuous Streaming with Deterministic Latency to DSP Module	122
--	-----

8 Characteristics

Performance Specification	123
Operating Environment	123
General	124

Index

1 Introduction

[M8132A Overview](#) / 17

[Key Features](#) / 17

[Front Panel](#) / 18

[Related Documents](#) / 20

[Additional Documents](#) / 21

This chapter provides an overview of M8132A 640 GSa/s Digital Signal Processor module.

M8132A Overview

The Keysight M8132A is a 640 GSa/s Digital Signal Processor.

Key Features

The M8132A Digital Signal Processor provides the following key features:

- Two large Xilinx Ultrascale+ VU9P FPGAs usable for custom processing functions
- 4 x 160 Gb/s bidirectional optical data interfaces (ODI) or 3x 160Gbits/s input/output and 8 * 10Gbe Ethernet
- Aggregate throughput 640 Gb/s input + 640 Gb/s output
- PCIe backplane interface up to Gen3 x8
- Part of Keysight's Wideband Solution Platform (WSP)
- Deterministic latency between Digitizer (M8131A), DSP module (M8132A) and AWG (M8121A)
- 2-slot AXIe module

NOTE

Deep technical FPGA design expertise as well as knowledge working with Vivado™ FPGA design flow from Xilinx is required to successfully implement functionality in the M8132A module.

Please contact Keysight prior to purchasing the product to discuss the required configuration as well as support requirements.

Instrument Options

The M8132A can be ordered as M8132A-002. The -002 indicates that two Xilinx Ultrascale+ VU9P FPGAs are available.

Front Panel

Figure 1 on page 18 illustrates the front panel of the M8132A instrument.



Figure 1 M8132A front panel

The M8132A front panel includes the following input/output ports:

Inputs/Outputs

- **ODI** - The four Optical Data Interface ports (ODI 1/2/3/4) can be used for optical data streaming. ODI 4 can be used for 8*10Gbe Ethernet.
- **Trig In** - The Trigger Input can be used for external triggering. As Trigger source e.g. an external pulse generator can be connected. The FPGA designer has access to the “Trigger Input” signal inside both FPGA and may implement desired functionality.

- **Trig Out** - The Trigger Output can be used to trigger external instruments or DUTs. The FPGA designer can control the “Trigger Output” signal inside both FPGA and may implement desired functionality.
- **Sync In** - The Sync Input can be used to synchronize the M8132A DSP module with an M8131A digitizer module in order to achieve a deterministic latency between the M8131A and the M8132A. Sync In of the M8132A is connected to the Sync Out of the M8131A digitizer module.
- **Sync Out** - The four Sync Outputs can be used to synchronize the M8132A with one or more M8121A AWG modules in order to achieve deterministic latency between the M8132A and the M8121A AWG. Sync Out of the M8132A is connected to the Sync In of the M8121A AWG module.
- **Ref Clk In** - The Reference Clock Input can be used to synchronize to an external clock.
- **Ref Clk Out** - The Reference Clock Output can be used to synchronize a DUT to the M8132A.
- **FPGA Config** - The FPGA Configuration connector can be used to debug open FPGA externally.
- **Control In/Out** - The Control Input/Output offers a 10-bit parallel interface. Bit 0 to 4 is configured as input, bit 5 to 9 is configured as output. The Control In/Out is connected with the sandbox ports of the FPGAs.

LEDs

The M8132A front panel include the following LEDs:

- **Status LEDs**

The “Fail” and “Access” LEDs are available at the front panel to indicate the status of the M8132A module:

- The green ‘Access’ LED indicates that the controlling PC exchanges data with the M8132A module.
- The red ‘Fail’ LED has following functionality:
 - It is ‘ON’ for about 30 seconds after powering the AXIe chassis.
 - After about 30 seconds the LED is switched ‘OFF’. If an external PC is used to control the AXIe chassis, this PC can be powered after this LED has switched OFF.
 - During normal operation of the module this LED is ‘OFF’. In case of an error condition such as e.g. a self-test error, the LED is switch ‘ON’.

- In case the output relay has shut-off because of an external overload condition, this LED flashes.
- **Trig In LED** - This LED indicates that an externally applied signal matches the adjusted threshold to be used as a Trigger. The LED turns on for ~100 ms for each detected edge of the correct polarity. I.e. a rising edge turns the LED on for 100 ms if the polarity is adjusted to rising. If the polarity is adjusted to rising and a falling edge is externally applied, the LED remains OFF. The functionality of this LED is for future use and is currently not supported.
- **Ref Clk In LED** - This LED is green when a valid signal at Ref Clk In is detected. In case of invalid signals, it is red. The functionality of this LED is for future use and is currently not supported.

Related Documents

To access documentation related to the Keysight M8132A Digital Signal Processor, use one of the following methods:

- **CD** - Browse the product CD for M8132A documentation.
- **Start > All Programs > Keysight M8131 > Keysight M8131 Documentation** - Provides links to all product documentation except for the IVI driver documentation.
- **Start > All Programs > Keysight Instrument Drivers > KtM8131 Digitizer** - Provides link to the product IVI driver help system.
- Go to the product web site (www.keysight.com/find/M8132A) and browse the manuals under **Document Library** tab.

Additional Documents

Additional documentation can be found at:

- <http://www.keysight.com/find/M9502A> for 2-slot chassis related documentation.
- <http://www.keysight.com/find/M9505A> for 5-slot chassis related documentation.
- <http://www.keysight.com/find/M9506A> for 5-slot chassis related documentation.
- <http://www.keysight.com/find/M9514A> for 14-slot chassis related documentation.
- <http://www.keysight.com/find/M9537A> for embedded AXIe controller related documentation.
- <http://www.keysight.com/products/KF9000B> for KF9000B PathWave FPGA related documentation.

2 Software Installation

The M8132A Digital Signal Processor package is installed along with the M8131A Digitizer package, using the same installer. Therefore, all prerequisites and installation procedure for M8132A module is the same as that for M8131A. For more information, refer to the *M8131A User Guide*.

<http://www.keysight.com/find/M8131A>

3 Soft Front Panel

- Launching the Soft Front Panel / 26
- Command Line Arguments / 29
- Communication / 30
- Soft Front Panel / 32
- Clock Tab / 38
- IOs Tab / 39
- IOs Tab in 10GbE mode / 42
- System Monitor Tab / 51

This chapter describes the M8132A Soft Front Panel.

Launching the Soft Front Panel

There are two ways to launch the M8132A Soft Front Panel:

- 1 Select **Start > All Programs > Keysight M8131 > Keysight M8131 Soft Front Panel** from the **Start** menu.
- 2 From the **Keysight Connection Expert** select the discovered M8132 module, select the **“Installed Software”** tab and press the **“Soft Front Panel”** icon. Please note that only instruments connected via PCIe are shown in the **Keysight Connection Expert**.

The following **Connect to Instrument** dialog will appear:

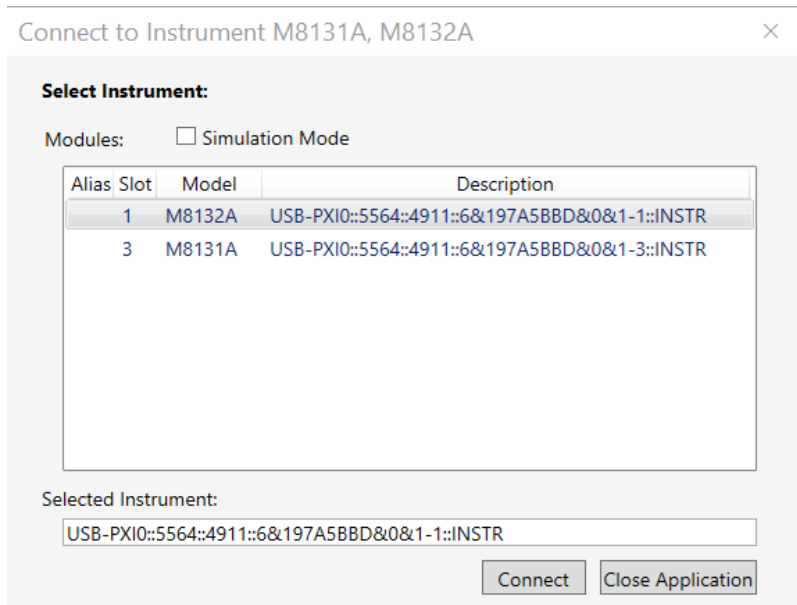

Figure 2 M8132A connected to PC

This dialog shows the addresses of the discovered M8132A modules. Select a module from the list and press “Connect”.

If no M8132A module is connected to your PC, you can select “Simulation Mode” to simulate an M8132A module.

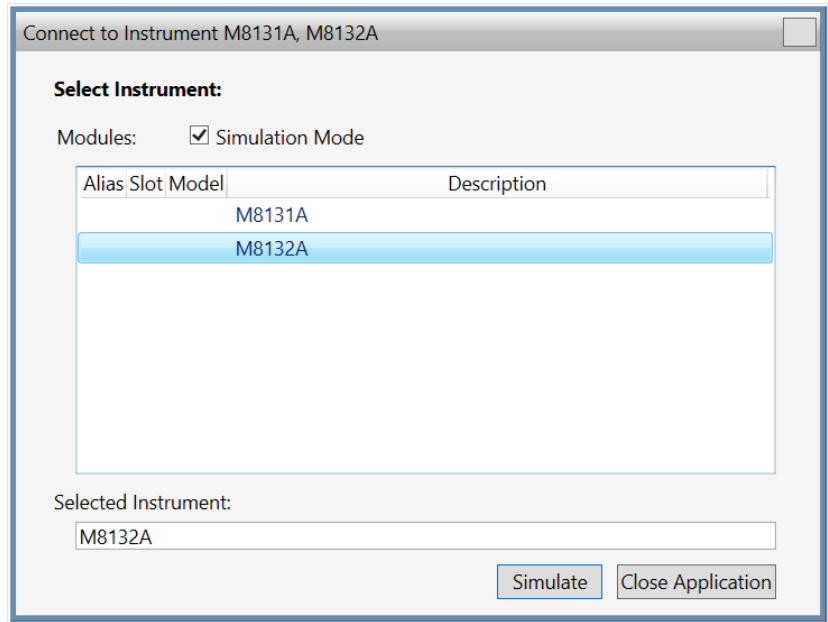

Figure 3 M8132A in simulation mode

Next, a software startup screen will be displayed as shown in [Figure 4](#) on page 28.

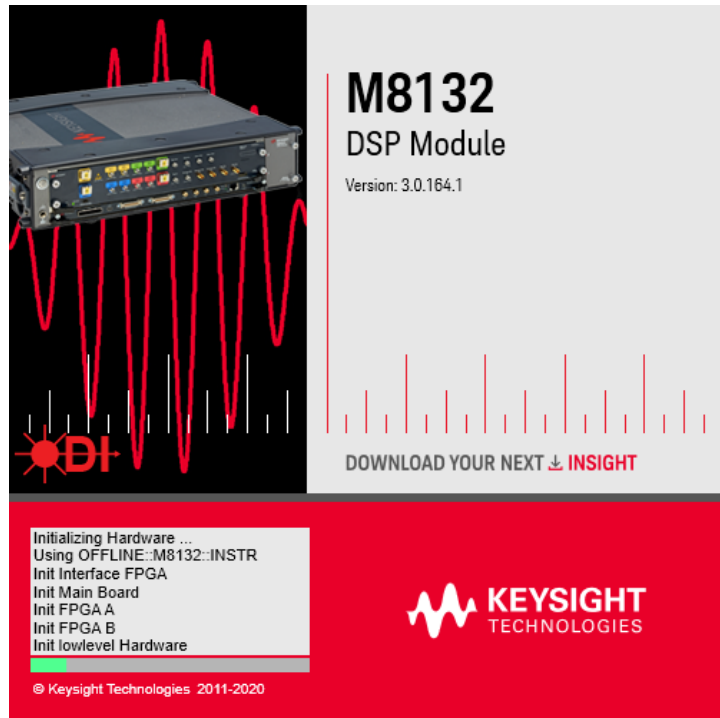

Figure 4 M8132A startup screen

Command Line Arguments

(See [Communication](#) on page 30 for details about /Socket, /Telnet, /Inst, /HiSLIP, /AutoID, /NoAutoID, /FallBack).

Table 3 Command line arguments

Option	Description
/Socket socketPort	Set the socket port at which the Soft Front Panel waits for SCPI commands.
/Telnet telnetPort	Set the telnet port at which the Soft Front Panel waits for SCPI commands.
/Inst instrumentNumber	Set the instrument number (instN, hislipN) at which the Soft Front Panel waits for SCPI commands on VXI-11.3 and HiSLIP connections (if not specified with /HiSLIP).
/HiSLIP hislipNumber	Set the instrument number for HiSLIP SCPI communication. If not specified, the same number as for VXI-11.3 is used.
/AutoID	Automatically select ports and numbers for the connections (default behavior).
/NoAutoID	Disable the default behavior; i.e. do not automatically select ports and numbers for the connections.
/FallBack	Try to find unused ports and number if starting a server fails.
/NoSplash	Don't show the splash screen.
/Minimized	Start with the SFP window minimized to the Windows task bar.
/Title "title"	Additional information shown in the SFP window title.
/OutputDir	Set the output directory for the log file and temporary files.
/r resourceName	Visa PXI resource string of the module to connect to, e.g. PXI12::0::0::INSTR. "auto" selects the next free instrument.
/M8132TenGbe	Starts up the M8132A with three ODI ports and eight 10 GbE ports instead of the usual four ODI ports.

Communication

Depending on the command line arguments `/Socket`, `/Telnet`, `/Inst`, `/AutoID`, `/NoAutoID`, `/Fallback`, the Soft Front Panel starts several servers to handle SCPI commands. (Refer to the table above.)

/Socket, /Telnet, /Inst, /HiSLIP: If -1, do not start the respective servers

Defaults:

- Socket port: 5025 (e.g. TCPIP0::localhost::5025::SOCKET)
- Telnet port: 5024
- HiSLIP: 0 (e.g. TCPIP0::localhost::hislip0::INSTR)
- VXI-11.3: 0 (e.g. TCPIP0::localhost::inst0::INSTR)

/Fallback: If starting a server fails because of a conflict, try using another port or number

- HiSLIP, VXI-11.3: increase the index until a server can be started successfully
- Socket, Telnet: start with port 60000, then increase it until the servers can be started successfully. If neither socket nor telnet is disabled, the Soft Front Panel tries to start the servers on two consecutive ports (socket port = telnet port + 1)

/AutoID: Automatically select ports and number for the connections, which are unique per instrument.

This is the default behavior; it is not necessary to specify this argument on the command line.

If only one AXIe module is connected to this PC and it is an M8132A module, first try to use the command line arguments `/Socket`, `/Telnet`, `/Inst`, or their respective default values if they are not specified. If starting the servers fails, proceed with the steps below.

`/Socket`, `/Telnet`, `/Inst`, `/HiSLIP` are ignored (unless they are -1 and a server is disabled)

If the Soft Front Panel detects more than one AXIe module, use a special mechanism to obtain a number for the HiSLIP and VXI-11.3 servers, which makes sure that the Soft Front Panel uses always the same VISA resource string per module

The socket and telnet port are then calculated from the HiSLIP index:

- telnet port = 60000 + 2 * <HiSLIP index>
- socket port = 60000 + 2 * <HiSLIP index> + 1

NOTE

Ports may already be in use by Windows or other applications, so they are not available for M8132A.

/NoAutoID: Do not automatically select ports and number for the connections, use the values specified with /Socket, /Telnet, /Inst, /HiSLIP or their respective default values instead.

If both /NoAutoID and /AutoID are specified, /AutoID overrides /NoAutoID.

NOTE

The first port not assigned by IANA is 49152 (IANA, Internet Assigned Numbers Authority, <http://www.iana.org>)

Soft Front Panel

The **Soft Front Panel** and its elements are illustrated in the following figure:



Figure 5 M8132A user interface

The Soft Front Panel includes the following elements:

- 1 Title Bar
- 2 Menu Bar
- 3 Tabs (Clock, IOs and System Monitor)
- 4 Lower Pane
- 5 Status Bar

The detailed information on these GUI elements are described in the sections that follow.

Title Bar

The title bar contains the standard Microsoft Windows elements such as the window title and the icons for minimizing, maximizing, or closing the window.

Menu Bar

The menu bar consists of various pull-down menus that provide access to the different functions and launch interactive GUI tools.

The menu bar includes the following pull-down menus:

- File
- View
- Utilities
- Tools
- Help

Each menu and its options are described below.

File Menu

The **File** menu includes the following selections:

File > Connect...	Opens the “Connect to Instrument” dialog. See Launching the Soft Front Panel on page 26.
File > Save Configuration As...	Saves configuration as a text file. This feature is not implemented in the current software release.
File > Load Configuration...	Loads the previously saved configuration file. This feature is not implemented in the current software release.
File > Exit	Exits the M8132A application.

View Menu

The **View** menu includes the following selections:

View > Hide	Minimizes the GUI to notify icon.
-------------	-----------------------------------

Utilities Menu

The **Utilities** menu includes the following selections:

Utility > Identify	Identifies the instrument by flashing the green “Access” LED on the front panel for a certain time.
Utility > Reset	Resets the instrument, reads the state and updates all fields.
Utility > Self Test...	Opens a window to start the self-test and display the result after completion. Not functional in the current software release.

Tools Menu

The **Tools** menu includes the following selections:

Tools > Clock	Switch to the “Clock” tab on Parameters window if it is already open. If not, it adds “Clock” tab first. For details, see Clock Tab on page 38.
Tools > IOs	Switch to the “IOs” tab on Parameters window if it is already open. If not, it adds “IOs” tab first. For details, see IOs Tab on page 39.
Tools > System Monitor	Switch to the “System Monitor” tab on Parameters window if it is already open. If not, it adds “System Monitor” tab first. For details, see System Monitor Tab on page 51.



Help Menu

The **Help** menu includes the following selections:

Help > User Guide	Opens the M8132A User's Guide.
Help > Examples	Opens the Examples directory.
Help > Online Support	Opens the instrument's product support web page.
Help > About	Displays product information including version number, build date, build info, installed licenses, available options and web links for M8132A information and support.

Lower Pane

The lower pane provides the following options:

	Show Status Window	Opens the Status Window. This feature is currently not implemented.
	Show Error List Window	Opens the window that shows the list of errors and warnings. For details, see Errors List Window on page 36

Errors List Window

Use this window to view errors, warnings, and information.

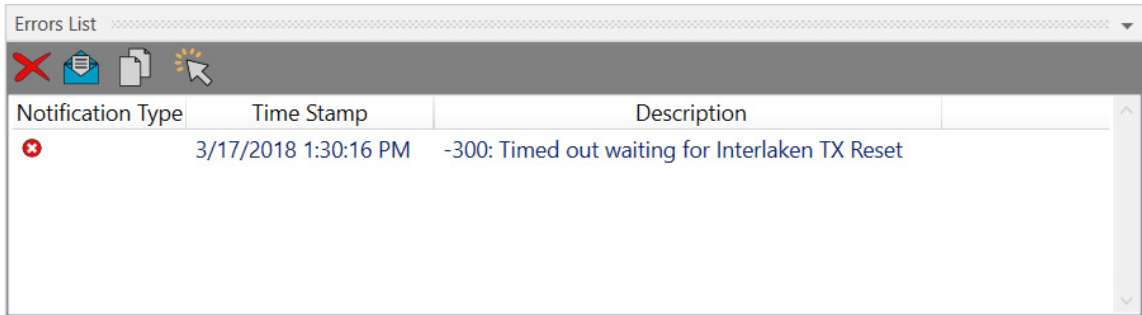

Figure 6 Error list window

For each error, it shows error details i.e. notification type, time stamp and description.

It has the following controls, signs, and columns:

	(Clear All)	Click this button to clear all the errors from the errors list window.
	Open On Error	Click this toggle button to automatically open the errors list window whenever an error occurs (default) or not.
	Copy	Click this button to copy the selected message(s).
	Select All	Click this button to select all messages inside the list.

Status Bar

The status bar contains the following fields from left to right:

- Connection state:
 - “Not Connected” – No instrument is connected.
 - “Connected: <Instrument resource string>” – An instrument is connected. The resource string, for example PXI36::0::0::INSTR is displayed.
 - “Simulation Mode” – No real instrument is connected. The user interface is in simulation mode. Click this field to open the Instrument Selection Dialog.
- Instrument status - Displays the instrument status, for example “Reset complete” after issuing a reset command.

Clock Tab

The **Clock** tab provides the clock settings to M8132A module.

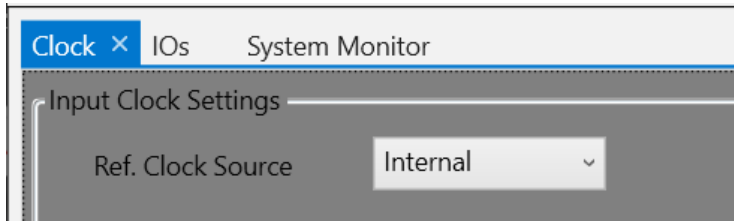

Figure 7 Clock tab

Input Clock Settings

- **Ref. Clock Source** - A clock reference input is provided on the front panel of the M8132A module. The options are:
 - Internal
 - External 100MHz

IOs Tab

The **IOs** tab provides input and output settings for optical data interfaces.

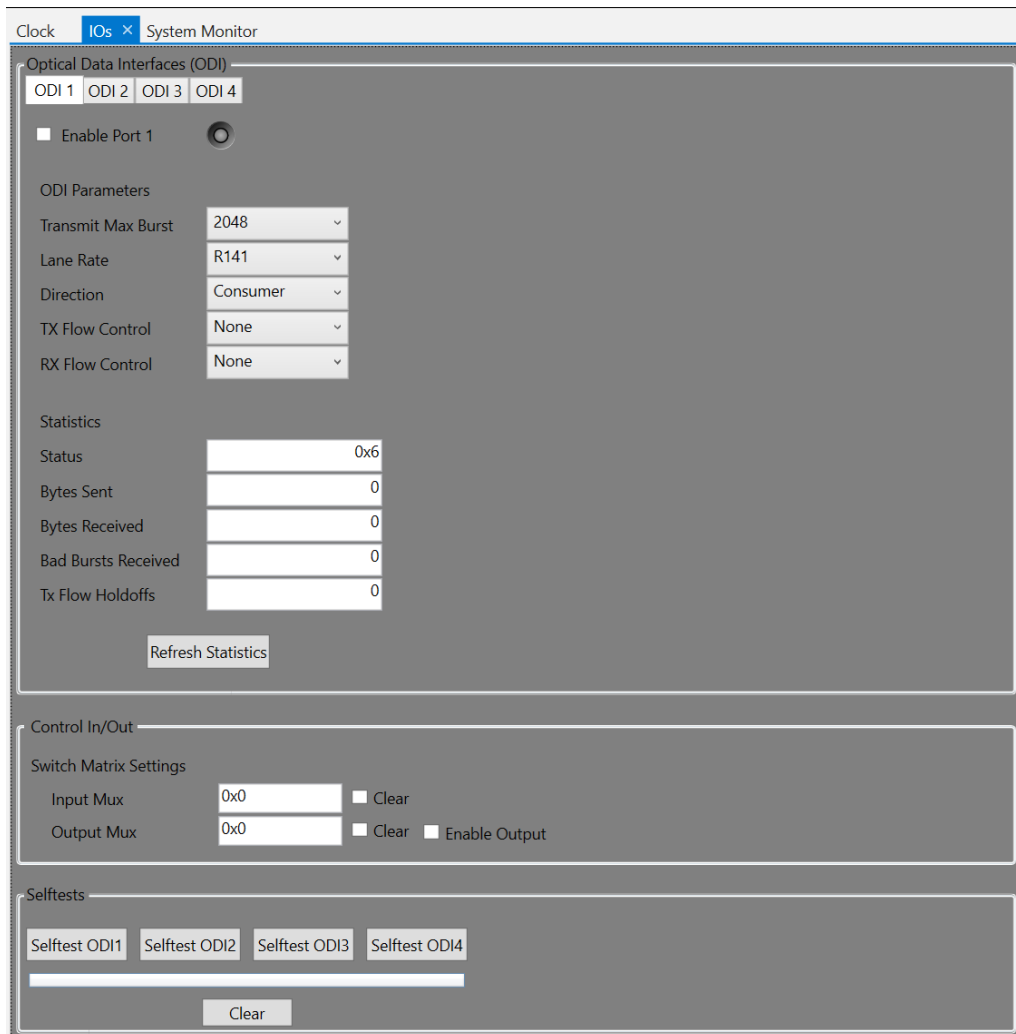

Figure 8 IOs tab

- **Optical Data Interfaces (ODI)** – Select an ODI from ODI1, ODI2, ODI3, or ODI4 to set the respective parameters.
- **Enable Port** – The respective ODI ports can be activated/deactivated by selecting this checkbox. An error for loss of signal will be shown, if a checkbox is asserted without making the physical connections.
- **ODI Parameters** – The following ODI Parameters are available:
 - **Transmit Max Burst** – This is the maximum burst size.
 - **Lane Rate** – Currently R141 is the only supported lane rate.
 - **Direction** – Select an option.
 - Bidirectional
 - Producer
 - Consumer
 - **TX Flow Control** – Select an option for the transmit flow control.
The following options are available:
 - **None** – No flow control.
 - **In Band** – In-band flow control.
 - **RX Flow Control** – Select an option for the receive flow control.
The following options are available:
 - **None** – No flow control.
 - **In Band** – In-band flow control.
- **Statistics** – Display the ODI statistics. The following options are available:
 - **Status** – It is a hexadecimal value that corresponds to a 32-bit register, which shows the current status of the port. Hover on the numeric field to open the tooltip, which provides information about every bit and its current value.
 - **Bytes Sent** – Number of bytes sent over the ODI link.
 - **Bytes Received** – Number of bytes received over the ODI link.
 - **Bad Bursts Received** – Number of bad bursts received over the ODI link.
 - **Tx Flow Holdoffs** – The number of ODI clock cycles during which the transmitter was held off, irrespective of whether there was something to transmit or not.
 - **Refresh Statistics**: Reset the ODI statistics.
- **Control In/Out** – For information on Control In/Out, refer to **Control In/Out Commands** on page 104.

- **Selftests** - This option tests whether the particular ODI port is functional or not. Connect a loopback connector to the respective port and run a self-test. It will test whether the port allows proper transmission of data. The test reports the connection status, and in case of failure, the status of each individual lane. All failed test steps are shown. Possible errors are PLL lock failures, burst, overflow, underflow, CRC, and alignment errors.

IOs Tab in 10GbE mode

When opened through the command line argument `/M8132TenGbE`, the M8132A displays three ODI ports and eight 10 GbE ports instead of the usual four ODI ports. The ODI4 tab is replaced with 10 GbE, and the Selftest ODI4 button is replaced with Selftest 10 GbE.



- On the **IOs** tab, click **10GbE** tab.

The screenshot displays the 'IOs System Monitor' window with the '10GbE' tab selected. The interface is divided into three main sections: 'Optical Data Interfaces (ODI)', 'Control In/Out', and 'Selftests'.

Optical Data Interfaces (ODI)

At the top, there are tabs for 'ODI 1', 'ODI 2', 'ODI 3', and '10GbE'. Below these is a section for '8 x 10 GbE Ports (ODI4)' with tabs for 'Port 1' through 'Port 8'. The 'Port 1' tab is active.

Under 'Port 1', there is a checkbox for 'Enable 10GbE Port 1' which is checked. Below this is the '10 GbE Parameters' section, which includes:

- 'Modify Advanced Parameters' (unchecked)
- 'Override Source MAC' (checked) with a value of '82:09:02:00:00:00'
- 'Override Dest MAC' (unchecked) with a value of '00:00:00:00:00:00'
- 'Override EtherType' (unchecked) with a value of '0x800'

The 'Statistics' section contains a table with three columns: 'Statistics', 'Result', and 'Rate (/s)'. The data is as follows:

Statistics	Result	Rate (/s)
Status	0x6	
Bytes Sent	0	0
Bytes Received	0	0
Rx Good Frames	0	0
Rx Bad Frames	0	0
Rx Dropped Frames	0	0

A 'Reset Statistics' button is located below the statistics table.

Control In/Out

This section contains 'Switch Matrix Settings' with two rows:

- 'Input Mux' with a value of '0x0' and a 'Clear' button.
- 'Output Mux' with a value of '0x0', a 'Clear' button, and an 'Enable Output' checkbox.

Selftests

This section has tabs for 'Selftest ODI1', 'Selftest ODI2', 'Selftest ODI3', and 'Selftest 10GbE'. The 'Selftest 10GbE' tab is active. Below the tabs is a progress bar and a 'Clear' button.

The following options are available in the **10GbE** tab.

- **8 * 10 GbE Ports (ODI4)** - A panel containing tabs for the 10 GbE ports is displayed. There are eight available ports. Each 10 GbE port can be independently controlled using its own tab.
- **Enable 10GbE Port 1** - The option enables/disables the 10GbE port.
- **LED Color** - The LED next to **Enable 10GbE Port 1** option displays the following colors:
 - **Grey** - Not Enabled
 - **Dark** - Enabled, no optical signal detected (LOS)
 - **Yellow** - Enabled, optical signal detected but Receiver Valid Ctrl Code not detected
 - **Green** - Enabled, Receiver Valid Ctrl Code detected

The LED color is updated approximately once per second.
The LED behavior is more consistent between 10 GbE and ODI when there is LOS (Loss of Optical Signal).
- **10GbE Parameters** - These parameters can be used to set selected fields in transmitted Ethernet Frames. As changing the fields controlled by the Override parameters may cause networking problems, access to these parameters is protected by a checkbox and warning tooltip.

NOTE

Advanced Setting Tooltip: All of the 10 GbE parameters display the same tooltip (when enabled). The tooltip disappears after 5s.

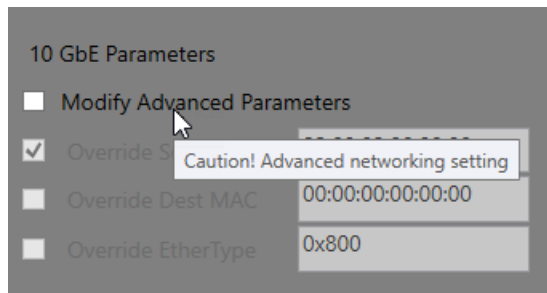

The following parameters cannot be changed when the port is enabled.

- **Modify Advanced Parameters** - It allows modification of the Override settings (Source MAC, Dest MAC, and EtherType).

When “Modify Advanced Parameters” is checked, you can access the override settings.

10 GbE Parameters

<input checked="" type="checkbox"/> Modify Advanced Parameters	
<input checked="" type="checkbox"/> Override Source MAC	82:09:02:00:00:00
<input type="checkbox"/> Override Dest MAC	00:00:00:00:00:00
<input type="checkbox"/> Override EtherType	0x800

When “Modify Advanced Parameters” is unchecked, override settings cannot be changed (greyed out). This is the default view.

10 GbE Parameters

<input type="checkbox"/> Modify Advanced Parameters	
<input checked="" type="checkbox"/> Override Source MAC	82:09:02:00:00:00
<input type="checkbox"/> Override Dest MAC	00:00:00:00:00:00
<input type="checkbox"/> Override EtherType	0x800

NOTE

The “Modify Advanced Parameters” checkbox cannot be modified while the 10 GbE port is enabled.

- **Override Source MAC** - When checked, the source MAC address field in each transmitted packet will use the parameter value. When unchecked, the source MAC address field is transmitted unchanged from the CAA design.

Parameter Value: Hexadecimal formatted 48 bit source MAC address.

Reset: A unique locally-administered value created from the instrument serial number and ethernet port number of form 82:09:02:xx:xx:xx

- **Override Dest MAC** - When checked, the destination MAC address field in each transmitted packet will use the parameter value. When unchecked, the destination MAC address field is transmitted unchanged from the CAA design.

Parameter Value: Hexadecimal formatted 48 bit destination MAC address

Reset: 00:00:00:00:00:00

- **Override EtherType** - When checked, the EtherType in each transmitted packet will use the parameter value. When unchecked, the EtherType field is transmitted unchanged from the CAA design.

Parameter Value: Hexadecimal formatted two octet EtherType

Reset: 0x800

- **Statistics** - This section of the panel displays the current 10 GbE port statistics. The statistics are updated approximately once per second. For all results apart from Status, there are two columns:
 - **Results** - Displays the cumulative total result count since the last time the Port was enabled (or the Reset Statistics button was pressed)
 - **Rate (/s)** - Displays the rate calculated over approximately the last one second.

The following Statistics are available:

- **Status** - Displays the status of the port. Status bits are latched between the approximately once per second screen updates. All bits are reset when the port is enabled. A value of 0 is expected during error-free normal operation.

Bit0: Optical LOS

Bit1: !STAT_RX_VALID_CTRL_CODE

Bit2: !STAT_RX_BLOCK_LOCK_REG

Bit3: Unused

Bit4: STAT_RX_HI_BER

Bit5: STAT_RX_REMOTE_FAULT

Bit6: STAT_RX_LOCAL_FAULT

Bit7: STAT_RX_INTERNAL_LOCAL_FAULT

Bit8: STAT_RX_RECEIVED_LOCAL_FAULT

Bit9: STAT_RX_BAD_PREAMBLE"

Bit10: STAT_RX_BAD_SFD
 Bit11: STAT_RX_GOT_SIGNAL_OS
 Bit12: STAT_TX_LOCAL_FAULT
 Bit13: STAT_TX_FRAMING_ERROR
 Bits 14-15: Unused
 Bit16: STAT_TXUNFOUT

NOTE

The Status tooltip decodes the current status value and is on a timer, so it disappears after 15s. The names are cryptic but should match names in Xilinx documentation.

Statistics	Result	Rate (/s)
Status	0x6	Bit0: Optical LOS = 0 Bit1: !STAT_RX_VALID_CTRL_CODE = 1 Bit2: !STAT_RX_BLOCK_LOCK_REG = 1 Bits 3: Unused Bit4: STAT_RX_HI_BER = 0 Bit5: STAT_RX_REMOTE_FAULT = 0 Bit6: STAT_RX_LOCAL_FAULT = 0 Bit7: STAT_RX_INTERNAL_LOCAL_FAULT = 0 Bit8: STAT_RX_RECEIVED_LOCAL_FAULT = 0 Bit9: STAT_RX_BAD_PREAMBLE = 0 Bit10: STAT_RX_BAD_SFD = 0 Bit11: STAT_RX_GOT_SIGNAL_OS = 0 Bit12: STAT_TX_LOCAL_FAULT = 0 Bit13: STAT_TX_FRAMING_ERROR = 0 Bits 14-15: Unused Bit16: STAT_TXUNFOUT = 0
Bytes Sent		
Bytes Received		
Rx Good Frames		
Rx Bad Frames		
Rx Dropped Frames		
	Reset Statistics	

- **Bytes Sent** - The result displays the number of transmitted bytes. The byte count is reset to 0 when the port is enabled, or the Reset Statistics button is pressed. Rate displays the number of bytes per second transmitted over the previous second.
- **Bytes Received** - The result displays the number of received bytes. The byte count is reset to 0 when the port is enabled, or the Reset Statistics button is pressed. Rate displays the number of bytes per second received over the previous second.

- **Rx Good Frames** - The result displays the number of received good frames (packets). The packet-count is reset to 0 when the port is enabled, or the Reset Statistics button is pressed. Rate displays the number of good frames per second received over the previous second.
- **Rx Bad Frames** - The result displays the number of received bad frames (packets). The packet-count is reset to 0 when the port is enabled, or the Reset Statistics button is pressed. (Bad packets are calculated as the difference between total packets and good packets) Rate displays the number of bad frames per second received over the previous second.
- **Rx Dropped Frames** - The result displays the number of received dropped packets. The packet-count is reset to 0 when the port is enabled, or the Reset Statistics button is pressed. (Dropped packets are calculated as the sum of undersize, oversize and packets with bad FCS) Rate displays the number of dropped frames per second received over the previous second.
- **Reset Statistics** - Resets the port statistics to 0. It does not reset port operation.
- **Selftest 10 GbE** - It enables all eight ports and checks that an optical signal is received on each port and that each receiver detects the Valid Ctrl Code. This action affects all eight ports, not only the currently selected port. When button is pressed, a popup appears:

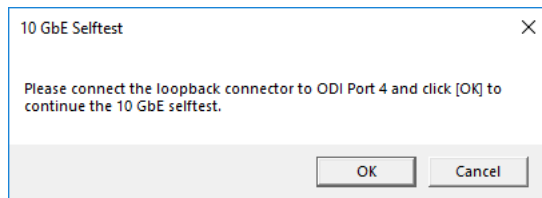

If all parts of the test pass, then “Passed” is displayed.



If any part of the test fails, then all pass / fail results are shown.

Selftests

Selftest ODI1 Selftest ODI2 Selftest ODI3 Selftest 10GbE

Name	Result
TENGBE Port1 Rx Valid Ctrl Code	Failed
TENGBE Port1 Optical Signal Detected	Failed
TENGBE Port2 Rx Valid Ctrl Code	Failed
TENGBE Port2 Optical Signal Detected	Failed
TENGBE Port3 Rx Valid Ctrl Code	Passed
TENGBE Port3 Optical Signal Detected	Passed
TENGBE Port4 Rx Valid Ctrl Code	Passed
TENGBE Port4 Optical Signal Detected	Passed
TENGBE Port5 Rx Valid Ctrl Code	Passed
TENGBE Port5 Optical Signal Detected	Passed
TENGBE Port6 Rx Valid Ctrl Code	Passed
TENGBE Port6 Optical Signal Detected	Passed
TENGBE Port7 Rx Valid Ctrl Code	Failed
TENGBE Port7 Optical Signal Detected	Failed
TENGBE Port8 Rx Valid Ctrl Code	Failed
TENGBE Port8 Optical Signal Detected	Failed

Clear

Cabling for 10GbE Connectivity

When Ethernet operation is selected, Port 4 needs to use a special breakout cable (M8132A-830) that fans out the MTP/MPO connector to 8 LC Tx/Rx pairs to connect to SFP+ 10GbE optical connections. The link uses OM3 multimode cable and is compatible with 10GBASE-SR physical layer requirements of IEEE 802.3.

For information on 10GbE, refer to: IEEE 802.3 standards.

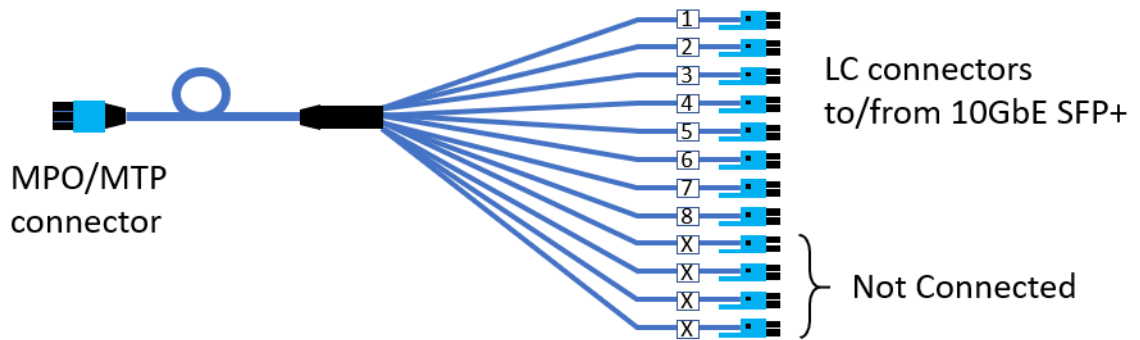

System Monitor Tab

Power Measurement

The M8132 is designed to supply 2 FPGAs within a total of 75W max per FPGA (VCCINT + MGTAVCC + MGTAVTT). In general, the module is protected against overcurrent and overtemperature. To ensure that the operation remains within limits, the user can measure the power consumption of the FPGAs in the System Monitor Tab. Such a query is recommended every time a new custom FPGA is loaded in the module, but before the query, the FPGAs should be configured in a mode that consumes the maximum power.

For more information about the queries via SCPI command, refer to [Remote Programming](#) on page 61.

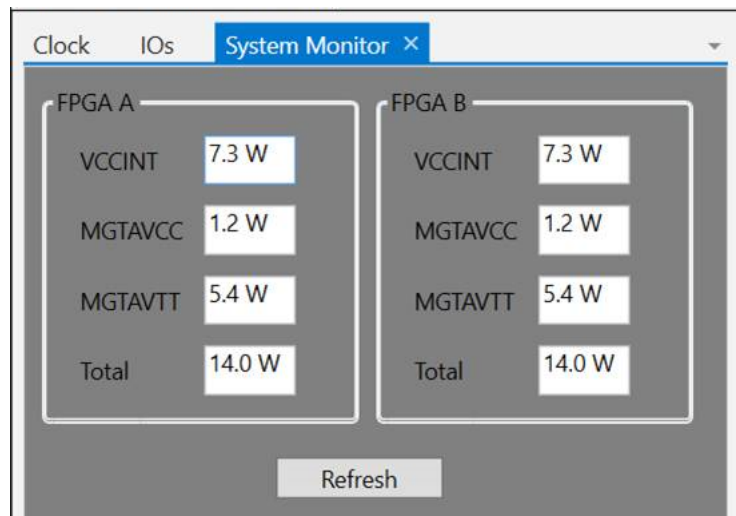

Figure 9 System Monitor tab

4 Control In/Out

Control In/Out and Trigger Input / 54

This chapter describes the Control In/Out and Trigger Input.

Control In/Out and Trigger Input

The interfaces of the sandboxes in the FPGA designs generated by PathWave FPGA contain the general-purpose pins GP_TRIG_IN (0..2) as input ports and GP_TRIG_OUT (0..2) as output ports.

The front panel input ports “Control In/Out (0..4)” and the trigger input “Trig In” can be routed to GP_TRIG_IN(0..2) and the output ports “Control In/Out (5..9)” can be sourced by GP_TRIG_OUT (0..2) of each FPGA.

The following picture shows the switch matrix that allows to configure the connections between the front panel and the sandbox ports:

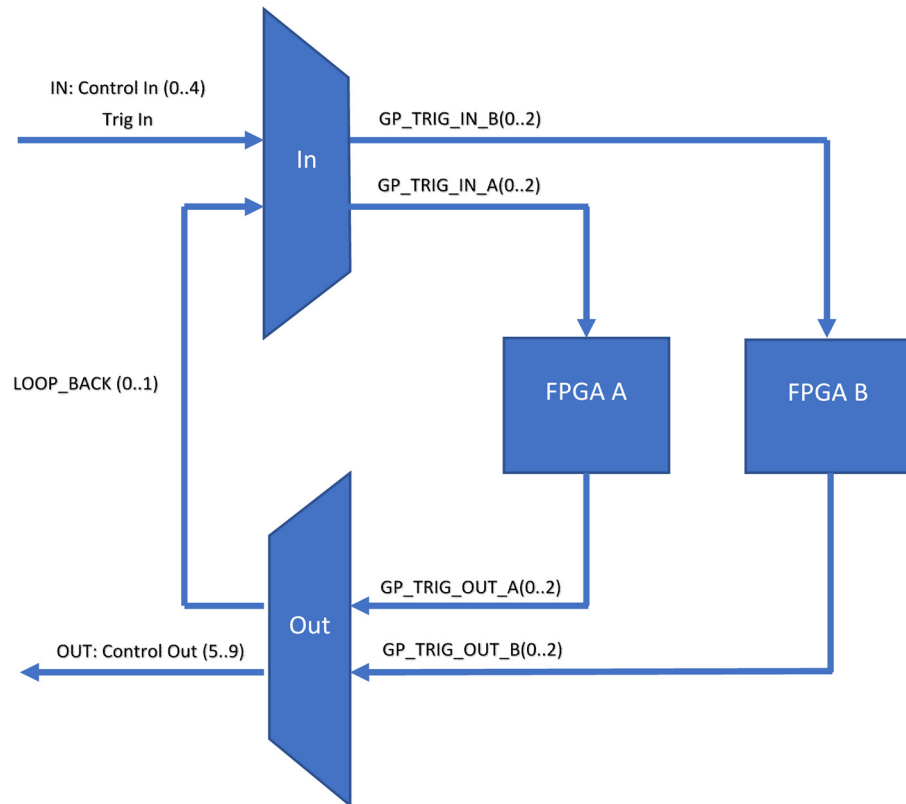

The Control In/Out (0..9) port is separated in 5 inputs (Control In (0..4)) and 5 outputs (Control Out (5..9)). Each multiplexer has a separate clear mechanism that sets all outputs of the corresponding multiplexer to zero. Additionally, it is possible to disable the output ports of Control Out (5..9). This sets the ports to “high impedance”.

All input sources for each multiplexer can be routed to each output. The switch matrix is clocked with a 200 MHz clock, and therefore all inputs are synchronized to this clock. After input synchronization, the transmission is cycle accurate.

Example: When routing the Control In (0) to both FPGAs, the connected signal is synchronized to the 200 MHz clock. So, there is an input accuracy of 5ns. Once synchronized to this clock, the transmission is cycle accurate, which means that the connected signal information will arrive at the sandbox port of both FPGAs at the same time.

The LOOP_BACK (1..0) connection allows to transfer of information between the two FPGA sandboxes synchronously.

Input Multiplexer of the Switch Matrix

Four bits are used to select the source for each output of the input multiplexer. The corresponding bit positions inside the selector field in the soft front panel are specified in the following table.

Table 4 Bit Positions for Output Ports of the Input Multiplexer of the Switch Matrix

Bit Positions	Output Port
23..20	GP_TRIG_IN_B(2)
19..16	GP_TRIG_IN_B(1)
15..12	GP_TRIG_IN_B(0)
11..8	GP_TRIG_IN_A(2)
7..4	GP_TRIG_IN_A(1)
3..0	GP_TRIG_IN_A(0)

The corresponding input ports are coded as shown in the following table:

Table 5 Coding of Input Ports of the Input Multiplexer of the Switch Matrix:

Value (binary)	Port
0000	Control In (0)
0001	Control In (1)
0010	Control In (2)
0011	Control In (3)
0100	Control In (4)
0101	Trig In
0110	Reserved, do not use
0111	Reserved, do not use
1000	LOOP_BACK (0)
1001	LOOP_BACK (1)

Output Multiplexer of the Switch Matrix

Three bits are used to select the source for each output of the output multiplexer. The corresponding bit positions inside the selector field in the soft front panel are specified in the following table.

Table 6 Bit Positions for Output Ports of the Output Multiplexer of the Switch Matrix

Bit Positions	Output Port
20..18	LOOP_BACK (1)
17..15	LOOP_BACK (0)
14..12	Control Out (9)
11..9	Control Out (8)
8..6	Control Out (7)
5..3	Control Out (6)
2..0	Control Out (5)

The corresponding input ports are coded as shown in the following table:

Table 7 Coding of Input Ports of the Output Multiplexer of the Switch Matrix

Value (binary)	Port
000	GP_TRIG_OUT_A(0)
001	GP_TRIG_OUT_A(1)
010	GP_TRIG_OUT_A(2)
011	GP_TRIG_OUT_B(0)
100	GP_TRIG_OUT_B(1)
101	GP_TRIG_OUT_B(2)

Trigger Input

The trigger input (Trig In) is connected to a trigger generator that produces a trigger pulse on each rising edge of the connected input signal. The trigger threshold can be set via remote programming interface (SCPI). For more details on trigger specification, refer to the datasheet of the instrument.

5 Using KF 9000B PathWave FPGA with the M8132A

PathWave FPGA KF9000B must be used as the design tool to program the sand boxes of the Xilinx FPGA inside the M8132A.

Additional documentation can be found at:

- <http://www.keysight.com/products/KF9000B> for KF9000B PathWave FPGA related documentation.
- <http://www.keysight.com/find/M8132A> for M8132A FSP related documentation.

6 Remote Programming

Remote Programming Overview	/ 62
Status Commands	/ 64
Latency Calibration Commands	/ 70
Common Commands	/ 72
System Commands	/ 75
Time Base Commands	/ 80
Instrument Commands	/ 81
FPGA Access Commands	/ 82
Current and Power Monitor Commands	/ 85
Sandbox Commands	/ 88
Optical Data Interface Commands	/ 95
Trigger Commands	/ 102
Control In/Out Commands	/ 104
TEST Commands	/ 107
Ethernet Commands	/ 108

Remote Programming Overview

This chapter introduces the basics for remote programming of an M8132A instrument using SCPI commands.

Instructions

Instructions, both commands and queries, normally appear as strings embedded in a statement of your host language, such as Visual Basic for Applications (VBA), Visual Basic .NET, C#, C, etc.

The only time a parameter is not meant to be expressed as a string is when the instruction's syntax definition specifies `<binary_block_data>`, such as with the `:SYSTEM:SET` command. There are only a few instructions that use block data.

Instructions are composed of two main parts:

- The header, which specifies the command or query to be sent.
- The program data, which provides additional information to clarify the meaning of the instruction.

Instruction Header

The instruction header is one or more command mnemonics separated by colons (:). They represent the operation to be performed by the instrument. Queries are formed by adding a question mark (?) to the end of the header. Many instructions can be used as either commands or queries, depending on whether or not you include the question mark. The command and query forms of an instruction usually have different program data. Many queries do not use any program data.

White Space (Separator)

White space is used to separate the instruction header from the program data. If the instruction does not require any program data parameters, you do not need to include any white space. In this manual, white space is defined as one or more spaces. ASCII defines a space to be character 32 in decimal.

Braces

When several items are enclosed by braces, { }, only one of these elements may be selected. Vertical line (|) indicates "or". For example, {ON | OFF} indicates that only ON or OFF may be selected, not both.

Ellipsis

... An ellipsis (trailing dots) indicates that the preceding element may be repeated one or more times.

Square Brackets

Items enclosed in square brackets, [], are optional.

Program Data

Program data is used to clarify the meaning of the command or query. It provides necessary information, such as whether a function should be on or off, or which waveform is to be displayed. Each instruction's syntax definition shows the program data and the values they accept.

When there is more than one data parameter, they are separated by commas (,). You can add spaces around the commas to improve readability.

Status Commands

This section describes the structure of the SCPI status system used by the M8132A. The status system records various conditions and states of the instrument in several register groups as shown on the following pages. Each of the register groups is made up of several low level registers called Condition registers, Event registers, and Enable registers which control the action of specific bits within the register group.

These groups are explained below:

A condition register continuously monitors the state of the instrument. The bits in the condition register are updated in real time and the bits are not latched or buffered. This is a read-only register and bits are not cleared when you read the register. A query of a condition register returns a decimal value which corresponds to the binary-weighted sum of all bits set in that register.

An event register latches the various events from changes in the condition register. There is no buffering in this register; while an event bit is set, subsequent events corresponding to that bit are ignored. This is a read only register. Once a bit is set, it remains set until cleared by query command (such as `STAT:QUES:EVENT?`) or a `*CLS` (clear status) command. A query of this register returns a decimal value which corresponds to the binary-weighted sum of all bits set in that register.

An enable register defines which bits in the event register will be reported to the Status Byte register group. You can write to or read from an enable register. A `*CLS` (clear status) command will not clear the enable register but it does clear all bits in the event register. A `STAT:PRES` command clears all bits in the enable register. To enable bits in the enable register to be reported to the Status Byte register, you must write a decimal value which corresponds to the binary weighted sum of the corresponding bits.

Transition Filters are used to detect changes of the state in the condition register and set the corresponding bit in the event register. You can set transition filter bits to detect positive transitions (PTR), negative transitions (NTR) or both. Transition filters are read/write registers. They are not affected by `*CLS`.

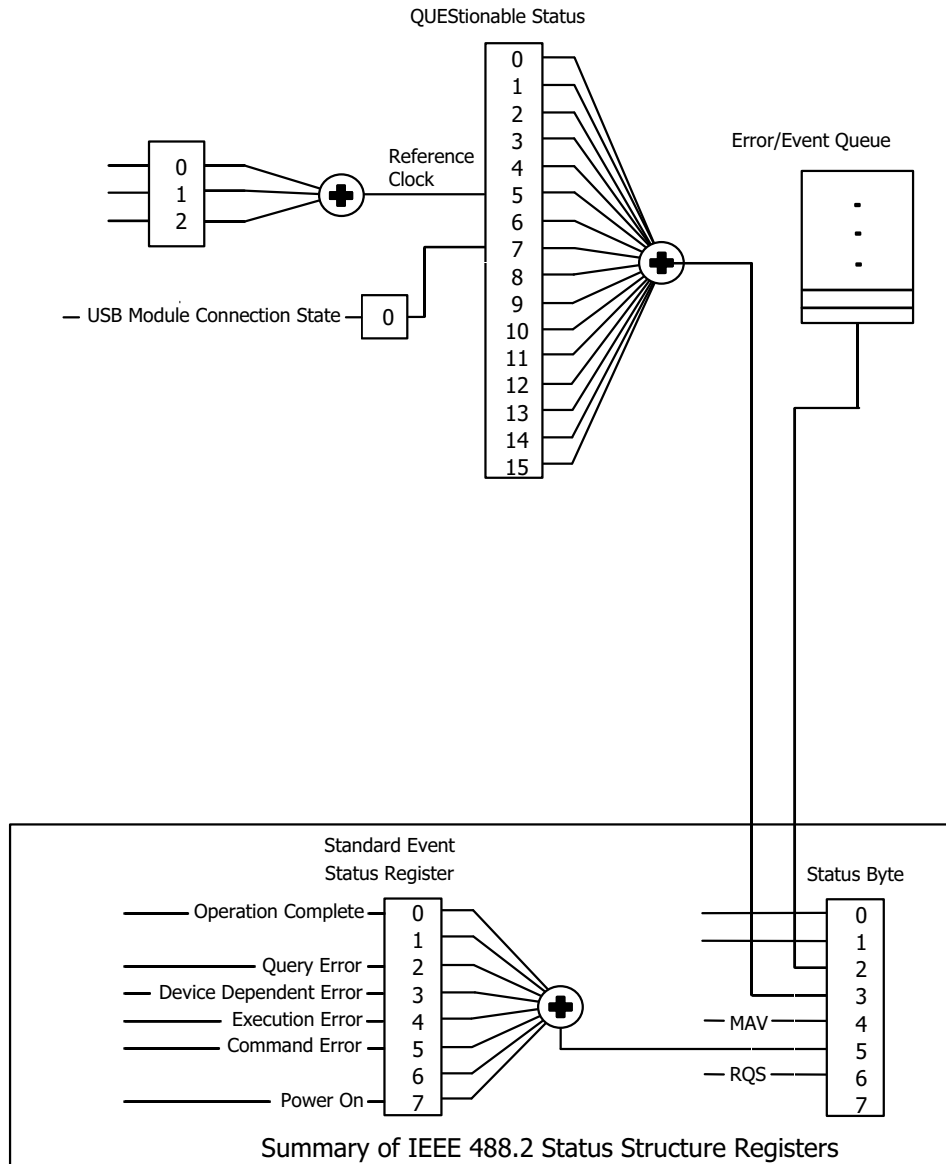

Figure 10 Status register structure

STATus:PRESet

Clears all status group event registers. Presets the status group enables PTR and NTR registers as follows:

```
ENABLe = 0x0000, PTR = 0xffff, NTR = 0x0000
```

Status Byte Register

The Status Byte summary register reports conditions from the other status registers. Data that is waiting in the instrument's output buffer is immediately reported on the "Message Available" bit (bit 4) for example. Clearing an event register from one of the other register groups will clear the corresponding bits in the Status Byte condition register. Reading all messages from the output buffer, including any pending queries, will clear the "Message Available" bit. To set the enable register mask and generate an SRQ (service request), you must write a decimal value to the register using the *SRE command.

Table 8 Status byte register

Bit Number		Decimal Value	Definition
0	Not used	1	Not Used. Returns "0"
1	Not used	2	Not Used. Returns "0"
2	Error Queue	4	One or more errors are stored in the Error Queue
3	Questionable Data	8	One or more bits are set in the Questionable Data Register (bits must be enabled)
4	Message Available	16	Data is available in the instrument's output buffer
5	Standard Event	32	One or more bits are set in the Standard Event Register
6	Master Summary	64	One or more bits are set in the Status Byte Register
7	Operational Data	128	One or more bits set in the Operation Data Register (bits must be enabled)

Questionable Data Register Command Subsystem

The Questionable Data register group provides information about the quality or integrity of the instrument. Any or all of these conditions can be reported to the Questionable Data summary bit through the enable register.

Table 9 Questionable data register

Bit Number		Decimal Value	Definition
0	Not used	1	Returns "0"
1	Not used	2	Returns "0"
2	Not used	4	Returns "0"
3	Not used	8	Returns "0"
4	Not used	16	Returns "0"
5	Reference Clock Status	32	Instable or missing external reference clock.
6	Not used	64	Returns "0"
7	USB disconnected	128	USB module connection state
8	Not used	256	Returns "0"
9	Not used	512	Returns "0"
10	Not used	1024	Returns "0"
11	Not used	2048	Returns "0"
12	Not used	4096	Returns "0"
13	Not used	8192	Returns "0"
14	Not used	16384	Returns "0"
15	Not used	32768	Returns "0"

Reference Clock Status Subsystem

The Reference Clock Status register contains information about the validity of the 100 MHz external reference clock of the module

The following SCPI commands and queries are supported:

```
:STATus:QUEStionable:REFClock[:EVENT]?
:STATus:QUEStionable:REFClock:CONDition?
:STATus:QUEStionable:REFClock:ENABle[?]
:STATus:QUEStionable:REFClock:NTRansition[?]
:STATus:QUEStionable:REFClock:PTRansition[?]
```

Table 10 Reference clock status register

Bit Number		Decimal Value	Definition
0	Amplitude too small	1	Amplitude of external reference signal too small or no signal.
1	Not used	2	Returns "0"
2	Frequency out-of-range	4	Frequency of external reference signal out-of-range.

Connection Status Subsystem

The Connection Status register contains the state of the USB connection to the M8132A module.

The following SCPI commands and queries are supported:

```
:STATus:QUEStionable:CONNECTION[:EVENT]?
:STATus:QUEStionable:CONNECTION:CONDition?
:STATus:QUEStionable:CONNECTION:ENABle[?]
:STATus:QUEStionable:CONNECTION:NTRansition[?]
:STATus:QUEStionable:CONNECTION:PTRansition[?]
```

Table 11 Connection status register

Bit Number		Decimal Value	Definition
0	USB disconnected	1	USB module connection state

Latency Calibration Commands

The Latency Calibration commands are used to initialize the deterministic latency in the data path between the M8131A digitizer and the DSP. The digitizer, as the module connected upstream in the data path, will be referred to as the primary module in the command description. The DSP, as the module connected downstream in the data path, will be referred to as the secondary module. For deterministic latency initialization, a defined sequence of commands must be sent to primary module and secondary module. For more information, refer to the example program described in section “Continuous Streaming with Constant Latency to DSP Module” in the M8131A user guide.

`:CALibrate:LATency:LCMPeriod`

Command	<code>:CALibrate:LATency:LCMPeriod <lcm_period></code>
Description	This command sets the Least Common Multiple (LCM) period value to be used for core clock phase alignment. On the primary module, this value determines the frequency of the signal sent out at the Sync Out. On the secondary module, this value determines the frequency of the signal used to compare with the signal received at the Sync In. The formula for the frequency is: $f = 400\text{MHz} / \text{LCM period.}$ <code><lcm_period></code> The LCM period as an even integer between 2 and 32768.
Query	<code>:CALibrate:LATency:LCMPeriod?</code>
Description	This query returns the current LCM period.

`:CALibrate:LATency:MODE`

Command	<code>:CALibrate:LATency:MODE {SEParate COMBined}</code>
Description	This command selects the latency calibration mode. <ul style="list-style-type: none"> • SEParate – Phase alignment to the primary module’s core clock and latency calibration are separate steps. This mode is used for latency setup between M8131A and M8132A DSP. • COMBined - Phase alignment to the primary module’s core clock and latency calibration is done in the same step. This mode is used for the latency setup between M8131A and M8121A AWG.

:CALibrate:LATency[:STEP]

Command :CALibrate:LATency[:STEP] {GSYNc | ALIGnphase | SSYNc
| ARMadjust | PREPare}

Description This command executes a step in the latency calibration of the data path between the primary module and secondary module. As mentioned in brackets, some commands are sent to and affect only the primary module and some only the secondary module. It is indicated as well, when commands are relevant only for one calibration mode (SEParate, COMBined).

- GSYNc - Generate clock signal at Sync Out (primary module, SEParate).
- ALIGnphase - Use the clock signal received at Sync In to align the phase of the core clock (secondary module).
- SSYNc - Stop the clock signal generation at Sync Out (primary module).
- ARMadjust - Arm the module for latency adjustment (secondary module). When the primary module starts sending data over the ODI, the latency is measured in the secondary module, and the FIFOs are adjusted accordingly.
- PREPare - Set the Sync Out to pulse mode (primary module, SEParate). When data streaming is started, a single pulse is sent at the Sync Out.

:CALibrate:LATency:SPDelay

Command :CALibrate:LATency:SPDelay {A|B}, <sync_pulse_delay>

Description This command sets the synchronization pulse delay for the selected FPGA in multiples of the core clock period (5ns).

A Selects FPGA A.

B Selects FPGA B.

<sync_pulse_delay> The synchronization pulse delay as an unsigned integer between 0 and 1023.

Query :CALibrate:LATency:SPDelay? {A|B}

Description This query returns the synchronization pulse delay for the selected FPGA.

Common Commands

*IDN?

Read the instrument's identification string which contains four fields separated by commas. The first field is the manufacturer's name, the second field is the model number, the third field is the serial number, and the fourth field is a revision code which contains four numbers separated by dots and a fifth number separated by a dash:

```
Keysight Technologies, M8132A, <serial number>,
x.x.x.x-h
```

x.x.x.x= Soft Front Panel revision number, e.g. 2.0.0.0

h= Hardware revision number

*CLS

Clear the event register in all register groups. This command also clears the error queue and cancels a *OPC operation. It doesn't clear the enable register.

*ESE

Enable bits in the Standard Event Status Register to be reported in the Status Byte. The selected bits are summarized in the "Standard Event" bit (bit 5) of the Status Byte Register. The *ESE? query returns a value which corresponds to the binary-weighted sum of all bits enabled decimal by the *ESE command. These bits are not cleared by a *CLS command. Value Range: 0–255.

ESR?

Query the Standard Event Status Register. Once a bit is set, it remains set until cleared by a *CLS (clear status) command or queried by this command. A query of this register returns a decimal value which corresponds to the binary-weighted sum of all bits set in the register.

*OPC

Set the "Operation Complete" bit (bit 0) in the Standard Event register after the previous commands have been completed.

*OPC?

Return “1” to the output buffer after the previous commands have been completed. Other commands cannot be executed until this command completes.

*OPT?

Read the installed options. The response consists of any number of fields separated by commas.

*RST

Reset instrument to its factory default state.

*SRE[?]

Enable bits in the Status Byte to generate a Service Request. To enable specific bits, you must write a decimal value which corresponds to the binary-weighted sum of the bits in the register. The selected bits are summarized in the “Master Summary” bit (bit 6) of the Status Byte Register. If any of the selected bits change from “0” to “1”, a Service Request signal is generated. The *SRE? query returns a decimal value which corresponds to the binary-weighted sum of all bits enabled by the *SRE command.

*STB?

Query the summary (status byte condition) register in this register group. This command is similar to a Serial Poll but it is processed like any other instrument command. This command returns the same result as a Serial Poll but the “Master Summary” bit (bit 6) is not cleared by the *STB? command.

*TST?

Execute Self Tests. If self-tests pass, a 0 is returned. A number larger than 0 indicates the number of failed tests.

To get actual messages, use :TEST:TST?

*LRN?

Query the instrument and return a binary block of data containing the current settings (learn string). You can then send the string back to the instrument to restore this state later. For proper operation, do not modify the returned string before sending it to the instrument. Use `:SYST:SET` to send the learn string. See `:SYSTem:SET[?]` on page 76.

*WAI?

Prevents the instrument from executing any further commands until the current command has finished executing.

System Commands

:SYSTem:ERRor[:NEXT]?

Query :SYSTem:ERRor?

Description The query read and clear one error from the instrument's error queue.

A record of up to 30 command syntax or hardware errors can be stored in the error queue. Errors are retrieved in first-in-first-out (FIFO) order. The first error returned is the first error that was stored. Errors are cleared as you read them.

If more than 30 errors have occurred, the last error stored in the queue (the most recent error) is replaced with "Queue overflow". No additional errors are stored until you remove errors from the queue.

If no errors have occurred when you read the error queue, the instrument responds with 0, "No error".

The error queue is cleared by the *CLS command, when the power is cycled, or when the Soft Front Panel is re-started.

The error queue is not cleared by a reset (*RST) command.

The error messages have the following format (the error string may contain up to 255 characters):

error number,"Description", e.g.

-113,"Undefined header".

Example Query

```
:SYST:ERR?
```

:SYSTem:HELP:HEADers?

Query :SYSTem:HELP:HEADers?

Description The query returns all SCPI commands and queries and IEEE 488.2 common commands and common queries implemented by the instrument. The response is a <DEFINITE LENGTH ARBITRARY BLOCK RESPONSE DATA> element. The full path for every command and query is returned separated by linefeeds.

The syntax of the response is defined as: The <nonzero digit> and sequence of <digit> follow the rules in IEEE 488.2, Section 8.7.9. A <SCPI header> is defined as: It contains all the nodes from the root. The <SCPI program mnemonic> contains the node in standard SCPI format. The short form uses uppercase characters while the additional characters for the long form are in lowercase characters. Default nodes are surrounded by square brackets ([]).

Example Query
:SYST:HELP:HEAD?

:SYSTem:LICense:EXTended:LIST?

Query :SYSTem:LICense:EXTended:LIST?
Description The query lists the licenses installed.
Example Query
:SYST:LIC:EXT:LIST?

:SYSTem:SET[?]

Command :SYSTem:SET[?] <binary block data>
Description In query form, the command reads a block of data containing the instrument's complete set-up. The set-up information includes all parameter and mode settings, but does not include the contents of the instrument setting memories or the status group registers. The data is in a binary format, not ASCII, and cannot be edited.
In set form, the block data must be a complete instrument set-up read using the query form of the command.
This command has the same functionality as the *LRN command.
Parameters <binary block data>
Example Command
:SYST:SET <binary block data>
Query
:SYST:SET?

:SYSTem:VERSion?

Command	:SYSTem:VERSion?
Description	The query returns a formatted numeric value corresponding to the SCPI version number for which the instrument complies.
Example	Query :SYST:VERS?

:SYSTem:COMMunicate:*?

Command	:SYSTem:COMMunicate:*?
Description	The query returns information about the instrument Soft Front Panel's available connections. If a connection is not available, the returned value is -1. This is only useful if there is more than one Keysight module connected to a PC, otherwise one would normally use the default connections (HiSLIP and VXI-11 instrument number 0, socket port 5025, telnet port 5024) One can never be sure if a socket port is already in use, so one could e.g. specify a HiSLIP number on the command line (AgM8132SFP.exe /AutoID /Inst5 /FallBack /r ...) and let the Soft Front Panel find an unused socket port. Then this socket port can be queried using the HiSLIP connection.
Example	Query :SYST:COMM:*?

:SYSTem:COMMunicate:INSTr[:NUMBer]?

Command	:SYSTem:COMMunicate:INSTr?
Description	The query returns the VXI-11 instrument number used by the Soft Front Panel.
Example	Query :SYST:COMM:INST?

:SYSTem:COMMunicate:HISLip[:NUMBer]?

Command :SYSTem:COMMunicate:HISLip?

Description The query returns the HiSLIP number used by the Soft Front Panel.

Example Query

:SYST:COMM:HISL?

:SYSTem:COMMunicate:SOCKet[:PORT]?

Command :SYSTem:COMMunicate:SOCKet?

Description The query returns the socket port used by the Soft Front Panel.

Example Query

:SYST:COMM:SOCK?

:SYSTem:COMMunicate:TELNet[:PORT]?

Command :SYSTem:COMMunicate:TELNet?

Description The query returns the telnet port used by the Soft Front Panel.

Example Query

:SYST:COMM:TELN?

:SYSTem:COMMunicate:TCPIp:CONTRol?

Command :SYSTem:COMMunicate:TCPIp:CONTRol?

Description The query returns the port number of the control connection. You can use the control port to send control commands (for example “Device Clear”) to the instrument.

Example Query

:SYST:COMM:TCP:CONT?

`:SYSTem:ERRor:COUNT?`

Command `:SYSTem:ERRor:COUNT?`
 Parameters None
 Description This query returns the error count.
 Examples Query
`:SYST:ERR:COUNT? -> "5"`

`:SYSTem:LICense:LIST?`

Command `:SYSTem:LICense:LIST?`
 Parameters None
 Description This query returns the complete details of the licenses installed.
 Examples Query
`:SYST:LIC:LIST? -> "M8070A-CAL"`

`:SYSTem:LICense:SUBScription:DATE?`

Query `:SYSTem:LICense:SUBScription:DATE? <"FeatureName">`
 Parameters `<"FeatureName">` - License's feature name
 Description This query returns the subscription date of the licenses installed in YYYYMMDD format.
 Examples Query
`:SYST:LIC:SUBS:DATE? "M8070A-CAL"`

Time Base Commands

The TIMEbase subsystem commands control the reference clock source of the DSP.

:TIMEbase:REFClock

Command :TIMEbase:REFClock{INTernal|E100}

Description The command selects the reference clock source.

INTernal Internal 10 MHz reference oscillator (default)

E100 External 100 MHz reference

The following errors are detected, when an external reference clock source is selected:

- Amplitude of external reference signal too small or no signal.
- Frequency of external reference signal out-of-range.

These errors are reported in the STATus subsystem. After selecting a new reference clock source, the status should be queried. In all these error cases the external reference signal is not usable, and the module automatically selects the internal reference oscillator.

Query :TIMEbase:REFClock?

The query returns the currently selected reference clock source.

Returned Format [:TIMEbase:REFClock] {INTernal | E100}<NL>

Instrument Commands

The INSTRUMENT subsystem contains queries to get information like occupied AXIe slot number and M8132A hardware revision. Additionally, commands to update FPGA images and to access FPGA registers are available.

`:INSTRUMENT:SLOT[:NUMBER]?`

Query	<code>:INSTRUMENT:SLOT[:NUMBER]?</code>
Description	The query returns the instrument's slot number in its AXIe frame
Returned Format	<code>[:INSTRUMENT:SLOT[:NUMBER]] {slot_number}<NL></code>

`:INSTRUMENT:IDENTIFY`

Command	<code>:INSTRUMENT:IDENTIFY <seconds></code>
Description	The command identifies the instrument by flashing the green "Access" LED on the front panel for a certain time. <seconds> Optional length of the flashing interval in seconds, default is 10.

`:INSTRUMENT:IDENTIFY:STOP`

Command	<code>:INSTRUMENT:IDENTIFY:STOP</code>
Description	The command stops the flashing of the green "Access" LED before the flashing interval has elapsed.

`:INSTRUMENT:HWREVISION?`

Query	<code>:INSTRUMENT:HWREVISION?</code>
Description	The query returns the instrument's hardware revision number.
Returned Format	<code>[:INSTRUMENT:HWREVISION] {hw_revision}<NL></code>

FPGA Access Commands

NOTE

These commands are used for Option -ED2.

- :INSTRument:FPGA:UPDate
- :INSTRument:FPGA:RESet
- :INSTRument:FPGA:DIRect:DWORDd[?]
- :INSTRument:FPGA:DIRect:BLOCK[?]

:INSTRument:FPGA:UPDate

Command :INSTRument:FPGA:UPDate {A|B}, <filename>

Description The command loads a new image into the FPGA.

A Selects FPGA A for update.

B Selects FPGA B for update.

<file_name> File name of the FPGA update image

:INSTRument:FPGA:RESet

Command :INSTRument:FPGA:RESet {A|B}

Description The command loads the default image into the FPGA.

A Selects FPGA A for update.

B Selects FPGA B for update.

:INSTRument:FPGA:DIRect:DWORd[?]

Command	:INSTRument:FPGA:DIRect:DWORd {A B}, <address>, <value>
Description	The command writes a value at an arbitrary address in the FPGA. A Selects FPGA A for write or read. B Selects FPGA B for write or read. <address> The address in the FPGA. <value> The value to be written at the address in the FPGA.
Query	:INSTRument:FPGA:DIRect:DWORd? {A B}, <address> The query reads a value at an arbitrary address in the FPGA.
Returned Format	[:INSTRument:FPGA:DIRect:DWORd] <value><NL>

:INSTRument:FPGA:DIRect:BLOCK[?]

Command	:INSTRument:FPGA:DIRect:BLOCK {A B}, <address>, <value list>
Description	The command writes a value list at an arbitrary address in the FPGA. A selects FPGA A for write or read. B selects FPGA B for write or read. <address> The address in the FPGA. <value list> a comma separated value list to be written at the address in the FPGA.
Query	:INSTRument:FPGA:DIRect:BLOCK? {A B}, <address>, <number of values> The query reads a list of values at an arbitrary address in the FPGA.
Returned Format	[:INSTRument:FPGA:DIRect:BLOCK] <value list><NL>

:INSTRument:FPGA:GEARbox:CLEar

Command :INSTRument:FPGA:GEARbox:CLEar {A|B}, <channel-mask>

Description The command clears the gearbox for the data path channels in the selected FPGA.

A Selects FPGA A.

B Selects FPGA B.

<channel-mask> The mask selects one or both of the FPGA-internal channels. Bit 0 is used for channel 1, bit 1 for channel 2.

:INSTRument:FPGA:GEARbox:START

Command :INSTRument:FPGA:GEARbox:START {A|B}, <channel-mask>

Description The command starts the gearbox for the data path channels in the selected FPGA.

A Selects FPGA A.

B Selects FPGA B.

<channel-mask> The mask selects one or both of the FPGA-internal channels. Bit 0 is used for channel 1, bit 1 for channel 2.

Current and Power Monitor Commands

:INSTRument:MONitor:CURRent[:TOTal]?

Query :INSTRument:MONitor:CURRent[:TOTal]?

Description The query returns the module's total current.

Returned Format :INSTRument:MONitor:CURRent[:TOTal] <value>

Example :INST:MON:CURR? -> 4.09999990463257E+00

:INSTRument:MONitor:CURRent:MGTAVCC?

Query :INSTRument:MONitor:CURRent:MGTAVCC? {A|B}

Description The query returns the current measured at MGTAVCC in the selected FPGA.

A Selects FPGA A.

B Selects FPGA B.

Returned Format :INSTRument:MONitor:CURRent:MGTAVCC <value>

Example :INST:MON:CURR:MGTAVCC? -> 2.5E+00

:INSTRument:MONitor:CURRent:MGTAVTT?

Query :INSTRument:MONitor:CURRent:MGTAVTT? {A|B}

Description The query returns the current measured at MGTAVTT in the selected FPGA.

A Selects FPGA A.

B Selects FPGA B.

Returned Format :INSTRument:MONitor:CURRent:MGTAVTT <value>

Example :INST:MON:CURR:MGTAVTT? -> 2.0E+00

:INSTRument:MONitor:CURRent:VCCINT?

Query :INSTRument:MONitor:CURRent:VCCINT? {A|B}

Description The query returns the current measured at VCCINT in the selected FPGA.
A Selects FPGA A.
B Selects FPGA B.

Returned Format :INSTRument:MONitor:CURRent:VCCINT <value>

Example :INST:MON:CURR:VCCINT? -> 3.0E+00

:INSTRument:MONitor:POWer[:TOTaL]?

Query :INSTRument:MONitor:POWer[:TOTaL]? {A|B}

Description The query returns the total power consumed by an FPGA, which is the sum of the powers measured at VCCINT, MGTAVCC and MGTAVTT.
A Selects FPGA A.
B Selects FPGA B.

Returned Format :INSTRument:MONitor:POWer[:TOTaL] <value>

Example :INST:MON:POW? -> 7.5E+01

:INSTRument:MONitor:POWer:MGTAVCC?

Query :INSTRument:MONitor:POWer:MGTAVCC? {A|B}

Description The query returns the power measured at MGTAVCC in the selected FPGA.
A Selects FPGA A.
B Selects FPGA B.

Returned Format :INSTRument:MONitor:POWer:MGTAVCC <value>

Example :INST:MON:POW:MGTAVCC? -> 2.5E+01

:INSTRument:MONitor:POWer:MGTAVTT?

Query :INSTRument:MONitor:POWer:MGTAVTT? {A|B}

Description The query returns the power measured at MGTAVTT in the selected FPGA.

A Selects FPGA A.

B Selects FPGA B.

Returned Format :INSTRument:MONitor:POWer:MGTAVTT <value>

Example :INST:MON:POW:MGTAVTT? -> 2.0E+01

:INSTRument:MONitor:POWer:VCCINT?

Query :INSTRument:MONitor:POWer:VCCINT? {A|B}

Description The query returns the power measured at VCCINT in the selected FPGA.

A Selects FPGA A.

B Selects FPGA B.

Returned Format :INSTRument:MONitor:POWer:VCCINT <value>

Example :INST:MON:POW:VCCINT? -> 3.0E+01

Sandbox Commands

`:INSTRument:SANDbox<M>:NAME?`

Query `:INSTRument:SANDbox<M>:NAME?`
 Description The query returns the name of the FPGA sandbox.
 <M> An integer, 1 for FPGA A, 2 for FPGA B
 Returned Format `[:INSTRument:SANDbox<M>:NAME] <name>`
 Example `:INSTRument:SANDbox1:NAME? -> "M8132_A"`

`:INSTRument:SANDbox<M>:FNAME?`

Query `:INSTRument:SANDbox<M>:FNAME?`
 Description The query returns the name of the FPGA hosting the sandbox.
 <M> An integer, 1 for FPGA A, 2 for FPGA B
 Returned Format `[:INSTRument:SANDbox<M>:FNAME] <name>`
 Example `:INSTRument:SANDbox1:FNAME? -> "M8132_A"`

`:INSTRument:SANDbox<M>:FVERsion?`

Query `:INSTRument:SANDbox<M>:FVERsion?`
 Description The query returns the version of the FPGA hosting the sandbox.
 <M> An integer, 1 for FPGA A, 2 for FPGA B
 Returned Format `[:INSTRument:SANDbox<M>:FVERsion] <name>`
 Example `:INSTRument:SANDbox1:FVERsion? -> 3`

:INSTRument:SANDBox<M>:KID?

Query :INSTRument:SANDBox<M>:KID?

Description The query returns the Kernel ID of the FPGA hosting the sandbox.
 <M> An integer, 1 for FPGA A, 2 for FPGA B

Returned Format [:INSTRument:SANDBox<M>:KID] <name>

Example :INSTRument:SANDBox1:KID? ->
 "345eab9a-1d95-5d93-a50d-6a652930f30a"

:INSTRument:SANDBox<M>:SID?

Query :INSTRument:SANDBox<M>:SID?

Description The query returns the Static Region ID of the FPGA hosting the sandbox.
 <M> An integer, 1 for FPGA A, 2 for FPGA B

Returned Format [:INSTRument:SANDBox<M>:SID] <name>

Example :INSTRument:SANDBox1:SID? ->
 "80090200-d718-69d9-b26b-c7c500000003"

:INSTRument:SANDBox<M>:CONFigure

Command :INSTRument:SANDBox<M>:CONFigure <path>

Description The command loads a *.k7z file and configures the sandbox.
 <M> An integer, 1 for FPGA A, 2 for FPGA B
 <path> The path to the *.k7z file

Example INSTRument:SANDBox1:CONFigure "C:\Program Files
 (x86)\Keysight\M8131\Examples\
 M8132A_example_partial_k7z\
 m8132a_fpga_a_sandbox_a_example_design_4_0.k7z"

:INSTRument:SANDBox<M>:RLIST?

Query :INSTRument:SANDBox<M>:RLIST?

Description The query returns the list of all sandbox registers.
 <M> An integer, 1 for FPGA A, 2 for FPGA B

Returned Format [:INSTRument:SANDBox<M>:RLIST] <register_list>

Example :INSTRument:SANDBox1:RLIST? ->
 "Register_Bank_count,Register_Bank_enable_check,Register_Bank_increment,Register_Bank_scratch"

:INSTRument:SANDBox<M>:RINFO?

Query :INSTRument:SANDBox<M>:RINFO? <name>

Description The query returns for a register name address, length, access type.
 <M> An integer, 1 for FPGA A, 2 for FPGA B
 <name> The name of the register.

Returned Format [:INSTRument:SANDBox<M>:RINFO <name>] <address>, <length>, <access_type>

Example :INSTRument:SANDBox1:RINFO? "Register_Bank_scratch"->
 0, 4, "RW"

:INSTRument:SANDBox<M>:PEEK?

Query :INSTRument:SANDBox<M>:PEEK? <address_or_name>

Description The query returns the register value read.
 <M> An integer, 1 for FPGA A, 2 for FPGA B
 <address_or_name> The address or name of the register

Returned Format [:INSTRument:SANDBox<M>:PEEK < address_or_name >] <value>

Example :INSTRument:SANDBox1:PEEK? "Register_Bank_scratch" ->
 7

:INSTRument:SANDBox<M>:POKE

Command :INSTRument:SANDBox<M>:POKE <address_or_name>,<value>

Description The command writes a register value.

<M> An integer, 1 for FPGA A, 2 for FPGA B

<address_or_name> The address or name of the register

<value> The register value

Example :INSTRument:SANDBox1:POKE "Register_Bank_scratch",7

:INSTRument:SANDBox<M>:SREAd?

Query :INSTRument:SANDBox<M>:SREAd? <index>,<size>

Description Not yet supported.

<M> An integer, 1 for FPGA A, 2 for FPGA B

<index> The stream index.

<size> The read size in bytes.

Returned Format [:INSTRument:SANDBox<M>:SREAd < index>,<size>] <binary_block>

Example :INSTRument:SANDBox1:SREAd? ->

:INSTRument:SANDBox<M>:SREAd:BLOCK?

Query :INSTRument:SANDBox<M>:SREAd:BLOCK? <index>,<size>

Description Not yet supported.

<M> An integer, 1 for FPGA A, 2 for FPGA B

<index> The stream index.

<size> The read size in bytes.

Returned Format [:INSTRument:SANDBox<M>:SREAd:BLOCK < index>,<size>] <csv_block>

Example :INSTRument:SANDBox1:SREAd:BLOCK? ->

:INSTRument:SANDbox<M>:SWRite

Command :INSTRument:SANDbox<M>:SWRite <index>,<binary_block>

Description Not yet supported.

<M> An integer, 1 for FPGA A, 2 for FPGA B

<index> The stream index

<binary_block> The data block in binary format

Example :INSTRument:SANDbox1:SWRite

:INSTRument:SANDbox<M>:SWRite:BLOCK

Command :INSTRument:SANDbox<M>:SWRite:BLOCK
<index>,<csv_block>

Description Not yet supported.

<M> An integer, 1 for FPGA A, 2 for FPGA B

<index> The stream index

<csv_block> The data block in CSV format

Example :INSTRument:SANDbox1:SWRite:BLOCK

:INSTRument:SANDbox<M>:MLIST?

Query :INSTRument:SANDbox<M>:MLIST?

Description The query returns the list of all memory names.

<M> An integer, 1 for FPGA A, 2 for FPGA B

Returned format [:INSTRument:SANDbox<M>:MLIST] <memory_map_list>

Example :INSTRument:SANDbox1:MLIST? -> ""

:INSTRUMENT:SANDBOX<M>:MINFO?

Query :INSTRUMENT:SANDBOX<M>:MINFO? <name>

Description The query returns for a memory name address and length.
 <M> An integer, 1 for FPGA A, 2 for FPGA B
 <name> The name of the memory.

Returned format [:INSTRUMENT:SANDBOX<M>:MINFO <name>] <address>,<length>

Example :INSTRUMENT:SANDBOX1:MINFO? "" -> 0,4

:INSTRUMENT:SANDBOX<M>:MREAD?

Query :INSTRUMENT:SANDBOX<M>:MREAD?<address_or_name>,<size>

Description Not yet supported.
 <M> An integer, 1 for FPGA A, 2 for FPGA B
 <address_or_name> The address or name of the memory
 <size> The read size in 4-byte words

Returned format [:INSTRUMENT:SANDBOX<M>:MREAD<address_or_name>,<size>] <binary_block>

Example :INSTRUMENT:SANDBOX1:MREAD?

:INSTRUMENT:SANDBOX<M>:MREAD:BLOCK?

Query :INSTRUMENT:SANDBOX<M>:MREAD:BLOCK?<address_or_name>,<size>

Description Not yet supported.
 <M> An integer, 1 for FPGA A, 2 for FPGA B
 <address_or_name> The address or name of the memory
 <size> The read size in 4-byte words

Returned format [:INSTRUMENT:SANDBOX<M>:MREAD:BLOCK<address_or_name>,<size>] <csv_block>

Example :INSTRUMENT:SANDBOX1:MREAD:BLOCK? ->

`:INSTRument:SANDbox<M>:MWRite`

Command `:INSTRument:SANDbox<M>:MWRite
<address_or_name>,<binary_block>`

Description Not yet supported.
 <M> An integer, 1 for FPGA A, 2 for FPGA B
 <address_or_name> The address or name of the memory
 <binary_block> The data block in binary format

Example `:INSTRument:SANDbox1:MWRite`

`:INSTRument:SANDbox<M>:MWRite:BLOCK`

Command `:INSTRument:SANDbox<M>:MWRite:BLOCK
<address_or_name>,<csv_block>`

Description Not yet supported.
 <M> An integer, 1 for FPGA A, 2 for FPGA B
 <address_or_name> The address or name of the memory
 <csv_block> The data block in CSV format

Example `:INSTRument:SANDbox1:MWRite:BLOCK`

Optical Data Interface Commands

The Optical Data Interface subsystem is used to setup the optical ports of the M8132A.

This product implements a subset of the “Application Programming Interface for Test and Measurement – Optical Data Interface, Revision 2.0”.

The complete specification can be found here:
<http://axiestandard.org/odispecifications.html>

NOTE

When using the M8132A in 10GbE mode, the ODI:ACHannels? returns a maximum of 1,2,3 (instead of 1,2,3,4).

The range of allowable channel suffices on all ODI:PORT and ODI:PRODUCer commands is now reduced:

ODI:PORT{1:3}

ODI:PRODUCer{1:3}

:ODI:ACHannels?

Query :ODI:ACHannels?

Description The query returns the usable optical channels as a string. The channel names are separated by commas.

<N> An integer to select the ODI port, 1-4.

Return Format [:ODI:ACHannels] {active_channels_string}<NL>

:ODI:PORT:COUNT?

Query :ODI:PORT:COUNT?

Description The query returns the total number of ODI channels.

Return Format [:ODI:PORT:COUNT] <ports><NL>

Example :ODI:PORT:COUNT? -> 4

`:ODI:PORT<N>:CAPability:DIRection?`

Query `:ODI:PORT<N>:CAPability:DIRection?`

Description The query returns the list of data transfer directions supported by this port.

Return Format `[:ODI:PORT<N>:CAPability:DIRection]`
`<direction-list><NL>`
`<direction-list>: [BIDirection | PRODucer | CONSUMER |`
`DUDirection] [,...]`

Example `:ODI:PORT:CAP:DIR? -> "CONSUMER, BIDirection"`

`:ODI:PORT<N>:CAPability:FCONtrols?`

Query `:ODI:PORT1:CAPability:FCONtrols?`

Parameters None

Description The query returns the list of flow control types supported by this port.

Return Format `[:ODI:PORT1:CAPability:FCONtrols]`
`<flow-control-list><NL>`
`<flow-control-list>: [NONE | IBAND | IBPChannel |`
`OOBWire | OOBplane<M>] [,...]`
`<M> An integer, 0 - 13`

Example `:ODI:PORT1:CAP:FCON? -> "NONE, IBAND"`

`:ODI:PORT<N>:CAPability:LANes?`

Query `:ODI:PORT<N>:CAPability:LANes?`

Parameters None

Description The query returns the number of lanes supported by this port.

Return Format `[:ODI:PORT<N>:CAPability:LANes] <lanes><NL>`

Example `:ODI:PORT1:CAP:LAN? -> 12`

:ODI:PORT<N>:CAPability:NAME?

Query :ODI:PORT<N>:CAPability:NAME?
 Parameters None
 Description The query returns the name of the port.
 Return Format [:ODI:PORT<N>:CAPability:NAME] <name><NL>
 Example :ODI:PORT:CAP:NAME? -> "ODI1"

:ODI:PORT<N>:CAPability:RATes?

Query :ODI:PORT1:CAPability:RATes?
 Parameters None
 Description The query returns the list of lane rates supported by this port.
 Return Format [:ODI:PORT1:CAPability:RATes] <rate-list><NL>
 <rate-list>: [R125 | R141] [,...]
 Example :ODI:PORT1:CAP:RAT? -> "R141"

:ODI:PORT<N>:CAPability:RBMax?

Query :ODI:PORT<N>:CAPability:RBMax?
 Parameters None
 Description The query returns the supported receiver maximum burst values.
 Return Format [:ODI:PORT<N>:CAPability:RBMax] <burst-max-list><NL>
 <burst-max-list>: [256 | 2048] [,...]
 Example :ODI:PORT:CAP:RBM? -> 2048

:ODI:PORT<N>:CAPability:TBMax?

Query :ODI:PORT<N>:CAPability:TBMax?
 Parameters None
 Description The query returns the supported transmitter maximum burst values.

Return Format `[:ODI:PORT<N>:CAPability:TBMax] <burst-max-list><NL>`
`<burst-max-list> ::= [256 | 2048] [,...]`

Example `ODI:PORT:CAP:TBMax? -> 256,2048`

`:ODI:PORT<N>:CAPability:TRMatch?`

Query `:ODI:PORT:CAPability:TRMatch?`

Parameters None

Description The query returns a Boolean value, indicating if transmission rate matching is supported.

Return Format `[:ODI:PORT:CAPability:TRMatch] <rate-match><NL>`

Example `:ODI:PORT:CAP:TRM? -> 0`

`:ODI:PORT<N>:NAME?`

Query `:ODI:PORT:NAME?`

Parameters None

Description The query returns the name of the port.

Return Format `[:ODI:PORT:NAME] <name><NL>`

Example `:ODI:PORT:NAME? -> "ODI1"`

`:ODI:PORT<N>:ACTivate`

Command `:ODI:PORT<N>:ACTivate <lane_rate>, <tx_burst_max>,
 <directionality>, <tx_flow_control>,
 <rx_flow_control>, <options>`

Description The command switches on the optical port using the specified parameters.

`<N>` An integer to select the ODI port, 1-4.

`<lane_rate>` Lane rate

R141 14.1 Gbit/s.

`<tx_burst_max>` Maximum transmit burst size in bytes. Possible values are 256 and 2048

<directionality> Directionality
 PRODUCER Transmit direction
 CONSUMER Receive direction

 <tx_flow_control> Transmit flow control
 NONE
 IBAND In-band

 <rx_flow_control> Receive flow control
 NONE
 IBAND In-band

 <options> String to pass additional instrument-specific settings. For future expansion. Currently not used.

Query :ODI:PORT<N>:ACTivate?

Description When the port is active, this query returns the parameter values used in the command to activate the port.

:ODI:PORT<N>:DEACTivate

Command :ODI:PORT<N>:DEACTivate

Description The command switches off the optical port.
 <N> An integer to select the ODI port, 1-4.

Example :ODI:PORT1:DEAC

:ODI:PORT<N>:CSTATUS?

Query :ODI:PORT<N>:CSTATUS?

Description The query returns the communication status of an optical port.
 <N> An integer to select the ODI port, 1-4.

Returned Format [:ODI:PORT<N>:CSTATUS] <status><NL>
 <status> 32-bit integer, meaning of the status bits is described in [Table 12](#) on page -100.

Table 12

Name	Bits	Description
Active	0	Port activated by software. Actual readiness to send and receive will depend upon the opposite end of the link and flow control configuration.
TxReady	1	Ready to transmit and flow control allows. If flow control is disabled, transmit will always be ready to send. If flow control is enabled, the port will not be 'ready to send' until receiver is ready and indicating XON via flow control. To troubleshoot TxReady not becoming set in this case, troubleshoot the receive path starting with RxSignalLoss.
RxReady	2	Receiver ready. All lanes synchronized and aligned.
RxLaneError	3	Error in one or more lanes since last GetStatus.
RxBurstMaxError	4	Received too large a burst since last GetStatus.
RxCrcError	5	Received bad burst CRC since last GetStatus.
RxOverrun	6	Receiver data overrun since last GetStatus
RxSignalLoss	7	Received signal loss. Optical power too low.
RxSyncPending	8	Receiver activated but has not achieved synchronization
	9 to 15	Unused
RxFcStatus	16	Received link-level flow control status. 1 is XON, 0 is XOFF. From Interlaken idle/control word bit 55 or from an out-of-band flow control signal.
RxFcStatus0 to RxFcStatus14	17 to 31	Received per-channel flow control status bits. 1 is XON, 0 is XOFF. Bit 17 is channel 0 from bit 54 of the Interlaken idle/control word, bit 18 is channel 1 from bit 53 of the control word, and so on.

Status bits described with "since last GetStatus" are cleared by `:ODI:PORT<N>:CSTATUS?` query. All status bits will be 0 on an inactive port.

:ODI:PORT<N>:PStatistics:BBURsts?

Query :ODI:PORT<N>:PStatistics:BBURsts?
 Parameters None
 Description This query returns the bad burst received by the ODI port.
 Example :ODI:PORT1:PST:BBUR? -> <integer>

:ODI:PORT<N>:PStatistics:RBYTes?

Query :ODI:PORT<N>:PStatistics:RBYTes?
 Parameters None
 Description This query returns the number of bytes received by the ODI port.
 Example :ODI:PORT1:PST:RBYT? -> <integer>

:ODI:PORT<N>:PStatistics:TBYTes?

Query :ODI:PORT<N>:PStatistics:TBYTes?
 Parameters None
 Description This query returns the number of bytes transmitted by the ODI port.
 Example :ODI:PORT1:PST:TBYT? -> <integer>

:ODI:PORT<N>:PStatistics:THOFfs?

Query :ODI:PORT<N>:PStatistics:THOFfs?
 Parameters None
 Description This query returns the transmission holdoffs.
 Example :ODI:PORT1:PST:THOF? -> <integer>

Trigger Commands

:TRIGger:OUTPut:MODE

Command :TRIGger:OUTPut:MODE {A|B},
{LOW|HIGH|TOGGle|FSM|BYPass}

Description The command selects the trigger output mode for the selected FPGA. The mode determines which data the FPGA sends to the trigger output. The :TRIGger:OUTPut:SOURce command finally determines which FPGA's data is displayed at the trigger output.

A Selects FPGA A.

B Selects FPGA B.

LOW Constant low-level

HIGH Constant high-level

TOGGle Low-level/high-level toggle pattern. 200 MHz square wave with 50% duty cycle.

BYPass

The high-speed trigger output of the customer accessible area is fed to the transceiver driving the front panel SMA connector.

The deterministic latency setup procedure uses this mode with the default.

FPGA Bit Files which are loaded at the Soft Front Panel Start-up.

Query :TRIGger:OUTPut:MODE? {A|B}

The query returns the current trigger output mode.

Returned Format [:TRIGger:OUTPut:MODE {A|B}] { LOW|HIGH |TOGGle|FSM|BYPass }<NL>

`:TRIGger:OUTPut:SOURce`

Command	<code>:TRIGger:OUTPut:SOURce {A B}</code>
Description	The command selects, which FPGA's data is displayed at the trigger output. A Selects FPGA A. B Selects FPGA B.
Query	<code>:TRIGger:OUTPut:SOURce?</code> The query returns the current trigger output source.
Returned Format	<code>[:TRIGger:OUTPut:SOURce] {A B }<NL></code>

`:TRIGger:LEVel:EXTernal`

Command	<code>:TRIGger:LEVel:EXTernal <level></code>
Description	The command specifies the trigger level when the external trigger input is used as trigger source. <level> The trigger level in volts as a floating-point number.
Query	<code>:TRIGger:LEVel:EXTernal?</code> The query returns the current trigger level.
Returned Format	<code>[:TRIGger:LEVel:EXTernal] <level><NL></code>

Control In/Out Commands

:CIOut:MUX

Command :CIOut:MUX <Input Mux setting>,<Output Mux setting>

Parameters Two decimal values: the first one represents the 24-bit configuration register of the Input Mux and the second one represents the 21-bit register of the Output Mux.

Table 13 Bit Positions for output ports of the Input Multiplexer

Bit Positions	Output Port
23..20	GP_TRIG_IN_B(2)
19..16	GP_TRIG_IN_B(1)
15..12	GP_TRIG_IN_B(0)
11..8	GP_TRIG_IN_A(2)
7..4	GP_TRIG_IN_A(1)
3..0	GP_TRIG_IN_A(0)

Table 14 Bit Positions for output ports of the Output Multiplexer

Bit Positions	Output Port
20..18	LOOP_BACK (1)
17..15	LOOP_BACK (0)
14..12	Control Out (9)
11..9	Control Out (8)
8..6	Control Out (7)
5..3	Control Out (6)
2..0	Control Out (5)

Description The command sets both multiplexers' registers, except the Clear Bits, which are handled in a separate command. The Reset value in hardware for both registers is 0, meaning:

- Input Mux: Control Input Pin 0 is mapped to all Mux outputs.
- Output Mux: FPGA Trigger Out Pin 0 is mapped to all Mux outputs.

Further mappings are provided in the following tables:

Table 15 Mapping between input and output ports of the Input Multiplexer

Value (binary)	Port
0000	Control In (0)
0001	Control In (1)
0010	Control In (2)
0011	Control In (3)
0100	Control In (4)
0101	Trig In
0110	Reserved, do not use
0111	Reserved, do not use
1000	LOOP_BACK (0)
1001	LOOP_BACK (1)

Table 16 Mapping between input and output ports of the Output Multiplexer

Value (binary)	Port
000	GP_TRIG_OUT_A(0)
001	GP_TRIG_OUT_A(1)
010	GP_TRIG_OUT_A(2)
011	GP_TRIG_OUT_B(0)
100	GP_TRIG_OUT_B(1)
101	GP_TRIG_OUT_B(2)

Query :CIOut:MUX?

Description The query returns two comma separated decimal values, corresponding to the status of configuration register of each multiplexer.

:CIOut:MUX:CLR

Command :CIOut:MUX:CLR {ON|OFF|1|0}, {ON|OFF|1|0}

Description The command sets the Clear Bit of the Input and Output Multiplexers. Two possible values are:

ON | 1: Mux outputs are forced to 0.

OFF | 0 (default): Mux outputs carry signal of the mapped inputs.

Query :CIOut:MUX:CLR?

Description The query returns two comma separated integers (0 or 1), representing the status of the Clear Bit for Input and Output Multiplexers.

:CIOut:OUTPut

Command :CIOut:OUTPut {ON|OFF|1|0}

Description The command enables/disables the control outputs:

ON | 1: Enables control outputs.

OFF | 0 (default): Disables control outputs.

Query :CIOut:OUTPut?

Description The query returns the status of control outputs.

TEST Commands

:TEST:PON?

Query	:TEST:PON?
Parameters	None
Description	This query returns the result of the power on self-tests.
Example	Query :TEST:PON?

:TEST:TST?

Query	:TEST:TST?
Parameters	None
Description	This query is similar to *TST? but the actual test messages are returned.
Example	Query :TEST:TST?

Ethernet Commands

The Ethernet commands are available only when the M8132A is started in 10GbE operation using the command line /M8132TenGbe. These commands do not appear when the M8132A is started in the usual 4 ODI mode of operation.

:ETHernet:PORT[1-8]:[STAtE][?]

Command :ETHernet:PORT[1-8]:[STAtE] {ON|OFF|1|0}

Parameters ON|OFF|1|0

Description The command enables/disables the 10GbE port:

ON | 1: Enables port

OFF | 0 (default): Disables port

Example :ETH:PORT[1] ON

Query :ETHernet:PORT[1-8]:[STAtE]?

Description The query returns the status of the 10GbE port.

Example :ETH:PORT[1]? -> 1

:ETHernet:PORT[1-8]:FRAMe:MACSource:[STAtE][?]

Command :ETHernet:PORT[1-8]:FRAMe:MACSource:[STAtE]
0|1|ON|OFF

Parameters ON|OFF|1|0

Description This command enables/disables override of the source mac address field in transmitted frames.

When disabled, the source MAC address field is transmitted unchanged from the CAA design.

When enabled, the source MAC address field in each transmitted packet will use the value from ETHernet:PORT[1-8]:FRAMe:MACSource:VALue

Default value ON

Example :ETH:PORT[1]:FRAM:MACS OFF

Query :ETHernet:PORT[1-8]:FRAMe:MACSource:[StAte]?

Description This query returns the current state.

Example :ETH:PORT[1]:FRAM:MACS? -> 0

:ETHernet:PORT[1-8]:FRAMe:MACSource:VALue[?]

Command :ETHernet:PORT[1-8]:FRAMe:MACSource:VALue

Parameters Value = Hexadecimal formatted 48 bit source MAC address

Description Set/query the override Source MAC address. This command accepts a numeric parameter, which is decimal by default.

Default value: a unique locally-administered value created from the instrument serial number and ethernet port number of form 82:09:02:xx:xx:xx

To enter a value in hexadecimal, use #H as shown in the example.

Example To set source MAC address to "AA:BB:CC:DD:EE:FF"

:ETH:PORT1:FRAM:MACS:VAL 187723572702975

:ETH:PORT1:FRAM:MACS:VAL? -> 187723572702975

:ETHernet:PORT[1-8]:FRAMe:MACDest:[StAte][?]

Command :ETHernet:PORT[1-8]:FRAMe:MACDest:[StAte] 0|1|ON|OFF

Parameters 0|1|ON|OFF

Description This command enables/disables override of the destination mac address field in transmitted frames.

When disabled, the destination MAC address field is transmitted unchanged from the CAA design.

When enabled, the destination MAC address field in each transmitted packet will use the value from ETHernet:PORT[1-8]:FRAMe:MACDest:VALue

Default value OFF

Example :ETH:PORT[2]:FRAM:MACD ON

:ETH:PORT[2]:FRAM:MACD? -> 1

:ETHernet:PORT[1-8]:FRAMe:MACDest:VALue [?]

Command	:ETHernet:PORT[1-8]:FRAMe:MACDest:VALue #Haabbccddeeff
Parameters	Value = #Haabbccddeeff
Description	Set/query the override Destination MAC address. This command accepts a numeric parameter, which is decimal by default. To enter a value in hexadecimal, use #H, as shown in the example.
Default Value	0
Example	Command To set destination MAC address to "AA:BB:CC:DD:EE:FF" :ETH:PORT1:FRAM:MACD:VAL 187723572702975 Query :ETH:PORT1:FRAM:MACD:VAL? -> 187723572702975

:ETHernet:PORT[1-8]:FRAMe:ETHertype:[STAtE][?]

Command	:ETHernet:PORT[1-8]:FRAMe:ETHertype:[STAtE] 0 1 ON OFF
Parameters	0 1 ON OFF
Description	This command enable/disable override of the Ethernet Type field in transmitted frames. When disabled, the Ethernet Type field is transmitted unchanged from the CAA design. When enabled, the Ethernet Type field in each transmitted packet will use the value from ETHernet:PORT[1-8]:FRAMe:ETHertype:VALue
Default Value	OFF
Example	Command :ETH:PORT[1]:FRAM:ETH ON Query :ETH:PORT[1]:FRAM:ETH? -> 1

:ETHernet:PORT[1-8]:FRAMe:ETHertype:VALue[?]

Command :ETHernet:PORT[1-8]:FRAMe:ETHertype:VALue
 Parameters Numbers or hexadecimal
 Description Set/query the override Ethernet Type field value. This command accepts a numeric parameter, which is decimal by default. To enter a value in hexadecimal, use #H, as shown in the example.
 Default Value 2048
 Example To set Ethernet Type field to 0x800
 :ETH:PORT1:FRAM:ETH:VAL 2048
 Query
 :ETH:PORT1:FRAM:ETH:VAL? -> 2048

:ETHernet:PORT[1-8]:CStatus?

Query :ETHernet:PORT[1-8]:CStatus?
 Parameters None
 Description This query returns the status of the port. Status bits are latched between reads. All bits are reset when the port is enabled. A value of 0 is expected during error-free normal operation.
 Bit0: Optical LOS
 Bit1: !STAT_RX_VALID_CTRL_CODE
 Bit2: !STAT_RX_BLOCK_LOCK_REG
 Bit3: Unused
 Bit4: STAT_RX_HI_BER
 Bit5: STAT_RX_REMOTE_FAULT
 Bit6: STAT_RX_LOCAL_FAULT
 Bit7: STAT_RX_INTERNAL_LOCAL_FAULT
 Bit8: STAT_RX_RECEIVED_LOCAL_FAULT

```

Bit9: STAT_RX_BAD_PREAMBLE"
Bit10: STAT_RX_BAD_SFD
Bit11: STAT_RX_GOT_SIGNAL_OS
Bit12: STAT_TX_LOCAL_FAULT
Bit13: STAT_TX_FRAMING_ERROR
Bits 14-15: Unused
Bit16: STAT_TXUNFOUT

```

:ETHERnet:PORT[1-8]:PSTatistics[:RX]:GOOD?

Query :ETHERnet:PORT[1-8]:PSTatistics[:RX]:GOOD?

Description This query returns the number of received good packets. The packet-count is reset to 0 when the port is enabled.

Example :ETH:PORT[1]:PST:GOOD?

:ETHERnet:PORT[1-8]:PSTatistics[:RX]:BAD?

Query :ETHERnet:PORT[1-8]:PSTatistics[:RX]:BAD?

Description This query returns the number of received bad packets. The packet-count is reset to 0 when the port is enabled.

(Bad packets are calculated as the difference between total packets and good packets)

Example :ETH:PORT[1]:PST:BAD?

:ETHERnet:PORT[1-8]:PSTatistics[:RX]:DROPPed?

Query :ETHERnet:PORT[1-8]:PSTatistics[:RX]:DROPPed?

Description This query returns the number of received dropped packets. The packet-count is reset to 0 when the port is enabled.

(Dropped packets are calculated as the sum of undersize, oversize and packets with bad FCS)

Example :ETH:PORT[1]:PST:DROP?

:ETHernet:PORT[1-8]:PSTatistics[:RX]:BYTes?

Query :ETHernet:PORT[1-8]:PSTatistics[:RX]:BYTes?
 Description This query returns the number of received bytes. The byte count is reset to 0 when the port is enabled.
 Example :ETH:PORT[1]:PST:BYT?

:ETHernet:PORT[1-8]:PSTatistics:TX:BYTes?

Query :ETHernet:PORT[1-8]:PSTatistics:TX:BYTes?
 Description This query returns the number of transmitted bytes. The byte count is reset to 0 when the port is enabled.
 Example :ETH:PORT[1]:PST:TX:BYT?

:ETHernet:PORT[1-8]:PSTatistics:ALL?

Query :ETHernet:PORT[1-8]:PSTatistics:ALL?
 Description This query returns a single string result containing comma-separated results "TxBytes, RxBytes, RxGood, RxBad, RxDropped, timestamp."
 The timestamp is in units of seconds
 All counts and timestamps are set to 0 when the port is enabled.
 Example :ETH:PORT[1]:PST:ALL? -> "0,0,0,0,0,743.759755296"

7 Examples

[Introduction](#) / 116

[PathwaveCapture](#) / 117

[PathwaveLoopThrough](#) / 118

[PathwaveDpu2Dpu](#) / 120

[PathwaveEthernet](#) / 121

[Continuous Streaming with Deterministic Latency to DSP Module](#) / 122

Introduction

In a standard installation, the examples can be found in the folder “C:\Program Files (x86)\Keysight\M8131\Examples”. They are all console applications and are provided as Microsoft Visual Studio 2019 solutions.

PathwaveCaptureExample example is written in C# and uses the VISA.NET library to control the instrument over SCPI.

The PathwaveLoopThrough example is written in C++ and uses the M8131PublicAPI library to control the Pathwave functionality.

PathwaveCapture

This example program (PathwaveCapture.sln) demonstrates how to load an example Pathwave FPGA build into an M8132A Dsp and set it up for capturing a test pattern generated internally using SCPI commands

The program sets up a passthrough path for channels 1 and 3; channel 1 received data is re-transmitted on channel 3, channel 3 received data is re-transmitted on channel 1.

A data transmit source is configured on channels 2 and 4, and capture is configured on channel 1.

Data captured is then verified and displayed.

Cabling of DSP Connectors

- Connect ODI 1 to ODI 2
- Connect ODI 3 to ODI 4

Setup DSP

Before starting the example program, start the M8132A Soft Front Panel and note the HSLIP address provided for the instrument.

NOTE

The data encoded in RegisterDefinitions.cs file will be replaced by register meta-data from the k7z file in a release shortly.

Usage

PathwaveCaptureExample

```
<dsp hslip addr> <imageFpgaA.k7z> <imageFpgaB.k7z>
```

PathwaveLoopThrough

This example program (PathwaveLoopThrough.slh) demonstrates how to load an example Pathwave FPGA build into an M8132A Dsp using the C++ Public API. For example, with ports 1 and 3 configured for transmit & receive, the program can set up a passthrough path for channels 2 and 4; data sent on port 1 is received on port 2 and re-transmitted on port 4, for the reception on port 3. In the reverse direction simultaneously, data sent on port 3 to port 4 is forwarded through port 2 for the reception on port 1. Received data is re-transmitted on channel 1. A data transmit source is configured on channels 2 and 4. The multiplexer can be configured through program arguments to resize (combine or split) packets as they pass through. The program will verify that the expected number of packets are received.

The other cases are loop-back rather than pass-through. With ports 2 and/or 4 chosen as transceiver sources, the corresponding ports 1 and 3 will perform a simple loopback.

When the Soft Front Panel is configured for 10G ethernet, Port 4 is unavailable, and the `m8132a_fpga_a_sandbox_b_template_design_4_2.k7z` image for fpga A must be used instead of the normal `m8132a_fpga_a_sandbox_a_template_design_4_2.k7z` image. Fpga B image used is `m8132a_fpga_b_sandbox_b_template_design_4_2.k7z` in both cases.

Cabling of DSP Connectors

- Connect ODI 1 to ODI 2
- Connect ODI 3 to ODI 4

Usage

```
PathwaveLoopThrough <dsp hslip addr> <Transceiver Ports>
<imageFpgaA.k7z> <imageFpgaB.k7z> [ <optional param = value> ]
```

Transceiver Ports is a comma-separated list of the ports used to transmit and receive, for example "1,3" for the loop-through case. The corresponding multiplexors (for this example 2 and 4) are configured automatically.

Optional Parameters

Optional parameters and their default values are as follows:

- packetCount=4456448
Number of packets to transmit.
- packetLength=500
Length of transmit packet, in units of 32 bytes, must be even for resize tests.
- packetStartGap=640
Packet start period in 400MHz clock ticks
- resizeEnable=0
Enable resize test mode
- resizePacketLength=1000
New packet size created by loopback/passthrough path, in units of 64 bytes
- useFifoDepthSync=0
Value to set to use_fifo_depth_sync bit in DPU_MUX_CONTROL
- useSync=0
Value to set to use_sync bit in DPU_MUX_CONTROL

PathwaveDpu2Dpu

The Pathwave Dpu2Dpu example in C:\Program Files (x86)\Keysight\M8131\Examples\PathwaveDpu2Dpu gives an example of driving the FPGA Example/Test code exercising the AXI4S interface between the two DPUs.

Cabling of DSP Connectors

This test exercises the internal connections between DPUs and has no external cabling requirements.

Setup DSP

Before starting the example program, start the M8132A Soft Front Panel and note the HSLIP address provided for the instrument.

NOTE

The data encoded in PathwaveDpu2DpuExampleRegisters.h file will be replaced by register meta-data from the k7z file in a release shortly.

Usage

The example uses the m8132a_fpga_a_sandbox_b_template_design_4_2.k7z and m8132a_fpga_b_sandbox_b_template_design_4_2.k7z images found in the C:\Program Files (x86)\Keysight\M8131\Examples\M8132A_example_partial_k7z directory, by default.

Run the example using the command, passing the instrument Soft Front Panel hislip address:

```
PathwaveDpu2Dpu TCPIP0::localhost::hislip0::INSTR
```

The test configures and runs a 2-minute test exercising DPU to DPU links between the two FPGA Customer Accessible Areas and should report 'no problems' for each of the 4 test entities.

PathwaveEthernet

This example program (PathwaveEthernet.sln) demonstrates how to load an example Pathwave FPGA build into an M8132A Dsp and set it up to generate and receive ethernet frames over 10 GbE ports using the C++ Public API. In this example, the ODI4 port is configured as eight independent 10 GbE ports. By default, the program generates traffic on each port, which is expected to be looped back to the same port's receiver. The program will verify that the expected number, size, and payload contents of packets are received. The PathwaveEthernet example is written in C++ and uses the M8131PublicAPI library to control the Pathwave functionality.

Cabling of DSP Connectors

- Connect the Optical Loopback Adapter to ODI 4
- ODI 1, ODI 2, and ODI 3 are unused in this example

Setup DSP

Before starting the example program, start the M8132A Soft Front Panel in 10 GbE mode with the /M8132TenGbe command line switch and note the HSLIP address provided for the instrument.

Usage

```
PathwaveEthernet <dsp hslip addr> <imageFpgaA.k7z>
```

Continuous Streaming with Deterministic Latency to DSP Module

Refer to *Keysight M8131A 16/32 GSa/s Digitizer User's Guide*. The User's Guide of the M8131A includes a description of this example.

8 Characteristics

Performance Specification / 123

Operating Environment / 123

General / 124

Performance Specification

The performance specification can be found in the Data Sheet of the M8132A at: <http://www.keysight.com/find/M8132A>.

Operating Environment

Storage Temperature	-40 °C to +70 °C
Operating Temperature	0 °C to 40 °C
Operating Humidity	5% to 80% relative humidity, non-condensing
Operating Altitude	Up to 2000 m
Installation	Category II
Pollution	Degree 2

WARNING

The instrument is not designed for outdoor use. Do not expose the instrument to rain or other excessive moisture. Protect the instrument from humidity and temperature changes, which could cause condensation within the instrument.

Do not operate the instrument in the presence of flammable gases, fumes or powders. Operation of any electrical instrument in such an environment constitutes a definite safety hazard.

General

Power consumption	280 W (nom)
Safety tested according to	IEC61010-1, ANSI/UL61010, CSA22.2 No. 61010-1 certified
EMC tested according to	IEC61326
Warm-up time	15 min
Calibration interval	N/A
Cooling Requirements	When operating the M8132A choose a location that provides at least 80 mm of clearance at rear, and at least 30 mm of clearance at each side for the AXle chassis.

Index

A

Additional Documents, [21](#)

C

Characteristics, [123](#)
Clock Tab, [38](#)
Common Commands, [72](#)
Connect to Instrument dialog, [26](#)

D

Document Library, [20](#)

E

Errors List Window, [36](#)
Examples, [123](#)

F

File menu, [33](#)

H

Help menu, [35](#)

I

Instrument Commands, [81](#)
IOs Tab, [39](#)

K

Key Features, [17](#)

M

M8132A Digital Signal Processor, [17](#)
M8132A Overview, [17](#)
Mass Memory Commands, [75](#)
Menu bar, [33](#)

O

Operating Environment, [123](#)
Optical Data Interface Commands, [95](#)

P

Performance Specification, [123](#)

R

Related Documents, [20](#)
Remote Programming, [61](#), [62](#)
Root Level Commands, [75](#)

S

Safety Summary, [3](#)
Status bar, [37](#)
Status Commands, [64](#)
System Commands, [75](#)
System Monitor Tab, [51](#)

T

TEST Commands, [107](#)
Time Base Commands, [80](#)
Title bar, [33](#)
Tools menu, [34](#)

U

Utilities menu, [34](#)

V

View menu, [34](#)

This information is subject to
change without notice.
© Keysight Technologies 2021
Edition 2.4, November 2021



M8132-91010

www.keysight.com

