

# Methods and Instruments for Phase Noise Measurement

# Table of Contents

Introduction ..... 3

What is Phase Noise? ..... 4

Methods for Measuring Phase Noise ..... 5

Keysight Instruments and Applications for Phase Noise ..... 11

Conclusion ..... 17

FAQ ..... 18

# Introduction

Phase noise is a critical parameter in electronic systems, affecting the performance of communication devices, radar systems, and precision oscillators. Understanding phase noise and accurately measuring it are essential for designing reliable and high-performance systems. In this article, we delve into various methods for measuring phase noise and explore into the instruments commonly used for this purpose.

We'll discuss the theoretical foundations, practical considerations, and advantages and disadvantages of each method. Additionally, we'll introduce typical instruments employed in phase noise testing.

# What is Phase Noise?

Phase noise is the random fluctuation in the phase or frequency of an oscillating signal caused by the internal noise of the frequency source. It encompasses all factors that contribute to the instability of the output frequency of the frequency source over short-time intervals. Phase noise is a measure of the sideband spectral noise of the frequency signal and directly reflects the short-term stability of the frequency source. In the time domain, phase noise manifests as jitter at the zero-crossing points of the waveform. In the frequency domain, phase noise appears as sidebands of the carrier.

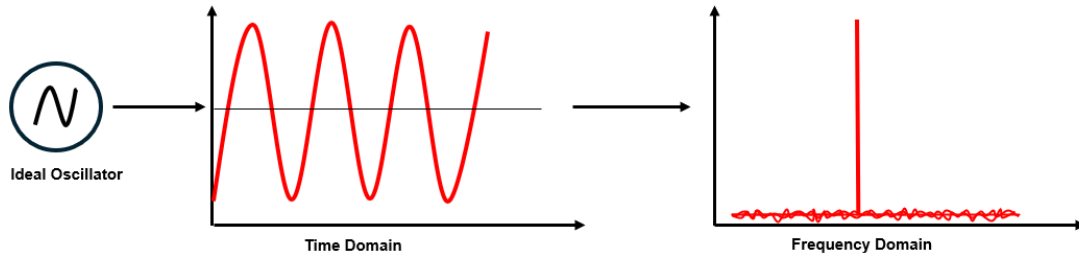

**Figure 1.** An ideal oscillator generates energy only at a specific frequency

A sine wave with amplitude and frequency fluctuations can be expressed as:

$$V(t) = [V_0 + a(t)] \sin[2\pi f_0 t + \varphi(t)]$$

Where:

$a(t)$  is instantaneous amplitude variation

$\varphi(t)$  is instantaneous phase variation

A non-ideal sinusoidal wave will produce multiple spectral components in the frequency domain.

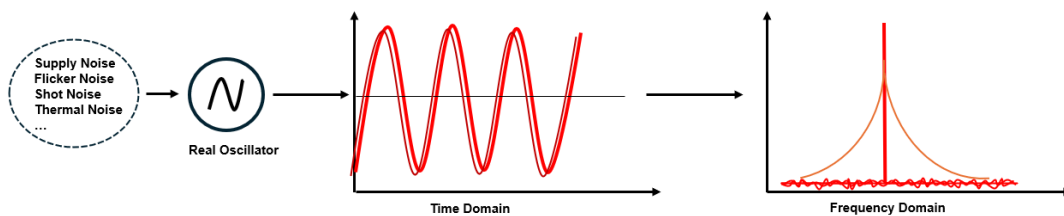

**Figure 2.** A real oscillator spreads energy around the expected frequency

In most cases, the effects of phase variations are much larger and more significant than those of amplitude variations. Phase noise is defined as the ratio of the power per Hz bandwidth at an offset frequency from the carrier to the carrier power. Phase noise sidebands are usually symmetrical around the carrier, with the same phase noise at positive or negative offsets. Therefore, phase noise is typically measured on only one side of the carrier, known as single-sideband (SSB) phase noise, with the upper sideband (positive offsets) used by convention.

The formula for calculating single-sideband phase noise is:  $\mathcal{L}(f_{off}) = P_n(\text{dBm/Hz}) - P_c(\text{dBm})$

Where:

$\mathcal{L}(f_{off})$  is the single-sideband phase noise at an offset frequency  $f_{off}$

$P_n$  is the single-sideband power at the offset frequency ( $f_{off}$ ) in a 1 Hz bandwidth

$P_c$  is the carrier power

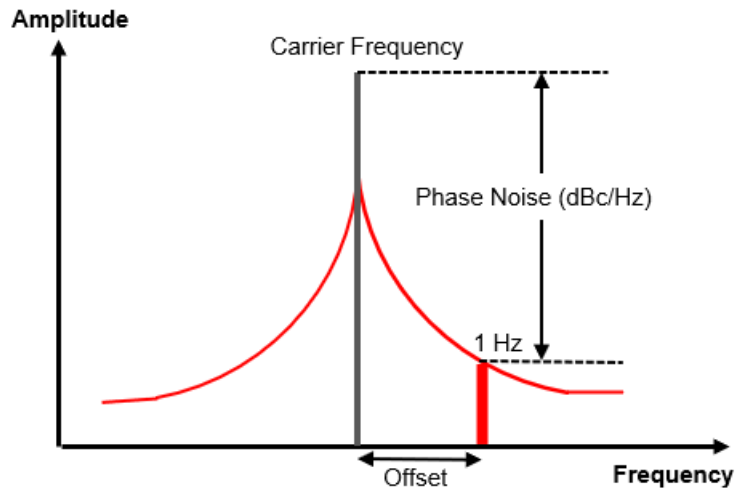

Figure 3. Single-sideband phase noise

## Methods for Measuring Phase Noise

Currently, there are various methods for measuring phase noise, primarily classified based on the phase information extraction circuits used. These methods include direct spectrum analyzer measurement, phase detection, frequency detection, and cross-correlation methods. Different measurement techniques employ different phase information extraction methods, and the performance of the phase extraction circuit directly determines the phase noise measurement performance, such as analysis bandwidth and frequency resolution.

### Direct spectrum analyzer method

Measuring phase noise using a spectrum analyzer is a straightforward and widely used method that is highly effective. Its notable characteristics include simplicity, convenience, and ease of operation. However, the spectrum analyzer used must have high sensitivity, meaning its inherent noise floor must be sufficiently low. The phase noise being measured must be greater than the internal noise of the spectrum analyzer, otherwise accurate measurement cannot be achieved.

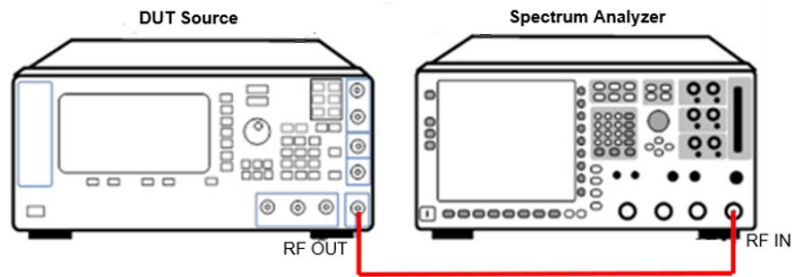

**Figure 4.** Direct spectrum analyzer measure method

The principle of measuring phase noise using the direct spectrum analyzer method is that when the signal under test enters the spectrum analyzer, it is mixed with the Local Oscillator (LO) to produce an Intermediate Frequency (IF). The IF signal is then filtered by an intermediate frequency filter to extract signal characteristics within a certain bandwidth. The noise power measured within a 1 Hz bandwidth at a specific frequency offset from the carrier, compared to the carrier signal power, represents the single-sideband phase noise. Although this method is simple and easy to implement, also have some challenges/limitations

### **Dynamic range**

The dynamic range of a spectrum analyzer characterizes its measurement range. The lower limit is determined by the thermal noise and phase noise of the spectrum analyzer, while the upper limit is determined by the 1 dB compression point of the internal mixer. When using direct spectrum analyzer measure method, we must measure a high-power carrier and measure low noise powers at different offsets, so dynamic range of the spectrum analyzer is therefore very important, maximizing the dynamic range of the spectrum analyzer enhances the phase noise measurement range. When measuring large frequency offset phase noise, the DANL performance of the analyzer dominates over its phase noise performance.

### **Instrument phase noise**

Spectrum analyzer contains multiple local oscillators. Each oscillator will add certain amount of phase noise to DUT signal and it's difficult to separate DUT phase noise from spectrum analyzer phase noise. So, if we use direct spectrum analyzer measure method, the spectrum analyzer's phase noise specification should be at least 10 dB better than DUT.

### **Close-in phase noise and drifting sources**

"Close-in phase noise" means the phase noise that occurs at small frequency offsets from the carrier signal, typically within a range of 1 Hz to 100 Hz. It's difficult to measure because very narrow RBW needed to avoid measuring carrier power and to select only the noise power.

Due to frequency drift of the signal during the sweep cycle of the spectrum analyzer, if the sweep time is too long, excessive frequency drift will occur, leading to measurement errors. Therefore, the sweep time of the spectrum analyzer should be minimized as much as possible. The sweep time of the spectrum analyzer is limited by the sweep range and the Intermediate Frequency (IF) filter response time, resulting

in a lower limit. The response time is related to the bandwidth, the narrower the bandwidth, the longer the response time. Thus, the minimum sweep time is related to the sweep span and the resolution bandwidth settings as follows:

$$\text{Sweep Time} = K \cdot \frac{\text{SPAN}}{\text{RBW}^2}$$

Where:

SPAN is Sweep Width of the Spectrum Analyzer

RBW is Resolution Bandwidth of the Spectrum Analyzer

K is Constant Value, which is a factor related to the intermediate frequency filter of the spectrum analyzer

Therefore, the SPAN should not be set too large, it should only cover the frequency range where the phase noise is measured. The resolution bandwidth (RBW) of the spectrum analyzer should not be set too small, as a smaller RBW results in longer sweep times, which can cause frequency drift of the carrier signal. However, the RBW should not be too large either, as it determines the ability to suppress the carrier level at an offset frequency. If the RBW is too large, it will reduce the sensitivity of the spectrum analyzer, leading to phase noise measurement errors. In practice, an effective method to address the RBW setting issue is to initially select a larger RBW, then gradually reduce the RBW until the measured phase noise value no longer decreases. This RBW setting ensures both the accuracy of phase noise measurement and the minimization of sweep time.

## Reference source/phase-locked loop method

This method uses a double-balanced mixer as a phase detector, with the signal under test applied to the RF port of the phase detector and another high-stability reference signal of the same frequency applied to the LO port. The phase difference between the two signals input to the phase detector is measured. The phase detector outputs a voltage signal that is proportional to the phase difference between the test signal and the reference signal. This voltage signal is then passed through a low-pass filter and a low-noise amplifier before being input to a spectrum analyzer to measure its power spectrum. After calibration and correction, the single-sideband phase noise of the test signal is calculated. The measurement system structure is shown in the below figure.

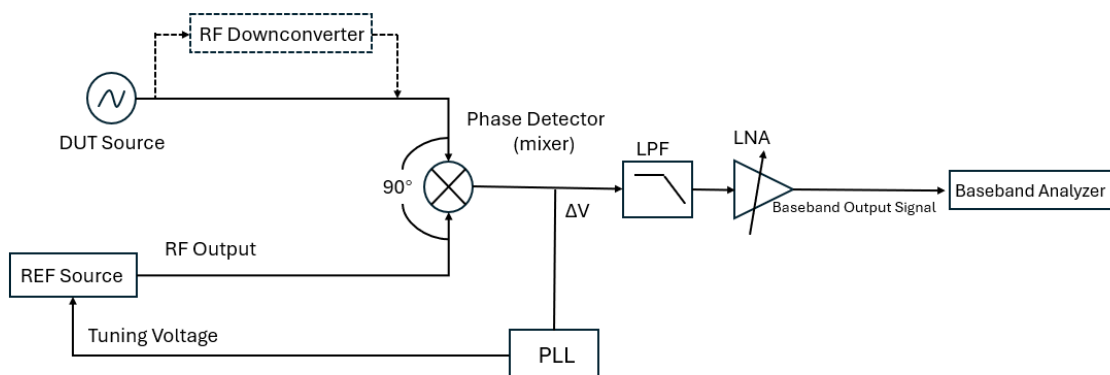

**Figure 5.** Principle of the reference source/phase-locked loop method

There are two sources used, one source is the DUT, the second source is a reference source that the DUT is compared to. Assume that the output of the test signal and the reference source signal are:

$$V_T(t) = V_T \cdot \cos[\omega_T \cdot t + \phi_T(t)]$$

$$V_R(t) = V_R \cdot \cos[\omega_R \cdot t + \phi_R(t)]$$

The mixer output voltage is the product of the test signal and the reference signal:

$$V_1(t) = V_T(t) \cdot V_R(t) \\ = \frac{1}{2} \cdot V_R \cdot V_T \cdot \cos[(\omega_R - \omega_T) \cdot t + \phi_R(t) - \phi_T(t)] + \frac{1}{2} \cdot V_R \cdot V_T \cdot \cos[(\omega_R + \omega_T) \cdot t + \phi_R(t) + \phi_T(t)]$$

After passing through a low-pass filter (assuming the passband gain is a constant 1) to filter out the sum frequency components, can be expressed as:

$$V(t) = \frac{1}{2} \cdot V_R \cdot V_T \cdot \cos[(\omega_R - \omega_T) \cdot t + \phi_R(t) - \phi_T(t)]$$

The reference source is controlled such that it follows the DUT at the same frequency, so  $\omega_R$  equal to  $\omega_T$ , so:

$$V(t) = \frac{1}{2} \cdot V_R \cdot V_T \cdot \cos[(\phi_R(t) - \phi_T(t))]$$

The phase of the reference signal is orthogonal to the DUT signal, so:

$$\phi_R(t) - \phi_T(t) = (2N + 1) \cdot \frac{\pi}{2} + \Delta\phi(t)$$

The final formula can be simplified to:

$$V(t) = K_\phi \cdot \sin[\Delta\phi(t)]$$

For noise, it is generally assumed that  $\Delta\phi(t) \ll 1$  rad, then:

$$V(t) = K_\phi \cdot \Delta\phi(t)$$

Note. The phase noise of the reference must be negligible when compared to the DUT.

This test method has many advantages, like it offers the best sensitivity and widest offset coverage and insensitive to AM and can track the frequency drift of DUT. It also has some limitations, the noise measurement results will be limited by the phase-locked loop, if the power of the test signal generator or the reference source is too low, it will increase the noise floor of the phase detector or cause the phase detector not to work. This issue can be resolved by introducing a low-noise amplifier at the front end of the phase detector, but the noise of the amplifier will also increase the output noise. The measurement sensitivity will be limited by the phase noise of the reference source itself.

## Frequency discrimination method

Frequency discriminator method, also known as the passive method, converts the frequency fluctuations of the source under test into voltage fluctuations. These voltage fluctuations are then measured using a spectrum analyzer to determine phase noise. Common frequency discriminators include delay line/mixer discriminators, RF bridge/delay line discriminators, cavity discriminators, and dual delay line discriminators. Each type of discriminator has its own advantages and disadvantages. This section

introduces the delay line/mixer discriminator, and the principle of measuring phase noise using this method is as below.

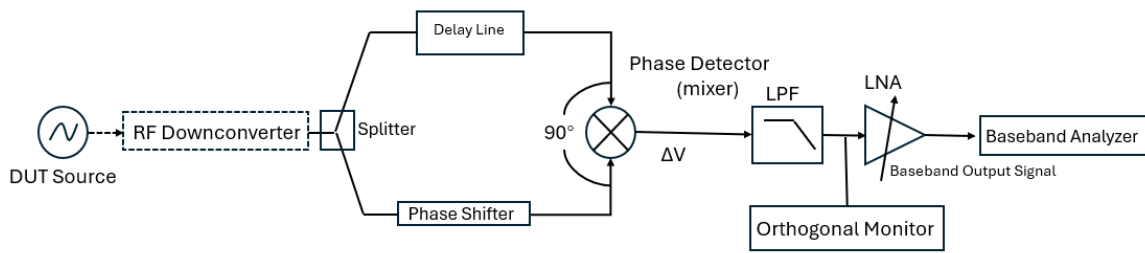

**Figure 6.** Principle of frequency discriminator method

The signal under test is split into two paths by a power splitter. One path passes through a broadband delay line with a delay of  $\tau$ , producing a fixed phase shift of  $\phi = 2\pi f_0 \tau$ . The frequency fluctuation  $\Delta f$  of the source under test is converted into a phase fluctuation  $\Delta\phi = 2\pi\Delta f\tau$  by the delay line and then enters the phase detector. The other path passes through a broadband variable phase shifter before entering the phase detector. The two signals undergo quadrature phase detection, where the phase detector converts the phase fluctuation of the signal under test into noise voltage. After passing through a low-pass filter and a low-noise amplifier, the power spectrum of the noise voltage signal is measured using a spectrum analyzer, from which the relative single-sideband phase noise of the signal under test can be obtained.

The background noise of this measurement method is limited by the length of the delay line and the maximum frequency deviation. Increasing the length of the delay line can improve the background noise, but it will reduce the power reaching the phase detector. Similar to the reference source/phase-locked loop method, if the DUT output power does not compensate for the signal splitting or delay line loss, the power at the phase detector will be insufficient for operation. The advantage of this measurement method is that it only requires one DUT as the signal source, the sensitivity is sufficient for VCO testing, and the noise is relatively low far from the carrier.

## Cross-correlation method

The cross-correlation method is an improved technique based on the phase detection method. Sensitivity is a crucial key indicator for phase noise measurement systems. The cross-correlation method measures the signal under test and the same reference signal source through two independent phase detection measurement channels. The voltage signals containing phase noise information obtained from the two measurement channels are then correlated and their power spectrum is estimated, thereby calculating the single-sideband phase noise of the signal under test. Through correlation, the additional noise from the two independent measurement channels can be largely eliminated, reducing the noise floor of the measurement system and improving important indicators such as sensitivity. The principle block diagram of the cross-correlation method is shown below.

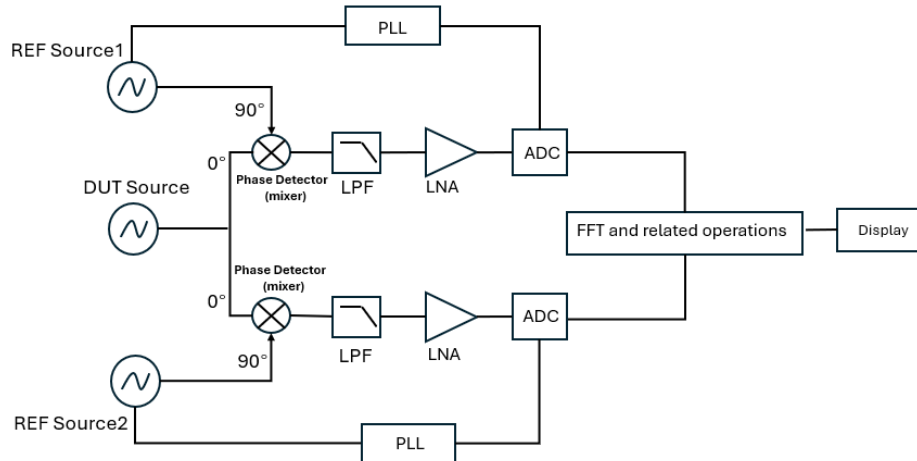

**Figure 7.** Principle of cross-correlation method

This approach uses two duplicate reference-source/PLL channels and calculates the cross-correlation between the two resulting outputs. As shown in Figure 7, the DUT signal under test is split into two paths, each passing through a phase-locked loop and mixed with two independent “identical” local oscillators. After A/D conversion and Fourier transformation, the output signals undergo cross-correlation digital signal processing. Cross-correlation through vector averaging can eliminate the influence of uncorrelated signals from the two paths, thereby suppressing the noise of the built-in reference signal and related circuits, reducing the system's noise floor and relatively enhancing the DUT's noise signal. The degree of noise suppression of the built-in signal source depends on the number of correlations. By changing the number of correlations, the test sensitivity can be improved by up to 20 dB. The larger the correlation setting, the lower the equivalent local noise, but the longer the measurement time.

## Comparison of measurement methods

| Measurement Method                        | Advantages   | Limitations   |
|---|--|---|
| Direct Spectrum Analyzer Method           | <ul style="list-style-type: none"> <li>a. Easy Operation</li> <li>b. Perform a quick measurement on the signal under test</li> </ul>   | <ul style="list-style-type: none"> <li>a. Not good at measuring the phase noise near the carrier</li> <li>b. Not good at measuring drifting signal</li> <li>c. Measurement includes AM noise</li> </ul> |
| Reference Source/Phase-Locked Loop Method | <ul style="list-style-type: none"> <li>a. Wide dynamic range</li> <li>b. Can measure extremely low phase noise near the carrier</li> </ul>   | <ul style="list-style-type: none"> <li>a. Test sensitivity is affected by the reference source</li> <li>b. Setting up the platform and calibration is relatively complex</li> </ul>                     |
| Frequency Discrimination Method           | <ul style="list-style-type: none"> <li>a. Can measure extremely low noise at the far end of the carrier</li> <li>b. Suitable for YIG and other oscillators</li> </ul>                                  | <ul style="list-style-type: none"> <li>a. Not good at measuring the phase noise near the carrier</li> <li>b. Setting up the platform and calibration is relatively complex</li> </ul>                   |
| Cross-correlation Method                  | <ul style="list-style-type: none"> <li>a. Easy Operation</li> <li>b. Can measure extremely low signals over a wide range</li> <li>c. Cross-correlation improves the measurement sensitivity</li> </ul> | <ul style="list-style-type: none"> <li>a. Increasing the number of correlations will increase the measurement time</li> </ul>   |

**Figure 8.** Phase noise measurement method compare

# Keysight Instruments and Applications for Phase Noise

Keysight offers a wide range of comprehensive phase noise measurement solutions, include spectrum analyzers (such as PXA, UXA, MXA, EXA), Signal source analyzer (such as E5052B, E5055/6/7/8A), and PC-based modular systems (such as E5500 series/N5511A phase noise measurement systems). They have different functionality, flexibility, and performance to meet different test requirements.



**Figure 9.** Keysight spectrum analyzers (signal analyzers)

Keysight spectrum analyzers have dedicated phase noise measurement options that automate the measurement process and provide greater measurement accuracy, for example, Keysight’s N9068EM0E phase noise measurement application for the UXA (Pro grade, XA7-class), PXA (Expert grade, XA5-class), MXA (Essential grade, XA3-class), EXA (Essential grade, XA1-class), and CXA (Essential grade, XA1-class) X-Series signal analyzers uses the direct spectrum method.

The application automatically configures and optimizes the analyzer’s settings, such as resolution bandwidth (RBW) and phase locked loops to achieve the highest measurement accuracy and speed. The Log Plot measurement measures the single-sideband phase noise (in dBc/Hz) versus offset frequencies and the results are shown in logarithmic scale. This allows you to view the phase noise behavior of the signal under test across many decades of offset frequencies. Noise Floor Extensions (NFE) and overdrive in the Phase Noise Application can give a dramatic improvement in the measurement floor for wide-offset phase noise.

Besides, to improve the phase noise measurement can use Noise Cancel function, noise cancellation is a process where a reference trace is “subtracted” from a log plot measurement trace, providing more accurate results. The reference trace can be of the internal DANL floor of the analyzer, or a log plot trace of a known lower phase noise source for comparison. You can use a known low phase noise source to create a reference trace. The phase noise of this source should be much better than the signal analyzer’s phase noise, then the result trace will represent the signal analyzer’s internal phase noise. A reference trace from a good source that is relatively free of phase noise will let you compensate for the phase noise of the analyzer. The phase noise results after noise cancellation should look like the figure below. The purple trace shows the reference trace used for noise cancellation.

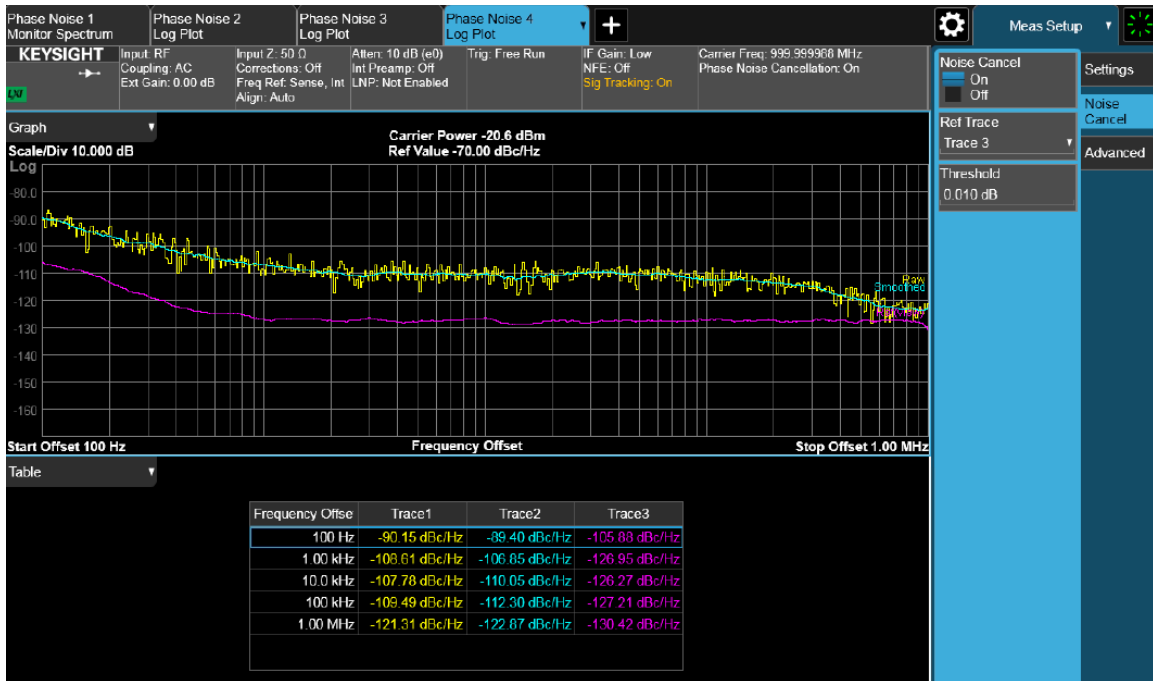

Figure 10. Phase noise measurement with spectrum analyzers (signal analyzers)

The Signal Source Analyzer (SSA) is designed to help R&D and manufacturing engineers across a wide range of electronic industries perform signal source tests more accurately, at higher throughput and lower cost, with unprecedented simplicity. It used cross-correlation method. The SSA-X has two uncorrelated internal LO sources with low phase noise, and it has two input ports, each port has two uncorrelated receivers. Cross Correlation (XCORR) is used to improve phase noise measurement sensitivity. The SSA-X all-in-one architecture simplifies complex test setups while enabling comprehensive signal source and device characterization.



Figure 11. Keysight SSA-X Series, part of the PN7-class of Keysight Phase Noise Analyzers

Users can increase the cross-correlation factor to improve the sensitivity. With the S96301xB SSA-X signal source analyzer advanced feature application can enable the cross correlation 100000 times at most, and it will allow the sensitivity improvement by 25 dB at maximum. And the SSA-X phase noise measurement offset frequency range can reach 1 mHz to 1 GHz, the maximum offset frequency can be extended to 3 GHz for  $150 \text{ MHz} \leq \text{carrier} < 54 \text{ GHz}$  with the offset extension mode.

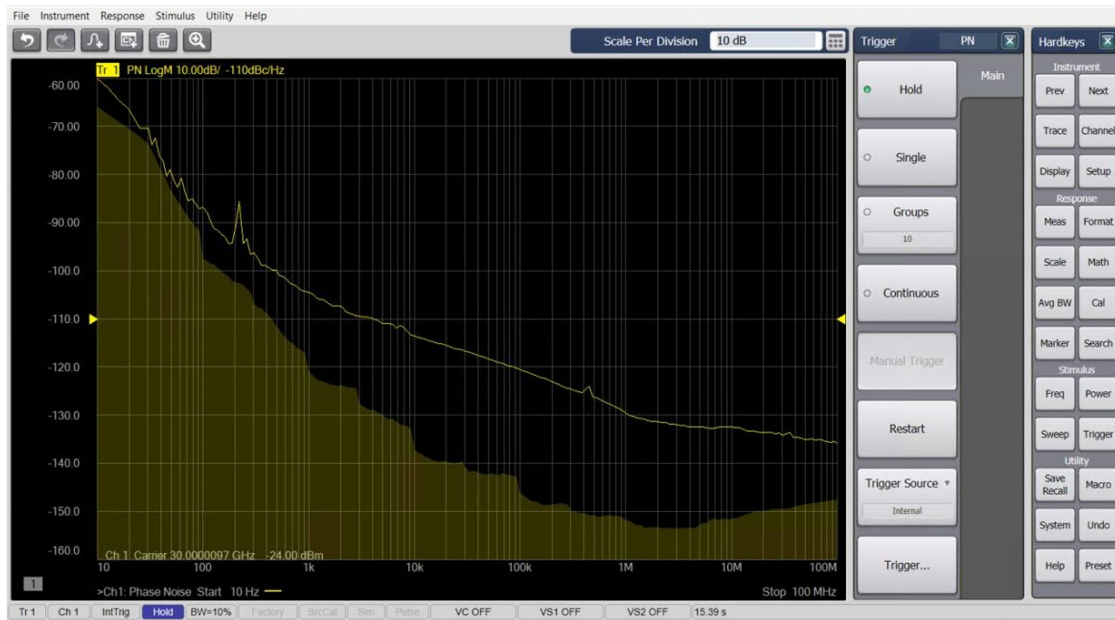

**Figure 12.** Phase noise measurement with SSA-X

If the phase noise of the signal source under test has more than 25 dB better sensitivity than the SSA-X measurement sensitivity at 1 Hz offset, then Keysight N5511A phase noise test system, which provides the highest phase noise measurement performance is required.

The Keysight N5511A Phase Noise Test System (PNTS), part of the PN7-class of Keysight Phase Noise Analyzers, is a replacement for the “gold-standard” Keysight E5500 phase noise measurement system. It is modular-based measurement system uses the PXIe standard. Flexible configurations are possible for a variety of phase noise measurement techniques, including PLL/reference source, residual and FM discriminator methods. The main components of the solution include the phase detector modules, data converter module, and a Windows-based PC controller. An additional 100 MHz frequency reference module is used to clock the four ADCs located on the data converter module.



**Figure 13.** Keysight N5511A Phase Noise Test System (PNTS)

PNTS can be configured as a single (one phase detector module) or dual channel system (two phase detector modules).

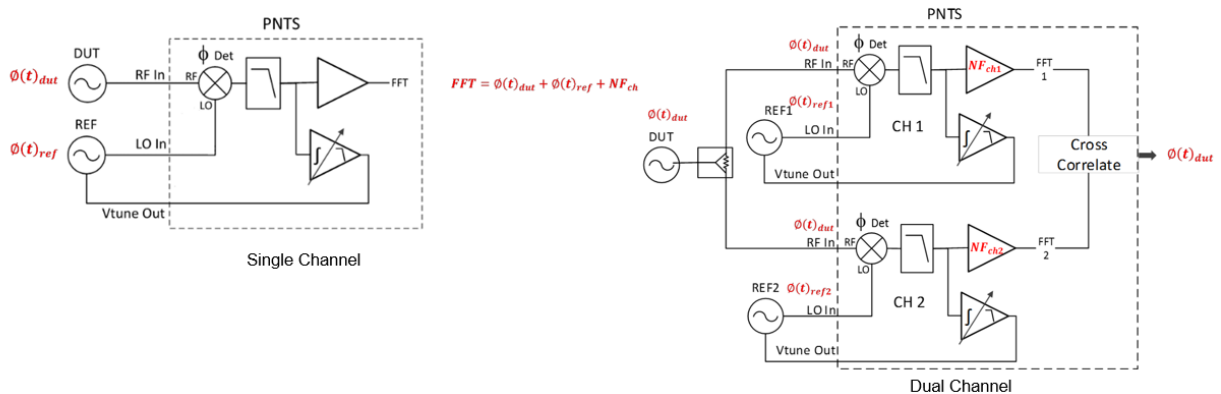

**Figure 14.** PNTS simplified single-channel/dual-channel absolute phase noise measurement diagram

In a single-channel system, the output is the sum of the DUT phase noise, reference phase noise, and the noise floor of the detector. It is therefore important that the reference phase noise is much less than the DUT phase noise. In practice, many DUTs has significantly improved phase noise. To combat this limitation engineers commonly introduce dual-channel systems.

In a dual-channel system, cross-spectral averaging takes the cross-spectrum of noise data from two different channels and performs a cumulative average. This process reduces the uncorrelated noise relative to the correlated noise. There is no limit to the amount of uncorrelated noise that can be removed until you reach the limit of thermal noise floor (-177 dBm/Hz).

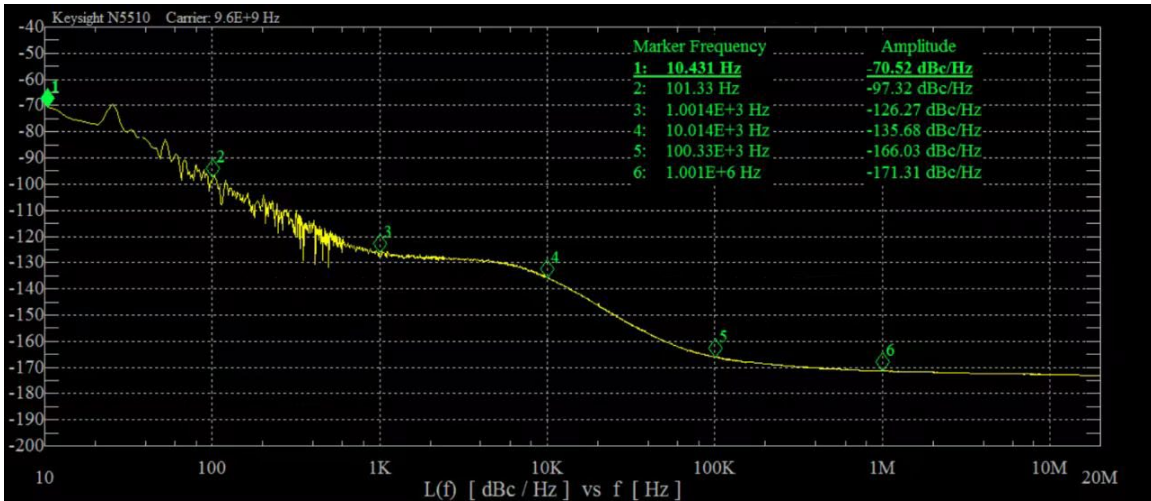

**Figure 15.** Phase noise measurement with PNTS system

In addition to the above instruments, Keysight also offers solutions for measuring phase noise using oscilloscopes and network analyzers. For example, S930321B enables phase noise measurements using a PNA, part of the XN7-class of Keysight Expert Vector Network Analyzer, or PNA-X, part of the XN8-class of Keysight Pro Vector Network Analyzer, vector network analyzer. Simplify your measurement workflow by measuring phase noise on the same connection as your network analysis measurement of 2-port active devices up to 125 GHz, without needing to connect a spectrum analyzer or harmonic mixer, 0.1 Hz to 10 MHz offset frequency range. D9020JITA Jitter, Vertical, and Phase Noise Analysis Software for Infiniium 90000, V-, Z-, and UXR-Series Oscilloscopes.

## Comparison of different instruments for phase noise measurement

| Instrument                            | Description   | Capabilities   |
|---------------------------------------|---|--|
| Spectrum Analyzer                     | Combination signal analyzer and phase noise analysis with embedded phase noise application            | <ul style="list-style-type: none"> <li>○ Absolute/ AM</li> <li>○ Input frequency depends on instrument</li> <li>○ Instrument and input signal determine offset frequency range</li> <li>○ Direct spectrum method</li> </ul>  |
| SSA-X                                 | All-in-one, high-performance signal source (phase noise) analysis and VCO test                        | <ul style="list-style-type: none"> <li>○ Absolute/ AM/Baseband/Pulse/ Transient Analysis</li> <li>○ Input frequency depends on instrument</li> <li>○ 1 MHz to &gt;1 GHz offset frequency range</li> <li>○ DC control and power supplies for VCO test</li> <li>○ Cross correlation</li> <li>○ Direct spectrum method</li> </ul> |
| N5511A Phase Noise Test System (PNTS) | Highly flexible, high- performance phase noise test system  | <ul style="list-style-type: none"> <li>○ Absolute/Residual/AM/Baseband/ Pulse</li> <li>○ Input frequency 50 kHz to 40GHz</li> <li>○ 50 kHz to 160 MHz offset frequency range</li> <li>○ Cross correlation</li> <li>○ Analog phase detector method</li> <li>○ Extendable to mmWave frequencies</li> </ul>                       |
| Network Analyzers                     | Combination network analyzer and phase noise analysis with embedded phase noise application           | <ul style="list-style-type: none"> <li>○ Absolute/Residual/ AM</li> <li>○ Input frequency 10 MHz to 70 GHz/125 GHz</li> <li>○ Direct spectrum method</li> </ul>  |
| Oscilloscopes                         | Combination oscilloscope and phase noise/jitter analysis with embedded phase noise/jitter application | <ul style="list-style-type: none"> <li>○ Absolute/AM/Baseband</li> <li>○ Input/ offset frequency combination up to the full BW</li> <li>○ Cross correlation</li> <li>○ AM/PM separation to the full frequency range</li> <li>○ Direct spectrum method</li> </ul>   |

### For more information

To learn more about Keysight's phase-noise solutions, visit:

<http://www.keysight.com/find/phasenoise>

# Conclusion

This article introduces the concept of phase noise and common testing methods. It concludes with an overview of the phase noise measurement instruments provided by Keysight, aiming to help customers understand some basic knowledge about phase noise and choose the appropriate measurement instruments and solutions based on their actual needs.

# FAQ

## 1. What is Phase Noise?

Phase noise refers to the frequency instability in a signal's spectrum caused by phase jitter. It typically manifests as spectral spreading around the carrier frequency, affecting the signal's purity and stability.

## 2. Why is phase noise important in communication systems?

Phase noise is crucial in communication systems because it can degrade the performance of the system by causing signal distortion, reducing signal-to-noise ratio, and increasing bit error rates. High phase noise can lead to poor signal quality and reduced data transmission rates.

## 3. What are the primary techniques used by Keysight for phase noise measurement?

Keysight employs several techniques for phase noise measurement, including the direct spectrum method, phase detector method, and two-channel cross-correlation method. Each technique has its advantages depending on the specific measurement requirements.

## 4. How does the direct spectrum method measure phase noise?

The direct spectrum method involves inputting the signal from the device under test into a spectrum analyzer tuned to the device's frequency. The analyzer measures the power spectral density of the oscillator, providing a direct measurement of phase noise.

## 5. What is the phase detector method and when is it used?

The phase detector method uses a phase detector to convert the phase difference between two input signals into a voltage. This method is used when it is necessary to separate phase noise from amplitude noise, providing a more accurate phase noise measurement.

## 6. What is the two-channel cross-correlation technique?

The two-channel cross-correlation technique involves using two identical reference sources and performing cross-correlation operations between their outputs. This technique enhances measurement sensitivity without requiring high-performance hardware components.

Keysight enables innovators to push the boundaries of engineering by quickly solving design, emulation, and test challenges to create the best product experiences. Start your innovation journey at [www.keysight.com](http://www.keysight.com).