Keysight N777-C Series Tunable Laser Family

N7776C Tunable Laser Source

N7778C Tunable Laser Source

N7779C Tunable Laser Source

Notices

© Keysight Technologies 2024

No part of this manual may be reproduced in any form or by any means (including electronic storage and retrieval or translation into a foreign language) without prior agreement and written consent from Keysight Technologies as governed by United States and international copyright laws.

Manual Part Number

N7770-90B02

Edition

Edition 3.1, February 2024

Keysight Technologies Deutschland GmbH
Herrenberger Strasse 130,
71034 Böblingen, Germany

Technology Licenses

The hardware and/or software described in this document are furnished under a license and may be used or copied only in accordance with the terms of such license.

U.S. Government Rights

The Software is “commercial computer software,” as defined by Federal Acquisition Regulation (“FAR”) 2.101. Pursuant to FAR 12.212 and 27.405-3 and Department of Defense FAR Supplement

(“DFARS”) 227.7202, the U.S. government acquires commercial computer software under the same terms by which the software is customarily provided to the public. Accordingly, Keysight provides the Software to U.S. government customers under its standard commercial license, which is embodied in its End User License Agreement (EULA), a copy of which can be found at:

<http://www.keysight.com/find/sweula>.

The license set forth in the EULA represents the exclusive authority by which the U.S.

government may use, modify, distribute, or disclose the Software. The EULA and the license set forth therein, does not require or permit, among other things, that Keysight: (1) Furnish technical information related to commercial computer software or commercial computer software documentation that is not customarily provided to the public; or (2) Relinquish to, or otherwise provide, the government rights in excess of these rights customarily provided to the public to use, modify, reproduce, release, perform, display, or disclose commercial computer software or commercial computer software documentation. No additional government requirements beyond those set forth in the EULA shall apply, except to the extent that those terms, rights, or licenses are explicitly required from all providers of commercial computer software pursuant to the FAR and the DFARS and are set forth specifically in writing elsewhere in the EULA. Keysight shall be under no obligation to update, revise or otherwise modify the Software. With respect to any technical data as defined by FAR 2.101, pursuant to FAR 12.211 and 27.404.2 and DFARS 227.7102, the U.S. government acquires no greater than Limited Rights as defined in FAR 27.401 or DFAR 227.7103-5 (c), as applicable in any technical data.

Warranty

THE MATERIAL CONTAINED IN THIS DOCUMENT IS PROVIDED “AS IS,” AND IS SUBJECT TO BEING CHANGED, WITHOUT NOTICE, IN FUTURE EDITIONS. FURTHER, TO THE MAXIMUM EXTENT PERMITTED BY APPLICABLE LAW, KEYSIGHT DISCLAIMS ALL WARRANTIES, EITHER EXPRESS OR IMPLIED WITH REGARD TO THIS MANUAL AND ANY INFORMATION CONTAINED HEREIN, INCLUDING BUT NOT LIMITED TO THE IMPLIED WARRANTIES OF MERCHANTABILITY AND FITNESS FOR A PARTICULAR PURPOSE. KEYSIGHT SHALL

NOT BE LIABLE FOR ERRORS OR FOR INCIDENTAL OR CONSEQUENTIAL DAMAGES IN CONNECTION WITH THE FURNISHING, USE, OR PERFORMANCE OF THIS DOCUMENT OR ANY INFORMATION CONTAINED HEREIN. SHOULD KEYSIGHT AND THE USER HAVE A SEPARATE WRITTEN AGREEMENT WITH WARRANTY TERMS COVERING THE MATERIAL IN THIS DOCUMENT THAT CONFLICT WITH THESE TERMS, THE WARRANTY TERMS IN THE SEPARATE AGREEMENT WILL CONTROL.

Safety Notices

CAUTION

A CAUTION notice denotes a hazard. It calls attention to an operating procedure, practice, or the like that, if not correctly performed or adhered to, could result in damage to the product or loss of important data. Do not proceed beyond a CAUTION notice until the indicated conditions are fully understood and met.

WARNING









A WARNING notice denotes a hazard. It calls attention to an operating procedure, practice, or the like that, if not correctly performed or adhered to, could result in personal injury or death. Do not proceed beyond a WARNING notice until the indicated conditions are fully understood and met.

Safety Summary

The following general safety precautions must be observed during all phases of operation of this instrument. Failure to comply with these precautions or with specific warnings or operating instructions in the product manuals violates safety standards of design, manufacture, and intended use of the instrument. Keysight Technologies assumes no liability for the customer's failure to comply with these requirements. Product manuals are provided on the Web. Go to www.keysight.com and type in your product number in the Search field at the top of the page.

General	<p>This product is a Protection Class 1 instrument (provided with a protective earth terminal) and has been manufactured and tested according to international safety standards. The protective features of this product may be impaired if it is used in a manner not specified in the operation instructions.</p> <p>All Light Emitting Diodes (LEDs) used in this product are Class 1 LEDs as per IEC 60825-1:2014.</p>
Environment Conditions	<p>This instrument is intended for indoor use in an Overvoltage Category II, pollution degree 2 environment. It is designed to operate at a maximum relative humidity (RH) of 80%, non-condensing and at altitudes of up to 2000 meters. Refer to the specifications tables for the AC mains voltage requirements and ambient operating temperature range.</p>
Temperature	<p>The instrument should be protected from temperature extremes and changes in temperature that may cause condensation within it.</p> <p>The operating temperature is from 10 °C to +35 °C</p> <p>The storage temperature is from –40 °C to +70 °C (Option D00, standard front panel) –30 °C to +70 °C (Option D01, touchscreen display)</p>
Before Applying Power	<p>Verify that all safety precautions are taken. The power cable inlet of the instrument serves as a device to disconnect from the mains in case of hazard. The instrument must be positioned so that the operator can easily access the power cable inlet. When the instrument is rack mounted the rack must be provided with an easily accessible mains switch.</p>
Ground the Instrument	<p>To minimize shock hazard, the instrument chassis and cover must be connected to an electrical protective earth ground. The instrument must be connected to the AC power mains through a grounded power cable, with the ground wire firmly connected to an electrical ground (safety ground) at the power outlet. Any interruption of the protective (grounding) conductor or disconnection of the protective earth terminal will cause a potential shock hazard that could result in personal injury.</p>
Do Not Operate in an Explosive Atmosphere	<p>Do not operate the instrument in the presence of flammable gases or fumes.</p>
Do Not Remove the Instrument Cover	<p>Operating personnel must not remove instrument covers. Component replacement and internal adjustments must be made only by qualified personnel.</p> <p>Instruments that appear damaged or defective should be made inoperative and secured against unintended operation until they can be repaired by qualified service personnel.</p>

Instrument Markings

Instrument Marking	Description
	<p>The instruction manual symbol. The product is marked with this warning symbol when it is necessary for the user to refer to the instructions in the manual.</p>
	<p>Standby supply. Unit is not completely disconnected from AC mains when switch is off.</p>
	<p>The CE mark is a registered trademark of the European Community.</p>
	<p>The CSA mark with the 'c' and 'us' subscript indicates the instrument is certified to the applicable Canadian and United States of America standards respectively.</p>
	<p>The C-tick mark is a registered trademark of the Spectrum Management Agency of Australia. This signifies compliance with the Australian EMC Framework regulations under the terms of the Radio Communications Act of 1992</p>
	<p>This symbol is a South Korean Class A EMC Declaration, with the product identification code "R-R-Kst-3E19590". R - Identification of authorization prefix. R - Identification of basic certification information. Kst - Identification of applicant's information 3E19590 - Product identification. This is a Class A instrument suitable for professional use and in electromagnetic environment outside of the home.</p>
	<p>The recycling symbol indicates the general ease with which the instrument can be recycled.</p>
	<p>China Restricted Substance Product Label. The EPUP (environmental protection use period) number in the center indicates the time period during which no hazardous or toxic substances or elements are expected to leak or deteriorate during normal use and generally reflects the expected useful life of the product.</p>

South Korean Class A EMC Declaration

Information to the user:

This instrument has been conformity assessed for used in business environments. In a residential environment this equipment may caused radio interference.

This EMC statement applies to the equipment only for use in business environment.



사용자 안내문

이 기기는 업무용 환경에서 사용할 목적으로 적합성 평가를 받은 기기로서 가정용 환경에서 사용하는 경우 전파 간섭의 우려가 있습니다.

사용자 안내문은 "업무용 방송통신기자재"에만 적용한다.

Compliance and Environmental Information

Table 1 Compliance and Environmental Information

Safety Symbol	Description
	<p>This product complies with WEEE Directive (2002/96/EC) marking requirements. The affixed label indicates that you must not discard this electrical/electronic product in domestic household waste.</p> <p>Product Category: With reference to the equipment types in WEEE Directive Annex I, this product is classed as a "Monitoring and Control instrumentation" product.</p> <p>Do not dispose in domestic household waste.</p>
	<p>To return unwanted products, contact your local Keysight office, or see http://about.keysight.com/en/companyinfo/environment/takeback.shtml for more information.</p>

Declaration of Conformity

Declarations of Conformity for this product and for the Keysight products may be downloaded from the Web. Go to <http://www.keysight.com/go/conformity>.

You can then search by product number to find the latest Declaration of Conformity.

Contents

Safety Summary	3
Instrument Markings	4
South Korean Class A EMC Declaration	5
Compliance and Environmental Information	5
Declaration of Conformity	5

1 General Operating Considerations

Overview	14
Laser Safety Information	15
Initial Safety Information for Keysight N777-C Family Lasers	15
Laser Safety Labels	16
Laser Safety Symbols	17
Operating Environment	18
Handling the Instrument	20
Storage and Shipment	20
Carrying the Instrument	20
Rack Mount the Instrument	20
Obtaining Source Code	22

2 Getting Started

Initial Inspection	24
Initial Inspection	24
Claims and Repackaging	24
Return Shipments to Keysight Technologies	25

Power Supply Requirements	26
Line Power Requirements	26
N777-C Series of Tunable Laser Family	28
The Keysight N7776C Top-Line Tunable Laser Source	28
The Keysight N7778C Value Line Tunable Laser Sources	28
The Keysight N7779C Basic Line Step-Tunable Laser Source	29
O-band option for Silicon Photonics/ Integrated Photonics Applications	29
E-band option for CWDM8 Component Testing	29
N777-C Front and Rear Panel	30
Input/Output Signals	32
Optical Output	32
Powering Up the Instrument	35
Remote Interface	36
LAN Connection with a DHCP server (Site LAN)	36
LAN Connection without a DHCP server (Private LAN)	37
USB Connection	38
Technical Overview	39
The LAN Status Indicators	39
The LAN Reset button	40
Deleting User Data	41
Connecting the Instrument	42
Connecting over USB	42
Connecting over LAN	43
N777-C User Interface	46

3 Definition of Terms

Definition of Terms	50
General Definitions	50
Absolute wavelength accuracy (continuous sweep mode)	51
Absolute wavelength accuracy (stepped mode)	51
Dynamic power reproducibility (continuous sweep mode)	51
Dynamic relative power flatness (continuous sweep mode)	52
Effective linewidth	52
Linewidth	53
Maximum output power	53
Mode-hop free tunability	54
Operating temperature and humidity	54
Output isolation	54
Polarization extinction ratio	54
Power flatness versus wavelength	55
Power linearity	56
Power repeatability	56
Power stability	57
Relative intensity noise (RIN)	57
Relative wavelength accuracy (continuous sweep mode)	58
Relative wavelength accuracy (stepped mode)	58
Return loss	59
Side-mode suppression ratio	59
Signal to source spontaneous emission (SSE) ratio	60
Signal to total source spontaneous emission ratio	61
Wavelength range	61
Wavelength repeatability (continuous sweep mode)	61
Wavelength repeatability (stepped mode)	62
Wavelength resolution	63
Wavelength stability	63

4 N777-C Web Interface Reference

N777-C Web Interface	66
Controlling N777-C Instruments	68
Control Instrument Tab	68
How to set Wavelength?	71
How to Set Power?	71
How to Perform a Wavelength Sweep?	73
How to Use Triggers?	76
How to set Modulation?	78
How to Lock/Unlock the Instrument?	79
How to Turn ON/OFF the Laser?	79
How to Apply Display Settings?	80
How to Apply Device Settings?	81
How to Use Auxiliary Functions	82
How to Get Current Instrument Settings?	82
How to Identity a Particular instrument?	83
How to Capture an Image of the Graph?	83
How to Export and Import the User Interface Settings?	84
How to Save and Recall the Instrument's Measurement Settings?	85
Logging In/Out of the N777-C Web Interface	86
How to Create/Change the Password?	87
What If You Forget Your Password?	87
How to Perform Realignment?	88
Lambda Zeroing	88
Update Rate	90
How to Reboot a Device?	91
How to Preset a Device?	92
How to Configure LAN?	92

5 N777-C Instrument's Front Panel Display

N777-C Instrument's Front Panel Display 96

Controlling N777-C Instruments 98

- Control Instrument Window 98
- How to set Wavelength? 101
- How to Set Power? 102
- How to Perform a Wavelength Sweep? 103
- How to Use Triggers? 107
- How to set Modulation? 110
- How to Lock/Unlock the Instrument? 111
- How to Turn ON/OFF the Laser Output? 111
- How to Get Current Instrument Settings? 111
- How to Configure LAN? 113

6 Maintenance

Cleaning Instructions 118

- Safety Precautions 118
- Why is it important to clean optical devices? 118
- What materials do I need for proper cleaning? 119
- General Cleaning Procedure 121

Further Cleaning Information 122

Firmware Upgrades 123

- Requirements 123

Contact Keysight Technologies 124

Keysight N777-C Series Tunable Laser Family

User's Guide

1 General Operating Considerations

[Overview](#) / 14

[Laser Safety Information](#) / 15

[Operating Environment](#) / 19

[Handling the Instrument](#) / 21

[Obtaining Source Code](#) / 23

Overview

The following general safety precautions must be observed during all phases of operation, service, and repair of this instrument. Failure to comply with these precautions or with specific warnings elsewhere in this manual violates safety standards of design, manufacture, and intended use of the instrument. Keysight Technologies assumes no liability for the customer's failure to comply with these requirements.

WARNING

Ensure the proper usage for the instrument. The protection provided by the instrument may be impaired. The operator of this instrument is advised to use the equipment in a manner as specified in this document

Before operation, you should review the instrument and manual for safety markings and instructions. You must follow these to ensure safe operation and to maintain the instrument in safe condition.

Some circuits are powered whenever the instrument is connected to the AC power source. To disconnect from the line power, disconnect the power cord either at the rear power inlet or at the AC line power source (receptacle). One of these must always be accessible. If the instrument is in a cabinet, it must be disconnected from the line power by the system's line power switch.

WARNING

To avoid hazardous electrical shock, do not perform electrical tests when there are signs of shipping damage to any portion of the outer enclosure (covers, panels, etc.).

WARNING

Please pay attention to the following laser safety warning:

Under no circumstances look into the end of an optical cable attached to the optical output when the instrument is operational. The laser radiation can seriously damage your eyesight. Do not enable the laser when there is no fiber attached to the optical output connector. Refer servicing only to qualified and authorized personnel.

Laser Safety Information

Initial Safety Information for Keysight N777-C Family Lasers

Initial Safety Information for Keysight N777-C Family Lasers.

The laser sources specified by this user's guide are classified according to IEC 60825-1:2014 and EN 60825-1:2014/A11:2021.

The laser sources comply with 21 CFR 1040.10 except for deviations pursuant to Laser Notice No. 50 dated 2007, June 24.

Table 2 Laser Source Specification

	N7776C #216 N7778C #216 N7779C #216	N7778C #215	N7776C #116 N7778C #116 N7779C #116
Laser type	EC-Laser InGaAsP	EC-Laser InGaAsP	EC-Laser InGaAsP
Wavelength range	1450 – 1650 nm	1440 – 1640 nm	1490 – 1640 nm
Max. CW output power*	< 25 mW	< 25 mW	< 25 mW
Beam waist diameter	9 μm	9 μm	9 μm
Numerical aperture	0.1	0.1	0.1
Laser class according to IEC 60825-1:2014	1M	1M	1M
Max. permissible CW output power	140 mW – 185 mW	140 mW – 180 mW	150 mW – 180 mW
<i>* Max. CW output power is defined as the highest possible optical power that the laser source can produce at its output connector.</i>			

	N7776C #114 N7778C #114 N7779C #114	N7776C #113 N7778C #113 N7779C #113	N7776C #013 N7778C #013
Laser type	EC-Laser InGaAsP	EC-Laser InGaAsP	EC-Laser InGaAsP
Wavelength range	1340 nm – 1495 nm	1240 nm– 1380 nm	1250 nm– 1370 nm
Max. CW output power*	< 60 mW	< 30 mW	< 44 mW – 400 mW
Beam waist diameter	9 μm	9 μm	9 μm
Numerical aperture	0.1	0.1	0.1
Laser class according to IEC 60825-1:2014	1M	1M	1M
Max. permissible CW output power	500 mW (< 1400 nm) 135 mw - 150 mW (≥ 1400 nm)	50 mW– 500 mW	55 mW– 500 mW
* Max. CW output power is defined as the highest possible optical power that the laser source can produce at its output connector.			

Laser Safety Labels

Laser Class 1M Label

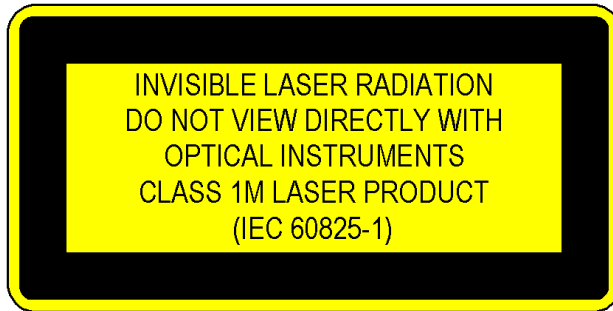

Figure 1 Laser Class 1M Label

A sheet of laser safety labels is included with the laser instrument. In order to meet the requirements of IEC 60825-1:2014, we recommend that you stick the laser safety labels, in your language, onto a suitable location on the outside of the instrument where they are clearly visible to anyone using the instrument.

WARNING

Please pay attention to the following laser safety warning:

Under no circumstances look into the end of an optical cable attached to the optical output when the instrument is operational. The laser radiation can seriously damage your eyesight. Do not enable the laser when there is no fiber attached to the optical output connector. The laser can be enabled by pressing the “active” button close to the optical output connector on the front panel of the instrument or by remote control. The laser is on when the green LED, above the optical output, on the front panel of the instrument is lit. The use of optical instruments with this product will increase eye hazard. The laser instrument has a built-in safety circuitry which will disable the optical output in the case of a fault condition. Refer servicing only to qualified and authorized personnel.

Laser Safety Symbols



The apparatus will be marked with this symbol when it is necessary for the user to refer to the instruction manual in order to protect the apparatus against damage.



Hazardous laser radiation.

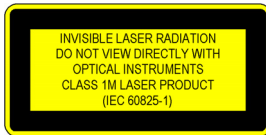

Invisible laser radiation.

Operating Environment

Overview

In order for the instrument to meet specifications, the operating environment must be within these limits. Refer to [Safety Summary](#) on page 3.

WARNING

The instrument is not designed for outdoor use. To prevent potential fire or shock hazard, do not expose the instrument to rain or other excessive moisture.

Instrument Cooling

The instrument has a cooling fan mounted internally.

Mount or position your instrument upright and horizontally, as shown in the following figure so that air can circulate through it freely.

Operating Position

When operating the instrument choose a location that provides at least 75 mm (3 inches) of clearance at the rear, and at least 25 mm (1 inch) of clearance at each side. Failure to provide adequate air clearance may result in excessive internal temperature, reducing instrument reliability. The instrument should not be operated when resting on its rear or side panels.

[Figure 2](#) shows the correct operating position of Keysight N777-C instrument.

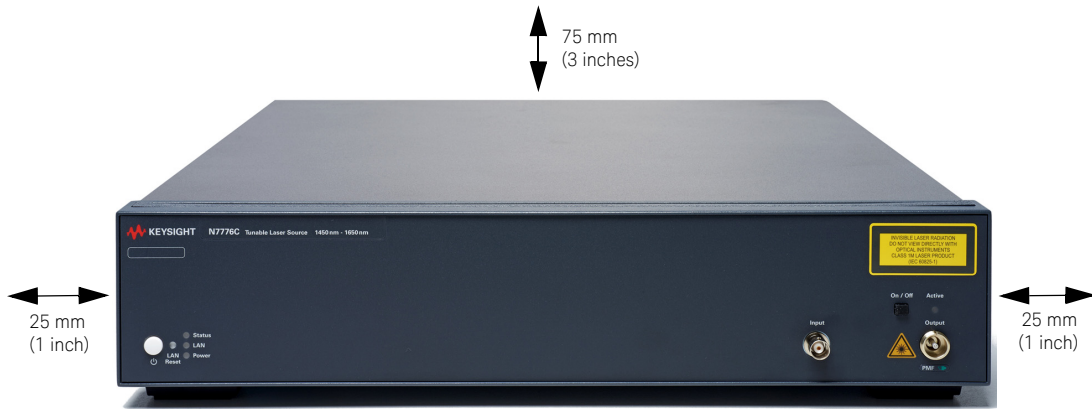

Figure 2 Operating Position of the Instrument

Handling the Instrument

Storage and Shipment

Lasers can be stored or shipped at temperatures between $-40\text{ }^{\circ}\text{C}$ to $+70\text{ }^{\circ}\text{C}$ (Option D00, standard front panel) and between $-30\text{ }^{\circ}\text{C}$ to $+70\text{ }^{\circ}\text{C}$ (Option D01, touchscreen display). Protect the laser from temperature extremes that may cause condensation within it.

The Keysight N777-C Tunable Laser System can be stored either in its operating position or on its back legs. The back legs protect the connectors on the back panel from damage.

Carrying the Instrument

Grasp the strap to carry the instrument.

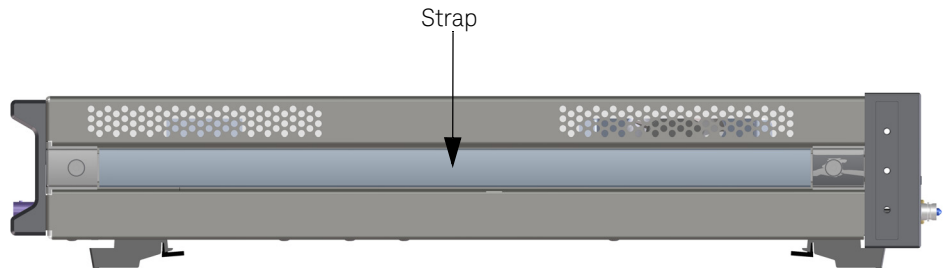

Figure 3 Carrying an Instrument

Rack Mount the Instrument

You can mount the instrument in a standard 19-inch rack cabinet using an optional kit, which includes instructions and mounting hardware.

NOTE

Remove the carrying strap, and the front and rear rubber bumpers feet, before mounting the instrument in a rack.

To rack mount a single instrument, order adapter kit N7799C-2CM.
Figure 4 shows an example where an instrument is mounted on a rack:

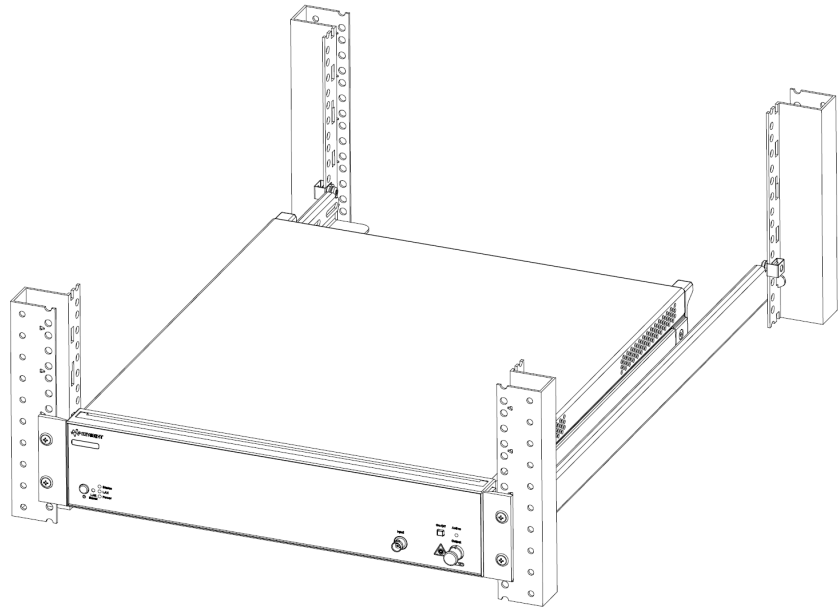

Figure 4 Instrument Mounted on a Rack

Obtaining Source Code

This product uses open source packages. To the extent required by the applicable open source license(s), Keysight makes source code available upon request. To request source code, please contact **Keysight Support** at www.keysight.com/main/support.jspx.

Third party software acknowledgments and licenses for the N777-C series with the embedded Linux operating system are located at: www.keysight.com/find/N7776C.

2 Getting Started

[Initial Inspection](#) / 26

[Power Supply Requirements](#) / 28

[N777-C Series of Tunable Laser Family](#) / 30

[N777-C Front and Rear Panel](#) / 32

[Input/Output Signals](#) / 34

[Powering Up the Instrument](#) / 37

[Remote Interface](#) / 38

[Deleting User Data](#) / 43

[Connecting the Instrument](#) / 44

[N777-C User Interface](#) / 48

Initial Inspection

Initial Inspection

Inspect the shipping container for damage. If there is damage to the container or cushioning, keep them until you have checked the contents of the shipment for completeness and verified the instrument both mechanically and electrically.

The Performance Tests give procedures for checking the operation of the instrument. If the contents are incomplete, mechanical damage or defect is apparent, or if an instrument does not pass the operator's checks, notify the nearest Keysight Technologies Sales/Service Office.

WARNING

You MUST return malfunctioning instruments to a Keysight Technologies Sales/Service Center for repair and calibration.

Claims and Repackaging

If physical damage is evident or if the instrument does not meet specification when received, notify the carrier and the nearest Keysight Technologies Sales/Service Office. The Keysight Technologies Sales/Service Office will arrange for repair or replacement of the unit without waiting for settlement of the claim against the carrier.

Return Shipments to Keysight Technologies

If the instrument is to be shipped to an Keysight Technologies Sales/Service Office, attach a tag showing owner, return address, model number and full serial number and the type of service required.

The original shipping carton and packing material may be reusable, but the Keysight Technologies Sales/Service Office will provide information and recommendations on materials to be used if the original packing is no longer available or reusable. General instructions for repackaging are as follows:

- Wrap instrument in heavy paper or plastic.
- Use strong shipping container. A double wall carton made of 350-pound test material is adequate.
- Use enough shock absorbing material (3 to 4 inch / 7.5 to 10 cm layer) around all sides of the instrument to provide a firm cushion and prevent movement inside container. Protect control panel with cardboard.
- Seal shipping container securely.
- Mark shipping container FRAGILE to encourage careful handling.
- In any correspondence with Keysight, refer to the instrument by model number and serial number.

Power Supply Requirements

Line Power Requirements

Line Power Requirements

The instrument complies with Overvoltage Category II and can operate from the single-phase AC power source that supplies between 100 V and 240 V at a frequency in the range 50/60 Hz. The maximum voltage fluctuation is 10% of the nominal supply voltage. The maximum power consumption is 200 VA with all options installed.

Line Power Cable

In accordance with international safety standards, the instrument has a three-wire power cable. When connected to an appropriate AC power receptacle, this cable earths the instrument cabinet.

CAUTION

Please note that the switch on the front panel of the instrument does not stop the flow of power to the instrument.

If you need to turn off the power, unplug the instrument at the mains or remove the power cable connector from the appliance coupler at the rear of the instrument. For this reason, the power cable connection should be easily accessible - allowing you to turn off the power quickly. If the instrument is in a cabinet, it must be disconnected from the line power by the system's line power switch.

The power switch allows you to switch between stand-by mode and power-on mode.



Figure 5 Power LED on the Front Panel of the Instrument

When the instrument is in stand-by mode, the Power LED is orange. When the instrument is powered-on, the Power LED is green.

The AC power requirements are summarized on the rear panel of the instrument.

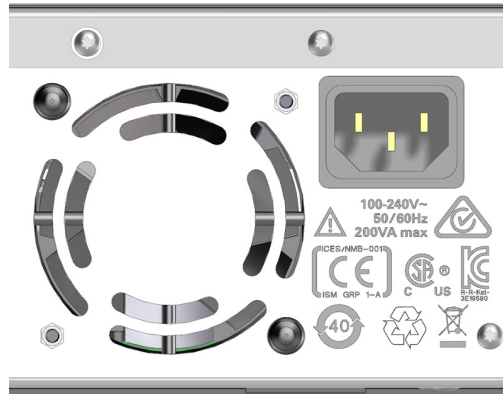

Figure 6 AC Power Requirement Markings

N777-C Series of Tunable Laser Family

The Keysight Technologies N777-C Family of Tunable Laser Sources offers the full wavelength range from 1240 nm to 1650 nm with no wavelength gaps.

The N777-C tunable laser sources realize the cost efficiency and performance required to test components for coarse and dense wavelength division multiplexing (CWDM, DWDM, 100GBASE-LR4) and passive optical networks (PON). Whether you need to verify the design of demanding optical components or adjust more wavelength-selective switches per hour, or you simply need a stable, tunable optical source, the N777-C family of tunable lasers offers a suitable model.

All N777-C models are based on a common cavity and laser instrument design and share a narrow linewidth, excellent long-term stability and low spontaneous emission level. They are software compatible with the 8160xA and 81600B lasers, the industry standards for more than a decade, but occupy 1 height unit less rack space.

For further details on its features, application and specifications, refer to the product datasheet available on www.keysight.com.

The Keysight N7776C Top-Line Tunable Laser Source

The new Keysight N7776C top line tunable laser source is designed to reach best-in-class accuracy and sub-picometer repeatability in static and swept operation for outstanding test efficiency.

With the product family's lowest spontaneous emission level, the N7776C enables the validation of extremely deep filters. It also offers the best wavelength accuracy in the family – enabled by its high-resolution wavelength reference unit that provides real-time tracking and control and includes a gas cell for excellent long-term stability and self-adjustment capability.

The Keysight N7778C Value Line Tunable Laser Sources

The new N7778C value line tunable laser source offers a peak output power of more than +12 dBm, at least 75 dB/nm above its spontaneous emission level. It features a typical wavelength repeatability of ± 1.5 pm at two-way sweeps up to 200 nm/s. The N7778C's balance of features, performance and price makes it suitable for cost-effective, high-throughput manufacturing-floor component testing as well as for coherent transmission experiments.

The Keysight N7779C Basic Line Step-Tunable Laser Source

The new N7779C basic line tunable laser source, like the other new N777-C models, can step quickly to discrete wavelengths with a resolution of 0.1 pm and a typical wavelength repeatability of ± 3 pm, making it ideal for cost-effective testing of broadband optical devices. With wavelength setting times like 300 ms, rapid stepped sweeps are possible. Like the other lasers in the N777-C family, it delivers more than +12 dBm peak output power with low spontaneous emission levels. At ± 0.01 dB power stability over an hour, it can also serve as a static local oscillator with a wide tuning range for receiver testing or transmission experiments.

O-band option for Silicon Photonics/ Integrated Photonics Applications

The N777-C option 113 covers the wavelength range from 1240 nm to 1380 nm for an important set of applications. Equipped with PMF output fiber, these are a good match for testing and developing components with Silicon Photonics technology. Verifying the spectral responsivity and the sensitivity of receiver optical subassemblies (ROSA) for 100G Ethernet benefit from more than +10 dBm output power - enough to allow for external modulation in BER testing. Combined with very low SSE levels, Option 113 is ideal for testing wavelength filters for LR4 components.

E-band option for CWDM8 Component Testing

The N777-C option 114 covers the wavelength range from 1340 nm to 1495 nm. Combined with the other options, this allows measurements over all CWDM channels, such as for CWDM8 devices. Components for Raman amplification also use this wavelength range.

N777-C Front and Rear Panel

This section provides information on the front and rear panels of the N777-C Series Tunable Laser Source.

Figure 7 shows the front panel of the N777-C Series Tunable Laser Source with the optional display unit (Option D01):



Figure 7 Front Panel of the N777-C Instrument with Display

Figure 8 shows the front panel of the N777-C Series Tunable Laser Source without the display (Option D00):



Figure 8 Front Panel of the N777-C Instrument without Display

Figure 9 shows the rear panel of the N777-C Series Tunable Laser Source:

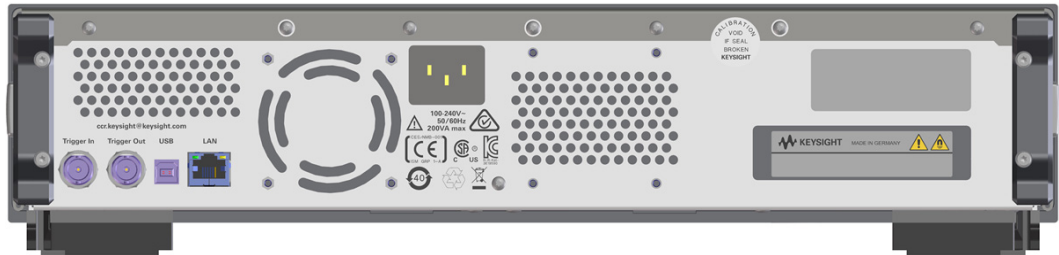

Figure 9 Rear Panel of the N777-C Instrument

Input/Output Signals

CAUTION

Front Panel:

There is one BNC input connector on the front panel of the Keysight N777-C.

An absolute maximum of ± 5 V can be applied as an external voltage to the BNC connector.

CAUTION

Rear Panel:

There is one input BNC connector: Trigger In. This is a TTL input.

A maximum of 5 V can be applied as an external voltage to this input connector.

There is one output BNC connector: Trigger Out. This is a TTL output. Do not apply an external voltage to this connector.

Do not connect multiple Trigger Outputs together.

Optical Output

Polarization Maintaining Fiber

All Keysight N777-C Series Tunable Laser Family instruments include polarization maintaining fiber (PMF) outputs, aligned to maintain the state of polarization.

The fiber is of Panda type, with TE mode in the slow axis in line with the connector key. A well-defined state of polarization ensures constant measurement conditions.

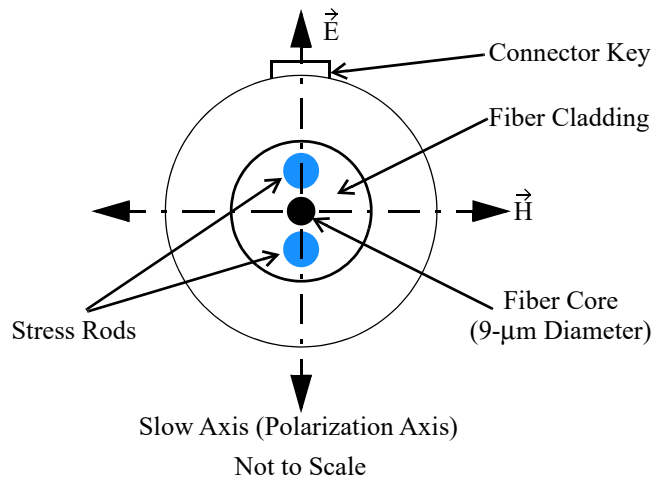

Figure 10 PMF Output Connector

Angled Contact Connectors

The N777-C Series Tunable Laser instruments are outfitted with an angled polished connector. Angled contact connectors help you to control return loss. With angled fiber end-faces, reflected light tends to reflect into the cladding, reducing the amount of light that reflects back to the source. When reflected light remains in the fiber core at two or more locations along the optical path, such as at an open straight-polished connector output to a power meter, double reflections result in multi-path interference of the coherent light and thus power instability in the measurements.

CAUTION

Since the contact connector on your instrument is angled, you can only use cables with angled connectors at the instrument.



Figure 11 Angled and Straight Contact Connector Symbol

Figure 11 shows the symbols that tell you whether the contact connector of your instrument is angled or straight. The angled contact connector symbol is colored green.

You should connect straight contact fiber end connectors with neutral sleeves to straight contact connectors and connect angled contact fiber end connectors with green sleeves to angled contact connectors.

NOTE

You cannot connect angled non-contact fiber end connectors with orange sleeves directly to the instrument.

Powering Up the Instrument

When you power on the instrument, the LEDs on the front panel show the various stages of the instrument.

	Power	LAN	Status
Yellow	Standby mode	Searching for LAN	Warming Up
Green	ON	Connected with LAN	
Blinking Green			Communicating over LAN / USB
Red		Not connected	

Remote Interface

The N777-C supports remote interface communication over a LAN or a USB interface.

NOTE

It is recommended to use the Keysight IO Libraries Suite to enable instrument communication for a variety of development environments. It is available at: <http://keysight.com/find/iolib>s

LAN Connection with a DHCP server (Site LAN)

A site LAN is a local area network in which LAN-enabled instruments and computers are connected to the network through routers, hubs, and/or switches. They are typically large, centrally-managed networks with services such as DHCP and DNS servers. The following figure illustrates a typical site LAN system.

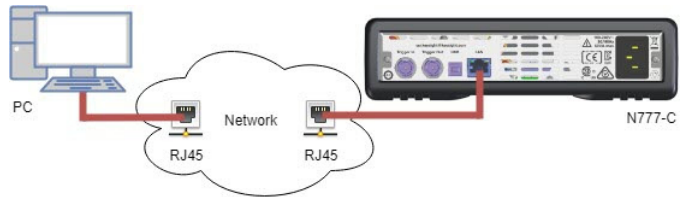

- Connect the instrument to the site LAN or to your computer using a LAN cable. The as-shipped instrument LAN settings are configured to automatically obtain an IP address from the network using a DHCP server (DHCP is set On). The DHCP server will register the instrument's hostname with the dynamic DNS server. The hostname as well as the IP address can then be used to communicate with the instrument. The front panel LAN indicator will indicate the current LAN state (see [The LAN Status Indicators](#) on page 41).
- Use the Connection Expert utility of the Keysight IO Libraries Suite to add the instrument and verify a connection. To add the instrument, you can request the Connection Expert to discover the instrument. If the instrument cannot be found, add the instrument using its host name or IP address.

- You can now use Interactive IO within the Connection Expert to communicate with your instrument, or you can program your instrument using the various programming environments. You can also use the Web browser on your computer to communicate with the instrument as described under [User Interface Reference](#) on page 71.

LAN Connection without a DHCP server (Private LAN)

A private LAN is a network in which LAN-enabled instruments and computers are directly connected, and not connected to a site LAN. They are typically small, with no centrally-managed resources. The following figure illustrates a typical private LAN system.



NOTE

Make sure your computer is configured to obtain its address from DHCP and that NetBIOS over TCP/IP is enabled. Note that if the computer had been connected to a site LAN, it may still retain previous network settings from the site LAN. Wait one minute after disconnecting it from the site LAN before connecting it to the private LAN. This allows the PC to sense that it is on a different network and restart the network configuration.

- The factory-shipped instrument LAN settings are configured to automatically obtain an IP address from a site network using a DHCP server. You can leave these settings as they are. Most Keysight products and most computers will automatically choose an IP address using auto-IP if a DHCP server is not present. Each assigns itself an IP address from the block 169.254.nnn. Note that this may take up to one minute. The front panel LAN indicator will indicate the current LAN state (see [The LAN Status Indicators](#) on page 41).
- Use the Connection Expert utility of the Keysight IO Libraries Suite to add the LAN instrument and verify a connection. To add the instrument, you can request the Connection Expert to discover the LAN instrument. If the instrument cannot be found, add the instrument using its hostname or IP address. You can find additional details here: [Connecting the Instrument](#) on page 44

NOTE

If this does not work, refer to “Troubleshooting Guidelines” in the Keysight Technologies USB/LAN/GPIB Interfaces Connectivity Guide included with the Keysight IO Libraries Suite.

- You can now use Interactive IO within the Connection Expert to communicate with your instrument, or you can program your instrument using the various programming environments. You can also use the Web browser on your computer to communicate with the instrument as described under [User Interface Reference](#) on page 71.

USB Connection

The following figure illustrates a typical USB interface system:



- Connect your instrument to the USB port on your computer using a USB cable.

NOTE

Your PC will detect a new USB Mass Storage Device (read-only) and a new virtual Ethernet link over USB. This interface assigns itself an IP address from the block 100.61.nnn.nnn and your PC 100.61.nnn.nnn (n+1).

- Use the Connection Expert utility of the Keysight IO Libraries Suite to add the instrument and verify a connection. To add the instrument, you can request the Connection Expert to discover the instrument. If the instrument cannot be found, add the instrument using its hostname or IP address. You can find additional details here: [Connecting the Instrument](#) on page 44.
- You can now use Interactive IO within the Connection Expert to communicate with your instrument, or you can program your instrument using the various programming environments.

Technical Overview

User Interface	Keysight N777-C
Ethernet Access: HTTP Telnet VXI-11 SCPI-telnet SCPI-raw	IPv4 and IPv6 Socket connection: http://<ip_address> or http://<host_name> port 23 port 111 (IPv4 only) port 5024 port 5025
USB Access	Remote NDIS (virtual Ethernet link over USB) USB Mass Storage functions (read-only)

The LAN Status Indicators

When the LAN connection is made, you will see the following LAN status indicators:

No LAN Link



LAN Red

LAN Link
No IP Address



LAN Yellow

LAN Link

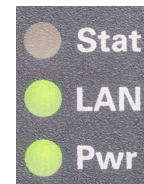

LAN Green

There may be a delay between making the LAN link (yellow status) and getting the IP address (green status). This delay may be longer if there is no DHCP server, for example when the instrument is connected directly to a PC.

The LAN Reset button

This recessed button has two functions.



- Pressing the button briefly invokes a preset of the instrument and restores default measurement settings. This is equivalent to the programming command:
`:SYSTEM:PRESet`
- Pressing and holding the button for 5 seconds will reset the LAN parameters to the factory default. This includes removing the password. This is equivalent to the following programming command:
`:SYSTEM:COMMunicate:ETHernet:RESet`

Deleting User Data

If you need to delete all your logged data and user configurations, press and hold the **LAN Reset** button (approx. 5 sec) to reset the instrument and all your logged data and user configurations will be deleted.

Connecting the Instrument

Connecting over USB

- 1 Power on the instrument.
- 2 Connect the PC to the instrument using a USB cable.
- 3 The operating system will detect and display the new instrument as a new drive.

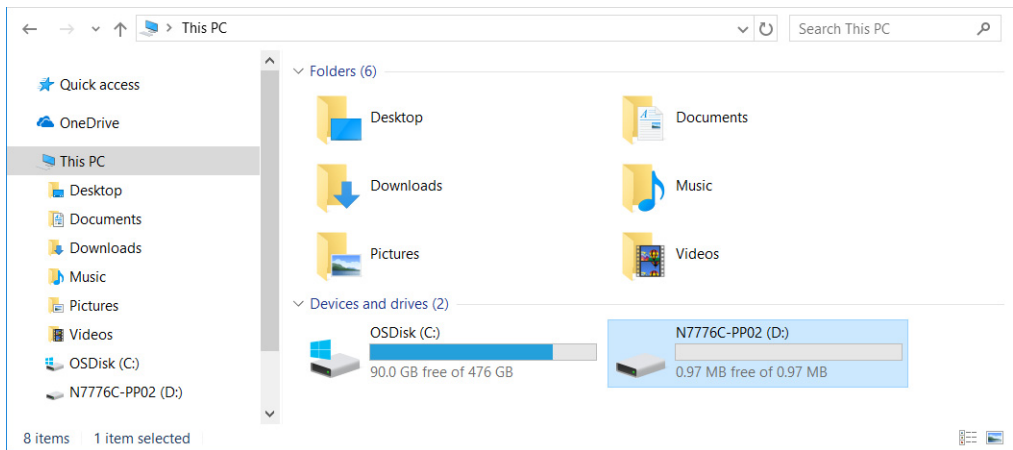

- 4 Double-click on this new drive. It will show a shortcut to start the user interface.

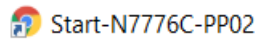

- 5 Double-click on this shortcut. This will open the user interface of the instrument in a browser.

Connecting over LAN

- 1 Make sure the instrument is connected to the LAN, and that the LAN LED on the front panel is green.
- 2 If it is not already running, start the Keysight Connection Expert software.

The Discovery Service automatically discovers LAN instruments on the same subnet as the PC on which the service is running.

- 3 To add LAN instruments to the Connection Expert My Instruments list:
 - a Click, select LAN Instrument from the context list. This opens the list of discovered LAN instruments.

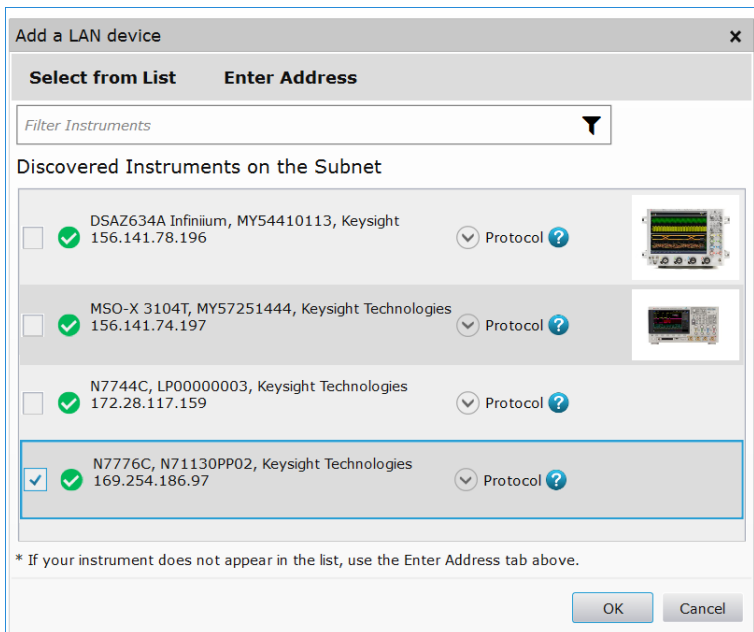

- b Click the check box for each instrument you want to add to the list.
- c Click OK.

- 4 To manually add LAN instruments outside of the local subnet:
 - a Click, select LAN Instrument from the context list. This opens the list of discovered LAN instruments.
 - b Click the Enter Address tab.
 - c Enter the LAN address or host name and select the protocol used to communicate with the instrument. Supported protocols are VXI-11 and Socket.

- d Click OK.

- 5 Linux or macOS can use the zeroconf / mDNS discovery service with tools like Avahi (GNU/Linux) or Bonjour (Mac).

```

steffen@keysight [11:04:34 AM] [~]
-> % avahi-browse --all -t |grep N7781
+ en1 IPv4 N7781C DE0000PP03 Polarization Analyzer      _vxi-11._tcp      local
+ en1 IPv4 N7781C DE0000PP03 Polarization Analyzer      _scpi-telnet._tcp local
+ en1 IPv4 N7781C DE0000PP03 Polarization Analyzer      _scpi-raw._tcp    local
+ en1 IPv4 N7781C DE0000PP03 Polarization Analyzer      _lxi._tcp         local
+ en1 IPv4 N7781C DE0000PP03 Polarization Analyzer      Web Site          local
steffen@keysight [11:11:34 AM] [~]
-> % avahi-browse _scpi-raw._tcp --resolve |grep N7781 -A3
--
= en1 IPv4 N7781C DE0000PP03 Polarization Analyzer      _scpi-raw._tcp    local
hostname = [k-n7781c-0pp03.local]
address = [156.141.78.199]
port = [5025]
txt = ["txtvers=1" "Manufacturer=Keysight Technologies" "Model=N7781C" "SerialNumber=DE0000PP03" "FirmwareVersion=V1.000"]

```

N777-C User Interface

Keysight offers the N777-C Tunable Laser Source instruments with an optional display. [Figure 12](#) shows the user interface accessed in the instrument's display:

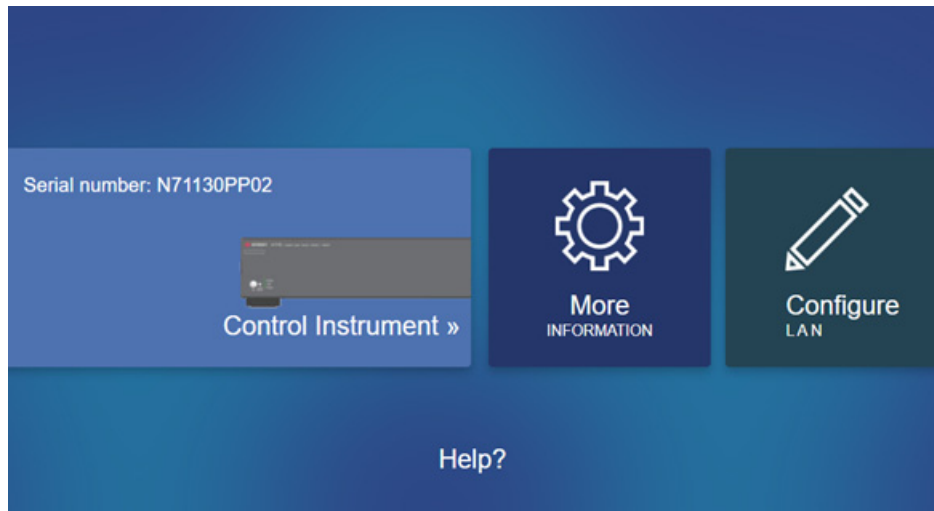

Figure 12 N777-C Instrument User Interface

For details on the interface and how to access and use it, see [Chapter , "N777-C Instrument's Front Panel Display,"](#) on page 97.

Figure 13 shows the web interface of the N777-C (Option D00) non-display instruments where the user interface can be used in a web browser on your computer.

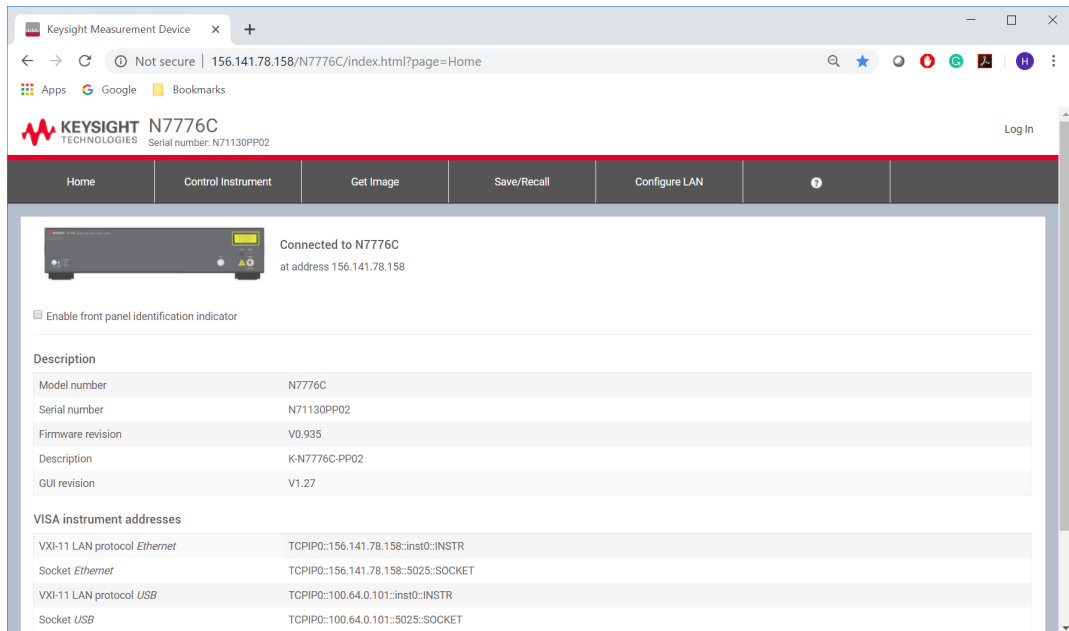

Figure 13 N777-C Web Interface

For details on the web interface and how to use it, see [Chapter , “N777-C Web Interface Reference,”](#) on page 67.

3 Definition of Terms

General Definitions	/ 52
Absolute wavelength accuracy (continuous sweep mode)	/ 53
Absolute wavelength accuracy (stepped mode)	/ 53
Dynamic power reproducibility (continuous sweep mode)	/ 53
Dynamic relative power flatness (continuous sweep mode)	/ 54
Effective linewidth	/ 54
Linewidth	/ 55
Maximum output power	/ 55
Mode-hop free tunability	/ 56
Operating temperature and humidity	/ 56
Output isolation	/ 56
Polarization extinction ratio	/ 56
Power flatness versus wavelength	/ 57
Power linearity	/ 58
Power repeatability	/ 58
Power stability	/ 59
Relative intensity noise (RIN)	/ 59
Relative wavelength accuracy (continuous sweep mode)	/ 60
Relative wavelength accuracy (stepped mode)	/ 60
Return loss	/ 61
Side-mode suppression ratio	/ 61
Signal to source spontaneous emission (SSE) ratio	/ 62
Signal to total source spontaneous emission ratio	/ 63
Wavelength range	/ 63
Wavelength repeatability (continuous sweep mode)	/ 63
Wavelength repeatability (stepped mode)	/ 64
Wavelength resolution	/ 65
Wavelength stability	/ 65

Definition of Terms

This section defines terms that are used in this document and in the data sheet.

Measurement principles are indicated. Alternative measurement principles of equal value are also acceptable.

General Definitions

Constant Temperature

Where required, is a stable operating temperature within ± 1 K.

Logged wavelength

This is the wavelength measured and recorded by the internal wavelength meter during a sweep at the corresponding trigger signal. This recorded wavelength can be read with the logging function.

NOTE

The logged wavelength positions during a sweep depend on environmental conditions and may differ slightly between repeated sweeps.

Stepped mode

In stepped mode the tunable laser source is operated statically, so that a user's measurement is made at a fixed wavelength of the tunable laser source. When tuning to a new wavelength, the static specifications are valid after completion of the tuning operation.

Continuous sweep mode

In continuous sweep mode the tunable laser source is operated dynamically, so that a user's measurement is made while the wavelength of the tunable laser source changes in a defined way (given by start wavelength, end wavelength and sweep speed). During a continuous sweep the dynamic specifications and the "Logged wavelength" apply.

Absolute wavelength accuracy (continuous sweep mode)

The maximum difference between the “Logged wavelength” and the actual wavelength in “Continuous sweep mode”. Wavelength is defined as wavelength in vacuum.

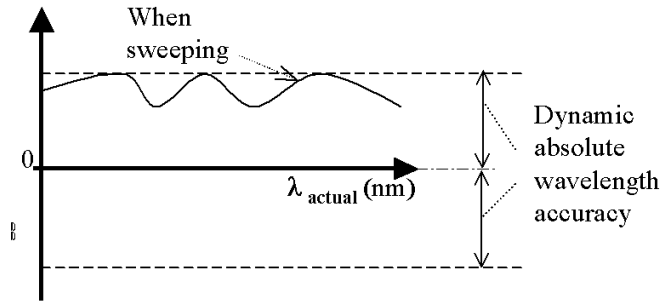

Figure 14 Absolute wavelength accuracy (continuous sweep mode)

Conditions: As specified. No mode-hop.

Absolute wavelength accuracy (stepped mode)

The maximum difference between the displayed wavelength and the actual wavelength of the tunable laser source. Wavelength is defined as wavelength in vacuum.

Conditions: Constant power level. Other conditions as specified.

Measurement: Using a wavelength meter, averaging time ≥ 1 s.

Dynamic power reproducibility (continuous sweep mode)

Specifies the random uncertainty in reproducing the output power at the same actual wavelength in different sweeps. It is expressed as \pm half the span between the maximum and minimum of all actual output powers.

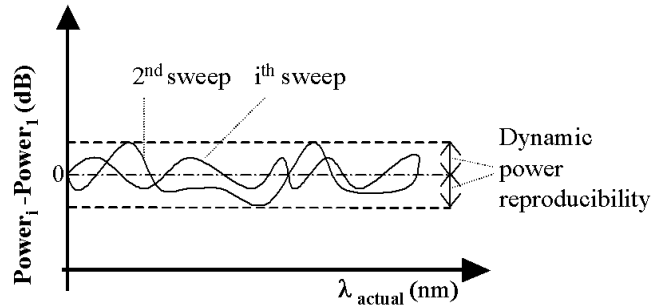

Figure 15 Dynamic power reproducibility (continuous sweep mode)

Conditions: Uninterrupted tunable laser source output power, constant temperature, no mode-hop. Other conditions as specified.

Dynamic relative power flatness (continuous sweep mode)

The high frequency part of the dynamic power flatness, obtainable by referencing the power measured at high sweep speed to the power measured at low sweep speed.

Conditions: Uninterrupted tunable laser source output power, constant power setting, constant temperature, no mode-hop. Other conditions as specified.

Measurement: Reference sweep speed value 0.5 nm/s.

Effective linewidth

The time-averaged 3 dB width of the optical spectrum, expressed in Hertz.

Conditions: Coherence control on. Other conditions as specified.

Measurement: *Using a heterodyning technique:* The output of the laser under test is mixed with another laser of the same type on a wide bandwidth photo-detector. The electrical noise spectrum of the photo-detector current is measured with a Lightwave signal analyzer, and the line-width calculated from the heterodyne spectrum. (Lightwave signal analyzer settings: resolution bandwidth 1 MHz, video bandwidth 10 kHz, sweep time 20 ms, single scan).

Linewidth

The 3 dB width of the optical spectrum, expressed in Hertz.

Conditions: Coherence control off. Other conditions as specified.

Measurement: *Using a self-heterodyning technique:* The output of the laser under test is sent through a Mach-Zehnder interferometer in which the length difference of the two arms is longer than the coherence length of the laser. The electrical noise spectrum of the photo-detector current is measured using a Lightwave signal analyzer or Keysight Optical Modulation Analyzer, and the linewidth calculated from the heterodyne spectrum.

Alternatively, *Using a heterodyning technique:* The output of the laser under test is mixed on a wide bandwidth photo-detector with another laser of the same type or with a laser with a line-width much lower than the laser to be measured. The electrical noise spectrum of the photo-detector current is measured using a Lightwave signal analyzer or Keysight Optical Modulation Analyzer, and the linewidth calculated from the heterodyne spectrum.

Maximum output power

The maximum achievable output power of the tunable laser source and the maximum output power for which the tunable laser source specifications apply.

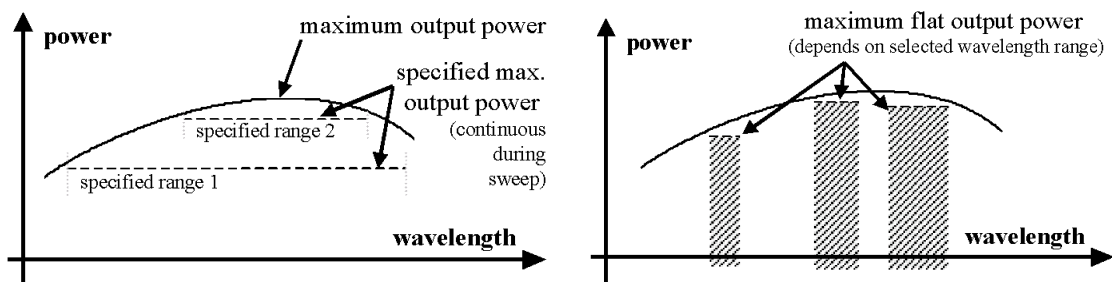

Figure 16 Maximum Output Power vs Wavelength, Maximum Flat Output Power vs Wavelength

Conditions: As specified.

Measurement: Using a power meter at the end of a 2 m single-mode fiber patchcord.

Mode-hop free tunability

Specifies the wavelength range for which no abrupt wavelength change occurs in **Stepped mode**.

Operating temperature and humidity

The ambient temperature range and humidity range of the tunable laser source for which the specifications apply.

NOTE

If the instrument is rack-mounted, the temperature and humidity within the rack apply.

Output isolation

The insertion loss of the built-in isolator in the backward direction.

Measurement: This characteristic cannot be measured from outside the instrument. It is based on known isolator characteristics.

Polarization extinction ratio

Specifies the ratio of the optical power in the slow axis of a connected polarization-maintaining fiber to optical power in the fast axis, expressed in dB

Measurement: Using a polarization analyzer at the end of a polarization-maintaining patchcord, by sweeping the wavelength to create circular traces on the Poincaré sphere. Calculate the polarization extinction ratio from the diameters of these circles.

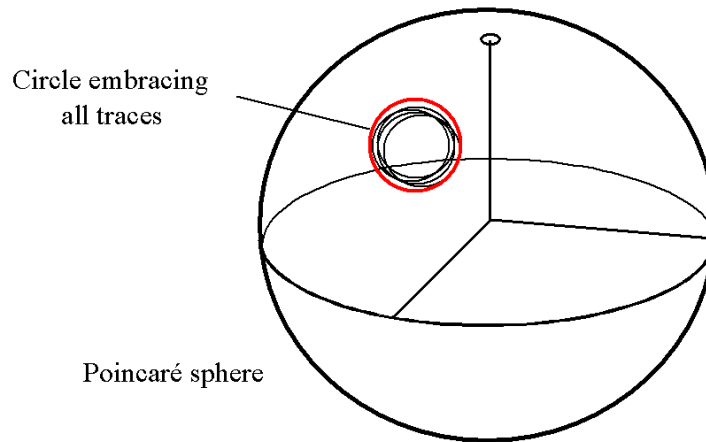

Figure 17 Circular traces on the Poincaré sphere used to calculate polarization extinction ratio.

Power flatness versus wavelength

Specifies \pm half the span (in dB) between the maximum and the minimum actual power levels of the tunable laser source when changing the wavelength.

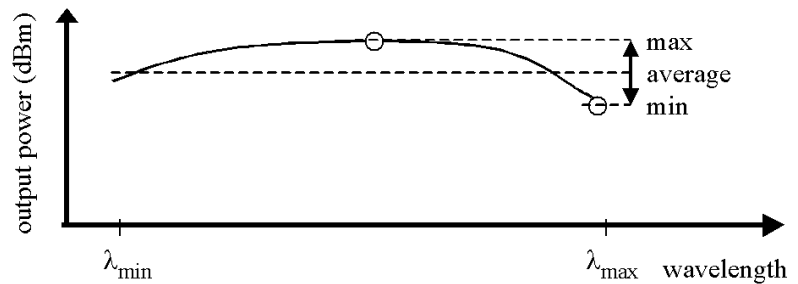

Figure 18 Power flatness vs. wavelength.

Conditions: Uninterrupted tunable laser source output power, constant power setting, constant temperature. Other conditions as specified.

Power linearity

When measuring the ratios (in dB) between the displayed power level and the actual power level for different output power levels of the tunable laser source, the power linearity is \pm half the difference between the maximum and the minimum value of all ratios.

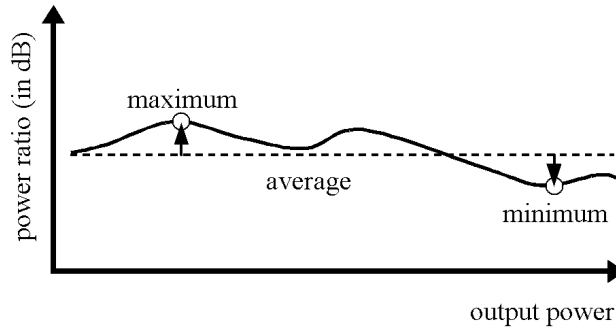

Figure 19 Power linearity.

Conditions: Uninterrupted tunable laser source output power, constant wavelength setting, constant temperature. Other conditions as specified.

Power repeatability

The uncertainty in reproducing the power level after changing and re-setting the power level. The power repeatability is \pm half the span between the highest and lowest actual power.

Conditions: Uninterrupted tunable laser source output power, constant wavelength setting, constant temperature. Other conditions as specified.

NOTE

The long-term power repeatability can be obtained by taking the power repeatability and power stability into account.

Power stability

Specifies the change of the power level of the tunable laser source over time, expressed as \pm half the span (in dB) between the highest and lowest actual power.

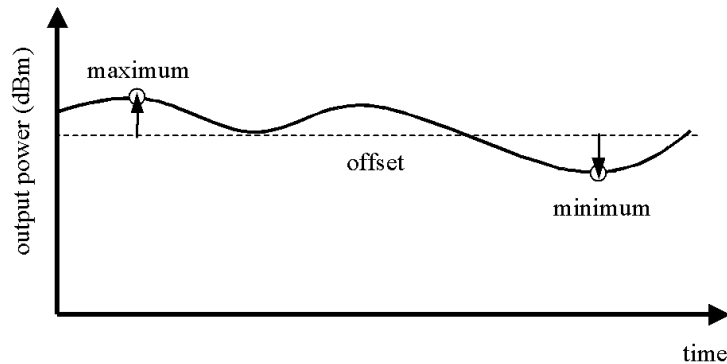

Figure 20 Power stability.

Conditions: Time span as specified. Uninterrupted tunable laser source output power, constant wavelength and power level settings, constant temperature. Other conditions as specified.

Relative intensity noise (RIN)

Specifies the ratio between the mean-square of the optical power fluctuation amplitude $\Delta P_{f,B}$ within a specified frequency range f and for bandwidth B , and the square of the average optical power P_{avg} .

$$RIN = \frac{\langle \Delta P_{f,B}^2 \rangle}{P_{\text{avg}}^2 \cdot B} \left[\frac{1}{\text{Hz}} \right]$$

RIN, if expressed as "dB/Hz", is calculated by:

$$RIN_{\text{dB/Hz}} = 10 \cdot \log \left(\frac{\Delta P_{f,B}^2 \cdot 1 \text{ Hz}}{P_{\text{avg}}^2 \cdot B} \right)$$

Conditions: As specified.

Measurement: Using a Lightwave signal analyzer and bandwidth set to 3 MHz.

Relative wavelength accuracy (continuous sweep mode)

When measuring the differences between the actual and Logged wavelength in Continuous sweep mode, the dynamic wavelength accuracy is \pm half the span between the maximum and the minimum value of all differences.

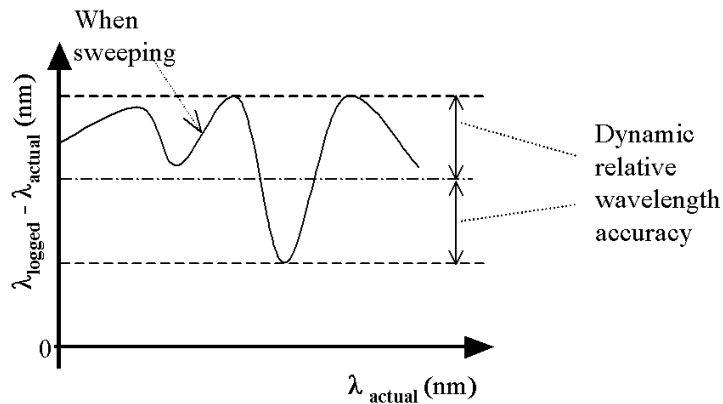

Figure 21 Relative wavelength accuracy (continuous sweep mode).

Conditions: As specified. No mode-hop.

Relative wavelength accuracy (stepped mode)

When randomly changing the wavelength and measuring the differences between the displayed and the actual wavelength, the relative wavelength accuracy is \pm half the span between the maximum and the minimum value of all differences.

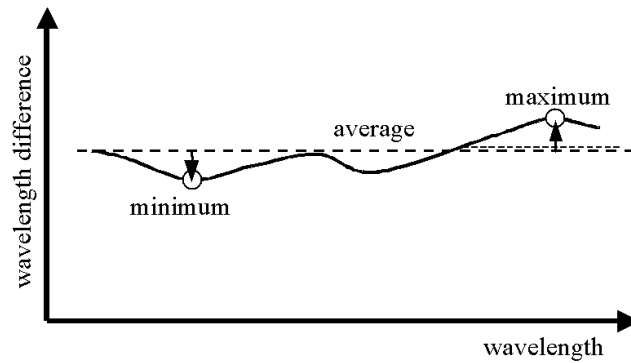

Figure 22 Relative wavelength accuracy.

Conditions: Uninterrupted tunable laser source output power, constant power setting, constant temperature. Other conditions as specified.

Measurement: Using a wavelength meter, averaging time ≥ 1 s.

Return loss

Specifies the ratio of the optical power incident to the tunable laser source output port at the wavelength set on the tunable laser source, to the power reflected from the tunable laser source output port.

Conditions: Tunable laser source output off.

Side-mode suppression ratio

The ratio of optical power in the main mode to the optical power of the highest sidemode, expressed in dB:

$$SMSR_{dB} = 10 \cdot \log \left(\frac{P_{signal}}{P_{highestsidemode}} \right)$$

Conditions: As specified.

Measurement: Using the Lightwave signal analyzer, by analyzing the heterodyning between the main signal and the highest side mode within 0.1 GHz to 6 GHz.

Signal to source spontaneous emission (SSE) ratio

Specifies the ratio between signal power and maximum spontaneous emission (SSE) power. The SSE power is determined in a specified bandwidth within a ± 3 nm window around the signal wavelength, where ± 1 nm around the signal wavelength are excluded, expressed in dB per specified bandwidth.

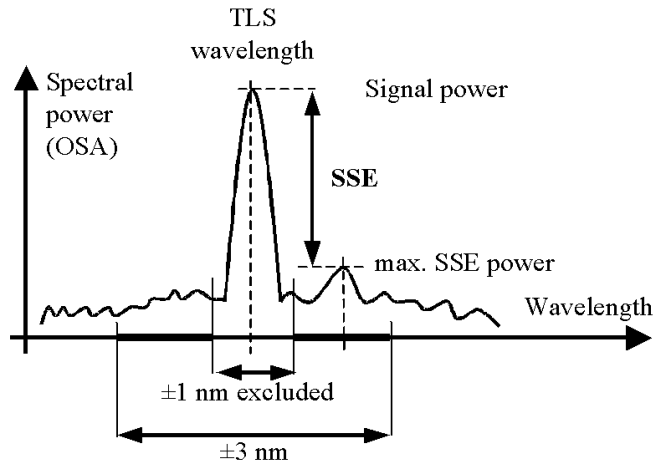

Figure 23 Signal to source spontaneous emission ratio.

Conditions: Output power as specified. Other conditions as specified.

Measurement: Using an optical spectrum analyzer (OSA) at 0.5 nm resolution bandwidth (to address the possibility of higher SSE within a narrower bandwidth), then extrapolated to 1 nm bandwidth. For the low-SSE output, if applicable, with a fiber Bragg grating inserted between the tunable laser source and the OSA to suppress the signal, thereby enhancing the dynamic range of the OSA.

Signal to total source spontaneous emission ratio

The ratio of signal power to total spontaneous emission power within, expressed in dB. The total spontaneous emission power is measured over the specified **Wavelength range**.

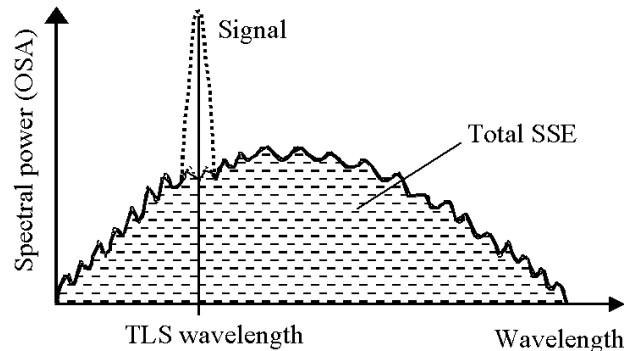

Figure 24 Signal to total source spontaneous emission ratio.

Conditions: Output power as specified. Other conditions as specified.

Measurement: Using an optical spectrum analyzer, by integrating the source spontaneous emission and excluding the remnant signal. For the low-SSE output, if applicable, with a fiber Bragg grating inserted between the tunable laser source and the OSA to suppress the signal, thereby enhancing the dynamic range of the OSA.

Wavelength range

The range of wavelengths for which the specifications apply (if not otherwise stated).

Wavelength repeatability (continuous sweep mode)

The random uncertainty of the nominal wavelength of the tunable laser source at any fixed actual wavelength in repeated sweeps. The nominal wavelength of the tunable laser source is derived from the (discrete)

Logged wavelength by interpolation. The repeatability is expressed as \pm half the span between the maximum and the minimum value of all nominal values.

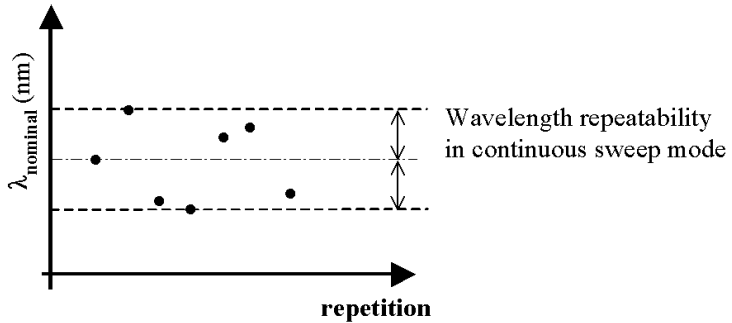

Figure 25 Wavelength repeatability (continuous sweep mode).

Conditions: As specified. No mode-hop.

Measurement: Using an optical power meter and by performing repeated spectral loss measurement on a stable absorption peak from a reference component, then analyzing the variation of the determined (interpolated) wavelength of the peak.

Wavelength repeatability (stepped mode)

The random uncertainty in reproducing a wavelength after changing and re-setting the wavelength. The wavelength repeatability is \pm half the span between the maximum and the minimum of all actual values of this wavelength.

Conditions: Uninterrupted tunable laser source output power, constant power level, constant temperature. Other conditions as specified.

Measurement: Using a wavelength meter, averaging time ≥ 1 s.

NOTE

The wavelength repeatability of the low-SSE output (if applicable) is the same as the wavelength repeatability of the high power output (guaranteed by design).

NOTE

The long-term wavelength repeatability can be obtained by taking the wavelength repeatability and wavelength stability into account.

Wavelength resolution

The smallest selectable wavelength increment or decrement.

Wavelength stability

Specifies the change of the actual wavelength of the tunable laser source over time, expressed as \pm half the span between the maximum and minimum of all wavelengths.

Conditions: Time span as specified, uninterrupted tunable laser source output power, constant wavelength and power level settings, constant temperature. Other conditions as specified.

Measurement: Using a wavelength meter, averaging time ≥ 1 s.

Keysight N777-C Series Tunable Laser Family

User's Guide

4

N777-C Web Interface Reference

[N777-C Web Interface](#) / 68

[Controlling N777-C Instruments](#) / 70

[How to Use Auxiliary Functions](#) / 84

N777-C Web Interface

Figure 26 shows the N7776C web interface with various tabs highlighted. The same web interface is applicable for N7778/79C instruments.

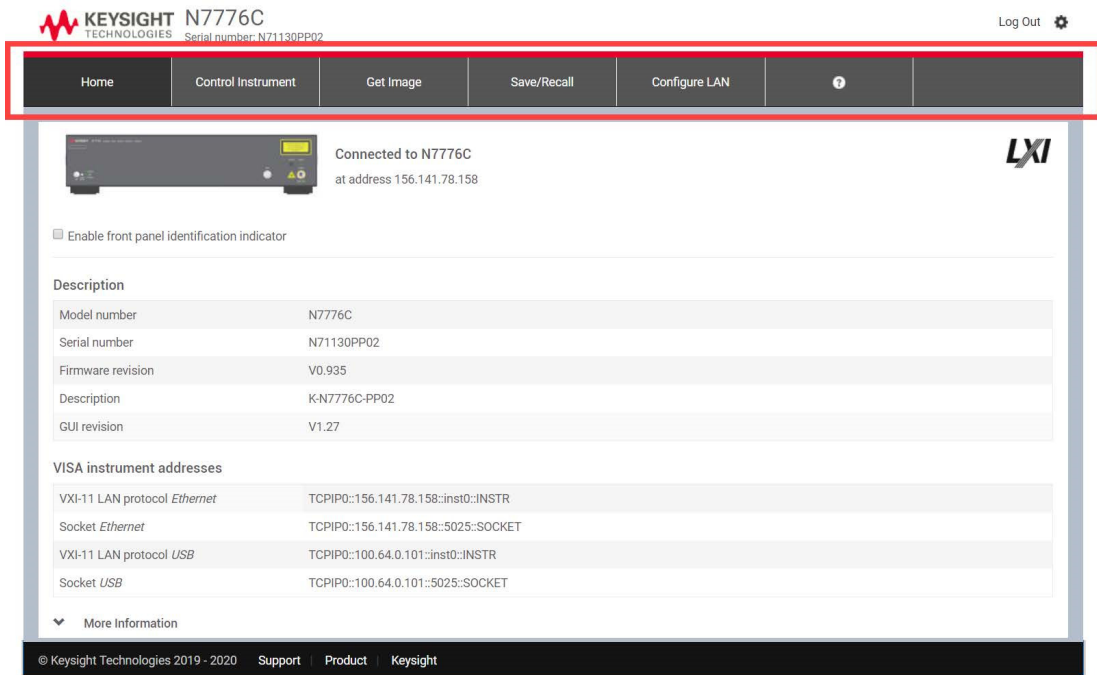

Figure 26 N7776C Web Interface

The N777-C web interface has the various tabs that help the user to control the instruments:

- **Home** – This tab displays the various instrument settings. For details, refer [How to Get Current Instrument Settings?](#) on page 84.
- **Control Instrument** – This tab allows you to set the parameters to control the instrument. For details, refer to [Controlling N777-C Instruments](#) on page 70.
- **Get Image** – This tab allows you to capture a screen of the **Control Instrument** window. The image is saved in PNG format in your PC. For details, see [How to Capture an Image of the Graph?](#) on page 85.

- **Configure LAN** – This tab displays the current LAN configuration. In addition, this tab also allows you to edit the current LAN configuration. For details, refer to [How to Configure LAN?](#) on page 94.
- **Help** – This tab opens the instrument help.

Controlling N777-C Instruments

Control Instrument Tab

The **Control Instrument** tab is used to control the N777-C instruments:

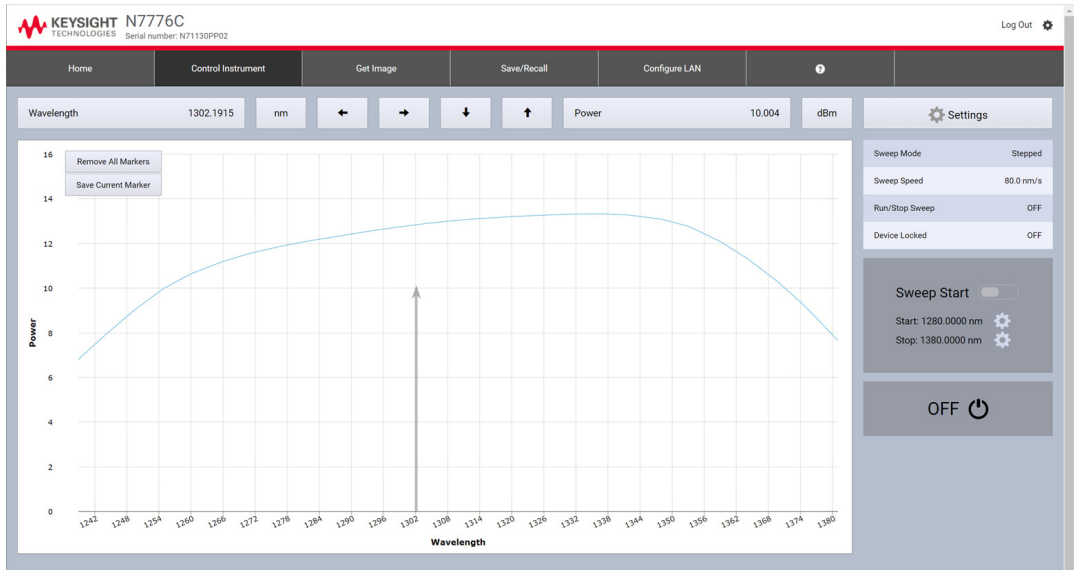

The **Control Instrument** tab provides the following features:

Display Wavelength and Power

Displays the instrument's current wavelength and power.



Changing Wavelength, Power and Units

Allows you to change the instrument's current wavelength, power and their respective units. The procedure for changing wavelength, power and their units are similar. The following example provides steps to change the wavelength and its unit.

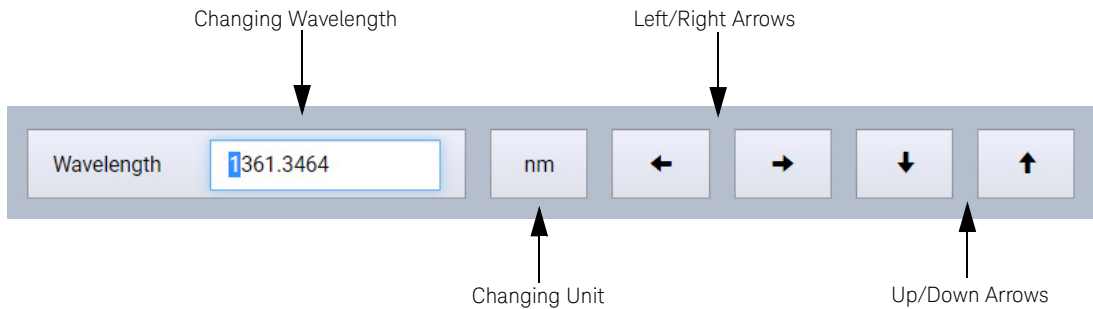

- 1 Click on the wavelength button.
- 2 Use the left or right arrows to move the position of the cursor pointer either to the left or right.
- 3 Use the up or down arrows to increase or decrease the wavelength.
- 4 Click on the unit button to change the unit. The allowed units for Wavelength are nm and THz. The allowed units for Power are mW and dBm.

Wavelength Vs. Power Graph

The **Control Instrument** tab displays a graph that shows the relationship between the wavelength and power. The power is represented by x axis while the Y axis represents the wavelength.

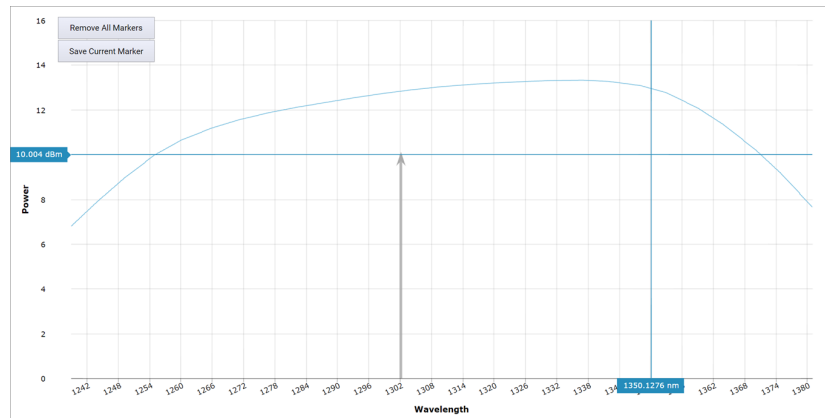

You can click on the graph to modify the wavelength and power. The blue curve on the graph denotes the excessive power curve. Setting an output power above the maximum power curve is indicated with EXP on the power display. For details, see [How to Avoid Access Power?](#) on page 74.

Working with Markers

To add a marker, double-click at a point on the graph where you want to add the marker. A small blue circle on that point denotes the marker. You are allowed to set multiple markers. Hovering the cursor over the marker causes the wavelength and power display.

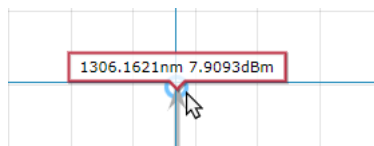

To save the marker, click on the **Save Current Markers** option.

To remove all saved markers, click on the **Remove All Marker** option.

How to set Wavelength?

How to change the Wavelength

There are three ways to set the wavelength of the Tunable Laser.

- You can set the wavelength directly on clicking the **Wavelength** button, see [Changing Wavelength, Power and Units](#) on page 71.
- You go the **Settings > Measurement Settings** and then set the wavelength, or
- You can click on the graph to set a wavelength.

Wavelength Range

Every Tunable Laser instrument has a specified wavelength range. This range is available for all Tunable Laser instruments. See the [Laser Safety Information](#) on page 15 to find your instrument's specified range.

Every Tunable Laser instrument has a permitted wavelength range. This range is greater than the specified range. The permitted wavelength range varies for each Tunable Laser instrument. You can set the wavelength to any value within the permitted wavelength range.

How to Set Power?

How to change the power

There are three ways of changing the power:

- You can set the power directly on clicking the **Power** button, see [Changing Wavelength, Power and Units](#) on page 71.
- You go the **Settings > Measurement Settings** and then set the power, or
- You can click on the graph to set a power.

How to Set the Power Unit

Pressing the unit button allows you to switch either mW or dBm as the units in which power is displayed.

What are the Power Units?

Watts (W) are the SI unit for power measurement.

You can also measure power in dBm. Values displayed in these units are derived from measurement in Watts.

By selecting dBm, the following calculation is made:

$$P_{dBm} = 10 \log \frac{P_{input}(W)}{1 \times 10^{-3}(W)}$$

Where,

P_{dBm} is the power value displayed in dBm, and

P_{input} is the input signal level in Watts.

Power, in units of dBm, is measured relative to 1 mW, it is an absolute power measurement.

How to Avoid Access Power?

If the text **EXP** is displayed in power of a Tunable Laser channel, you have set an output power level that is larger than the laser diode can produce at the selected wavelength.

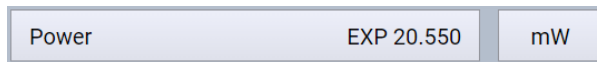

To avoid this you can:

- reduce the optical output power,
- click **Set Pmax** in the **Measurement Setting** option to select the highest permissible power for the selected.
- click **Set Pmax/Sweep** to select the highest permissible power for the selected wavelength sweep.

How to Perform a Wavelength Sweep?

What is a Wavelength Sweep?

A wavelength sweep is performed when the instrument changes the optical wavelength of the optical output across a user-defined wavelength range. You can use a wavelength sweep to measure the wavelength-dependent loss of an optical component.

How to Set the Wavelength Sweep?

The Sweep Parameters

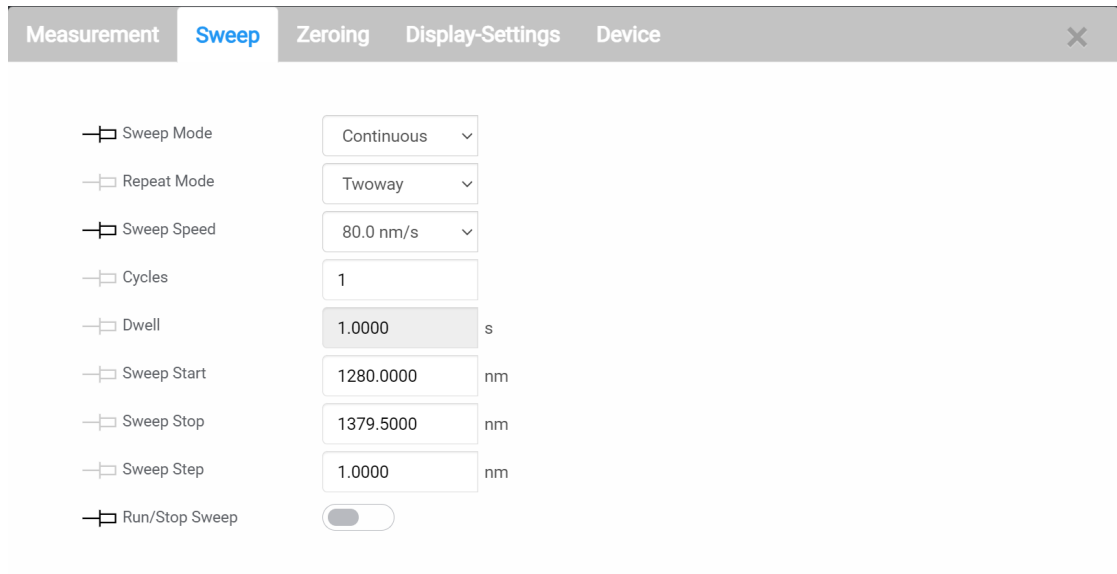

Parameter	Value	Unit
Sweep Mode	Continuous	
Repeat Mode	Tway	
Sweep Speed	80.0	nm/s
Cycles	1	
Dwell	1.0000	s
Sweep Start	1280.0000	nm
Sweep Stop	1379.5000	nm
Sweep Step	1.0000	nm
Run/Stop Sweep	<input checked="" type="checkbox"/>	

These are the parameters for the wavelength sweep:

- **Sweep Mode** - see [How to Perform a Sweep?](#) on page 77,
- **Repeat mode** - see [How to Set the Repeat Mode?](#) on page 77.
- **Sweep Speed** - the speed of a continuous sweep,
- **Cycles** - the number of times the sweep is repeated,
- **Dwell** - the amount of time spent at the wavelength during each step, for a stepped sweep
- **Sweep Start** - the wavelength at which the sweep begins,
- **Sweep Stop** - the wavelength at which the sweep ends,

- **Sweep Step** - the size of the change in the wavelength for each step of a sweep,
- **Run/Stop Sweep** - to run and start the sweep. You can also start and stop the sweep using the **Sweep Start** option preset on the **Control Instrument** tab.

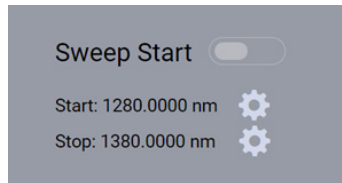

NOTE

For a Continuous sweep, Step sets the wavelength interval between output triggers, if you have set Output Trigger Mode to Step Finished, see [How to Use Output Triggering](#) on page 79.

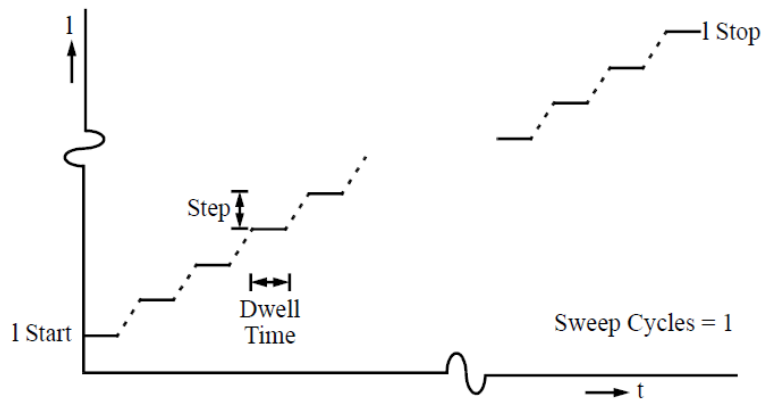

Figure 27 The Parameters for a Stepped Wavelength Sweep

How to Set the Repeat Mode?

The **Repeat Mode** determines how the instrument performs a multi-cycle sweep.

- Select **Twoway**, if you want to start every odd sweep cycle at [λ Start] and to start each even sweep cycle at [λ Stop].
- Select **Oneway**, if you want to start every sweep cycle at [λ Start] and to end every sweep cycle at [λ Stop].

Figure 28 illustrates how these modes work for a three-cycle wavelength sweep.

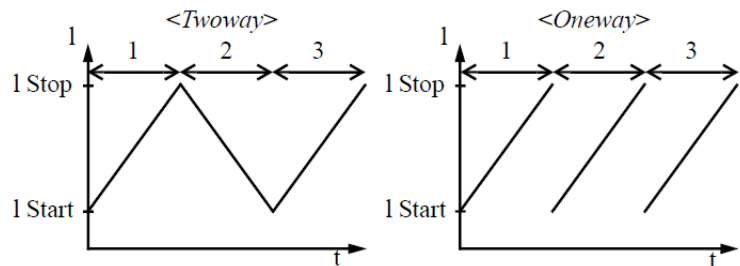

Figure 28 Repeat Modes

How to Set the Maximum Power for the Sweep Range?

Pressing **Set Pmax/Sweep** sets the power to the maximum for the selected sweep range. Pressing **Set Pmax/Sweep** ensures the power will be constant for the whole sweep.

How to Perform a Sweep?

There are three sweep modes:

- **Stepped** - which dwells at wavelengths that are separated by a certain step size,
- **Continuous** - which sweeps continually at the speed you set, and
- **Manual** - which you can run each step manually.

NOTE

You cannot turn the laser off by pressing the **Active** hardkey on the Tunable Laser front panel, while a wavelength sweep is running.

You can press **Stop** and, then, press the **Active** hardkey on the Tunable Laser front panel, to turn off the laser.

How to Use Triggers?

The N777-C Tunable Laser instruments allow you to trigger the instrument to perform tasks and to output trigger signals to external measurement instruments.

Trigger

— □ Trigger Config	Default ▾
— □ Input Trigger	Ignore ▾
— □ Output Trigger	Disabled ▾

How to Set the Trigger Configuration

The trigger level at the external trigger connectors is by default active high, this means when a trigger rises above the high TTL level (rising edge), a trigger is accepted.

You can use the **Trigger Config** drop-down menu to select the triggering mode. The following trigger configuration modes are available:

- 1 **Disabled** - select this mode if you do not want to use triggering. In this case input and output connectors are disabled.
- 2 **Default** - select this mode if you want to enable the trigger connectors. In this case input and output connectors are active.
- 3 **Passthrough** - select this mode if you want an input trigger to automatically generate an output trigger. This allows you to trigger another instrument almost simultaneously.

How to Use Input Triggering

You can configure your N777-C Tunable Laser instrument to perform certain tasks when you apply a trigger to the Input Trigger Connector.

CAUTION

A maximum of 5 V can be applied as an external voltage to the Input Trigger connector.

Do not apply an external voltage to these connectors.

To set your instrument's Input Trigger Configuration:

- 1 From the **Settings** > **Measurement Settings** and select **Trigger**.
- 2 Use the drop-down menu to select the **Input Trigger**. The following input trigger options are available:
 - **Ignore**, input triggers are ignored.
 - **Next Step**, an input trigger will cause the next step of a stepped sweep to be performed.
 - **Run Sweep**, an input trigger will start a single sweep cycle.
- 3 You can generate input triggers in any of the following ways:
 - applying a trigger to the **Input Trigger Connector** on the rear panel of your instrument,
 - setting **Trigger Configuration** to **Loopback** so that an output trigger automatically generates an input trigger, or
 - using the `:TRIGger1` command, see your *N777-C Programming Guide*.

How to Use Output Triggering

You can configure your Tunable Laser instrument to output a trigger when the instrument performs certain tasks.

To set your instrument's Output Trigger Configuration:

- 1 From the **Settings** > **Measurement Settings** and select **Trigger**.
- 2 Use the drop-down menu to select the **Output Trigger**. The following output trigger options are available:
 - **Disabled**, the output trigger mode is disabled.
 - **Step Finished**, a trigger is output after every step of a sweep finishes.
 - **Sweep Finished**, a trigger is output after a sweep cycle finishes.

- **Sweep Started**, a trigger is output after a sweep cycle starts.

NOTE

If you choose **Step Finished** and a **Continuous** sweep, the wavelength interval between hardware triggers is set by the **Step** parameter, although, the sweep is not stepped.

How to set Modulation?

The following modulation modes are available:

Modulation

Modulation

Coherence Level %

- **OFF** - No modulation
- **Coherence** - You can use coherence control to increase the line width of the optical signal output from your Tunable Laser instrument. Enabling the coherence control increases the line width of the optical output signal to between 50 and 500 MHz (typically). Coherence control greatly reduces interference effects and therefore improves the power stability in sensitive test setups. The N777-C instruments also allow adjustment of the line width broadening with the "**Coherence Level**" setting. A level of 100% corresponds to minimal broadening. The default level is usually a good setting.
- **Wavelength Locking** - You can choose wavelength locking as the modulation source, so the change in output wavelength is roughly proportional to the voltage you apply to the input BNC connector on the front panel of your Tunable Laser instrument. This enables you to fine tune the output wavelength within a limited wavelength range.

Wavelength locking may exhibit some hysteresis effects. The wavelength change may differ slightly when you increase voltage from when you decrease voltage.

If you modulate the input signal, the amplitude of the wavelength change of the modulated optical output reduces with increasing modulation frequency.

How to Lock/Unlock the Instrument?

Locking the instrument avoids to turn on the laser of the tunable laser instruments. This helps in avoiding accidents that are caused due to laser. To lock a device;

- 1 On the **Control Instrument** page, click to **Settings > Measurement Settings** and then go to **Device Locked** option.
- 2 Click on the **Device Locked** button the lock or unlock the device.



NOTE

Please note that when the device is locked, you are not able to open the device shutter or turn on the laser.

How to Turn ON/OFF the Laser?

To turn ON/OFF the laser;

- 1 On the **Control Instrument** page, click to **Settings > Measurement Settings** and then go to **Shutter Open** option.
- 2 Click on the **Shutter Open** button the turn ON/OFF the high-power laser. Ensure that your device is unlocked.

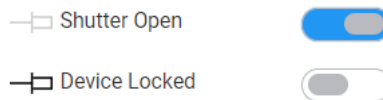

- 3 Additionally, you can also click on the **Laser ON/OFF** button available on the **Control Instrument** page.



How to Apply Display Settings?

The **Display-Settings** tab allows you to perform the following operations:

- Download PMax curve
- Update Rate

To perform a display settings:

- 1 On the **Control Instruments** tab, click on the **Settings** button.
- 2 On the **Settings** window click the **Display-Settings** tab. The following screen will appear:

The screenshot shows the 'Display-Settings' tab selected in a navigation bar. Below the tab, there are two main sections:

- Download PMax curve:** Contains a button labeled 'Export PMax curve'.
- Update Rate:** Contains a descriptive text: 'Define, after which time all settings should be fetched from device and how often the settings for the arrow should be fetched. Please note, it will only affect current session'. Below this are two input fields: 'Settings Refresh Rate' with a value of '1000' and 'ms', and 'Arrow Refresh Rate' with a value of '100' and 'ms'. A 'Save' button is located at the bottom of this section.

- 3 Perform the following operation:
 - **Download PMax curve** - Click on the **Export PMax** curve button to download the CSV file which shows the maximum achievable output power of the tunable laser source. This file will be downloaded in the "Downloads" folder.
 - **Update Rate** - For details, see [Update Rate](#) on page -92.

How to Apply Device Settings?

The **Device** tab allows you to perform the following operations:

- Realign the system
- Preset the system
- Reboot the device

To perform a **Device** setting:

- 1 On the **Control Instruments** tab, click on the **Settings** button.
- 2 On the **Settings** window click the **Device** tab. The following screen will appear:

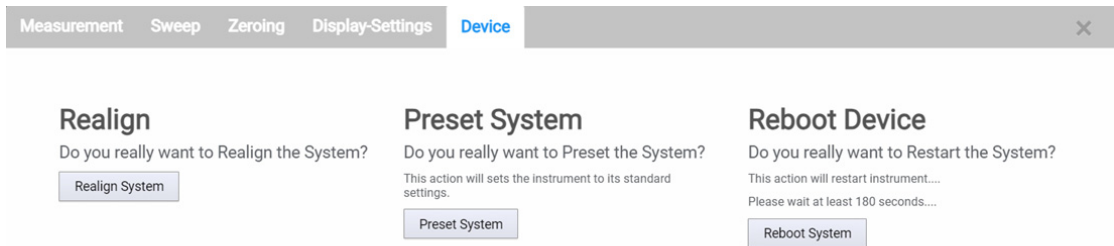

Perform the following operation:

- **Realign** - For details, see [How to Perform Realignment?](#) on page -90
- **Preset the System** - For details, see [How to Preset a Device?](#) on page -94
- **Restart the System** - For details, see [How to Reboot a Device?](#) on page -93

How to Use Auxiliary Functions

How to Get Current Instrument Settings?

The **Home** tab on the N777-C web interface displays the current instrument settings.

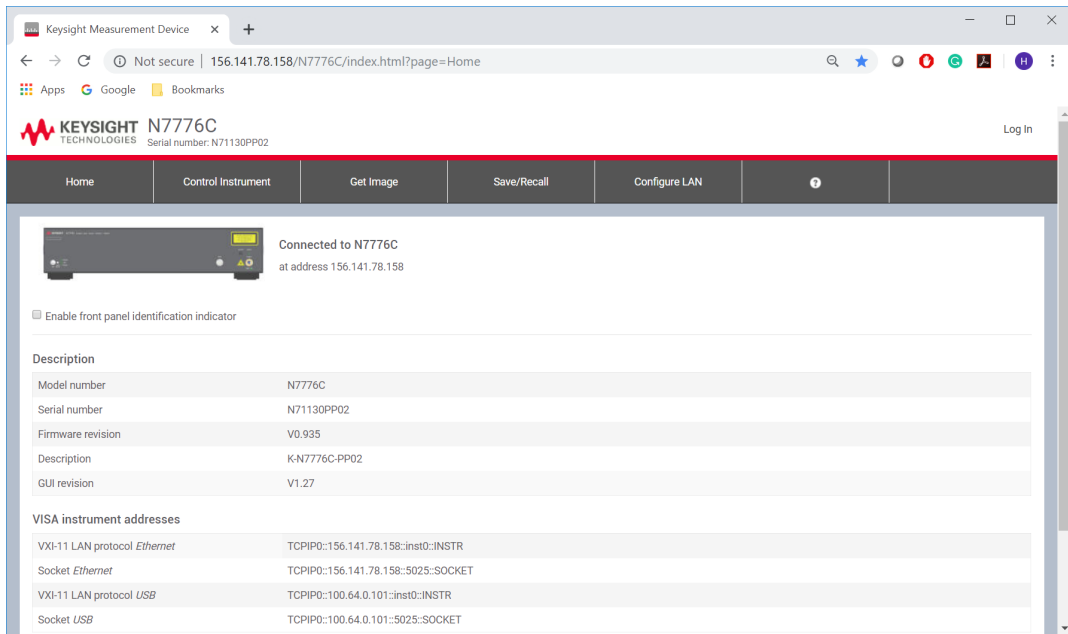

This tab displays the following settings:

- **Description** – Displays the instrument description such as instrument’s model no., serial no., firmware version and description of the current instrument.
- **VISA Instrument Address** – Displays VISA instrument addresses of the current instrument.
- **LAN Details** – Displays LAN configuration details of the current instrument.

NOTE

Please note that the **Home** tab does not allow the user to change the displayed instrument settings.

How to Identify a Particular instrument?

Sometimes, you have many instruments mounted on the rack. In this situation, it becomes difficult to identify a particular instrument which are currently connected.

To identify a particular instrument, select the check-box **Enable front panel identification indicator** available on the N777-C **Home** tab. The **Status** LED on the front panel of the connected instrument will start flashing.

Enable front panel identification indicator

How to Capture an Image of the Graph?

The **Get Image** tab on the N777-C web interface allows you to capture the current screen of the **Control Instrument** tab and save it as a PNG image. The captured image is saved in the “Downloads” folder.

NOTE

You can only capture the screen if you are in the **Control Instrument** tab.

How to Export and Import the User Interface Settings?

The **Save/Recall** tab on the N777-C web interface allows you to export and import the current user interface settings.

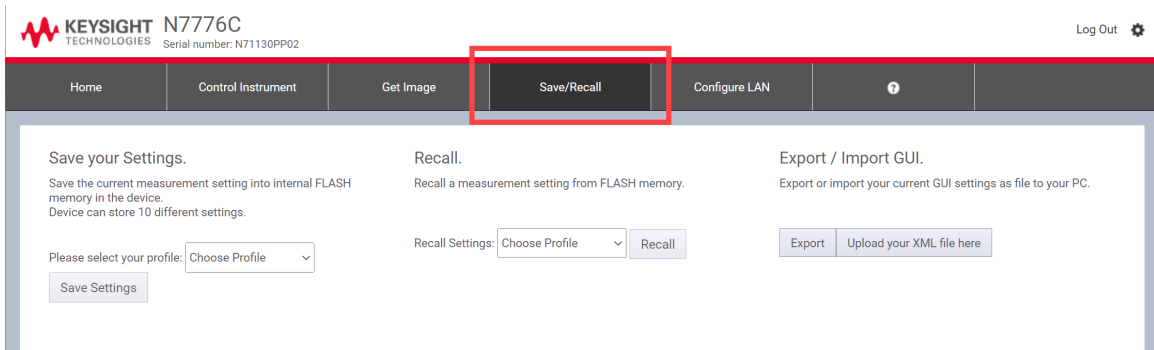

To perform the Export or Import operation:

- 1 Click on the **Save/Recall** tab.
- 2 Click the **Export** button to export the current measurement settings on your PC. The settings will be saved as XML file in your PC.
- 3 Click the **Upload your XML file here** button to import a previously saved measurement settings, A Windows **Open** dialog will appear. Locate the target file and click Open. The settings will be loaded to the instrument.

How to Save and Recall the Instrument's Measurement Settings?

The **Save/Recall** tab on the N777-C user interface allows you to save and recall the current instrument's measurement settings.

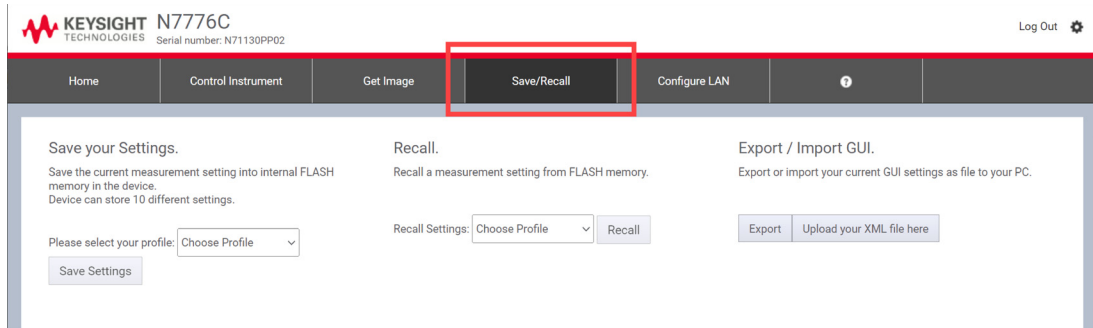

To perform the Export or Import operations:

- 1 Click on the **Save/Recall** tab.
- 2 To save the current measurement settings, select the profile from 1 to 10 and then click **Save Settings**. The current measurement setting will be saved into the internal FLASH memory in this device.
- 3 To recall the current measurement settings, select the profile from 1 to 10 and then click **Recall**. Your settings will be restored from the device flash memory.

NOTE

The last saved settings are recalled automatically after a reboot.

Logging In/Out of the N777-C Web Interface

The login screen allows the authorized users to control the N777-C instruments. When the users type in their password and click **Enter**, their credentials are validated and if correct they are logged in.

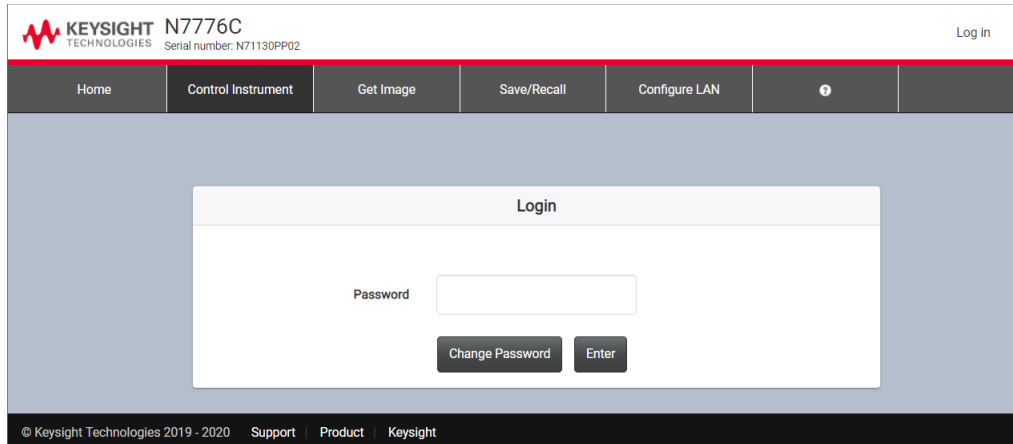

If you want to create a new password or change an existing password, click on **Change Password** button. For details, see [How to Create/Change the Password?](#) on page 89.

To log out the N777-C web interface, click on **Log out** icon available on the top right of the web interface.

Log out 

How to Create/Change the Password?

The password is used for logging in to the web page to control the N777-C instrument. To create or change a password;

- 1 Click the **Password Options** icon  available on the top right of the N777-C web interface. You see a **Change Password** box requesting you to enter the password.

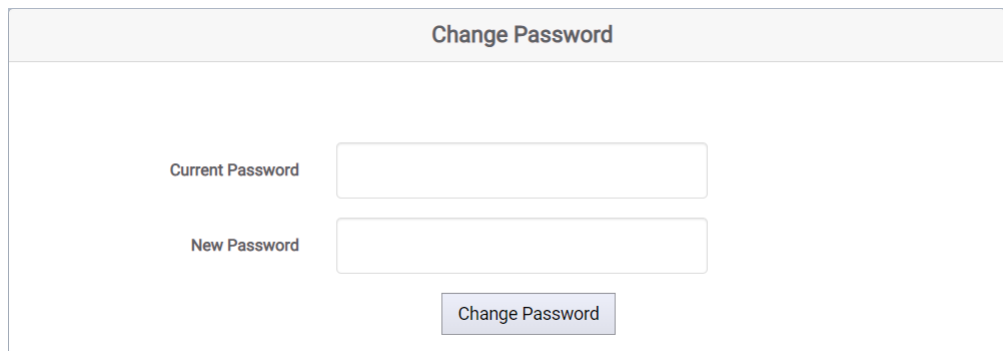

The screenshot shows a web form titled "Change Password". It contains two input fields: "Current Password" and "New Password". Below the "New Password" field is a button labeled "Change Password".

- 2 Enter the current password (the default password is blank).
- 3 Enter the new password.
- 4 Click the **Change Password** button. The password will be changed.

What If You Forget Your Password?

If you forget your password, please follow the instructions to reset the LAN button. See [The LAN Reset button](#) on page -42.

How to Perform Realignment?

Realignment realigns the laser cavity. You should use Realignment if you have already tried to reactivate the laser and to reduce power, and this has been unsuccessful.

NOTE

To get the specified performance, ensure that the warm-up time has passed before starting realignment.

To realign the laser cavity:

- 1 On the **Control Instruments** tab, go to **Settings** and then click **Device** tab. The following screen will appear:

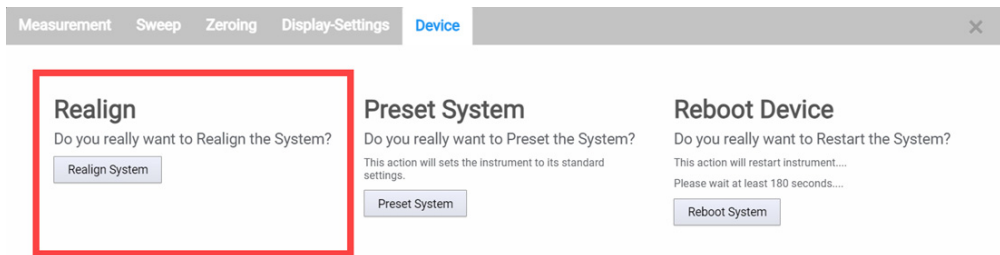

- 2 Click **Realign System** button.
- 3 Wait until the realign process completes. This process may take about 1 minute.

Lambda Zeroing

Performing a Lambda Zero re-calibrates the optical wavelength. This wavelength may drift due to a change in temperature and other environmental conditions. The regulated wavelength and wavelength logging data remain accurate, but the sweep may be offset from the intended range.

A Lambda Zero is automatically performed when the instrument boots or when an realignment is performed.

It is advisable to run this after warm-up. Also, periodic use, perhaps daily, during continuous operation or if sweeps are missing points is recommended.

To perform a wavelength zero:

- 1 On the **Control Instruments** tab, go to **Settings** and then click **Zeroing** tab. The following screen will appear:

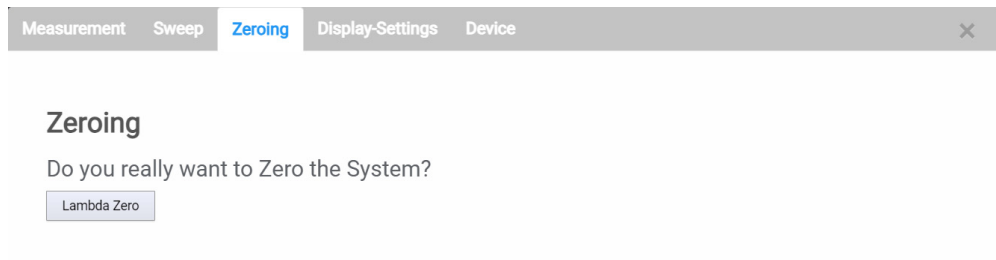

- 2 Click **Lambda Zero** button.
- 3 This proves may take several minutes. This time depends on how much the wavelength of the instrument has drifted since the last Lambda Zero was performed. Please wait until the Lambda Zeroing is completed.

Update Rate

You can use the **Update Rate** feature to set the refresh rates in milliseconds for the instrument settings and arrow used in the **Control Instrument** tab.

To perform an update rate:

- 1 On the **Control Instruments** tab, go to **Settings** and then click **Update Rate** tab. The following screen will appear

The screenshot shows a web interface with a top navigation bar containing 'Measurement', 'Sweep', 'Zeroing', 'Display-Settings', and 'Device'. The 'Display-Settings' tab is active. On the left, there is a section titled 'Download PMax curve' with an 'Export PMax curve' button. On the right, a modal dialog titled 'Update Rate' is open, highlighted with a red border. The dialog contains the following text: 'Define, after which time all settings should be fetched from device and how often the settings for the arrow should be fetched. Please note, it will only affect current session'. Below this, there are two input fields: 'Settings Refresh Rate' with a value of '1000' and 'ms' to its right, and 'Arrow Refresh Rate' with a value of '100' and 'ms' to its right. At the bottom of the dialog is a 'Save' button.

- 2 Enter the new refresh rates in milliseconds for the instrument settings and arrow.
- 3 Click on **Save** button.

NOTE

The new refresh rates will only be effective for the current session.

How to Reboot a Device?

An instrument reboot is required if it becomes unresponsive or returns errors. To perform a reboot:

- 1 On the **Control Instruments** tab, go to **Settings** and then click **Device** tab. The following screen will appear:

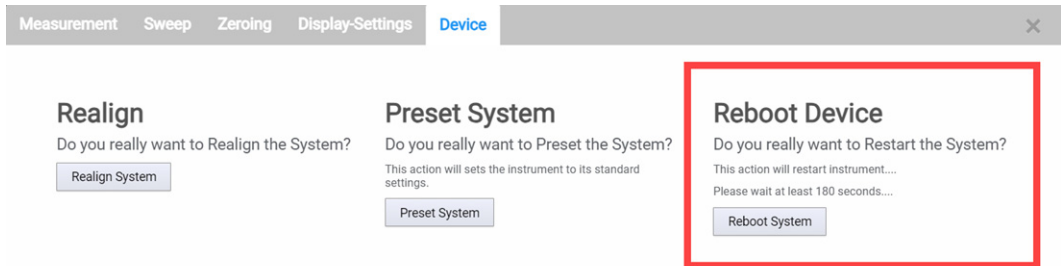

- 2 Click on the **Reboot System** button. This action will restart the instrument and take at least 180 seconds. Please wait until the reboot process is completed.

NOTE

Please save your settings before you reboot the instrument else all your current settings will be lost. See [How to Save and Recall the Instrument's Measurement Settings?](#) on page -87.

How to Preset a Device?

The preset option is required to set the instrument to its default settings.

To perform a preset:

- 1 On the **Control Instruments** tab, go to **Settings** and then click **Device** tab. The following screen will appear:

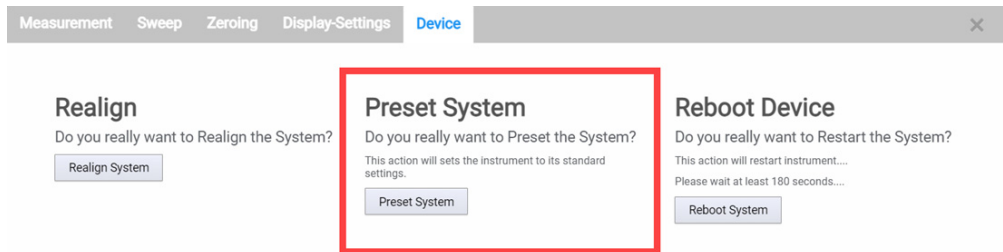

- 2 Click on the **Preset System** button. This action will preset the instrument to its default settings.

NOTE

Preset operation will delete all saved measurement settings.

How to Configure LAN?

Show the Current LAN Settings

The **Configure LAN** tab on the N777-C web interface displays the currently used LAN settings. It display the following networking parameters:

- IP address configuration
- IP address
- Subnet mask
- Default gateway
- DNS server(s)
- Hostname
- Domain

Edit LAN Settings

The **Configure LAN** tab also allows you to edit the currently used LAN settings. To do so,

- 1 Click on the **Edit** button. The **Edit Network Configuration** page will appear as shown in the figure below:

Configure LAN > Edit Network Configuration

Warning: Your connection to the instrument may be broken after executing either of the operations below. If so, reconnect to the instrument using the new hostname or IP address.

Instrument identification

Desired hostname
K-N7776C-0PP02

Description
K-N7776C-PP02

IP address configuration

Use automatic configuration

IP address
192.168.0.2

Subnet mask
255.255.255.0

Default gateway
192.168.0.1

DNS server address configuration

Use automatic configuration

Preferred DNS server

WARNING

Your connection to the instrument may be broken after executing either of the operations below. If so, reconnect to the instrument using the new hostname or IP address.

- 2 Enter the descriptions for the following LAN configuration parameters:
 - Instrument identification
 - IP address configuration
 - DNS server address configuration

NOTE

For IP address and DNS server configuration, you can select the Use Automatic Configuration check-box to automatically select the IP address and DNS server.

- Once, the changes are done, click on **Apply Changes** button.

NOTE

It can take up to 30 seconds for changes to these settings to take effect. You may need to refresh the Configure LAN page after 30 seconds to see the updated settings. Changes in host name and description require reboot or LAN restart to take effect.

Reset Network Configuration

The **Configure LAN** tab also allows you to reset all LAN parameters to the factory default. To do so;

- Click the **Advance Options** button available on **Configure LAN** tab. The **Advance Network Options** page will appear.

Configure LAN > Advance Network Options

Warning: Your browser connection to the instrument may be broken after executing either of the operations below. If so, reconnect to the instrument using the new hostname or IP address.

Reset Network Configuration

Reset all the LAN parameters to the factory default. Enables DHCP, AutoIP and reset password, description and hostname.

Reset

- Click on the **Reset** button to reset all LAN parameters to the factory default.

WARNING

Your browser connection to the instrument may be broken after executing the reset network configuration operation. If so, reconnect to the instrument using the new hostname or IP address.

Keysight N777-C Series Tunable Laser Family

User's Guide

5 N777-C Instrument's Front Panel Display

[N777-C Instrument's Front Panel Display](#) / 98

[Controlling N777-C Instruments](#) / 100

N777-C Instrument's Front Panel Display

Figure 29 shows the N777-C instrument's front panel display:

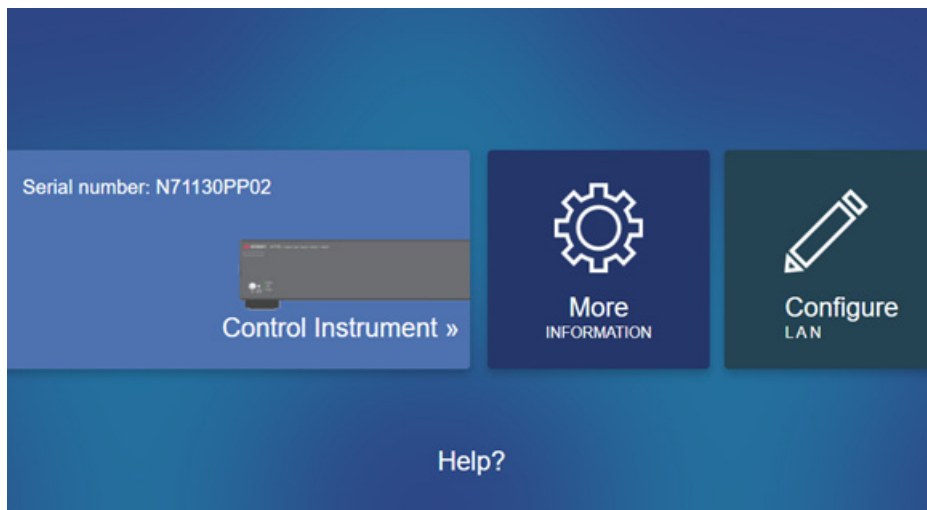

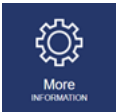

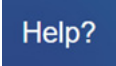



Figure 29 N7776C User Interface

The N777-C instrument's front panel provides the following elements:

Elements	Caption	Description
	Control Instrument	This button opens the Control Instrument window which allows you to set the parameters to control the instrument. For details, refer to Controlling N777-C Instruments on page 100.
	More INFORMATION	This button opens More Information window which displays the instrument settings. For details, refer How to Get Current Instrument Settings? on page 113

Elements	Caption	Description
	Configure LAN	This button opens the Configure LAN window which displays the current LAN configuration and allows you to edit the current LAN configuration. For details, refer to How to Configure LAN? on page 115
	Help	This button opens the instrument's help.
	Home	This button navigates you to the home screen (the default screen).

Controlling N777-C Instruments

Control Instrument Window

To access the instrument settings and to manually control the instrument, click **Control Instrument** present on the user interface.

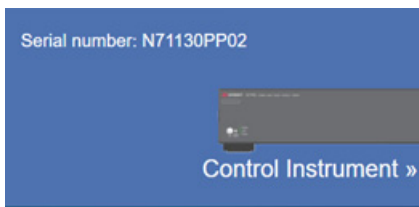

The following **Control Instrument** window will appear:

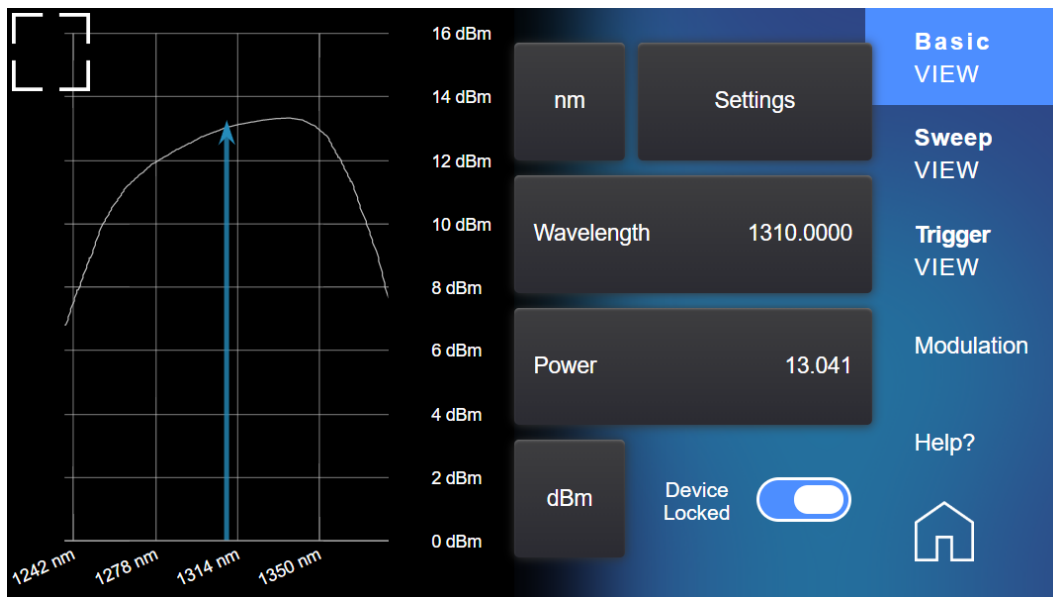

The **Control Instrument** window provides the following features:

Display Wavelength and Power

Displays the instrument's current wavelength and power.

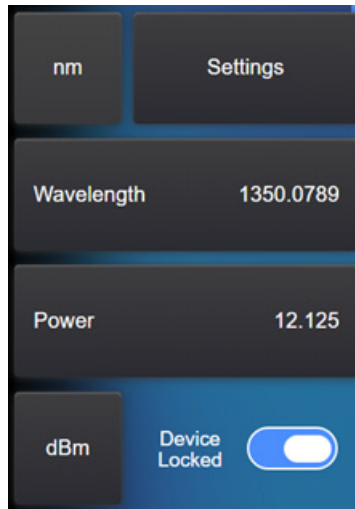

Changing Wavelength, Power and Units

Allows you to change the instrument's current wavelength, power and their respective units. The procedure for changing wavelength, power and their units are similar. The following example provides steps to change the wavelength and its unit.

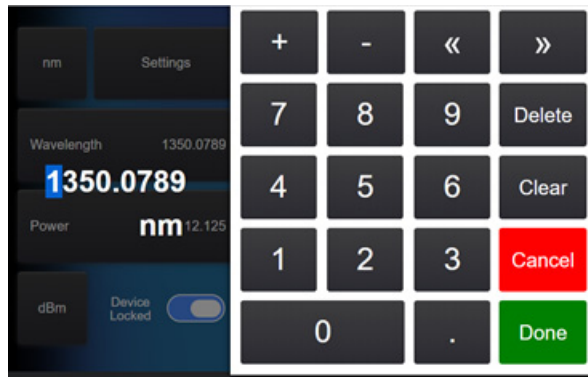



- 1 Click on the **Wavelength** button. The on-screen numeric keypad will appear. Use this keypad to enter the wavelength values.
- 2 Use the left (<<) or right (>>) arrow buttons to move the position of the cursor pointer either to the left or right.
- 3 Use the (+) or (-) buttons to increase or decrease the wavelength value.
- 4 Once done, click on Done button.
- 5 The unit button is a toggle button. Click on this button to change the unit. The allowed units for Wavelength are nm and THz. The allowed units for Power are mW and dBm.

Wavelength Vs. Power Graph

The **Control Instrument** window displays the relationship between the wavelength and power through a graph. The x-axis represents the wavelength and the Y axis represents the power.

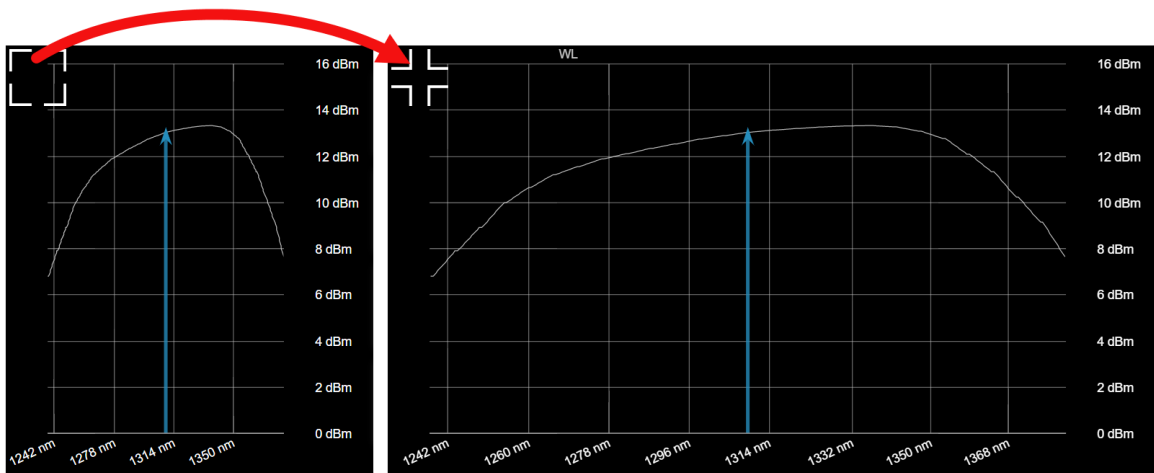
The white curve on the graph denotes the maximum power curve. Setting an output power above the maximum power curve is indicated with EXP on the power display. For details, see [How to Avoid Excessive Power?](#) on page 105



The graph also provides the zoom functionality. The  **Zoom In** button allows you to enlarge the graph on full screen to view more details.

The  **Zoom Out** button allows you to reduce the graph to its normal size.

How to set Wavelength?

How to change the Wavelength

You can set the wavelength value by directly clicking on the **Wavelength** button. For details, see [Changing Wavelength, Power and Units](#) on page 101.

Every Tunable Laser instrument has a specified wavelength range. This range is available for all Tunable Laser instruments. See the Laser Safety Information to find your instrument's specified range.

Every Tunable Laser instrument has a permitted wavelength range. This range is greater than the specified range. The permitted wavelength range varies for each Tunable Laser instrument. You can set the wavelength to any value within the permitted wavelength range.

How to Set the Wavelength Unit?

Pressing the unit button allows you to switch either nm or THz as the units in which power is displayed.

What are the Wavelength Unit?

The SI unit of wavelength measurement is meter usually denoted as m.

How to Set Power?

How to change the power

You can set the power value by directly clicking on the **Power** button. For details, see [Changing Wavelength, Power and Units](#) on page 101.

How to Set the Power Unit

Pressing the unit button allows you to switch either mW or dBm as the units in which power is displayed.

What are the Power Units?

Watts (W) are the SI unit for power measurement.

You can also measure power in dBm. Values displayed in these units are derived from measurement in Watts.

By selecting dBm, the following calculation is made:

$$P_{dBm} = 10 \log \frac{P_{input}(W)}{1 \times 10^{-3}(W)}$$

Where,

P_{dBm} is the power value displayed in dBm, and

P_{input} is the input signal level in Watts.

Power, in units of dBm, is measured relative to 1 mW, it is an absolute power measurement.

How to Avoid Excessive Power?

If the text **EXP** is displayed in power of a Tunable Laser channel, you have set an output power level that is larger than the laser diode can produce at the selected wavelength.

To avoid this you can:

- reduce the optical output power,
- click **Set P_{max}** in the **Setting** option to select the highest permissible power for the selected wavelength.
- click **Set P_{max}/Sweep** to select the highest permissible power for the selected wavelength sweep.

How to Perform a Wavelength Sweep?

What is a Wavelength Sweep?

A wavelength sweep is performed when the instrument changes the optical wavelength of the optical output across a user-defined wavelength range. You can use a wavelength sweep to measure the wavelength-dependent loss of an optical component.

How to Set the Wavelength Sweep?

The wavelength sweep can be set up through the **Sweep VIEW** tab.

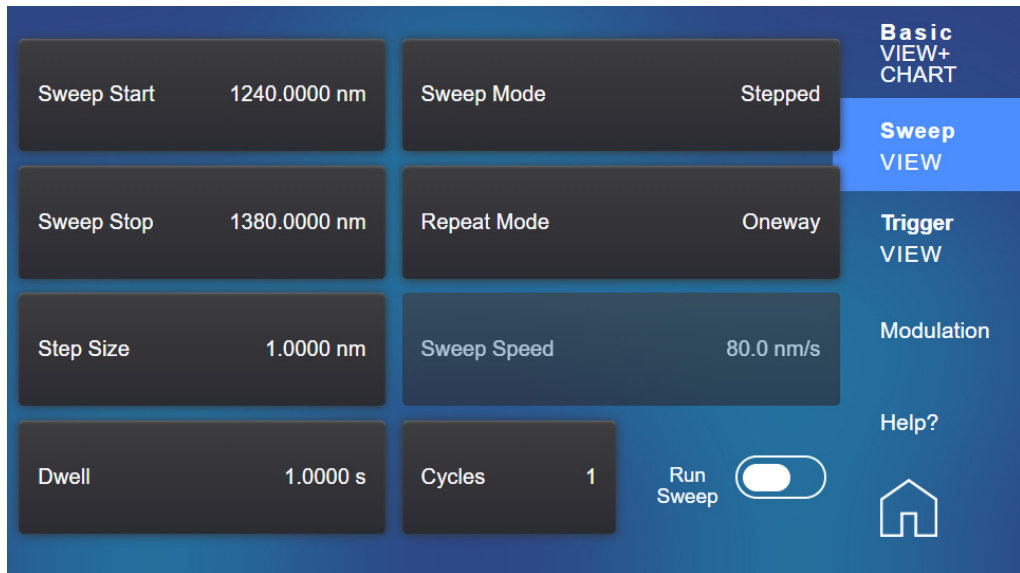

These are the parameters for the wavelength sweep:

- **Sweep Mode** - see [How to Perform a Sweep?](#) on page 108,
- **Repeat Mode** - see [How to Set the Repeat Mode?](#) on page 107,
- **Sweep Speed** - the speed of a continuous sweep,
- **Cycles** - the number of times the sweep is repeated,
- **Dwell** - the amount of time spent at the wavelength during each step, for a stepped sweep
- **Sweep Start** - the wavelength at which the sweep begins,
- **Sweep Stop** - the wavelength at which the sweep ends,
- **Sweep Step** - the size of the change in the wavelength for each step of a sweep,
- **Run/Stop Sweep** - to run and start the sweep.

NOTE

For a Continuous sweep, Step sets the wavelength interval between output triggers, if you have set Output Trigger Mode to Step Finished, see [How to Use Output Triggering](#) on page 111.

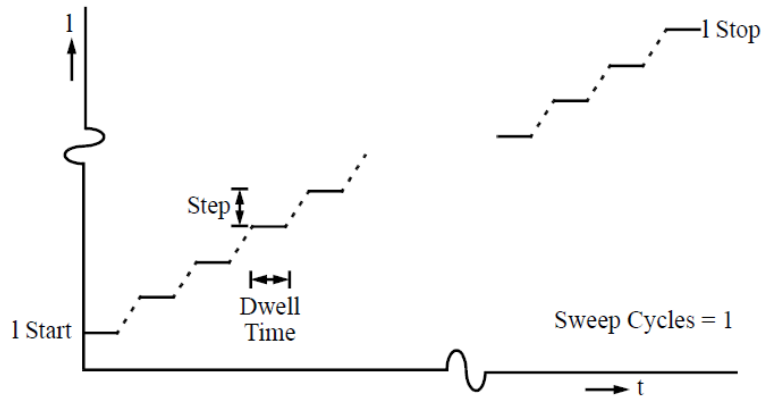

Figure 30 The Parameters for a Stepped Wavelength Sweep

How to Set the Repeat Mode?

The **Repeat Mode** determines how the instrument performs a multi-cycle sweep.

- Select **Twoway**, if you want to start every odd sweep cycle at [λ Start] and to start each even sweep cycle at [λ Stop].
- Select **Oneway**, if you want to start every sweep cycle at [λ Start] and to end every sweep cycle at [λ Stop].

Figure 31 illustrates how these modes work for a three-cycle wavelength sweep.

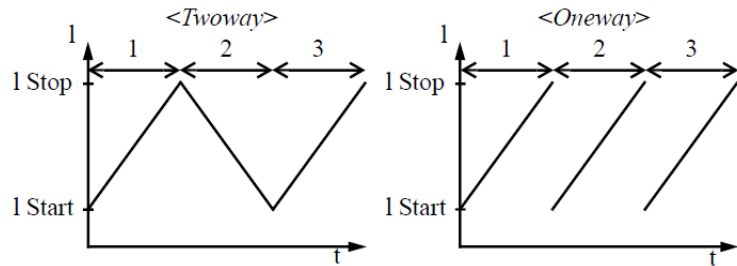

Figure 31 Repeat Modes

How to Set the Maximum Power for the Sweep Range?

Pressing **Set P_{max}/Sweep** sets the power to the maximum for the selected sweep range. Pressing **Set P_{max}/Sweep** ensures the power will be constant for the whole sweep.

How to Perform a Sweep?

There are three sweep modes:

- **Stepped** - which dwells at wavelengths that are separated by a certain step size,
- **Continuous** - which sweeps continually at the speed you set, and
- **Manual** - which you can run each step manually.

NOTE

You cannot turn the laser off by pressing the **Active** hardkey on the Tunable Laser front panel, while a wavelength sweep is running.

You can press **Stop Sweep** and, then, press the **Active** hardkey on the Tunable Laser front panel, to turn off the laser.

How to Use Triggers?

The N777-C Tunable Laser instruments allow you to trigger the instrument to perform tasks and to output trigger signals to external measurement instruments.

To view the **Trigger** window, click on the **Trigger VIEW** tab. The following window appears:

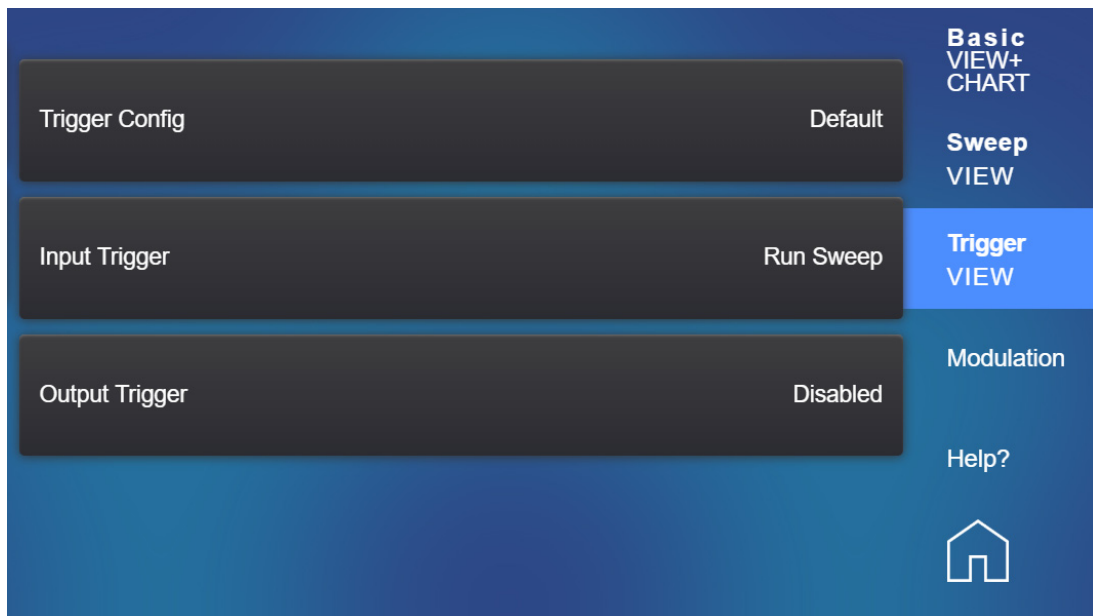

How to Set the Trigger Configuration

The trigger level at the external trigger connectors is by default active high, this means when a trigger rises above the high TTL level (rising edge), a trigger is accepted.

You can use the **Trigger Config** drop-down menu to select the triggering mode.

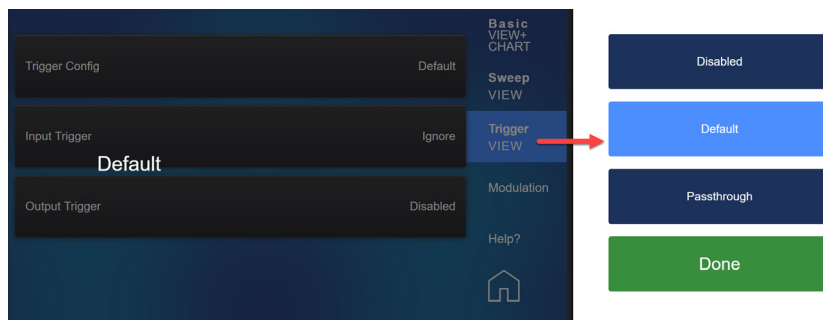

The following trigger configuration modes are available:

- 1 **Disabled** - select this mode if you do not want to use triggering. In this case input and output connectors are disabled.
- 2 **Default** - select this mode if you want to enable the trigger connectors. In this case input and output connectors are active.
- 3 **Passthrough** - select this mode if you want an input trigger to automatically generate an output trigger. This allows you to trigger another instrument almost simultaneously.

How to Use Input Triggering

You can configure your N777-C Tunable Laser instrument to perform certain tasks when you apply a trigger to the Input Trigger Connector.

CAUTION

A maximum of 5 V can be applied as an external voltage to the Input Trigger connector.

Do not apply an external voltage to these connectors.

To set your instrument's Input Trigger Configuration:

- 1 From the **Control Instrument** window, click **Trigger VIEW** tab.
- 2 Use the menu to select the **Input Trigger**. The following input trigger options are available:
 - **Ignore**, input triggers are ignored.
 - **Next Step**, an input trigger will cause the next step of a stepped sweep to be performed.
 - **Run Sweep**, an input trigger will start a single sweep cycle.

- 3 You can generate input triggers in any of the following ways:
 - applying a trigger to the **Input Trigger Connector** on the rear panel of your instrument,
 - setting **Trigger Configuration** to **Loopback** so that an output trigger automatically generates an input trigger, or
 - using the `:TRIGger1` command, see your *N777-C Programming Guide*.

How to Use Output Triggering

You can configure your Tunable Laser instrument to output a trigger when the instrument performs certain tasks.

To set your instrument's Output Trigger Configuration:

- 1 From the **Control Instrument** window, click **Trigger VIEW** tab.
- 2 Use the menu to select the **Output Trigger**. The following output trigger options are available:
 - **Disabled**, the output trigger mode is disabled.
 - **Step Finished**, a trigger is output after every step of a sweep finishes.
 - **Sweep Finished**, a trigger is output after a sweep cycle finishes.
 - **Sweep Started**, a trigger is output after a sweep cycle starts.

NOTE

If you choose **Step Finished** and a **Continuous** sweep, the wavelength interval between hardware triggers is set by the **Step** parameter, although, the sweep is not stepped.

How to set Modulation?

To view the **Modulation** window, click on the **Modulation** tab. The following window appears:

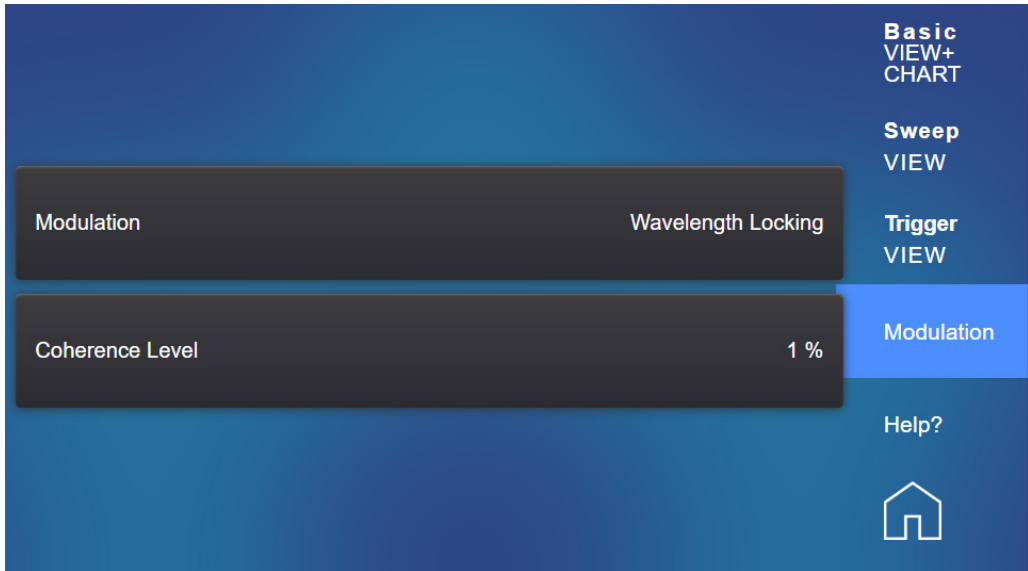

The following modulation modes are available:

- **OFF** - No modulation
- **Coherence** - You can use coherence control to increase the line width of the optical signal output from your Tunable Laser instrument.
 Enabling the coherence control increases the line width of the optical output signal to between 50 and 500 MHz (typically). Coherence control greatly reduces interference effects and therefore improves the power stability in sensitive test setups.
 The N777-C instruments also allow adjustment of the line width broadening with the "**Coherence Level**" setting. A level of 100% corresponds to minimal broadening. The default level is usually a good setting.
- **Wavelength Locking** - You can choose wavelength locking as the modulation source, so the change in output wavelength is roughly proportional to the voltage you apply to the input BNC connector on the front panel of your Tunable Laser instrument. This enables you to fine tune the output wavelength within a limited wavelength range.

Wavelength locking may exhibit some hysteresis effects. The wavelength change may differ slightly when you increase voltage from when you decrease voltage.

If you modulate the input signal, the amplitude of the wavelength change of the modulated optical output reduces with increasing modulation frequency.

How to Lock/Unlock the Instrument?

Locking the instrument avoids to turn on the laser of the tunable laser instruments. This helps in avoiding accidents that are caused due to laser.

To lock an instrument, go to the Control Instrument window and click the Device Locked button to either lock or unlock the instrument.

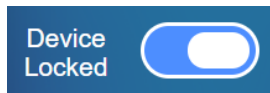

NOTE

Please note that you will be not able to open the device shutter or turn on the laser until the device is locked.

How to Turn ON/OFF the Laser Output?

To turn ON/OFF the laser output, press the On/Off button available on the front panel of the instrument.

How to Get Current Instrument Settings?

You can get the currently used LAN settings through the **More INFORMATION** window. To open this window, click on the **More INFORMATION** button available on the N777-C user interface.

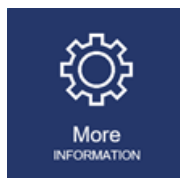

The **More INFORMATION** window displays the current settings:

Description		LAN Details	
Model number:	N7776C	DNS hostname	K-N7776C-0PP02
Serial number:	N71130PP02	mDNS hostname	K-N7776C-0PP02.local
Firmware revision:	V1.000	IPv4 address	156.141.78.158
Description:	K-N7776C-PP02	Ethernet (MAC) address	80-09-02-08-02-5c
GUI revision:	V1.46	Auto-MDIX capable	Yes
VISA instrument addresses			
VXI-11 LAN protocol <i>Ethernet</i> :		TCPIP0::156.141.78.158::inst0::INSTR	
Socket <i>Ethernet</i> :		TCPIP0::156.141.78.158::5025::SOCKET	
VXI-11 LAN protocol <i>USB</i> :		TCPIP0::100.64.0.101::inst0::INSTR	
Socket <i>USB</i> :		TCPIP0::100.64.0.101::5025::SOCKET	



This window displays the following settings:

- **Description** – Displays the instrument description such as instrument's model no., serial no., firmware version and description of the current instrument.
- **VISA Instrument Address** – Displays VISA instrument addresses of the current instrument.
- **LAN Details** – Displays LAN configuration details of the current instrument.

How to Configure LAN?

You can configure LAN setting through the **Configure LAN** window. To open the **Configure LAN** window, click on the **Configure LAN** button.



The **Configure LAN** window displays the currently used LAN settings.

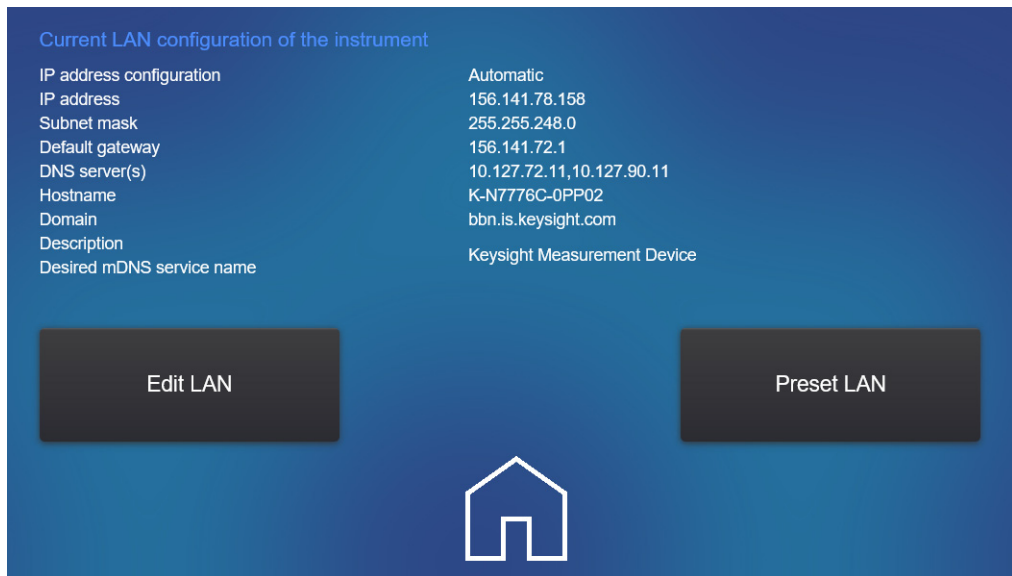

It display the following networking parameters:

- IP address configuration
- IP address
- Subnet mask
- Default gateway
- DNS server(s)
- Hostname
- Domain

Edit LAN Settings

The **Configure LAN** window also allows you to edit the currently used LAN settings. To do so, click on the **Edit LAN** button.

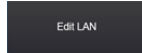

The **Edit** dialog will appear as shown in the figure below:

 A dark-themed dialog box titled "Edit". It contains a checkbox labeled "Use automatic configuration" which is checked. Below this are three input fields: "IP address" with the value "192.168.0.2", "Subnet mask" with the value "255.255.255.0", and "Default gateway" with the value "192.168.0.1". At the bottom, there are two buttons: "Apply Changes" and "Cancel". A small note at the bottom of the dialog reads: "Note: It can take up to 30 seconds for changes to these settings to take effect. You may need to refresh the Configure LAN page after 30 seconds to see the updated settings. Changes in hostname and description require reboot or LAN restart to take effect."

This dialog allows you to edit the following LAN configuration parameters:

- Select the **“Use automatic configuration”** checkbox if you want to the system to use the automatic configuration.
- Unselect the **“Use automatic configuration”** checkbox if you want to provide some other configuration.
- Enter the descriptions for the following LAN configuration parameters:
 - IP Address
 - Subnet Mask
 - Default Gateway
- Once done, click **Apply Changes** button for these settings to take effect.

NOTE

It can take up to 30 seconds for changes to these settings to take effect. You may need to refresh the **Configure LAN** page after 30 seconds to see the updated settings. Changes in hostname and description require reboot or LAN restart to take effect.

WARNING

Your connection to the instrument may be broken after executing either of the operations below. If so, reconnect to the instrument using the new hostname or IP address.

Preset LAN Settings

The Configure LAN window also allows you to preset the LAN settings to the factory default. To do so, click the Preset LAN button.

A dark gray rectangular button with the text "Preset LAN" centered in white.**NOTE**

This process might take up to 30 seconds for the changes to take effect.

WARNING

Your browser connection to the instrument may be broken after executing the reset network configuration operation. If so, reconnect to the instrument using the new hostname or IP address.

6 Maintenance

[Cleaning Instructions](#) / 120

[Further Cleaning Information](#) / 124

[Firmware Upgrades](#) / 125

[Contact Keysight Technologies](#) / 126

Cleaning Instructions

The following Cleaning Instructions contain some general safety precautions, which must be observed during all phases of cleaning. Consult your specific optical device manuals or guides for full information on safety matters.

Please try, whenever possible, to use physically contacting connectors, and dry connections. Clean the connectors, interfaces, and bushings carefully after use.

If you are unsure of the correct cleaning procedure for your optical device, we recommend that you first try cleaning a dummy or test device.

Keysight Technologies assume no liability for the customer's failure to comply with these requirements.

Safety Precautions

Please follow the following safety rules:

- Do not remove instrument covers when operating.
- Ensure that the instrument is switched off throughout the cleaning procedures.
- To prevent electrical shock, disconnect the instrument from the mains before cleaning. Use a dry cloth, or one slightly dampened with water, to clean the external case parts. Do not attempt to clean internally.
- After cleaning, do not switch on the instrument when there is no termination to the optical output connector, to the optical fiber or to the attached device. The laser radiation is not visible to the human eye, but it can seriously damage your eyesight.

Why is it important to clean optical devices?

In transmission links optical fiber cores are about 9 mm (0.00035") in diameter. Dust and other particles, however, can range from tenths to hundredths of microns in diameter. Their comparative size means that they can cover a part of the end of a fiber core, and as a result will reduce the performance of your system.

Furthermore, the power density may burn dust into the fiber and cause additional damage (for example, 0 dBm optical power in a single mode fiber causes a power density of approximately 16 million W/m²). If this happens, measurements become inaccurate and non-repeatable.

Before you make any connection you must ensure that all cables and connectors are clean. If they are dirty, use the appropriate cleaning procedure.

When inserting the ferrule of a patchcord into a connector or an adapter, make sure that the fiber end does not touch the outside of the mating connector or adapter. Otherwise you will rub the fiber end against an unsuitable surface, producing scratches and dirt deposits on the surface of your fiber.

What materials do I need for proper cleaning?

Some **Standard Cleaning Equipment** on page 121 is necessary for cleaning your instrument.

Standard Cleaning Equipment

Before you can start your cleaning procedure you need the following standard equipment:

- Dust and shutter caps
- Isopropyl alcohol
- Cotton swabs
- Soft tissues
- Compressed air

Dust and shutter caps

All of Keysight Technologies' lightwave instruments are delivered with either laser shutter caps or dust caps on the lightwave adapter. All cables come with covers to protect the cable ends from damage or contamination.

We suggest these protected coverings should be kept on the equipment at all times, except when your optical device is in use. Be careful when reattaching dust caps after use. Do not press the bottom of the cap onto the fiber too hard, as any dust in the cap can scratch or pollute your fiber surface.

Isopropyl alcohol

This solvent is usually available from any local pharmaceutical supplier or chemist's shop.

If possible avoid using denatured alcohol containing additives. Instead, apply alcohol used for medical purposes.

Never try to drink this alcohol, as it may seriously damage to your health.

Do not use any other solvents, as some may damage plastic materials and claddings. Acetone, for example, will dissolve the epoxy used with fiber optic connectors. To avoid damage, only use isopropyl alcohol.

If you use isopropyl alcohol to clean your optical device, do not immediately dry the surface with compressed air. This is because the dust and the dirt is solved and will leave behind filmy deposits after the alcohol is evaporated. You should therefore first remove the alcohol and the dust with a soft tissue, and then use compressed air to blow away any remaining filaments.

Cotton swabs

We recommend that you use cotton swabs available from local distributors of medical and hygiene products.

Ensure that you use natural cotton swabs. Foam swabs will often leave behind filmy deposits after cleaning.

Use care when cleaning, and avoid pressing too hard onto your optical device with the swab. Too much pressure may scratch the surface, and could cause your device to become misaligned. It is advisable to rub gently over the surface using only a small circular movement.

Swabs should be used straight out of the packet, and never used twice. This is because dust and dirt in the atmosphere, or from a first cleaning, may collect on your swab and scratch the surface of your optical device.

Soft tissues

These are available from most stores and distributors of medical and hygiene products.

We recommend that you do not use normal cotton tissues, but multi-layered soft tissues made from non-recycled cellulose. Cellulose tissues are very absorbent and softer. Consequently, they will not scratch the surface of your device over time.

Use care when cleaning, and avoid pressing on your optical device with the tissue. Pressing too hard may lead to scratches on the surface or misalignment of your device. Just rub gently over the surface using a small circular movement.

Use only clean, fresh soft tissues and never apply them twice. Any dust and dirt from the air which collects on your tissue, or which has gathered after initial cleaning, may scratch and pollute your optical device.

Compressed air

Compressed air can be purchased from any laboratory supplier.

It is essential that your compressed air is free of dust, water and oil. Only use clean, dry air. If not, this can lead to filmy deposits or scratches on the surface of your connector. This will reduce the performance of your transmission system.

When spraying compressed air, hold the can upright. If the can is held at a slant, propellant could escape and dirty your optical device. First spray into the air, as the initial stream of compressed air could contain some condensation or propellant. Such condensation leaves behind a filmy deposit.

Cleaning Instrument Housings

Use a dry and very soft cotton tissue to clean the instrument housing. Do not open the instruments as there is a danger of electric shock, or electrostatic discharge. Opening the instrument can cause damage to sensitive components, and in addition your warranty will be voided.

General Cleaning Procedure

Light dirt

If you just want to clean away light dirt, observe the following procedure for all devices:

- Use compressed air to blow away large particles.
- Clean the device with a dry cotton swab.
- Use compressed air to blow away any remaining filament left by the swab.

Heavy Dirt

Use this procedure particularly when there is greasy dirt on the connector:

- 1 Moisten a new cotton-swab with isopropyl alcohol.
- 2 Clean the connector by rubbing the cotton-swab over the surface using a small circular movement.
- 3 Take a new, dry soft-tissue and remove the alcohol, dissolved sediment and dust, by rubbing gently over the surface using a small circular movement.
- 4 Blow away any remaining lint with compressed air.

Further Cleaning Information

For further information on cleaning and safety matters for optical devices, refer the following document:

<https://www.keysight.com/us/en/assets/7018-08610/configuration-guides/5989-4473.pdf>

Firmware Upgrades

This section provides information about the firmware upgrade process for the N777-C series tunable laser instruments.

You may need to upgrade firmware:

- To enhance the usability and functionality of your instrument. New features may be available with new firmware revisions.

Firmware updates can be done by installing the firmware updates installation file, which can be downloaded from www.keysight.com.

CAUTION

Ensure to execute the firmware update procedure only under conditions of reliable power and I/O connectivity to the instrument. For example, do not update firmware with an intermittent LAN connection, a loose power cord, or during a thunderstorm that may interrupt power. Loss of power or connectivity may cause the firmware update fail, possibly making instrument non-operational.

NOTE

Updating the firmware will not affect your annual instrument calibration.

Requirements

To upgrade firmware for the N777-C series tunable laser instruments, you require a PC, running Windows 10 on it.

To update the firmware you need to download the current firmware which consist of two components:

- Firmware Upload Utility
- The latest firmware version (*.bin file)

NOTE

This process could take a couple of minutes (5-10 minutes depending on your network speed).

Once you have copied both items to your computer, proceed as follows:

- 1 Run the **Firmware Update Utility** and select the device you want to update.
- 2 Browse to the location of the firmware that you just downloaded and open the file.
- 3 Press **Start**.

The update utility will copy the firmware update file on your local PC.

After the firmware has been updated, the instrument will automatically restart itself with the new software

During the update process the Status and the Active LED will flash periodically.

- 4 Check the firmware version. Go to instrument's user interface Home tab and check for the firmware version.

Contact Keysight Technologies

To locate a sales or service office near you, go to www.keysight.com/find/contactus.



This information is subject to
change without notice.
© Keysight Technologies 2024
Edition 3.1, February 2024



N7770-90B02

www.keysight.com