

Keysight U7233A/U7233B DDR1 Compliance Test Application

Compliance Testing
Notes

Notices

© Keysight Technologies 2015 - 2017

No part of this manual may be reproduced in any form or by any means (including electronic storage and retrieval or translation into a foreign language) without prior agreement and written consent from Keysight Technologies as governed by United States and international copyright laws.

Manual Part Number

U7233-97002

Edition

Fifth Edition, April 2017

Printed in Malaysia

Keysight Technologies.
1900 Garden of the Gods Road
Colorado Springs, CO 80907 USA

Warranty

THE MATERIAL CONTAINED IN THIS DOCUMENT IS PROVIDED "AS IS," AND IS SUBJECT TO BEING CHANGED, WITHOUT NOTICE, IN FUTURE EDITIONS. FURTHER, TO THE MAXIMUM EXTENT PERMITTED BY APPLICABLE LAW, KEYSIGHT DISCLAIMS ALL WARRANTIES, EITHER EXPRESS OR IMPLIED WITH REGARD TO THIS MANUAL AND ANY INFORMATION CONTAINED HEREIN, INCLUDING BUT NOT LIMITED TO THE IMPLIED WARRANTIES OF MERCHANTABILITY AND FITNESS FOR A PARTICULAR PURPOSE. KEYSIGHT SHALL NOT BE LIABLE FOR ERRORS OR FOR INCIDENTAL OR CONSEQUENTIAL DAMAGES IN CONNECTION WITH THE FURNISHING, USE, OR PERFORMANCE OF THIS DOCUMENT OR ANY INFORMATION CONTAINED HEREIN. SHOULD KEYSIGHT AND THE USER HAVE A SEPARATE WRITTEN AGREEMENT WITH WARRANTY TERMS COVERING THE MATERIAL IN THIS DOCUMENT THAT CONFLICT WITH THESE TERMS, THE WARRANTY TERMS IN THE SEPARATE AGREEMENT WILL CONTROL.

Technology Licenses

The hardware and/or software described in this document are furnished under a license and may be used or copied only in accordance with the terms of such license.

Restricted Rights Legend

If software is for use in the performance of a U.S. Government prime contract or subcontract, Software is delivered and licensed as "Commercial computer software" as defined in DFAR 252.227-7014 (June 1995), or as a "commercial item" as defined in FAR 2.101(a) or as "Restricted computer software" as defined in FAR 52.227-19 (June 1987) or any equivalent agency regulation or contract clause. Use, duplication or disclosure of Software is subject to Keysight Technologies' standard commercial license terms, and non-DOD Departments and Agencies of the U.S. Government will receive no greater than Restricted Rights as defined in FAR 52.227-19(c)(1-2) (June 1987). U.S. Government users will receive no greater than Limited Rights as defined in FAR

52.227-14 (June 1987) or DFAR 252.227-7015 (b)(2) (November 1995), as applicable in any technical data.

Safety Notices

CAUTION

A CAUTION notice denotes a hazard. It calls attention to an operating procedure, practice, or the like that, if not correctly performed or adhered to, could result in damage to the product or loss of important data. Do not proceed beyond a CAUTION notice until the indicated conditions are fully understood and met.

WARNING

A WARNING notice denotes a hazard. It calls attention to an operating procedure, practice, or the like that, if not correctly performed or adhered to, could result in personal injury or death. Do not proceed beyond a WARNING notice until the indicated conditions are fully understood and met.

Quick Reference

Table 1 Cycles and Signals

NOTE: 1 = Single Ended probing; 2 = Differential probing; 3 = 2 x Single Ended probing

TEST	Cycle		Based on Test Definition						Required to Perform on Scope						Opt.
	Read	Write	DQ	DQS	CK	ADD	Ctrl	Data Mask Ctrl	DQ	DQS	CK	ADD	Ctrl	Data Mask Ctrl	CS#
SlewR		√	√	√	√	√	√	√	√ ²	√ ²	√ ²	√ ²	√ ²	√ ²	
SlewF		√	√	√	√	√	√	√	√ ²	√ ²	√ ²	√ ²	√ ²	√ ²	
VIH(ac)		√	√	√	√	√	√	√	√ ²	√ ²	√ ²	√ ²	√ ²	√ ²	
VIH(dc)		√	√	√	√	√	√	√	√ ²	√ ²	√ ²	√ ²	√ ²	√ ²	
VIL(ac)		√	√	√	√	√	√	√	√ ²	√ ²	√ ²	√ ²	√ ²	√ ²	
VIL(dc)		√	√	√	√	√	√	√	√ ²	√ ²	√ ²	√ ²	√ ²	√ ²	
VOH(ac)		√	√	√	√	√	√	√	√ ²	√ ²	√ ²	√ ²	√ ²	√ ²	
VOL(ac)		√	√	√	√	√	√		√ ²	√ ²	√ ²	√ ²	√ ²		
AC Overshoot		√	√	√	√	√	√	√	√ ²	√ ²	√ ²	√ ²	√ ²	√ ²	
AC Undershoot		√	√	√	√	√	√	√	√ ²	√ ²	√ ²	√ ²	√ ²	√ ²	
VID(ac)		√		√	√					√ ³	√ ³				
VIX(ac)		√		√	√					√ ³	√ ³				
tAC	√		√		√				√ ²	√ ²	√ ²				√
tDQSCK	√			√	√				√ ²	√ ²	√ ²				√
tCK(avg)					√						√ ²				
tCH(avg)					√						√ ²				
tCL(avg)					√						√ ²				
tHZ(DQ)	√		√		√				√ ²	√ ²	√ ²				√
tHZ(DQS)	√			√	√				√ ²	√ ²	√ ²				√
tLZ(DQS)	√			√	√				√ ²	√ ²	√ ²				√
tLZ(DQ)	√		√		√				√ ²	√ ²	√ ²				√
tDQSQ	√		√	√					√ ²	√ ²	√ ²				√
tQH	√		√	√					√ ²	√ ²	√ ²				√
TEST	Cycle		Based on Test Definition						Required to Perform on Scope						Opt.

Table 1 Cycles and Signals

NOTE: 1 = Single Ended probing; 2 = Differential probing; 3 = 2 x Single Ended probing

	Read	Write	DQ	DQS	CK	ADD	Ctrl	Data Mask Ctrl	DQ	DQS	CK	ADD	Ctrl	Data Mask Ctrl	CS#
tDQSS		√		√	√				√ ²	√ ²	√ ²				√
tDQSH	√			√					√ ²	√ ²	√ ²				√
tDQSL	√			√					√ ²	√ ²	√ ²				√
tDSS		√		√	√				√ ²	√ ²	√ ²				√
tDSH		√		√	√				√ ²	√ ²	√ ²				√
tWPST		√		√					√ ²	√ ²	√ ²				√
tWPRE		√		√					√ ²	√ ²	√ ²				√
tRPRE	√			√					√ ²	√ ²	√ ²				√
tRPST	√			√					√ ²	√ ²	√ ²				√
tDS(base)		√	√						√ ²	√ ²	√ ²				√
tDH(base)		√	√						√ ²	√ ²	√ ²				√
tIS(base)	√				√	√	√				√ ²	√ ²	√ ²		√
tIH(base)	√				√	√	√				√ ²	√ ²	√ ²		√
High State Ringing			√	√		√	√	√	√ ^{1,2}	√ ^{1,2}		√ ^{1,2}	√ ^{1,2}	√ ^{1,2}	
Low State Ringing			√	√		√	√	√	√ ^{1,2}	√ ^{1,2}		√ ^{1,2}	√ ^{1,2}	√ ^{1,2}	
tJIT(per)					√						√ ²				
tJIT(cc)					√						√ ²				
tERR(nper)					√						√ ²				
tJIT(duty)					√						√ ²				

DDR1 Compliance Test Application – At A Glance

The Keysight U7233A/U7233B DDR1 Compliance Test Application is a DDR (Double Data Rate) test solution that covers electrical, clock and timing parameters of the JEDEC (Joint Electronic Device Engineering Council) specifications, specifically *JESD79E*. The software helps you in testing all the un-buffered device under test (DUT) compliance, with the Keysight 54850A, 8000 and 80000 and 90000A series Infiniium digital storage oscilloscope.

There are 2 main categories of test modes:

- Compliance Tests - These tests are based on the DDR JEDEC compliance specifications and are compared to corresponding compliance test limits.
- Debug Mode - These tests are not based on any compliance specification. The primary use of these tests is to perform signal debugging.

The DDR1 Compliance Test Application:

- Lets you select individual or multiple tests to run.
- Lets you identify the device being tested and its configuration.
- Shows you how to make oscilloscope connections to the device under test.
- Automatically checks for proper oscilloscope configuration.
- Automatically sets up the oscilloscope for each test.
- Allows you to determine the number of trials for each test, with the new multi trial run capability.
- Provides detailed information of each test that has been run. The result of maximum twenty five worst trials can be displayed at any one time.
- Creates a printable HTML report of the tests that have been run.

The minimum number of probes required for the tests are:

- Clock tests - 1 probe.
- Electrical tests - 3 probes.
- Clock Timing tests - 3 probes.
- Advanced Debug tests - 3 probes.

NOTE

The tests performed by the DDR1 Compliance Test Application are intended to provide a quick check of the physical layer performance of the DUT. These tests are not replacement for an exhaustive test validation plan.

DDR SDRAM electrical, clock and timing test standards and specifications are described in the *JESD79E* document. For more information, please refer to JEDEC web site at www.jedec.org.

Required Equipment and Software

In order to run the DDR1 automated tests, you need the following equipment and software:

- 54850A, 8000, 80000 or 90000A series Infiniium Digital Storage Oscilloscope. Keysight recommends using 4 GHz and higher bandwidth oscilloscope.
- Infiniium software revision 05.30 or later (54850A, 8000 and 80000 series Infiniium Digital Storage Oscilloscope) OR
- Baseline software revision 1.0 (90000A series Infiniium Digital Storage Oscilloscope).
- U7233A/U7233B DDR1 Compliance Test Application, version 1.20 and higher.
- RAM reliability test software.
- 1169A, 1168A, 1134A, 1132A or 1131A InfiniiMax probe amplifiers.
- N5381A or E2677A differential solder-in probe head, N5382A or E2675A differential browser probe head, N5425A ZIF probe head or N5426A ZIF tips.
- Any computer motherboard system that supports memory.
- Keyboard, qty = 1, (provided with the Keysight Infiniium oscilloscope).
- Mouse, qty = 1, (provided with the Keysight Infiniium oscilloscope).

Below are the required licenses:

- U7233A/U7233B DDR1 Compliance Test Application license.
- N5414A InfiniiScan software license (for 90000A, 80000 and 54850A series).
- N5415A InfiniiScan software license (for 8000 series).
- N5404A Deep memory option (optional).

In This Book

This manual describes the tests that are performed by the DDR1 Compliance Test Application in more detail; it contains information from (and refers to) the *JESD79E*, and it describes how the tests are performed.

- **Chapter 1**, “Installing the DDR1 Compliance Test Application shows how to install and license the automated test application software (if it was purchased separately).
- **Chapter 2**, “Preparing to Take Measurements shows how to start the DDR1 Compliance Test Application and gives a brief overview of how it is used.
- **Chapter 3**, “Single-Ended Signals AC Input Parameters Tests shows how to run the single-ended signals AC input parameters tests. This chapter includes maximum ac output logic high and minimum ac output logic low.
- **Chapter 4**, “Single-Ended Signals AC Output Parameters Tests shows how to run the single-ended signals AC output parameters tests. This chapter includes input logic high tests, input logic low tests, and maximum and minimum ac output logic high and low.
- **Chapter 5**, “Single-Ended Signals Overshoot/Undershoot Tests describes the AC overshoot and undershoot tests probing and method of implementation.
- **Chapter 6**, “Differential Signals AC Input Parameters Tests describes the V_{ID} AC differential input voltage tests and V_{IX} AC differential cross point voltage tests.
- **Chapter 8**, “Clock Timing (CT) Tests describes the clock timing operating conditions of SDRAM as defined in the specification.
- **Chapter 7**, “Data Strobe Timing (DST) Tests describes various data strobe timing tests including $t_{HZ}(DQ)$, $t_{HZ}(DQS)$, $t_{LZ}(DQS)$, $t_{LZ}(DQ)$, t_{DQSQ} , t_{QH} , t_{DQSS} , t_{DQSH} , t_{DQSL} , t_{DSS} , t_{DSH} , t_{WPST} , t_{WPRE} , t_{RPRE} and t_{RPST} tests.
- **Chapter 9**, “Data Mask Timing (DMT) Tests describes the DQ and DM input setup time and input hold time.
- **Chapter 10**, “Command and Address Timing (CAT) Tests describes the address and control input setup time and input hold time.
- **Chapter 11**, “Advanced Debug Mode Clock Tests describes the measurement clock tests including clock period jitter, cycle to cycle period jitter, cumulative error, and half period jitter.
- **Chapter 12**, “Advanced Debug Mode High-Low State Ringing Tests shows the high state and low state ringing test method of implementation.
- **Chapter 13**, “Calibrating the Infiniium Oscilloscope and Probe describes how to calibrate the oscilloscope in preparation for running the automated tests.
- **Chapter 14**, “InfiniiMax Probing describes the probe amplifier and probe head recommendations for testing.
- **Chapter 15**, “Common Error Messages describes the error dialog boxes that can appear and how to remedy the problem.

See Also

- The DDR1 Compliance Test Application's online help, which describes:
 - Starting the DDR1 compliance test application.
 - Creating or opening a test project.
 - Setting up DDR1 test environment.
 - Selecting tests.
 - Configuring selected tests.
 - Connecting the oscilloscope to the DUT.
 - Running tests.
 - Viewing test results.
 - Viewing/printing the HTML test report.
 - Understanding the HTML report.
 - Saving test projects.

Contact Keysight

For more information on DDR1 Compliance Test Application or other Keysight Technologies' products, applications and services, please contact your local Keysight office. The complete list is available at:

www.keysight.com/find/contactus

Phone or Fax

United States:

(tel) 800 829 4444

(fax) 800 829 4433

Canada:

(tel) 877 894 4414

(fax) 800 746 4866

China:

(tel) 800 810 0189

(fax) 800 820 2816

Europe:

(tel) 31 20 547 2111

Japan:

(tel) (81) 426 56 7832

(fax) (81) 426 56 7840

Korea:

(tel) (080) 769 0800

(fax) (080) 769 0900

Latin America:

(tel) (305) 269 7500

Taiwan:

(tel) 0800 047 866

(fax) 0800 286 331

Other Asia Pacific Countries:

(tel) (65) 6375 8100

(fax) (65) 6755 0042

E-mail: tm_ap@keysight.com

Contents

Quick Reference	3
DDR1 Compliance Test Application – At A Glance	5
Required Equipment and Software	6
In This Book	7
See Also	8
Contact Keysight	9
Phone or Fax	9

1 Installing the DDR1 Compliance Test Application

Installing the Software	22
Installing the License Key	23

2 Preparing to Take Measurements

Calibrating the Oscilloscope	26
Starting the DDR1 Compliance Test Application	27
Online Help Topics	29

3 Single-Ended Signals AC Input Parameters Tests

Probing for Single-Ended Signals AC Input Parameters Tests	32
Test Procedure	32
SlewR Test Method of Implementation	35
Signals of Interest	36
Test Definition Notes from the Specification	36
PASS Condition	36
Measurement Algorithm	36
Test References	37
SlewF Test Method of Implementation	38
Signals of Interest	39
Test Definition Notes from the Specification	39
PASS Condition	39
Measurement Algorithm	39
Test References	40

VIH(AC) Test Method of Implementation	41
Signals of Interest	41
Test Definition Notes from the Specification	42
PASS Condition	42
Measurement Algorithm	42
Test References	43
VIH(DC) Test Method of Implementation	44
Signals of Interest	44
Test Definition Notes from the Specification	45
PASS Condition	45
Measurement Algorithm	45
Test References	46
VIL(AC) Test Method of Implementation	47
Signals of Interest	47
Test Definition Notes from the Specification	48
PASS Condition	48
Measurement Algorithm	48
Test References	49
VIL(DC) Test Method of Implementation	50
Signals of Interest	50
Test Definition Notes from the Specification	51
PASS Condition	51
Measurement Algorithm	51
Test References	51
4 Single-Ended Signals AC Output Parameters Tests	
Probing for Single-Ended Signals AC Output Parameters Tests	54
Test Procedure	54
VOH(AC) Test Method of Implementation	57
Signals of Interest	57
Test Definition Notes from the Specification	58
PASS Condition	58
Measurement Algorithm	58
Test References	58
VOL(AC) Test Method of Implementation	59
Signals of Interest	59
Test Definition Notes from the Specification	60
PASS Condition	60
Measurement Algorithm	60
Test References	60

5 Single-Ended Signals Overshoot/Undershoot Tests

Probing for Overshoot/Undershoot Tests	62
Test Procedure	62
AC Overshoot Test Method of Implementation	65
Signals of Interest	65
Test Definition Notes from the Specification	66
PASS Condition	66
Measurement Algorithm	66
Test References	67
AC Undershoot Test Method of Implementation	68
Signals of Interest	68
Test Definition Notes from the Specification	69
PASS Condition	69
Measurement Algorithm	69
Test References	70

6 Differential Signals AC Input Parameters Tests

Probing for Differential Signals AC Input Parameters Tests	72
Test Procedure	72
VID(AC), AC Differential Input Voltage - Test Method of Implementation	75
Signals of Interest	76
Test Definition Notes from the Specification	77
PASS Condition	77
Measurement Algorithm	77
Test References	77
VIX(AC), AC Differential Input Cross Point Voltage -Test Method of Implementation	78
Signals of Interest	79
PASS Condition	79
Measurement Algorithm	79
Test References	79

7 Data Strobe Timing (DST) Tests

Probing for Data Strobe Timing Tests	82
Test Procedure	82
tHZ(DQ), DQ High Impedance Time From CK/CK# - Test Method of Implementation	85
Signals of Interest	85
Test Definition Notes from the Specification	85
PASS Condition	86
Measurement Algorithm	86
Test References	86

tHZ(DQS), DQS High Impedance Time From CK/CK# - Test Method of Implementation	87
Signals of Interest	87
Test Definition Notes from the Specification	87
PASS Condition	88
Measurement Algorithm	88
Test References	88
tLZ(DQS), DQS Low-Impedance Time from CK/CK# - Test Method of Implementation	89
Signals of Interest	89
Test Definition Notes from the Specification	89
PASS Condition	90
Measurement Algorithm	90
Test References	90
tLZ(DQ), DQ Low-Impedance Time from CK/CK# - Test Method of Implementation	91
Signals of Interest	91
Test Definition Notes from the Specification	92
PASS Condition	92
Measurement Algorithm	92
Test References	93
tDQSQ, DQS-DQ Skew for DQS and Associated DQ Signals - Test Method of Implementation	94
Signals of Interest	94
Test Definition Notes from the Specification	94
PASS Condition	94
Measurement Algorithm	94
Test References	95
tQH, DQ/DQS Output Hold Time From DQS - Test Method of Implementation	96
Signals of Interest	96
Test Definition Notes from the Specification	96
PASS Condition	96
Measurement Algorithm	96
Test References	97
tDQSS, DQS Latching Transition to Associated Clock Edge - Test Method of Implementation	98
Signals of Interest	98
Test Definition Notes from the Specification	98
PASS Condition	98
Measurement Algorithm	98
Test References	99

tDQSH, DQS Input High Pulse Width - Test Method of Implementation	100
Signals of Interest	100
Test Definition Notes from the Specification	100
PASS Condition	100
Measurement Algorithm	100
Test References	101
tDQSL, DQS Input Low Pulse Width - Test Method of Implementation	102
Signals of Interest	102
Test Definition Notes from the Specification	102
PASS Condition	102
Measurement Algorithm	102
Test References	103
tDSS, DQS Falling Edge to CK Setup Time - Test Method of Implementation	104
Signals of Interest	104
Test Definition Notes from the Specification	104
PASS Condition	104
Measurement Algorithm	104
Test References	105
tDSH, DQS Falling Edge Hold Time from CK - Test Method of Implementation	106
Signals of Interest	106
Test Definition Notes from the Specification	106
PASS Condition	106
Measurement Algorithm	106
Test References	107
tWPST, Write Postamble - Test Method of Implementation	108
Signals of Interest	108
Test Definition Notes from the Specification	108
PASS Condition	108
Measurement Algorithm	108
Test References	109
tWPRE, Write Preamble - Test Method of Implementation	110
Signals of Interest	110
Test Definition Notes from the Specification	110
PASS Condition	111
Measurement Algorithm	111
Test References	111

tRPRE, Read Preamble - Test Method of Implementation	112
Signals of Interest	112
Test Definition Notes from the Specification	112
PASS Condition	112
Measurement Algorithm	113
Test References	113
tRPST, Read Postamble - Test Method of Implementation	114
Signals of Interest	114
Chip Select Signal (CS as additional signal, which requires an additional channel)	114
Test Definition Notes from the Specification	114
PASS Condition	114
Measurement Algorithm	114
Test References	115
8 Clock Timing (CT) Tests	
Probing for Clock Timing Tests	118
Test Procedure	118
tAC, DQ Output Access Time from CK/CK# - Test Method of Implementation	121
Signals of Interest	121
Test Definition Notes from the Specification	121
Pass Condition	122
Measurement Algorithm	122
Test References	123
tDQSCK, DQS Output Access Time from CK/CK# - Test Method of Implementation	124
Signals of Interest	125
Test Definition Notes from the Specification	126
PASS Condition	126
Measurement Algorithm	126
Test References	127
Average Clock Period - tCK(avg) - Test Method of Implementation	128
Signals of Interest	128
Test Definition Notes from the Specification	128
PASS Condition	128
Measurement Algorithm	129
Test References	129
Average High Pulse Width - tCH(avg) - Test Method of Implementation	130
Signals of Interest	130
Test Definition Notes from the Specification.	130
Pass Condition	130
Measurement Algorithm	130
Test References	130

Average Low Pulse Width - tCL(avg) - Test Method of Implementation 131

Signals of Interest	131
Test Definition Notes from the Specification.	131
Pass Condition	131
Measurement Algorithm	131
Test References	131

9 Data Mask Timing (DMT) Tests**Probing for Data Mask Timing Tests 134**

Test Procedure	134
----------------	-----

tDS(base), DQ and DM Input Setup Time - Test Method of Implementation 137

Signals of Interest	137
Test Definition Notes from the Specification	137
PASS Condition	137
Measurement Algorithm	138
Test References	138

tDH(base), DQ and DM Input Hold Time - Test Method of Implementation 139

Signals of Interest	139
Test Definition Notes from the Specification	139
PASS Condition	140
Measurement Algorithm	140
Test References	140

10 Command and Address Timing (CAT) Tests**Probing for Command and Address Timing Tests 142**

Test Procedure	143
----------------	-----

tIS(base) - Address and Control Input Setup Time - Test Method of Implementation 145

Signals of Interest	145
Test Definition Notes from the Specification	145
PASS Condition	145
Measurement Algorithm	146
Test References	146

tIH(base) - Address and Control Input Hold Time - Test Method of Implementation 147

Signals of Interest	147
Test Definition Notes from the Specification	147
PASS Condition	147
Measurement Algorithm	148
Test References	148

11 Advanced Debug Mode Clock Tests

Probing for Clock Tests	150
Test Procedure	150
Clock Period Jitter - tJIT(per) - Test Method of Implementation	154
Signals of Interest	154
Measurement Algorithm	154
Cycle to Cycle Period Jitter - tJIT(cc) - Test Method of Implementation	155
Signals of Interest	155
Measurement Algorithm	155
Cumulative Error - tERR(n per) - Test Method of Implementation	156
Signals of Interest	156
Measurement Algorithm	156
Half Period Jitter - tJIT(duty) - Test Method of Implementation	157
Signals of Interest	157
Measurement Algorithm	157

12 Advanced Debug Mode High-Low State Ringing Tests

Probing for Advanced Debug Mode High-Low State Ringing Tests	160
Test Procedure	160
High State Ringing Tests Method of Implementation	164
Signals of Interest	164
Measurement Algorithm	165
Low State Ringing Tests Method of Implementation	166
Signals of Interest	166
Measurement Algorithm	167

13 Calibrating the Infiniium Oscilloscope and Probe

Required Equipment for Oscilloscope Calibration	170
Internal Calibration	171
Required Equipment for Probe Calibration	174
Probe Calibration	175
Connecting the Probe for Calibration	175
Verifying the Connection	177
Running the Probe Calibration and Deskew	179
Verifying the Probe Calibration	182

14 InfiniiMax Probing

15 Common Error Messages

Required Triggering Condition Not Met 188

Software License Error 190

Frequency Out of Range Error 191

Missing Signal Error 192

Invalid Pre/PostAmble Signal Error 193

Index

1 Installing the DDR1 Compliance Test Application

Installing the Software / 22

Installing the License Key / 23

If you purchased the U7233A/U7233B DDR1 Compliance Test Application separately, you need to install the software and license key.

Installing the Software

- 1 Make sure you have version 05.30 or higher of the Infiniium oscilloscope software or baseline software revision 1.0 by choosing Help>About Infiniium... from the main menu.
- 2 To obtain the DDR1 Compliance Test Application, go to Keysight website:
<http://www.keysight.com/find/U7233A/U7233B>.
- 3 The link for DDR1 Compliance Test Application will appear. Double-click on it and follow the instructions to download and install the application software.

Installing the License Key

- 1 Request a license code from Keysight by following the instructions on the Entitlement Certificate. You will need the oscilloscope's "Option ID Number", which you can find in the Help>About Infiniium... dialog box.
- 2 After you receive your license code from Keysight, choose Utilities>Install Option License....
- 3 In the Install Option License dialog, enter your license code and click Install License.
- 4 Click OK in the dialog that tells you to restart the Infiniium oscilloscope application software to complete the license installation.
- 5 Click Close to close the Install Option License dialog.
- 6 Choose File>Exit.
- 7 Restart the Infiniium oscilloscope application software to complete the license installation.

1 Installing the DDR1 Compliance Test Application

2 Preparing to Take Measurements

Calibrating the Oscilloscope / 26

Starting the DDR1 Compliance Test Application / 27

Before running the DDR1 automated tests, you should calibrate the oscilloscope and probe. No test fixture is required for application. After the oscilloscope and probe have been calibrated, you are ready to start the DDR1 Compliance Test Application and perform the measurements.

Calibrating the Oscilloscope

If you haven't already calibrated the oscilloscope and probe, see [Chapter 13](#), "Calibrating the Infiniium Oscilloscope and Probe."

NOTE

If the ambient temperature changes more than 5 degrees Celsius from the calibration temperature, internal calibration should be performed again. The delta between the calibration temperature and the present operating temperature is shown in the Utilities>Calibration menu.

NOTE

If you switch cables between channels or other oscilloscopes, it is necessary to perform cable and probe calibration again. Keysight recommends that, once calibration is performed, you label the cables with the channel on which they were calibrated.

Starting the DDR1 Compliance Test Application

- 1 Ensure that the RAM reliability test software is running in the computer system where the Device Under Test (DUT) is attached. This software performs tests to all unused RAM in the system by producing a repetitive burst of read-write data signals to the DDR memory.
- 2 To start the DDR1 Compliance Test Application: From the Infiniium oscilloscope's main menu, choose Analyze>Automated Test Apps>DDR1 Test.

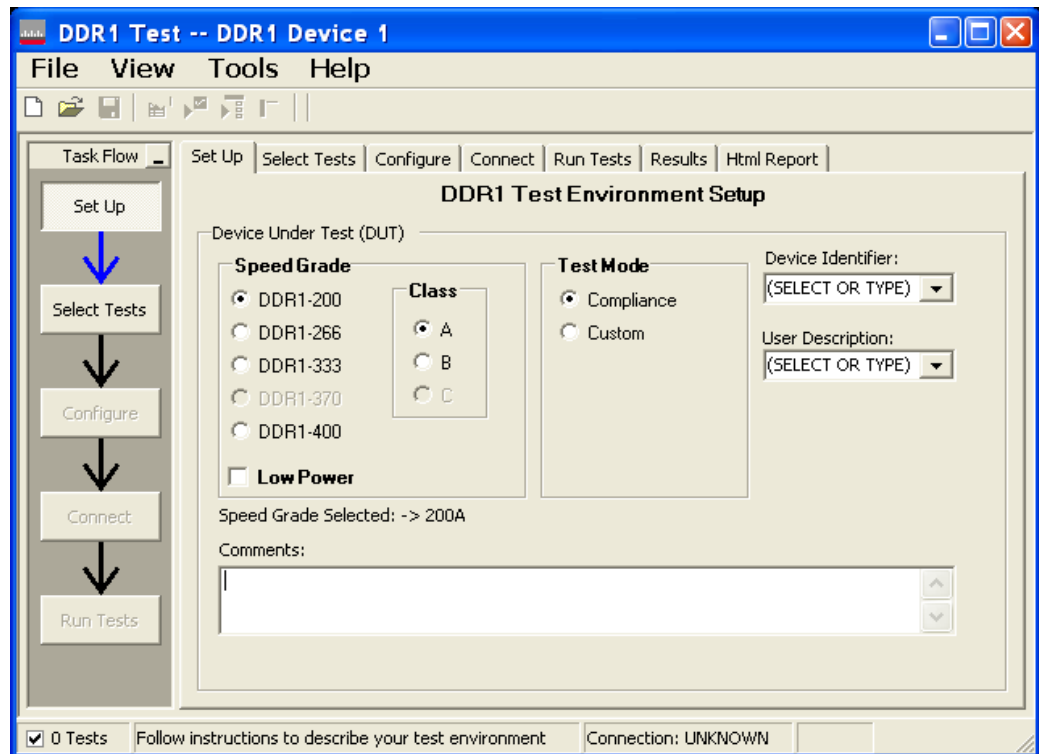
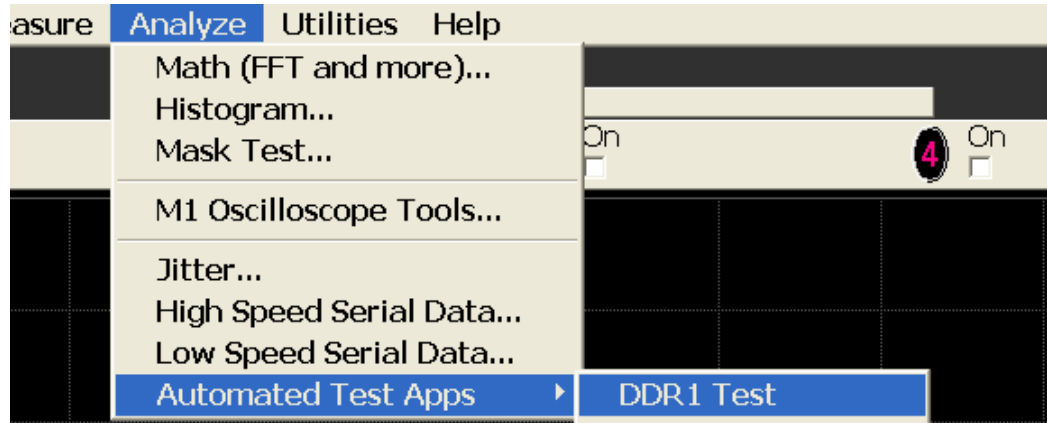

Figure 1 The DDR1 Compliance Test Application

NOTE

If DDR1 Test does not appear in the Automated Test Apps menu, the DDR1 Compliance Test Application has not been installed (see [Chapter 1](#), “Installing the DDR1 Compliance Test Application”).

[Figure 1](#) shows the DDR1 Compliance Test Application main window. The task flow pane, and the tabs in the main pane, show the steps you take in running the automated tests:

Tab	Description
Set Up	Lets you identify and setup the test environment, including information about the device under test.
Select Tests	Lets you select the tests you want to run. The tests are organized hierarchically so you can select all tests in a group. After tests are run, status indicators show which tests have passed, failed, or not been run, and there are indicators for the test groups.
Configure	Lets you configure test parameters (like memory depth). This information appears in the HTML report.
Connect	Shows you how to connect the oscilloscope to the device under test for the tests to be run.
Run Tests	Starts the automated tests. If the connections to the device under test need to be changed while multiple tests are running, the tests pause, show you how to change the connection, and wait for you to confirm that the connections have been changed before continuing.
Results	Contains more detailed information about the tests that have been run. You can change the thresholds at which marginal or critical warnings appear.
HTML Report	Shows a compliance test report that can be printed.

NOTE

When you close the DDR1 application, each channel's probe is configured as single-ended or differential depending on the last DDR1 test that was run.

Online Help Topics

For information on using the DDR1 Compliance Test Application, see its online help (which you can access by choosing Help>Contents... from the application's main menu).

The DDR1 Compliance Test Application's online help describes:

- Starting the DDR1 Automated Test Application.
 - To view or minimize the task flow pane.
 - To view or hide the toolbar.
- Creating or opening a test project.
- Setting up DDR1 test environment.
- Selecting tests.
- Configuring selected tests.
- Connecting the oscilloscope to the Device Under Test (DUT).
- Running tests.
- Viewing test results.
 - To show reference images and flash mask hits.
 - To change margin thresholds.
- Viewing/printing the HTML test report.
- Understanding the HTML report.
- Saving test projects.

3 Single-Ended Signals AC Input Parameters Tests

Probing for Single-Ended Signals AC Input Parameters Tests /	32
SlewR Test Method of Implementation /	35
SlewF Test Method of Implementation /	38
VIH(AC) Test Method of Implementation /	41
VIH(DC) Test Method of Implementation /	44
VIL(AC) Test Method of Implementation /	47
VIL(DC) Test Method of Implementation /	50

This section provides the Methods of Implementation (MOIs) for Single-Ended Signals AC Input tests using an Keysight 54850A, 8000, 80000 or 90000A series Infiniium oscilloscope, recommended InfiniiMax 116xA or 113xA probe amplifiers, E2677A differential solder-in probe head and the DDR1 Compliance Test Application.

Probing for Single-Ended Signals AC Input Parameters Tests

When performing the Single-Ended Signals AC Input Parameters tests, the DDR1 Compliance Test Application will prompt you to make the proper connections. The connection for the Single-Ended Signals AC Input Parameters tests may look similar to the following diagram. Refer to the Connection tab in DDR1 Compliance Test Application for the exact number of probe connections.

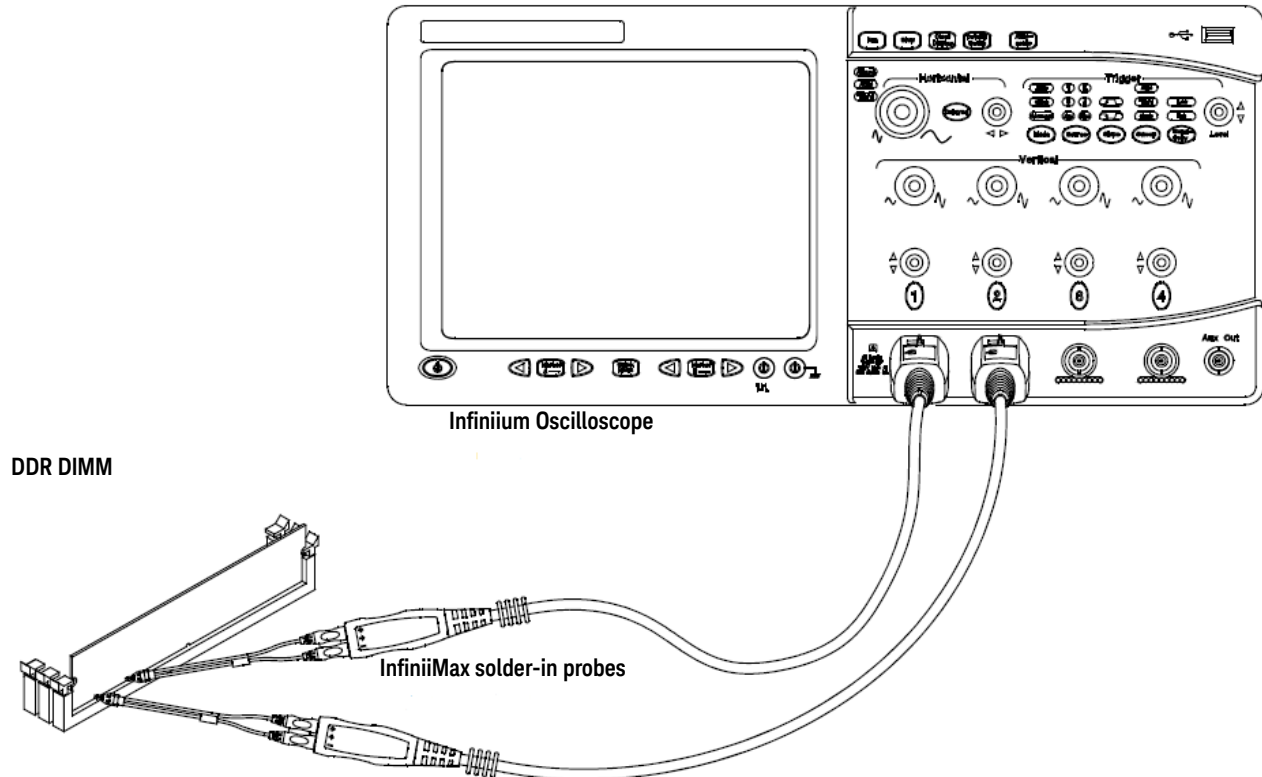

Figure 2 Probing for Single-Ended Signals AC Input Parameters Tests with Two Probes

You can use any of the oscilloscope channels as Pin Under Test (PUT) source channel. You can identify the channels used for each signal in the Configuration tab of the DDR1 Compliance Test Application. (The channels shown in [Figure 2](#) are just examples).

For more information on the probe amplifiers and differential probe heads, see [Chapter 14](#), “InfiniiMax Probing,” starting on page 185.

Test Procedure

- 1 Start the automated test application as described in [“Starting the DDR1 Compliance Test Application”](#) on page 27.
- 2 Ensure that the RAM reliability test software is running on the computer system where the DDR Device Under Test (DUT) is attached. This software will perform a test on all unused RAM on the system by producing a repetitive burst of read-write data signals to the DDR memory.
- 3 Connect the differential solder-in probe head to the PUTs on the DDR DIMM.
- 4 Connect the oscilloscope probes to any channels of the oscilloscope.
- 5 In the DDR1 Test Application, click the Set Up tab.

- 6 Select the Speed Grade options. For the Single-Ended Signals AC Input Parameters Tests, you can select any speed grade within the selection: DDR1-200, DDR1-266, DDR1-333, DDR1-400.
- 7 Type in or select the Device Identifier as well as User Description from the drop-down list. Enter your comments in the Comments text box.
- 8 Click the Select Tests tab and check the tests you want to run. Check the parent node or group to check all the available tests within the group.

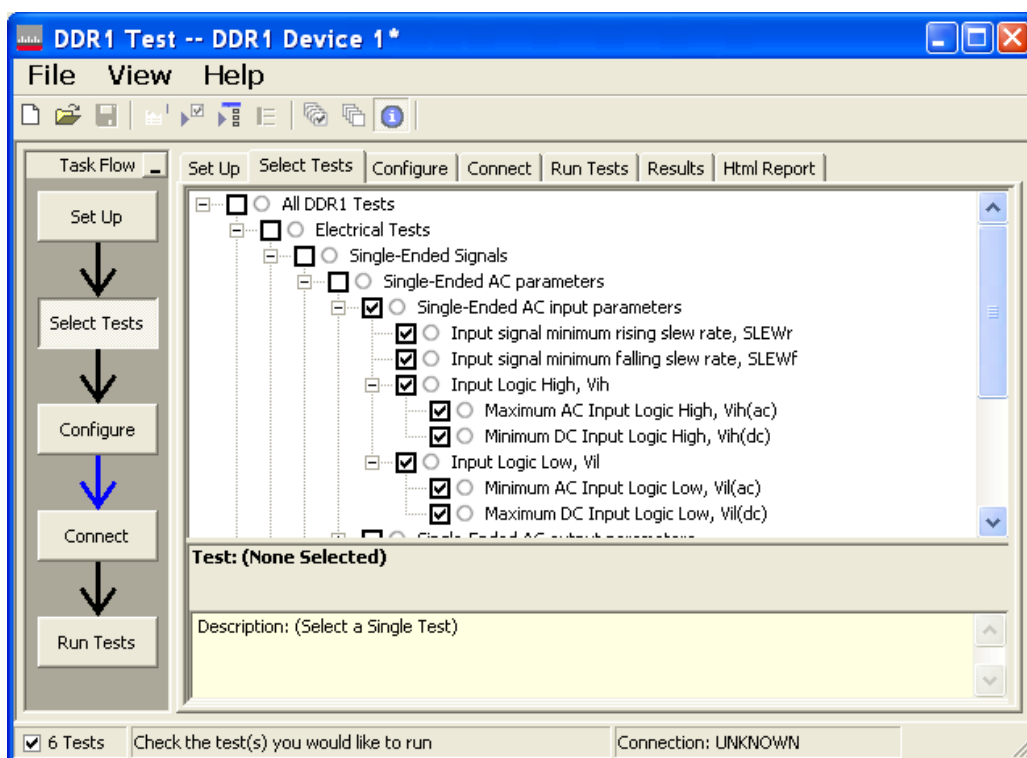

Figure 3 Selecting Single-Ended Signals AC Input Parameters Tests

- 9 Follow the DDR1 Test Application's task flow to set up the configuration options (see Table 2), run the tests and view the tests results.

Table 2 Test Configuration Options

Configuration Option	Description
Stop on error	Enabling this error message will allow error message to prompt whenever criteria is not met. Disabling this option will allow the system to bypass all the error messages that could occur and continue to the next test. This option is suitable for long hours multiple trial.
Signal Threshold setting by percentage	This option allow user to define the Upper and Lower threshold of the signal by percentage.
VDD	Input supply voltage value.
VDDQ	Input supply voltage for data output.
Vref	Input reference voltage value.
Vih(DC)	Input voltage high value (direct current).
Vih(AC)	Input voltage high value (alternating current).
Vil(DC)	Input voltage low value (direct current).
Vil(AC)	Input voltage low value (alternating current).
InfiniiScan Limits	
Read Cycle	
IScan_UL_READ	Identifies the upper limit for Setup Time measurement used in the InfiniiScan Measurement Mode (READ cycle)
IScan_LL_READ	Identifies the lower limit for Setup Time measurement used in the InfiniiScan Measurement Mode (READ cycle)
Write Cycle	
IScan_UL_WRITE	Identifies the upper limit for Setup Time measurement used in the InfiniiScan Measurement Mode (WRITE cycle)
IScan_LL_WRITE	Identifies the upper limit for Setup Time measurement used in the InfiniiScan Measurement Mode (WRITE cycle)
Single-Ended Signals	
Single-Ended AC Parameters	
Pin Under Test, PUT	Identifies the Pin Under Test for Single-Ended AC parameters.
PUT Source	Identifies the source of the PUT to be analyzed for Single-Ended AC tests.
Supporting Pin	Identifies the required supporting pin for Single-Ended AC parameters.
Supporting Pin Source	Identifies the source of the supporting pin for Single-Ended AC Tests.

Slew_R Test Method of Implementation

Slew_R - Input Signal Minimum Slew Rate (Rising). The purpose of this test is to verify that the rising slew rate value of the test signal is greater than or equal to the conformance limit of the input SLEW value specified in the JEDEC Standard JESD79E.

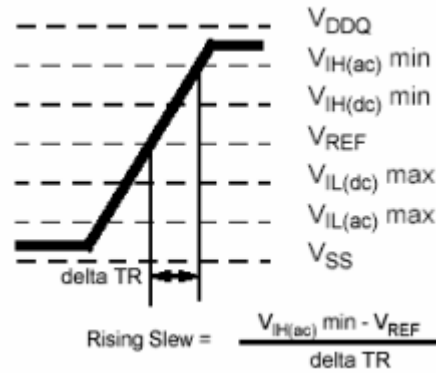

Figure 4 Slew_R

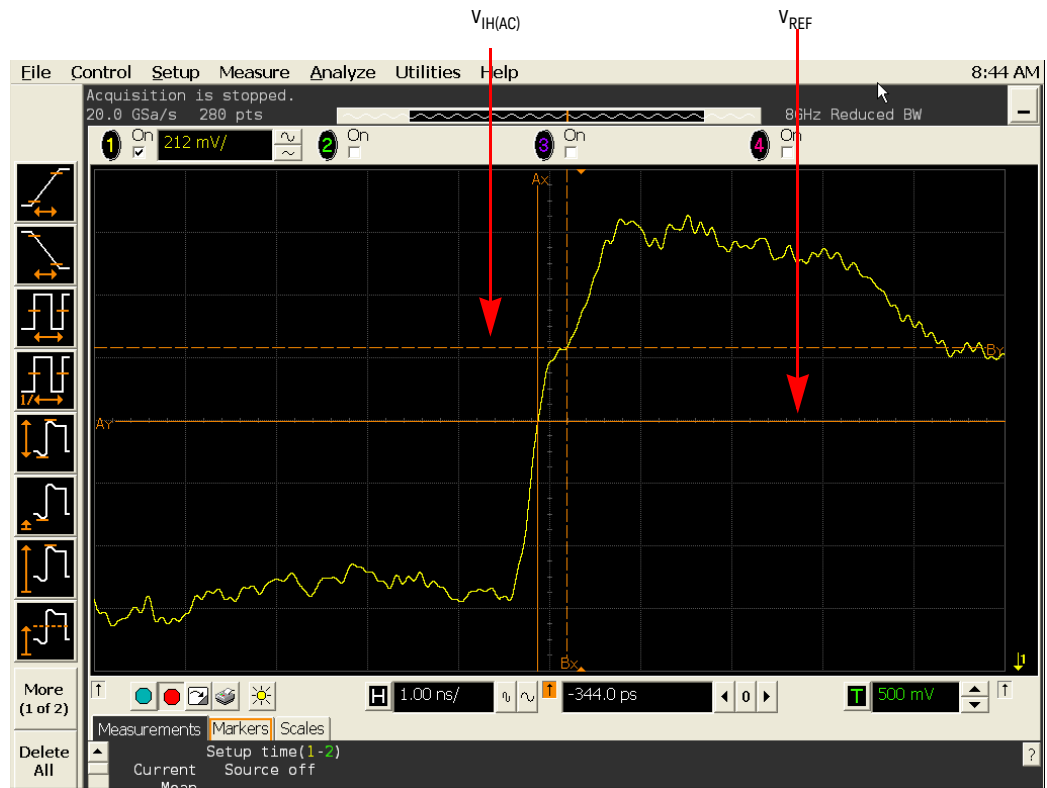

Figure 5 Slew_R in Infiniium oscilloscope.

Signals of Interest

Based on the test definition (Write cycle only):

- Data Signal
- Data Strobe Signal OR
- Address Signal OR
- Control Signal OR
- Data Mask Control Signals

Signals required to perform the test on the oscilloscope:

- Data Signal (DQ as Pin Under Test Signal)*
- Data Strobe Signal (DQS as Supporting Signal)
- Clock Signal - CK is required to perform pre-test to verify the DUT speed against user's speed grade selection

* Pin Under Test signal can be either one of the signals under the test definition.

Test Definition Notes from the Specification

Table 3 Input Slew Rate for DQ, DQS and DM

AC Characteristics - Parameter	Symbol	DDR 400		DDR 333		DDR 266		DDR 200		Units	Notes
		Min	Max	Min	Max	Min	Max	Min	Max		
DQ/DM/DQS input slew rate measured between VIH(DC), VIL(DC) and VIL(DC), VIH(DC)	DCSlew	0.5	4.0	0.5	4.0	0.5	4.0	0.5	4.0	V/ns	a, m

NOTE a and m: Please refer to the *JEDEC Standard JESD79E*.

PASS Condition

$$\geq \text{SLEW}_R$$

The calculated Rising Slew value for the test signal should be greater than or equal to the SLEW value.

Measurement Algorithm

- 1 Calculate the initial time scale value based on the selected DDR1 speed grade.
- 2 Pre-condition the scope settings. Verify the actual DUT speed against the user speed selection at the Setup page.
- 3 Calculate the number of sampling points according to the time scale value.
- 4 Obtain sample or acquire signal data and perform signal conditioning to maximize the screen resolution (vertical scale adjustment).
- 5 Perform signal checking on all the signals in-use in the measurement to ensure that it can be triggered during the test. This includes Vp-p, Vmin, Vmax and Vmid of each signal.
- 6 Perform signal skew checking on the DQ-DQS to ensure that it can be triggered during the Read/Write separation later.
- 7 Setup the required scope settings and histogram function settings.
- 8 Verify that V_{REF} and V_{IH(AC)} points can be found on the oscilloscope screen.

- 9 Calculate the delta TR.
- 10 Calculate Rising Slew.

$$\mathbf{RisingSlew} = \frac{V_{IH(ac)min} - V_{REF}}{\Delta TR}$$

- 11 Compare test results against the compliance test limit.

Test References

See Table 13 - Input Slew Rate for DQ, DQS, and DM, in the *JEDEC Standard JESD79E*.

Slew_F Test Method of Implementation

Slew_F - Input Signal Minimum Slew Rate (Falling). The purpose of this test is to verify that the falling slew rate value of the test signal is greater than or equal to the conformance limit of the input SLEW value specified in the JEDEC Standard JESD79E.

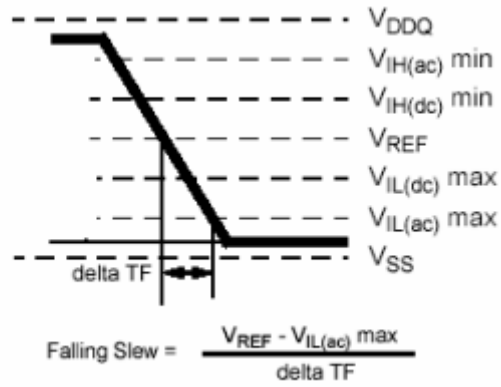

Figure 6 Slew_F



Figure 7 Slew_F in Infiniium oscilloscope.

Signals of Interest

Based on the test definition (Write cycle only):

- Data Signal
- Data Strobe Signal OR
- Address Signal OR
- Control Signal OR
- Data Mask Control Signals

Signals required to perform the test on the oscilloscope:

- Data Signal (DQ as Pin Under Test Signal)*
- Data Strobe Signal (DQS as Supporting Signal)
- Clock Signal - CK is required to perform pre-test to verify the DUT speed against user's speed grade selection

* Pin Under Test signal can be either one of the signals under the test definition.

Test Definition Notes from the Specification

Table 4 Input Slew Rate for DQ, DQS, and DM

AC Characteristics - Parameter	Symbol	DDR 400		DDR 333		DDR 266		DDR 200		Units	Notes
		Min	Max	Min	Max	Min	Max	Min	Max		
DQ/DM/DQS input slew rate measured between VIH(DC), VIL(DC) and VIL(DC), VIH(DC)	DCSlew	0.5	4.0	0.5	4.0	0.5	4.0	0.5	4.0	V/ns	a, m

NOTE a and m: Please refer to the *JEDEC Standard JESD79E*.

PASS Condition

$$\geq \text{SLEW}_F$$

The calculated Rising Slew value for the test signal should be greater than or equal to the SLEW value.

Measurement Algorithm

- 1 Calculate the initial time scale value based on the selected DDR1 speed grade options.
- 2 Pre-condition the scope settings. Verify the actual DUT speed against the user speed selection at the Setup page.
- 3 Calculate the number of sampling points according to the time scale value.
- 4 Obtain sample or acquire signal data and perform signal conditioning to maximize the screen resolution (vertical scale adjustment).
- 5 Perform signal checking on all the signals in-use in the measurement to ensure that it can be triggered during the test. This includes Vp-p, Vmin, Vmax and Vmid of each signal.
- 6 Perform signal skew checking on DQ-DQS to make sure it can be triggered during Read/Write separation later.
- 7 Setup the required scope settings and histogram function settings.
- 8 Verify that V_{REF} and V_{IL(AC)} points can be found on the oscilloscope screen.
- 9 Calculate the delta TR.
- 10 Calculate the Falling Slew.

$$\text{FallingSlew} = \frac{V_{\text{REF}} - V_{\text{IL(ac)max}}}{\Delta\text{TF}}$$

11 Compare test results against the compliance test limit.

Test References

See Table 13 - Input Slew Rate for DQ, DQS, and DM, in the *JEDEC Standard JESD79E*.

V_{IH(AC)} Test Method of Implementation

V_{IH} Input Logic High Test can be divided into two sub tests - V_{IH(AC)} test and V_{IH(DC)} test.

V_{IH(AC)} - Maximum AC Input Logic High. The purpose of this test is to verify that the maximum high level voltage value of the test signal within a valid sampling window is greater than the conformance lower limit of the V_{IH(AC)} value specified in the *JEDEC Standard JESD79E*. For low power devices, the measured value must fall in between the conformance limits.

The default value of V_{REF} and V_{DDQ} which directly affects the conformance lower limit is as shown in Table 5. However, users have the flexibility to change this value.

Table 5 The default value of V_{REF} and V_{DDQ}

Speed	DDR 200, 266, 333	DDR 400	Low Power
V _{DDQ}	2.50 V	2.60 V	1.80 V
V _{REF}	1.25 V	1.30 V	0.90 V

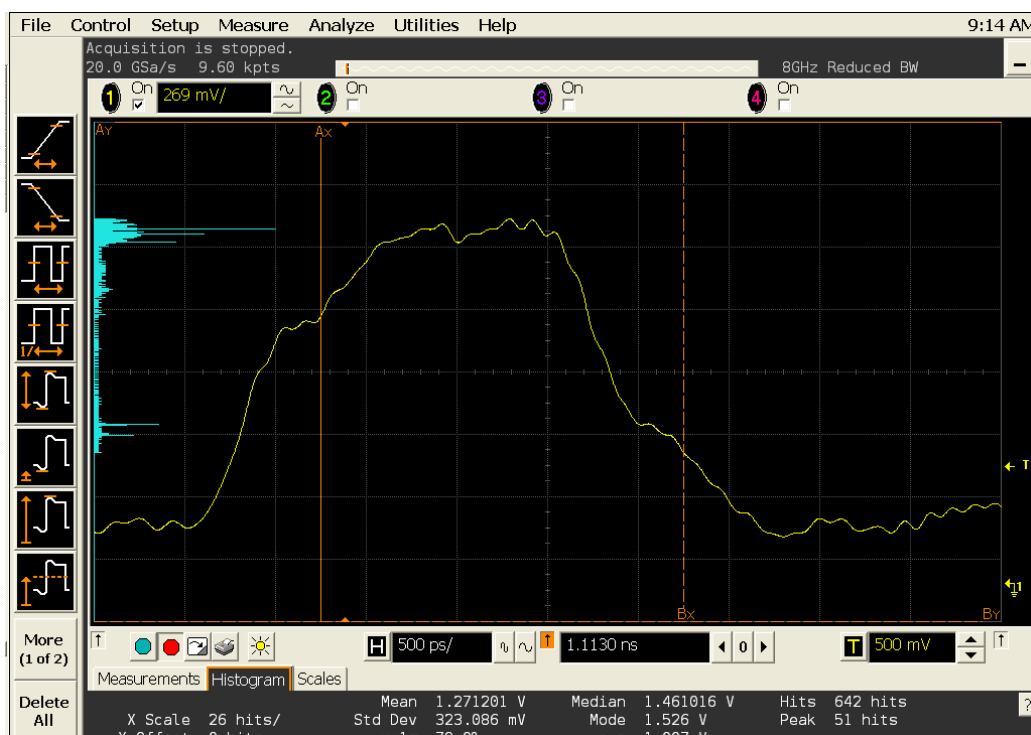

Figure 8 V_{IH(AC)} Test - Maximum AC Input Logic High in Infiniium oscilloscope.

Signals of Interest

Based on the test definition (Write cycle only):

- Data Signal
- Data Strobe Signal OR

- Control Signal OR
- Data Mask Control Signals

Signals required to perform the test on the oscilloscope:

- Data Signal (DQ as Pin Under Test Signal)*
- Data Strobe Signal (DQS as Supporting Signal)
- Clock Signal - CK is required to perform pre-test to verify the DUT speed against user's speed grade selection

* Pin Under Test signal can be either one of the signals under the test definition.

Test Definition Notes from the Specification

Table 6 AC Operating Conditions

Parameter/Condition	Symbol	Min	Max	Units
Input High (Logic 1) Voltage, DQ, DQS and DM signals	$V_{IH(AC)}$	$V_{REF} + 0.31$	-	V

Table 7 Low Power DDR SDRAM Electrical Characteristics

Parameter/Condition	Symbol	Min	Max	Units
AC Input High Voltage	$V_{IHD(AC)}$	$0.8 * V_{DDQ}$	$V_{DDQ} + 0.3$	V
Input High Voltage	V_{IH}	$0.8 * V_{DDQ}$	$V_{DDQ} + 0.3$	V

PASS Condition

The maximum value for the high level voltage should be greater than or equal to the minimum $V_{IH(AC)}$ value.

For the low power device, the value must be greater than the minimum conformance limit and less than the maximum conformance limit or equal to either one conformance limit.

Measurement Algorithm

- 1 Calculate the initial time scale value based on the selected DDR1 speed grade options.
- 2 Pre-condition the scope settings. Verify the actual DUT speed against the user speed selection at the Setup page.
- 3 Calculate the number of sampling points according to the time scale value.
- 4 Obtain sample or acquire signal data and perform signal conditioning to maximize the screen resolution (vertical scale adjustment).
- 5 Perform signal checking on all the signals in-use in the measurement to ensure that it can be triggered during the test. This includes V_{p-p} , V_{min} , V_{max} and V_{mid} of each signal.
- 6 Perform signal skew checking on the DQ-DQS to ensure that it can be triggered during the Read/Write separation later.
- 7 Setup the required scope settings and histogram function settings.
- 8 Use the histogram Max value as the test result for $V_{IH(AC)}$.
- 9 When multiple trials are performed, the smallest value (worst case) among the trials will be used as the test result for $V_{IH(AC)}$.
- 10 Compare the test results against the compliance test limits.

Test References

See Table 7 - AC Operating Conditions and Table 8 - Low Power DDR SDRAM Electrical Characteristics, in the *JEDEC Standard JESD79E*.

$V_{IH(DC)}$ Test Method of Implementation

$V_{IH(DC)}$ - Minimum DC Input Logic High. The purpose of this test is to verify that the minimum high level voltage value of the test signal within a valid sampling window is within the conformance limits of the $V_{IH(DC)}$ value specified in the *JEDEC Standard JESD79E*.

The default value of V_{REF} , V_{DD} and V_{DDQ} is as shown in Table 8. However, users have the flexibility to change this value.

Table 8 The default value of V_{REF} , V_{DD} and V_{DDQ}

Speed	DDR 200, 266, 333	DDR 400	Low Power
V_{DDQ}	2.50 V	2.60 V	1.80 V
V_{DD}	2.50 V	2.60 V	1.80 V
V_{REF}	1.25 V	1.30 V	0.90 V

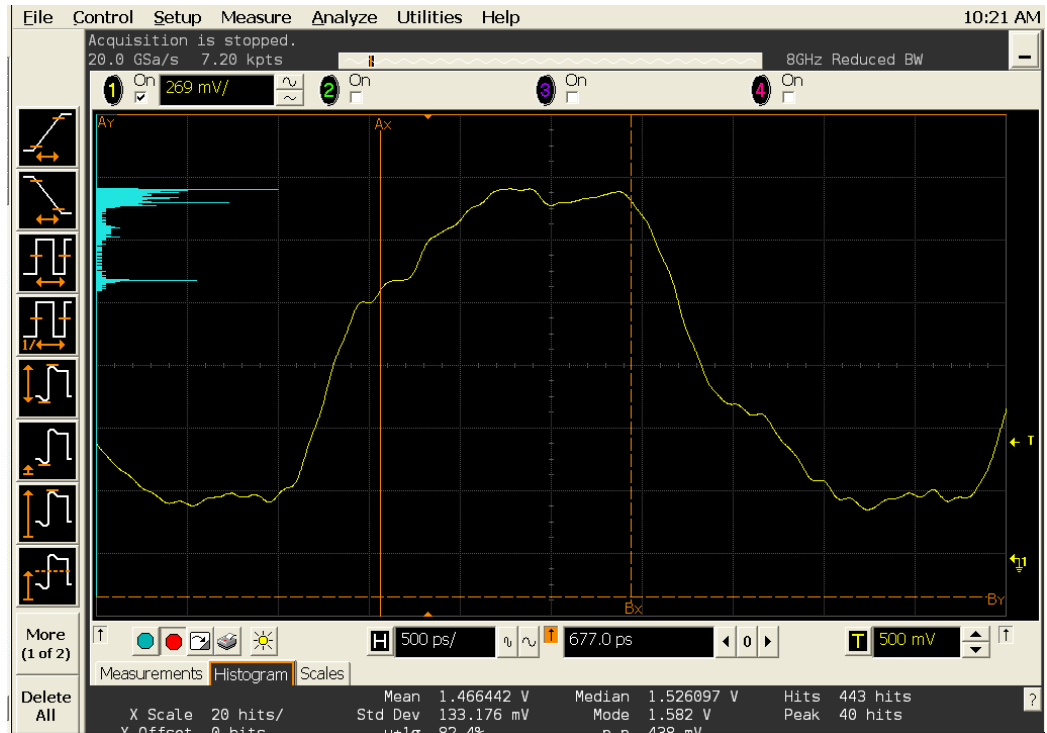

Figure 9 $V_{IH(DC)}$ Test - Minimum DC Input Logic High in Infiniium oscilloscope.

Signals of Interest

Based on the test definition (Write cycle only):

- Data Signal
- Data Strobe Signal OR
- Address Signal OR (Note: Address is not included in the Low Power)
- Control Signal OR

- Data Mask Control Signals

Signals required to perform the test on the oscilloscope:

- Data Signal (DQ as Pin Under Test Signal)*
- Data Strobe Signal (DQS as Supporting Signal)
- Clock Signal - CK is required to perform pre-test to verify the DUT speed against user's speed grade selection

* Pin Under Test signal can be either one of the signals under the test definition.

Test Definition Notes from the Specification

Table 9 Electrical Characteristics and DC Operating Conditions

Parameter/Condition	Symbol	Min	Max	Units
Input High (Logic 1) Voltage	$V_{IH(DC)}$	$V_{REF} + 0.15$	$V_{DD} + 0.3$	V

Table 10 Low Power DDR SDRAM Electrical Characteristics

Parameter/Condition	Symbol	Min	Max	Units
DC Input High Voltage	$V_{IH(DC)}$	$0.7 * V_{DDQ}$	$V_{DDQ} + 0.3$	V
Input High Voltage	V_{IH}	$0.8 * V_{DDQ}$	$V_{DDQ} + 0.3$	V

PASS Condition

The minimum value for the high level voltage should be greater than or equal to the minimum $V_{IH(DC)}$ value.

The minimum value for the high level voltage should be less than or equal to the maximum $V_{IH(DC)}$ value.

Measurement Algorithm

- 1 Calculate the initial time scale value based on the selected DDR1 speed grade options.
- 2 Pre-condition the scope settings. Verify the actual DUT speed against the user speed selection at the Setup page.
- 3 Calculate the number of sampling points according to the time scale value.
- 4 Obtain sample or acquire signal data and perform signal conditioning to maximize the screen resolution (vertical scale adjustment).
- 5 Perform signal checking on all the signals in-use in the measurement to ensure that it can be triggered during the test. This includes V_p-p , V_{min} , V_{max} and V_{mid} of each signal.
- 6 Perform signal skew checking on the DQ-DQS to ensure that it can be triggered during the Read/Write separation later.
- 7 Setup the required scope settings and histogram function settings.
- 8 Use the histogram Min value as the test result for $V_{IH(DC)}$.
- 9 When multiple trials are performed, the smallest value (worst case) among the trials will be used as the test result for $V_{IH(DC)}$.
- 10 Compare the test results against the compliance test limits.

Test References

See Table 6- Electrical Characteristics and DC Operating Conditions and Table 8 - Low Power DDR SDRAM Electrical Characteristics, in the *JEDEC Standard JESD79E*.

$V_{IL(AC)}$ Test Method of Implementation

$V_{IL(AC)}$ Input Logic Low High Test can be divided into two sub tests: $V_{IL(AC)}$ test and $V_{IL(DC)}$ test.

$V_{IL(AC)}$ - Minimum AC Input Logic Low. The purpose of this test is to verify that the minimum low level voltage value of the test signal is lower than the conformance maximum limit of the $V_{IL(AC)}$ value specified in the *JEDEC Standard JESD79E*. For low power devices, the measured value must fall in between the conformance limits.

The default value of V_{REF} and V_{DDQ} is as shown in Table 11. However, users have the flexibility to change this value.

Table 11 The default value of V_{REF} and V_{DDQ}

Speed	DDR 200, 266, 333	DDR 400	Low Power
V_{DDQ}	2.50 V	2.60 V	1.80 V
V_{REF}	1.25 V	1.30 V	0.90 V

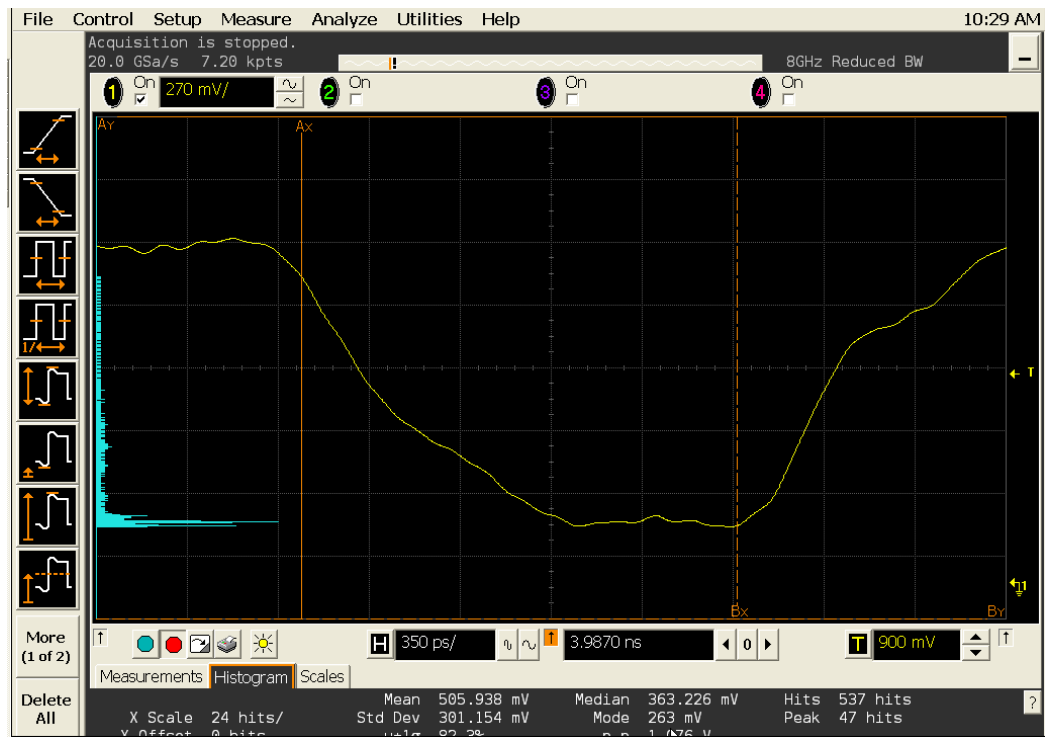

Figure 10 $V_{IL(AC)}$ Test - Minimum AC Input Logic Low in Infiniium oscilloscope.

Signals of Interest

Based on the test definition (Write cycle only):

- Data Signal
- Data Strobe Signal OR
- Control Signal OR

- Data Mask Control Signals

Signals required to perform the test on the oscilloscope:

- Data Signal (DQ as Pin Under Test Signal)*
- Data Strobe Signal (DQS as Supporting Signal)
- Clock Signal - CK is required to perform pre-test to verify the DUT speed against user's speed grade selection

* Pin Under Test signal can be either one of the signals under the test definition.

Test Definition Notes from the Specification

Table 12 AC Operating Conditions

Parameter/Condition	Symbol	Min	Max	Units
Input High (Logic 1) Voltage, DQ, DQS and DM signals	$V_{IL(AC)}$	$V_{REF} - 0.31$	-	V

Table 13 Low Power DDR SDRAM Electrical Characteristics

Parameter/Condition	Symbol	Min	Max	Units
AC Input Low Voltage	$V_{ILD(AC)}$	-0.3	$0.2 * V_{DDQ}$	V
Input Low Voltage	V_{IL}	-0.3	$0.2 * V_{DDQ}$	V

PASS Condition

The minimum value for the low level voltage should be less than or equal to the maximum $V_{IL(AC)}$ value.

For the low power device, the minimum value must be greater than the minimum conformance limits.

Measurement Algorithm

- 1 Calculate initial time scale value based on the selected DDR1 speed grade options.
- 2 Pre-condition the scope settings. Verify the actual DUT speed against the user speed selection at the Setup page.
- 3 Calculate the number of sampling points according to the time scale value.
- 4 Obtain sample or acquire signal data and perform signal conditioning to maximize the screen resolution (vertical scale adjustment).
- 5 Perform signal checking on all the signals in-use in the measurements to ensure that it can be triggered during the test. This includes V_{p-p} , V_{min} , V_{max} and V_{mid} of each signal.
- 6 Perform signal skew checking on the DQ-DQS to ensure that it can be triggered during the Read/Write separation later.
- 7 Setup the required scope settings and histogram function settings.
- 8 Use the histogram Min value as the test result for $V_{IL(AC)}$.
- 9 When multiple trials are performed, the largest value (worst case) among the trials will be used as the test result for $V_{IL(AC)}$.
- 10 Compare the test results against the compliance test limit.

Test References

See Table 7 - AC Operating Conditions and Table 8 - Low Power DDR SDRAM Electrical Characteristics, in the *JEDEC Standard JESD79E*.

$V_{IL(DC)}$ Test Method of Implementation

$V_{IL(DC)}$ - Maximum DC Input Logic Low. The purpose of this test is to verify that the maximum low level voltage value of the test signal within a valid sampling window is within the conformance limits of the $V_{IL(DC)}$ value specified in the *JEDEC Standard JESD79E*.

The default value of V_{REF} and V_{DDQ} is as shown in Table 14. However, users have the flexibility to change this value.

Table 14 The default value of V_{REF} and V_{DDQ}

Speed	DDR 200, 266, 333	DDR 400	Low Power
V_{DDQ}	2.50 V	2.60 V	1.80 V
V_{REF}	1.25 V	1.30 V	0.90 V

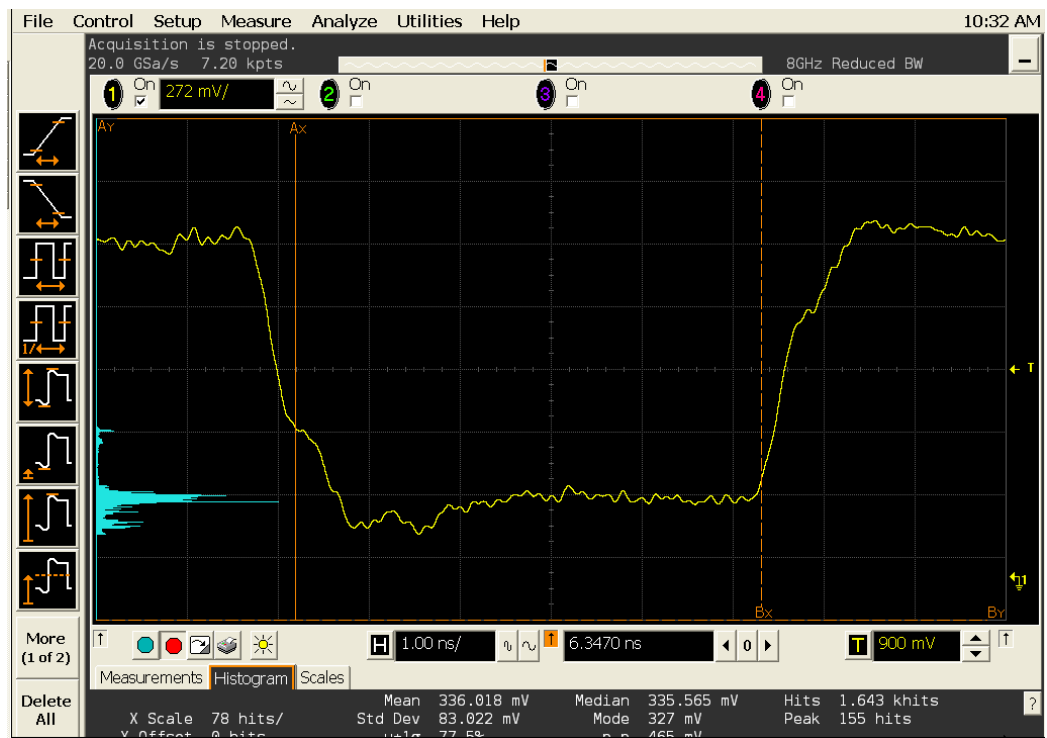

Figure 11 $V_{IL(DC)}$ Test - Maximum DC Input Logic Low in Infiniium oscilloscope.

Signals of Interest

Based on the test definition (Write cycle only):

- Data Signal
- Data Strobe Signal OR
- Address Signal OR
- Control Signal OR
- Data Mask Control Signals

Signals required to perform the test on the oscilloscope:

- Data Signal (DQ as Pin Under Test Signal)*
- Data Strobe Signal (DQS as Supporting Signal)
- Clock Signal - CK is required to perform pre-test to verify the DUT speed against user's speed grade selection

* Pin Under Test signal can be either one of the signals under the test definition.

Test Definition Notes from the Specification

Table 15 Electrical Characteristics and DC Operating Conditions

Parameter/Condition	Symbol	Min	Max	Units
Input Low (Logic 1) Voltage	$V_{IL(DC)}$	-0.3	$V_{REF} - 0.15$	V

Table 16 Low Power DDR SDRAM Electrical Characteristics

Parameter/Condition	Symbol	Min	Max	Units
DC Input Low Voltage	$V_{ILD(DC)}$	-0.3	$0.3 * V_{DDQ}$	V
Input Low Voltage	V_{IL}	-0.3	$0.3 * V_{DDQ}$	V

PASS Condition

The maximum value for the low level voltage should be less than or equal to the maximum $V_{IL(DC)}$ value.

The maximum value for the low level voltage should be greater than or equal to the minimum $V_{IL(DC)}$ value.

Measurement Algorithm

- 1 Calculate the initial time scale value based on the selected DDR1 speed grade options.
- 2 Pre-condition the scope settings. Verify the actual DUT speed against the user speed selection at the Setup page.
- 3 Calculate the number of sampling points according to the time scale value.
- 4 Obtain sample or acquire signal data and perform signal conditioning to maximize the screen resolution (vertical scale adjustment).
- 5 Perform signal checking on all the signals in-use in the measurement to ensure that it can be triggered during the test. This includes V_{p-p} , V_{min} , V_{max} and V_{mid} of each signal.
- 6 Perform signal skew checking on the DQ-DQS to ensure that it can be triggered during the Read/Write separation later.
- 7 Setup the required scope settings and histogram function settings.
- 8 Use the histogram Max value as the test result for $V_{IL(DC)}$.
- 9 When multiple trials are performed, the largest value (worst case) among all the trials will be used as the test result for $V_{IL(DC)}$.
- 10 Compare the test results against the compliance test limits.

Test References

See Table 6- Electrical Characteristics and DC Operating Conditions and Table 8 - Low Power DDR SDRAM Electrical Characteristics, in the *JEDEC Standard JESD79E*.

4 Single-Ended Signals AC Output Parameters Tests

Probing for Single-Ended Signals AC Output Parameters Tests / 54
VOH(AC) Test Method of Implementation / 57
VOL(AC) Test Method of Implementation / 59

This section provides the Methods of Implementation (MOIs) for Single-Ended Signals AC Output tests using an Keysight 54850A, 8000, 80000 or 90000A series Infiniium oscilloscope, recommended InfiniiMax 116xA or 113xA probe amplifiers, E2677A differential solder-in probe head and the DDR1 Compliance Test Application.

Probing for Single-Ended Signals AC Output Parameters Tests

When performing the Single-Ended Signals AC Output Parameters tests, the DDR1 Compliance Test Application will prompt you to make the proper connections. The connection for the Single-Ended Signals AC Output Parameters tests may look similar to the following diagram. Refer to the Connection tab in DDR1 Compliance Test Application for the exact number of probe connections.

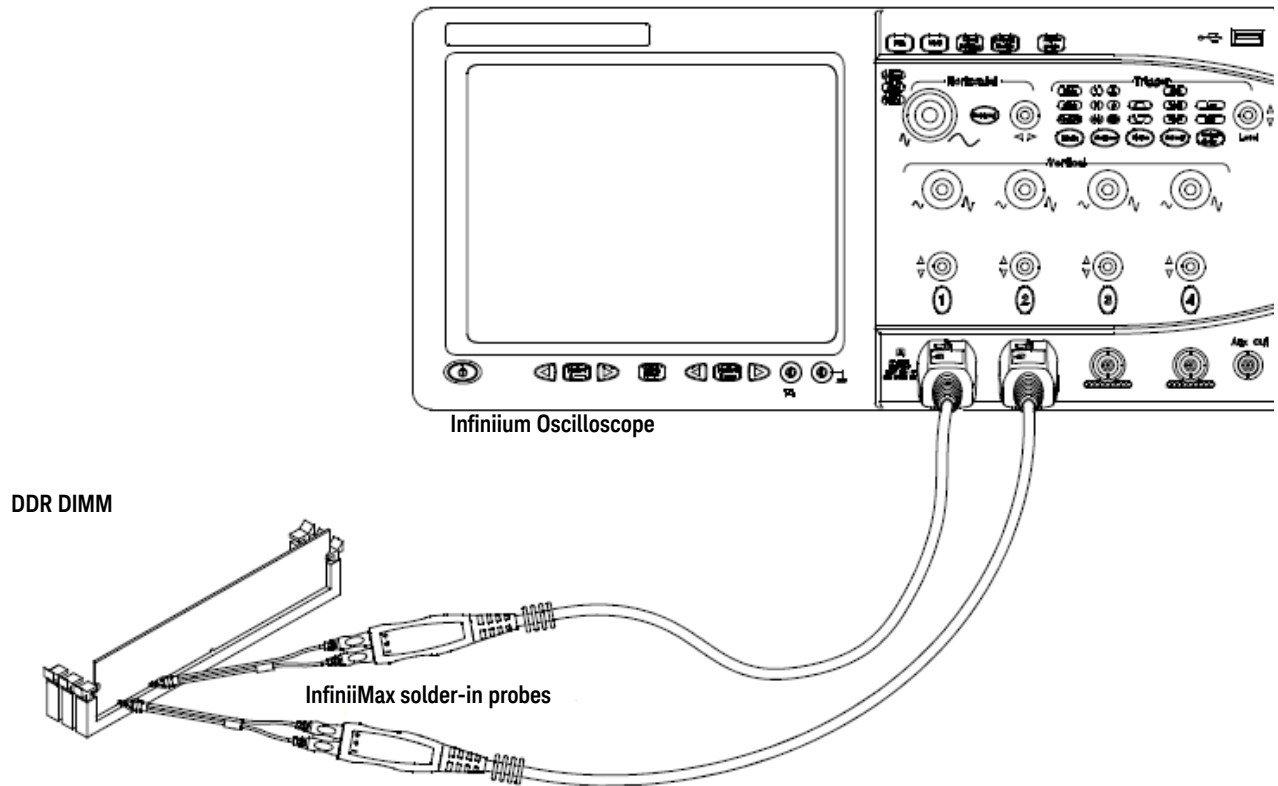

Figure 12 Probing for Single-Ended Signals AC Output Parameters Tests with Two Probes

You can use any of the oscilloscope channels as Pin Under Test (PUT) source channel. You can identify the channels used for each signal in the Configuration tab of the DDR1 Compliance Test Application. (The channels shown in [Figure 12](#) are just examples).

For more information on the probe amplifiers and differential probe heads, see [Chapter 14](#), “InfiniMax Probing,” starting on page 185.

Test Procedure

- 1 Start the automated test application as described in [“Starting the DDR1 Compliance Test Application”](#) on page 27.
- 2 Ensure that the RAM reliability test software is running on the computer system where the DDR Device Under Test (DUT) is attached. This software will perform a test on all unused RAM on the system by producing a repetitive burst of read-write data signals to the DDR memory.
- 3 Connect the differential solder-in probe head to the PUTs on the DDR DIMM.
- 4 Connect the oscilloscope probes to any channels of the oscilloscope.

- 5 In the DDR1 Test Application, click the Set Up tab.
- 6 Select the Speed Grade options. For the Single-Ended Signals AC Input Parameters Tests, you can select any speed grade within the selection: DDR1-200, DDR1-266, DDR1-333, DDR1-400.
- 7 Type in or select the Device Identifier as well as User Description from the drop-down list. Enter your comments in the Comments text box.
- 8 Click the Select Tests tab and check the tests you want to run. Check the parent node or group to check all the available tests within the group.

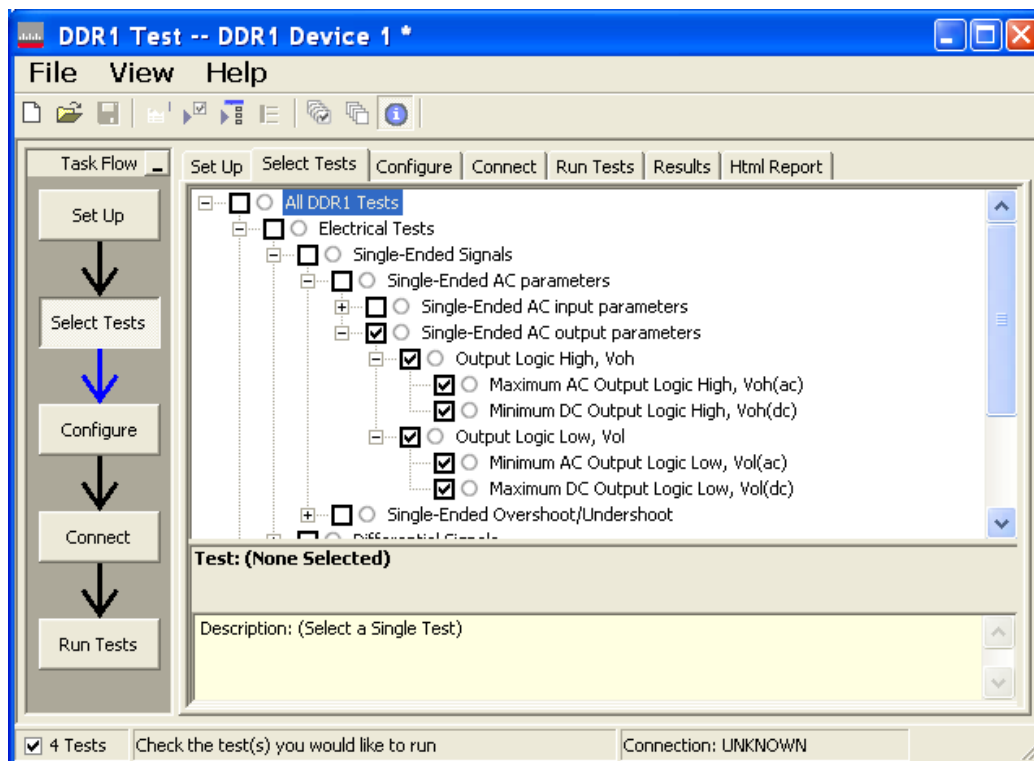

Figure 13 Selecting Single-Ended Signals AC Output Parameters Tests

- 9 Follow the DDR1 Test Application's task flow to set up the configuration options (see [Table 17](#)), run the tests and view the tests results.

Table 17 Test Configuration Options

Configuration Option	Description
Stop on error	Enabling this option will allow error messages to prompt whenever the test criteria is not met. Disabling this option will allow the system to bypass all the error messages that could occur and proceed to the next test. This option is suitable for long hours multiple trials.
Signal Threshold setting by percentage	This option allows you to define the Upper and Lower threshold of the signal by percentage.
VDD	Input supply voltage value.
VDDQ	Input supply voltage for data output.
Vref	Input reference voltage value.
Vih(DC)	Input voltage high value (direct current).
Vih(AC)	Input voltage high value (alternating current).
Vil(DC)	Input voltage low value (direct current).
Vil(AC)	Input voltage low value (alternating current).
InfiniiScan Limits	
Read Cycle	
IScan_UL_READ	Identifies the upper limit for Setup Time measurement used in the InfiniiScan Measurement Mode (READ cycle)
IScan_LL_READ	Identifies the lower limit for Setup Time measurement used in the InfiniiScan Measurement Mode (READ cycle)
Write Cycle	
IScan_UL_WRITE	Identifies the upper limit for Setup Time measurement used in the InfiniiScan Measurement Mode (WRITE cycle)
IScan_LL_WRITE	Identifies the lower limit for Setup Time measurement used in the InfiniiScan Measurement Mode (WRITE cycle)
Single-Ended Signals	
Single-Ended AC Parameters	
Pin Under Test, PUT	Identifies the Pin Under Test for Single-Ended AC parameters.
PUT Source	Identifies the source of the PUT to be analyzed for Single-Ended AC tests.
Supporting Pin	Identifies the required supporting pin for Single-Ended AC parameters.
Supporting Pin Source	Identifies the source of the supporting pin for Single-Ended AC Tests.

$V_{OH(AC)}$ Test Method of Implementation

$V_{OH(AC)}$ - Maximum AC Output Logic High. This test is only applied to Low Power DDR SDRAM. The purpose of this test is to verify that the maximum high level voltage value of the test signal within a valid sampling window is greater than the conformance lower limit of the $V_{OH(AC)}$ value specified in the JEDEC Standard JESD79E.

The default value of V_{DDQ} is as shown in Table 18. However, users have the flexibility to change this value.

Table 18 The default value of V_{DDQ}

Speed	DDR 200, 266, 333	DDR 400	Low Power
V_{DDQ}	2.50 V	2.60 V	1.80 V



Figure 14 $V_{OH(AC)}$ Test - Maximum AC Output Logic High in Infiniium oscilloscope.

Signals of Interest

Based on the test definition (Read cycle only):

- Data Signal
- Data Strobe Signal OR
- Address Signal OR
- Control Signal OR
- Data Mask Control Signals

Signals required to perform the test on the oscilloscope:

- Data Signal (DQ as Pin Under Test Signal)*
- Data Strobe Signal (DQS as Supporting Signal)
- Clock Signal - CK is required to perform pre-test to verify the DUT speed against user's speed grade selection

* Pin Under Test signal can be either one of the signals under the test definition.

Test Definition Notes from the Specification

Table 19 Low Power DDR SDRAM Electrical Characteristics

Parameter/Condition	Symbol	Min	Max	Units	Notes
DC Output High Voltage (IOH = -0.1mA)	VOH	0.9 * VDDQ		V	-

PASS Condition

The maximum value for the high level voltage should be greater than or equal to the minimum $V_{OH(AC)}$ value.

Measurement Algorithm

- 1 Calculate the initial time scale value based on the selected DDR1 speed grade options.
- 2 Pre-condition the scope settings. Verify the actual DUT speed against the user speed selection at the Setup page.
- 3 Calculate the number of sampling points according to the time scale value.
- 4 Obtain sample or acquire signal data and perform signal conditioning to maximize the screen resolution (vertical scale adjustment).
- 5 Perform signal checking on all the signals in-use in the measurement to ensure that it can be triggered during the test. This includes V_{p-p} , V_{min} , V_{max} and V_{mid} of each signal.
- 6 Perform signal skew checking on the DQ-DQS to ensure that it can be triggered during the Read/Write separation later.
- 7 Setup the required scope settings and histogram function settings.
- 8 Use the histogram Max value as the test result for $V_{OH(AC)}$.
- 9 When multiple trials are performed, the smallest value (worst case) among the trials will be used as the test result for $V_{OH(AC)}$.
- 10 Compare the test results against the compliance test limits.

Test References

See Table 8 - Low Power DDR SDRAM Electrical Characteristics, in the *JEDEC Standard JESD79E*.

$V_{OL(AC)}$ Test Method of Implementation

$V_{OL(AC)}$ - Minimum AC Output Logic Low. This test is only applied to Low Power DDR SDRAM. The purpose of this test is to verify that the minimum low level voltage value of the test signal is lower than the conformance maximum limit of the $V_{OL(AC)}$ value specified in the *JEDEC Standard JESD79E*.

The default value of V_{DDQ} is as shown in Table 20. However, users have the flexibility to change this value.

Table 20 The default value of V_{DDQ}

Speed	DDR 200, 266, 333	DDR 400	Low Power
V_{DDQ}	2.50 V	2.60 V	1.80 V

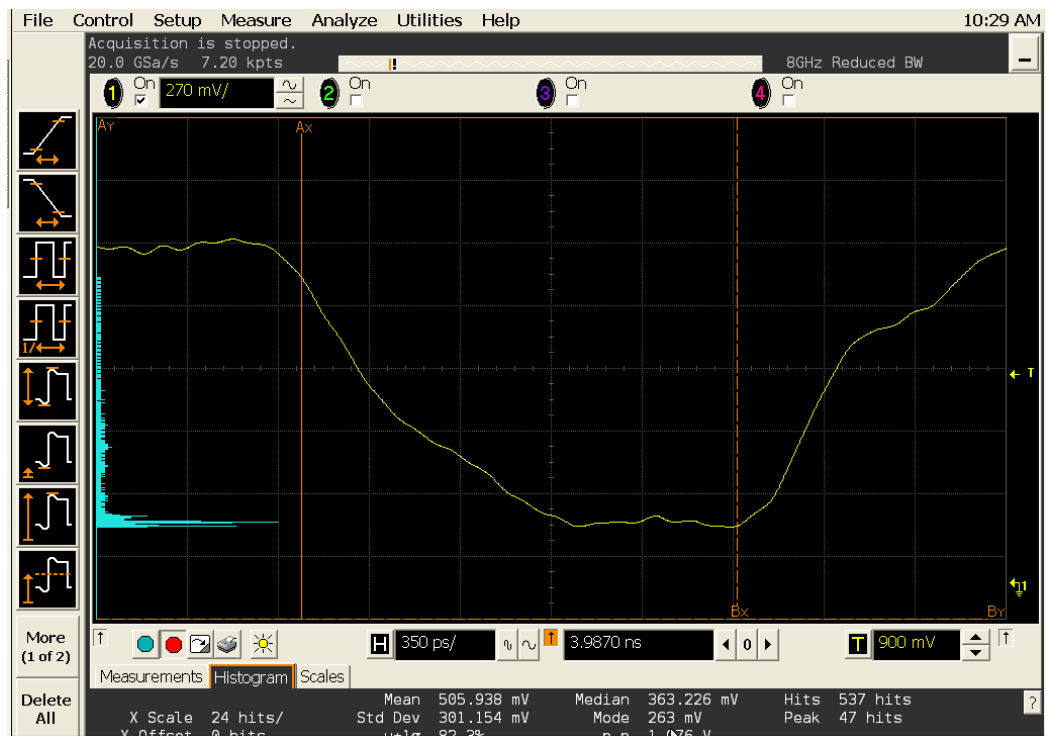

Figure 15 $V_{OL(AC)}$ Test - Minimum AC Output Logic Low in Infiniium oscilloscope

Signals of Interest

Based on the test definition (Read cycle only):

- Data Signal
- Data Strobe Signal OR
- Address Signal OR
- Control Signal OR

Signals required to perform the test on the oscilloscope:

- Data Signal (DQ as Pin Under Test Signal)*

- Data Strobe Signal (DQS as Supporting Signal)
- Clock Signal – CK is required to perform pre-test to verify the DUT speed against user’s speed grade selection

* Pin Under Test signal can be either one of the signals under the test definition.

Test Definition Notes from the Specification

Table 21 Low Power DDR SDRAM Electrical Characteristics

Parameter/Condition	Symbol	Min	Max	Units	Notes
DC Output Low Voltage (IOL = -0.1mA)	VOL	-	0.1 * VDDQ	V	-

PASS Condition

The minimum value for the low level voltage should be less than or equal to the maximum $V_{OL(AC)}$ value.

Measurement Algorithm

- 1 Calculate initial time scale value based on the selected DDR1 speed grade options.
- 2 Pre-condition the scope settings. Verify the actual DUT speed against the user speed selection at the Setup page.
- 3 Calculate the number of sampling points according to the time scale value.
- 4 Obtain sample or acquire signal data and perform signal conditioning to maximize the screen resolution (vertical scale adjustment).
- 5 Perform signal checking on all the signals in-use in the measurements to ensure that it can be triggered during the test. This includes Vp-p, Vmin, Vmax and Vmid of each signal.
- 6 Perform signal skew checking on the DQ-DQS to ensure that it can be triggered during the Read/Write separation later.
- 7 Setup the required scope settings and histogram function settings.
- 8 Use the histogram Min value as the test result for $V_{OL(AC)}$.
- 9 When multiple trials are performed, the largest value (worst case) among the trials will be used as the test result for $V_{OL(AC)}$.
- 10 Compare the test results against the compliance test limits.

Test References

See Table 8 - Low Power DDR SDRAM Electrical Characteristics, in the *JEDEC Standard JESD79E*.

5 Single-Ended Signals Overshoot/Undershoot Tests

Probing for Overshoot/Undershoot Tests / 62
AC Overshoot Test Method of Implementation / 65
AC Undershoot Test Method of Implementation / 68

This section provides the Methods of Implementation (MOIs) for Single-Ended Signals Overshoot/Undershoot tests using an Keysight 54850A, 8000, 80000 or 90000A series Infiniium oscilloscope, recommended InfiniiMax 116xA or 113xA probe amplifiers, E2677A differential solder-in probe head and the DDR1 Compliance Test Application.

Probing for Overshoot/Undershoot Tests

When performing the Single-Ended Signals Overshoot/Undershoot tests, the DDR1 Compliance Test Application will prompt you to make the proper connections as shown in the following diagram. Refer to the Connection tab in DDR1 Compliance Test Application for the exact number of probe connections.

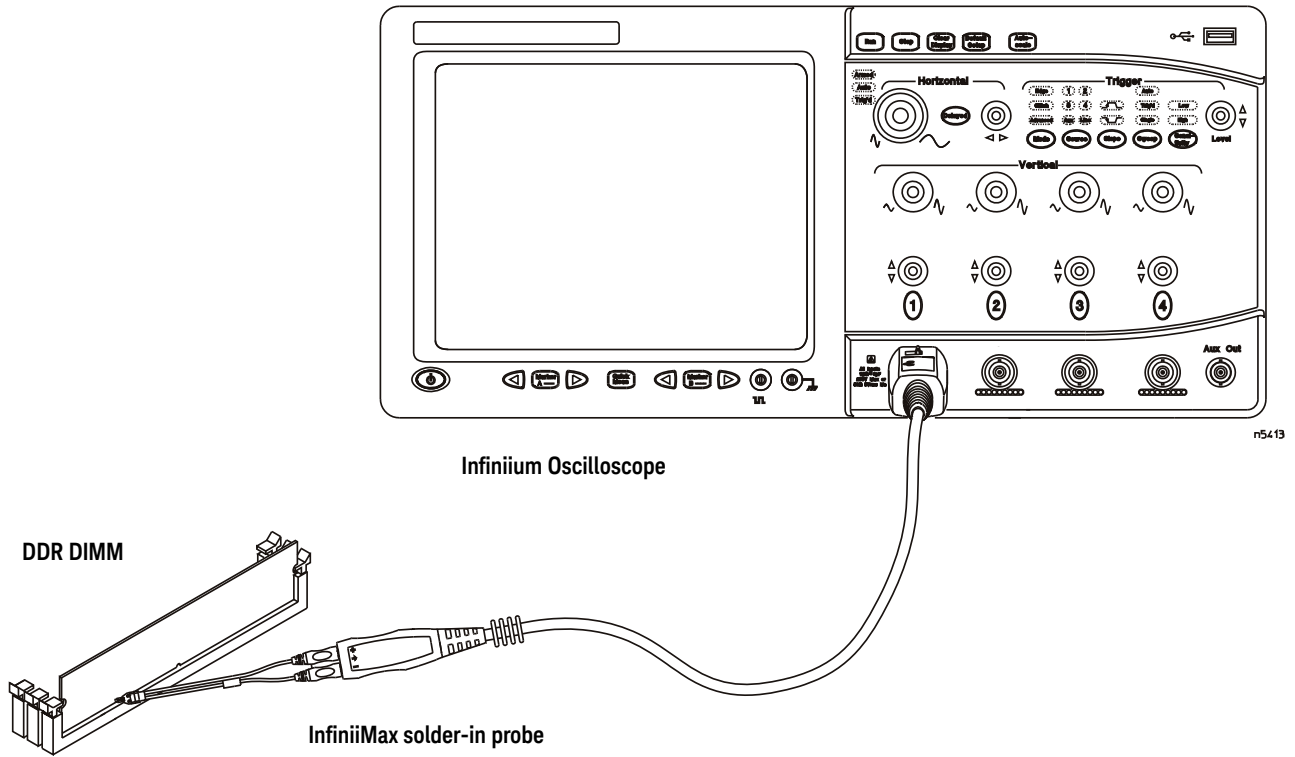

Figure 16 Probing for Single-Ended Signals Overshoot/Undershoot Tests

You can use any of the oscilloscope channels as Pin Under Test (PUT) source channel. You can identify the channels used for each signal in the Configuration tab of the DDR1 Compliance Test Application. (The channel shown in [Figure 16](#) is just an example).

For more information on the probe amplifiers and differential probe heads, see [Chapter 14](#), “InfiniiMax Probing,” starting on page 185.

Test Procedure

- 1 Start the automated test application as described in [“Starting the DDR1 Compliance Test Application”](#) on page 27.
- 2 Ensure that the RAM reliability test software is running on the computer system where the DDR Device Under Test (DUT) is attached. This software will perform a test on all unused RAM on the system by producing a repetitive burst of read-write data signals to the DDR memory.
- 3 Connect the differential solder-in probe head to the PUTs on the DDR DIMM.

- 4 Connect the oscilloscope probes to any channels of the oscilloscope.
- 5 In the DDR1 Test Application, click the Set Up tab.
- 6 Select the Speed Grade options. For the Single-Ended Signals AC Input Parameters Tests, you can select any speed grade within the selection: DDR1-200, DDR1-266, DDR1-333, DDR1-400.
- 7 Type in or select the Device Identifier as well as User Description from the drop-down list. Enter your comments in the Comments text box.
- 8 Click the Select Tests tab and check the tests you want to run. Check the parent node or group to check all the available tests within the group.

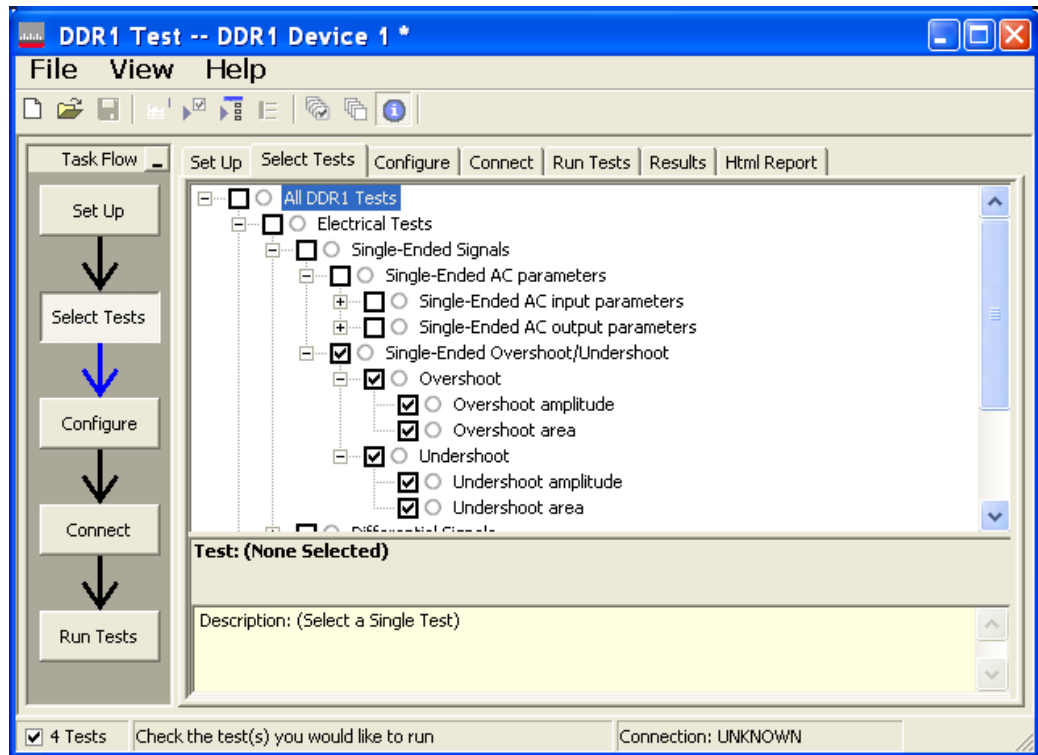

Figure 17 Selecting Single-Ended Signals Overshoot/Undershoot Tests

- 9 Follow the DDR1 Test Application's task flow to set up the configuration options (see [Table 22](#)), run the tests and view the tests results.

Table 22 Test Configuration Options

Configuration Option	Description
Stop on error	Enabling this error message will allow error message to prompt whenever criteria is not met. Disabling this option will allow the system to bypass all the error messages that could occur and continue to the next test. This option is suitable for long hours multiple trial.
Signal Threshold setting by percentage	This option allow user to define the Upper and Lower threshold of the signal by percentage.
VDD	Input supply voltage value.
VDDQ	Input supply voltage for data output.
Vref	Input reference voltage value.
Vih(DC)	Input voltage high value (direct current).
Vih(AC)	Input voltage high value (alternating current).
Vil(DC)	Input voltage low value (direct current).
Vil(AC)	Input voltage low value (alternating current).
InfiniiScan Limits	
Read Cycle	
IScan_UL_READ	Identifies the upper limit for Setup Time measurement used in the InfiniiScan Measurement Mode (READ cycle)
IScan_LL_READ	Identifies the lower limit for Setup Time measurement used in the InfiniiScan Measurement Mode (READ cycle)
Write Cycle	
IScan_UL_WRITE	Identifies the upper limit for Setup Time measurement used in the InfiniiScan Measurement Mode (WRITE cycle)
IScan_LL_WRITE	Identifies the upper limit for Setup Time measurement used in the InfiniiScan Measurement Mode (WRITE cycle)
Single-Ended Signals	
Single-Ended Overshoot/Undershoot	
Pin Under Test, PUT	Identifies the Pin Under Test for Single-Ended Overshoot/Undershoot.
PUT Source	Identifies the source of the PUT to be analyzed for Single-Ended AC tests.

AC Overshoot Test Method of Implementation

The Overshoot test can be divided into two sub-tests: Overshoot amplitude and Overshoot area. The purpose of this test is to verify that the overshoot value of the test signal is lower than or equal to the conformance limit of the maximum peak amplitude allowed for overshoot as specified in the *JEDEC Standard JESD79E*.

When there is an overshoot, the area is calculated based on the overshoot width. The Overshoot area should be lower than or equal to the conformance limit of the maximum Overshoot area allowed as specified in the *JEDEC Standard JESD79E*.

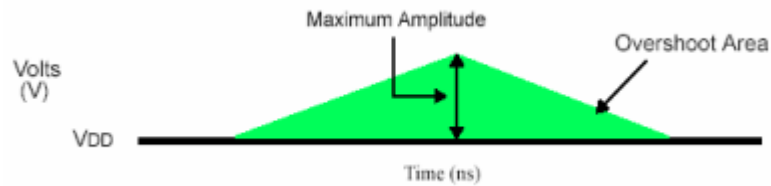

Figure 18 AC Overshoot

Signals of Interest

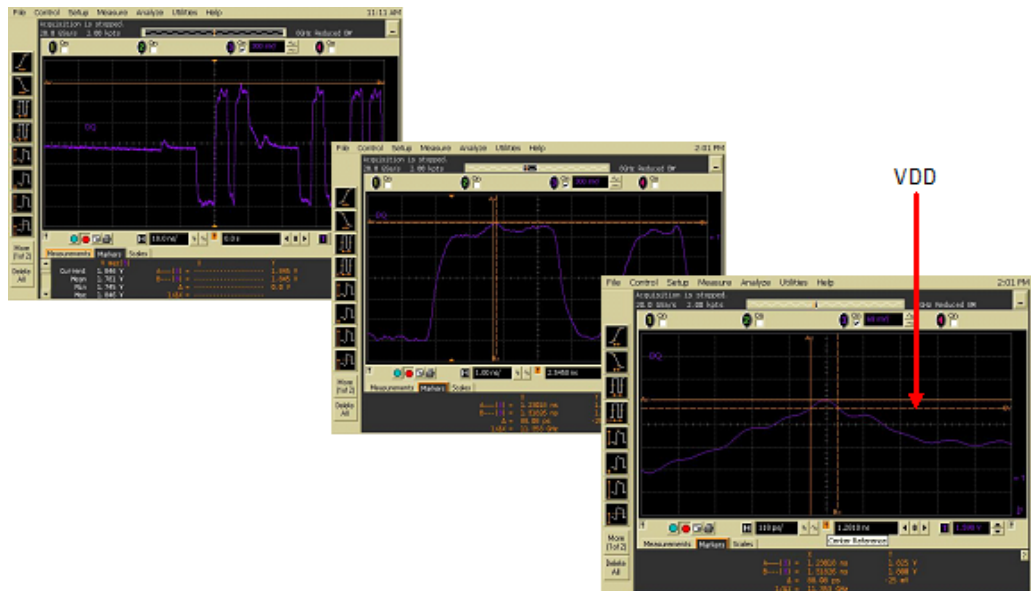

Figure 19 AC Overshoot in Infiniium oscilloscope

Based on the test definition (Write cycle only):

- Data Signal
- Data Strobe Signal OR
- Address Signal OR
- Control Signal OR
- Data Mask Control Signals

Signals required to perform the test on the oscilloscope:

- Data Signal (DQ as Pin Under Test Signal)*
- Data Strobe Signal (DQS as Supporting Signal)
- Clock Signal - CK is required to perform pre-test to verify the DUT speed against user's speed grade selection

* Pin Under Test signal can be either one of the signals under the test definition.

Test Definition Notes from the Specification

Table 23 AC Overshoot/Undershoot Specification for Address and Control Pins

Parameter	Specification	
	DDR 333	DDR 200/266
Maximum peak amplitude allowed for overshoot	TBD	1.5 V
Maximum peak amplitude allowed for undershoot	TBD	1.5 V
The area between the overshoot signal and VDD must be less than or equal to	TBD	4.5 V-ns
The area between the undershoot signal and GND must be less than or equal to	TBD	4.5 V-ns

Table 24 AC Overshoot/Undershoot Specification for Clock, Data, Strobe and Mask Pins

Parameter	Specification	
	DDR 333	DDR 200/266
Maximum peak amplitude allowed for overshoot	TBD	1.2 V
Maximum peak amplitude allowed for undershoot	TBD	1.2 V
The area between the overshoot signal and VDD must be less than or equal to	TBD	2.4 V-ns
The area between the undershoot signal and GND must be less than or equal to	TBD	2.4 V-ns

PASS Condition

The measured maximum voltage value can be less than or equal to the maximum overshoot value.

The calculated Overshoot area value can be less than or equal to the maximum Overshoot area allowed.

Measurement Algorithm

- 1 Set the number of sampling points to 2M samples.
- 2 Pre-condition the scope settings. Verify the actual DUT speed against the user speed selection at the Setup page.
- 3 Calculate initial time scale value based on the number of sampling points.
- 4 Obtain sample or acquire signal data and perform signal conditioning to maximize the screen resolution (vertical scale adjustment).
- 5 Perform signal checking on all the signals in-use in the measurement to ensure that it can be triggered during the test. This includes Vp-p, Vmin, Vmax and Vmid of each signal.
- 6 Perform signal skew checking on the DQ-DQS to ensure that it can be triggered during the Read/Write separation later.
- 7 Initialize the scope settings.

- 8 Get timestamp of maximum peak voltage on the waveform.
- 9 Perform manual zoom waveform to maximum peak area.
- 10 Get the timestamp of voltage value for VDD(-1.8 V) level closest to the peak point value in order to calculate the maximum overshoot length duration.
- 11 Calculate the Overshoot area (V-ns)
 - a Area of calculation is based on the area of calculation of a triangle where the Overshoot width is used as the triangle base and the Overshoot amplitude is used as the triangle height.
 - b $\text{Area} = 0.5 * \text{base} * \text{height}$.
- 12 When multiple trials are performed, the largest value (worst case) among all the trials will be used as the test result for the Overshoot amplitude and Overshoot area. The worst case for the area might not happen during the worst case for the amplitude.
- 13 Compare the test results against the compliance test limits.

Test References

See Table 20 - AC Overshoot/Undershoot Specification for Address and Control Pins, and Table 21 - AC Overshoot/Undershoot Specification for Data, Strobe and Mask Pins, in the *JEDEC Standard JESD79E*.

AC Undershoot Test Method of Implementation

The Undershoot Test can be divided into two sub-tests: Undershoot amplitude and Undershoot area. The purpose of this test is to verify that the undershoot value of the test signal is less than or equal to the conformance limit of the maximum peak amplitude allowed for undershoot as specified in the *JEDEC Standard JESD79E*.

When there is an undershoot, the area is calculated based on the undershoot width. The Undershoot area should be less than or equal to the conformance limit of the maximum undershoot area allowed as specified in the *JEDEC Standard JESD79E*.

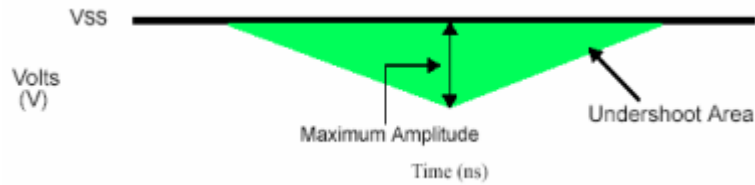

Figure 20 AC Undershoot

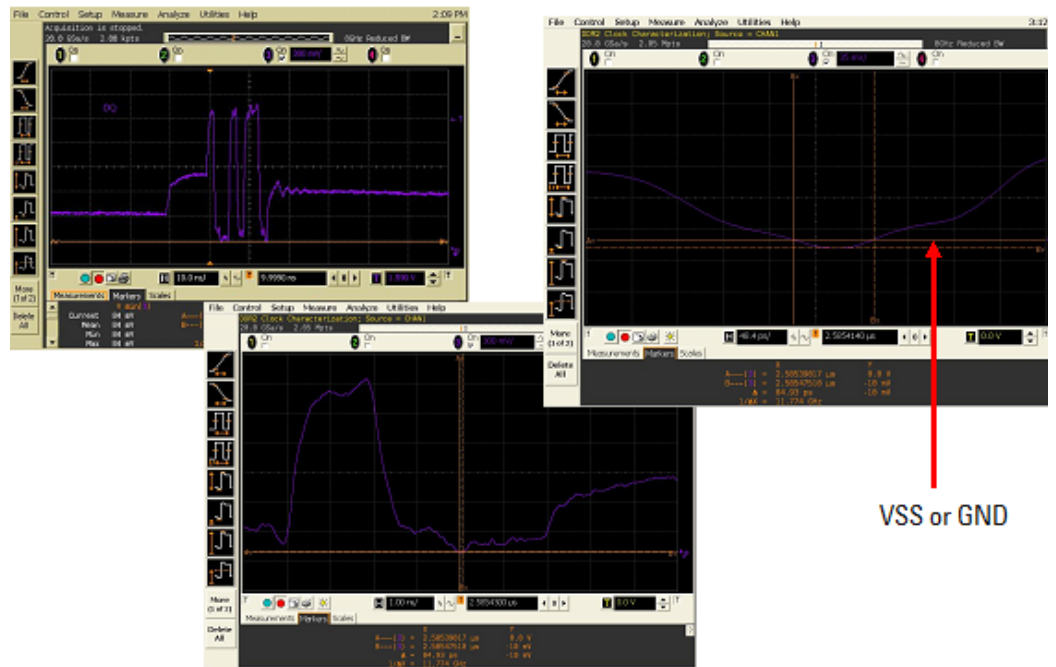

Figure 21 AC Undershoot in Infiniium oscilloscope.

Signals of Interest

Based on the test definition (Write cycle only):

- Data Signal
- Data Strobe Signal OR
- Address Signal OR
- Control Signal OR

- Data Mask Control Signals

Signals required to perform the test on the oscilloscope:

- Data Signal (DQ as Pin Under Test Signal)*
- Data Strobe Signal (DQS as Supporting Signal)
- Clock Signal - CK is required to perform pre-test to verify the DUT speed against user's speed grade selection

* Pin Under Test signal can be either one of the signals under the test definition.

Test Definition Notes from the Specification

Table 25 AC Overshoot/Undershoot Specification for Address and Control Pins

Parameter	Specification	
	DDR 333	DDR 200/266
Maximum peak amplitude allowed for overshoot	TBD	1.5 V
Maximum peak amplitude allowed for undershoot	TBD	1.5 V
The area between the overshoot signal and VDD must be less than or equal to	TBD	4.5 V-ns
The area between the undershoot signal and GND must be less than or equal to	TBD	4.5 V-ns

Table 26 AC Overshoot/Undershoot Specification for Clock, Data, Strobe and Mask Pins

Parameter	Specification	
	DDR 333	DDR 200/266
Maximum peak amplitude allowed for overshoot	TBD	1.2 V
Maximum peak amplitude allowed for undershoot	TBD	1.2 V
The area between the overshoot signal and VDD must be less than or equal to	TBD	2.4 V-ns
The area between the undershoot signal and GND must be less than or equal to	TBD	2.4 V-ns

PASS Condition

The measured minimum voltage value for the test signal can be less than or equal to the maximum undershoot value.

The calculated undershoot area value can be less than or equal to the maximum undershoot area allowed.

Measurement Algorithm

- 1 Set the number of sampling points to 2M samples.
- 2 Pre-condition the scope settings. Verify the actual DUT speed against the user speed selection at the Setup page.
- 3 Calculate initial time scale value based on the number of sampling points.
- 4 Obtain sample or acquire signal data and perform signal conditioning to maximize the screen resolution (vertical scale adjustment).
- 5 Perform signal checking on all the signals in-use in the measurement to ensure that it can be triggered during the test. This includes Vp-p, Vmin, Vmax and Vmid of each signal.

- 6 Perform signal skew checking on the DQ-DQS to ensure that it can be triggered during the Read/Write separation later.
- 7 Initialize the scope settings.
- 8 Get timestamp of minimum peak voltage on the waveform.
- 9 Perform manual zoom waveform to minimum peak area.
- 10 Get timestamp of voltage value for GND (0 V) level closest to the minimum peak point value in order to calculate the undershoot length duration.
- 11 Calculate the Undershoot area (V-ns)
 - a Area of calculation is based on the area of calculation of a triangle where the undershoot width is used as the triangle base and the undershoot amplitude is used as the triangle height.
 - b $\text{Area} = 0.5 * \text{base} * \text{height}$.
- 12 When multiple trials are performed, the largest value (worst case) among all the trials will be used as the test result for the Undershoot amplitude and Undershoot area. The worst case for the area might not happen during the worst case for the amplitude.
- 13 Compare test results against the compliance test limits.

Test References

See Table 20 - AC Overshoot/Undershoot Specification for Address and Control Pins, and Table 21 - AC Overshoot/Undershoot Specification for Data, Strobe and Mask Pins, in the *JEDEC Standard JESD79E*.

6 Differential Signals AC Input Parameters Tests

Probing for Differential Signals AC Input Parameters Tests / 72

VID(AC), AC Differential Input Voltage - Test Method of Implementation / 75

VIX(AC), AC Differential Input Cross Point Voltage -Test Method of Implementation / 78

This section provides the Methods of Implementation (MOIs) for Differential Signals AC Input tests using an Keysight 54850A, 8000, 80000 or 90000A series Infiniium oscilloscope, recommended InfiniMax 116xA or 113xA probe amplifiers, E2677A differential solder-in probe head and the DDR1 Compliance Test Application.

Probing for Differential Signals AC Input Parameters Tests

When performing the Differential Signals AC Input Parameters tests, the DDR1 Compliance Test Application will prompt you to make the proper connections. The connection for the Differential Signals AC Input Parameters tests may look similar to the following diagram. Refer to the Connection tab in DDR1 Compliance Test Application for the exact number of probe connections.

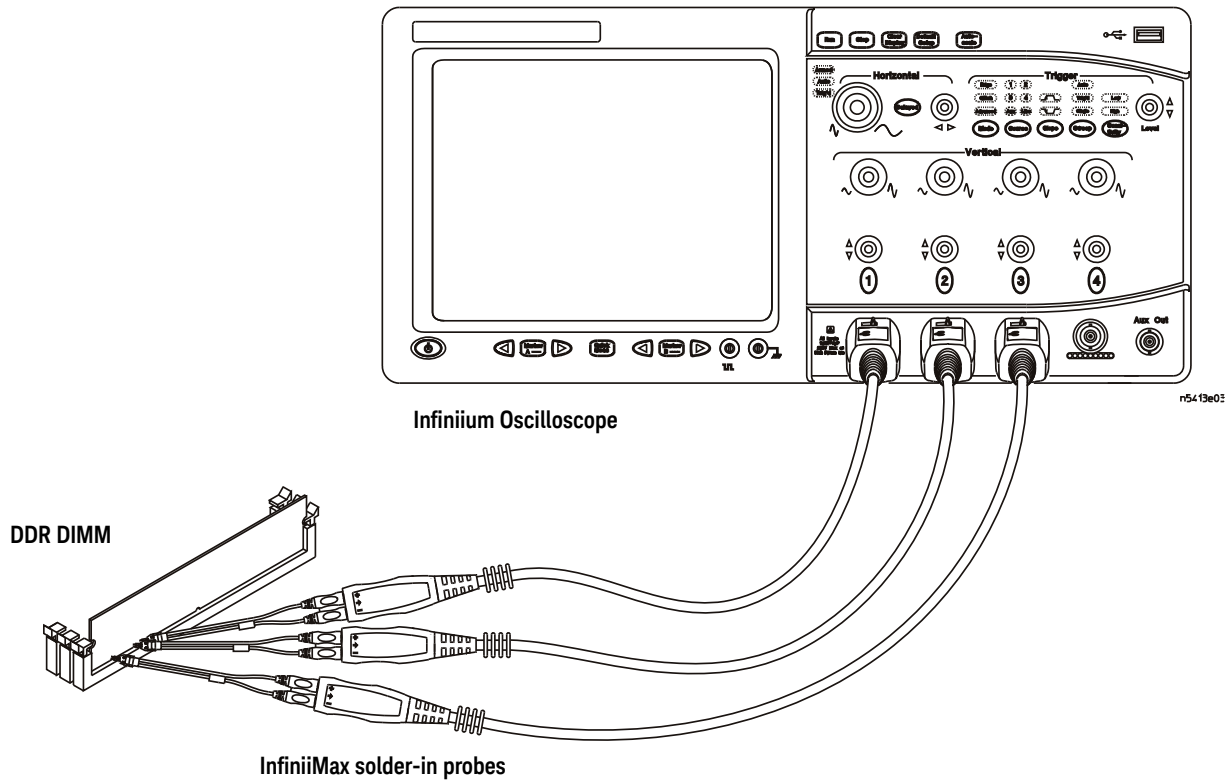

Figure 22 Probing for Differential Signals AC Input Parameters Tests with Three Probes

You can use any of the oscilloscope channels as Pin Under Test (PUT) source channel. You can identify the channels used for each signal in the Configuration tab of the DDR1 Compliance Test Application. (The channels shown in [Figure 22](#) are just examples).

For more information on the probe amplifiers and differential probe heads, see [Chapter 14](#), “InfiniMax Probing,” starting on page 185.

Test Procedure

- 1 Start the automated test application as described in [“Starting the DDR1 Compliance Test Application”](#) on page 27.
- 2 Ensure that the RAM reliability test software is running on the computer system where the DDR Device Under Test (DUT) is attached. This software will perform a test on all unused RAM on the system by producing a repetitive burst of read-write data signals to the DDR memory.

- 3 Connect the differential solder-in probe head to the PUTs on the DDR DIMM.
- 4 Connect the oscilloscope probes to any channels of the oscilloscope.
- 5 In the DDR1 Test Application, click the Set Up tab.
- 6 Select the Speed Grade options. For the Single-Ended Signals AC Input Parameters Tests, you can select any speed grade within the selection: DDR1-200, DDR1-266, DDR1-333, DDR1-400.
- 7 Type in or select the Device Identifier as well as User Description from the drop-down list. Enter your comments in the Comments text box.
- 8 Click the Select Tests tab and check the tests you want to run. Check the parent node or group to check all the available tests within the group.

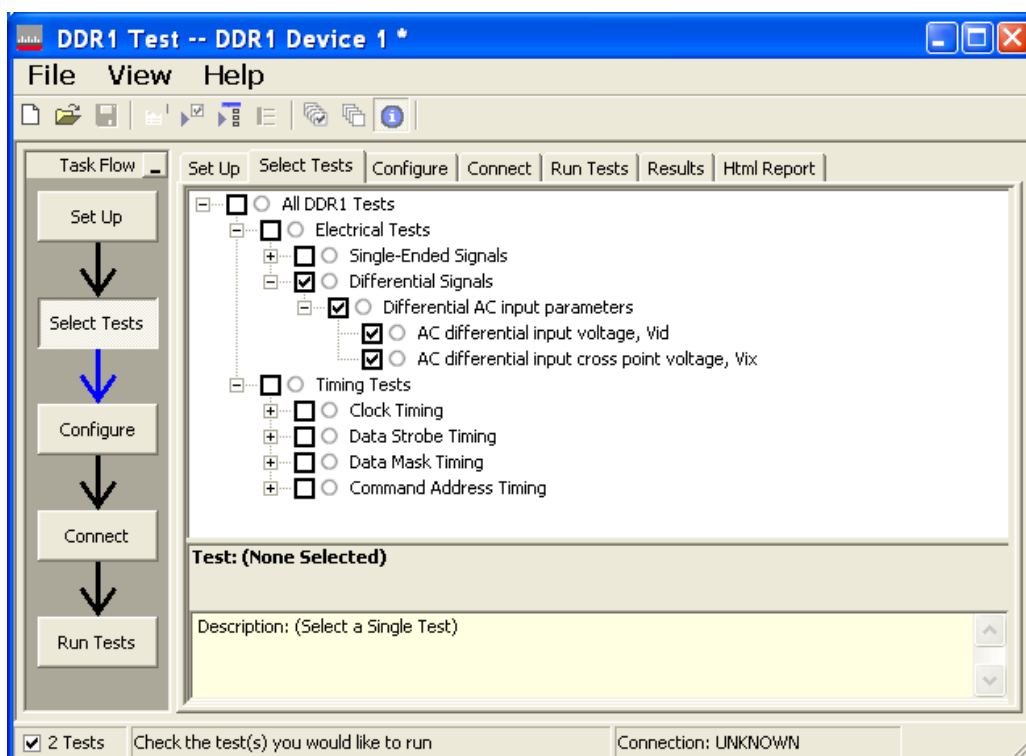

Figure 23 Selecting Differential Signals AC Input Parameters Tests

- 9 Follow the DDR1 Test Application's task flow to set up the configuration options (see [Table 27](#)), run the tests and view the tests results.

Table 27 Test Configuration Options

Configuration Option	Description
Stop on error	Enabling this error message will allow error message to prompt whenever criteria is not met. Disabling this option will allow the system to bypass all the error messages that could occur and continue to the next test. This option is suitable for long hours multiple trial.
Signal Threshold setting by percentage	This option allow user to define the Upper and Lower threshold of the signal by percentage.
VDD	Input supply voltage value.
VDDQ	Input supply voltage for data output.
Vref	Input reference voltage value.
Vih(DC)	Input voltage high value (direct current).
Vih(AC)	Input voltage high value (alternating current).
Vi(DC)	Input voltage low value (direct current).
Vi(AC)	Input voltage low value (alternating current).
InfiniiScan Limits	
Read Cycle	
IScan_UL_READ	Identifies the upper limit for Setup Time measurement used in the InfiniiScan Measurement Mode (READ cycle)
IScan_LL_READ	Identifies the lower limit for Setup Time measurement used in the InfiniiScan Measurement Mode (READ cycle)
Write Cycle	
IScan_UL_WRITE	Identifies the upper limit for Setup Time measurement used in the InfiniiScan Measurement Mode (WRITE cycle)
IScan_LL_WRITE	Identifies the upper limit for Setup Time measurement used in the InfiniiScan Measurement Mode (WRITE cycle)
Differential Tests	
Pin Under Test, PUT	Identifies the Pin Under Test for Differential AC parameters.
PUT (+) Source	Identifies the source of the PUT(+) for Differential AC tests.
PUT (-) Source	Identifies the source of the PUT(-) for Differential AC tests.
Supporting Pin	Identifies the required supporting pin for Differential AC parameters.
Supporting Pin Source	Identifies the source of the supporting pin for Differential AC tests.

$V_{ID(AC)}$, AC Differential Input Voltage - Test Method of Implementation

The purpose of this test is to verify that the magnitude difference between the differential input signals pair is within the conformance limits of the $V_{ID(AC)}$ as specified in the *JEDEC Standard JESD79E*.

The default value of V_{DDQ} is as shown in [Table 28](#). However, users have the flexibility to change this value.

Table 28 The default value of V_{DDQ}

Speed	DDR 200, 266, 333	DDR 400	Low Power
V_{DDQ}	2.50 V	2.60 V	1.80 V

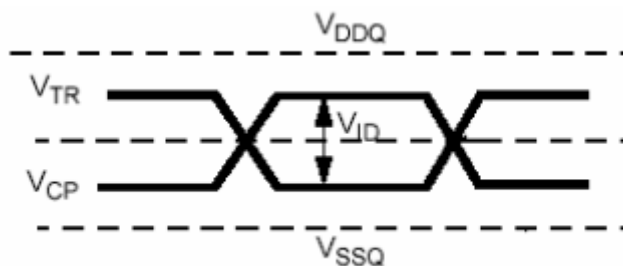

Figure 24 V_{ID} AC Differential Input Voltage

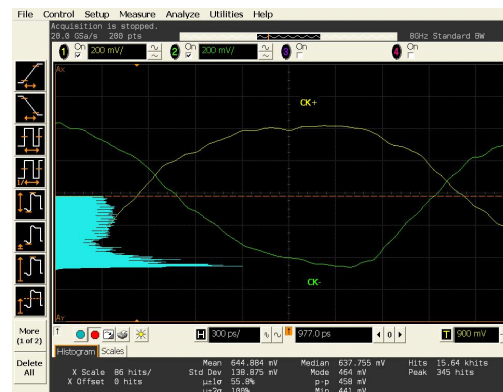
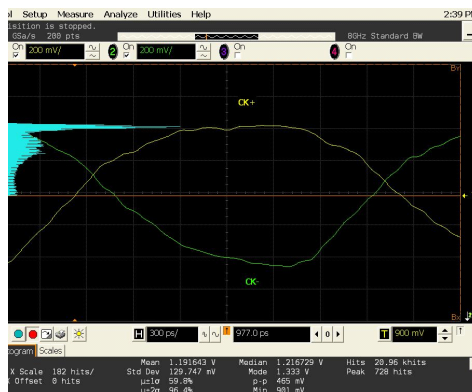
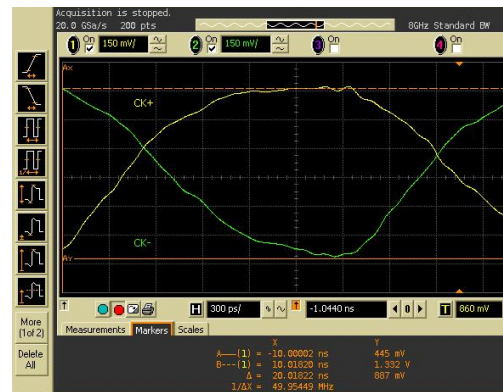
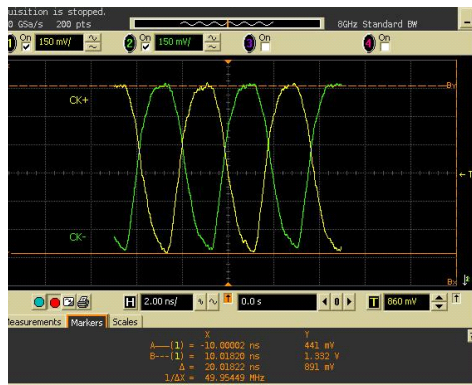

Figure 25 $V_{ID(AC)}$ in Infiniium oscilloscope.

Signals of Interest

Based on the test definition (Write cycle only):

- Clock Signal

Signals required to perform the test on the oscilloscope:

- Clock Signal - CK is required to perform pre-test to verify the DUT speed against user's speed grade selection

Test Definition Notes from the Specification

Table 29 AC Operating Conditions

Parameter	Symbol	Min	Max	Units	Notes
Input Differential Voltage, CK and CK# inputs	$V_{ID(AC)}$	0.7	$V_{DDQ} + 0.6$	V	9

NOTE 9: V_{ID} is the magnitude of the difference between the input level on CK and the input level on CK#.

PASS Condition

The calculated magnitude of the differential voltage for the test signals pair can be within the conformance limits of the $V_{ID(AC)}$ value.

Measurement Algorithm

- 1 Pre-condition the scope settings. Verify the actual DUT speed against the user speed selection at the Setup page.
- 2 Obtain sample or acquire signal data and perform signal conditioning to maximize the screen resolution (vertical scale adjustment).
- 3 Perform signal checking on all the signals in-use in the measurement to ensure that it can be triggered during the test. This includes V_{p-p} , V_{min} , V_{max} and V_{mid} of each signal.
- 4 Perform signal skew checking on the DQ-DQS to ensure that it can be triggered during the Read/Write separation later.
- 5 Obtain sample or acquire data waveforms, for example CK+ and CK-.
- 6 Use histogram function (mode value) to find the nominal high level value for CK+ and nominal low level value for CK-.
- 7 Subtract the CK- low level value from the CK+ high level value.
- 8 Compare the test results against the compliance test limits.

Test References

See Table 7 - AC Operating Conditions, in the *JEDEC Standard JESD79E*.

$V_{IX(AC)}$, AC Differential Input Cross Point Voltage -Test Method of Implementation

The purpose of this test is to verify the crossing point of the input differential test signals pair is within the conformance limits of the $V_{IX(AC)}$ as specified in the JEDEC Standard JESD79E.

The default value of V_{DDQ} is as shown in Table 30. However, users have the flexibility to change this value.

Table 30 The default value of V_{DDQ}

Speed	DDR 200, 266, 333	DDR 400	Low Power
V_{DDQ}	2.50 V	2.60 V	1.80 V

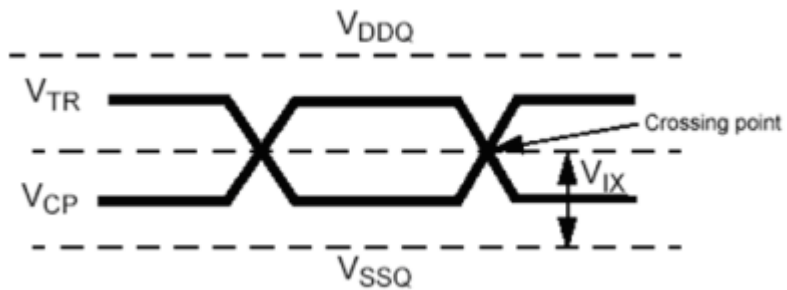

Figure 26 V_{IX} AC Differential Input Voltage

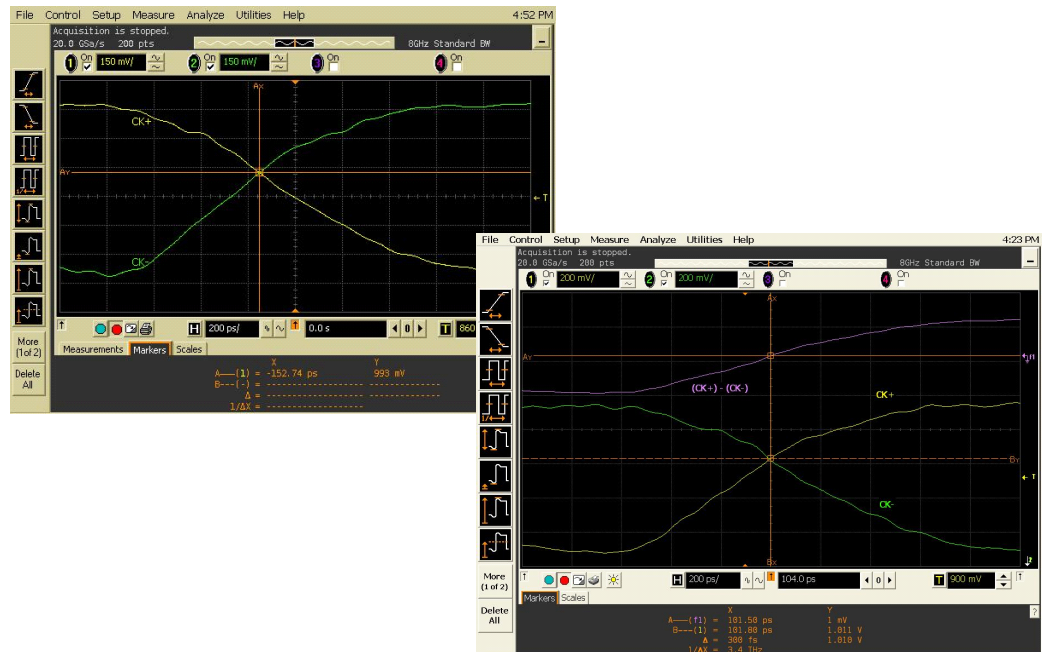

Figure 27 $V_{IX(AC)}$ in Infiniium oscilloscope

Signals of Interest

Based on the test definition (Write cycle only):

- Clock Signal

Signals required to perform the test on the oscilloscope:

- Clock Signal - CK is required to perform pre-test to verify the DUT speed against user's speed grade selection

Test Definition Notes from the Specification

Table 31 AC Operating Conditions

Parameter	Symbol	Min	Max	Units	Notes
Input Differential Voltage, CK and CK# inputs	$V_{IX(AC)}$	$0.5 * V_{DDQ} - 0.2$	$0.5 * V_{DDQ} + 0.2$	V	10

NOTE 10: The value of V_{ID} is the magnitude of the difference between the input level on CK and the input level on CK#.

PASS Condition

The measured crossing point value for the differential test signals pair can be within the conformance limits of $V_{IX(AC)}$ value.

Measurement Algorithm

- 1 Pre-condition the scope settings. Verify the actual DUT speed against the user speed selection at the Setup page.
- 2 Obtain sample or acquire signal data and perform signal conditioning to maximize the screen resolution (vertical scale adjustment).
- 3 Perform signal checking on all the signals in-use in the measurement to ensure that it can be triggered during the test. This includes V_{p-p} , V_{min} , V_{max} and V_{mid} of each signal.
- 4 Perform signal skew checking on the DQ-DQS to ensure that it can be triggered during the Read/Write separation later.
- 5 Obtain sample or acquire data waveforms, for example CK+ and CK-.
- 6 Generate the differential waveform from two source input.
- 7 Get the timestamp of voltage value = 0 V level (crossing point).
- 8 Get the actual crossing value using the obtained timestamp.
- 9 Compare the test results against the compliance test limits.

Test References

See Table 7 - AC Operating Conditions, in the *JEDEC Standard JESD79E*.

7 Data Strobe Timing (DST) Tests

Probing for Data Strobe Timing Tests / 82

tHZ(DQ), DQ High Impedance Time From CK/CK# - Test Method of Implementation / 85

tHZ(DQS), DQS High Impedance Time From CK/CK# - Test Method of Implementation / 87

tLZ(DQS), DQS Low-Impedance Time from CK/CK# - Test Method of Implementation / 89

tLZ(DQ), DQ Low-Impedance Time from CK/CK# - Test Method of Implementation / 91

tDQSQ, DQS-DQ Skew for DQS and Associated DQ Signals - Test Method of Implementation / 94

tQH, DQ/DQS Output Hold Time From DQS - Test Method of Implementation / 96

tDQSS, DQS Latching Transition to Associated Clock Edge - Test Method of Implementation / 98

tDQSH, DQS Input High Pulse Width - Test Method of Implementation / 100

tDQSL, DQS Input Low Pulse Width - Test Method of Implementation / 102

tDSS, DQS Falling Edge to CK Setup Time - Test Method of Implementation / 104

tDSH, DQS Falling Edge Hold Time from CK - Test Method of Implementation / 106

tWPST, Write Postamble - Test Method of Implementation / 108

tWPPE, Write Preamble - Test Method of Implementation / 110

tRPPE, Read Preamble - Test Method of Implementation / 112

tRPST, Read Postamble - Test Method of Implementation / 114

This section provides the Methods of Implementation (MOIs) for Data Strobe Timing tests using an Keysight 54850A, 8000, 80000 or 90000A series Infiniium oscilloscope, recommended InfiniiMax 116xA or 113xA probe amplifiers, E2677A differential solder-in probe head and the DDR1 Compliance Test Application.

NOTE

Both XYZ# and $\overline{\text{XYZ}}$ are referring to compliment. Thus, CK# is the same as $\overline{\text{CK}}$.

Probing for Data Strobe Timing Tests

When performing the Data Strobe Timing tests, the DDR1 Compliance Test Application will prompt you to make the proper connections. The connection for Data Strobe Timing tests may look similar to the following diagram. Refer to the Connection tab in DDR1 Compliance Test Application for the exact number of probe connections. Typically, you need minimum three probe connections to run the tests.

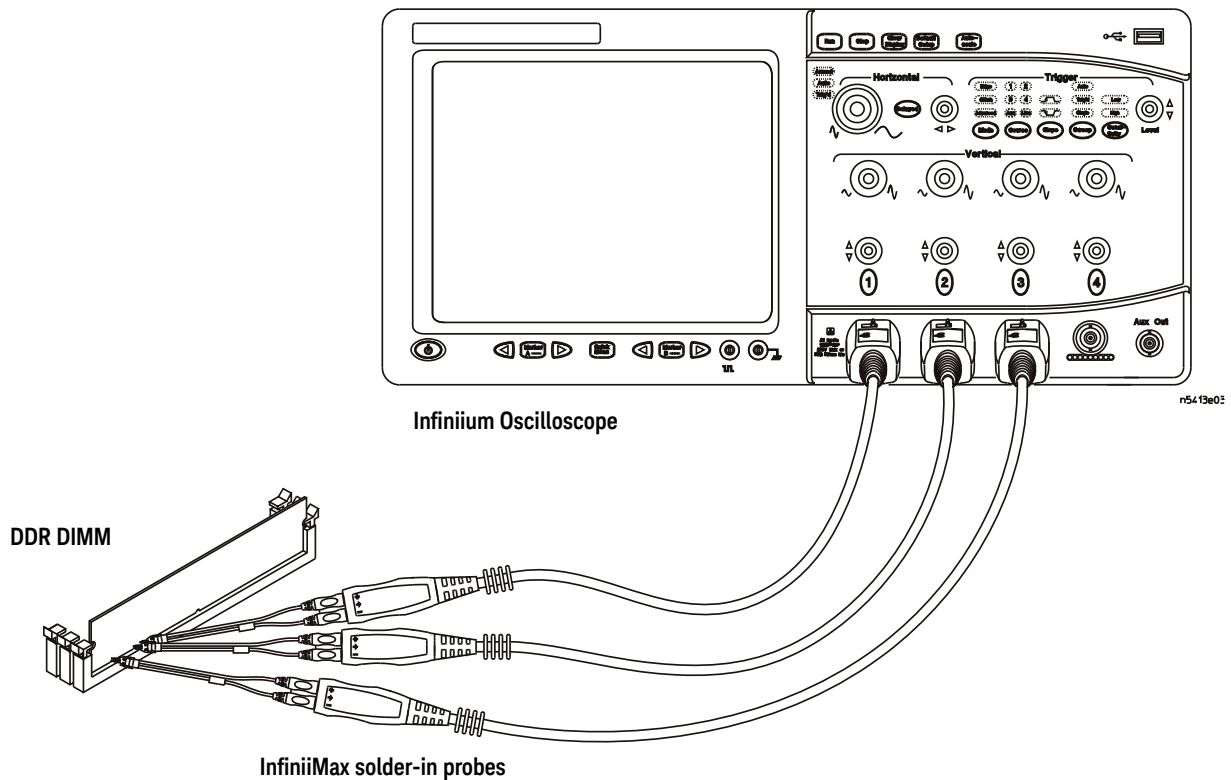

Figure 28 Probing for Data Strobe Timing Tests with Three Probes

You can use any of the oscilloscope channels as Pin Under Test (PUT) source channel. You can identify the channels used for each signal in the Configuration tab of the DDR1 Compliance Test Application. (The channels shown in [Figure 28](#) are just examples).

For more information on the probe amplifiers and differential probe heads, see [Chapter 14](#), “InfiniMax Probing,” starting on page 185.

Test Procedure

- 1 Start the automated test application as described in [“Starting the DDR1 Compliance Test Application”](#) on page 27.
- 2 Ensure that the RAM reliability test software is running on the computer system where the DDR Device Under Test (DUT) is attached. This software will perform a test on all unused RAM on the system by producing a repetitive burst of read-write data signals to the DDR memory.

- 3 Connect the differential solder-in probe head to the PUTs on the DDR DIMM.
- 4 Connect the oscilloscope probes to any channels of the oscilloscope.
- 5 In the DDR1 Test Application, click the Set Up tab.
- 6 Select the Speed Grade options. For the Single-Ended Signals AC Input Parameters Tests, you can select any speed grade within the selection: DDR1-200, DDR1-266, DDR1-333, DDR1-400.
- 7 Type in or select the Device Identifier as well as User Description from the drop-down list. Enter your comments in the Comments text box.
- 8 Click the Select Tests tab and check the tests you want to run. Check the parent node or group to check all the available tests within the group.

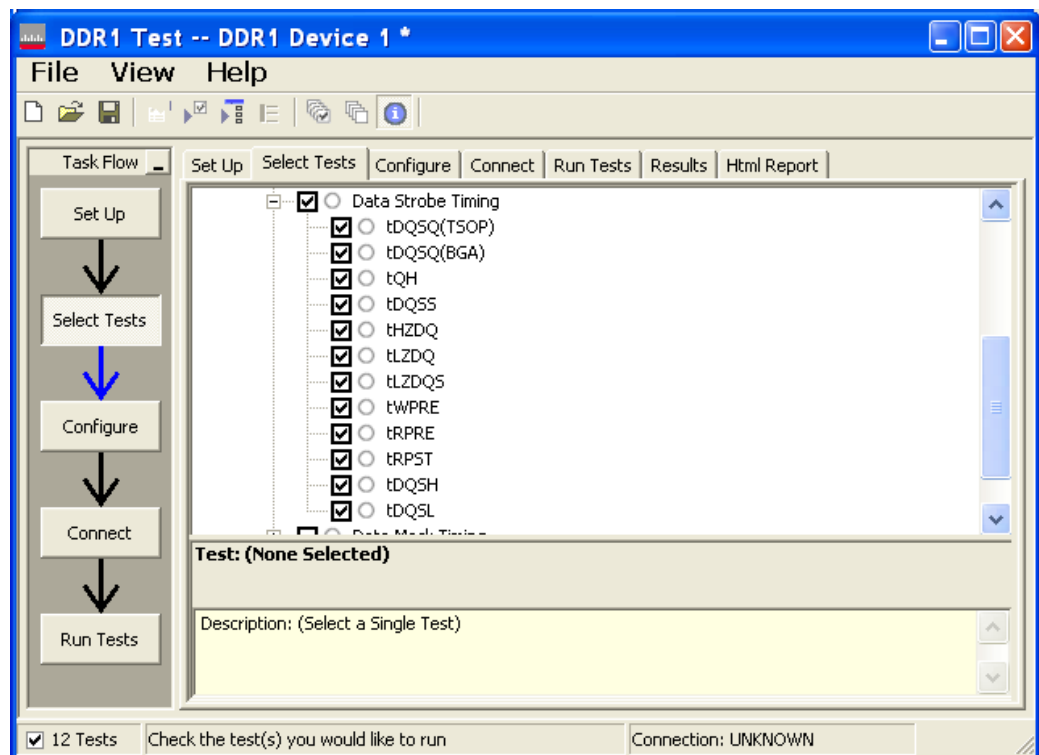

Figure 29 Selecting Data Strobe Timing Tests

- 9 Follow the DDR1 Test application's task flow to set up the configuration options (see [Table 32](#)), run the tests and view the tests results.

Table 32 Test Configuration Options

Configuration Option	Description
Stop on error	Enabling this error message will allow error message to prompt whenever criteria is not met. Disabling this option will allow the system to bypass all the error messages that could occur and continue to the next test. This option is suitable for long hours multiple trial.
Signal Threshold setting by percentage	This option allow user to define the Upper and Lower threshold of the signal by percentage.
VDD	Input supply voltage value.
VDDQ	Input supply voltage for data output.
Vref	Input reference voltage value.
Vih(DC)	Input voltage high value (direct current).
Vih(AC)	Input voltage high value (alternating current).
Vil(DC)	Input voltage low value (direct current).
Vil(AC)	Input voltage low value (alternating current).
Timing Tests	
Total Bit Display	Allows user to select the number of data bits to be displayed at the end of the test. Selecting more bits gives a better view of the entire burst of signals.
Verify Selected Rank Only?	If you choose Yes, you require an additional channel for the Chip Select (CS). Measurement will only be done on the selected rank based on the Chip Select signal connected to the oscilloscope.
Channel (1,2,3)	Signal connected to the specific channel.
Pin Under Test, PUT	Signal used for testing.

tHZ(DQ), DQ High Impedance Time From CK/CK# - Test Method of Implementation

The purpose of this test is to verify that the time when the DQ is no longer driving (from high state OR low state to the high impedance stage), to the clock signal crossing, is within the conformance limits as specified in the *JEDEC Standard JESD79E*.

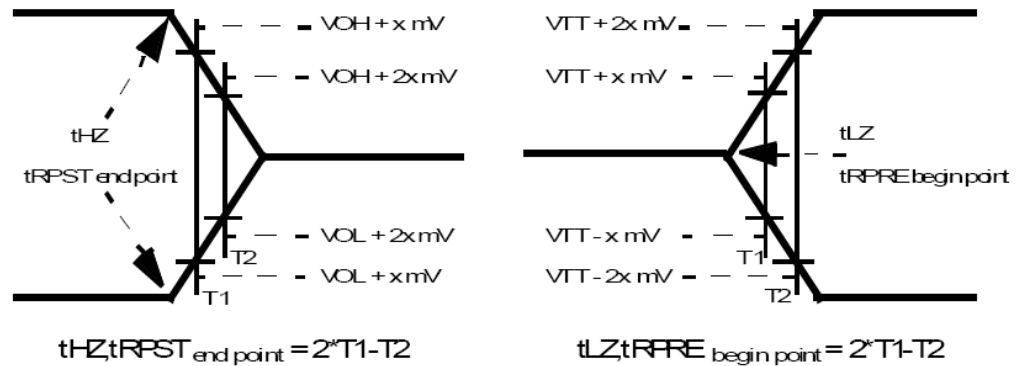

Figure 30 Method for Calculating Transitions and Endpoints

Signals of Interest

Based on the test definition (Read cycle only):

- Data Signal (DQ as Pin Under Test Signal)
- Clock Signal (CK as Reference Signal)

Signals required to perform the test on the oscilloscope:

- Data Signal (DQ as Pin Under Test Signal)
- Data Strobe Signal (DQS as Supporting Signal)
- Clock Signal (CK as Reference Signal)

Optional signal required to separate the signals for the different Ranks:

- Chip Select Signal (\overline{CS} as additional signal, which requires an additional channel)

Test Definition Notes from the Specification

Table 33 Electrical Characteristics and AC Timing

AC Characteristics Parameter	Symbol	DDR 333		DDR 266		DDR 200		Units	Notes
		Min	Max	Min	Max	Min	Max		
DQ & DQS high-impedance time from CK/CK#	tHZ		+0.7		+0.7		+0.7	ns	15

AC Characteristics Parameter	Symbol	DDR 400A (2.5-3-3)		DDR 400B (3-3-3)		DDR 400C (3-4-4)		Units	Notes
		Min	Max	Min	Max	Min	Max		
DQ & DQS high-impedance time from CK/CK#	tHZ		+0.7		+0.7		+0.7	ns	15

NOTE 15: tHZ and tLZ transitions occurs in the same access time as valid data transitions. These parameters are referenced to a specific voltage level which specifies when the device output is no longer driving (tHZ), or begin driving (tLZ). Figure 30 shows a method to calculate the point when device is no longer driving (tHZ), or begins driving (tLZ) by measuring the signal at two different voltages. The actual voltage measurement points are not critical as long as the calculation is consistent.

PASS Condition

The measured time interval from the point where the DQ starts to transit from high/low state to high impedance state, to the clock signal crossing point should be within the specification limit.

Measurement Algorithm

- 1 Obtain the parameters and settings from the Configuration page.
- 2 Pre-condition the scope settings. Verify the actual DUT speed against the user speed selection at the Setup page.
- 3 Perform signal checking on all the signals in-use in the measurement to ensure that it can be triggered during the test. This includes Vp-p, Vmin, Vmax and Vmid of each signal.
- 4 Perform signal skew checking on the DQ-DQS to ensure that it can be triggered during the Read/Write separation later.
- 5 Chip Select (\overline{CS}) option is only applicable if the user has selected “Yes” for the Verify Selected Rank Only option in the Configuration page. It uses the CS-DQS for signal separation. Else, by default, the DQS-DQ is used for signal separation.
- 6 Use the InfiniiScan feature with the Setup time and Hold time to find and capture the Read cycle.
- 7 If you have selected the \overline{CS} option, skip the next step and go to step 9.
- 8 Search for the DQS preamble towards the right from the point where the Read cycle was previously captured. The For loops, TEdge and Delta Time are used to search the preamble.
- 9 Once the preamble is located, call the “BinaryEdgeNormal” function, using Clock as the reference to define the Histogram Window for the DQ signal.
- 10 The Histogram Window is required to cover the DQ signal from the high/low state to the moment it starts to turn off the driver into tristate.
- 11 Setup the threshold value and measurement point for the DQ signal based on the histogram result.
- 12 Once all the points are obtained, proceed with the trigonometry calculation to find the point where the DQ starts to transit from high/low to the time when it turned off its driver into tristate.
- 13 Assign marker A for the clock signal crossing point while marker B for the data signal start to turn off its driver.
- 14 Measure delta of marker A and marker B and this will be the test result.
- 15 Compare the test result against the compliance test limit.

NOTE

Some designs do not have tristate at V_{REF} (for example, 0.9V). This test is not guaranteed when this scenario happens, as there is no significant point of where the driver has been turned-off.

Test References

See Table 11 - Electrical Characteristics and AC Timing, in the *JEDEC Standard JESD79E*.

tHZ(DQS), DQS High Impedance Time From CK/CK# - Test Method of Implementation

The purpose of this test is to verify that the time when the DQS starts driving (from tristate to high state OR low state stage), to the clock signal crossing, is within the conformance limits as specified in the JEDEC Standard JESD79E.

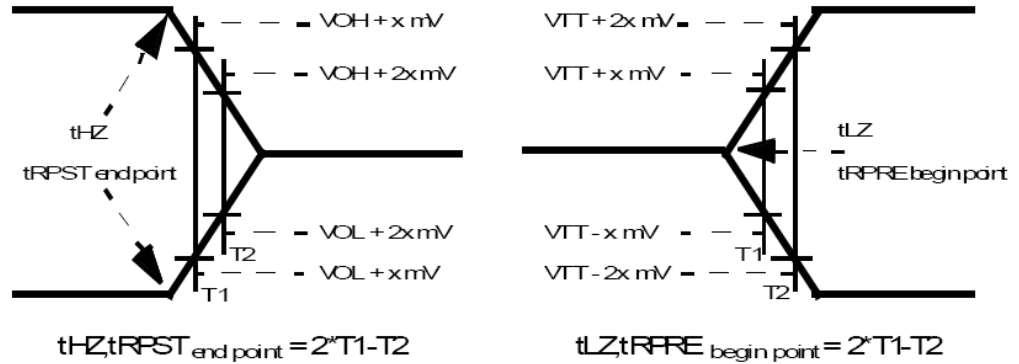

Figure 31 Method for Calculating Transitions and Endpoints

Signals of Interest

Based on the test definition (Read cycle only):

- Data Strobe Signal (DQS as Pin Under Test Signal)
- Clock Signal (CK as Reference Signal)

Signals required to perform the test on the oscilloscope:

- Data Strobe Signal (DQS as Pin Under Test Signal)
- Data Signal (DQ as Supporting Signal)
- Clock Signal (CK as Reference Signal)

Optional signal required to separate the signals for the different Ranks:

- Chip Select Signal (\overline{CS} as additional signal, which requires an additional channel)

Test Definition Notes from the Specification

Table 34 Electrical Characteristics and AC Timing

AC Characteristics Parameter	Symbol	DDR 333		DDR 266		DDR 200		Units	Notes
		Min	Max	Min	Max	Min	Max		
DQ & DQS high-impedance time from $\overline{CK/CK\#}$	tHZ		+0.7		+0.7		+0.7	ns	15

AC Characteristics Parameter	Symbol	DDR 400A (2.5-3-3)		DDR 400B (3-3-3)		DDR 400C (3-4-4)		Units	Notes
		Min	Max	Min	Max	Min	Max		
DQ & DQS high-impedance time from $\overline{CK/CK\#}$	tHZ		+0.7		+0.7		+0.7	ns	15

NOTE 15: tHZ and tLZ transitions occurs in the same access time as valid data transitions. These parameters are referenced to a specific voltage level which specifies when the device output is no longer driving (tHZ), or begin driving (tLZ). Figure 31 shows a method to calculate the point when device is no longer driving (tHZ), or begins driving (tLZ) by measuring the signal at two different voltages. The actual voltage measurement points are not critical as long as the calculation is consistent.

PASS Condition

The measured time interval from the point where the DQS starts to transit from tristate to the moment it starts to drive at high/low state, to the clock signal crossing point should be within the specification limit.

Measurement Algorithm

- 1 Obtain the parameters and settings from the Configuration page.
- 2 Pre-condition the scope settings. Verify the actual DUT speed against the user speed selection at the Setup page.
- 3 Perform signal checking on all the signals in-use in the measurement to ensure that it can be triggered during the test. This includes Vp-p, Vmin, Vmax and Vmid of each signal.
- 4 Perform signal skew checking on the DQ-DQS to ensure that it can be triggered during the Read/Write separation later.
- 5 Chip Select (CS) option is only applicable if the user has selected “Yes” for the Verify Selected Rank Only option in the Configuration page. It uses the CS-DQS for signal separation. Else, by default, the DQS-DQ is used for signal separation.
- 6 Use the InfiniiScan feature with the Setup time and Hold time to find and capture the Read cycle.
- 7 If you have selected the $\overline{\text{CS}}$ option, skip the next step and go to step 9.
- 8 Search for the DQS preamble towards the right from the point where the Read cycle was previously captured. The For loops, TEdge and Delta Time are used to search the preamble.
- 9 Once the preamble is located, call the “BinaryEdgeNormal” function, using Clock as the reference to define the Histogram Window for the DQS signal.
- 10 The Histogram Window is required to cover the DQS signal from the high/low state to the moment it starts to turn off the driver into tristate.
- 11 Setup the threshold value and measurement point for the DQS signal based on the histogram result.
- 12 Once all the points are obtained, proceed with the trigonometry calculation to find the point where the DQS starts to transit from high/low to the time when it turned off its driver into tristate.
- 13 Assign marker A for the clock signal crossing point while marker B for the data signal start to drive.
- 14 Measure delta of marker A and marker B and this will be the test result.
- 15 Compare the test result against the compliance test limit.

Test References

See Table 11 - Electrical Characteristics and AC Timing, in the *JEDEC Standard JESD79E*.

tLZ(DQS), DQS Low-Impedance Time from CK/CK# - Test Method of Implementation

The purpose of this test is to verify that the time when the DQS starts driving (from tristate to high/low state) to the clock signal crossing, is within the conformance limit as specified in the *JEDEC Standard JESD79E*.

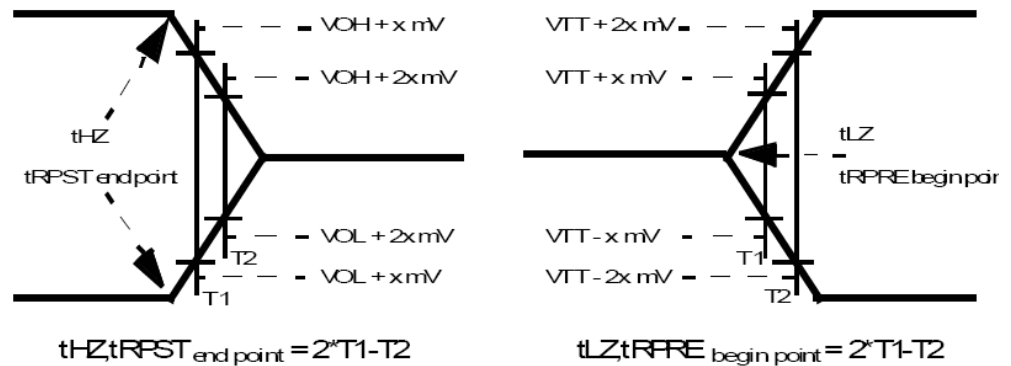

Figure 32 Method for Calculating Transitions and Endpoints

Signals of Interest

Based on the test definition (Read cycle only):

- Data Strobe Signal (DQS as Pin Under Test Signal)
- Clock Signal (CK as Reference Signal)

Signals required to perform the test on the oscilloscope:

- Data Strobe Signal (DQS as Pin Under Test Signal)
- Data Signal (DQ as Supporting Signal)
- Clock Signal (CK as Reference Signal)

Optional signal required to separate the signals for the different Ranks:

- Chip Select Signal (\overline{CS} as additional signal, which requires an additional channel)

Test Definition Notes from the Specification

Table 35 Electrical Characteristics and AC Timing

AC Characteristics Parameter	Symbol	DDR 333		DDR 266		DDR 200		Units	Notes
		Min	Max	Min	Max	Min	Max		
DQ & DQS high-impedance time from CK/CK#	tHZ		+0.7		+0.7		+0.7	ns	15

AC Characteristics Parameter	Symbol	DDR 400A (2.5-3-3)		DDR 400B (3-3-3)		DDR 400C (3-4-4)		Units	Notes
		Min	Max	Min	Max	Min	Max		
DQ & DQS high-impedance time from CK/CK#	tHZ		+0.7		+0.7		+0.7	ns	15

NOTE 15: tHZ and tLZ transitions occurs in the same access time as valid data transitions. These parameters are referenced to a specific voltage level which specifies when the device output is no longer driving (tHZ), or begin driving (tLZ). [Figure 32](#) shows a method to calculate the point when device is no longer driving (tHZ), or begins driving (tLZ) by measuring the signal at two different voltages. The actual voltage measurement points are not critical as long as the calculation is consistent.

PASS Condition

The measured time interval from the point where the DQS starts to transit from tristate to the moment when it starts to drive high/low (high impedance state to high/low state) to the clock signal crossing point, should be within the specification limit.

Measurement Algorithm

- 1 Obtain the parameters and settings from the Configuration page.
- 2 Pre-condition the scope settings. Verify the actual DUT speed against the user speed selection at the Setup page.
- 3 Perform signal checking on all the signals in-use in the measurement to ensure that it can be triggered during the test. This includes Vp-p, Vmin, Vmax and Vmid of each signal.
- 4 Perform signal skew checking on the DQ-DQS to ensure that it can be triggered during the Read/Write separation later.
- 5 Chip Select (CS) option is only applicable if the user has selected “Yes” for the Verify Selected Rank Only option in the Configuration page. It uses the CS-DQS for signal separation. Else, by default, the DQS-DQ is used for signal separation.
- 6 Use the InfiniiScan feature with the Setup time and Hold time to find and capture the Read cycle.
- 7 If you have selected the $\overline{\text{CS}}$ option, skip the next step and go to step 9.
- 8 Search for the DQS preamble towards the left from the point where the Read cycle was previously captured. The For loops, TEdge and Delta Time are used to search the preamble.
- 9 Once the preamble is located, call the “BinaryEdgeNormal” function, using the Clock as the reference to define the Histogram Window for the DQS signal.
- 10 The Histogram Window is required to cover the DQS signal from tristate to the moment it starts to drive the signal high/low.
- 11 Setup the threshold value and measurement point for the DQS signal based on the histogram result.
- 12 Once all the points are obtained, proceed with the trigonometry calculation to find the point where the DQS starts to transit from tristate to the time when it start to drive high/low.
- 13 Assign marker A for the clock signal crossing point while marker B for the data signal start to drive.
- 14 Measure delta of marker A and marker B and this will be the test result.
- 15 Compare the test result against the compliance test limit.

Test References

See Table 11 - Electrical Characteristics and AC Timing, in the *JEDEC Standard JESD79E*.

tLZ(DQ), DQ Low-Impedance Time from CK/CK# - Test Method of Implementation

The purpose of this test is to verify that the time when the DQ starts driving (from high impedance state to high/low state), to the clock signal crossing, is within the conformance limit as specified in the JEDEC Standard JESD79E.

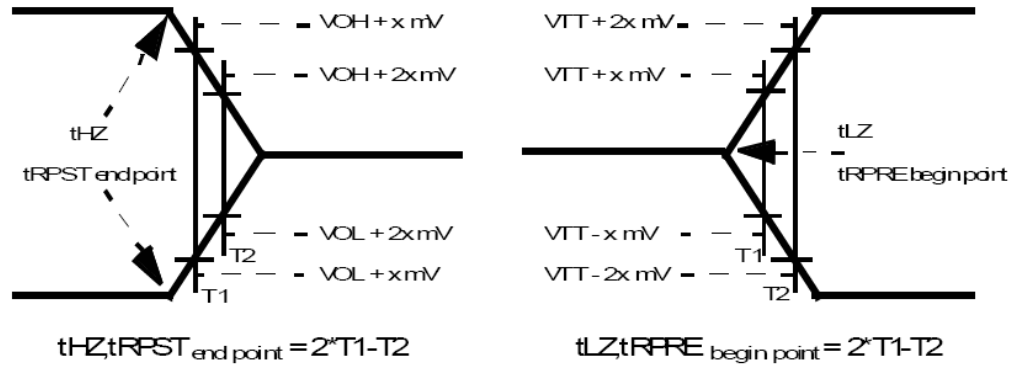

Figure 33 Method for Calculating Transitions and Endpoints

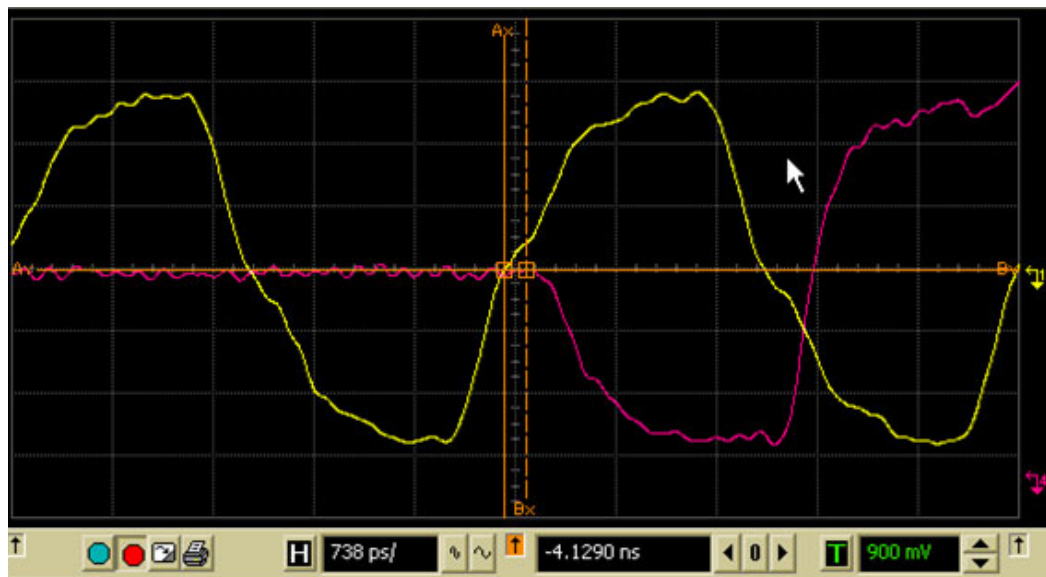

Figure 34 tLZ(DQ) in Infiniium oscilloscope.

Signals of Interest

Based on the test definition (Read cycle only):

- Data Signal (DQ as Pin Under Test Signal)
- Clock Signal (CK as Reference Signal)

Signals required to perform the test on the oscilloscope:

- Data Signal (DQ as Pin Under Test Signal)
- Data Strobe Signal (DQS as Supporting Signal)
- Clock Signal (CK as Reference Signal)

Optional signal required to separate the signals for the different Ranks:

- Chip Select Signal (\overline{CS} as additional signal, which requires an additional channel)

Test Definition Notes from the Specification

Table 36 Electrical Characteristics and AC Timing

AC Characteristics Parameter	Symbol	DDR 333		DDR 266		DDR 200		Units	Notes
		Min	Max	Min	Max	Min	Max		
DQ & DQS low-impedance time from $\overline{CK/CK}$	tLZ	-0.70	+0.70	-0.75	+0.75	-0.8	+0.8	ns	15

AC Characteristics Parameter	Symbol	DDR 400A (2.5-3-3)		DDR 400B (3-3-3)		DDR 400C (3-4-4)		Units	Notes
		Min	Max	Min	Max	Min	Max		
DQ & DQS low-impedance time from $\overline{CK/CK}$	tLZ	-0.70	+0.70	-0.70	+0.70	-0.70	+0.70	ns	15

NOTE 15: tHZ and tLZ transitions occurs in the same access time as valid data transitions. These parameters are referenced to a specific voltage level which specifies when the device output is no longer driving (tHZ), or begin driving (tLZ). [Figure 33](#) shows a method to calculate the point when device is no longer driving (tHZ), or begins driving (tLZ) by measuring the signal at two different voltages. The actual voltage measurement points are not critical as long as the calculation is consistent.

PASS Condition

The measured time interval from the point where the DQ starts to transit from high impedance to the moment when it starts to drive high/low (high impedance state to high/low state), to the clock signal crossing point, should be within the specification limit.

Measurement Algorithm

- 1 Obtain the parameters and settings from the Configuration page.
- 2 Pre-condition the scope settings. Verify the actual DUT speed against the user speed selection at the Setup page.
- 3 Perform signal checking on all the signals in-use in the measurement to ensure that it can be triggered during the test. This includes Vp-p, Vmin, Vmax and Vmid of each signal.
- 4 Perform signal skew checking on the DQ-DQS to ensure that it can be triggered during the Read/Write separation later.
- 5 Chip Select (\overline{CS}) option is only applicable if the user has selected “Yes” for the Verify Selected Rank Only option in the Configuration page. It uses the \overline{CS} -DQS for signal separation. Else, by default, the DQS-DQ is used for signal separation.
- 6 Use the InfiniiScan feature with the Setup time and Hold time to find and capture the Read cycle.
- 7 If you have selected the \overline{CS} option, skip the next step and go to step 9.
- 8 Search for the DQS preamble towards the left from the point where the Read cycle was previously captured. The For loops, TEdge and Delta Time are used to search the preamble.
- 9 Once the preamble is located, call the “BinaryEdgeNormal” function, using the Clock as the reference to define the Histogram Window for the DQ signal.

- 10 The Histogram Window is required to cover the DQ signal from the tristate to the moment it starts to drive high/low state.
- 11 Setup the threshold value and measurement point for the DQ signal based on the histogram result.
- 12 Once all the points are obtained, proceed with the trigonometry calculation to find the point where the DQ starts to transit from tristate to the time when it start to drive the signal high/low.
- 13 Assign marker A for the clock signal crossing point while marker B for the data signal start to drive.
- 14 Measure delta of marker A and marker B and this will be the test result.
- 15 Compare the test result against the compliance test limit.

Test References

See Table 11 - Electrical Characteristics and AC Timing, in the *JEDEC Standard JESD79E*.

tDQSQ, DQS-DQ Skew for DQS and Associated DQ Signals - Test Method of Implementation

The purpose of this test is to verify that the time interval from the data strobe output (DQS rising and falling edge) access time to the associated data (DQ rising and falling) signal is within the conformance limit as specified in the *JEDEC Standard JESD79E*.

Signals of Interest

Based on the test definition (Read cycle only):

- Data Signal (DQ as Pin Under Test Signal)
- Data Strobe Signal (DQS as Supporting Signal)

Signals required to perform the test on the oscilloscope:

- Data Signal (DQ as Pin Under Test Signal)
- Data Strobe Signal (DQS as Supporting Signal)
- Clock Signal (CK as Reference Signal)

Optional signal required to separate the signals for the different Ranks:

- Chip Select Signal (\overline{CS} as additional signal, which requires an additional channel)

Test Definition Notes from the Specification

Table 37 Electrical Characteristics and AC Timing

AC Characteristics Parameter	Symbol	DDR 333		DDR 266		DDR 200		Units	Notes
		Min	Max	Min	Max	Min	Max		
DQS-DQ Skew (for DQS & associated DQ signals)	TSOP Pkg	tDQSQ	+0.45	+0.5	+0.6	ns	26		
	BGA Pkg	tDQSQ	+0.4	+0.5	+0.6	ns	26		

AC Characteristics Parameter	Symbol	DDR 400A (2.5-3-3)		DDR 400B (3-3-3)		DDR 400C (3-4-4)		Units	Notes
		Min	Max	Min	Max	Min	Max		
DQS-DQ Skew (for DQS & associated DQ signals)	TSOP Pkg	tDQSQ	+0.4	+0.4	+0.4	ns	26		
	BGA Pkg	tDQSQ	+0.4	+0.4	+0.4	ns	26		

NOTE 26: tDQSQ Consists of data pin skew and output pattern effects, and p=channel to n-channel variation of the output drivers for any given cycle.

PASS Condition

The measured time interval between the data strobe and the associated data signal should be within specification limit.

Measurement Algorithm

- 1 Obtain the parameters and settings from the Configuration page.
- 2 Pre-condition the scope settings. Verify the actual DUT speed against the user speed selection at the Setup page.
- 3 Perform signal checking on all the signals in-use in the measurement to ensure that it can be triggered during the test. This includes Vp-p, Vmin, Vmax and Vmid of each signal.

- 4 Perform signal skew checking on the DQ-DQS to ensure that it can be triggered during the Read/Write separation later.
- 5 Chip Select ($\overline{\text{CS}}$) option is only applicable if the user has selected “Yes” for the Verify Selected Rank Only option in the Configuration page. It uses the $\overline{\text{CS}}$ -DQS for signal separation. Else, by default, the DQS-DQ is used for signal separation.
- 6 Use the InfiniiScan feature with the Setup time and Hold time to find and capture the Read cycle.
- 7 If you have selected the $\overline{\text{CS}}$ option, skip the next step and go to step 9.
- 8 Search for the DQS preamble towards the left from the point where the Read Cycle was previously captured. The For loops, TEdge and Delta Time are used to search the preamble.
- 9 Once the preamble is located, call the “BinaryEdgeNormal” function to obtain the Edge number of the DQS and DQ signal. This Edge number will be used for the TEdge measurement, in order to locate the points of interest on specific signal.
- 10 After obtaining the Edge number for the respective signal, begin the tDQSQ measurement bit by bit in the Read data burst, beginning from the 1st bit of the Read cycle.
- 11 Begin at the 1st bit of the Read cycle, from the Read preamble. Continue the measurement until the last bit (for example, until a tristate happens, which indicates the end of a data burst for the respective Read cycle).
- 12 DQS-Clock timing measurement compares the rising edge (V_{ih_ac} OR V_{il_dc} against DQS crossing) OR the falling edge (V_{ih_ac} OR V_{il_dc} against DQS crossing).
- 13 Within the data burst, measure each bit, for instance the rising and falling edge of the DQS-Clock. Capture the worst case data each time a new value is measured.
- 14 Once all bits are validated, assign marker A for the clock signal while marker B for the data signal, for the worst case bit.
- 15 Measure delta of marker A and marker B and this will be the test result.
- 16 Compare the test result against the compliance test limit.

Test References

See Table 11 - Electrical Characteristics and AC Timing, in the *JEDEC Standard JESD79E*.

tQH, DQ/DQS Output Hold Time From DQS – Test Method of Implementation

The purpose of this test is to verify that the time interval from the data output hold time (DQ rising and falling edge) from the DQS (rising and falling edge) is within the conformance limit as specified in the *JEDEC Standard JESD79E*.

Signals of Interest

Based on the test definition (Read cycle only):

- Data Signal (DQ as Pin Under Test Signal)
- Data Strobe Signal (DQS as Supporting Signal)

Signals required to perform the test on the oscilloscope:

- Data Signal (DQ as Pin Under Test Signal)
- Data Strobe Signal (DQS as Supporting Signal)
- Clock Signal (CK as Reference Signal)

Optional signal required to separate the signals for the different Ranks:

- Chip Select Signal (\overline{CS} as additional signal, which requires an additional channel)

Test Definition Notes from the Specification

Table 38 Electrical Characteristics and AC Timing

AC Characteristics Parameter	Symbol	DDR 333		DDR 266		DDR 200		Units	Notes
		Min	Max	Min	Max	Min	Max		
DQ & DQS output hold time from DQS	tQH	tQP-tQHS		tQP-tQHS		tQP-tQHS		ns	25

AC Characteristics Parameter	Symbol	DDR 400A (2.5-3-3)		DDR 400B (3-3-3)		DDR 400C (3-4-4)		Units	Notes
		Min	Max	Min	Max	Min	Max		
DQ & DQS output hold time from DQS	tQH	tQP-tQHS		tQP-tQHS		tQP-tQHS		ns	25

NOTE 25: $t_{QH} = t_{HP} - t_{QHS}$, where:

t_{HP} = minimum half clock period for any given cycle and is defined by clock high or clock low (t_{CH} , t_{CL}). t_{QHS} accounts for:

- 1) The pulse duration distortion of on-chip clock circuits; and
- 2) The worst case push-out of DQS on one transition followed by the worst case pull-in of DQ on the next transition, both of which are, separately, due to data pin skew and output pattern effects, and p-channel to n-channel variation of the output drivers.

PASS Condition

The measured time interval between the data output hold time and the associated data strobe signal should be within specification limit.

Measurement Algorithm

- 1 Obtain the parameters and settings from the Configuration page.
- 2 Pre-condition the scope settings. Verify the actual DUT speed against the user speed selection at the Setup page.

- 3 Perform signal checking on all the signals in-use in the measurement to ensure that it can be triggered during the test. This includes V_{p-p} , V_{min} , V_{max} and V_{mid} of each signal.
- 4 Perform signal skew checking on the DQ-DQS to ensure that it can be triggered during the Read/Write separation later.
- 5 Chip Select (CS) option is only applicable if the user has selected “Yes” for the Verify Selected Rank Only option in the Configuration page. It uses the CS-DQS for signal separation. Else, by default, the DQS-DQ is used for signal separation.
- 6 Use the InfiniiScan feature with the Setup time and Hold time to find and capture the Read cycle.
- 7 If you have selected the CS option, skip the next step and go to step 9.
- 8 Search for the DQS preamble towards the left from the point where the Read cycle was previously captured. The For loops, TEdge and Delta Time are used to search the preamble.
- 9 Once the preamble is located, call the “BinaryEdgeNormal” function to obtain the Edge number of the DQS and DQ signal. This Edge number will be used for the TEdge measurement, in order to locate the points of interest on specific signal.
- 10 After obtaining the Edge number for the respective signal, begin the tQH measurement bit by bit in Read Data Burst, beginning from the 1st bit of the Read cycle.
- 11 Begin at the 1st bit of the Read cycle, from the Read preamble. Continue the measurement until the last bit (for instance, until a tristate happens, which indicates the end of a data burst for the respective Read cycle).
- 12 DQS-DQ timing measurement compares the rising edge (DQS crossing against V_{il_dc} of the DQ signal, for instance, end of valid DQ hold time) OR the falling edge (DQS crossing against V_{ih_dc} of the DQ signal, for instance, end of valid DQ hold time).
- 13 Within the data burst, measure each bit, for instance the rising and falling edge of the DQS-DQ. Capture the worst case data each time a new value is measured.
- 14 Once all bits are validated, assign marker A for the lock signal while marker B for the data signal, for the Worst Case bit.
- 15 Measure delta of marker A and marker B and this will be the test result.
- 16 Compare the test result against the compliance test limit.

Test References

See Table 11 - Electrical Characteristics and AC Timing, in the *JEDEC Standard JESD79E*.

tDQSS, DQS Latching Transition to Associated Clock Edge - Test Method of Implementation

The purpose of this test is to verify that the time interval from the data strobe output (DQS falling edge) access time to the associated clock (crossing point) is within the conformance limit as specified in the *JEDEC Standard JESD79E*.

Signals of Interest

Based on the test definition (Write cycle only):

- Data Strobe Signal (DQS as Pin Under Test Signal)
- Clock Signal (CK as Reference Signal)

Signals required to perform the test on the oscilloscope:

- Data Strobe Signal (DQS as Pin Under Test Signal)
- Data Signal (DQ as Supporting Signal)
- Clock Signal (CK as Reference Signal)

Optional signal required to separate the signals for the different Ranks:

- Chip Select Signal (\overline{CS} as additional signal, which requires additional channel)

Test Definition Notes from the Specification

Table 39 Electrical Characteristics and AC Timing

AC Characteristics Parameter	Symbol	DDR 333		DDR 266		DDR 200		Units	Notes
		Min	Max	Min	Max	Min	Max		
Write command to first DQS latching transition	tDQSS	0.75	1.25	0.75	1.25	0.75	1.25	tCK	

AC Characteristics Parameter	Symbol	DDR 400A (2.5-3-3)		DDR 400B (3-3-3)		DDR 400C (3-4-4)		Units	Notes
		Min	Max	Min	Max	Min	Max		
Write command to first DQS latching transition	tDQSS	0.72	1.25	0.72	1.25	0.72	1.25	tCK	

PASS Condition

The measured time interval between the rising edge of the data strobe access output and the clock crossing should be within specification limit.

Measurement Algorithm

- 1 Obtain the parameters and settings from the Configuration page.
- 2 Pre-condition the scope settings. Verify the actual DUT speed against the user speed selection at the Setup page.
- 3 Perform signal checking on all the signals in-use in the measurement to ensure that it can be triggered during the test. This includes V_{p-p} , V_{min} , V_{max} and V_{mid} of each signal.
- 4 Perform signal skew checking on the DQ-DQS to ensure that it can be triggered during the Read/Write separation later.
- 5 Chip Select (\overline{CS}) option is only applicable if the user has selected "Yes" for the Verify Selected Rank Only option in the Configuration page. It uses the CS-DQS for signal separation. Else, by default, the DQS-DQ is used for signal separation.
- 6 Use the InfiniiScan feature with the Setup time and Hold time to find and capture the Read cycle.

- 7 If you have selected the $\overline{\text{CS}}$ option, skip the next step and go to step 9.
- 8 Search for the DQS preamble towards the left from the point where the Read cycle was previously captured. The For loops, TEdge and Delta Time are used to search the preamble.
- 9 Once the preamble is located, call the “BinaryEdgeNormal” function to obtain the Edge number of clock rising edge and strobe rising edge. This Edge number will be used for TEdge measurement, in order to locate the points of interest on specific signal.
- 10 After obtaining the Edge number for the respective signal, begin the tDQSS measurement bit by bit in the Write data burst, beginning from the 1st bit of the Write cycle. Begin at the 1st bit of the read cycle, from the Write preamble.
- 11 Continue the measurement until the last bit (for instance, until a tristate happens, which indicates the end of a data burst for the respective Write cycle).
- 12 DQS-Clock timing measurement compares the rising edge (DQS crossing against clock crossing) OR the falling edge (DQS crossing against Vih_dc of the DQ signal, for instance, end of valid DQ hold time).
- 13 Within the data burst, measure each bit, for instance the rising edge of the DQS-Clock. Capture the worst case data each time a new value is measured.
- 14 Once all bits are validated, assign marker A for the clock signal while marker B for the data signal, for the worst case bit.
- 15 Measure delta of marker A and marker B and this will be the test result.
- 16 Compare the test result against the compliance test limit.

Test References

See Table 11 - Electrical Characteristics and AC Timing, in the *JEDEC Standard JESD79E*.

tDQSH, DQS Input High Pulse Width – Test Method of Implementation

The purpose of this test is to verify that the width of the high level of the data strobe signal is within the conformance limit as specified in the *JEDEC Standard JESD79E*.

Signals of Interest

Based on the test definition (Read cycle only):

- Data Strobe Signal (DQS as Pin Under Test Signal)

Signals required to perform the test on the oscilloscope:

- Data Strobe Signal (DQS as Pin Under Test Signal)
- Data Signal (DQ as Supporting Signal)
- Clock Signal (CK as Reference Signal)

Optional signal required to separate the signals for the different Ranks:

- Chip Select Signal (\overline{CS} as additional signal, which requires additional channel)

Test Definition Notes from the Specification

Table 40 Electrical Characteristics and AC Timing

AC Characteristics Parameter	Symbol	DDR 333		DDR 266		DDR 200		Units	Notes
		Min	Max	Min	Max	Min	Max		
DQS input high pulse width	tDQSH	0.35		0.35		0.35		tCK	

AC Characteristics Parameter	Symbol	DDR 400A (2.5-3-3)		DDR 400B (3-3-3)		DDR 400C (3-4-4)		Units	Notes
		Min	Max	Min	Max	Min	Max		
DQS input high pulse width	tDQSH	0.35		0.35		0.35		tCK	

PASS Condition

The measured pwidth of the data strobe signal should be within specification limit.

Measurement Algorithm

- 1 Obtain the parameters and settings from the Configuration page.
- 2 Pre-condition the scope settings. Verify the actual DUT speed against the user speed selection at the Setup page.
- 3 Chip Select (\overline{CS}) option is only applicable if the user has selected “Yes” for the Verify Selected Rank Only option in the Configuration page. It uses the \overline{CS} -DQS for signal separation. Else, by default, the DQS-DQ is used for signal separation.
- 4 Use the InfiniiScan feature with the Setup time and Hold time to find and capture the Read cycle.
- 5 If you have selected the \overline{CS} option, skip the next step and go to step 7.
- 6 Search for the DQS preamble towards the left from the point where the Read cycle was previously captured. The for loops, TEdge and Delta Time are used to search the preamble.
- 7 Once the preamble is located, call the “BinaryEdgeNormal” function to obtain the Edge number. This Edge number will be used to locate the point of interest on the specific signal.

- 8 After obtaining the Edge number for the respective signal, begin the tDQSH measurement by using the Pwidth function to find any rising edge of the data strobe signal and measure the pwidth for every single bit in the captured data burst.
- 9 Assign marker A for the rising edge of the clock signal while marker B for the falling edge of the clock signal.
- 10 Measure delta of marker A and marker B and this will be the test result.
- 11 Compare the test result against the compliance test limit.

Test References

See Table 11 - Electrical Characteristics and AC Timing, in the *JEDEC Standard JESD79E*.

tDQSL, DQS Input Low Pulse Width – Test Method of Implementation

The purpose of this test is to verify that the width of the low level of the clock signal is within the conformance limit as specified in the *JEDEC Standard JESD79E*.

Signals of Interest

Based on the test definition (Read cycle only):

- Data Strobe Signal (DQS as Pin Under Test Signal)

Signals required to perform the test on the oscilloscope:

- Data Strobe Signal (DQS as Pin Under Test Signal)
- Data Signal (DQ as Supporting Signal)
- Clock Signal (CK as Reference Signal)

Optional signal required to separate the signals for the different Ranks:

- Chip Select Signal (\overline{CS} as additional signal, which requires an additional channel)

Test Definition Notes from the Specification

Table 41 Electrical Characteristics and AC Timing

AC Characteristics Parameter	Symbol	DDR 333		DDR 266		DDR 200		Units	Notes
		Min	Max	Min	Max	Min	Max		
DQS input low pulse width	tDQSL	0.35		0.35		0.35		tCK	

AC Characteristics Parameter	Symbol	DDR 400A (2.5-3-3)		DDR 400B (3-3-3)		DDR 400C (3-4-4)		Units	Notes
		Min	Max	Min	Max	Min	Max		
DQS input low pulse width	tDQSL	0.35		0.35		0.35		tCK	

PASS Condition

The measured nwidth of the clock signal should be within specification limit.

Measurement Algorithm

- 1 Obtain the parameters and settings from the Configuration page.
- 2 Pre-condition the scope settings. Verify the actual DUT speed against the user speed selection at the Setup page.
- 3 Perform signal checking on all the signals in-use in the measurement to ensure that it can be triggered during the test. This includes V_{p-p} , V_{min} , V_{max} and V_{mid} of each signal.
- 4 Perform signal skew checking on the DQ-DQS to ensure that it can be triggered during the Read/Write separation later.
- 5 Chip Select (\overline{CS}) option is only applicable if the user has selected “Yes” for the Verify Selected Rank Only option in the Configuration page. It uses the \overline{CS} -DQS for signal separation. Else, by default, the DQS-DQ is used for signal separation.
- 6 Use the InfiniiScan feature with Setup time and Hold time to find and capture the Read cycle.
- 7 If you have selected the \overline{CS} option, skip the next step and go to step 9.

- 8 Search for the DQS preamble towards the left from the point where the Read cycle was previously captured. The for loops, TEdge and Delta Time are used to search the preamble.
- 9 Once the preamble is located, call the "BinaryEdgeNormal" function to obtain the Edge number. This Edge number will be used to locate the point of interest on the specific signal.
- 10 After obtaining the Edge number for the respective signal, begin the tDQSL measurement by using the Nwidth function to find any rising edge of the data strobe signal and measure the nwidth for every single bit in the captured data burst.
- 11 Assign marker A for the rising edge of the clock signal while marker B for the falling edge of the clock signal.
- 12 Measure delta of marker A and marker B and this will be the test result.
- 13 Compare the test result against the compliance test limit.

Test References

See Table 11 - Electrical Characteristics and AC Timing, in the *JEDEC Standard JESD79E*.

tDSS, DQS Falling Edge to CK Setup Time - Test Method of Implementation

The purpose of this test is to verify that the time interval from the falling edge of the data strobe (DQS falling edge) output access time to the clock setup time, is within the conformance limit as specified in the *JEDEC Standard JESD79E*.

Signals of Interest

Based on the test definition (Write cycle only):

- Data Strobe Signal (DQS as Pin Under Test Signal)
- Clock Signal (CK as Reference Signal)

Signals required to perform the test on the oscilloscope:

- Data Strobe Signal (DQS as Pin Under Test Signal)
- Data Signal (DQ as Supporting Signal)
- Clock Signal (CK as Reference Signal)

Optional signal required to separate the signals for the different Ranks:

- Chip Select Signal (\overline{CS} as additional signal, which requires an additional channel)

Test Definition Notes from the Specification

Table 42 Electrical Characteristics and AC Timing

AC Characteristics Parameter	Symbol	DDR 333		DDR 266		DDR 200		Units	Notes
		Min	Max	Min	Max	Min	Max		
DQS falling edge to CK setup time	tDSS	0.2		0.2		0.2		tCK	

AC Characteristics Parameter	Symbol	DDR 400A (2.5-3-3)		DDR 400B (3-3-3)		DDR 400C (3-4-4)		Units	Notes
		Min	Max	Min	Max	Min	Max		
DQS falling edge to CK setup time	tDSS	0.2		0.2		0.2		tCK	

PASS Condition

The measured time interval between the falling edge of the data strobe access output to the associated clock setup time should be within the specification limit.

Measurement Algorithm

- 1 Obtain the parameters and settings from the Configuration page.
- 2 Pre-condition the scope settings. Verify the actual DUT speed against the user speed selection at the Setup page.
- 3 Perform signal checking on all the signals in-use in the measurement to ensure that it can be triggered during the test. This includes V_{p-p} , V_{min} , V_{max} and V_{mid} of each signal.
- 4 Perform signal skew checking on the DQ-DQS to ensure that it can be triggered during the Read/Write separation later.
- 5 Chip Select (\overline{CS}) option is only applicable if the user has selected "Yes" for the Verify Selected Rank Only option in the Configuration page. It uses the CS-DQS for signal separation. Else, by default, the DQS-DQ is used for signal separation.
- 6 Use the InfiniiScan feature with the Setup time and Hold time to find and capture the Read cycle.

- 7 If you have selected the $\overline{\text{CS}}$ option, skip the next step and go to step 9.
- 8 Search for the DQS preamble towards the left from the point where the Write cycle was previously captured. The For loops, TEdge and Delta Time are used to search the preamble.
- 9 Once the preamble is located, call the "BinaryEdgeNormal" function to obtain the Edge number. This Edge number will be used to locate the point of interest on the specific signal.
- 10 After obtaining the Edge number for the respective signal, begin the tDSS measurement bit by bit in Write data burst.
- 11 Begin at the 1st bit of the Write cycle, from the Write preamble. Continue the measurement until the last bit (for example, until a tristate happens, which indicates the end of a data burst for the respective Write cycle).
- 12 DQS-Clock timing measurement compares the rising edge (DQS falling against clock crossing).
- 13 DQ-Clock timing measurement compares the falling edge of the DQS to the clock setup time. The worst case data will be captured each time new value is measured.
- 14 Once all bits are validated, assign marker A for the clock signal while marker B for the data signal, for the worst case bit.
- 15 Measure delta of marker A and marker B and this will be the test result.
- 16 Compare the test result against the compliance test limit.

Test References

See Table 11 - Electrical Characteristics and AC Timing, in the *JEDEC Standard JESD79E*.

tDSH, DQS Falling Edge Hold Time from CK – Test Method of Implementation

The purpose of this test is to verify that the time interval from the falling edge of the data strobe output access time to the hold time of the clock, must be within the conformance limit as specified in the *JEDEC Standard JESD79E*.

Signals of Interest

Based on the test definition (Write cycle only):

- Data Strobe Signal (DQS as Pin Under Test Signal)
- Clock Signal (CK as Reference Signal)

Signals required to perform the test on the oscilloscope:

- Data Strobe Signal (DQS as Pin Under Test Signal)
- Data Signal (DQ as Supporting Signal)
- Clock Signal (CK as Reference Signal)

Optional signal required to separate the signals for the different Ranks:

- Chip Select Signal (\overline{CS} as additional signal, which requires an additional channel)

Test Definition Notes from the Specification

Table 43 Electrical Characteristics and AC Timing

AC Characteristics Parameter	Symbol	DDR 333		DDR 266		DDR 200		Units	Notes
		Min	Max	Min	Max	Min	Max		
DQS falling edge hold time from CK	tDSH	0.2		0.2		0.2		tCK	

AC Characteristics Parameter	Symbol	DDR 400A (2.5-3-3)		DDR 400B (3-3-3)		DDR 400C (3-4-4)		Units	Notes
		Min	Max	Min	Max	Min	Max		
DQS falling edge hold time from CK	tDSH	0.2		0.2		0.2		tCK	

PASS Condition

The measured time interval between the falling edge of the data strobe hold time from the associated clock crossing edge should be within the specification limit.

Measurement Algorithm

- 1 Obtain the parameters and settings from the Configuration page.
- 2 Pre-condition the scope settings. Verify the actual DUT speed against the user speed selection at the Setup page.
- 3 Perform signal checking on all the signals in-use in the measurement to ensure that it can be triggered during the test. This includes V_{p-p} , V_{min} , V_{max} and V_{mid} of each signal.
- 4 Perform signal skew checking on the DQ-DQS to ensure that it can be triggered during the Read/Write separation later.
- 5 Chip Select (\overline{CS}) option is only applicable if the user has selected “Yes” for the Verify Selected Rank Only option in the Configuration page. It uses the CS-DQS for signal separation. Else, by default, the DQS-DQ is used for signal separation.
- 6 Use the InfiniiScan feature with the Setup time and Hold time to find and capture the Read cycle.

- 7 If you have selected the $\overline{\text{CS}}$ option, skip the next step and go to step 9.
- 8 Search for the DQS preamble towards the left from the point where the Write cycle was previously captured. The For loops, TEdge and Delta Time are used to search the preamble.
- 9 Once the preamble is located, call the “BinaryEdgeNormal” function to obtain the Edge number. This Edge number will be used to locate the point of interest on the specific signal.
- 10 After obtaining the Edge number for the respective signal, begin the tDSH measurement bit by bit in Write data burst.
- 11 Begin at the 1st bit of the Write cycle, from the Write preamble. Continue the measurement until the last bit (for example, until a tristate happens, which indicates the end of a data burst for the respective Write cycle).
- 12 DQS-Clock timing measurement compares the falling edge of the DQS crossing hold time from the respective clock crossing edge.
- 13 Within the data burst, each bit, for instance, the falling edge of DQS-Clock will be measured. The worst case data will be captured each time a new value is measured.
- 14 Once all the bits are validated, assign marker A for the clock signal while marker B for the data signal, for the worst case bit.
- 15 Measure delta of marker A and marker B and this will be the test result.
- 16 Compare the test result against the compliance test limit.

Test References

See Table 11 - Electrical Characteristics and AC Timing, in the *JEDEC Standard JESD79E*.

tWPST, Write Postamble - Test Method of Implementation

The purpose of this test is to verify that the time when the DQS is no longer driving (from high/low state to high impedance) from the last DQS signal crossing (last bit of the write data burst) for the Write cycle, is within the conformance limit as specified in the *JEDEC Standard JESD79E*.

Signals of Interest

Based on the test definition (Write cycle only):

- Data Strobe Signal (DQS as Pin Under Test Signal)

Signals required to perform the test on the oscilloscope:

- Data Strobe Signal (DQS as Pin Under Test Signal)
- Data Signal (DQ as Supporting Signal)
- Clock Signal (CK as Reference Signal)

Optional signal required to separate the signals for the different Ranks:

- Chip Select Signal (CS as additional signal, which requires an additional channel)

Test Definition Notes from the Specification

Table 44 Electrical Characteristics and AC Timing

AC Characteristics Parameter	Symbol	DDR 333		DDR 266		DDR 200		Units	Notes
		Min	Max	Min	Max	Min	Max		
Write postamble	tWPST	0.40	0.60	0.40	0.60	0.40	0.60	tCK	16

AC Characteristics Parameter	Symbol	DDR 400A (2.5-3-3)		DDR 400B (3-3-3)		DDR 400C (3-4-4)		Units	Notes
		Min	Max	Min	Max	Min	Max		
Write postamble	tWPST	0.40	0.60	0.40	0.60	0.40	0.60	tCK	16

NOTE 16: The maximum limit for this parameter is not device limit. The device will operate with greater value for this parameter, but system performance (bus turnaround) will degrade accordingly.

PASS Condition

The measured time interval between the last DQS signal crossing point and the point where the DQS starts to transit from high/low state to high impedance should be within the specification limit.

Measurement Algorithm

- 1 Obtain the parameters and settings from the Configuration page.
- 2 Pre-condition the scope settings. Verify the actual DUT speed against the user speed selection at the Setup page.
- 3 Perform signal checking on all the signals in-use in the measurement to ensure that it can be triggered during the test. This includes V_{p-p} , V_{min} , V_{max} and V_{mid} of each signal.
- 4 Perform signal skew checking on the DQ-DQS to ensure that it can be triggered during the Read/Write separation later.

- 5 Chip Select ($\overline{\text{CS}}$) option is only applicable if the user has selected “Yes” for the Verify Selected Rank Only option in the Configuration page. It uses the CS-DQS for signal separation. Else, by default, the DQS-DQ is used for signal separation.
- 6 Use the InfiniiScan feature with the Setup time and Hold time to find and capture the Read cycle.
- 7 If you have selected the $\overline{\text{CS}}$ option, skip the next step and go to step 9.
- 8 Search for the DQS postamble towards the right from the point where the Write cycle was previously captured. The For loops, TEdge and Delta Time are used to search the postamble.
- 9 Once the postamble is located, call the “BinarySearchNormal” function to locate the last DQS crossing point or reference point.
- 10 Define the histogram window in order to obtain the Min and Max voltage for the DQS postamble signal and it will be used for the threshold setup for the trigonometry calculation later.
- 11 Once all points are obtained, proceed with the trigonometry calculation to find the point where the DQS starts to transit from high/low to the time when it starts to turn off the driver low (for instance, end of burst or postamble).
- 12 Assign marker A for the DQS signal crossing point while marker B for the data strobe signal start to turn off driver.
- 13 Measure delta of marker A and marker B and this will be the test result.
- 14 Compare the test result against the compliance test limit.

Test References

See Table 11 - Electrical Characteristics and AC Timing, in the *JEDEC Standard JESD79E*.

tWPRE, Write Preamble - Test Method of Implementation

The purpose of this test is to verify that the time when the DQS starts to drive low (preamble behavior) to the first DQS signal crossing for the Write cycle, is within the conformance limit as specified in the JEDEC Standard JESD79E.

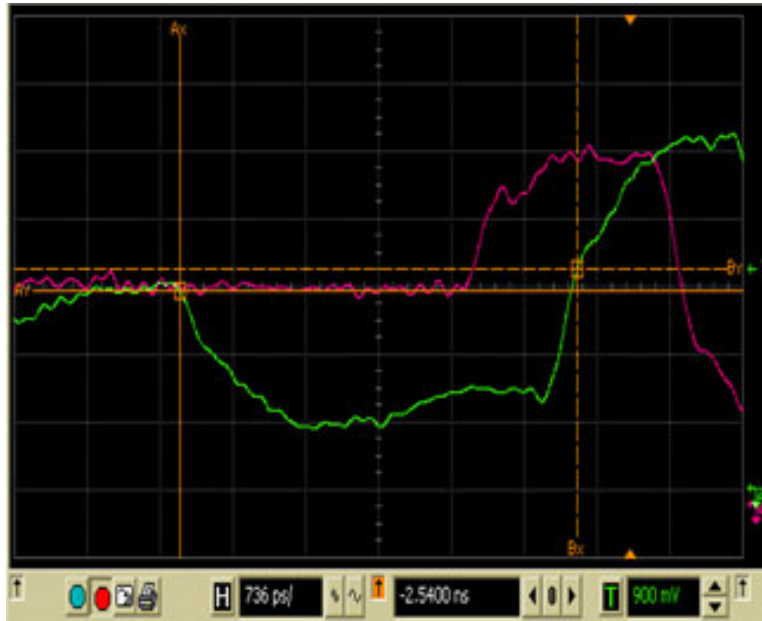

Figure 35 tWPRE in Infiniium oscilloscope

Signals of Interest

Based on the test definition (Write cycle only):

- Data Strobe Signal (DQS as Pin Under Test Signal)

Signals required to perform the test on the oscilloscope:

- Data Strobe Signal (DQS as Pin Under Test Signal)
- Data Signal (DQ as Supporting Signal)
- Clock Signal (CK as Reference Signal)

Optional signal required to separate the signals for the different Ranks:

- Chip Select Signal (CS as additional signal, which requires an additional channel)

Test Definition Notes from the Specification

Table 45 Electrical Characteristics and AC Timing

AC Characteristics Parameter	Symbol	DDR 333		DDR 266		DDR 200		Units
		Min	Max	Min	Max	Min	Max	
Write preamble	tWPRE	0.25		0.25		0.25		tCK

AC Characteristics Parameter	Symbol	DDR 400A (2.5-3-3)		DDR 400B (3-3-3)		DDR 400C (3-4-4)		Units
		Min	Max	Min	Max	Min	Max	
Write preamble	tWPRE	max (0.25*tCK, 1.5 ns)		max (0.25*tCK, 1.5 ns)		max (0.25*tCK, 1.5 ns)		ns

PASS Condition

The measured time interval of the point where the DQS starts to transit from tristate (high impedance state to low state) to the DQS signal crossing point for the Write cycle, should be within the specification limit.

Measurement Algorithm

- 1 Obtain the parameters and settings from the Configuration page.
- 2 Pre-condition the scope settings. Verify the actual DUT speed against the user speed selection at the Setup page.
- 3 Perform signal checking on all the signals in-use in the measurement to ensure that it can be triggered during the test. This includes Vp-p, Vmin, Vmax and Vmid of each signal.
- 4 Perform signal skew checking on the DQ-DQS to ensure that it can be triggered during the Read/Write separation later.
- 5 Chip Select (\overline{CS}) option is only applicable if the user has selected "Yes" for the Verify Selected Rank Only option in the Configuration page. It uses the CS-DQS for signal separation. Else, by default, the DQS-DQ is used for signal separation.
- 6 Use the InfiniiScan feature with the Setup time and Hold time to find and capture the Read cycle.
- 7 If you have selected the \overline{CS} option, skip the next step and go to step 9.
- 8 Search for the DQS preamble towards the left from the point where the Write cycle was previously captured. The For loops, TEdge and Delta Time are used to search the preamble.
- 9 Once the preamble is located, call the "BinarySearchNormal" function to locate the first DQS crossing point or the reference point.
- 10 Define the histogram window in order to obtain the Min and Max voltage for the DQS preamble signal and it will be used for the threshold setup for the trigonometry calculation later.
- 11 Once all the points are obtained, proceed with the trigonometry calculation to find the point where the DQS starts to transit from tristate to the time when it starts to drive low (for instance, beginning of preamble).
- 12 Assign marker A for the DQS signal crossing point while marker B for the data strobe signal start to drive low.
- 13 Measure delta of marker A and marker B and this will be the test result.
- 14 Compare the test result against the compliance test limit.

Test References

See Table 11 - Electrical Characteristics and AC Timing, in the *JEDEC Standard JESD79E*.

tRPRE, Read Preamble – Test Method of Implementation

The purpose of this test is to verify that the time when the DQS start driving low (*preamble behavior) to the first DQS signal crossing for the Read cycle must be within the conformance limit as specified in the *JEDEC Standard JESD79E*.

Signals of Interest

Based on the test definition (Read cycle only):

- Data Strobe Signal (DQS as Pin Under Test Signal)

Signals required to perform the test on the oscilloscope:

- Data Strobe Signal (DQS as Pin Under Test Signal)
- Data Signal (DQ as Supporting Signal)
- Clock Signal (CK as Reference Signal)

Optional signal required to separate the signals for the different Ranks:

- Chip Select Signal (CS as additional signal, which requires additional channel)

Test Definition Notes from the Specification

Table 46 Electrical Characteristics and AC Timing

AC Characteristics Parameter	Symbol		DDR 333		DDR 266		DDR 200		Units	Notes
			Min	Max	Min	Max	Min	Max		
Read preamble	CL = 2.5	tRPRE	0.9	1.1	0.9	1.1	0.9	1.1	tCK	28, 33
	CL = 2.0		0.9	1.1	0.9	1.1	0.9	1.1	tCK	28, 33
	CL = 2.5		NA	NA	NA	NA	-	1.1	tCK	28, 33

AC Characteristics Parameter	Symbol		DDR 400A (2.5-3-3)		DDR 400B (3-3-3)		DDR 400C (3-4-4)		Units	Notes
			Min	Max	Min	Max	Min	Max		
Read preamble	CL = 3	tRPRE	0.9	1.1	0.9	1.1	0.9	1.1	tCK	28, 33
	CL = 2.5		0.9	1.1	0.9	1.1	0.9	1.1	tCK	28, 33
	CL = 2.0		0.9	1.1	0.9	1.1	0.9	1.1	tCK	28, 33
	CL = 1.5		NA	NA	NA	NA	NA	NA		

NOTE 28: Optional CAS Latency, 1.5, is only defined for DDR 200 speed grade

NOTE 33: tRPST end; point and tRPRE begin point are not referenced to a specific voltage level but specify when the device output is no longer driving (tRPST), or begins driving (tRPRE).

PASS Condition

The measured time interval of the point where the DQS starts to transit from tristate (high impedance state to low state) to the DQS signal crossing point for the Read cycle should be within the specification limit.

Measurement Algorithm

- 1 Obtain the parameters and settings from the Configuration page.
- 2 Pre-condition the scope settings. Verify the actual DUT speed against the user speed selection at the Setup page.
- 3 Perform signal checking on all the signals in-use in the measurement to ensure that it can be triggered during the test. This includes Vp-p, Vmin, Vmax and Vmid of each signal.
- 4 Perform signal skew checking on the DQ-DQS to ensure that it can be triggered during the Read/Write separation later.
- 5 Chip Select (\overline{CS}) option is only applicable if the user has selected “Yes” for the Verify Selected Rank Only option in the Configuration page. It uses the CS-DQS for signal separation. Else, by default, the DQS-DQ is used for signal separation.
- 6 Use the InfiniiScan feature with the Setup time and Hold time to find and capture the Read cycle.
- 7 If you have selected the \overline{CS} option, skip the next step and go to step 9.
- 8 Search for the DQS preamble towards the left from the point where the Read cycle was previously captured. The For loops, TEdge and Delta Time are used to search the preamble.
- 9 Once the preamble is located, call the “BinarySearchNormal” function to locate the first DQS crossing point or the reference point.
- 10 Define the histogram window in order to obtain the Min and Max voltage for the DQS preamble signal and it will be used for the threshold setup for the trigonometry calculation later.
- 11 Once all the points are obtained, proceed with the trigonometry calculation to find the point where the DQS starts to transit from tristate to the time when it start to drive low (for instance, beginning of preamble).
- 12 Assign marker A for the DQS signal crossing point while marker B for the data strobe signal start to drive low.
- 13 Measure delta of marker A and marker B and this will be the test result.
- 14 Compare the test result against the compliance test limit.

Test References

See Table 11 - Electrical Characteristics and AC Timing, in the *JEDEC Standard JESD79E*.

tRPST, Read Postamble - Test Method of Implementation

The purpose of this test is to verify that the time when the DQS is no longer driving (from high/low state to high-impedance) to the last DQS signal crossing (last bit of the data burst) for the Read cycle is within the conformance limit as specified in the *JEDEC Standard JESD79E*.

Signals of Interest

Based on the test definition (Read cycle only):

- Data Strobe Signal (DQS as Pin Under Test Signal)

Signals required to perform the test on the oscilloscope:

- Data Strobe Signal (DQS as Pin Under Test Signal)
- Data Signal (DQ as Supporting Signal)
- Clock Signal (CK as Reference Signal)

Optional signal required to separate the signals for the different Ranks:

Chip Select Signal (\overline{CS} as additional signal, which requires an additional channel)

Test Definition Notes from the Specification

Table 47 Electrical Characteristics and AC Timing

AC Characteristics Parameter	Symbol	DDR 333		DDR 266		DDR 200		Units	Notes
		Min	Max	Min	Max	Min	Max		
Read postamble	tRPST	0.4	0.6	0.4	0.6	0.4	0.6	tCK	33

AC Characteristics Parameter	Symbol	DDR 400A (2.5-3-3)		DDR 400B (3-3-3)		DDR 400C (3-4-4)		Units	Notes
		Min	Max	Min	Max	Min	Max		
Read postamble	tRPST	0.4	0.6	0.4	0.6	0.4	0.6	tCK	33

NOTE 33: tRPST end; point and tRPRE begin point are not referenced to a specific voltage level but specify when the device output is no longer driving (tRPST), or begins driving (tRPRE).

PASS Condition

The measured time interval between the last DQS signal crossing point to the point where the DQS starts to transit from high/low level to high impedance for the Read cycle should be within the specification limit.

Measurement Algorithm

- 1 Obtain the parameters and settings from the Configuration page.
- 2 Pre-condition the scope setting. Verify the actual DUT speed against the user speed selection at the Setup page.
- 3 Perform signal checking on all the signals in-use in the measurement to ensure that it can be triggered during the test. This includes Vp-p, Vmin, Vmax and Vmid of each signal.
- 4 Perform signal skew checking on the DQ-DQS to ensure that it can be triggered during the Read/Write separation later.

- 5 Chip Select (\overline{CS}) option is only applicable if the user has selected “Yes” for the Verify Selected Rank Only option in the Configuration page. It uses the CS-DQS for signal separation. Else, by default, the DQS-DQ is used for signal separation.
- 6 Use the InfiniiScan feature with the Setup time and Hold time to find and capture the Read cycle.
- 7 If you have selected the \overline{CS} option, skip the next step and go to step 9.
- 8 Search for the DQS postamble towards the right from the point where the Read cycle was previously captured. The For loops, TEdge and Delta Time are used to search the postamble.
- 9 Once the postamble is located, call the “BinarySearchNormal” function to locate the last DQS crossing point or reference point.
- 10 Define the histogram window in order to obtain the Min and Max voltage for the DQS postamble signal and it will be used for the threshold setup for the trigonometry calculation later.
- 11 Once all points are obtained, proceed with the trigonometry calculation to find the point where the DQS starts to transit from high/low to the time when it starts to turn off the driver low (for instance, end of burst, postamble).
- 12 Assign marker A for the DQS signal crossing point while marker B for the data strobe signal start to turn off the driver.
- 13 Measure delta of marker A and marker B and this will be the test result.
- 14 Compare the test result against the compliance test limit.

Test References

See Table 11 - Electrical Characteristics and AC Timing, in the *JEDEC Standard JESD79E*.

8 Clock Timing (CT) Tests

Probing for Clock Timing Tests / 118

tAC, DQ Output Access Time from CK/CK# - Test Method of Implementation / 121

tDQSCK, DQS Output Access Time from CK/CK# - Test Method of Implementation / 124

Average Clock Period - tCK(avg) - Test Method of Implementation / 128

Average High Pulse Width - tCH(avg) - Test Method of Implementation / 130

Average Low Pulse Width - tCL(avg) - Test Method of Implementation / 131

This section provides the Methods of Implementation (MOIs) for Clock Timing tests using an Keysight 54850A, 8000, 80000 or 90000A series Infiniium oscilloscope, recommended InfiniiMax 116xA or 113xA probe amplifiers, E2677A differential solder-in probe head and the DDR1 Compliance Test Application.

NOTE

Both XYZ# and \overline{XYZ} are referring to compliment. Thus, CK# is the same as \overline{CK} .

Probing for Clock Timing Tests

When performing the Clock Timing tests, the DDR1 Compliance Test Application will prompt you to make the proper connections. The connection for Clock Timing tests may look similar to the following diagram. Refer to the Connection tab in DDR1 Compliance Test Application for the exact number of probe connections. Typically, you need minimum three probe connections to run the tests.

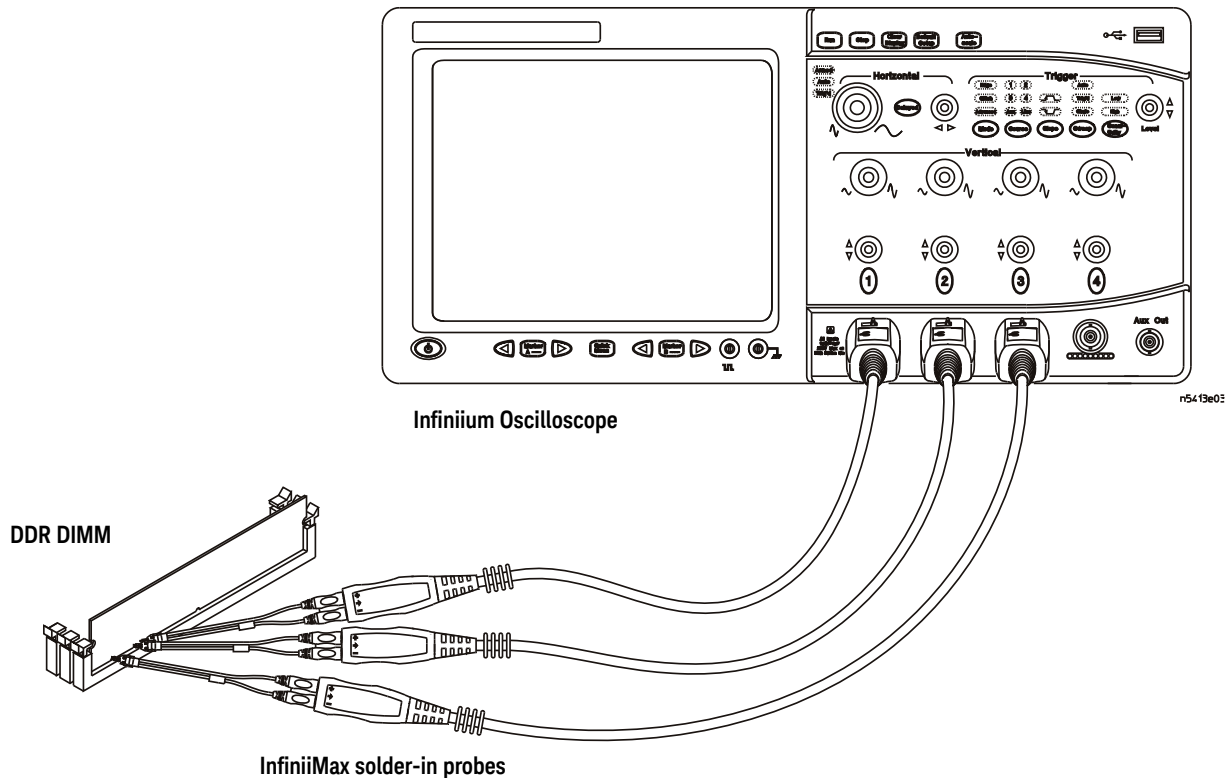

Figure 36 Probing for Clock Timing Tests with Three Probes

You can use any of the oscilloscope channels as Pin Under Test (PUT) source channel. You can identify the channels used for each signal in the Configuration tab of the DDR1 Compliance Test Application. (The channels shown in [Figure 36](#) are just examples).

For more information on the probe amplifiers and differential probe heads, see [Chapter 14](#), “InfiniiumMax Probing,” starting on page 185.

Test Procedure

- 1 Start the automated test application as described in [“Starting the DDR1 Compliance Test Application”](#) on page 27.
- 2 Ensure that the RAM reliability test software is running on the computer system where the DDR Device Under Test (DUT) is attached. This software will perform a test on all unused RAM on the system by producing a repetitive burst of read-write data signals to the DDR memory.

- 3 Connect the differential solder-in probe head to the PUTs on the DDR DIMM.
- 4 Connect the oscilloscope probes to any channels of the oscilloscope.
- 5 In the DDR1 Test Application, click the Set Up tab.
- 6 Select the Speed Grade options. For the Single-Ended Signals AC Input Parameters Tests, you can select any speed grade within the selection: DDR1-200, DDR1-266, DDR1-333, DDR1-400.
- 7 Type in or select the Device Identifier as well as User Description from the drop-down list. Enter your comments in the Comments text box.
- 8 Click the Select Tests tab and check the tests you want to run. Check the parent node or group to check all the available tests within the group.

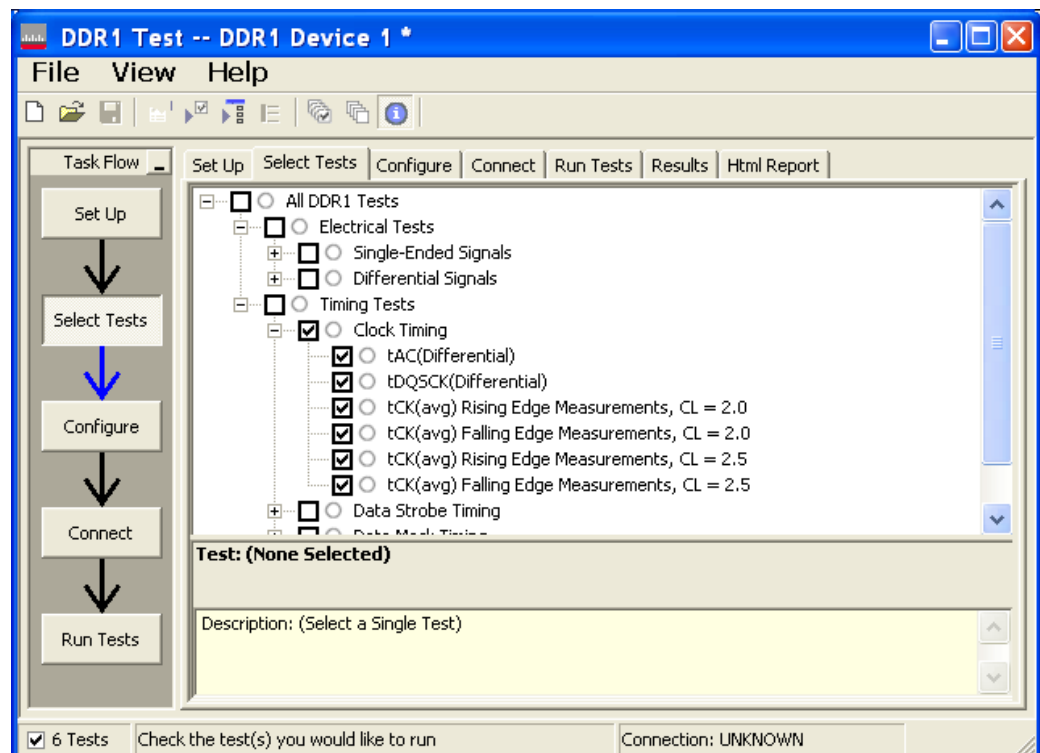

Figure 37 Selecting Clock Timing Tests

- 9 Follow the DDR1 Test Application's task flow to set up the configuration options (see [Table 48](#)), run the tests and view the tests results.

Table 48 Test Configuration Options

Configuration Option	Description
Stop on error	Enabling this error message will allow error message to prompt whenever criteria is not met. Disabling this option will allow the system to bypass all the error messages that could occur and continue to the next test. This option is suitable for long hours multiple trial.
Signal Threshold setting by percentage	This option allow user to define the Upper and Lower threshold of the signal by percentage.
VDD	Input supply voltage value.
VDDQ	Input supply voltage for data output.
Vref	Input reference voltage value.
Vih(DC)	Input voltage high value (direct current).
Vih(AC)	Input voltage high value (alternating current).
Vil(DC)	Input voltage low value (direct current).
Vil(AC)	Input voltage low value (alternating current).
Timing Tests	
Total Bit Display	Allows user to select the number of data bits to be displayed at the end of the test. Selecting more bits gives a better view of the entire burst of signals.
Verify Selected Rank Only?	If you choose Yes, you require an additional channel for the Chip Select (CS). Measurement will only be done on the selected rank based on the Chip Select signal connected to the oscilloscope.
Channel (1,2,3)	Signal connected to the specific channel.
Pin Under Test, PUT	Signal used for testing.

tAC, DQ Output Access Time from CK/CK# - Test Method of Implementation

The purpose of this test is to verify that the time interval from data output (DQ Rising and Falling Edge) access time to the nearest rising or falling edge of the clock must be within the conformance limit as specified in the JEDEC Standard JESD79E.

There is tAC(min) and tAC(max) as shown in Figure 39. From the specification, you can observe that the minimum value is at negative while the maximum is at positive.

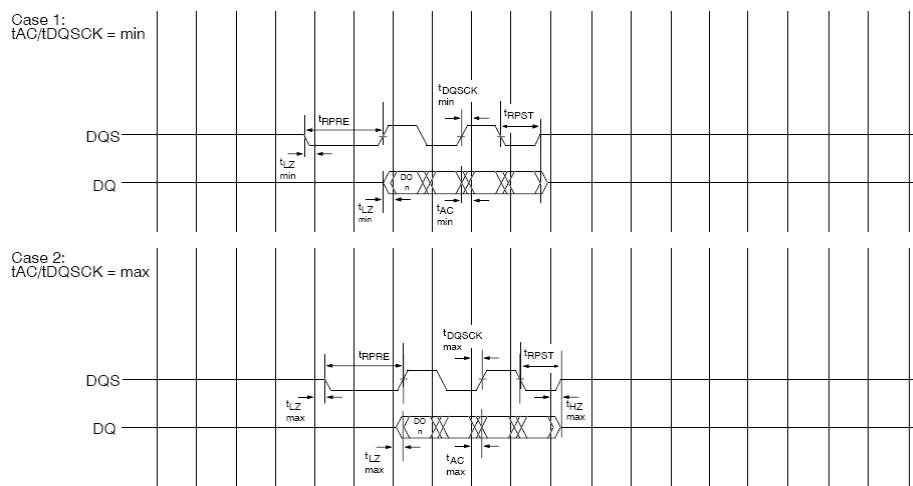

Figure 38 DQ Output Access Time from CK/CK#

Signals of Interest

Based on the test definition (Read cycle only):

- Data Signal (DQ as Pin Under Test Signal)
- Clock Signal (CK as Reference Signal)

Signals required to perform the test on the oscilloscope:

- Data Signal (DQ as Pin Under Test Signal)
- Data Strobe Signal (DQS as Supporting Signal)
- Clock Signal (CK as Reference Signal)

Optional signal required to separate the signals for the different Ranks:

- Chip Select Signal (CS as additional signal, which requires an additional channel)

Test Definition Notes from the Specification

Table 49 Electrical Characteristics and AC Timing

AC Characteristics - Parameter	Symbol	DDR 333		DDR 266		DDR 200		Units	Notes
		Min	Max	Min	Max	Min	Max		
DQ output access time from CK/CK#	tAC	-0.70	+0.70	-0.75	+0.75	-0.8	+0.8	ns	

AC Characteristics - Parameter	Symbol	DDR 400A (2.5-3-3)		DDR 400B (3-3-3)		DDR 400C (3-4-4)		Units	Notes
		Min	Max	Min	Max	Min	Max		
DQ output access time from CK/CK	tAC	-0.7	+0.7	-0.7	+0.7	-0.7	+0.7	ns	

Table 50 AC Timing Variations for DDR 333, DDR 266 & DDR 200 Devices

Parameter	DDR 333B		DDR 266A		DDR 266B		DDR 200		DDR 200B		Units
	Min	Max	Min	Max	Min	Max	Min	Max	Min	Max	
tAC	-0.7	0.7	-0.75	0.75	-0.75	0.75	-0.8	0.8	-0.8	0.8	ns

Pass Condition

The measured time interval between the data access output and the rising edge of the clock should be within the specification limits.

Measurement Algorithm

- 1 Obtain the parameters and settings from the Configuration page.
- 2 Pre-condition the scope setting. Verify the actual DUT speed against user speed selection at the Setup page.
- 3 Perform signal checking on all the signals in-use in the measurement to ensure that it can be triggered during the test. This includes Vp-p, Vmin, Vmax and Vmid of each signal.
- 4 Perform signal skew checking on the DQ-DQS to ensure that it can be triggered during the Read/Write separation later.
- 5 Chip Select (CS) option is only applicable if the user has selected "Yes" for the Verify Selected Rank Only option in the Configuration page. It uses the CS-DQS for signal separation. Else, by default, the DQS-DQ is used for signal separation. Search for the DQS pre-amble towards the left from the point where the Read Cycle was previously captured. The For loops, TEdge and DeltaTime are used to search the pre-amble.
- 6 Use the InfiniiScan feature with the Setup time and Hold time to find and capture the Read cycle.
- 7 If you have selected the CS option, skip the next step and go to step 9.
- 8 Search for the DQS preamble towards the left from the point where the Read cycle was previously captured. The For loops, TEdge and Delta Time are used to search the preamble.
- 9 Once the preamble is located, call the "BinaryEdgeNormal" function to obtain the Edge number. This Edge number will be used to locate the point of interest on the specific signal.
- 10 After obtaining the Edge# for the respective signal, begin the tAC measurement bit by bit in Read Data Burst. Begin at the 1st bit of the Read cycle, from the Read pre-amble.
- 11 Continue the measurement until last bit (for example, until a tristate happens, which indicates the end of a Data Burst for the respective Read Cycle).
- 12 DQ-Clock timing measurement compares the Rising Edge (Vih_ac OR ViL_dc against clock crossing) OR the Falling Edge (ViL_ac OR Vih_dc against clock crossing).
- 13 Within the data burst, measure each bit, for instance rising and falling edge of DQ-Clock. Capture the worst case data each time a new value is measured.
- 14 Once all bits are validated, assign marker A for clock signal while marker B for data signal, for the Worst Case bit.
- 15 Measure delta of marker A and marker B and this will be the test result.
- 16 Compare the test result against the compliance test limit.

Test References

See Table 11 - Electrical Characteristics and AC Timing and Table 12 - AC Timing Variations For DDR 333, DDR 266 and DDR 200 Devices, in the *JEDEC Standard JESD79E*.

tDQSCK, DQS Output Access Time from CK/CK #- Test Method of Implementation

The purpose of this test is to verify that the time interval from the data strobe output (DQS rising and falling edge) access time to the nearest rising or falling edge of the clock is within the conformance limit as specified in the *JEDEC Standard JESD79E*.

There is tDQSCK(min) and tDQSCK(max) as shown in **Figure 39**. From the specification, you can observe that the minimum value is at negative while the maximum is at positive.

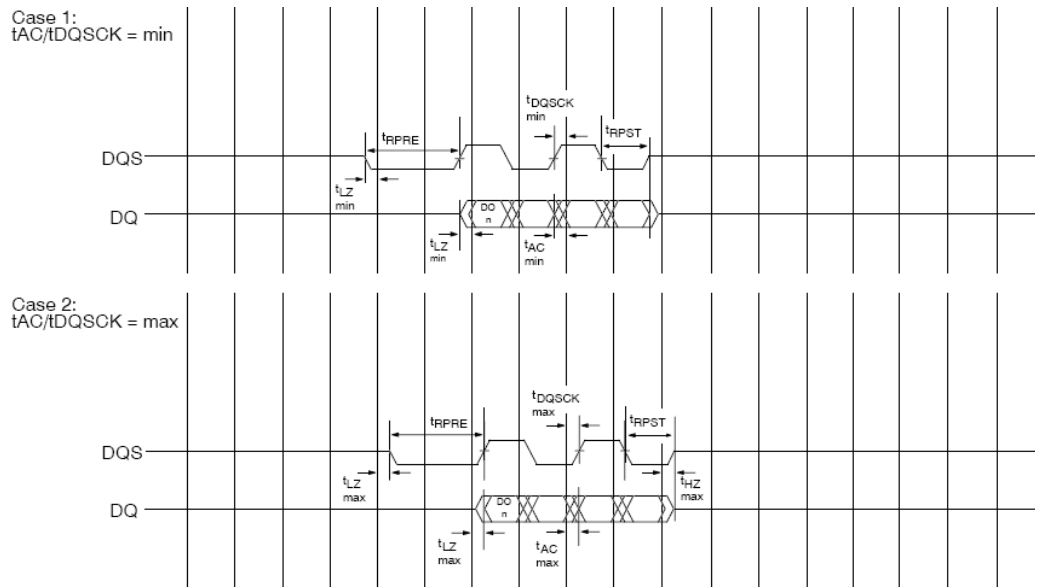

Figure 39 DQS Output Access Time from CK/CK#

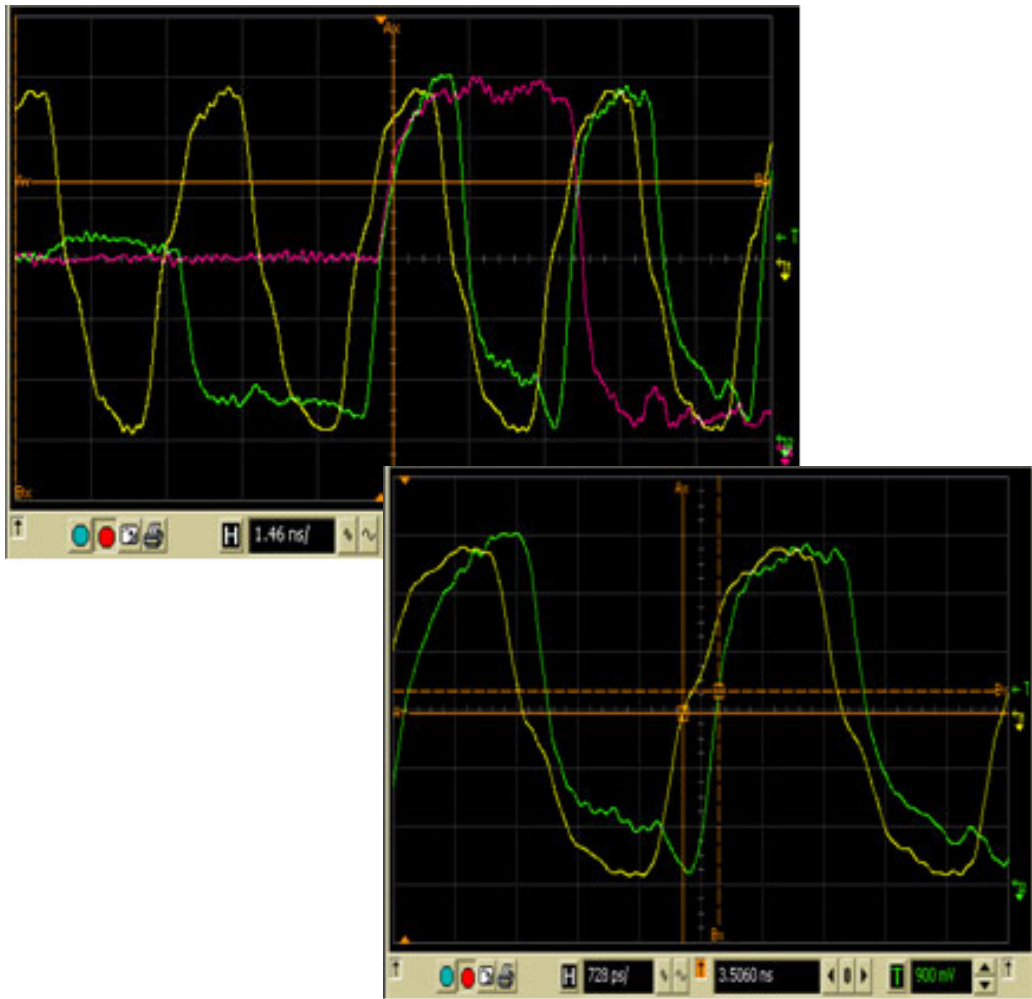

Figure 40 tDQSCK in Infiniium oscilloscope

Signals of Interest

Based on the test definition (Read cycle only):

- Data Strobe Signal (DQS as Pin Under Test Signal)
- Clock Signal (CK as Reference Signal)

Signals required to perform the test on the oscilloscope:

- Data Strobe Signal (DQS as Pin Under Test Signal)
- Data Signal (DQ as Supporting Signal)
- Clock Signal (CK as Reference Signal)

Optional signal required to separate the signals for the different Ranks:

- Chip Select Signal (\overline{CS} as additional signal, which requires an additional channel)

Test Definition Notes from the Specification

Table 51 Electrical Characteristics and AC Timing

AC Characteristics - Parameter	Symbol	DDR 333		DDR 266		DDR 200		Units	Notes
		Min	Max	Min	Max	Min	Max		
DQS output access time from $\overline{\text{CK}}/\text{CK}$	tDQSCK	-0.60	+0.60	-0.75	+0.75	-0.8	+0.8	ns	

AC Characteristics - Parameter	Symbol	DDR 400A (2.5-3-3)		DDR 400B (3-3-3)		DDR 400C (3-4-4)		Units	Notes
		Min	Max	Min	Max	Min	Max		
DQS output access time from $\overline{\text{CK}}/\text{CK}$	tDQSCK	-0.6	+0.6	-0.6	+0.6	-0.6	+0.6	ns	

Table 52 AC Timing Variations for DDR 333, DDR 266 & DDR 200 Devices

Parameter	DDR 333B		DDR 266A		DDR 266B		DDR 200		DDR 200B		Units
	Min	Max	Min	Max	Min	Max	Min	Max	Min	Max	
tDQSCK	-0.7	0.7	-0.75	0.75	-0.75	0.75	-0.8	0.8	-0.8	0.8	ns

PASS Condition

The measured time interval between the data strobe access output and the rising edge of the clock should be within the specification limit.

Measurement Algorithm

- 1 Obtain the parameters and settings from the Configuration page.
- 2 Pre-condition the scope setting. Verify the actual DUT speed against the user speed selection at the Setup page.
- 3 Perform signal checking on all the signals in-use in the measurement to ensure that it can be triggered during the test. This includes Vp-p, Vmin, Vmax and Vmid of each signal.
- 4 Perform signal skew checking on the DQ-DQS to ensure that it can be triggered during the Read/Write separation later.
- 5 Chip Select ($\overline{\text{CS}}$) option is only applicable if the user has selected "Yes" for the Verify Selected Rank Only option in the Configuration page. It uses the CS-DQS for signal separation. Else, by default, the DQS-DQ is used for signal separation.
- 6 Use the InfiniiScan feature with the Setup time and Hold time to find and capture the Read cycle.
- 7 If you have selected the $\overline{\text{CS}}$ option, skip the next step and go to step 9.
- 8 Search for the DQS preamble towards the left from the point where the Read cycle was previously captured. The For loops, TEdge and Delta Time are used to search the preamble.
- 9 Once the preamble is located, call the "BinaryEdgeNormal" function to obtain the Edge number. This Edge number will be used to locate the point of interest on the specific signal.
- 10 After obtaining the Edge number for the respective signal, begin the tDQSCK measurement bit by bit in the Read data burst. Begin at the 1st bit of the Read cycle, from the Read preamble.
- 11 Continue the measurement until last bit (for example, until a tristate happens, which indicates the end of a data burst for the respective Read cycle).
- 12 The DQS-Clock timing measurement compares the rising edge (DQS crossing against clock crossing) OR the falling edge (DQS crossing against clock crossing).
- 13 Within the data burst, measure each bit, for instance the rising and falling edge of the DQS-Clock. Capture the worst case data each time a new value is measured.

- 14 Once all bits are validated, assign marker A for the clock signal while marker B for the data signal, for the worst case bit.
- 15 Measure delta of marker A and marker B and this will be the test result.
- 16 Compare the test result against the compliance test limit.

Test References

See Table 11 - Electrical Characteristics and AC Timing and Table 12 - AC Timing Variations For DDR 333, DDR 266 and DDR 200 Devices, in the *JEDEC Standard JESD79E*.

Average Clock Period - tCK(avg) - Test Method of Implementation

This test is applicable to the Rising Edge Measurement as well as the Falling Edge Measurement. tCK(avg) is average clock period within 200 consecutive cycle window. The tCK(avg) Rising Edge Measurement measures the period from the rising edge of a cycle to the next rising edge within the waveform window. The tCK(avg) Falling Edge Measurements measures from the falling edge to the falling edge.

Signals of Interest

Based on the test definition:

- Clock Signal

Signals required to perform the test on the oscilloscope:

- Clock Signal - CK is required to perform pre-test to verify the DUT speed against user's speed grade selection

Test Definition Notes from the Specification

Table 53 Electrical Characteristics and AC Timing

AC Characteristics - Parameter	Symbol	DDR 333		DDR 266		DDR 200		Units	Notes
		Min	Max	Min	Max	Min	Max		
Clock cycle time CL = 2.5	tCK	6	12	7.5	12	10	12	ns	30
Clock cycle time CL = 2	tCK	7.5	12	7.5	12	10	12	ns	30

AC Characteristics - Parameter	Symbol	DDR 400A (2.5-3-3)		DDR 400B (3-3-3)		DDR 400C (3-4-4)		Units	Notes
Clock cycle time CL = 3	tCK	5	7.5	5	7.5	5	7.5	ns	30
Clock cycle time CL = 2.5	tCK	5	12	6	12	6	12	ns	30
Clock cycle time CL = 2	tCK	7.5	12	7.5	12	10	12	ns	30

Table 54 AC Timing Variations for DDR 333, DDR 266 & DDR 200 Devices

	DDR 333B		DDR 266A		DDR 266B		DDR 200		DDR 200B		Units
tCK CL = 2.5	6	12	7.5	12	7.5	12	10	12	10	12	ns
tCK CL = 2.0	7.5	12	7.5	12	10	12	10	12	10	12	ns

NOTE 30: The only time that the clock frequency is allowed to change is during self-refresh mode.

PASS Condition

The tCK(avg) measurement value should be within the conformance limits as specified in the *JEDEC Standard JESD79E*.

Measurement Algorithm

Example input test signal: Frequency: 1 KHz, Number of cycles acquired: 202.

- 1 This measurement measures a sliding “window” of 200 cycles.
- 2 Calculate the average period value for periods 1-200, 2-201 and 3-202.
- 3 Check the results for the smallest and largest values (worst case values).
- 4 Compare the test results against the compliance test limits.

Test References

See Table 11 - Electrical Characteristics and AC Timing and Table 12 - AC Timing Variations for DDR 333, DDR 266 and DDR 200 Devices, in the *JEDEC Standard JESD79E*.

Average High Pulse Width - tCH(avg) - Test Method of Implementation

The purpose of this test is to measure the average duty cycle of all the positive pulse widths within a window of 200 consecutive cycles.

Signals of Interest

Based on the test definition:

- Clock Signal

Signals required to perform the test on the oscilloscope:

- Clock Signal - CK is required to perform pre-test to verify the DUT speed against user's speed grade selection

Test Definition Notes from the Specification.

Table 55 Electrical Characteristics and AC Timing

AC Characteristics Parameter	Symbol	DDR 333		DDR 266		DDR 200		Units	Notes
		Min	Max	Min	Max	Min	Max		
CK high-level width	tCH	0.45	0.55	0.45	0.55	0.45	0.55	tCK	

AC Characteristics Parameter	Symbol	DDR 400A (2.5-3-3)		DDR 400B (3-3-3)		DDR 400C (3-4-4)		Units	Notes
		Min	Max	Min	Max	Min	Max		
CK high-level width	tCH	0.45	0.55	0.45	0.55	0.45	0.55	tCK	

Pass Condition

The tCH measurement value should be within the conformance limits as specified in the *JEDEC Standard JESD79E*.

Measurement Algorithm

Example input test signal: Frequency: 1 KHz, Number of cycles acquired: 202.

- 1 Measure the sliding "window" of 200 cycles.
- 2 Measure the width of the high pulses (1-200, 2-201 and 3-202) and determine the average value for this window.
- 3 Check the total 3 results for the smallest and largest values (worst case values).
- 4 Compare the test results against the compliance test limits.

Test References

See Table 11 - Electrical Characteristics and AC Timing, in the *JEDEC Standard JESD79E*.

Average Low Pulse Width - tCL(avg) - Test Method of Implementation

The purpose of this test is to measure the average duty cycle of all the negative pulse widths within a window of 200 consecutive cycles.

Signals of Interest

Based on the test definition:

- Clock Signal

Signals required to perform the test on the oscilloscope:

- Clock Signal - CK is required to perform pre-test to verify the DUT speed against user's speed grade selection

Test Definition Notes from the Specification.

Table 56 Electrical Characteristics and AC Timing

AC Characteristics Parameter	Symbol	DDR 333		DDR 266		DDR 200		Units	Notes
		Min	Max	Min	Max	Min	Max		
CK low-level width	tCL	0.45	0.55	0.45	0.55	0.45	0.55	tCK	

AC Characteristics Parameter	Symbol	DDR 400A (2.5-3-3)		DDR 400B (3-3-3)		DDR 400C (3-4-4)		Units	Notes
		Min	Max	Min	Max	Min	Max		
CK low-level width	tCL	0.45	0.55	0.45	0.55	0.45	0.55	tCK	

Pass Condition

The tCL measurement value should be within the conformance limits as specified in the *JEDEC Standard JESD79E*.

Measurement Algorithm

Example input test signal: Frequency: 1 KHz, Number of cycles acquired: 202.

- 1 Measure the sliding "window" of 200 cycles.
- 2 Measure the width of the low pulses (1-200, 2-201 and 3-202) and determine the average value for this window.
- 3 Check the total 3 results for the smallest and largest values (worst case values).
- 4 Compare results against the compliance test limits.

Test References

See Table 11 - Electrical Characteristics and AC Timing, in the *JEDEC Standard JESD79E*.

9 Data Mask Timing (DMT) Tests

Probing for Data Mask Timing Tests / 134

tDS(base), DQ and DM Input Setup Time - Test Method of Implementation / 137

tDH(base), DQ and DM Input Hold Time - Test Method of Implementation / 139

This section provides the Methods of Implementation (MOIs) for Data Mask Timing tests using an Keysight 54850A, 8000, 80000 or 90000A series Infiniium oscilloscope, recommended InfiniiMax 116xA or 113xA probe amplifiers, E2677A differential solder-in probe head and the DDR1 Compliance Test Application.

NOTE

Both XYZ# and \overline{XYZ} are referring to compliment. Thus, CK# is the same as \overline{CK} .

Probing for Data Mask Timing Tests

When performing the Data Mask Timing tests, the DDR1 Compliance Test Application will prompt you to make the proper connections. The connection for Data Mask Timing tests may look similar to the following diagrams. Refer to the Connection tab in DDR1 Compliance Test Application for the exact number of probe connections. Typically, you need minimum three probe connections to run the tests.

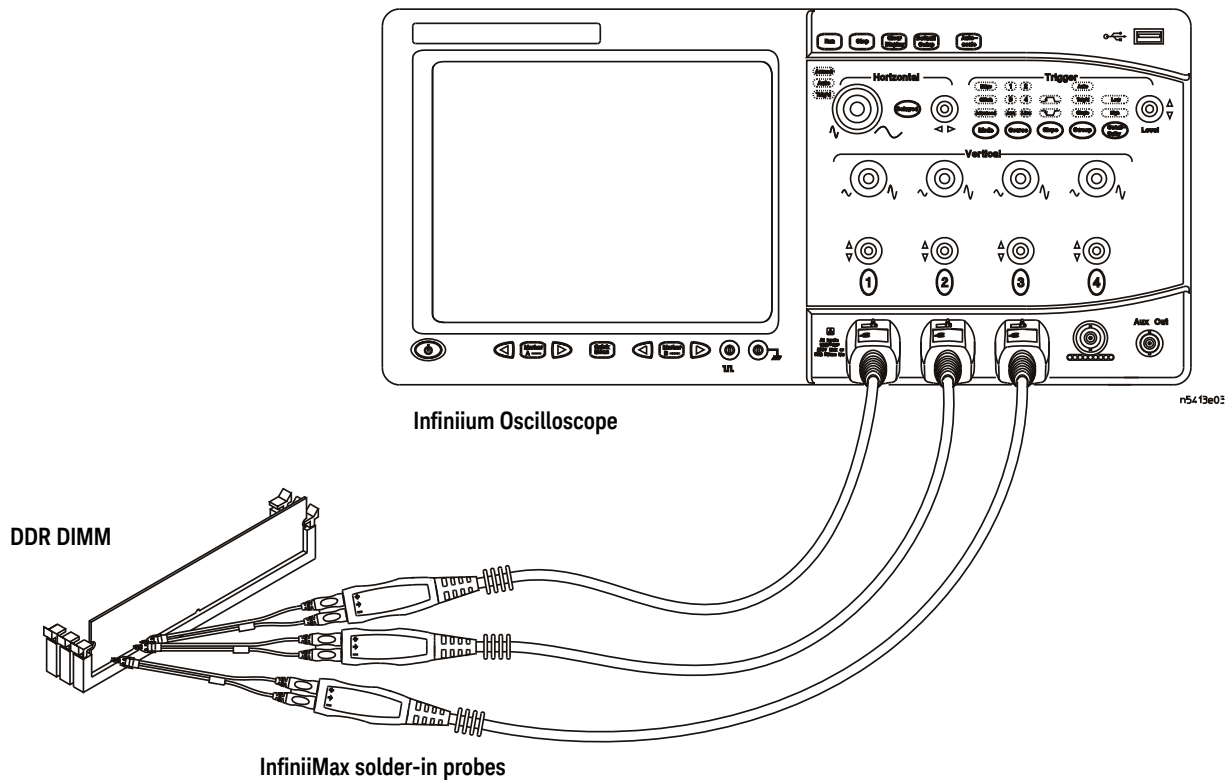

Figure 41 Probing for Data Mask Timing Tests with Three Probes

You can use any of the oscilloscope channels as Pin Under Test (PUT) source channel. You can identify the channels used for each signal in the Configuration tab of the DDR1 Compliance Test Application. (The channels shown in [Figure 41](#) are just examples).

For more information on the probe amplifiers and differential probe heads, see [Chapter 14](#), “InfiniMax Probing,” starting on page 185.

Test Procedure

- 1 Start the automated test application as described in [“Starting the DDR1 Compliance Test Application”](#) on page 27.
- 2 Ensure that the RAM reliability test software is running on the computer system where the DDR Device Under Test (DUT) is attached. This software will perform a test on all unused RAM on the system by producing a repetitive burst of read-write data signals to the DDR memory.

- 3 Connect the differential solder-in probe head to the PUTs on the DDR DIMM.
- 4 Connect the oscilloscope probes to any channels of the oscilloscope.
- 5 In the DDR1 Test Application, click the Set Up tab.
- 6 Select the Speed Grade options. For the Single-Ended Signals AC Input Parameters Tests, you can select any speed grade within the selection: DDR1-200, DDR1-266, DDR1-333, DDR1-400.
- 7 Type in or select the Device Identifier as well as User Description from the drop-down list. Enter your comments in the Comments text box.
- 8 Click the Select Tests tab and check the tests you want to run. Check the parent node or group to check all the available tests within the group.

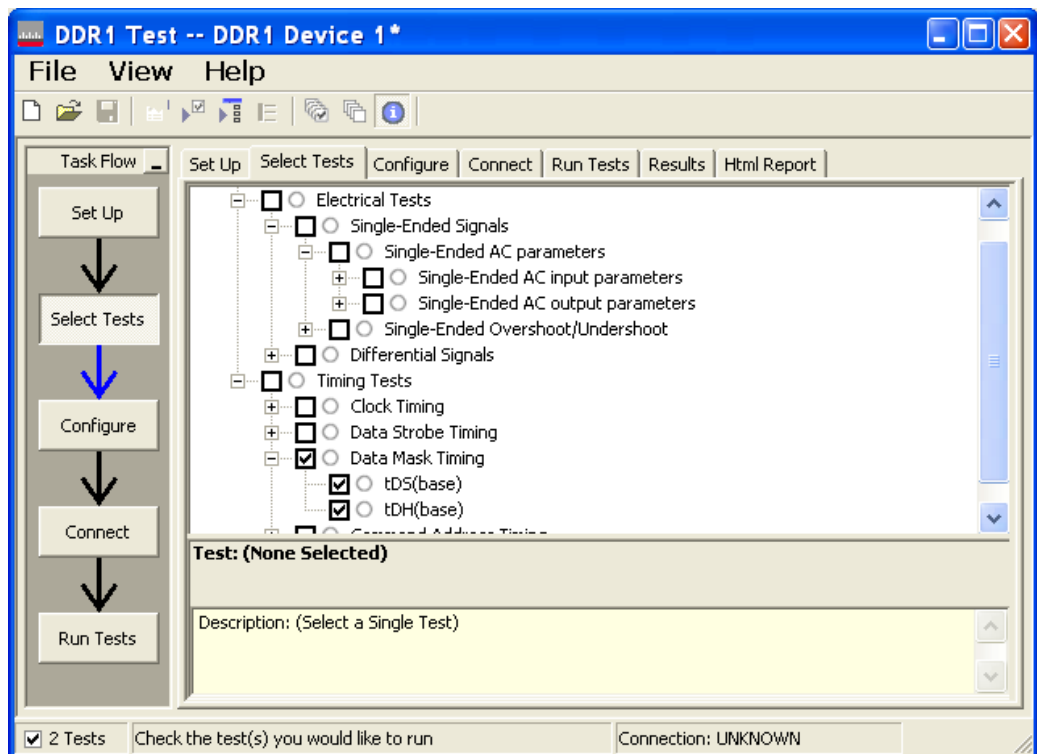

Figure 42 Selecting Data Mask Timing Tests

- 9 Follow the DDR1 Test Application's task flow to set up the configuration options (see [Table 57](#)), run the tests and view the tests results.

Table 57 Test Configuration Options

Configuration Option	Description
Stop on error	Enabling this error message will allow error message to prompt whenever criteria is not met. Disabling this option will allow the system to bypass all the error messages that could occur and continue to the next test. This option is suitable for long hours multiple trial.
Signal Threshold setting by percentage	This option allow user to define the Upper and Lower threshold of the signal by percentage.
VDD	Input supply voltage value.
VDDQ	Input supply voltage for data output.
Vref	Input reference voltage value.
Vih(DC)	Input voltage high value (direct current).
Vih(AC)	Input voltage high value (alternating current).
Vil(DC)	Input voltage low value (direct current).
Vil(AC)	Input voltage low value (alternating current).
Timing Tests	
Total Bit Display	Allows user to select the number of data bits to be displayed at the end of the test. Selecting more bits gives a better view of the entire burst of signals.
Verify Selected Rank Only?	If you choose Yes, you require an additional channel for the Chip Select (CS). Measurement will only be done on the selected rank based on the Chip Select signal connected to the oscilloscope.
Channel (1,2,3)	Signal connected to the specific channel.
Pin Under Test, PUT	Signal used for testing.

tDS(base), DQ and DM Input Setup Time - Test Method of Implementation

The purpose of this test is to verify that the time interval from the data or data mask (DQ/DM rising/falling Edge) setup time to the associated DQS crossing edge is within the conformance limits as specified in the *JEDEC Standard JESD79E*.

Signals of Interest

Based on the test definition (Write cycle only):

- Data Signal (DQ as Pin Under Test Signal)

Signals required to perform the test on the oscilloscope:

- Data Signal (DQ as Pin Under Test Signal)
- Data Strobe Signal (DQS as Supporting Signal)
 - Use differential connection (DQS+ and DQS-)
- Clock Signal (CK as Reference Signal)

Optional signal required to separate the signals for the different Ranks:

- Chip Select Signal (\overline{CS} as additional signal, which requires additional channel)

Test Definition Notes from the Specification

Table 58 Electrical Characteristics and AC Timing

AC Characteristics Parameter	Symbol	DDR 333		DDR 266		DDR 200		Units	Notes
		Min	Max	Min	Max	Min	Max		
DQ & DM input setup time	tDS	0.45		0.5		0.6		ns	31, j, k

AC Characteristics Parameter	Symbol	DDR 400A (2.5-3-3)		DDR 400B (3-3-3)		DDR 400C (3-4-4)		Units	Notes
		Min	Max	Min	Max	Min	Max		
DQ & DM input setup time	tDS	0.4		0.4		0.4		ns	31

NOTE j: A derating factor will be used to increase tDS and tDH in the case where DQ, DM, and DQS slew rates differ. Input slew rate is based on the larger of AC-AC delta rise, fall rate and DC-DC delta rise, fall rate. Input slew rate is based on the lesser of the slew rates determined by either VIH(AC) to VIL(AC) or VIH(DC) to VIL(DC), similarly for rising transitions.

The delta rise/fall rate is calculated as:

$$\{1/(\text{Slew Rate1})\}-\{1/(\text{Slew Rate2})\}$$

NOTE k: The 1/0 slew rate is based on the lesser of the AC-AC slew rate and the DC-DC slew rate. The input slew rate is based on the lesser of the slew rates determined by either VIH(AC) to VIL(A) or VIH(DC) to VIH(DC), and similarly for rising transitions. A derating factor applies to speed bins DDR 200, DDR 266, and DDR 333.

NOTE 31: If refreshing timing or tDS/tDH is violated, data corruption may occur and the data must be re-written with valid data before a valid READ can be executed.

PASS Condition

The measured time interval between the data or data mask (DQ/DM) setup time to the respective DQS crossing point should be within the specification limit.

Measurement Algorithm

- 1 Obtain the parameters and settings from the Configuration page.
- 2 Pre-condition the scope settings. Verify the actual DUT speed against the user speed selection at the Setup page.
- 3 Perform signal checking on all the signals in-use in the measurement to ensure that it can be triggered during the test. This includes Vp-p, Vmin, Vmax and Vmid of each signal.
- 4 Perform signal skew checking on the DQ-DQS to ensure that it can be triggered during the Read/Write separation later.
- 5 Chip Select (\overline{CS}) option is only applicable if the user has selected “Yes” for the Verify Selected Rank Only option in the Configuration page. It uses the CS-DQS for signal separation. Else, by default, the DQS-DQ is used for signal separation.
- 6 Use the InfiniiScan feature with the Setup time and Hold time to find and capture the Read cycle.
- 7 If you have selected the \overline{CS} option, skip the next step and go to step 9.
- 8 Search for the DQS preamble towards the left from the point where the Write cycle was previously captured. The For loops, TEdge and Delta Time are used to search the preamble.
- 9 Once the preamble is located, call the “BinaryEdgeNormal” function to obtain the Edge number of the rise/fall DQS crossing and Vih_ac/Vil_ac DQ for later TEdge measurement use. This Edge number will be used to locate the point of interest on the specific signal.
- 10 After obtaining the Edge number for the respective signal, begin the tDS(base) measurement bit by bit in the Write data burst. Begin at the 1st bit of the Write cycle, from the Write preamble.
- 11 Continue the measurement until the last bit (for example, until a tristate happens, which indicates the end of a data burst for the respective Write cycle).
- 12 The DQS-DQ timing measurement compares the rising edge (DQ rising, for instance Vih_ac against associated DQS crossing) OR the falling edge (DQ falling, for instance Vil_ac against associated DQS crossing).
- 13 Within the data burst, measure each bit, for instance rising and falling edge of DQS-DQ. Capture the worst case data each time a new value is measured.
- 14 Once all bits are validated, assign marker A for the clock signal while marker B for the data signal, for the worst case bit.
- 15 Measure delta of marker A and marker B and this will be the test result.
- 16 Compare the test result against the compliance test limit.

Test References

See Table 11 - Electrical Characteristics and AC Timing, in the *JEDEC Standard JESD79E*.

tDH(base), DQ and DM Input Hold Time - Test Method of Implementation

The purpose of this test is to verify that the time interval from the data or data mask (DQ/DM rising/falling edge) setup time to the associated DQS crossing edge is within the conformance limits as specified in the *JEDEC Standard JESD79E*.

Signals of Interest

Based on the test definition (Write cycle only):

- Data Signal (DQ as Pin Under Test Signal)
- Clock Signal (CK as Reference Signal)

Signals required to perform the test on the oscilloscope:

- Data Signal (DQ as Pin Under Test Signal)
- Data Strobe Signal (DQS as Supporting Signal)
 - Use differential connection (DQS+ and DQS-)
- Clock Signal (CK as Reference Signal)

Optional signal required to separate the signals for the different Ranks:

- Chip Select Signal ($\overline{\text{CS}}$ as additional signal, which requires an additional channel)

Test Definition Notes from the Specification

Table 59 Electrical Characteristics and AC Timing

AC Characteristics Parameter	Symbol	DDR 333		DDR 266		DDR 200		Units	Notes
		Min	Max	Min	Max	Min	Max		
DQ & DM input hold time	tDH	0.45		0.5		0.6		ns	31, j, k

AC Characteristics Parameter	Symbol	DDR 400A (2.5-3-3)		DDR 400B (3-3-3)		DDR 400C (3-4-4)		Units	Notes
		Min	Max	Min	Max	Min	Max		
DQ & DM input hold time	tDH	0.4		0.4		0.4		ns	31

NOTE j: A derating factor will be used to increase tDS and tDH in the case where DQ, DM, and DQS slew rates differ. Input slew rate is based on the larger of AC-AC delta rise, fall rate and DC-DC delta rise, fall rate. Input slew rate is based on the lesser of the slew rates determined by either VIH(AC) to VIL(AC) or VIH(DC) to VIL(DC), similarly for rising transitions.

The delta rise/fall rate is calculated as:

$$\{1/(\text{Slew Rate1})\}-\{1/(\text{Slew Rate2})\}$$

NOTE k: The 1/0 slew rate is based on the lesser of the AC-AC slew rate and the DC-DC slew rate. The input slew rate is based on the lesser of the slew rates determined by either VIH(AC) to VIL(A) or VIH(DC) to VIH(DC), and similarly for rising transitions. A derating factor applies to speed bins DDR 200, DDR 266, and DDR 333.

NOTE 31: If refreshing timing or tDS/tDH is violated, data corruption may occur and the data must be re-written with valid data before a valid READ can be executed.

PASS Condition

The measured time interval between the data or data mask (DQ/DM) hold time to the respective DQS crossing point should be within the specification limit.

Measurement Algorithm

- 1 Obtain the parameters and settings from the Configuration page.
- 2 Pre-condition the scope settings. Verify the actual DUT speed against the user speed selection at the Setup page.
- 3 Perform signal checking on all the signals in-use in the measurement to ensure that it can be triggered during the test. This includes Vp-p, Vmin, Vmax and Vmid of each signal.
- 4 Perform signal skew checking on the DQ-DQS to ensure that it can be triggered during the Read/Write separation later.
- 5 Chip Select (CS) option is only applicable if the user has selected “Yes” for the Verify Selected Rank Only option in the Configuration page. It uses the CS-DQS for signal separation. Else, by default, the DQS-DQ is used for signal separation.
- 6 Use the InfiniiScan feature with the Setup time and Hold time to find and capture the Read cycle.
- 7 If you have selected the CS option, skip the next step and go to step 9.
- 8 Search for the DQS preamble towards the left from the point where the Write cycle was previously captured. The For loops, TEdge and Delta Time are used to search the preamble.
- 9 Once the preamble is located, call the “BinaryEdgeNormal” function to obtain the Edge number of the rise/fall DQS crossing and the Vih_dc/Vil_dc DQ for the later TEdge measurement use. This Edge number will be used to locate the point of interest on the specific signal.
- 10 After obtaining the Edge number for the respective signal, begin the tDH(base) measurement bit by bit in the Write data burst. Begin at the 1st bit of the Write cycle, from the Write preamble.
- 11 Continue the measurement until the last bit (for example, until a tristate happens, which indicates the end of a data burst for the respective Write cycle).
- 12 The DQS-DQ timing measurement compares the rising edge (DQ rising, for instance Vil_dc against associated DQS crossing) OR the falling edge (DQ falling, for instance Vih_dc against associated DQS crossing).
- 13 Within the data burst, measure each bit, for instance rising and falling edge of the DQS-DQ. Capture the worst case data each time a new value is measured.
- 14 Once all bits are validated, assign marker A for the clock signal while marker B for the data signal, for the worst case bit.
- 15 Measure delta of marker A and marker B and this will be the test result.
- 16 Compare the test result against the compliance test limit.

Test References

See Table 11 - Electrical Characteristics and AC Timing, in the *JEDEC Standard JESD79E*.

10 Command and Address Timing (CAT) Tests

Probing for Command and Address Timing Tests / 142

tIS(base) - Address and Control Input Setup Time - Test Method of Implementation / 145

tIH(base) - Address and Control Input Hold Time - Test Method of Implementation / 147

This section provides the Methods of Implementation (MOIs) for Command and Address Timing tests using an Keysight 54850A, 8000, 80000 or 90000A series Infiniium oscilloscope, recommended InfiniiMax 116xA or 113xA probe amplifiers, E2677A differential solder-in probe head and the DDR1 Compliance Test Application.

NOTE

Both XYZ# and \overline{XYZ} are referring to compliment. Thus, CK# is the same as \overline{CK} .

Probing for Command and Address Timing Tests

When performing the Command and Address Timing tests, the DDR1 Compliance Test Application will prompt you to make the proper connections. The connection for Command and Address Timing tests may look similar to the following diagrams. Refer to the Connection tab in DDR1 Compliance Test Application for the exact number of probe connections. Typically, you need minimum three probe connections to run the tests.

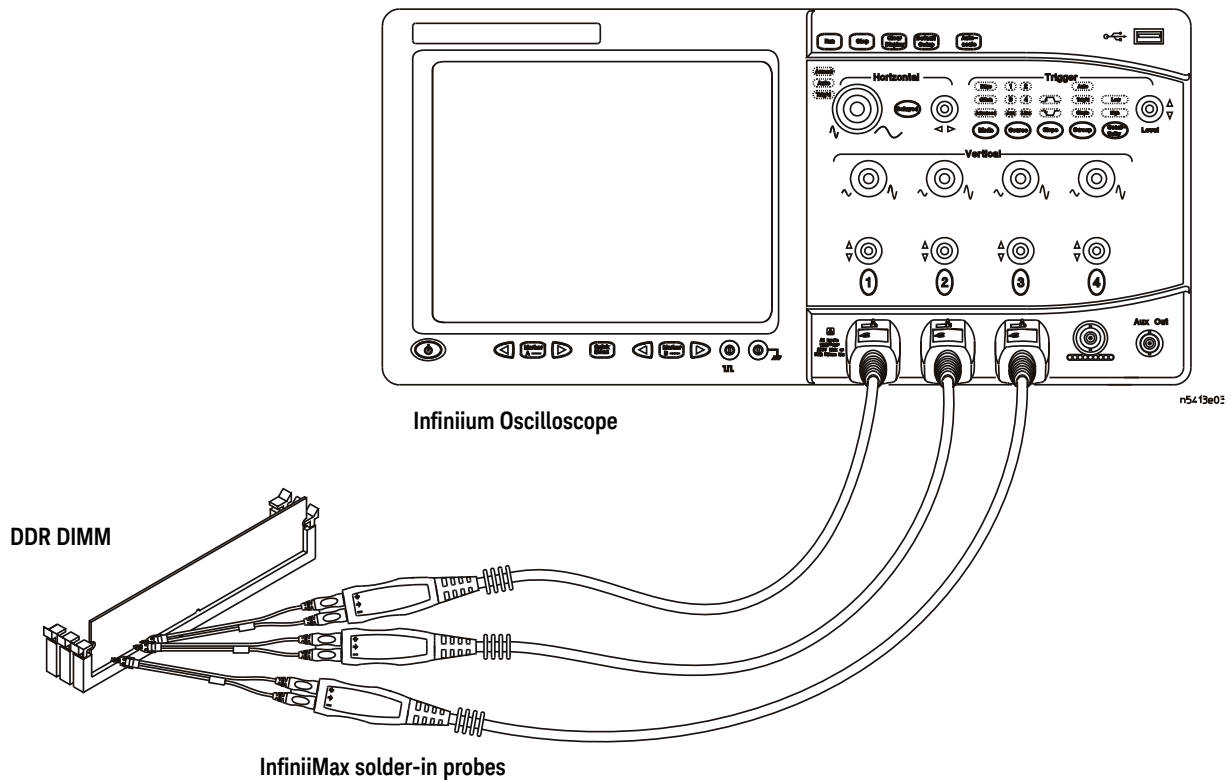

Figure 43 Probing for Command and Address Timing Tests with Three Probes

You can use any of the oscilloscope channels as Pin Under Test (PUT) source channel. You can identify the channels used for each signal in the Configuration tab of the DDR1 Compliance Test Application. (The channels shown in [Figure 43](#) are just examples).

For more information on the probe amplifiers and differential probe heads, see [Chapter 14](#), “InfiniiMax Probing,” starting on page 185.

Test Procedure

- 1 Start the automated test application as described in "Starting the DDR1 Compliance Test Application" on page 27.
- 2 Ensure that the RAM reliability test software is running on the computer system where the DDR Device Under Test (DUT) is attached. This software will perform a test on all unused RAM on the system by producing a repetitive burst of read-write data signals to the DDR memory.
- 3 Connect the differential solder-in probe head to the PUTs on the DDR DIMM.
- 4 Connect the oscilloscope probes to any channels of the oscilloscope.
- 5 In the DDR1 Test Application, click the Set Up tab.
- 6 Select the Speed Grade options. For the Single-Ended Signals AC Input Parameters Tests, you can select any speed grade within the selection: DDR1-200, DDR1-266, DDR1-333, DDR1-400.
- 7 Type in or select the Device Identifier as well as User Description from the drop-down list. Enter your comments in the Comments text box.
- 8 Click the Select Tests tab and check the tests you want to run. Check the parent node or group to check all the available tests within the group.

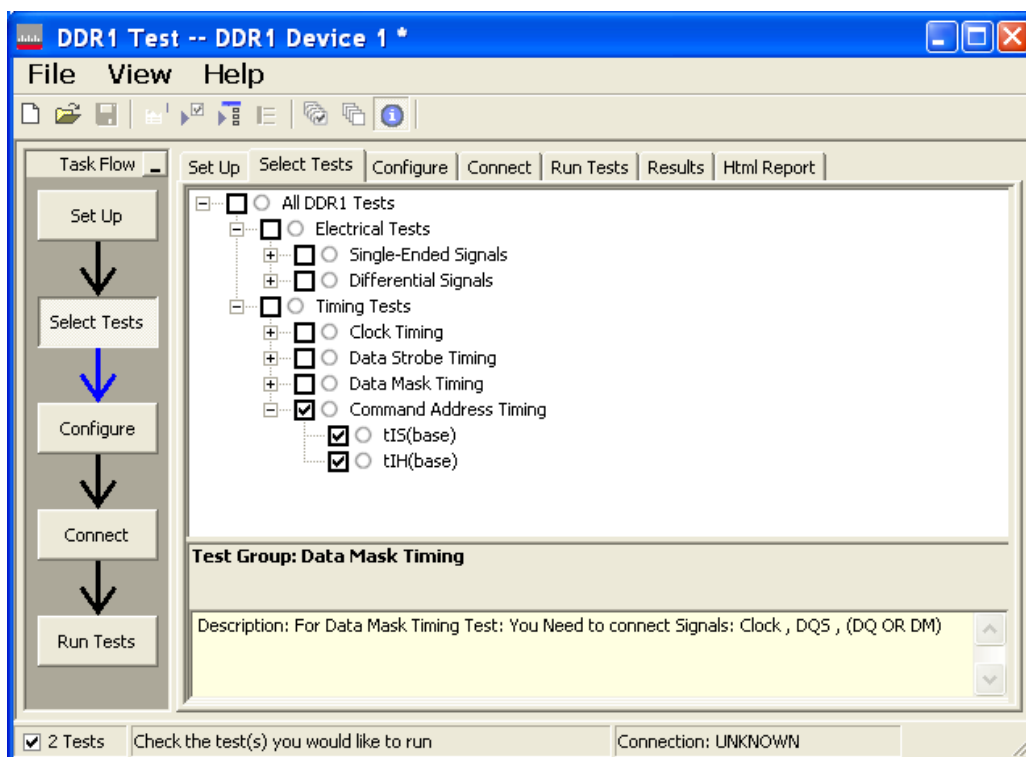

Figure 44 Selecting Command and Address Timing Tests

- 9 Follow the DDR1 Test application's task flow to set up the configuration options (see [Table 60](#)), run the tests and view the tests results.

Table 60 Test Configuration Options

Configuration Option	Description
Stop on error	Enabling this error message will allow error message to prompt whenever criteria is not met. Disabling this option will allow the system to bypass all the error messages that could occur and continue to the next test. This option is suitable for long hours multiple trial.
Signal Threshold setting by percentage	This option allow user to define the Upper and Lower threshold of the signal by percentage.
VDD	Input supply voltage value.
VDDQ	Input supply voltage for data output.
Vref	Input reference voltage value.
Vih(DC)	Input voltage high value (direct current).
Vih(AC)	Input voltage high value (alternating current).
Vil(DC)	Input voltage low value (direct current).
Vil(AC)	Input voltage low value (alternating current).
Timing Tests	
Total Bit Display	Allows user to select the number of data bits to be displayed at the end of the test. Selecting more bits gives a better view of the entire burst of signals.
Total Measurement Required	To perform the total number of measurement based on user selection.
Option	Identifies the signal used for testing.
Pin Under Test, PUT	Signal used for testing.

tIS(base) - Address and Control Input Setup Time - Test Method of Implementation

The purpose of this test is to verify that the time interval from the address or control (rising or falling edge) setup time to the associated clock crossing edge is within the conformance limits of the $V_{ID(ac)}$ as specified in the *JEDEC Standard JESD79E*.

Signals of Interest

Based on the test definition (Read cycle only):

- Address and Control Signal (as Pin Under Test Signal)
- Clock Signal (CK as Reference Signal)

Signals required to perform the test on the oscilloscope:

- Address and Control Signal (as Pin Under Test Signal)
- Clock Signal (CK as Reference Signal)

Test Definition Notes from the Specification

Table 61 Electrical Characteristics and AC Timing

AC Characteristics Parameter	Symbol	DDR 333		DDR 266		DDR 200		Units	Notes
		Min	Max	Min	Max	Min	Max		
Address and Control input setup time (fast slew rate)	tIS	0.75		0.9		1.1		ns	19, 21-23, i
Address and Control input setup time (slow slew rate)	tIS	0.80		1.0		1.1		ns	20-23, j

AC Characteristics Parameter	Symbol	DDR 400A (2.5-3-3)		DDR 400B (3-3-3)		DDR 400C (3-4-4)		Units	Notes
		Min	Max	Min	Max	Min	Max		
Address and Control input setup time (fast slew rate)	tIS	0.60		0.60		0.60		ns	19, 21-23
Address and Control input setup time (slow slew rate)	tIS	0.70		0.70		0.70		ns	20-23

NOTE i: A derating factor will be used to increase tIS and tIH in the case where the input slew rate is below 0.5 V/ns. The input slew rate is based on the lesser of the slew rates determined by either VIH(AC) to VIL(AC) or VIH(DC) to VIL(DC), similarly for rising transitions. A derating factor applies to speed bins DDR 200, DDR 266 and DDR 333.

NOTE 19: For command/address input slew rate ≥ 1.0 V/ns.

NOTE 20: For command/address input slew rate ≥ 0.5 V/ns and < 1.0 V/ns.

NOTE 21: For CK and CK#, slew rate ≥ 1.0 V/ns (single-ended).

NOTE 22: These parameters guarantee device timing, but they are not necessarily tested on each device. They may be guaranteed by device design or tester correlation.

NOTE 23: Slew Rate is measured between VOH(AC) and VOL(AC).

PASS Condition

The measured time interval between the address/control setup time and the respective clock crossing point should be within the specification limit.

Measurement Algorithm

- 1 Obtain the parameters and settings from the Configuration page.
- 2 Pre-condition the scope settings. Verify the actual DUT speed against the user speed selection at the Setup page.
- 3 Perform signal checking on all the signals in-use in the measurement to ensure that it can be triggered during the test. This includes V_{p-p} , V_{min} , V_{max} and V_{mid} of each signal.
- 4 Perform signal skew checking on the CK-DQS.
- 5 tIS measurement will compare the rising edge (address/control rising e.g. V_{ih_ac} against associated clock crossing) OR falling edge (address/control falling e.g. V_{il_ac} against associated clock crossing).
- 6 Assign marker A for the clock signal while marker B for the data signal, for the final measurement result.
- 7 Measure delta of marker A and marker B and this will be the test result.
- 8 Compare the test result against the compliance test limit.

Test References

See Table 11 - Electrical and AC Timing, in the *JEDEC Standard JESD79E*.

tIH(base) – Address and Control Input Hold Time – Test Method of Implementation

The purpose of this test is to verify that the time interval from the address or control (rising or falling edge) hold time to the associated clock crossing edge is within the conformance limits as specified in the *JEDEC Standard JESD79E*.

Signals of Interest

Based on the test definition (Read cycle only):

- Address and Control Signal (as Pin Under Test Signal)
- Clock Signal (CK as Reference Signal)

Signals required to perform the test on the oscilloscope:

- Address and Control Signal (as Pin Under Test Signal)
- Clock Signal (CK as Reference Signal)

Test Definition Notes from the Specification

Table 62 Electrical Characteristics and AC Timing

AC Characteristics Parameter	Symbol	DDR 333		DDR 266		DDR 200		Units	Notes
		Min	Max	Min	Max	Min	Max		
Address and Control input hold time (fast slew rate)	tIH	0.75		0.9		1.1		ns	19, 21-23, i
Address and Control input hold time (slow slew rate)	tIH	0.80		1.0		1.1		ns	20-23, j

AC Characteristics Parameter	Symbol	DDR 400A (2.5-3-3)		DDR 400B (3-3-3)		DDR 400C (3-4-4)		Units	Notes
		Min	Max	Min	Max	Min	Max		
Address and Control input setup time (fast slew rate)	tIH	0.60		0.60		0.60		ns	19, 21-23
Address and Control input setup time (slow slew rate)	tIH	0.70		0.70		0.70		ns	20-23

NOTE i: A derating factor will be used to increase tIS and tIH in the case where the input slew rate is below 0.5 V/ns. The input slew rate is based on the lesser of the slew rates determined by either VIH(AC) to VIL(AC) or VIH(DC) to VIL(DC), similarly for rising transitions. A derating factor applies to speed bins DDR 200, DDR 266 and DDR 333.

NOTE 19: For command/address input slew rate ≥ 1.0 V/ns.

NOTE 20: For command/address input slew rate ≥ 0.5 V/ns and < 1.0 V/ns.

NOTE 21: For CK and CK#, slew rate ≥ 1.0 V/ns (single-ended).

NOTE 22: These parameters guarantee device timing, but they are not necessarily tested on each device. They may be guaranteed by device design or tester correlation.

NOTE 23: Slew Rate is measured between VOH(AC) and VOL(AC).

PASS Condition

The measured time interval between the address/control hold time and the respective clock crossing point should be within the specification limit.

Measurement Algorithm

- 1 Obtain the parameters and settings from the Configuration page.
- 2 Pre-condition the scope settings. Verify the actual DUT speed against the user speed selection at the Setup page.
- 3 Perform signal checking on all the signals in-use in the measurement to ensure that it can be triggered during the test. This includes V_{p-p} , V_{min} , V_{max} and V_{mid} of each signal.
- 4 Perform signal skew checking on the CK-DQS.
- 5 tIH measurement will compare the rising edge (address/control rising e.g. V_{ih_dc} against associated clock crossing) OR falling edge (address/control falling e.g. V_{il_dc} against associated clock crossing).
- 6 Assign marker A for the clock signal while marker B for the data signal, for the final measurement result.
- 7 Measure delta of marker A and marker B and this will be the test result.
- 8 Compare the test result against the compliance test limit.

Test References

See Table 11 - Electrical and AC Timing, in the *JEDEC Standard JESD79E*.

11 Advanced Debug Mode Clock Tests

Probing for Clock Tests / 150

Clock Period Jitter - $t_{JIT(per)}$ - Test Method of Implementation / 154

Cycle to Cycle Period Jitter - $t_{JIT(cc)}$ - Test Method of Implementation / 155

Cumulative Error - $t_{ERR(n\ per)}$ - Test Method of Implementation / 156

Half Period Jitter - $t_{JIT(duty)}$ - Test Method of Implementation / 157

This section provides the Methods of Implementation (MOIs) for Rising Edge and Pulse Measurements Clock tests using an Keysight 54850A, 8000, 80000 or 90000A series Infiniium oscilloscope, recommended InfiniMax 116xA or 113xA probe amplifiers, E2677A differential solder-in probe head and the DDR1 Compliance Test Application.

Probing for Clock Tests

When performing the Advanced Debug Mode Clock tests, the DDR1 Compliance Test Application will prompt you to make the proper connections. The connections for Rising Edge and Pulse Measurement Clock tests may look similar to the following diagram. Refer to the Connection tab in DDR1 Electrical Performance Compliance application for the exact number of probe connections.

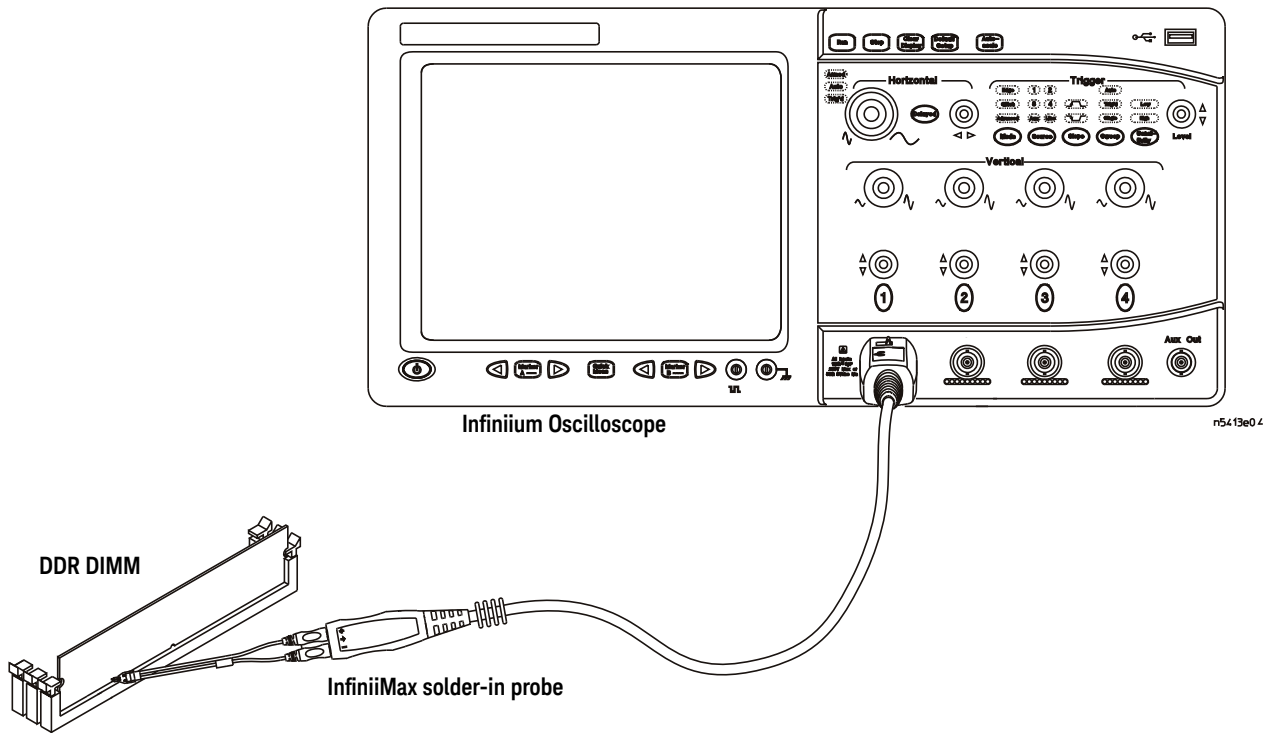

Figure 45 Probing for Measurement Clock Tests

You can use any of the oscilloscope channels as the Pin Under Test (PUT) source channel. You can identify the channels used for each signal in the Configuration tab of the DDR1 Compliance Test Application. (The channel shown in [Figure 45](#) is just an example.)

For more information on the probe amplifiers and differential probe heads, see [Chapter 14](#), “InfiniMax Probing,” starting on page 185.

Test Procedure

- 1 Start the automated test application as described in [“Starting the DDR1 Compliance Test Application”](#) on page 27.
- 2 Ensure that the RAM reliability test software is running on the computer systems where the DDR Device Under Test (DUT) is attached. This software will perform tests on all the unused RAM in the system by producing repetitive bursts of read-write data signals to the DDR memory.
- 3 Connect the differential solder-in probe head to the PUT on the DDR DIMM.
- 4 Connect the oscilloscope probes to any of the oscilloscope channels.

- 5 In the DDR1 test application, click the Set Up tab.
- 6 Select Advanced Debug as the Test Mode option.

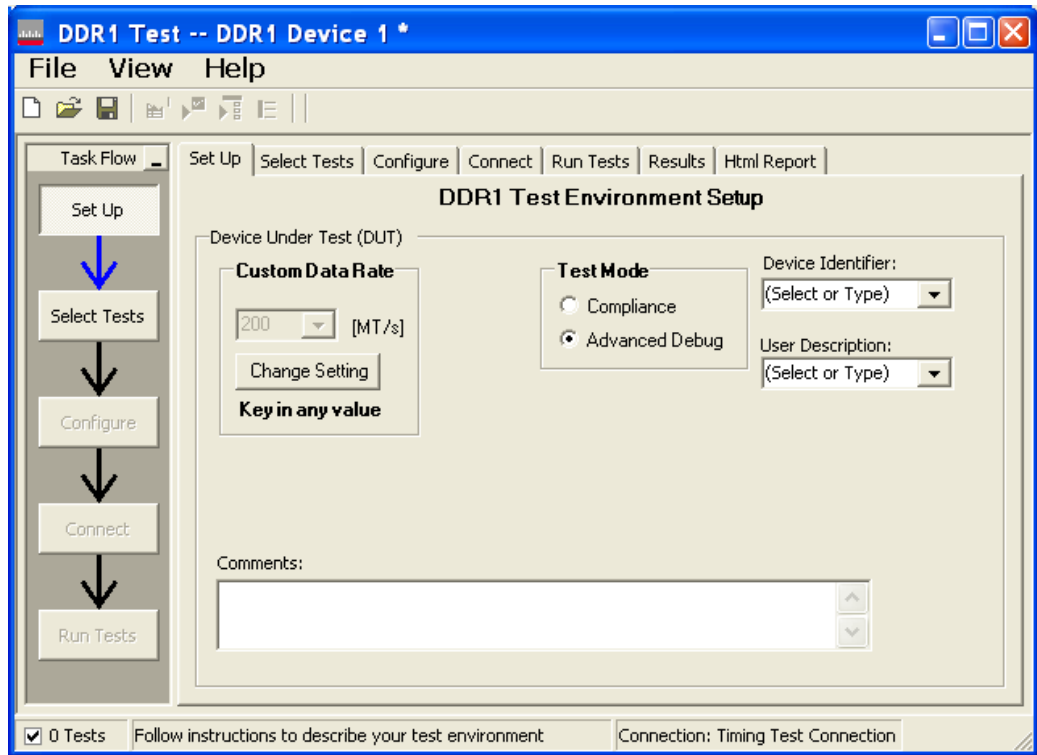

Figure 46 Selecting Advanced Debug Mode

- 7 Advanced Debug also allows you to type in the data rate of the DUT signal.
- 8 Type in or select the Device Identifier as well as the User Description from the drop-down list. Enter your comments in the Comments text box.
- 9 Click the Select Tests tab and check the tests you want to run. Check the parent node or group to check all the available tests within the group.

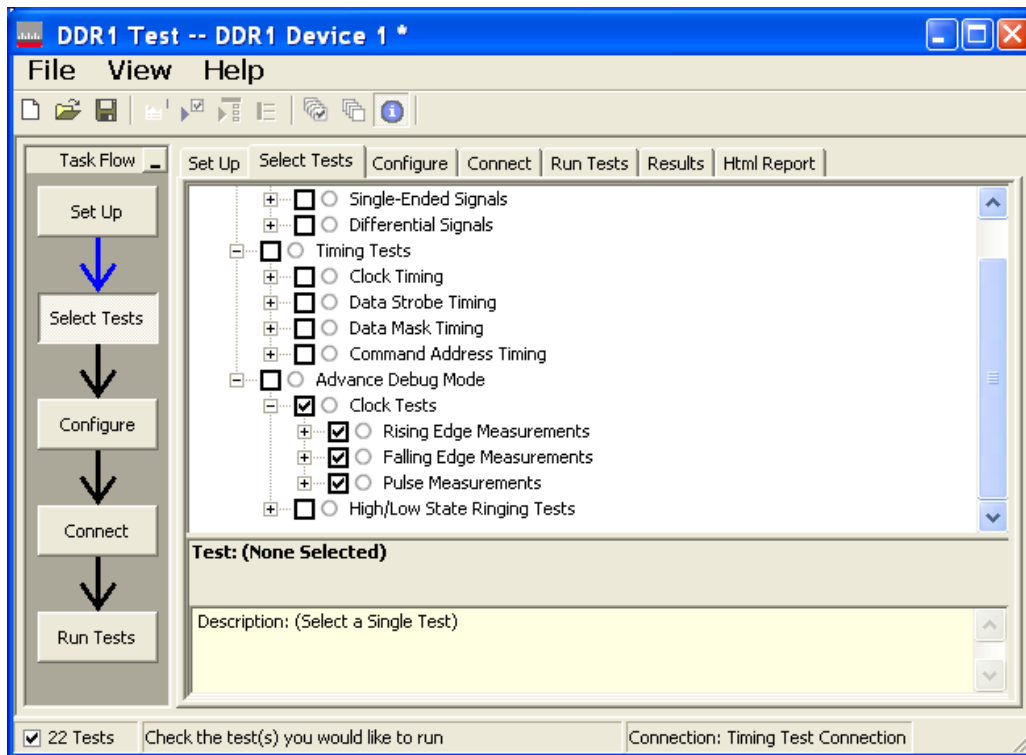

Figure 47 Selecting Advanced Debug Clock Tests

- 10 Follow the DDR1 Test application's task flow to set up the configuration options (see [Table 63](#)), run the tests and view the tests results.

Table 63 Test Configuration Options

Configuration Option	Description
Stop on error	Enabling this error message will allow error message to prompt whenever criteria is not met. Disabling this option will allow the system to bypass all the error messages that could occur and continue to the next test. This option is suitable for long hours multiple trial.
Signal Threshold setting by percentage	This option allow user to define the Upper and Lower threshold of the signal by percentage.
VDD	Input supply voltage value.
VDDQ	Input supply voltage for data output.
Vref	Input reference voltage value.
Vih(dc)	Input voltage high value (direct current).
Vih(ac)	Input voltage high value (alternating current).
Vil(dc)	Input voltage low value (direct current).
Vil(ac)	Input voltage low value (alternating current).
Waveform Source	Identifies the source of the data to be analyzed.
Use Recommended Memory Depth	Sets the Memory Depth to the maximum recommended value: 2 Mpts (DSO80000 series) or 1 Mpts (DSO548xx series). Select "No" if you plan to manually select the memory depth.
	Sets the Sampling Rate to 20 GSa and Bandwidth to AUTO. Select "No" if you plan to manually select sampling rate or bandwidth settings.
Worst Case Tracking	
Mark Worst Case Cycle	Places markers around the worst case cycles (test-dependent). Slows runtime performance.
terr(nper) SubWindow Range	
terr(nper) Minimum N Width Value	Sets the lower bound (inclusive) of the inner sliding window for the terr(nper) series.
terr(nper) Maximum N Width Value	Sets the upper bound (inclusive) of the inner sliding window for the terr(nper) series.

Clock Period Jitter - tJIT(per) - Test Method of Implementation

This test is applicable to the Rising Edge Measurement and Falling Edge Measurement. The purpose of this test is to measure the difference between a measured clock period and the average clock period across multiple cycles of the clock. You can specify the rising and/or the falling edge of your signal for this measurement.

Signals of Interest

Based on the test definition (Read cycle only):

- Clock Signal

Signals required to perform the test on the oscilloscope:

- Clock Signal - CK is required to perform pre-test to verify the DUT speed against user's speed grade selection

Measurement Algorithm

Example input test signal: Frequency: 1 KHz, Number of cycles acquired: 202.

- 1 This measurement measures the difference between every period inside a 200 cycle window with the average of the whole window.
- 2 Compare periods with the new average.
- 3 Check the results for the smallest and largest values (worst case values).
- 4 Compare the test results against the compliance test limits.

Cycle to Cycle Period Jitter - $t_{JIT(cc)}$ - Test Method of Implementation

This test is applicable to the Rising Edge Measurement as well as Falling Edge Measurement. The purpose of this test is to measure the difference in the clock period between two consecutive clock cycles. The $t_{JIT(cc)}$ Rising Edge Measurement measures the clock period from the rising edge of a clock cycle to the next rising edge. The $t_{JIT(cc)}$ Falling Edge Measurement measures the clock period from the falling edge to falling edge. The test will show a fail status if the total failed waveforms is greater than 0.

Signals of Interest

Based on the test definition:

- Clock Signal

Signals required to perform the test on the oscilloscope:

- Clock Signal - CK is required to perform pre-test to verify the DUT speed against user's speed grade selection

Measurement Algorithm

Example input test signal: Frequency: 1 KHz, Number of cycles acquired: 202.

- 1 Measure the difference between every adjacent pair of periods.
- 2 Generate 201 measurement results.
- 3 Check the results for the smallest and largest values (worst case values).
- 4 Compare the test results against the compliance test limits.

Cumulative Error - tERR(n per) - Test Method of Implementation

This Cumulative Error (across “n” cycles) test is applicable to the Rising Edge Measurement as well as the Falling Edge Measurement. The purpose of this test is to measure the difference between a measured clock period and the average clock period across multiple cycles of the clock.

Signals of Interest

Based on the test definition:

- Clock Signal

Signals required to perform the test on the oscilloscope:

- Clock Signal - CK is required to perform pre-test to verify the DUT speed against user’s speed grade selection

Measurement Algorithm

Example input test signal: Frequency: 1 KHz, Number of cycles acquired: 202.

- 1 tERR(2per) is similar to tJIT(per), except it makes a small 2-cycle window inside the big 200 cycle window and compares the average of the small window with the average of the big window.
- 2 Check the results for the smallest and largest values (worst case values).
- 3 Compare the results against the compliance test limits.
- 4 tERR(3per) is the same as tERR(2per) except the small window size is 3 periods wide. tERR(4per) uses small window size of 4 periods and tERR(5per) uses 5 periods.
- 5 tERR(6-10per) executes tERR(6per), tERR(7per), tERR(8per), tERR(9per) and tERR(10per), combines all the measurement results together into one big pool and checks for the smallest and largest value.
- 6 tERR(11-50per) does the same for tERR(11per) through tERR(50per).

Half Period Jitter - tJIT(duty) - Test Method of Implementation

The Half Period Jitter tJIT(duty) can be divided into tJIT(CH) Jitter Average High and tJIT(LH) Jitter Average Low. The tJIT(CH) Jitter Average High Measurement measures between a positive pulse width of a cycle in the waveform, and the average positive pulse width of all cycles in a 200 consecutive cycle window. tJIT(LH) Jitter Average Low Measurement measures between a negative pulse width of a cycle in the waveform and the average negative pulse width of all cycles in a 200 consecutive cycle window.

Signals of Interest

Based on the test definition:

- Clock Signal

Signals required to perform the test on the oscilloscope:

- Clock Signal - CK is required to perform pre-test to verify the DUT speed against user's speed grade selection

Measurement Algorithm

Example input test signal: Frequency: 1 KHz, Number of cycles acquired: 202.

tJIT(CH)

- 1 This measurement measures the difference between every high pulse width inside a 200 cycle window with the average of the whole window.
- 2 Measure the difference between high pulse width, and the average. Save the answer as the measurement result.
- 3 Compare the high pulse width with the new average.
- 4 Check the results for the smallest and largest values (worst case values).
- 5 Compare the test results against the compliance test limits.

tJIT(LH)

- 1 This measurement is similar to tJIT(CH) above except, instead of using high pulse widths, it uses low pulse widths for testing comparison.

12 Advanced Debug Mode High-Low State Ringing Tests

Probing for Advanced Debug Mode High-Low State Ringing Tests / 160
High State Ringing Tests Method of Implementation / 164
Low State Ringing Tests Method of Implementation / 166

This section provides the Methods of Implementation (MOIs) for Advanced Debug Mode High-Low State Ringing tests using an Keysight 54850A, 8000, 80000 or 90000A series Infiniium oscilloscope, recommended InfiniiMax 116xA or 113xA probe amplifiers, E2677A differential solder-in probe head and the DDR1 Compliance Test Application.

Probing for Advanced Debug Mode High-Low State Ringing Tests

When performing the intra-pair skew tests, the DDR1 Compliance Test Application will prompt you to make the proper connections as shown in [Figure 48](#).

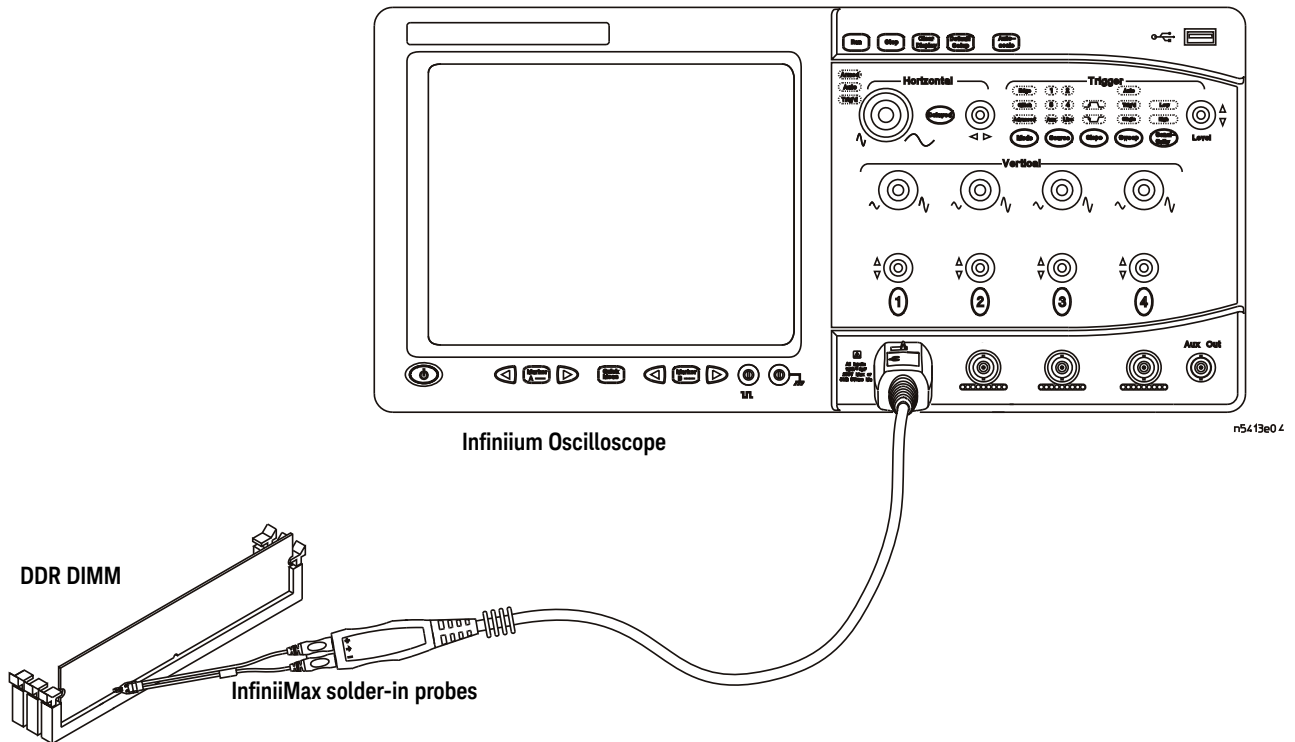

Figure 48 Probing for Advanced Debug Mode High-Low State Ringing Tests

You can use any of the oscilloscope channels as the Pin Under Test (PUT) source channel. You identify the channels used for each signal in the Configuration tab of the DDR1 Compliance Test Application. (The channel shown in [Figure 48](#) is just an example.)

For more information on the probe amplifiers and differential probe heads, see [Chapter 14](#), “InfiniiMax Probing,” starting on page 185.

Test Procedure

- 1 Start the automated test application as described in [“Starting the DDR1 Compliance Test Application”](#) on page 27.
- 2 Ensure that the RAM reliability test software is running on the computer systems where the DDR Device Under Test (DUT) is attached. This software will perform tests on all the unused RAM in the system by producing repetitive bursts of read-write data signals to the DDR memory.
- 3 Connect the differential solder-in probe head to the PUT on the DDR DIMM.
- 4 Connect the oscilloscope probes to any of the oscilloscope channels.
- 5 In the DDR1 test application, click the Set Up tab.
- 6 Select Advanced Debug as the Test Mode option.

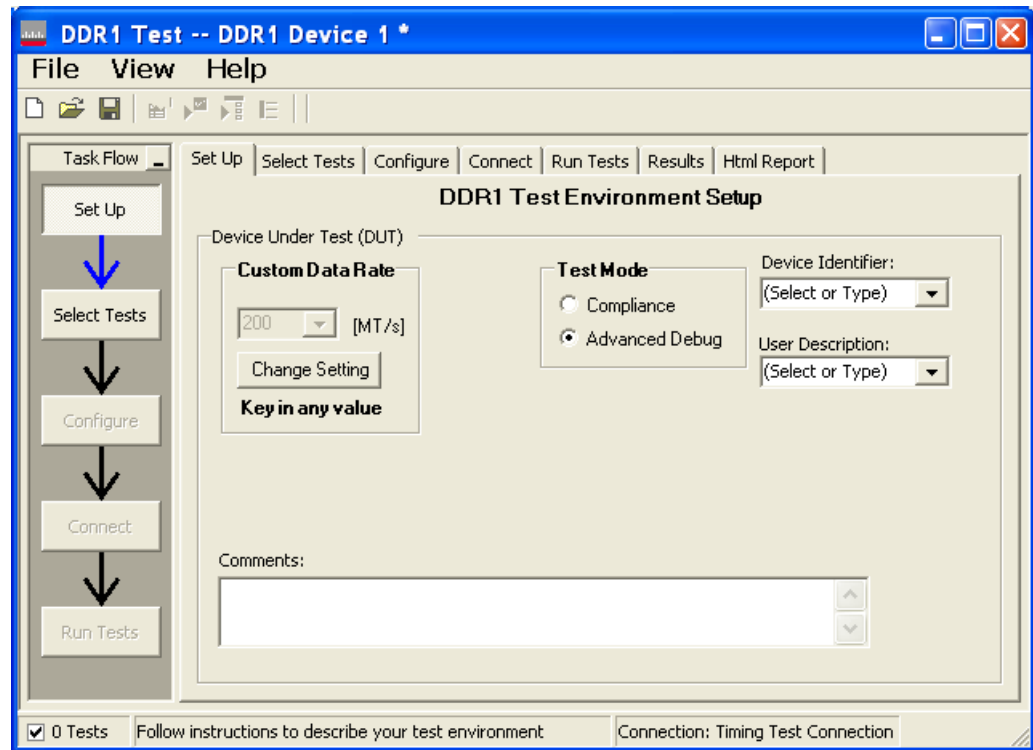

Figure 49 Selecting Advanced Debug Mode

- 7 Advanced Debug also allows you to type in the data rate of the DUT signal.
- 8 Type in or select the Device Identifier as well as the User Description from the drop-down list. Enter your comments in the Comments text box.
- 9 Click the Select Tests tab and check the tests you want to run. Check the parent node or group to check all the available tests within the group.

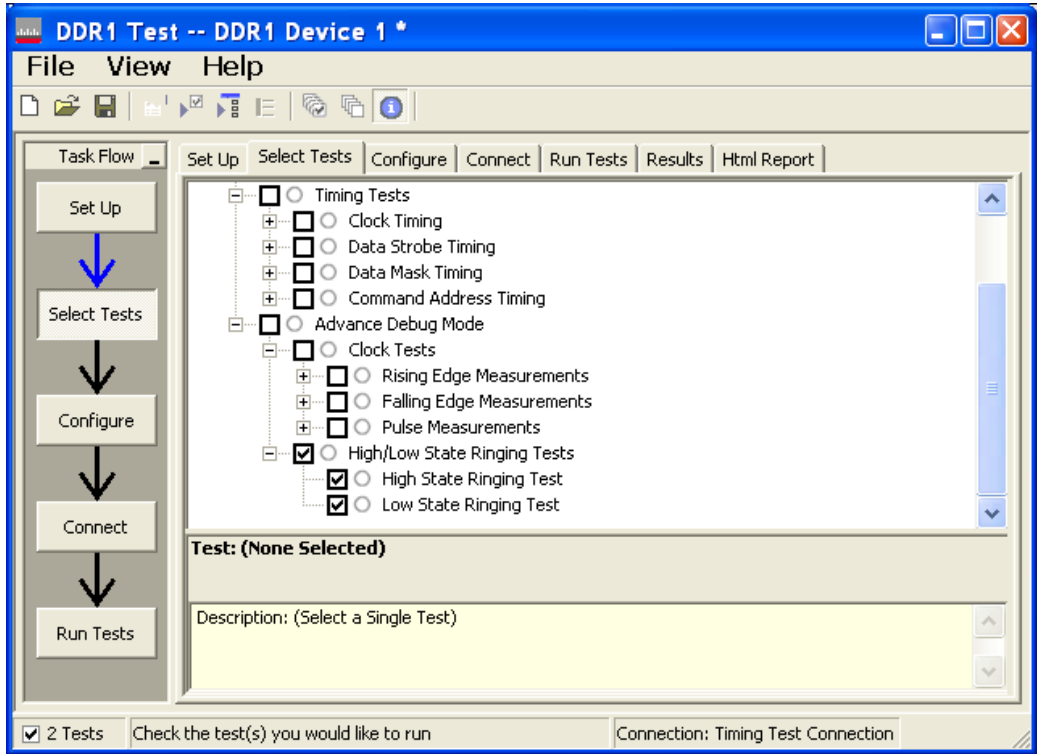

Figure 50 Selecting Advanced Debug High-Low State Ringing Tests

- 10 Follow the DDR1 Test application's task flow to set up the configuration options (see Table 64), run the tests and view the tests results.

Table 64 Test Configuration Options

Configuration Option	Description
Stop on error	Enabling this error message will allow error message to prompt whenever criteria is not met. Disabling this option will allow the system to bypass all the error messages that could occur and continue to the next test. This option is suitable for long hours multiple trial.
Signal Threshold setting by percentage	This option allow user to define the Upper and Lower threshold of the signal by percentage.
VDD	Input supply voltage value.
VDDQ	Input supply voltage for data output.
Vref	Input reference voltage value.
Vih(DC)	Input voltage high value (direct current).
Vih(AC)	Input voltage high value (alternating current).
Vil(DC)	Input voltage low value (direct current).
Vil(AC)	Input voltage low value (alternating current).
Advanced Debug Mode	
Pin Under Test, PUT	Identifies the Pin Under Test for High/Low State Ringing tests
PUT Source	Identifies the source of the PUT for High-Low State Ringing tests.
Time-out	Identifies the time-out value to be used for High-Low State Ringing Test.
Trigger Level	Sets the rising edge voltage level to trigger on for all High-Low State Ringing Test.
Upper Level	Identifies the upper threshold level to be used for the ringing tests.
	Identifies the hysteresis value to be used for the ringing test.
Lower Level	Identifies the lower threshold level to be used for the ringing tests.

High State Ringing Tests Method of Implementation

The Advanced Debug Mode Ringing test can be divided into two sub-tests. One of them is the High State Ringing test. There is no available specification for this test in the *JEDEC Standard JESD79E* specifications. The ringing debug test is definable by the customers to capture the glitch of interest for the logic high state section in a test signal for evaluation purposes. The purpose of this test is to automate all the required setup procedures, particularly the InfiniiScan RUNT mode setup, to capture the ringing section of a test signal. Users are required to customize the threshold value in the Configure tab to capture the specific RUNT signals. The expected results are signals captured on the screen that fulfill the InfiniiScan RUNT criteria. There is a pulse in the captured signal that passes through two voltage level threshold but not the third.

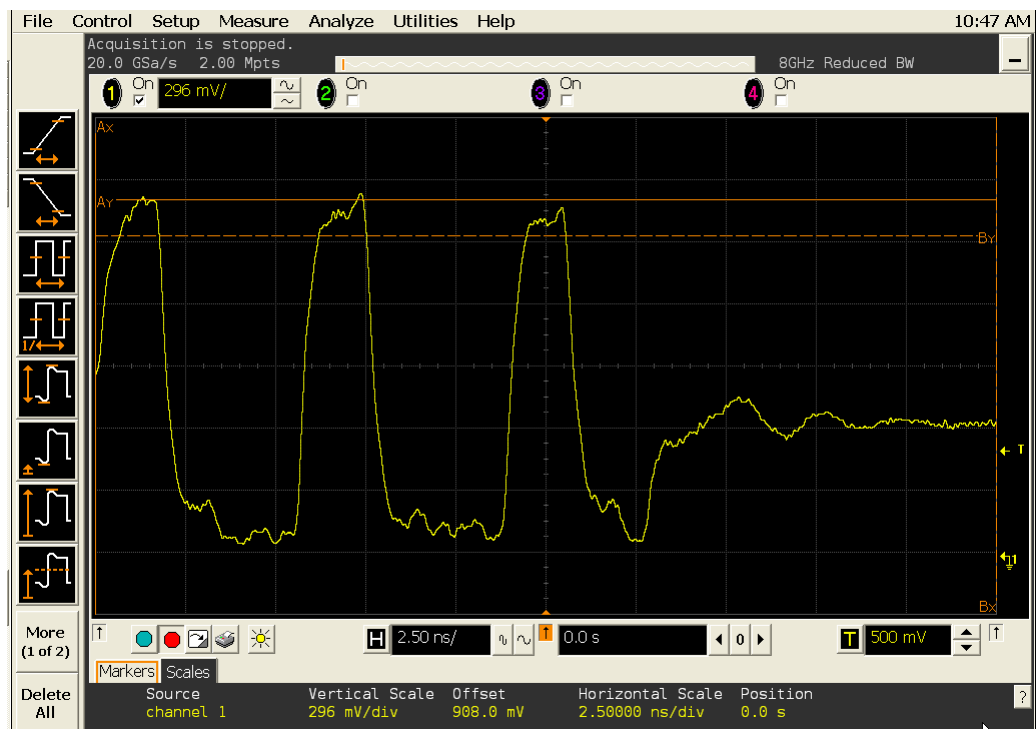

Figure 51 High State Ringing Test

Signals of Interest

Based on the test definition (Write cycle only):

- Data Signals OR
- Data Strobe Signals OR
- Address Signals OR
- Control Signal OR
- Data Mask Control Signals

Signals required to perform the test on the oscilloscope:

- Data Signal (DQ as Pin Under Test Signal)
- Clock Signal - CK is required to perform pre-test to verify the DUT speed against the user's speed grade selection

Measurement Algorithm

- 1 Acquire initial signal data and then perform signal conditioning to maximize the screen resolution - vertical scale adjustment.
- 2 Setup the InfiniiScan to activate the RUNT mode.
- 3 Acquire test data with the InfiniiScan RUNT activated.
- 4 Display Markers to show the RUNT Upper Level and RUNT Lower Level.

Low State Ringing Tests Method of Implementation

Just as the High State Ringing test, there is no available specification in the *JEDEC Standard JESD79E* specifications for the Low State Ringing tests. The ringing debug test is definable by the customers to capture the glitch of interest for the logic low state section in a test signal for evaluation purposes. The purpose of this test is to automate all the required setup procedures, particularly the InfiniiScan RUNT mode setup, to capture the ringing section of a test signal. Users are required to customize the threshold value in the Configure tab to capture the specific RUNT signals. The expected results are signals captured on the screen that fulfill the InfiniiScan RUNT criteria. There is a pulse in the captured signal that passes through two voltage level threshold but not the third.

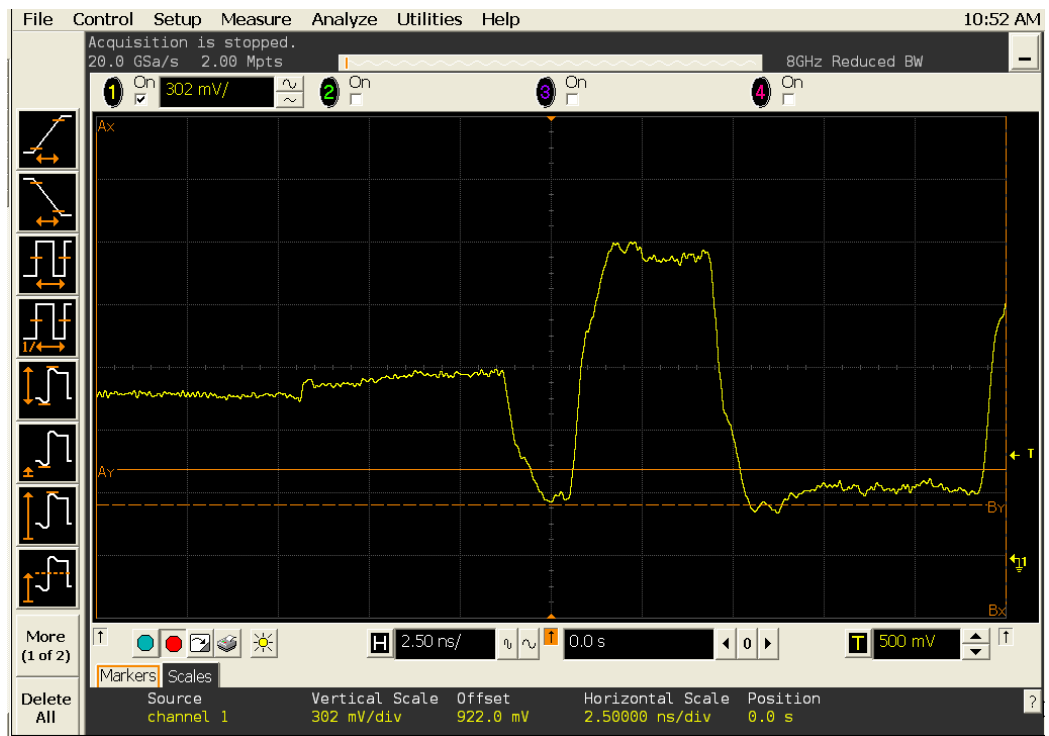

Figure 52 Low State Ringing Test

Signals of Interest

Based on the test definition (Write cycle only):

- Data Signals OR
- Data Strobe Signals OR
- Address Signals OR
- Control Signal OR
- Data Mask Control Signals

Signals required to perform the test on the oscilloscope:

- Data Signal (DQ as Pin Under Test Signal)
- Clock Signal - CK is required to perform pre-test to verify the DUT speed against user's speed grade selection

Measurement Algorithm

- 1 Acquire initial signal data and then perform signal conditioning to maximize the screen resolution - vertical scale adjustment.
- 2 Setup the InfiniiScan to activate the RUNT mode.
- 3 Acquire test data with the InfiniiScan RUNT activated.
- 4 Display Markers to show the RUNT Upper Level and RUNT Lower Level.

13 Calibrating the Infiniium Oscilloscope and Probe

Required Equipment for Oscilloscope Calibration / 170

Internal Calibration / 171

Required Equipment for Probe Calibration / 174

Probe Calibration / 175

Verifying the Probe Calibration / 182

This section describes the Keysight Infiniium digital storage oscilloscope calibration procedures.

Required Equipment for Oscilloscope Calibration

To calibrate the Infiniium oscilloscope in preparation for running the DDR1 automated tests, you need the following equipment:

- Keyboard, qty = 1, (provided with the Keysight Infiniium oscilloscope).
- Mouse, qty = 1, (provided with the Keysight Infiniium oscilloscope).
- Precision 3.5 mm BNC to SMA male adapter, Keysight p/n 54855-67604, qty = 2 (provided with the Keysight Infiniium oscilloscope).
- Calibration cable (provided with the 54850A, 8000, 80000 or 90000A series Infiniium oscilloscopes). Use a good quality 50 Ω BNC cable.
- BNC shorting cap (provided with the 54850A series Infiniium oscilloscopes).

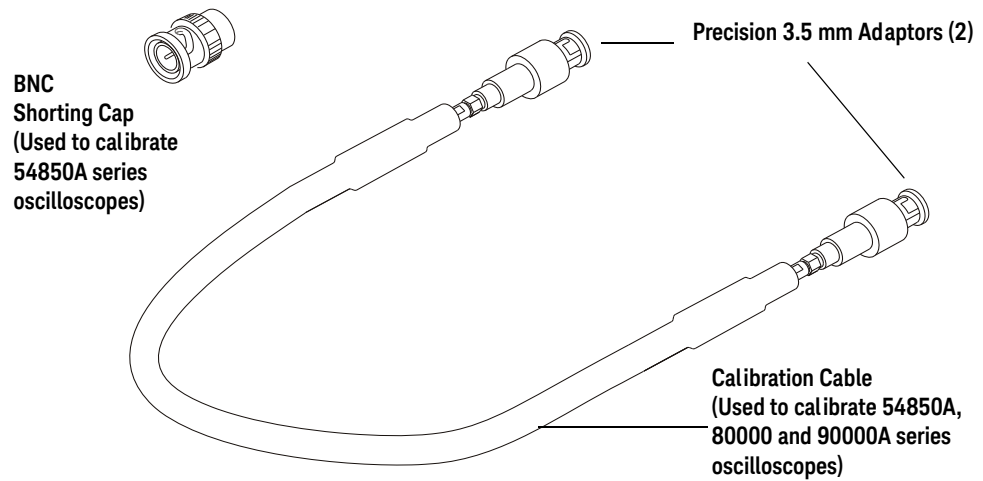

Figure 53 Accessories Provided with the Keysight Infiniium Oscilloscope

Internal Calibration

This will perform an internal diagnostic and calibration cycle for the oscilloscope. For the Keysight oscilloscope, this is referred to as Calibration. This Calibration will take about 20 minutes. Perform the following steps:

- 1 Set up the oscilloscope with the following steps:
 - a Connect the keyboard, mouse, and power cord to the rear of the oscilloscope.
 - b Plug in the power cord.
 - c Turn on the oscilloscope by pressing the power button located on the lower left of the front panel.
 - d Allow the oscilloscope to warm up at least 30 minutes prior to starting the calibration procedure in step 3 below.
- 2 Locate and prepare the accessories that will be required for the internal calibration:
 - a Locate the BNC shorting cap.
 - b Locate the calibration cable.
 - c Locate the two Keysight precision SMA/BNC adapters.
 - d Attach one SMA adapter to the other end of the calibration cable - hand tighten snugly.
 - e Attach another SMA adapter to the other end of the calibration cable - hand tighten snugly.
- 3 Referring to [Figure 54](#) below, perform the following steps:
 - a Click on the Utilities>Calibration menu to open the Calibration dialog box.

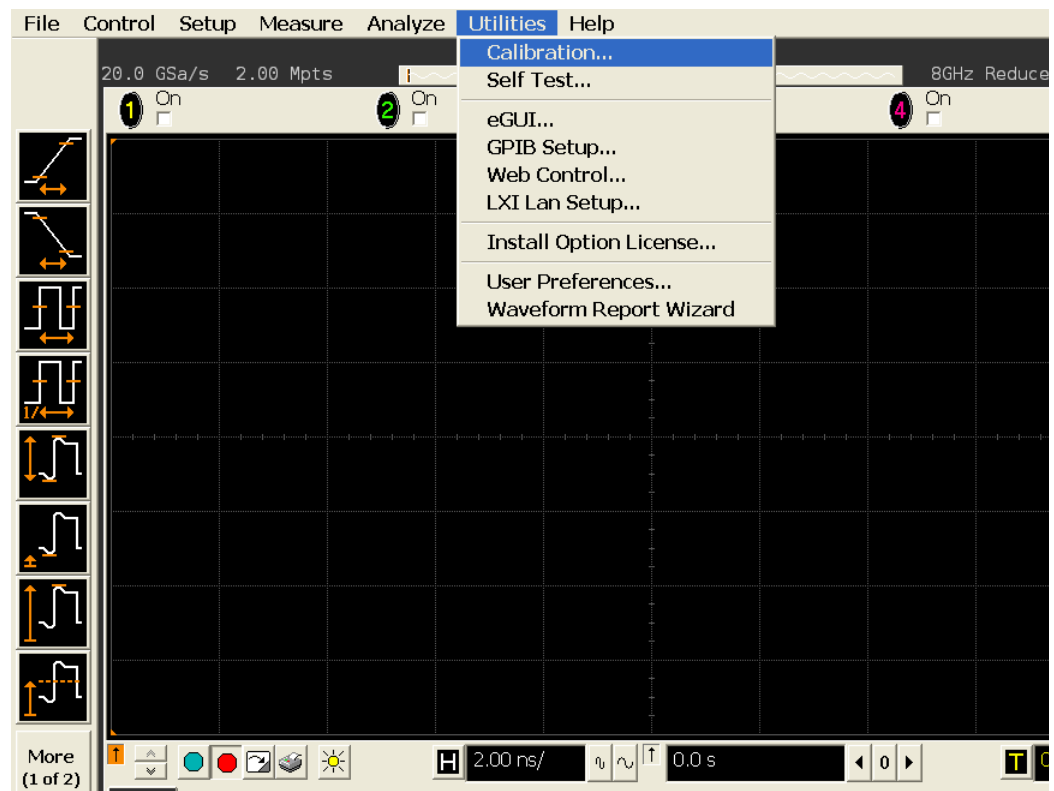

Figure 54 Accessing the Calibration Menu

- 4 Referring to **Figure 55** below, perform the following steps to start the calibration:
 - b Uncheck the Cal Memory Protect checkbox.
 - c Click the Start button to begin the calibration.

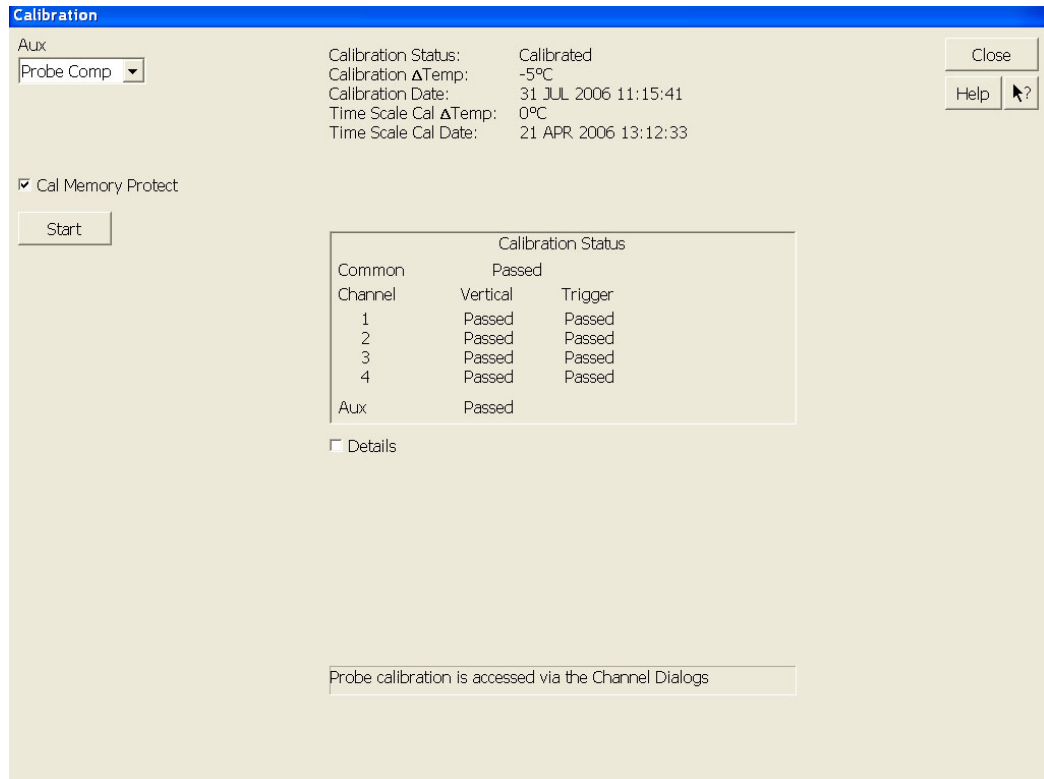

Figure 55 Oscilloscope Calibration Window

- d* During the calibration of channel 1, if you are prompted to perform a Time Scale Calibration, as shown in [Figure 56](#) below.

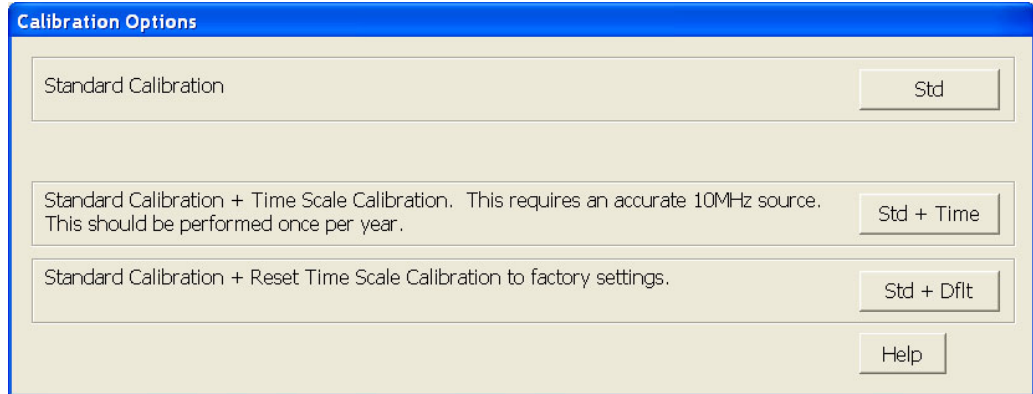

Figure 56 Time Scale Calibration Dialog box

- e* Click on the Std+Dflt button to continue the calibration, using the Factory default calibration factors.
- f* When the calibration procedure is complete, you will be prompted with a Calibration Complete message window. Click the OK button to close this window.
- g* Confirm that the Vertical and Trigger Calibration Status for all Channels passed.
- h* Click the Close button to close the calibration window.
- i* The internal calibration is completed.
- j* Read NOTE below.

NOTE

These steps do not need to be performed every time a test is run. However, if the ambient temperature changes more than 5 degrees Celsius from the calibration temperature, this calibration should be performed again. The delta between the calibration temperature and the present operating temperature is shown in the Utilities>Calibration menu.

Required Equipment for Probe Calibration

Before performing DDR1 tests you should calibrate the probes. Calibration of the solder-in probe heads consist of a vertical calibration and a skew calibration. The vertical calibration should be performed before the skew calibration. Both calibrations should be performed for best probe measurement performance.

The calibration procedure requires the following parts.

- BNC (male) to SMA (male) adaptor
- Deskew fixture
- 50 Ω SMA terminator

Probe Calibration

Connecting the Probe for Calibration

For the following procedure, refer to [Figure 57](#) below.

- 1 Connect BNC (male) to SMA (male) adaptor to the deskew fixture on the connector closest to the yellow pincher.
- 2 Connect the 50 Ω SMA terminator to the connector farthest from yellow pincher.
- 3 Connect the BNC side of the deskew fixture to the Aux Out BNC of the Infiniium oscilloscope.
- 4 Connect the probe to an oscilloscope channel.
- 5 To minimize the wear and tear on the probe head, it should be placed on a support to relieve the strain on the probe head cables.
- 6 Push down the back side of the yellow pincher. Insert the probe head resistor lead underneath the center of the yellow pincher and over the center conductor of the deskew fixture. The negative probe head resistor lead or ground lead must be underneath the yellow pincher and over one of the outside copper conductors (ground) of the deskew fixture. Make sure that the probe head is approximately perpendicular to the deskew fixture.
- 7 Release the yellow pincher.

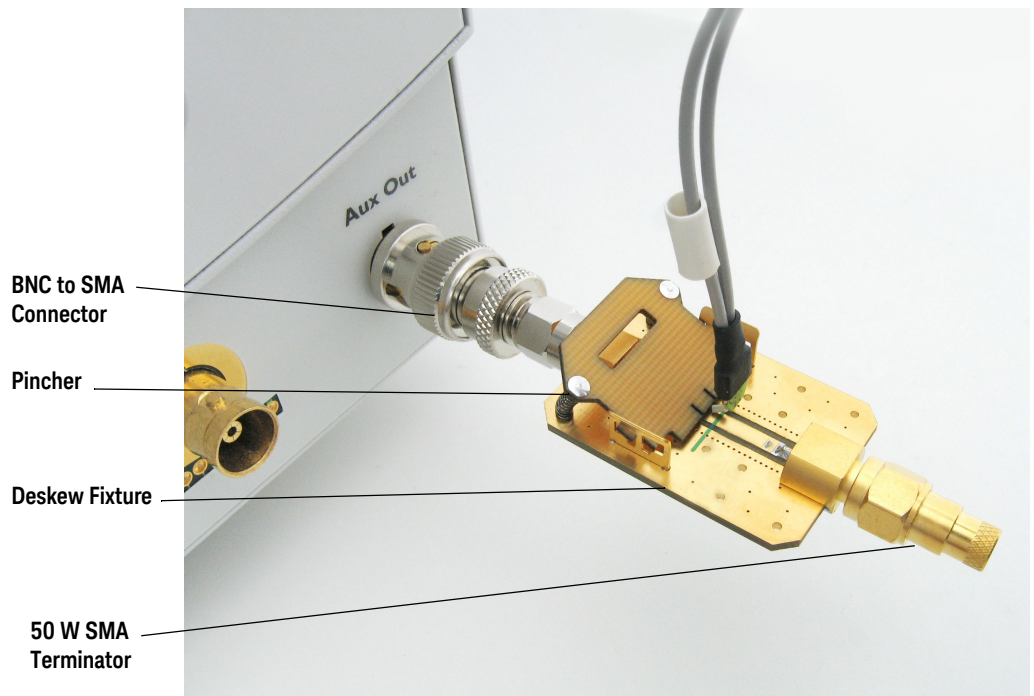

Figure 57 Solder-in Probe Head Calibration Connection Example

Verifying the Connection

- 1 On the Infiniium oscilloscope, press the autoscale button on the front panel.
- 2 Set the volts per division to 100 mV/div.
- 3 Set the horizontal scale to 1.00 ns/div.
- 4 Set the horizontal position to approximately 3 ns. You should see a waveform similar to that in Figure 58 below.

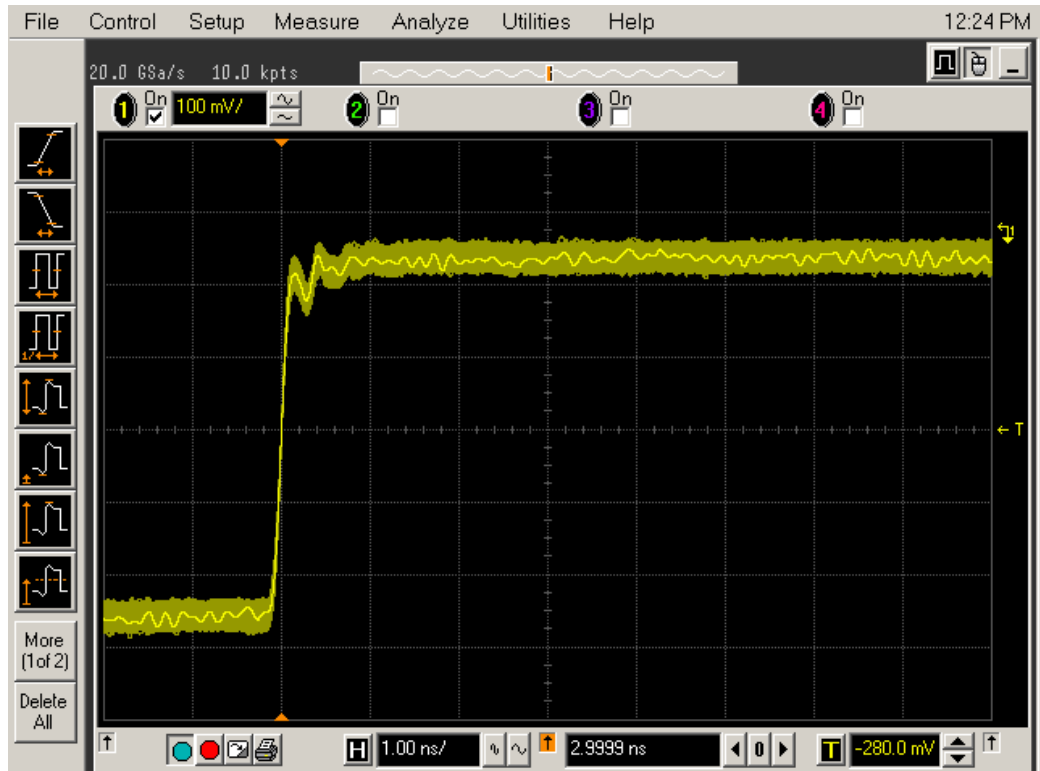

Figure 58 Good Connection Waveform Example

If you see a waveform similar to that of Figure 59 below, then you have a bad connection and should check all of your probe connections.

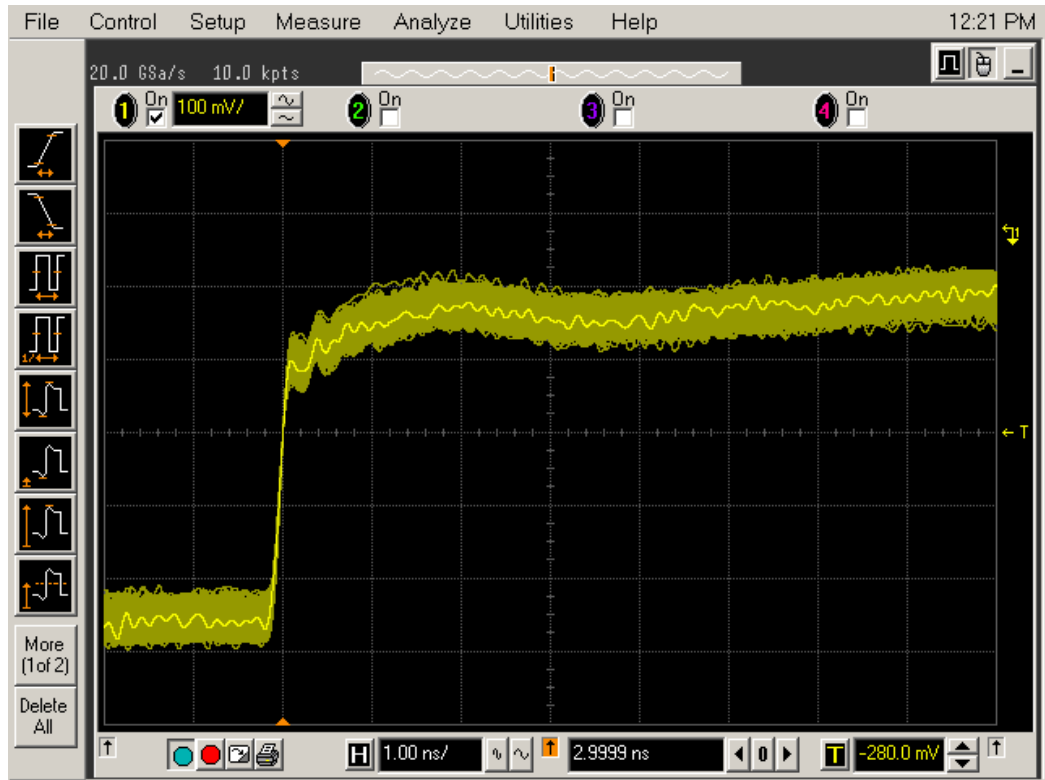

Figure 59 Bad Connection Waveform Example

Running the Probe Calibration and Deskew

- 1 On the Infiniium oscilloscope in the Setup menu, select the channel connected to the probe, as shown in Figure 60.

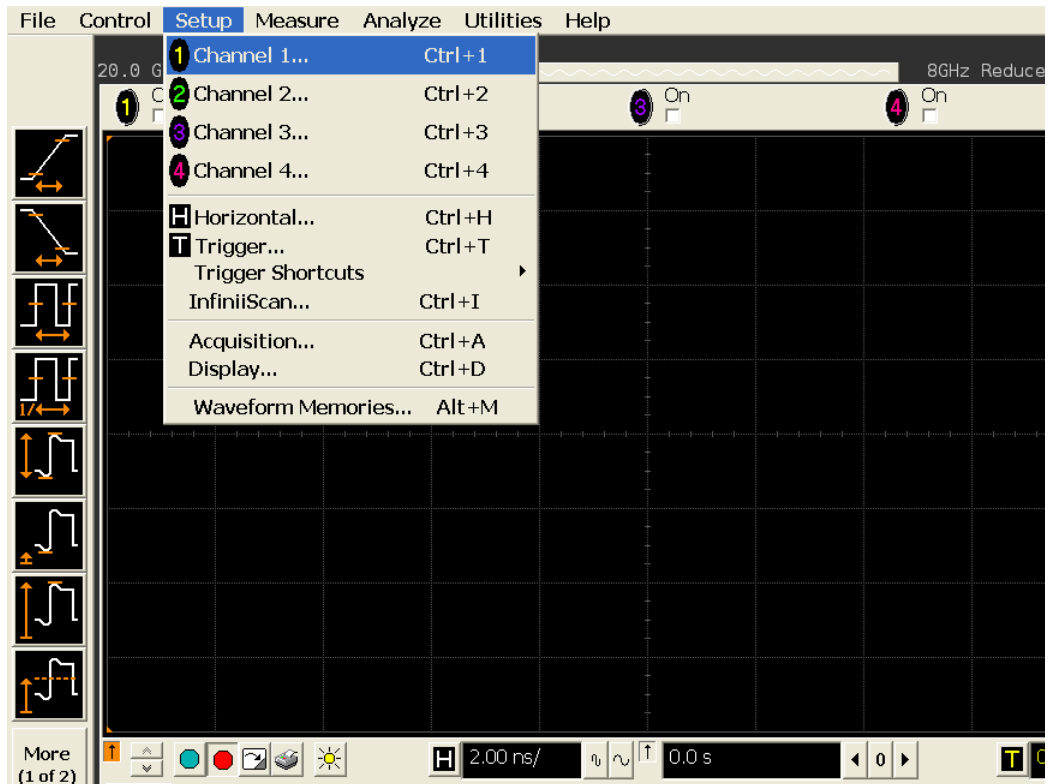

Figure 60 Channel Setup Window.

- 2 In the Channel Setup dialog box, select the Probes... button, as shown in Figure 61.

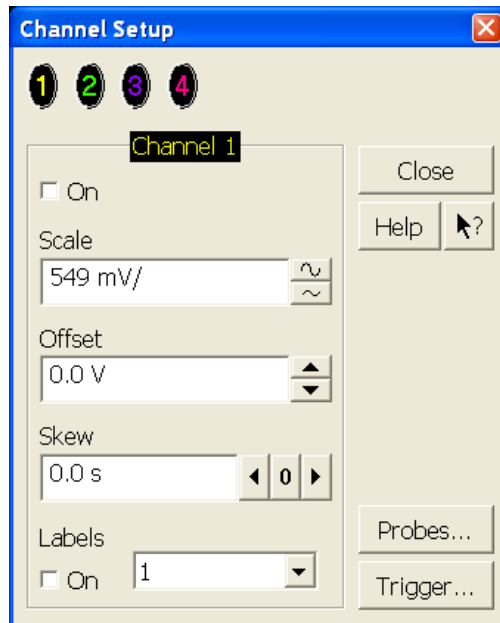

Figure 61 Channel Dialog Box

- 3 In the Probe Setup dialog box, select the Calibrate Probe... button.

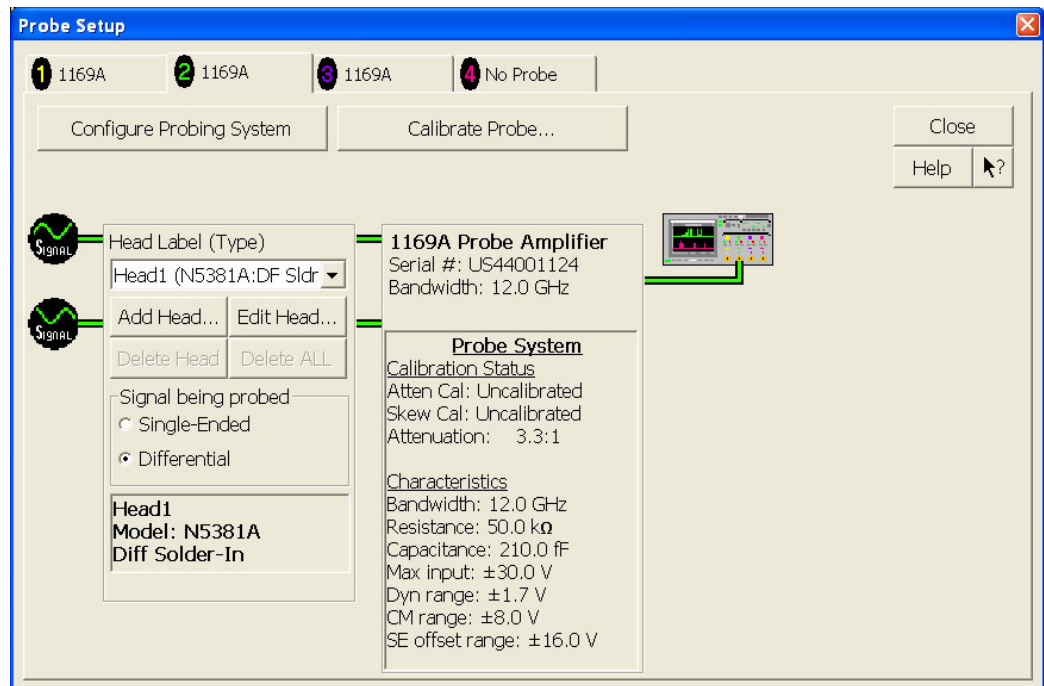

Figure 62 Probe Setup Window.

- 4 In the Probe Calibration dialog box, select the Calibrated Atten/Offset radio button.
- 5 Select the Start Atten/Offset Calibration... button and follow the on-screen instructions for the vertical calibration procedure.

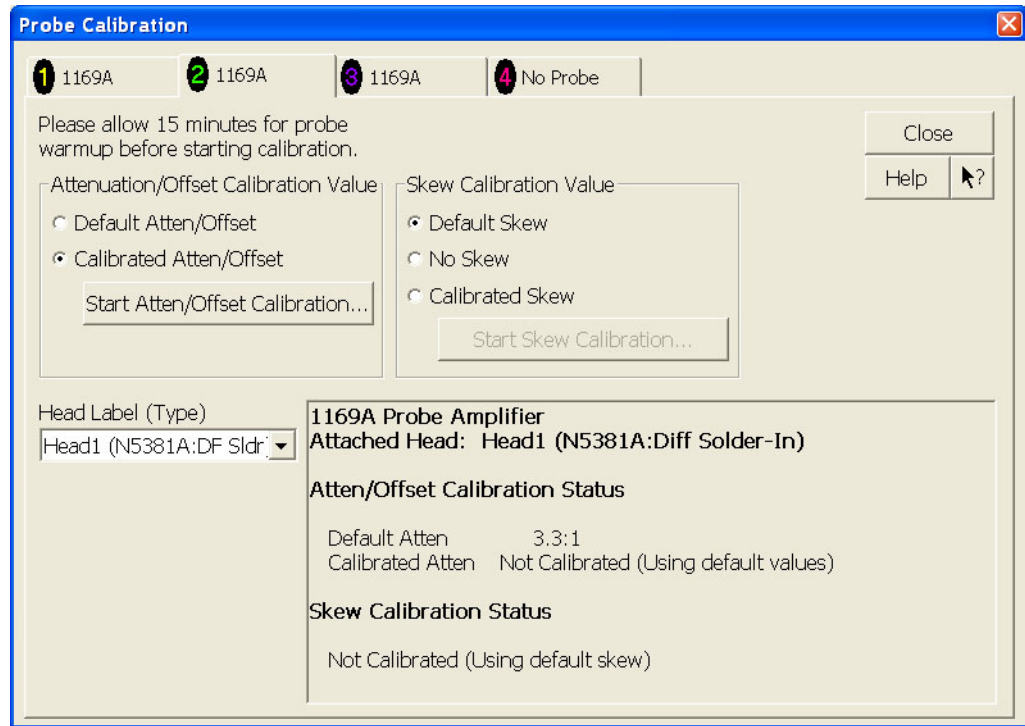

Figure 63 Probe Calibration Window.

- 6 Once the vertical calibration has successfully completed, select the Calibrated Skew... button.
- 7 Select the Start Skew Calibration... button and follow the on-screen instructions for the skew calibration.

At the end of each calibration, the oscilloscope will prompt you if the calibration was or was not successful.

Verifying the Probe Calibration

If you have successfully calibrated the probe, it is not necessary to perform this verification. However, if you want to verify that the probe was properly calibrated, the following procedure will help you verify the calibration.

The calibration procedure requires the following parts:

- BNC (male) to SMA (male) adaptor
- SMA (male) to BNC (female) adaptor
- BNC (male) to BNC (male) 12 inch cable such as the Keysight 8120-1838
- Keysight 54855-61620 calibration cable (Infiniium oscilloscopes with bandwidths of 6 GHz and greater only)
- Keysight 54855-67604 precision 3.5 mm adaptors (Infiniium oscilloscopes with bandwidths of 6 GHz and greater only)
- Deskew fixture

For the following procedure, refer to [Figure 64](#).

- 1 Connect BNC (male) to SMA (male) adaptor to the deskew fixture on the connector closest to the yellow pincher.
- 2 Connect the SMA (male) to BNC (female) to the connector farthest from the yellow pincher.
- 3 Connect the BNC (male) to BNC (male) cable to the BNC connector on the deskew fixture to one of the unused oscilloscope channels. For Infiniium oscilloscopes with bandwidths of 6 GHz and greater, use the 54855-61620 calibration cable and the two 54855-64604 precision 3.5 mm adaptors.
- 4 Connect the BNC side of the deskew fixture to the Aux Out BNC of the Infiniium oscilloscope.
- 5 Connect the probe to an oscilloscope channel.
- 6 To minimize the wear and tear on the probe head, it should be placed on a support to relieve the strain on the probe head cables.
- 7 Push down on the back side of the yellow pincher. Insert the probe head resistor lead underneath the center of the yellow pincher and over the center conductor of the deskew fixture. The negative probe head resistor lead or ground lead must be underneath the yellow pincher and over one of the outside copper conductors (ground) of the deskew fixture. Make sure that the probe head is approximately perpendicular to the deskew fixture.
- 8 Release the yellow pincher.
- 9 On the oscilloscope, press the autoscale button on the front panel.
- 10 Select Setup menu and choose the channel connected to the BNC cable from the pull-down menu.
- 11 Select the Probes... button.
- 12 Select the Configure Probe System button.
- 13 Select User Defined Probe from the pull-down menu.
- 14 Select the Calibrate Probe... button.
- 15 Select the Calibrated Skew radio button.
- 16 Once the skew calibration is completed, close all dialog boxes.

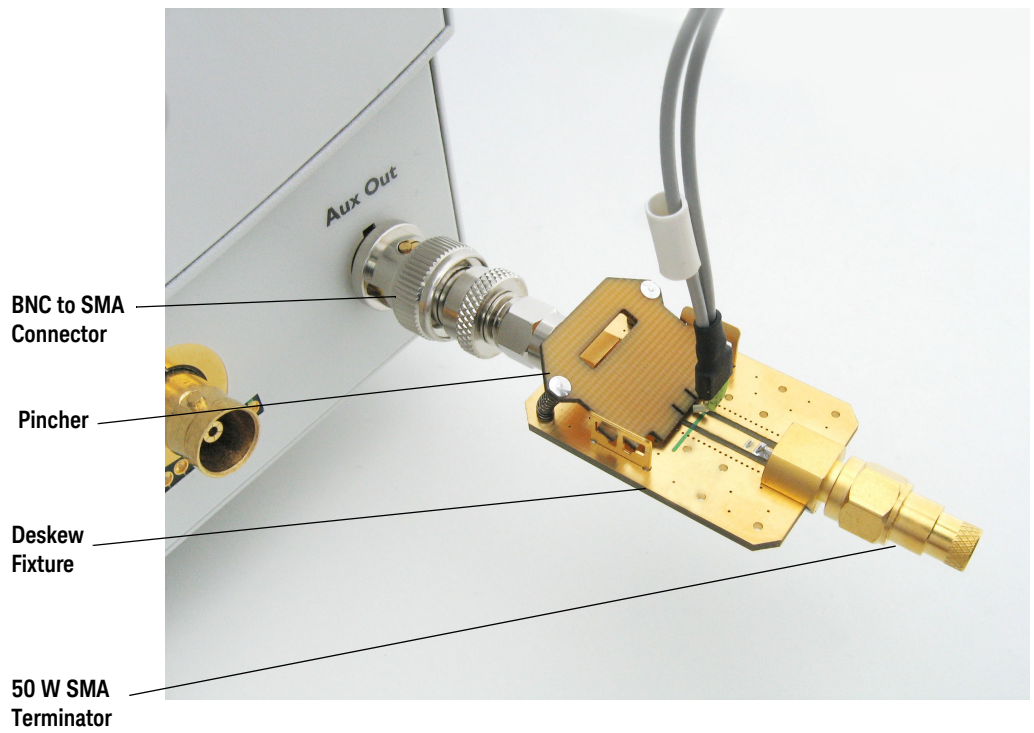

Figure 64 Probe Calibration Verification Connection Example

- 17 Select the Start Skew Calibration... button and follow the on-screen instructions.
- 18 Set the vertical scale for the displayed channels to 100 mV/div.
- 19 Set the horizontal range to 1.00 ns/div.
- 20 Set the horizontal position to approximately 3 ns.
- 21 Change the vertical position knobs of both channels until the waveforms overlap each other.
- 22 Select the Setup menu choose Acquisition... from the pull-down menu.
- 23 In the Acquisition Setup dialog box enable averaging. When you close the dialog box, you should see waveforms similar to that in [Figure 65](#).

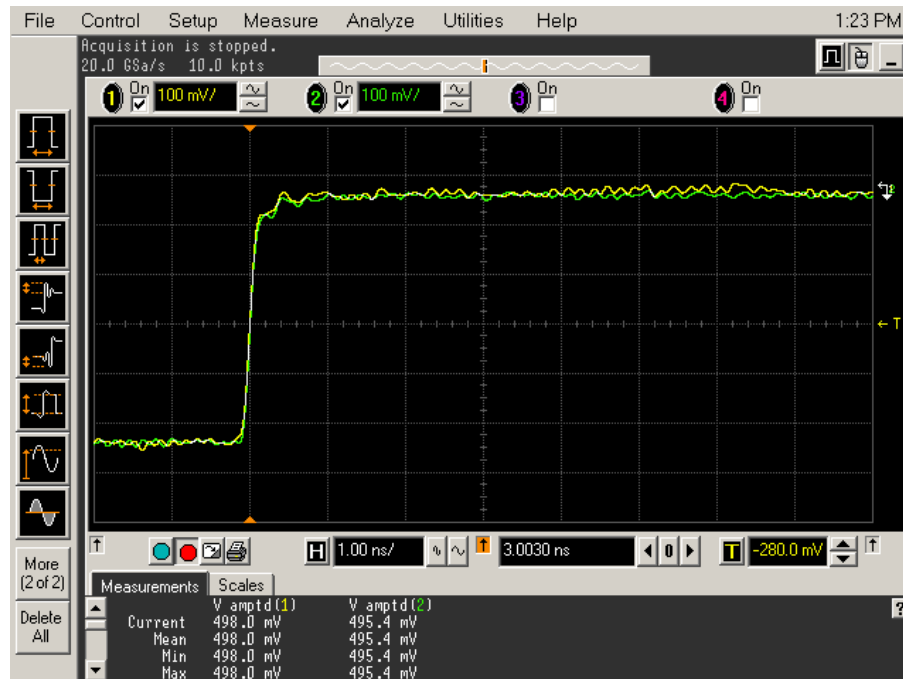

Figure 65 Calibration Probe Waveform Example

NOTE

Each probe is calibrated with the oscilloscope channel to which it is connected. Do not switch probes between channels or other oscilloscopes, or it will be necessary to calibrate them again. It is recommended that the probes be labeled with the channel on which they were calibrated.

14 InfiniiMax Probing



Figure 66 1134A InfiniiMax Probe Amplifier

Keysight recommends 116xA or 113xA probe amplifiers, which range from 3.5 GHz to 12 GHz.

Keysight also recommends the E2677A differential solder-in probe head. Other probe head options include N5381A InfiniiMax II 12 GHz differential solder-in probe head, N5382A InfiniiMax II 12 GHz differential browser, E2675A InfiniiMax differential browser probe head, N5425A InfiniiMax ZIF probe head and N5426A ZIF Tips.



Figure 67 E2677A / N5381A Differential Solder-in Probe Head

Table 65 Probe Head Characteristics (with 1134A probe amplifier)

Probe Head	Model Number	Differential Measurement (BW, input C, input R)	Single-Ended Measurement (BW, input C, input R)
Differential Solder-in	E2677A	7 GHz, 0.27 pF, 50 kOhm	7 GHz, 0.44 pF, 25 kOhm

Used with 1168A or 1169A probe amplifier, the E2677A differential solder-in probe head provides 10 GHz and 12 GHz bandwidth respectively.

15 Common Error Messages

Required Triggering Condition Not Met / 188
Software License Error / 190
Frequency Out of Range Error / 191
Missing Signal Error / 192
Missing Signal Error / 192
Invalid Pre/PostAmble Signal Error / 193

When performing DDR1 tests, error message dialog boxes can occur due to improper configuration settings. This section describes the common errors, causes and solution to the problem.

Required Triggering Condition Not Met

The following error message will appear when a time-out occurs. This error message indicates that the required triggering condition is not met. This is followed by test cancellation and aborting message. All pending tests will be cancelled.

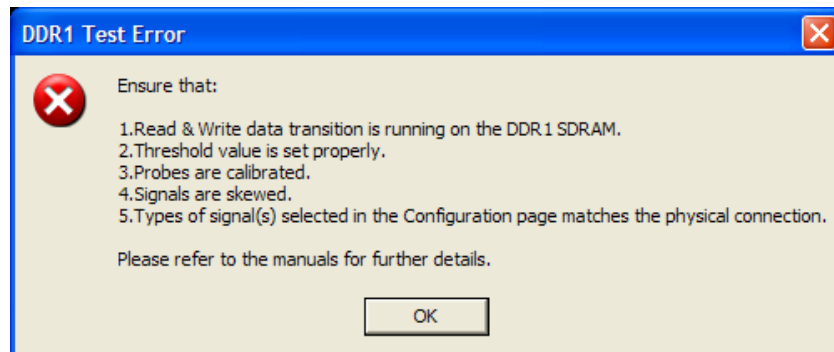

Figure 68 Required Trigger Condition Not Met Error Message



Figure 69 Cancel and Abort Test Message

These error dialog boxes appear when one of the following configuration errors is encountered.

- Required triggering condition is not met. For example, if the setup time condition in a triggering requirement, is not met within a certain time (approximately 10s), the time-out error will occur.
- Attempt to run the Electrical tests without first executing the RAM reliability test software on the DDR Device Under Test (DUT) system.
- Attempt to run the Electrical tests without providing any test signal to the oscilloscope.
- Threshold value is not properly set.
- Signals are not skewed.
- The type of signals selected in the Configuration page does not match the physical connection.

Ensure that:

- The RAM reliability test software is running to exercise the SDRAM. This ensures that there are Read and Write signals running on the SDRAM in order for the application to capture the signal.
- The threshold is properly set according to the actual signal performance. For example, if the maximum voltage of the DQ signal is 1.8V and the minimum voltage is 40mV, you must ensure that the upper and lower threshold value does not exceed the minimum and maximum limit, in order to trigger the signal. Scope will not be triggered if the upper threshold is set to be above 1.8V, since the maximum voltage on the actual signal is just 1.8V and below.

- The probes are properly calibrated and skewed. Ensure that correct probes are used and they are properly calibrated, so that it reflects the actual signal and is not over or under amplified. Similarly, ensure that the channels are properly soldered on the DDR1 module and ensure that the signals are not over skewed.
- The types of signals selected in the Configuration page matches the physical connection. For example, if Channel 1 is physically connected to the Clock signal, ensure that you select the same in the Configuration page.

Software License Error

When you load the N5413A DDR1 Compliance Test Application, it checks for the required software licenses. When one of the optional licenses is not detected, the application will limit the available test options and the Set Up tab will look similar to following screenshot.

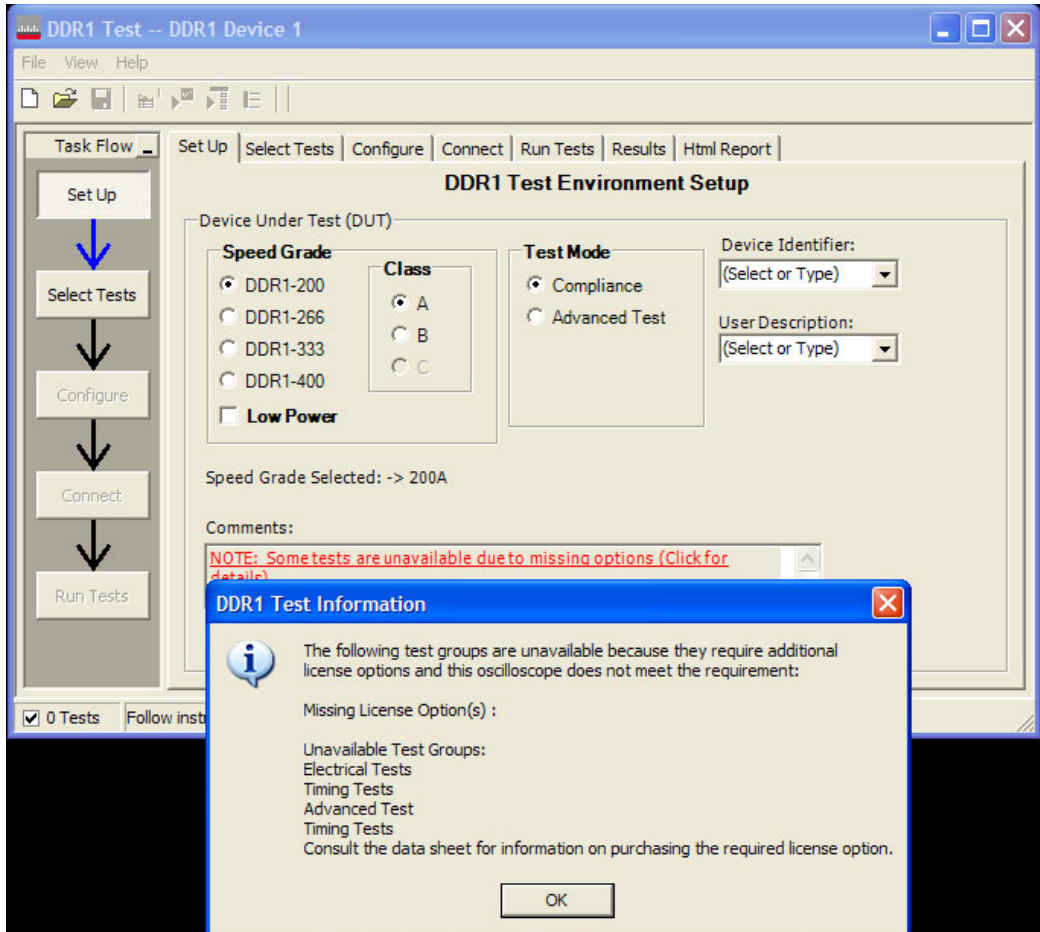

Figure 70 Software License Error

Ensure you have installed all required licenses before running the N5413A DDR1 Compliance Test Application.

Frequency Out of Range Error

You are allowed to type in the DUT data rate for the Advanced Debug Mode tests. However, if you enter an incorrect data strobe test signal frequency, the following error dialog box appears. For example, if the selected DDR1 speed grade option is DDR1-400, the expected frequency of the data strobe signal, DQS is 200MH (half of the data transfer rate). However, if the measured DQS frequency is out by +/-10% of the expected frequency value, exception will be thrown.

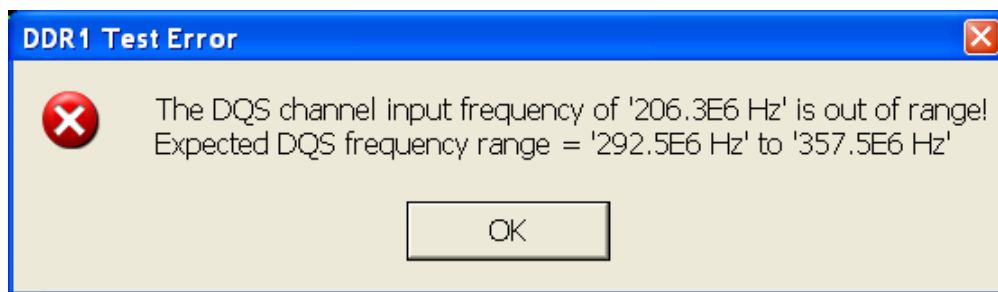

Figure 71 Frequency Out of Range Error

Type in the correct data rate, within the range, as mentioned in the error message box.

Missing Signal Error

This error occurs when the required signals are either not selected in the “Channel Setting” configuration or not connected to the oscilloscope. Ensure that correct channel is selected based on the signal that is physically present at the oscilloscope channel.

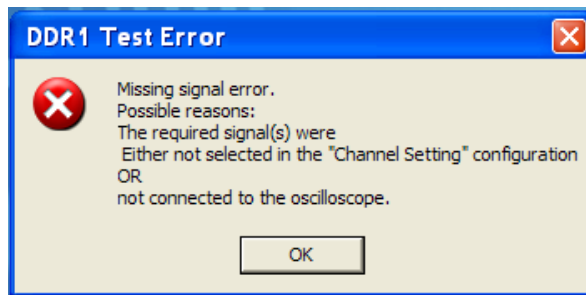

Figure 72 Missing Signal Error Message

Invalid Pre/PostAmble Signal Error

This error occurs during the multiple trial run if there is no significant voltage level transits when the driver is turned on or off during the preamble or postamble. You should verify the signals especially the DQS and DQ if they provide a valid preamble or postamble signal. If there is no significant voltage level transition when the driver is turned on or off during the pre-amble OR post-amble, the system will throw an exception to prompt user to verify the signal.

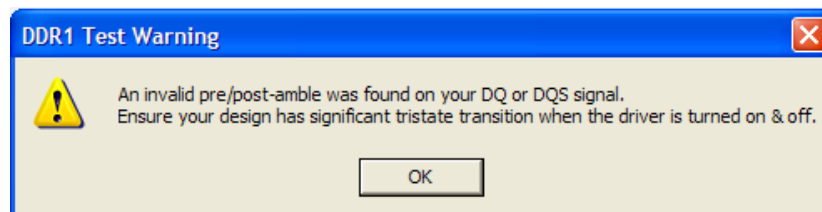

Figure 73 Invalid Pre/Post Amble Signal Error Message

You can disable this error message at the Configure tab. Turn the “Signal error message prompt” to the Disable mode. This will prevent the above error message being prompt during the multiple trial run.

Index

A

AC Differential Input Cross Point Voltage, [78](#)
AC Differential Input Voltage, [75](#)
Address and Control Input Hold Time, [147](#)
Address and Control Input Setup Time, [145](#)
Average Clock Period, [128](#)
Average High Pulse Width, [131](#)
Average Low Pulse Width, [131](#)

B

BNC shorting cap, [170](#)
BNC to SMA male adapter, [170](#)

C

calibrating the oscilloscope, [169](#)
calibration cable, [170](#)
Clock Period Jitter, [154](#)
Clock Timing (CT) Tests, [117](#)
Clock to Clock Period Jitter, [155](#)
computer motherboard system, [6](#)
configure, [28](#)
connect, [28](#)
Cumulative Error, [156](#)

D

Data Mask Timing (DMT) Tests, [133](#)
Data Strobe Timing (DST) Tests, [81](#)
differential browser, [6](#)
differential solder-in probe head, [6](#), [185](#)
DQ and DM Input Hold Time, [139](#)
DQ and DM Input Setup Time, [137](#)
DQ Low-Impedance Time from CK/CK#, [91](#)
DQ Out High Impedance Time From CK/CK#, [85](#), [87](#)
DQ/DQS Output Hold Time From DQS, [96](#)
DQS Falling Edge Hold Time from CK, [106](#)
DQS Falling Edge to CK Setup Time, [104](#)
DQS Input High Pulse Width, [100](#)
DQS Input Low Pulse Width, [102](#)

DQS Latching Transition to Associated Clock Edge, [98](#)
DQS Low-Impedance Time from CK/CK#, [89](#)
DQS Output Access Time from CK/CK#, [124](#)
DQS-DQ Skew for DQS and Associated DQ Signals, [94](#)

E

error messages, [187](#)

H

Half Period Jitter, [157](#)
High State Ringing Tests, [164](#)
HTML report, [28](#)

I

in this book, [7](#)
InfiniiScan software license, [6](#)
Input Signal Minimum Slew Rate (Falling), [38](#)
Input Signal Minimum Slew Rate (Rising), [35](#)
internal calibration, [171](#)

K

keyboard, [6](#), [170](#)

L

license key, installing, [23](#)
Low State Ringing Tests, [166](#)

M

Maximum AC Input Logic High, [41](#)
Maximum AC Output Logic High, [57](#)
Maximum DC Input Logic Low, [50](#)
Minimum AC Input Logic Low, [47](#)
Minimum AC Output Logic Low, [59](#)
Minimum DC Input Logic High, [44](#)
mouse, [6](#), [170](#)

O

over/undershoot tests, [61](#)

P

precision 3.5 mm BNC to SMA male adapter, [170](#)
probe calibration, [175](#)
Probing for Advanced Debug Mode High-Low State Ringing Tests, [160](#)
Probing for Clock Timing Tests, [118](#)
Probing for Command and Address Timing Tests, [142](#)
Probing for Data Mask Timing Tests, [134](#)
Probing for Data Strobe Timing Tests, [82](#)
Probing for Differential Signals AC Input Parameters Tests, [72](#)
Probing for Measurement Clock Tests, [150](#)
Probing for Overshoot/Undershoot Tests, [62](#)
Probing for Single-Ended Signals AC Input Parameters Tests, [32](#)
Probing for Single-Ended Signals AC Output Parameters Tests, [54](#)

R

RAM reliability test software, [6](#)
Read Postamble, [114](#)
Read Preamble, [112](#)
report, [28](#)
required equipment and software, [6](#)
required equipment for calibration, [170](#)
results, [28](#)
run tests, [28](#)

S

select tests, [28](#)
SlewF, [38](#)
SlewR, [35](#)
start the DDR1 Compliance Test Application, [27](#)

T

tAC, [121](#)
tCH(avg), [130](#)
tCK(avg), [128](#)
tCL(avg), [131](#)
tDH(base), [139](#)
tDQSK, [121](#)

tDQSH, 100
tDQSL, 102
tDQSQ, 94
tDQSS, 98
tDS(base), 137
tDSH, 106
tDSS, 104
tERR(n per), 156
tHZ(DQ), 85, 87
tHZ(DQS), 87
tIH(base), 147
tIS(base), 145
tJIT(cc), 155
tJIT(duty), 157
tJIT(per), 154
tLZ(DQ), 91
tLZ(DQS), 89
tQH, 96
tRPRE, 112
tRPST, 114
tWPRE, 110
tWPST, 108

V

VID(AC), 75
VIH(ac), 41
VIH(dc), 44
VIL(ac), 47
VIL(dc), 50
VIX(ac), 78
VOH(AC), 57
VOH(DC), 59
VOL(AC), 59

W

Write Postamble, 108
Write Preamble, 110

Z

ZIF probe, 6
ZIF tips, 6