

---

# E4980A/E4980AL Precision LCR Meter

# Notices

© Keysight Technologies  
2006–2023

No part of this manual may be reproduced in any form or by any means (including electronic storage and retrieval or translation into a foreign language) without prior agreement and written consent from Keysight Technologies, Inc. as governed by United States and international copyright laws.

## Trademark Acknowledgments

## Manual Part Number

E4980-90120

## Edition

Edition 9, March 2023

Printed in Malaysia

Published by:

**Keysight Technologies International  
Japan G.K.**  
1-3-3 Higashikawasaki-cho  
Chuo-ku  
Kobe-shi, Hyogo, Japan

## Warranty

THE MATERIAL CONTAINED IN THIS DOCUMENT IS PROVIDED “AS IS,” AND IS SUBJECT TO BEING CHANGED, WITHOUT NOTICE, IN FUTURE EDITIONS. FURTHER, TO THE MAXIMUM EXTENT PERMITTED BY APPLICABLE LAW, KEYSIGHT DISCLAIMS ALL WARRANTIES, EITHER EXPRESS OR IMPLIED WITH REGARD TO THIS MANUAL AND ANY INFORMATION CONTAINED HEREIN, INCLUDING BUT NOT LIMITED TO THE IMPLIED WARRANTIES OF MERCHANTABILITY AND FITNESS FOR A PARTICULAR PURPOSE. KEYSIGHT SHALL NOT BE LIABLE FOR ERRORS OR FOR INCIDENTAL OR CONSEQUENTIAL DAMAGES IN CONNECTION WITH THE FURNISHING, USE, OR PERFORMANCE OF THIS DOCUMENT OR ANY INFORMATION CONTAINED HEREIN. SHOULD KEYSIGHT AND THE USER HAVE A SEPARATE WRITTEN AGREEMENT WITH WARRANTY TERMS

COVERING THE MATERIAL IN THIS DOCUMENT THAT CONFLICT WITH THESE TERMS, THE WARRANTY TERMS IN THE SEPARATE AGREEMENT WILL CONTROL.

## Technology Licenses

The hardware and/or software described in this document are furnished under a license and may be used or copied only in accordance with the terms of such license.

## Declaration of Conformity

Declarations of Conformity for this product and for other Keysight products may be downloaded from the Web. Go to <http://www.keysight.com/go/conformity>. You can then search by product number to find the latest Declaration of Conformity.

## U.S. Government Rights

The Software is “commercial computer software,” as defined by Federal Acquisition Regulation (“FAR”) 2.101. Pursuant to FAR 2.212 and 27.405-3 and Department of Defense FAR Supplement (“DFARS”) 227.7202, the U.S. government acquires commercial computer software under the same terms by which the software is customarily provided to the public. Accordingly, Keysight provides the Software to U.S. government customers under its standard commercial license, which is embodied in its End User License Agreement (EULA), a copy of which can be found at

<http://www.keysight.com/find/sweula> The license set forth in the EULA represents the exclusive authority by which the U.S. government may use, modify, distribute, or disclose the Software. The EULA and the license set forth therein, does not require or permit, among other things, that Keysight: (1) Furnish technical information related to commercial computer software or commercial computer software documentation that is not customarily provided to the public; or (2) Relinquish to, or otherwise provide, the government rights in excess of these rights customarily provided to the public to use, modify, reproduce, release,

perform, display, or disclose commercial computer software or commercial computer software documentation. No additional government requirements beyond those set forth in the EULA shall apply, except to the extent that those terms, rights, or licenses are explicitly required from all providers of commercial computer software pursuant to the FAR and the DFARS and are set forth specifically in writing elsewhere in the EULA. Keysight shall be under no obligation to update, revise or otherwise modify the Software. With respect to any technical data as defined by FAR 2.101, pursuant to FAR 12.211 and 27.404.2 and DFARS 227.7102, the U.S. government acquires no greater than Limited Rights as defined in FAR 27.401 or DFARS 227.7103-5 (c), as applicable in any technical data.

## Safety Notices

### CAUTION

A **CAUTION** notice denotes a hazard. It calls attention to an operating procedure, practice, or the like that, if not correctly performed or adhered to, could result in damage to the product or loss of important data. Do not proceed beyond a CAUTION notice until the indicated conditions are fully understood and met.

### WARNING

A **WARNING** notice denotes a hazard. It calls attention to an operating procedure, practice, or the like that, if not correctly performed or adhered to, could result in personal injury or death. Do not proceed beyond a WARNING notice until the indicated conditions are fully understood and met.

Service Guide

## Caution



Do not exceed the operating input power, voltage, and current level and signal type appropriate for the instrument being used, refer to your instrument's Function Reference.



Electrostatic discharge (ESD) can damage the highly sensitive microcircuits in your instrument. ESD damage is most likely to occur as the test fixtures are being connected or disconnected. Protect them from ESD damage by wearing a grounding strap that provides a high resistance path to ground. Alternatively, ground yourself to discharge any static charge built-up by touching the outer shell of any grounded instrument chassis before touching the test port connectors.

## Safety Summary

When you notice any of the unusual conditions listed below, immediately terminate operation and disconnect the power cable.

Contact your local Keysight Technologies sales representative or authorized service company for repair of the instrument. If you continue to operate without repairing the instrument, there is a potential fire or shock hazard to the operator.

- Instrument operates abnormally.
- Instrument emits abnormal noise, smell, smoke or a spark-like light during operation.
- Instrument generates high temperature or electrical shock during operation.
- Power cable, plug, or receptacle on instrument is damaged.
- Foreign substance or liquid has fallen into the instrument.

## Manufacturer's Declaration

### **Herstellerbescheinigung**

GERA- USCHEMISSION

LpA < 70 dB

am Arbeitsplatz

normaler Betrieb

nach DIN 45635 T. 19

### **Manufacturer's Declaration**

ACOUSTIC NOISE EMISSION

LpA < 70 dB

operator position

normal operation

per ISO 7779

## Regulatory Compliance Information

This product complies with the essential requirements of the following applicable European Directives, and carries the CE marking accordingly:

- The Low Voltage Directive 2006/95/EC
- The EMC Directive 2004/108/EEC

To obtain Declaration of Conformity, please contact your local Keysight Technologies sales office, agent or distributor.

## Safety Notice Supplement

- This equipment complies with EN/IEC61010-1:2001.
- This equipment is of MEASUREMENT CATEGORY I (CAT I). Do not use for CAT II, III, or IV.
- Do not connect the measuring terminals to mains.
- This equipment is a POLLUTION DEGREE 2, INDOOR USE product.
- This equipment is tested in stand-alone condition and in combination with the accessories supplied by Keysight Technologies against the requirement of the standards described in the Declaration of Conformity. If it is used as a system component, compliance of related regulations and safety requirements are to be confirmed by the builder of the system.

## General Safety Precautions

The following general safety precautions must be observed during all phases of operation, service, and repair of this instrument. Failure to comply with these precautions or with specific WARNINGS elsewhere in this manual may impair the protection provided by the equipment. Such noncompliance would also violate safety standards of design, manufacture, and intended use of the instrument. Keysight Technologies assumes no liability for the customer's failure to comply with these precautions.

### NOTE

The E4980A/E4980AL complies with INSTALLATION CATEGORY II as well as POLLUTION DEGREE 2 in IEC61010-1. The E5061B is an INDOOR USE product.

---

### NOTE

The LEDs in the E4980A/E4980AL are Class 1 in accordance with IEC60825-1, CLASS 1 LED PRODUCT.

---

- Ground the Instrument  
To avoid electric shock, the instrument chassis and cabinet must be grounded with the supplied power cable's grounding prong.
- Do NOT Operate in an Explosive Atmosphere  
Do not operate the instrument in the presence of inflammable gases or fumes. Operation of any electrical instrument in such an environment clearly constitutes a safety hazard.
- Keep Away from Live Circuits  
Operators must not remove instrument covers. Component replacement and internal adjustments must be made by qualified maintenance personnel. Do not replace components with the power cable connected. Under certain conditions, dangerous voltage levels may remain even after the power cable has been disconnected. To avoid injuries, always disconnect the power and discharge circuits before touching them.
- DO NOT Service or Adjust the Instrument Alone  
Do not attempt internal service or adjustment unless another person, capable of rendering first aid and resuscitation, is present.
- Do NOT Substitute Parts or Modify the Instrument  
To avoid the danger of introducing additional hazards, do not install substitute parts or perform unauthorized modifications to the instrument. Return the instrument to a Keysight Technologies Sales and Service Office for service and repair to ensure that safety features are maintained in operational condition.

- Dangerous Procedure Warnings

Warnings, such as the example below, precede potentially dangerous procedures throughout this manual. Instructions contained in the warnings must be followed.

**WARNING**

**Dangerous voltage levels, capable of causing death, are present in this instrument. Use extreme caution when handling, testing, and adjusting this instrument.**

---

## Safety Symbols

General definitions of safety symbols used on the instrument or in manuals are listed below.



Instruction Manual symbol: the product is marked with this symbol when it is necessary for the user to refer to the instrument manual.



Alternating current.



Direct current.



On (Supply).



Off (Supply).



A chassis terminal; a connection to the instrument's chassis, which includes all exposed metal structure.



Standby.

## Certification

Keysight Technologies certifies that this product met its published specifications at the time of shipment from the factory. Keysight Technologies further certifies that its calibration measurements are traceable to the United States National Institute of Standards and Technology, to the extent allowed by the Institution's calibration facility or by the calibration facilities of other International Standards Organization members.

## Documentation Warranty

The material contained in this document is provided “as is,” and is subject to being changed, without notice, in future editions. Further, to the maximum extent permitted by applicable law, Keysight disclaims all warranties, either express or implied with regard to this manual and any information contained herein, including but not limited to the implied warranties of merchantability and fitness for a particular purpose. Keysight shall not be liable for errors or for incidental or consequential damages in connection with the furnishing, use, or performance of this document or any information contained herein. Should Keysight and the user have a separate written agreement with warranty terms covering the material in this document that conflict with these terms, the warranty terms in the separate agreement will control.

## Exclusive Remedies

The remedies provided herein are Buyer’s sole and exclusive remedies. Keysight Technologies shall not be liable for any direct, indirect, special, incidental, or consequential damages, whether based on contract, tort, or any other legal theory.

## Assistance

Product maintenance agreements and other customer assistance agreements are available for Keysight Technologies products.

For any assistance, contact your nearest Keysight Technologies Sales and Service Office. Addresses are provided at the back of this manual.



Caution  
Manuals for E4980A/E4980AL

## Manuals for E4980A/E4980AL

Keysight provides the following three manuals for E4980A/E4980AL. The latest version of all documentations can be downloaded from <http://www.keysight.com/manual/e4980a>.

### Installation Guide

The installation guide (this manual) provides start up setup information when you use the E4980A/E4980AL for the first time and troubleshooting information when the Windows cannot be boot up. See this manual first when you use the E4980A/E4980AL for the first time.

### Service Guide

The service guide (this manual) provides troubleshooting information when operational problems are encountered on the E4980A/E4980AL. See this manual when you need to troubleshoot the E4980A/E4980AL.

Caution  
Manuals for E4980A/E4980AL

Table of Contents

Caution . . . . .	3
Safety Summary . . . . .	3
Manufacturer’s Declaration . . . . .	4
Regulatory Compliance Information . . . . .	4
Safety Notice Supplement . . . . .	5
General Safety Precautions . . . . .	6
Safety Symbols . . . . .	7
Certification . . . . .	7
Documentation Warranty . . . . .	8
Exclusive Remedies . . . . .	8
Assistance . . . . .	8
Manuals for E4980A/E4980AL . . . . .	9
Installation Guide . . . . .	9
Service Guide . . . . .	9
<b>1. General Information</b>	
Organization of Service Guide . . . . .	17
Instruments Covered by This Manual . . . . .	19
Required Equipment . . . . .	20
<b>2. Performance Test</b>	
Introduction . . . . .	21
Test Equipment Required . . . . .	22
Individual Test Description . . . . .	23
1. Frequency Accuracy Test . . . . .	23
2. DC Source Level Accuracy Test . . . . .	23
3. DC Bias Level Accuracy Test . . . . .	23
4. DC Bias V Level Monitor Accuracy Test . . . . .	23
5. DC Bias I Level Monitor Accuracy Test . . . . .	23
6. AC Signal Level Monitor Accuracy Test . . . . .	23
7. AC Signal Level Accuracy Test . . . . .	24
8. Impedance Measurement Accuracy Test . . . . .	24
9. DCR Measurement Accuracy Test . . . . .	24
<b>3. Adjustment</b>	
Safety Considerations . . . . .	25
Warm-up for Adjustment . . . . .	25
Required Equipment . . . . .	25

## Contents

Required Adjustment after Replacing Assembly . . . . .	26
Writing ID. . . . .	26
Write Null Phase Track Default Data . . . . .	26
Null DC Offset Adjustment . . . . .	26
Null ADC DC Offset Adjustment . . . . .	26
ADC Linearity Adjustment . . . . .	26
DC Bias Adjustment . . . . .	27
DC Level V Monitor Adjustment . . . . .	27
DC Level I Monitor Adjustment . . . . .	27
DC Source Adjustment . . . . .	27
DCR Adjustment . . . . .	27
Impedance Adjustment . . . . .	27
AC Level Monitor Adjustment . . . . .	27
OSC Level Adjustment . . . . .	27
<b>4. Troubleshooting</b>	
Introduction . . . . .	29
To Troubleshoot the Instrument . . . . .	30
Primary Trouble Isolation . . . . .	30
Power On Sequence Troubleshooting . . . . .	32
Check the Line Voltage and Fuse . . . . .	32
Check the Power Supply Unit Output . . . . .	32
Check booting process . . . . .	35
Troubleshooting Using Service Function . . . . .	36
Power On Test . . . . .	36
Contents of the power on test results . . . . .	36
Self Test . . . . .	36
SERVICE Page . . . . .	39
Power On Test / Self Test Failure Troubleshooting . . . . .	43
Function Specific Troubleshooting . . . . .	47
To Check the Front Panel . . . . .	48
To Check the LCD . . . . .	48
To Check the Front USB port . . . . .	49
To Check the External Trigger Input . . . . .	49
To Check the LAN . . . . .	50
To Check the GPIB . . . . .	52
To Check the USB (USBTMC) Interface Card . . . . .	52
To Check the Handler Interface Function (Option 201 only) . . . . .	52
To Check the Scanner Interface Function (Option 301 only) . . . . .	57
To Check the Bias Current Interface Function (Option 002 only) . . . . .	60
Performance test failure troubleshooting . . . . .	65

Recommended adjustment for performance test failure . . . . .	65
Adjustment failure troubleshooting . . . . .	66
Performance test failure troubleshooting . . . . .	67
<b>5. Replaceable Parts</b>	
Replaceable Parts . . . . .	69
<b>6. Replacement Procedure</b>	
Replacing an Assembly . . . . .	71
Required Tools . . . . .	72
3/4 Rack Module Top Replacement . . . . .	73
Tools Required . . . . .	73
Removal Procedure . . . . .	73
Replacement Procedure . . . . .	73
A3 Analog Daughter Board Replacement . . . . .	77
Tools Required . . . . .	77
Removal Procedure . . . . .	77
Replacement Procedure . . . . .	77
A2 Analog Board Replacement . . . . .	79
Tools Required . . . . .	79
Removal Procedure . . . . .	79
Replacement Procedure . . . . .	79
Front Panel Assembly Removal . . . . .	81
Tools required . . . . .	81
Removal Procedure . . . . .	81
Replacement Procedure . . . . .	81
Option Interface Replacement . . . . .	82
Tools Required . . . . .	82
Removal Procedure . . . . .	82
Replacement Procedure . . . . .	82
PPMC PCA Replacement . . . . .	84
Tools Required . . . . .	84
Removal Procedure . . . . .	84
Replacement Procedure . . . . .	84
A1 Mother Board Replacement . . . . .	86
Tools Required . . . . .	86
Removal Procedure . . . . .	86
Replacement Procedure . . . . .	86
Power Supply Assembly Replacement . . . . .	88
Tools Required . . . . .	88
Removal Procedure . . . . .	88

## Contents

Replacement Procedure . . . . .	89
Base Plate Replacement . . . . .	91
Tools Required . . . . .	91
Removal Procedure . . . . .	91
Replacement Procedure . . . . .	92
Rear Panel Assembly Replacement . . . . .	94
Tools Required . . . . .	94
Removal Procedure . . . . .	94
Replacement Procedure . . . . .	95
FAN Assembly Replacement . . . . .	96
Tools Required . . . . .	96
Removal Procedure . . . . .	96
Replacement Procedure . . . . .	96
GPIB Cable Replacement . . . . .	98
Tools Required . . . . .	98
Removal Procedure . . . . .	98
Replacement Procedure . . . . .	98
Power Inlet Assembly Replacement . . . . .	100
Tools Required . . . . .	100
Removal Procedure . . . . .	100
Replacement Procedure . . . . .	100
PCA E4980 USB Replacement . . . . .	102
Tools Required . . . . .	102
Removal Procedure . . . . .	102
Replacement Procedure . . . . .	102
Binding Post Sgl Replacement . . . . .	103
Tools Required . . . . .	103
Removal Procedure . . . . .	103
Replacement Procedure . . . . .	103
Inverter Replacement . . . . .	105
Tools Required . . . . .	105
Removal Procedure . . . . .	105
Replacement Procedure . . . . .	105
Front Panel, Key Pad, and Key Flex Circuit Replacement. . . . .	107
Tools Required . . . . .	107
Removal Procedure . . . . .	107
Replacement Procedure . . . . .	107
Display Interface Replacement . . . . .	109
Tools Required . . . . .	109
Removal Procedure . . . . .	109
Replacement Procedure . . . . .	109

<b>7. Post-Repair Procedures</b>	
Post-Repair Procedures . . . . .	111
<b>A.Manual Changes</b>	
Manual Changes. . . . .	115
<b>B.Firmware Update</b>	
Update the E4980A/ E4980AL firmware using USB/GPIB interface. . . . .	117
Required Equipment. . . . .	117
How to update E4980A/ E4980AL firmware using USB/GPIB interface. . . . .	117
Update the E4980A/ E4980AL firmware using USB cable . . . . .	119
Required Equipment. . . . .	119
How to update E4980A/ E4980AL firmware using USB cable . . . . .	119
<b>C.Power Requirement</b>	
Replacing Fuse . . . . .	121
Fuse Selection . . . . .	121
Setting up the fuse. . . . .	121
Power Requirements. . . . .	122
Power Cable . . . . .	122
<b>D.Error Messages</b>	
Error Messages. . . . .	123
A . . . . .	123
B . . . . .	123
C . . . . .	124
D . . . . .	124
E . . . . .	125
F . . . . .	126
G . . . . .	126
H . . . . .	127
I . . . . .	127
M . . . . .	128
N . . . . .	128
O . . . . .	128
P . . . . .	129
Q . . . . .	129
R . . . . .	130
S . . . . .	130
T . . . . .	130
U . . . . .	131

## Contents

V.....	131
Warning Message .....	132
Numeric.....	132
A.....	132
C.....	132
I.....	132
S.....	133



# 1 General Information

This Service Guide is a guide to servicing the E4980A & E4980AL 20Hz to 300kHz/ 500kHz/ 1MHz/ 2MHz Precision LCR Meter. The Service Guide provides information about performance test, adjustment, troubleshooting, and repairing the instrument.

## Organization of Service Guide

Tabs are used to divide the major chapter and appendix of this manual. The contents of each chapter and appendix in this manual as follows.

- **Chapter 1, “General Information.”**

This Service Guide is a guide to servicing the E4980A & E4980AL 20Hz to 300kHz/ 500kHz/ 1MHz/ 2MHz Precision LCR Meter. The Service Guide provides information about performance test, adjustment, troubleshooting, and repairing the instrument.

- **Chapter 2, “Performance Test.”**

This chapter provides the outline of the E4980A/ E4980AL performance tests.

- **Chapter 3, “Adjustment.”**

This chapter provides the adjustment information for the E4980A/ E4980AL to ensure that it is within its specifications. The adjustment must be performed Keysight’s qualified service personnel. If you need the adjustment for your E4980A/ E4980AL, it should be sent to the nearest Keysight Technologies service office.

- **Chapter 4, “Troubleshooting.”**

This chapter provides the procedure to isolate a faulty assembly in the E4980A/ E4980AL.

- **Chapter 5, “Replaceable Parts.”**

This chapter contains information for ordering replacement parts for the E4980A/ E4980AL.

- **Chapter 6, “Replacement Procedure.”**

This chapter provides procedure for removing and replacing the major assemblies in the E4980A/ E4980AL.

- **Chapter 7, “Post-Repair Procedures.”**

This chapter lists the procedures required to verify the E4980A/ E4980AL operation after an assembly is replaced with a new one.

- **Appendix A , “Manual Changes,”**

This appendix contains the information required to adapt this manual to versions or configurations of the E4980A/ E4980AL manufactured earlier than the current printing date of this manual. The information in this manual applies directly to E4980A/ E4980AL units with the serial number that is printed on the title page of this manual.

- **Appendix B , “Firmware Update,”**

This appendix describes how to update the E4980A/ E4980AL firmware. When you want to update the E4980A/ E4980AL firmware, refer to this appendix.

- **Appendix C , “Power Requirement,”**

- **Appendix D , “Error Messages,”**

The Keysight E4980A/ E4980AL provides error messages to indicate its operating status. This appendix describes the error messages of the E4980A/ E4980AL in alphabetical order.

## Instruments Covered by This Manual

The ten-character serial number is printed on the serial number label on the rear panel.

An instrument manufactured after the printing date of this manual may have serial number prefix that is not listed on the title page. This unlisted serial number prefix indicates the instrument is different from those described in this manual. The manual for this new instrument may be accompanied by a yellow Manual Changes supplement or have a different manual part number. This sheet contains “change information” that explains how to adapt the manual to the newer instrument.

In addition to change information, the supplement may contain information for correcting errors (Errata) in the manual. To keep this manual as current and accurate as possible, Keysight Technologies recommends that you periodically request the latest Manual Changes supplement. The supplement for this manual is identified by this manual’s printing data and is available from Keysight Technologies. If the serial prefix or number of an instrument is lower than that on the title page of this manual, see Appendix A, Manual Changes. For information concerning a serial number prefix that is not listed on the title page or in the Manual Changes supplement, contact the nearest Keysight Technologies office.

## Required Equipment

**Table 1-1** lists the recommended equipment for performance test, adjustment and troubleshooting for E4980A/ E4980AL.

**Table 1-1 Recommended Test Equipment**

Equipment	Critical Specifications	Recommended Model	Qty.	Use <sup>1</sup>
Frequency Counter	Frequency Range: 1 MHz Time Base Error < 50 ppm/year	Keysight 53181A	1	P
Digital Multimeter	No Substitute	Keysight 3458A	1	P,A
Standard Capacitors Set	No Substitute	16380A	1	P,A
Standard Capacitors Set	No Substitute	16380C with option 001	1	P
Four Terminal Pair Standard Resistor Set	No Substitute	Keysight 42030A	1	P,A
4TP Open Termination	No Substitute	Keysight 42090A	1	P,A
4TP Short Termination	No Substitute	Keysight 42091A	1	P,A
Test Leads (BNC), 1 m	No Substitute	Keysight 16048A	1	P,A
Test Leads (BNC), 2 m	No Substitute	Keysight 16048D	1	P,A
Test Leads (BNC), 4 m	No Substitute	Keysight 16048E	1	P,A
DC Power Supply	+ 5V, 0.1A	Keysight E3610A	1	T
Handler Simulator	No Substitute	p/n 04278-65001	1	T
Scanner Simulator	No Substitute	p/n 04278-65301	1	T
Bias Interface Simulator	No Substitute	p/n 42841-65001	1	T
Bias Interface Cable	GP-IO Cable	p/n 42841-61640	1	T
Interface Box	No Substitute	p/n 04294-61002	1	P,A
Cables	BNC(m)-BNC(m) Cable, 122 cm	p/n 8120-1840	1	P,A
Adapter	BNC(f)-BNC(f) Adapter	p/n 1250-1830	4	P,A
	Dual Banana-BNC(f) Adapter	p/n 1251-2277	1	P,A

**1. P:Performance Test A:Adjustment T:Troubleshooting**

## 2 Performance Test

This chapter provides the outline of the E4980A/ E4980AL performance tests.

### Introduction

This chapter provides the performance tests outline for Keysight E4980A/ E4980AL. The performance test names are listed in **Table 2-1**. The test descriptions are described sequentially in the following pages.

**NOTE**

Allow the analyzer to warm up for at least 30 minutes before you execute any of the performance tests.

Perform all performance tests in an ambient temperature of  $23 \pm 5$  °C

**NOTE**

The performance tests should be performed periodically. The recommended test interval is 12 months.

The test interval depends on maintenance and the environmental conditions under which the instrument is used. You may find that the interval could be shortened or lengthened; however, such a decision should be based on substantial quantitative data.

Table 2-1

List of the E4980A/ E4980AL performance tests

Para.	Title
1	Frequency Accuracy Test
2	DC Source Level Accuracy Test
3	DC Bias Level Accuracy Test
4	DC bias V Level Monitor Accuracy Test
5	DC bias I Level Monitor Accuracy Test
6	AC Signal Level Monitor Accuracy Test
7	AC Signal Level Accuracy Test

Table 2-1

List of the E4980A/ E4980AL performance tests

Para.	Title
8	Impedance Measurement Accuracy Test
9	DCR Measurement Accuracy Test

#### Test Equipment Required

The required equipment for the performance test is listed in [Table 1-1](#). Use only calibrated equipment when doing the performance test.

## Individual Test Description

### 1. Frequency Accuracy Test

#### **Description**

This test checks the frequency accuracy of the E4980A/ E4980AL test signal. The frequency accuracy is checked at 1MHz with a frequency counter. Since the E4980A/ AL employs a Direct Digital Synthesizer for the signal source, the frequency accuracy test at this frequency point can verify the accuracy for the entire frequency range.

### 2. DC Source Level Accuracy Test

#### **Description**

This test checks the DC source level accuracy of the E4980A/ E4980AL DC source port output signal.

### 3. DC Bias Level Accuracy Test

#### **Description**

This test checks the DC bias level accuracy of the E4980A/ E4980AL DC bias signal.

### 4. DC Bias V Level Monitor Accuracy Test

#### **Description**

This test checks the DC bias V level monitor accuracy of the E4980A/ E4980AL. (Option: 001 only)

### 5. DC Bias I Level Monitor Accuracy Test

#### **Description**

This test checks the DC bias I level monitor accuracy of the E4980A/ E4980AL. (Option: 001 only)

### 6. AC Signal Level Monitor Accuracy Test

#### **Description**

This test checks the AC signal level monitor accuracy of the E4980A/ E4980AL.

## 7. AC Signal Level Accuracy Test

### **Description**

This test checks the AC signal level accuracy of the E4980A/ E4980AL output signal.

## 8. Impedance Measurement Accuracy Test

### **Description**

This test checks the impedance measurement accuracy of the E4980A/ E4980AL.

## 9. DCR Measurement Accuracy Test

### **Description**

This test checks the DCR measurement accuracy of the E4980A/ E4980AL.  
(Option: 001 only)



## 3 Adjustment

This chapter provides the adjustment information for the E4980A/ E4980AL to ensure that it is within its specifications. The adjustment must be performed by Keysight's qualified service personnel. If you need the adjustment for your E4980A/ E4980AL, it should be sent to the nearest Keysight Technologies service office.

### Safety Considerations

This manual contains NOTES, CAUTIONs, and WARNINGs that must be followed to ensure the safety of the operator and to keep the instrument in a safe and serviceable condition. The adjustment must be performed by Keysight's qualified service personnel.

#### **WARNING**

**Any interruption of the protective ground conductor (inside or outside the equipment) or disconnection of the protective ground terminal can make the instrument dangerous. Intentional interruption of the protective ground system for any reason is prohibited.**

---

### Warm-up for Adjustment

Warm-up the E4980A/ E4980AL for at least 30 minute before performing any of the following Adjustment procedures to ensure proper results and correct instrument operation.

### Required Equipment

**Table 1-1 on page 20** lists the equipment required to perform the Adjustment procedures described in this chapter. Use only calibrated test equipment when adjusting the E4980A/ E4980AL.

## Required Adjustment after Replacing Assembly

After replacing the following assembly, the adjustment items described in **Table 3-1** are required. The adjustment must be performed by Keysight's qualified service personnel. If you need the adjustment for your E4980A/ E4980AL, it should be sent to the nearest Keysight Technologies service office.

**Table 3-1** Required Adjustment Item after Replacing Assembly

Replaced Assembly	Adjustment Item												
	Writing ID	Write Null phase track default data	Null DC offset Adjustment	Null ADC DC offset Adjustment	ADC linearity Adjustment	DC Bias Adjustment	DC Level V monitor Adjustment	DC Level I monitor Adjustment	DC Source Adjustment	DCR Adjustment	Impedance Adjustment	AC Level monitor Adjustment	OSC Level Adjustment
PPMC PCA													
A1 Board													
A2 Board													
A3 Board													

### Writing ID

This item writes the serial number, option information into the A1 board of the E4980A/ E4980AL.

### Write Null Phase Track Default Data

The purpose of this procedure is to write the null phase track default data into A2 board

### Null DC Offset Adjustment

The purpose of this procedure is to adjust the null DC offset of the A2 board.

### Null ADC DC Offset Adjustment

The purpose of this procedure is to adjust the null ADC DC offset of the A2 board.

### ADC Linearity Adjustment

The purpose of this procedure is to adjust ADC non-linearity of the A2 board.

Adjustment  
Required Adjustment after Replacing Assembly

DC Bias Adjustment

The purpose of this procedure is to adjust the DC Bias level.

DC Level V Monitor Adjustment

The purpose of this procedure is to adjust the DC Level Monitor.

DC Level I Monitor Adjustment

The purpose of this procedure is to adjust the DC Level I Monitor.

DC Source Adjustment

The purpose of this procedure is to adjust the DC Source level.

DCR Adjustment

The purpose of this procedure is to adjust the DCR measurement.

Impedance Adjustment

The purpose of this procedure is to adjust the impedance measurement.

AC Level Monitor Adjustment

The purpose of this procedure is to adjust the AC level monitor.

OSC Level Adjustment

The purpose of this procedure is to adjust the OSC level.

Adjustment  
Required Adjustment after Replacing Assembly

## 4 Troubleshooting

This chapter provides the procedure to isolate a faulty assembly in the E4980A/ E4980AL.

### Introduction

**WARNING**

These servicing instructions are for use by qualified personnel only. To avoid possible electrical shock, do not perform any servicing unless you are qualified to do so.

---

**WARNING**

The opening of covers or removal of parts is likely to expose dangerous voltages. Disconnect the instrument from its power supply beforehand.

---

**CAUTION**

Many of the assemblies in the instrument are very susceptible to damage from ESD (electrostatic discharge). Perform the following procedures only at a static-safe workstation and wear a grounding strap.

---

**CAUTION**

DO NOT operate without following instructions. Programs or files in the instrument may be broken.

---

## To Troubleshoot the Instrument

This section describes the basic procedural flow of troubleshooting when servicing the E4980A/ E4980AL. The primary procedural tool in this section is the flowchart. The flowchart contains the entire troubleshooting path from a failure symptom to the isolation of faulty assembly, and will direct you to the completion of repair in an ordinary manner through the possible failure symptoms. Reference letters (Yes/No) on the flowcharts point to procedural steps that briefly explain the troubleshooting method to be performed next.

### Primary Trouble Isolation

The primary trouble isolation in **Figure 4-1** is to help direct you to the correct section for troubleshooting the E4980A/ E4980AL.

#### **Step 1.** Turn the E4980A/ E4980AL power on

With the E4980A/ E4980AL plugged in and the power turned off, the front panel orange standby LED should be on. When the front panel power switch is turned on, the orange LED should go out and the yellow-green LED should come on. Also, the fan should start rotating. In case of unexpected results, go to **“Power On Sequence Troubleshooting” on page 32.**

#### **Step 2.** Check the display

- The power on test is executed once automatically before the measurements start. If the power on test fails, go to **“Troubleshooting Using Service Function” on page 36.**
- If one of the following error messages **A1 EEPROM write error, CPU Bd EEPROM write error, CPU Bd FLASH ROM write error, Fan failed, or Power failed** is displayed during the measurement process, go to **“Power On Sequence Troubleshooting” on page 32** (check booting process).

#### **Step 3.** Check the basic function

If the front-panel, LCD display, data storage, remote interface or another function (except for measurement part) does not work correctly, go to **“Function Specific Troubleshooting” on page 47.**

#### **Step 4.** Check the measurement function

If the E4980A/ E4980AL fails any of the performance tests, go to **“Performance test failure troubleshooting” on page 65.**

A faulty part should be replaced as outlined in Chapter 5 which gives replacement procedures for each part. The procedures required after part replacement are given in Chapter 6.

Figure 4-1 Primary trouble isolation flowchart

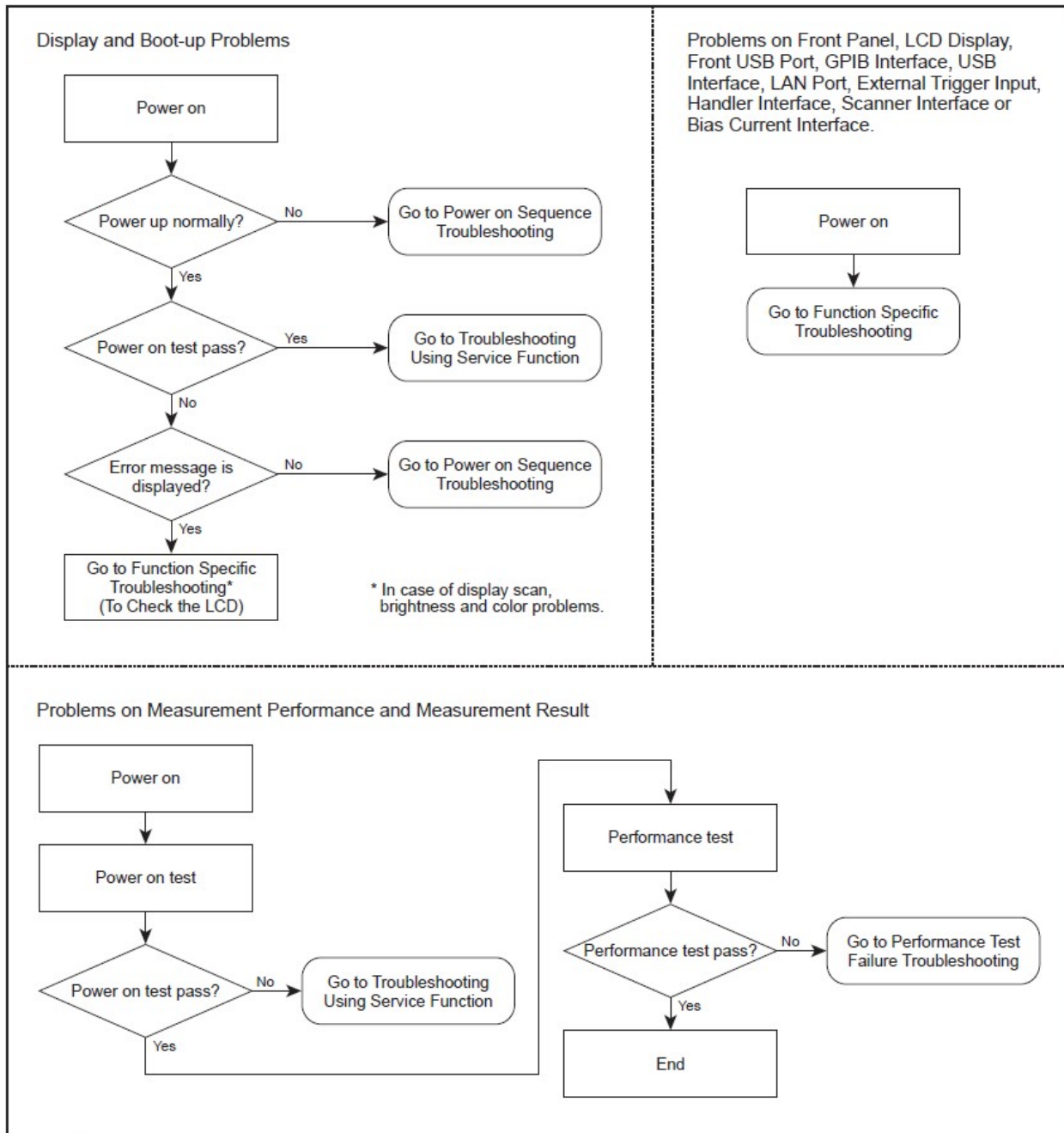

e4980ase1054

## Power On Sequence Troubleshooting

### Check the Line Voltage and Fuse

Check the main power line cord, power fuse, and actual line voltage to see that they are all correct. For more information about the line cord and power fuse, see the Power Requirements in Appendix B.

### Check the Power Supply Unit Output

- Step 1.** Remove the E4980A/ E4980AL's outer cover.
- Step 2.** Turn the E4980A/ E4980AL power on.
- Step 3.** Measure the output voltage (+3.3, +5, +12, -12 V) of the power supply unit using a voltmeter with a small probe. The location of each voltage connector on the A1 board and A3 board is shown in [Figure 4-2](#).



Figure 4-2

Output Voltage Location For MY46516000 (E4980A), SG46500500 (E4980A GSA), MY54304301 (E4980AL), SG54300100 (E4980AL GSA) and below.

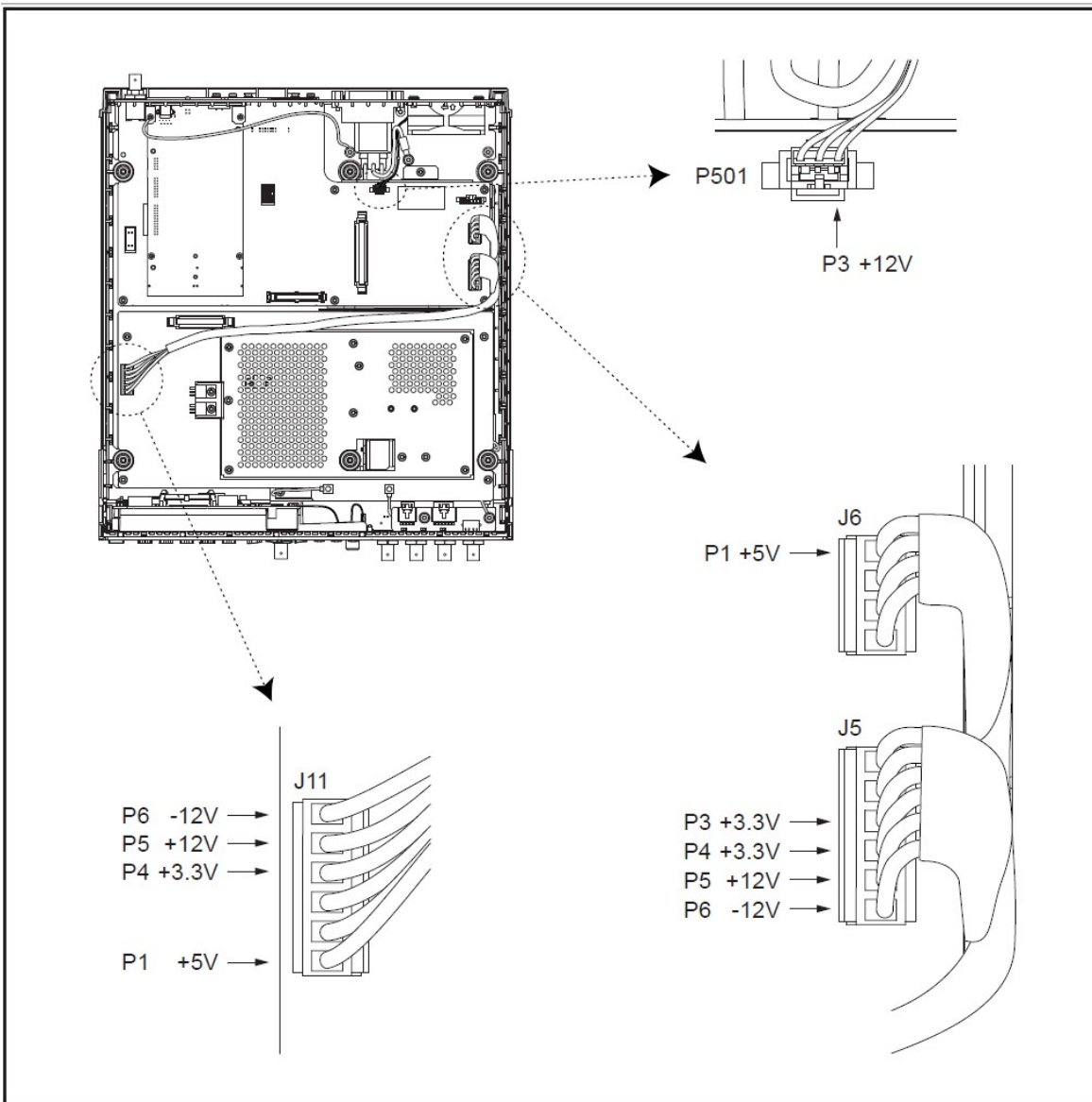
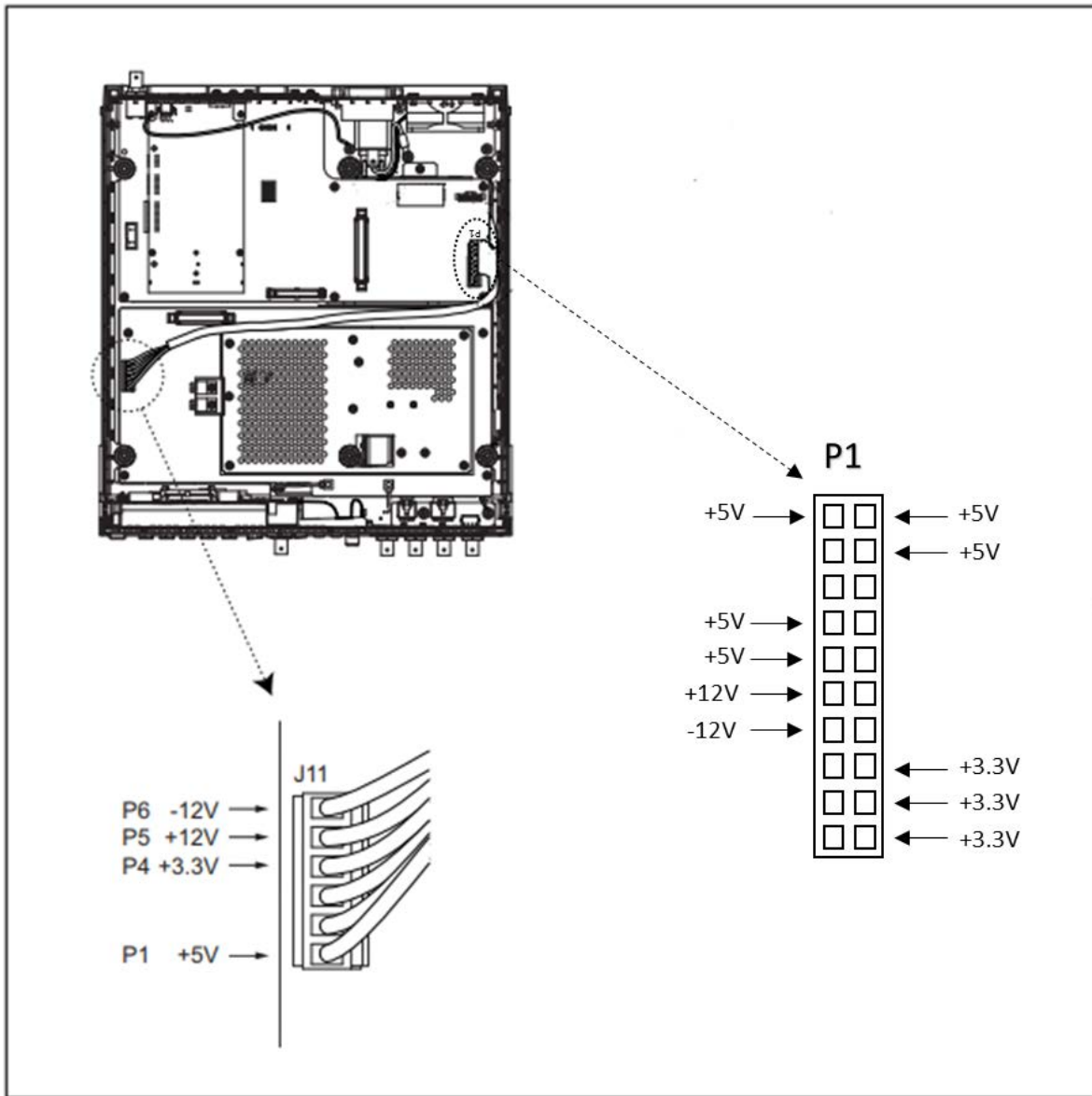

Figure 4-3

Output Voltage Location For MY46516001 (E4980A), SG46500501 (E4980A GSA), MY54304302 (E4980AL), SG54300101 (E4980AL GSA) and above.



- If the voltmeter reading is not within the following limits, replace the power supply unit.

Table 4-1

Power Supply Unit Output

Supply	Range
+ 3.3 V	+ 3.2 to + 3.4
+ 5 V	+ 4.8 to + 5.2
+ 12 V	+ 11.4 to + 12.6

Table 4-1

Power Supply Unit Output

Supply	Range
- 12 V	- 11.4 to -12.6

- If the voltmeter reading is within the limits, the power supply is verified.

Check booting process

If the power on sequence has a problem despite it being powered from the power supply unit properly, check the following events in this order.

1. With the E4980A/ E4980AL plugged in and the power turned off, the orange standby LED should be on. If the orange LED doesn't light, check the key flex circuit, display interface board, A1 board, and relevant cables.
2. When the front panel power switch is turned on, the orange LED should go out and the yellow-green LED should come on. If the yellow-green LED doesn't light, check the key flex circuit, display interface board, A1 board, and relevant cables.
3. Three LEDs (+3.3V, +5V, and POWERGOOD) on the A1 board should be on. If the LEDs don't light, a problem in the A1 board is suspected.
4. The fan should be rotating and audible. If the fan doesn't run, it is probably defective.
5. The LED on the display interface board should blink. If the LED doesn't blink, check the display interface board, the A1 board, and the relevant cable.
6. The firmware revision and hardware option information along with copyright declaration should be displayed. If nothing is displayed, check the LCD, display interface board, inverter board, and the relevant cables.
7. The power on test should be executed once automatically before the measurement starts. If the power on test fails, an error code or an error message is displayed. For more details, refer to "Troubleshooting using service function".
8. The measurement view should be displayed.
9. If the following error message **A1 EEPROM write error** is displayed during the measurement process, a problem in the A1 board is suspected.
10. If the following error message **CPU Bd EEPROM write error**, or **CPU Bd FLASH ROM write error** is displayed during the measurement process, a problem in the PPMC PCA is suspected.
11. If the following error message **Fan failed** is displayed during the measurement process, a problem in the fan is suspected.
12. If the following error message **Power failed** is displayed during the measurement process, a problem in the power supply is suspected.

## Troubleshooting Using Service Function

The Keysight E4980A/ E4980AL has a service function to diagnose the analog measurement section, digital section, and internal DC power supply voltages. The Power On Test or Self Test of the service function makes it possible to isolate a faulty board assembly.

### Power On Test

The Power On Test always takes place once the E4980A/ E4980AL is turned on. When a failure is detected, a message "Power on test failed" is displayed in the system message area and the normal measurement screen does not appear (Service Mode). The Service Mode is a state that occurs when the power-on test fails. Here, the characters on the display turn yellow and all of the front panel keys are unavailable.

#### NOTE

When you want to use the front panel keys in the Service Mode while carrying out any repairs to the unit, Power Switch + Preset keys can be pressed. The characters on the display turn yellow too, but you can use all keys.

### Contents of the power on test results

The Power On Test contains tests as shown in [Table 4-2](#). If the power on test is failed, an error code or an error message is also displayed. You can identify a failure section with the error code or the error message. The error code or error message is related to each test group as shown in [Table 4-2](#). For example, the first item of the error code is for CPU test group, second item is for System test group, and seventh item is for A3 test group. The value for each test group is given in hexadecimal.

Example of error code: Power on test failed: 0,0,0,0,0,3f,1f

#### NOTE

When the test no.1 or 2 of System test group fails, tests of A1, A2, A3 test groups are not performed. In case of this failure, the value for the fifth, sixth, and seventh item is indicated as ffff.

### Self Test

The Self Test can perform some test items of the power on test. Pressing the [System] key followed by the **SELF TEST** softkey opens the SELF TEST page. The SELF TEST page, intended for maintenance and repair, allows you to check the digital and analog behavior of E4980A/ E4980AL. You can choose one of the available test items with the cursor placed in the corresponding field (parenthesized field).

- Choosing a Test Item (TEST No. field)

[Figure 4-4](#) shows the fields available on this page along with the softkeys corresponding to them.

Figure 4-4

SELF TEST Page

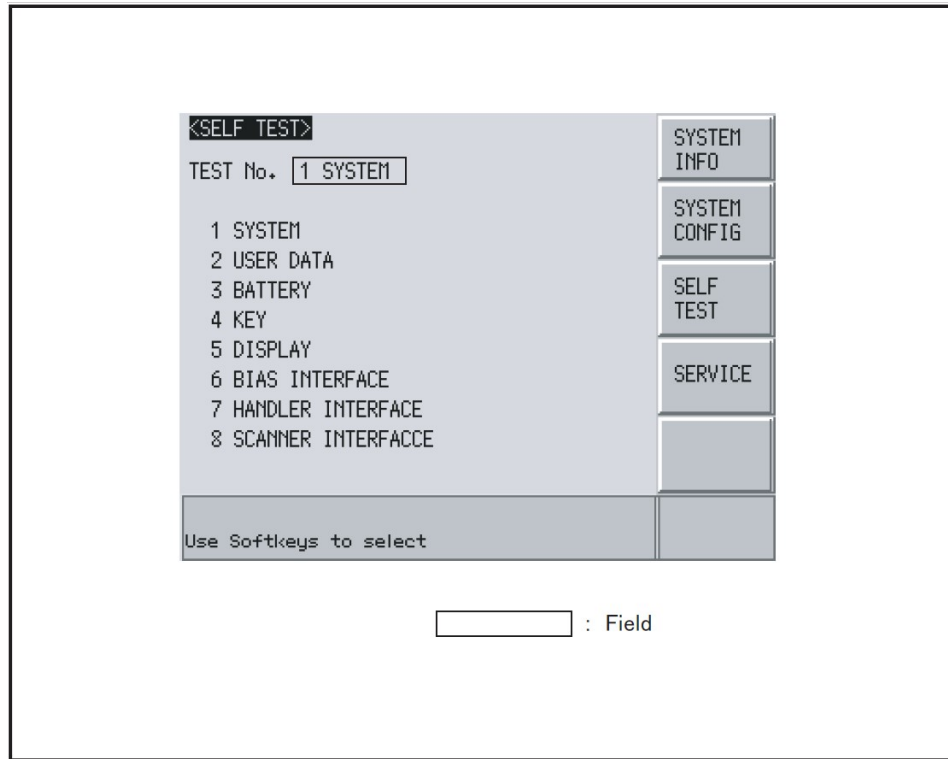

### Choosing a Test Item

#### Functional Description

E4980A/ E4980AL can run the following self tests:

The tests of SYSTEM, USER DATA, and BATTERY are also performed by the power on test.

Test item	Description
SYSTEM	Checks the entire system, A1/A2/A3 boards, system calibration data, and so on.
USER DATA	Checks the GPIB/LAN configurations, instrument configuration information, instrument calibration data, and scanner calibration data.
BATTERY	Checks the internal batteries.
KEY	Checks the front panel keys. (Visual checks only; no result shown on screen.)
DISPLAY	Checks the front panel LEDs and LCD. (Visual checks only; no result shown on screen.)

Test item	Description
BIAS INTERFACE	Checks the bias interface. (Visual checks only; no result shown on screen.)
HANDLER INTERFACE	Checks the handler interface. (Visual checks only; no result shown on screen.)
SCANNER INTERFACE	Checks the scanner interface. (Visual checks only; no result shown on screen.)

### Executing the self-test from the front panel

The self-test of the E4980A/ E4980AL can be executed from the front panel. The steps are given below.

#### Self-test procedure

- Step 4.** Press [System] - **SELF TEST**
- Step 5.** Use the cursor key to highlight the selection item to the right of “TEST No.” (1 in [Figure 4-5](#))
- Step 6.** Select the number corresponding to the test that you want to perform by using the **INCR+** and **DECR-** softkeys.
- Step 7.** Press **EXECUTE - TEST START** (2 in [Figure 4-5](#)) to execute the selected test item.

Figure 4-5 Self-test screen and procedure

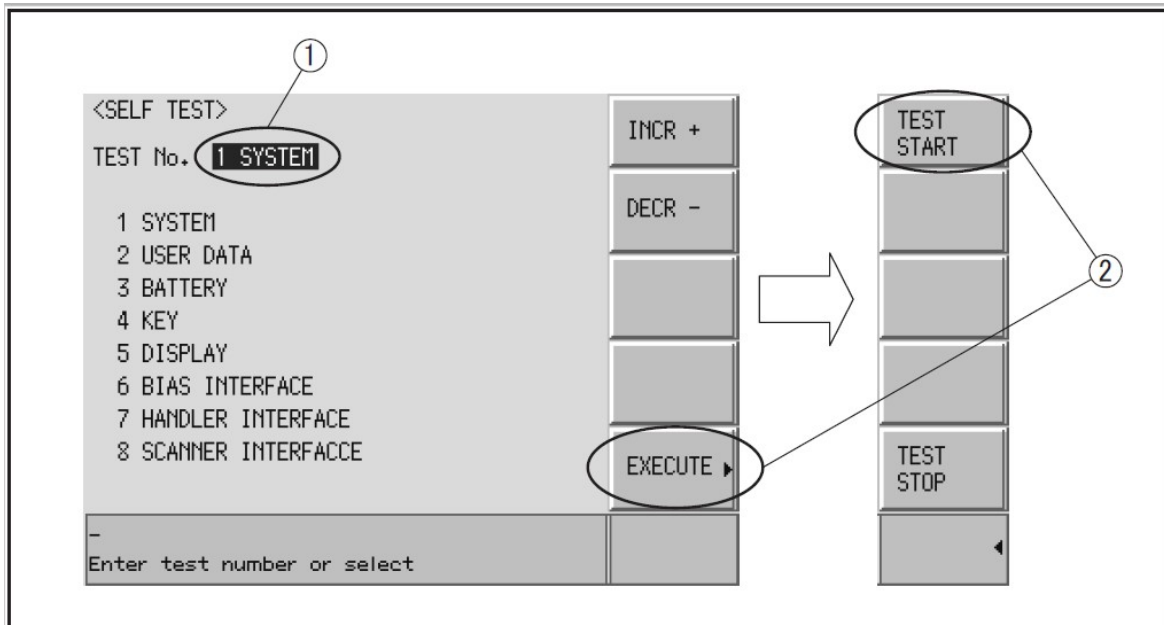

## SERVICE Page

The results of the power on test or the self test (SYSTEM, USER DATA, and BATTERY) can be saved into a USB memory. Pressing the [System] key followed by the **SERVICE** softkey opens the SERVICE page.

This page is read-only.

This page displays the system information of E4980A/ E4980AL and allows you to save the displayed information into the USB memory, but does NOT allow you to modify or delete the information.

### NOTE

The system information of E4980A/ E4980AL may be used for the purposes of support and repair by Keysight Technologies, but will never be used for any other purposes.

Figure 4-6

SERVICE Page

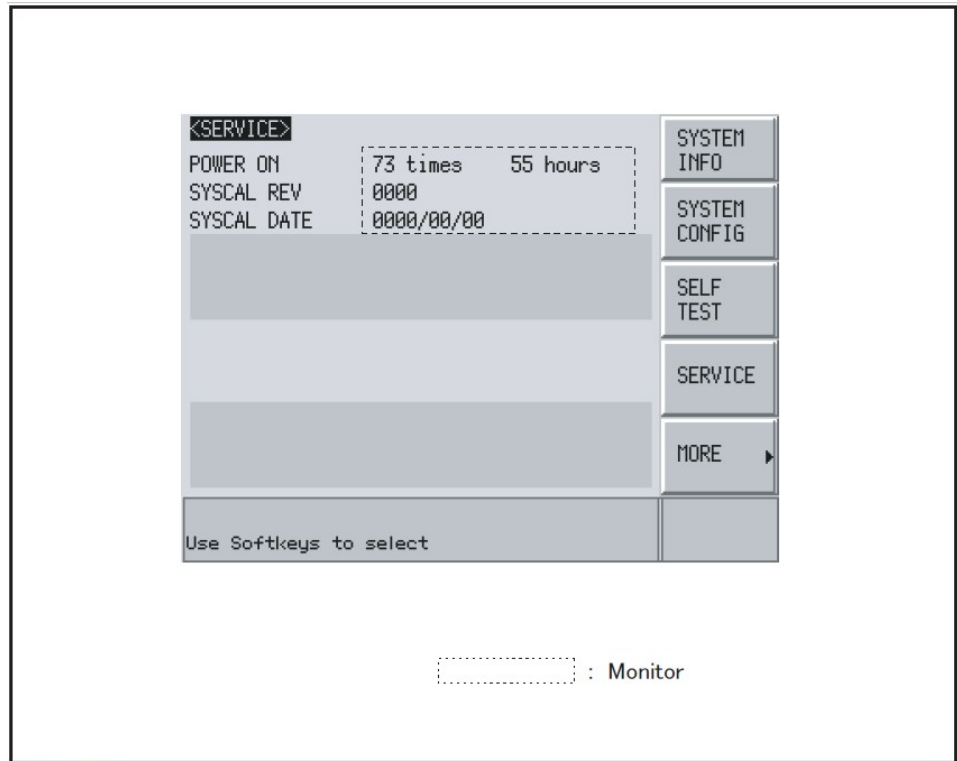

## Monitor Information

The SERVICE page displays the following monitor information, which cannot be edited on the SERVICE page.

Monitor Information	Description
POWER ON	Displays how many times E4980A/ E4980AL have been started up and its cumulative power-on time.
SYSCAL REV	Displays the program revision of the adjustment for the E4980A/ E4980AL.
SYSCAL DATE	Displays the date of the last adjustment for the E4980A/ E4980AL.

## Saving the System Information into External Memory

The system information of E4980A/ E4980AL can be saved into external memory.

The system information may be used for the purposes of support and repair by Keysight Technologies.

The file location on the USB memory is as follows:

```
\e4980a\system\sysinfo.txt
```

### NOTE

The system information of E4980A/ E4980AL may be used for the purposes of support and repair by Keysight Technologies, but will never be used for any other purposes.

To save the system information into external memory:

- Step 1.** Plug a USB memory stick into the front USB port.
- Step 2.** Press [System].
- Step 3.** Press the **SERVICE** softkey.
- Step 4.** Press the **MORE** softkey.
- Step 5.** Press the **SAVE SYS INFO** softkey.
- Step 6.** While the data is being saved, a "PROCESSING..." message is shown on the display. When the data has been saved into the USB memory, a "Storing data completed." message appears in the system message area.

## Example of the System Information

The sysinfo.txt can be read by using an external computer (PC). The example of the system information is as follows:



(Firmware Revision A.xx.xx will have 2 exponential digit while Firmware Revision B.xx.xx will have 3 exponential digit output)

Example 4-1

System information

ID: Keysight Technologies,E4980A,MY12345678,A.01.00

OPT: 001,710,710

POWER CYCLE: 42

POWER ON HOURS: 22

SYSCAL REV: 1.00

SYSCAL DATE: 2006/3/9

R: Rev.1.00

CPU[1]: 0

CPU[2]: 0

SYST[1]: 0

SYST[2]: 0

SYST[3]: 0

SYST[4]: 0

SYST[5]: 0

DATA[1]: 0

DATA[2]: 0

DATA[3]: 0

DATA[4]: 0

OPT[1]: 0

OPT[2]: 0

OPT[3]: 0

OPT[4]: 0

OPT[5]: 0

OPT[6]: 0<sup>1</sup>

OPT[7]: 0<sup>1</sup>

A1[1]: -1.187504864E+01

A1[2]: +1.184382915E+01

A1[3]: +5.098754883E+00

---

1. Result for firmware revision A.xx.xx

A1[4]: +3.359375000E+00  
A1[5]: +2.504882813E+00<sup>1</sup> (+1.194595026E+000<sup>2</sup>)  
A1[6]: +5.090893269E+00<sup>1</sup> (+1.199511054E+000<sup>2</sup>)  
A1[7]: +5.075683594E+000<sup>2</sup>  
A2[1]: -2.337981556E-04  
A2[2]: -4.294419530E-01  
A2[3]: +4.937164751E-01  
A2[4]: +4.625371247E-01  
A2[5]: -4.599838385E-01  
A2[6]: +3.438261555E-01  
A3[1]: -4.189105189E-05  
A3[2]: -8.715481204E-01  
A3[3]: +8.746015586E-01  
A3[4]: -7.700712127E-01  
A3[5]: +2.887844449E-01  
USER[1]: 0  
USER[2]: 0  
USER[3]: 0  
USER[4]: 0  
BATT[1]: +3.247070313E+00  
+3.750000000E+01  
+4.474563461E-01  
+4.404803338E-01

---

1. Result for firmware revision A.xx.xx  
2. Result for firmware revision B.xx.xx

Power On Test / Self Test Failure Troubleshooting

**Table 4-2** represents the contents of the power on tests or self test and the relationships of failed tests to probable faulty board assemblies. If power on test failed is displayed or self test fail is displayed, replace the faulty board assembly as shown in **Table 4-2**.

**Table 4-2** Power on test / self test failure troubleshooting information

Test group	Test No.	Test Name	Error Code / Message	Probable faulty board assembly						
				A1	A2	A3	Bias IF	Handler	Scanner	PPMC
CPU	1	CPU Test	1 ~ ffff							###
	2	CPU Test	1 ~ ff							###
System	1	A1 FPGA check	0x01	###						#
	2	A2 FPGA check	0x02	##	###					#
	3	A1 Revision check	0x04	###						#
	4	A2 Revision check	0x08	##	###					
	5	A3 Revision check	0x10	##		###				
Data	1	System Data	0x01	###						#
	2	SysCal Data	0x02	##	###					#
	3	Flash File system check	0x04							###
	4	Test Limit Data	0x08							###

Table 4-2 Power on test / self test failure troubleshooting information

Test group	Test No.	Test Name	Error Code / Message	Probable faulty board assembly						
				A1	A2	A3	Bias IF	Handler	Scanner	PPMC
Option	1	Option 002 Off check <sup>1</sup> Option 201 Off check <sup>2</sup>	0x01	##			### <sup>1</sup>	### <sup>2</sup>		#
	2	Option 002 On check <sup>1</sup> Option 201 On check <sup>2</sup>	0x02	##			### <sup>1</sup>	### <sup>2</sup>		#
	3	Option 201 Off check <sup>1</sup> Option 301 Off check <sup>2</sup>	0x04	##				### <sup>1</sup>	### <sup>2</sup>	#
	4	Option 201 On check <sup>1</sup> Option 301 On check <sup>2</sup>	0x08	##				### <sup>1</sup>	### <sup>2</sup>	#
	5	Option 301 Off check <sup>1</sup> Option consistency check <sup>2</sup>	0x10	##					### <sup>1</sup>	#
	6	Option 301 On check <sup>1</sup>	0x20	## <sup>1</sup>					### <sup>1</sup>	# <sup>1</sup>
	7	Option consistency check <sup>1</sup>	0x40	## <sup>1</sup>						# <sup>1</sup>

Table 4-2 Power on test / self test failure troubleshooting information

Test group	Test No.	Test Name	Error Code / Message	Probable faulty board assembly						
				A1	A2	A3	Bias IF	Handler	Scanner	PPMC
A1	1	A1_DCBUS_M12V	0x01	###						
	2	A1_DCBUS_P12V	0x02	###						
	3	A1_DCBUS_P5V	0x04	###						
	4	A1_DCBUS_P3.3V	0x08	###						
	5	A1_DCBUS_P2.5V <sup>1</sup> A1_DCBUS_P1.2V_M GT <sup>2</sup>	0x10	###						
	6	A1_DCBUS_STANBY <sup>1</sup> A1_DCBUS_P1.2V <sup>2</sup>	0x20	###						
	7	A1_DCBUS_STANBY <sup>2</sup>	0x40	### <sup>2</sup>						
A2	1	A2_DCBUS_GND	0x01		###	#				
	2	A2_DCBUS_PM5V	0x02		###	#				
	3	A2_DCBUS_P3V	0x04		###	#				
	4	A2_DCBUS_P10V	0x08		###	#				
	5	A2_DCBUS_M10V	0x10		###	#				
	6	A2_DCBUS_TEMP	0x20		###	#				
A3	1	A3_DCBUS_GND	0x01		#	###				
	2	A3_DCBUS_N50V	0x02		#	###				
	3	A3_DCBUS_P50V	0x04		#	###				
	4	A3_DCBUS_N12V	0x08		#	###				
	5	A3_DCBUS_TEMP	0x10		#	###				

Table 4-2 Power on test / self test failure troubleshooting information

Test group	Test No.	Test Name	Error Code / Message	Probable faulty board assembly						
				A1	A2	A3	Bias IF	Handler	Scanner	PPMC
User	1	User Data	User Data Lost							###
	2	State Data	State Data Lost							###
	3	Correction Data	Corr Data Lost							###
	4	Scanner Correction Data	Scanner Data Lost							###
Battery	1	A1_DCBUS_BATTERY	Battery Low	###						

1. Only for firmware revision A.xx.xx
2. Only for firmware revision B.xx.xx

###: Most suspicious assembly  
 ##: Suspicious assembly  
 #: Possible faulty assembly

## Function Specific Troubleshooting

If the E4980A/ E4980AL exhibits a failure symptom that is related to a specific function or control such as a front panel key control, display, data storage, remote control interface, external trigger, isolate the trouble using the Function Specific Troubleshooting procedures described below. The major functions of the E4980A/ E4980AL and the troubleshooting procedure for each function are shown in **Table 4-3**.

**Table 4-3 Major functions and troubleshooting procedures**

Function	Description	Troubleshooting
Front panel keys	All the E4980A/ E4980AL functions can be set and controlled via the front panel keys.	Refer to <b>“To Check the Front Panel”</b> on page 48.
LCD display	Almost all the information including the measurement value, setup state, result data processing, menu bar, softkey label and others are indicated on the LCD display.	Refer to <b>“To Check the LCD”</b> on page 48.
Front USB port	The USB port is used to save data in a USB memory. The LED for USB lights up while accessing the USB memory.	Refer to <b>“To Check the Front USB port”</b> on page 49.
External trigger input	The external trigger input terminal (BNC) on the rear panel allows an external trigger source to be used for measurement trigger.	Refer to <b>“To Check the External Trigger Input”</b> on page 49.
LAN port	The LAN interface port on the rear panel allows the E4980A/ E4980AL to be connected to 10/100 Base-T Ethernet.	Refer to <b>“To Check the LAN”</b> on page 50.
GPIB Interface	The GPIB compatibility allows the E4980A/ E4980AL to be operated as a talker/listener on IEEE 488 interface bus.	Refer to <b>“To Check the GPIB”</b> on page 52.
USB (USBTMC) Interface	Through this port, you can control the E4980A/ E4980AL via external controllers. It is equivalent to control via GPIB.	Refer to in <b>“To Check the USB (USBTMC) Interface Card”</b> on page 52.
Handler interface (Option E4980A-201)	The interface is for data exchange with an automatic machine (handler) used on production line.	Refer to in <b>“To Check the Handler Interface Function (Option 201 only)”</b> on page 52.
Scanner interface (Option E4980A-301)	The interface to connect a scanner to perform up to 128 sets of multi-channel correction and measurements.	Refer to in <b>“To Check the Scanner Interface Function (Option 301 only)”</b> on page 57.

Table 4-3 Major functions and troubleshooting procedures

Function	Description	Troubleshooting
Bias current interface (Option E4980A-002)	The interface to connect the 42841A (Bias Current Source).	Refer to in “To Check the Bias Current Interface Function (Option 002 only)” on page 60.

#### To Check the Front Panel

##### Procedure

Randomly press the front panel keys to verify that they work normally.

- Step 1.** Press [System] - **SELF TEST**
- Step 2.** Use the cursor key to highlight the selection item to the right of “TEST No.”.
- Step 3.** Select **4 KEY** using the **INCR+** or **DECR-** softkey.
- Step 4.** Press **EXECUTE - TEST START**.
- Step 5.** Randomly press the front panel keys. The key name of the pressed key is displayed.
- Step 6.** To exit the front panel test, press **TEST STOP** three times consecutively, and then press [Return].
  - If multiple keys fail to work, a problem in key function (keypad, key flex circuit) or display interface board.
  - If only a specific key doesn't work, check first if the key is subsided in the panel.

#### To Check the LCD

##### Procedure

- Step 1.** Press [System] - **SELF TEST**
- Step 2.** Use the cursor key to highlight the selection item to the right of “TEST No.”.
- Step 3.** Select **5 DISPLAY** using the **INCR+** or **DECR-** softkey.
- Step 4.** Press **EXECUTE - TEST START**. The whole of the LCD screen turns Red, Green, Blue, Black, and White every 2 seconds.
- Step 5.** To exit the DISPLAY test, press **TEST STOP**, and then press [Return].
  - If the LCD display has a problem, check the LCD and the display interface board.
  - If the LCD is not illuminated with backlight, check the inverter board.



## To Check the Front USB port

### Procedure

**Step 1.** Plug a USB memory, formatted with FAT16 or FAT32.

#### NOTE

The following USB memory can be used.

Complies with USB 1.1; mass storage class, FAT16/FAT32 format; maximum consumption current is below 500 mA.

Recommended USB memory: Keysight 512 MB USB Flash memory (Keysight PN 1819-0195).

Use the prepared USB memory device exclusively for the E4980A/E4980AL; otherwise, other previously saved data may be cleared. If you use a USB memory other than the recommended device, data may not be saved or recalled normally.

**Step 2.** Press [Save/Recall].

**Step 3.** Use the cursor keys to select the MEDIA field.

**Step 4.** Press the **EXT** softkey.

**Step 5.** Use the cursor keys to select the No. 11.

**Step 6.** Press the **SAVE** softkey to save configuration states into the USB memory.

**Step 7.** Press [Save/Recall].

**Step 8.** Use the cursor keys to select the MEDIA field.

**Step 9.** Press the **EXT** softkey.

**Step 10.** Use the cursor keys to select the No. 11.

**Step 11.** Press the **RECALL** softkey to recall configurations from the USB memory.

If the file save or recall operation fails, a failure in the USB port or A1 board is suspected. Also check the cable between the USB port and A1 board.

## To Check the External Trigger Input

### Procedure

**Step 1.** Press [Preset] - **CLEAR SETTING** - **OK** to initialize the E4980A/ E4980AL.

**Step 2.** Press [Meas Setup].

**Step 3.** Using the cursor keys, select the TRIG field, and then select **EXT** softkey.

**Step 4.** Press [Display Format].

- Step 5.** Connect a BNC Short or 50  $\Omega$  termination to the Ext Trig connector on the rear panel and disconnect it. Thereby a measurement trigger should be generated and a measurement result should be refreshed.
- Step 6.** If no trigger occurs, a failure in the A1 board is suspected.

To Check the LAN

### Procedure

- Step 1.** Connect a LAN cable between the LAN port on the rear panel and an external computer (PC).

#### NOTE

Use a crossed LAN cable to enable the peer-to-peer communication between the E4980A/ E4980AL and the PC. If the E4980A/ E4980AL needs to be connected to the PC via a multi port Hub, use a straight LAN cable.

- Step 2.** Press [System].
- Step 3.** Press the **SYSTEM CONFIG** softkey.
- Step 4.** Select the DHCP ENABLED field using the cursor keys and then press the **OFF** softkey.
- Step 5.** Select the AUTO-IP ENABLED field using the cursor keys and then press the **OFF** softkey.
- Step 6.** Enter the following IP address and subnet mask using the enter keys. For selecting the MANUAL IP ADDR or MANUAL SUBNET MASK field, use the cursor keys.
- IP Address: 192.168.0.1
- Subnet Mask: 255.255.255.0
- Step 7.** Set up the IP address/subnet mask for the external PC.
- Double-click "**My Computer**" icon on Windows desktop of the external PC. And double-click **Control Panel**. The Control Panel window will appear.
  - In the Control Panel window, double-click **Network**. The Network dialog box will appear. In the **Configuration** tab, select **TCP/IP** (display it in reverse video) and press the **Properties** button.
  - The dialog box appears. If **Specify an IP address** has been selected, record the IP address and subnet mask.
  - If the **Obtain an IP address automatically** has been selected, select the **Specify an IP address**. Enter the IP address xxx.xxx.xxx.y and subnet mask xxx.xxx.xxx.xxx as shown in **Figure 4-7**. The letters x represent the IP address and subnet mask of the E4980A/ E4980AL. The letter y is different from the IP address of the E4980A/ E4980AL. Press the **OK** button. Then, restart the external PC.

Figure 4-7 Network Dialog Box ("IP Address" Tab)

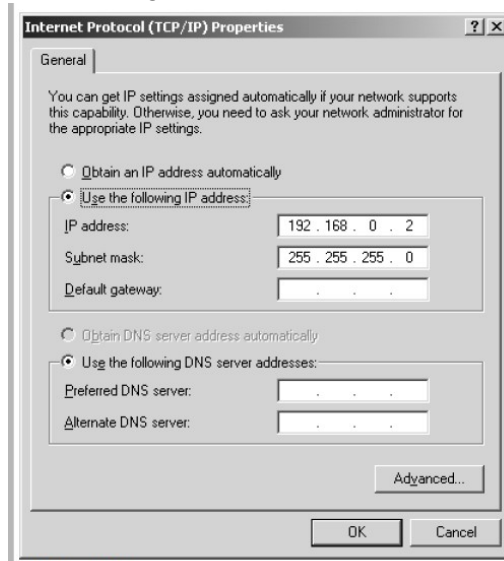

**Step 8.** By clicking "OK" button, the network settings take effect. Verify the E4980A/ E4980AL LAN settings and response to a command from the external computer as follows:

- a. On the external computer, click "Start" button in the Windows Start menu bar using a mouse.
- b. Click "Programs" and "MS-DOS Prompt" (or "Command Prompt") to open the DOS (Command) Prompt window.
- c. Type a ping command followed by the E4980A/ E4980AL IP address as "ping xxx.xxx.xxx.xxx" (where, xxx.xxx.xxx.xxx is the IP address such as 192.168.0.1 assigned in step 3-d.) Press [Enter] key on the keyboard.
- d. The external computer displays a message of ping command response from the E4980A/ E4980AL. Figure 4-8 shows an example of normal result that indicates the IP address, packet size, and a response time counted by the computer. The ping command is repeated 4 times.

Figure 4-8 Example of normal ping command test result

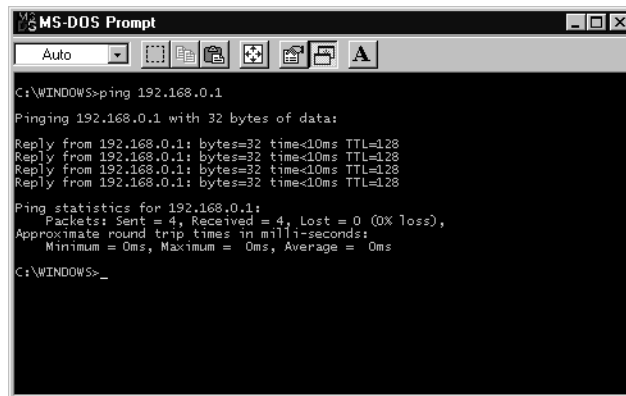

If the E4980A/ E4980AL doesn't return the response, the external computer displays a message of "Request timed out" as shown in Figure 4-9. In this case, a failure in the PPMC PCA is suspected.

Figure 4-9 Example of no response for ping command

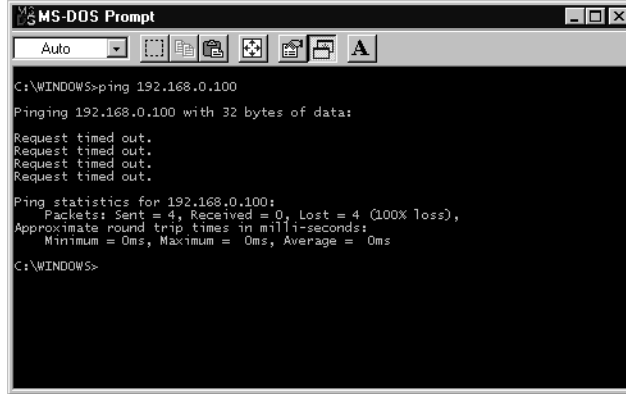

To Check the GPIB

### Procedure

Perform the E4980A/ E4980AL performance test program. If the controller cannot detect the E4980A/ E4980AL, the problem seems in the PPMC PCA or the connection of the GPIB cable.

To Check the USB (USBTMC) Interface Card

### Procedure

Connect the USB cable between the controller PC and the E4980A/ E4980AL. Turn the controller PC on. If the E4980A/ E4980AL cannot detect the controller PC, the problem seems in the USB (USBTMC) Interface of the PPMC PCA is suspected.

To Check the Handler Interface Function (Option 201 only)

Perform this test only when troubleshooting the Option 201 Handler Interface Board. This test verifies the handler interface functions.

### Equipment

Table 4-4 Equipment List of the Handler Interface Function Test (Option 201 only)

Handler Simulator	Keysight p/n 04278-65001
-------------------	--------------------------

## Procedure

- Step 1.** Disconnect the power cable from the E4980A/ E4980AL and allow 1 minute for the internal capacitors to discharge.

### NOTE

Dangerous energy/voltage exists when the E4980A/ E4980AL is in operation, and for a time after it is powered down. Allow 1 minutes for the internal capacitors to discharge.

- Step 2.** Remove the Handler Interface Board according to the procedure for describing in “Handler Interface” Chapter of the User’s Guide.

### NOTE

The interface board contains electronic components that can be damaged by static electricity through electrostatic discharge (ESD). To prevent ESD damage, maintain frequent contact with any bare sheet metal surface on the chassis. A grounding wrist strap (or similar device) is useful for this purpose. Handle the board carefully at all times. Avoid touching electronic components or circuit paths.

### NOTE

Before performing **Step 3**, note the jumper and switch settings on the handler interface board in order to return them to the same settings at the end of this function test.

- Step 3.** Set the jumpers and switch on the handler interface board to the same settings as when the board is shipped from the factory. Refer to **Figure 4-10**, **Table 4-5**, and **Table 4-6**.

Figure 4-10 Jumper, and Switch Settings

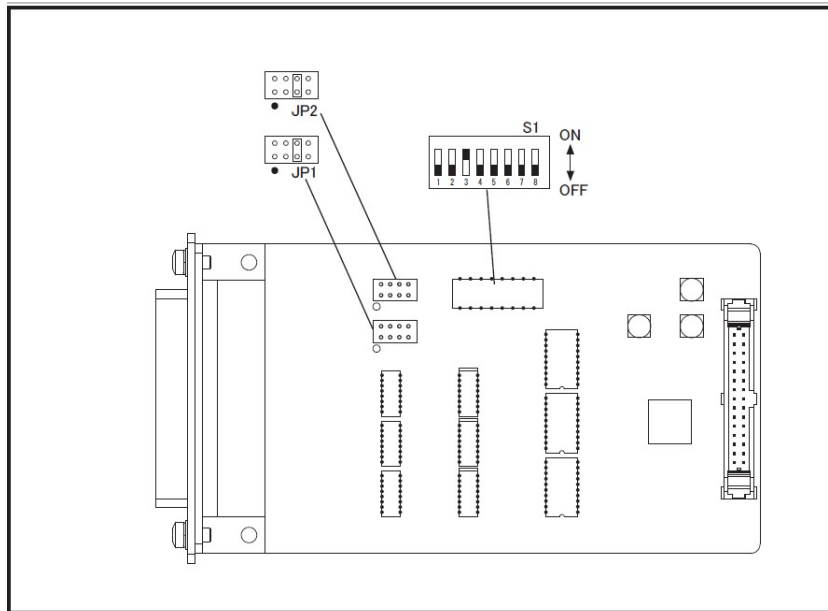

Table 4-5 Internal jumper settings

Jumper number	Jumper position <sup>1</sup>
JP1	1
	2
	3(N)
	4
JP2	1
	2
	3(N)
	4

1. The factory default setting is position (N) shown in the table above.

Table 4-6 Bit switch (S1) settings

Bit number <sup>1</sup>	Factory default settings
1	Off
2	Off
3	On
4	Off
5	Off
6	Off
7	N.A.
8	N.A.

1. The bit numbers referenced in this table are the numbers printed on the bit switch (S1) of the handler interface board.

**Step 4.** Replace the handler interface board.

**Step 5.** Turn the E4980A/ E4980AL ON.

**Step 6.** Connect the handler interface connector on the E4980A/ E4980AL's rear panel to the handler simulator as shown in [Figure 4-11](#).

Figure 4-11 Handler Interface Function Test Setup

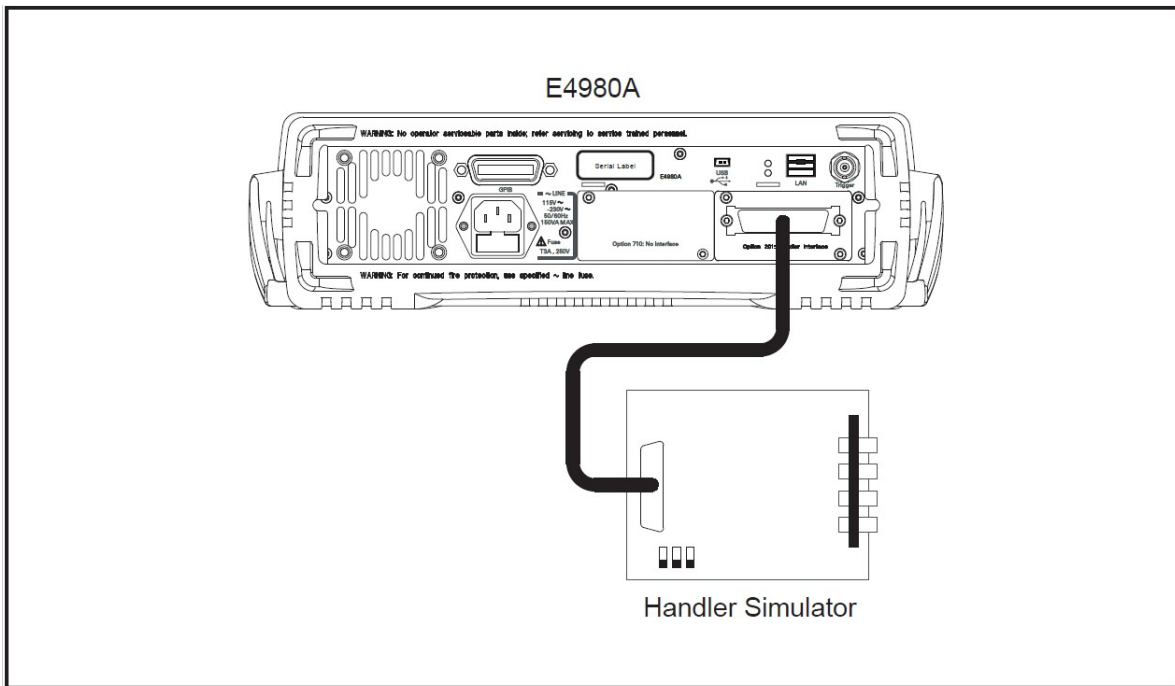

**Step 7.** Press [System].

**Step 8.** Press the **SELF TEST** softkey to display the **SELF TEST** page.

**Step 9.** Use the **CURSOR** arrow keys to move the cursor to the **TEST MENU** field.

**Step 10.** Use the softkeys to select the **HANDLER INTERFACE** test.

Softkey	Function
<b>INCR +</b>	Increments the test number of the Test Menu.
<b>DECR -</b>	Decrements the test number of the Test Menu.

**Step 11.** Press the **EXECUTE - TEST START** softkeys to execute the **HANDLER INTERFACE** test.

**Step 12.** Confirm that the LEDs on the handler simulator turn ON in accordance with the E4980A/ E4980AL's output signals displayed on the LCD. The LEDs turns ON light in the sequence shown in [Figure 4-12](#).

Figure 4-12 Handler Interface Function Check

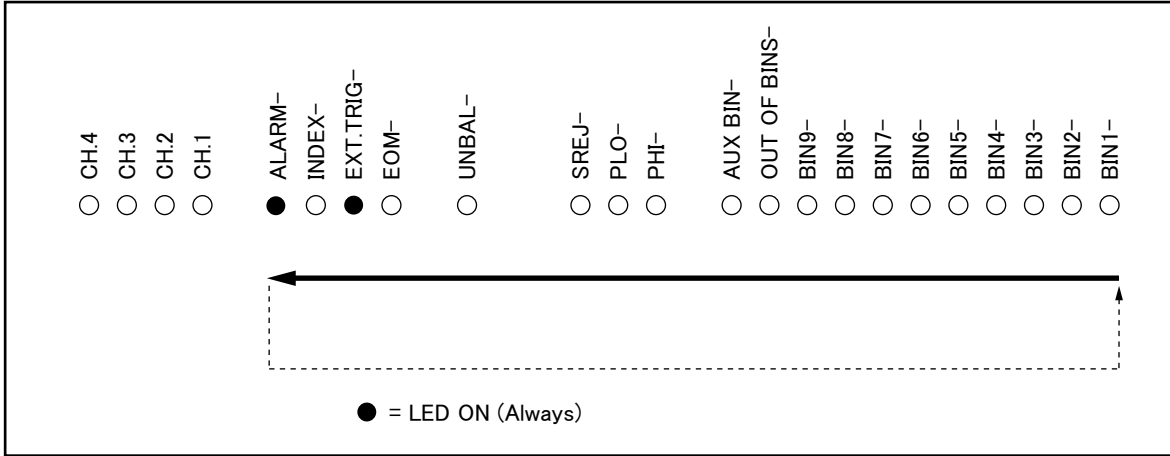

**Step 13.** Press the **TEST STOP** softkey.

**NOTE**

Do not execute any SELF TEST except for the Handler Interface Test or the E4980A/ E4980AL will become inoperative.

**Step 14.** Return the jumper and switch settings on the handler interface board to their original settings.



### To Check the Scanner Interface Function (Option 301 only)

Perform this test only when troubleshooting the Option 301 scanner interface board. This test verifies the scanner interface function.

#### Equipment

Table 4-7

Equipment List of the Scanner Interface Function Test (Option 301 only)

Scanner Simulator	Keysight p/n 04278-65301
DC Power Supply	Keysight E3610A
1 k $\Omega$ Standard	Keysight 42030A (42037A)

#### Procedure

- Step 1.** Disconnect the power cable from the E4980A/ E4980AL and allow 1 minute for the internal capacitors to discharge.

#### NOTE

Dangerous energy/voltage exists when the E4980A/ E4980AL is in operation, and for a time after it is powered down. Allow 1 minutes for the internal capacitors to discharge.

- Step 2.** Remove the Scanner Interface Board according to the procedure for describing in “Scanner Interface” Chapter of the User’s Guide.

#### NOTE

The interface board contains electronic components that can be damaged by static electricity through electrostatic discharge (ESD). To prevent ESD damage, maintain frequent contact with any bare sheet metal surface on the chassis. A grounding wrist strap (or similar device) is useful for this purpose. Handle the board carefully at all times. Avoid touching electronic components or circuit paths.

#### NOTE

Before performing **Step 3**, note the switch settings on the scanner interface board in order to return them to the same settings at the end of this function test.

- Step 3.** Set S1 and S2 on the scanner interface board to the same settings as when the board is shipped from the factory referring to **Figure 4-13**, **Table 4-8**, and **Table 4-9**.

Figure 4-13 Switches Setting

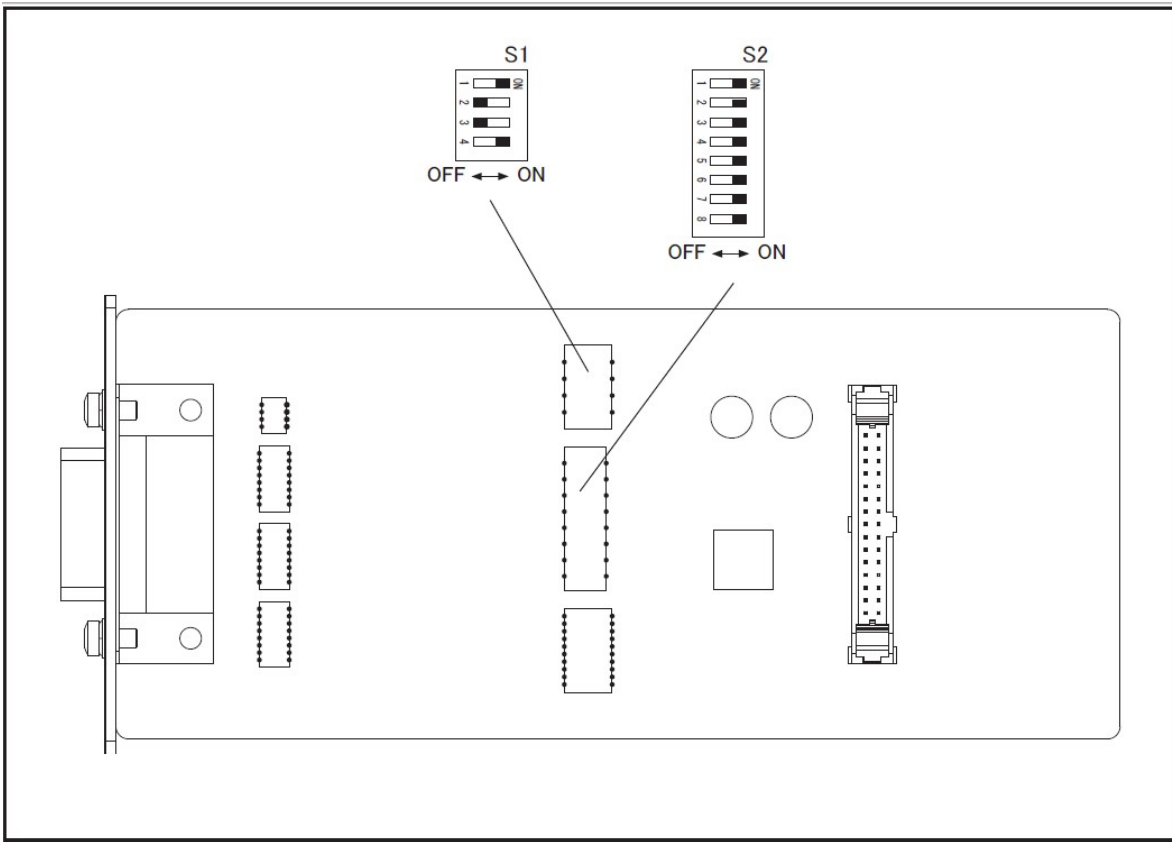

Table 4-8 Setting Bit Switch (S1)

Bit	Default
1 <sup>1</sup>	On
2 <sup>1</sup>	Off
3 <sup>1</sup>	Off
4	On

1. For bits 1 to 3 of bit switch S1, only one bit can be turned on at one time.

Table 4-9 Setting Bit Switch (S2)

Bit	Default
1-8	On

**NOTE**

Bit switches S1 and S2 can be identified by the labels “S1” and “S2” on the scanner interface board.

- Step 4.** Replace the scanner interface board.
- Step 5.** Set DC power supply output voltage +5 V. Connect TP2 (GND) on the bias interface simulator to ‘-’ terminal of the power supply. Then connect TP1 (Vcc) on the simulator to ‘+’ terminal of the power supply. (Refer to Figure 4-14.)

Figure 4-14 Scanner Simulator Connections

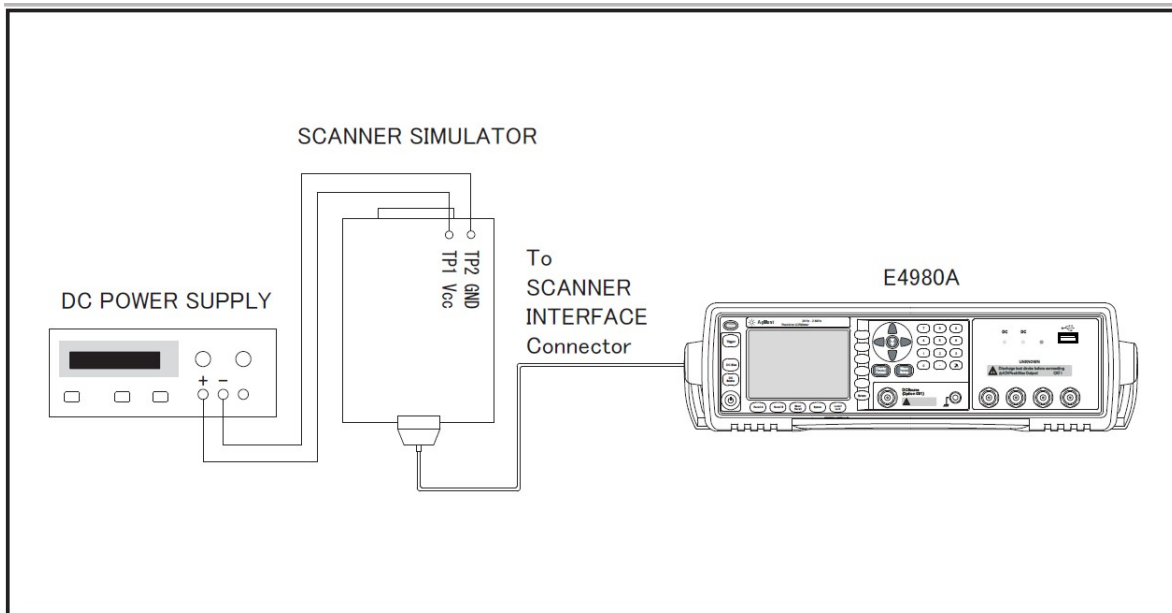

**NOTE**

DC power for the bias interface simulator can be supplied from the E4980A/ E4980AL instead of an external DC power supply.

- Step 6.** Connect the scanner simulator to the scanner interface connector on the E4980A/ E4980AL's rear panel shown in [Figure 4-14](#).
- Step 7.** Connect the 1 k $\Omega$  standard to the UNKNOWN terminal on the E4980A/ E4980AL's front panel.
- Step 8.** Turn the E4980A/ E4980AL ON.
- Step 9.** Press [System].
- Step 10.** Press the **SELF TEST** softkey to display the **SELF TEST** page.
- Step 11.** Use the **CURSOR** arrow keys to move the cursor to the **TEST MENU** field.

**Step 12.** Use the softkeys to select the **SCANNER INTERFACE** test.

Softkey	Function
<b>INCR +</b>	Increments the test number of the Test Menu.
<b>DECR -</b>	Decrements the test number of the Test Menu.

**Step 13.** Press the **EXECUTE - TEST START** softkeys to execute the **SCANNER INTERFACE** test.

**Step 14.** Confirm that LEDs on the scanner simulator board turn ON in accordance with the E4980A/ E4980AL settings displayed in the LCD.

**Step 15.** Press the **TEST STOP** softkey.

**NOTE**

Do not execute any SELF TEST except for the Scanner Interface Test or the E4980A/ E4980AL will become inoperative.

**Step 16.** Return the switch settings on the scanner interface board to their original settings.

To Check the Bias Current Interface Function (Option 002 only)

This test verifies the bias current interface functions.

**Equipment**

Table 4-10

Equipment List of the Bias Current Interface Function Test (Option 002 only)

Bias Interface Simulator	Keysight p/n 42841-65001
Bias Interface Cable	Keysight p/n 42841-61640
DC Power Supply	Keysight E3610A
Adapter	Keysight p/n E4980-60102

**Procedure**

**Step 1.** Set all switches of S1 and S2 on the bias interface simulator to '1' as shown in **Figure 4-15**.

Figure 4-15 Bias Interface Simulator

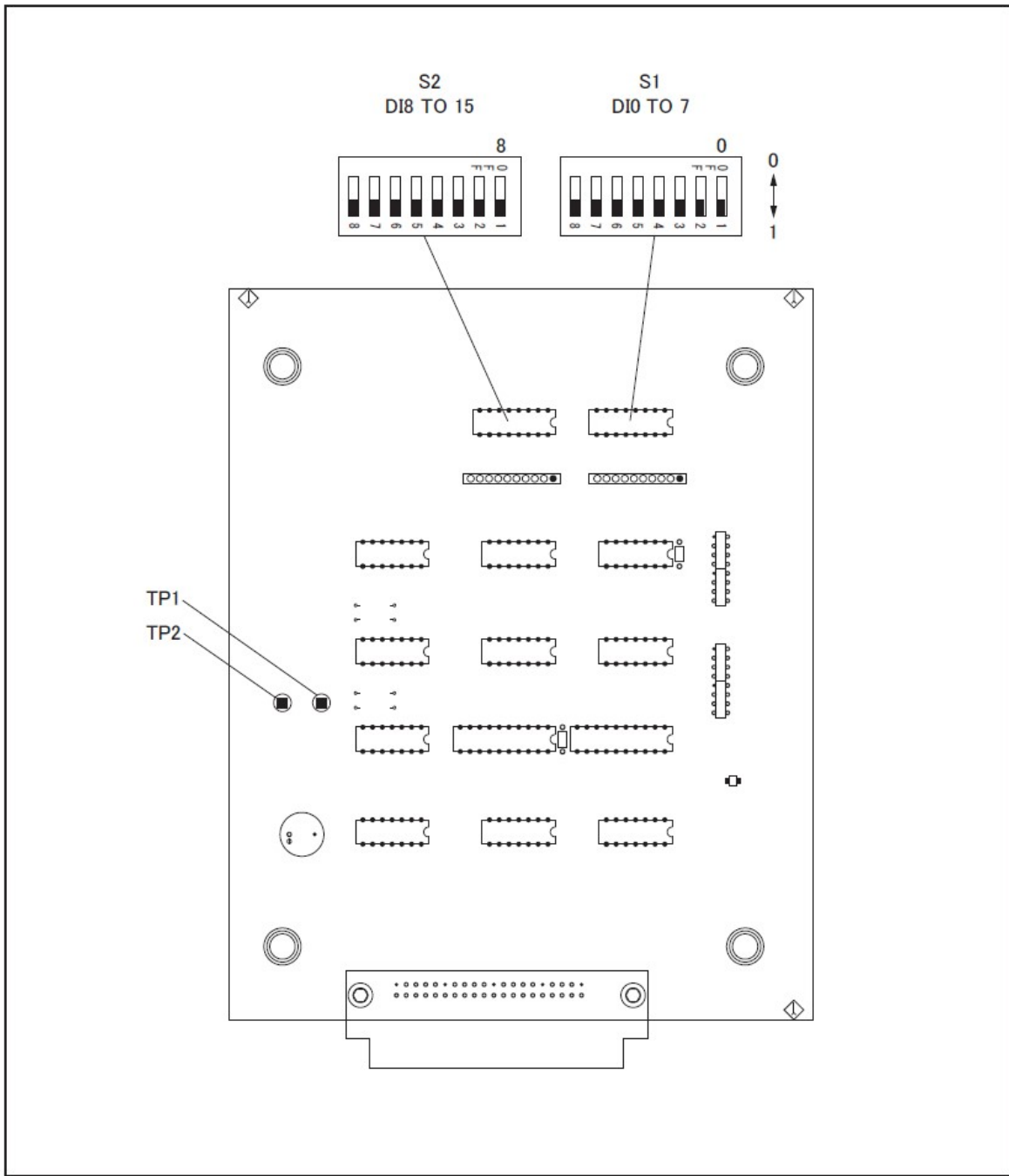

**Step 2.** Set DC power supply output voltage +5 V. Connect TP2 (GND) on the bias interface simulator to '-' terminal of the power supply. Then connect TP1 (Vcc) on the simulator to '+' terminal of the power supply. (refer to Figure 4-15 and Figure 4-16.)

**NOTE**

DC power for the bias interface simulator can be supplied from the E4980A/ E4980AL instead of from an external DC power supply.

**Step 3.** Interconnect the bias interface simulator and bias interface connector on the rear panel of the E4980A/ E4980AL with the bias interface cable as shown in Figure 4-16.

**NOTE**

Connect using the adapter between the bias interface connector on the rear panel of the E4980A/ E4980AL and the bias interface cable, when you execute this step.

Figure 4-16 Bias Current Interface Function Test Setup

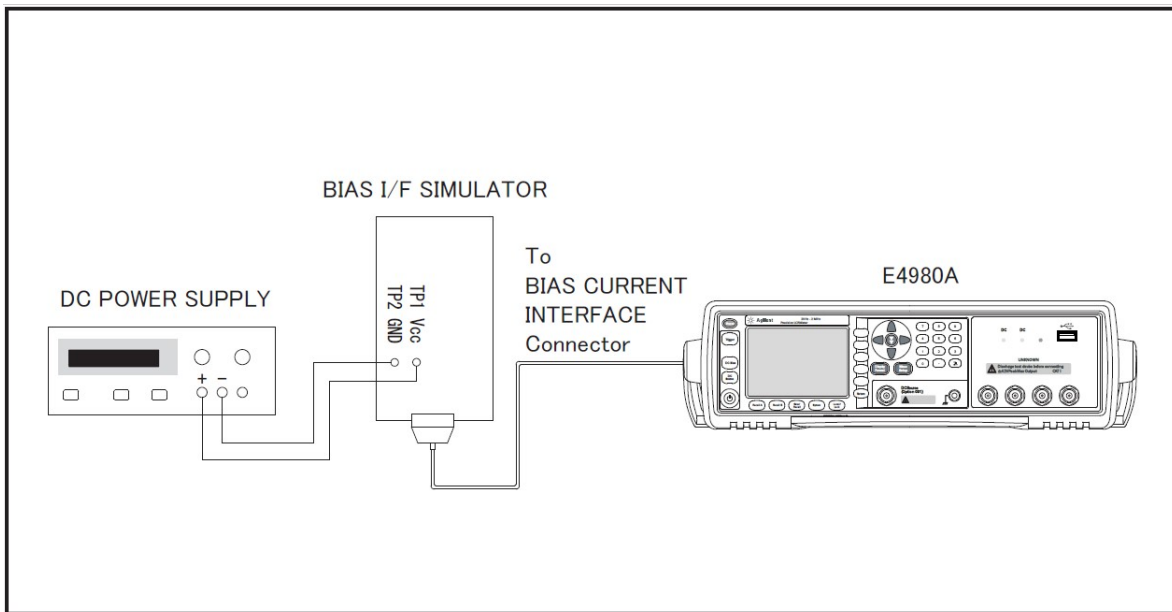

-4980---1047

**Step 4.** Turn the E4980A/ E4980AL ON.

**Step 5.** Press [System].

**Step 6.** Press the **SELF TEST** softkey to display the **SELF TEST** page.

**Step 7.** Use the **CURSOR** arrow keys to move the cursor to the **TEST MENU** field.

**Step 8.** Use the softkeys to select the **BIAS INTERFACE** test.

Softkey	Function
<b>INCR +</b>	Increments the test number of the Test Menu.
<b>DECR -</b>	Decrements the test number of the Test Menu.

**Step 9.** Press the **EXECUTE - TEST START** softkeys to execute the **BIAS INTERFACE** test.

**NOTE**

Check the settings of S1 and S2 described in the **Step 1**, if the E4980A/E4980AL's LCD displays "Illegal Test Setup".

- Step 10.** Confirm the /RESET LED on the bias interface simulator turns ON.
- Step 11.** Confirm CS0 and CS1 LEDs on the simulator turns ON as the E4980A/E4980AL's output signal is displayed on the LCD (Refer to Figure 4-17).
- Step 12.** Confirm that ADRS1-ADRS6 LEDs on the simulator turn ON in accordance with the hexadecimal number displayed on the LCD. One of the 6 LEDs turns ON in sequence as shown in **Figure 4-17**.
- Step 13.** Confirm that D00-D07 LEDs on the simulator turn ON in accordance with the hexadecimal number displayed on the LCD. One of the 8 LEDs turns ON in sequence as shown in **Figure 4-17**.

Figure 4-17 Bias Current Interface Function Test

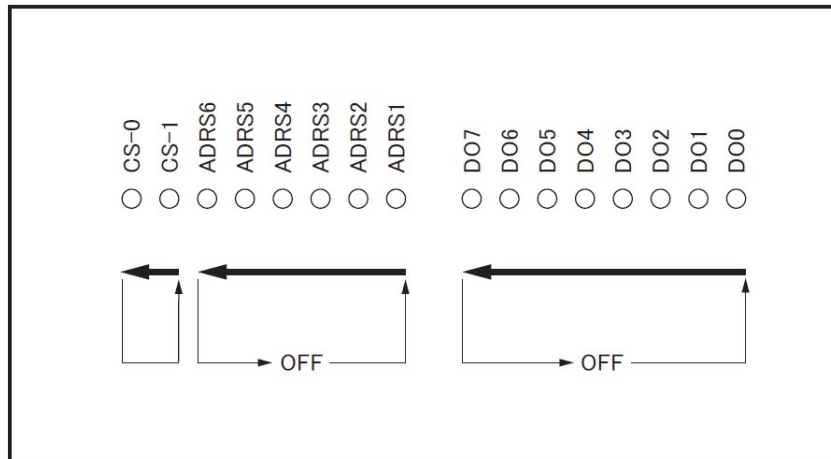

**Step 14.** Confirm that "DI0 TO 7" and "DI8 TO 15" on the LCD of the E4980A/ E4980AL display hexadecimal number "ff".

**Step 15.** Set switches S1 and S2 on the bias interface simulator to '0'. Then confirm that hexadecimal number "0" is displayed by "DI0 TO 7" and "DI8 TO 15".

**NOTE**

The states of S1 (DI0 TO 7) and S2 (DI8 TO 15) are displayed as a hexadecimal number on the E4980A/E4980AL's LCD.

---

**Step 16.** Press the **TEST STOP** softkey.

**NOTE**

Do not execute any SELF TEST except for the Bias Interface Test or the E4980A/E4980AL will become inoperative.

---



## Performance test failure troubleshooting

This section describes the adjustment and troubleshooting procedures used when the E4980A/ E4980AL fails the performance tests. If the performance of the instrument is critical for the test limits and seems to be adjustable, perform first the adjustment(s) related to the failed test. When the test result is far from the tolerance of the test or the performance is not adjustable, isolate the faulty assembly in accordance with the "Performance tests failure troubleshooting procedure".

### Recommended adjustment for performance test failure

**Table 4-11** shows the recommended adjustments when the performance test fails. Select the adjustment program corresponding to the recommended adjustment and perform the adjustment.

Table 4-11

**Recommended adjustment for performance test failure**

Test Num.	First failed test	Recommended adjustment			
		A1	A2	A3	PPMC
1	Frequency Accuracy Test				
2	DC Source Level Accuracy Test				
3	DC Bias Level Accuracy Test				
4	DC Bias V Level Monitor Accuracy Test				
5	DC Bias I Level Monitor Accuracy Test				
6	AC Signal Level Monitor Accuracy Test				
7	AC Signal Level Accuracy Test				
8	Impedance Measurement Accuracy Test				
9	DCR Measurement Accuracy Test				

Adjustment failure troubleshooting

**Table 4-12** represents the relationships between the failed adjustment and probably faulty assembly. Note that this table lists some typical cases. There are possibilities that another assembly may be faulty.

**Table 4-12** Adjustment failure troubleshooting information

Adj Num.	First failed adjustment	Probable faulty board assembly			
		A1	A2	A3	PPMC
1	Null DC offset adjustment		###		
2	Null ADC offset adjustment		###		
3	ADC Linearity adjustment		###	##	
4	DC Bias adjustment		##	###	
5	DC Level V Monitor adjustment		###		
6	DC Level I Monitor adjustment		###		
7	DC Source adjustment		#	###	
8	DCR adjustment		###	#	
9	Impedance adjustment		###	#	
10	AC level Monitor adjustment		###	#	
11	OSC Level adjustment		#	###	

###: Most suspicious assembly

##: Suspicious assembly

#: Possible faulty assembly

Performance test failure troubleshooting

**Table 4-13** represents the relationships between the failed test and probable faulty assembly. If the performance test failure cannot be removed by a proper adjustment, replace the assembly shown in this table.

Note that this table lists some typical cases. There are possibilities that another assembly may be faulty.

**Table 4-13** Performance test failure troubleshooting information

Test Num.	First failed test	Probable faulty board assembly			
		A1	A2	A3	PPMC
1	Frequency Accuracy Test		#	###	
2	DC Source Level Accuracy Test		#	###	
3	DC Bias Level Accuracy Test		#	###	
4	DC Bias V Level Monitor Accuracy Test		###		
5	DC Bias I Level Monitor Accuracy Test		###		
6	AC Signal Level Monitor Accuracy Test		###	#	
7	AC Signal Level Accuracy Test		#	###	
8	Impedance Measurement Accuracy Test		###	#	
9	D CR Measurement Accuracy Test		###	#	

###: Most suspicious assembly

##: Suspicious assembly

#: Possible faulty assembly

Troubleshooting  
Performance test failure troubleshooting

## 5 Replaceable Parts

### Replaceable Parts

The replaceable part information is no longer maintained. Please contact Keysight service center on service related request.

Replaceable Parts  
Replaceable Parts

## 6 Replacement Procedure

This chapter provides procedure for removing and replacing the major assemblies in the E4980A/ E4980AL.

### Replacing an Assembly

The following steps show the sequence for replacing an assembly in a E4980A/ E4980AL Signal Source Analyzer.

1. Identify the faulty group. Refer to **Chapter 4, “Troubleshooting.”**
2. Order a replacement assembly. Refer to **Chapter 5, “Replaceable Parts.”**
3. Replace the faulty assembly and determine what adjustments are necessary. Refer to This chapter and **Chapter 7, “Post-Repair Procedures.”**
4. Perform the necessary adjustments. Refer to **Chapter 3, “Adjustment.”**
5. Perform the necessary performance tests. Refer to **Chapter 2, “Performance Test.”**

#### WARNING

These servicing instructions are for use by qualified personnel only. To avoid electrical shock, do not perform any servicing unless you are qualified to do so.

---

#### WARNING

The opening of covers or removal of parts is likely to expose dangerous voltages. Disconnect the instrument from its power supply.

---

#### CAUTION

Many of the assemblies in this instrument are very susceptible to damage from ESD(electrostatic discharge). Perform the following procedures only at a static-safe workstation and wear a grounding strap.

---

Replacement Procedure  
Required Tools

## Required Tools

The following tools are required for repair of E4980A/ E4980AL.

**Table 6-1 Required Tools**

Assembly	Torque screwdriver				Box torque wrench			
	T6	T8	T10	T20	5.5 mm	7 mm	3/8 in.	5/8 in.
3/4 Rack Module Top								
A3 Analog Daughter Board								
A2 Analog Board								
Front Panel Assembly								
Option Interface								
PPMC PCA								
A1 Mother Board								
Power Supply Assembly								
Base Plate								
Rear Panel Assembly								
FAN Assembly								
GPIB Cable								
Power Inlet Assembly								
PCA E4980 USB								
Binding Post Sgl								
Inverter								
Front Panel, Key Pad, and Key Flex Circuit								
Display Interface								



## 3/4 Rack Module Top Replacement

### Tools Required

- Torque screwdriver, TORX T20

### Removal Procedure

Refer to [Figure 6-1](#), [Figure 6-2](#), [Figure 6-3](#) and for this procedure.

**Step 1.** Disconnect the power cable from the E4980A/ E4980AL.

**Step 2.** Remove the handle, front bumper and rear bumper. (item 1, 2, 3)

#### NOTE

To remove the handle, rotate the handle to a vertical position and pull the arms outwards.

---

**Step 3.** Work the six TORX T20 screws (item 4) loose from the bottom.

**Step 4.** Remove the 3/4 Rack Module Top with the Wind Angle. (item 5)

**Step 5.** Remove the seven VENT BLOCKS (item 6) from the 3/4 Rack Module Bottom.

**Step 6.** Remove the two TORX T20 screws (item 7) fastening the Wind Angle.

**Step 7.** Remove the Wind Angle (item 8) from the 3/4 Rack Module Top.

### Replacement Procedure

**Step 1.** Reverse the order of the removal procedure.

#### NOTE

When you fasten the Wind Angle with the two TORX T20 screws, set screwdriver's torque to 21.1 in-lb.

When you fasten the 3/4 Rack Module Top with the six TORX T20 screws, set screwdriver's torque to 21.1 in-lb.

---

Replacement Procedure  
3/4 Rack Module Top Replacement

Figure 6-1 3/4 Rack Module Top Removal (1 of 3)

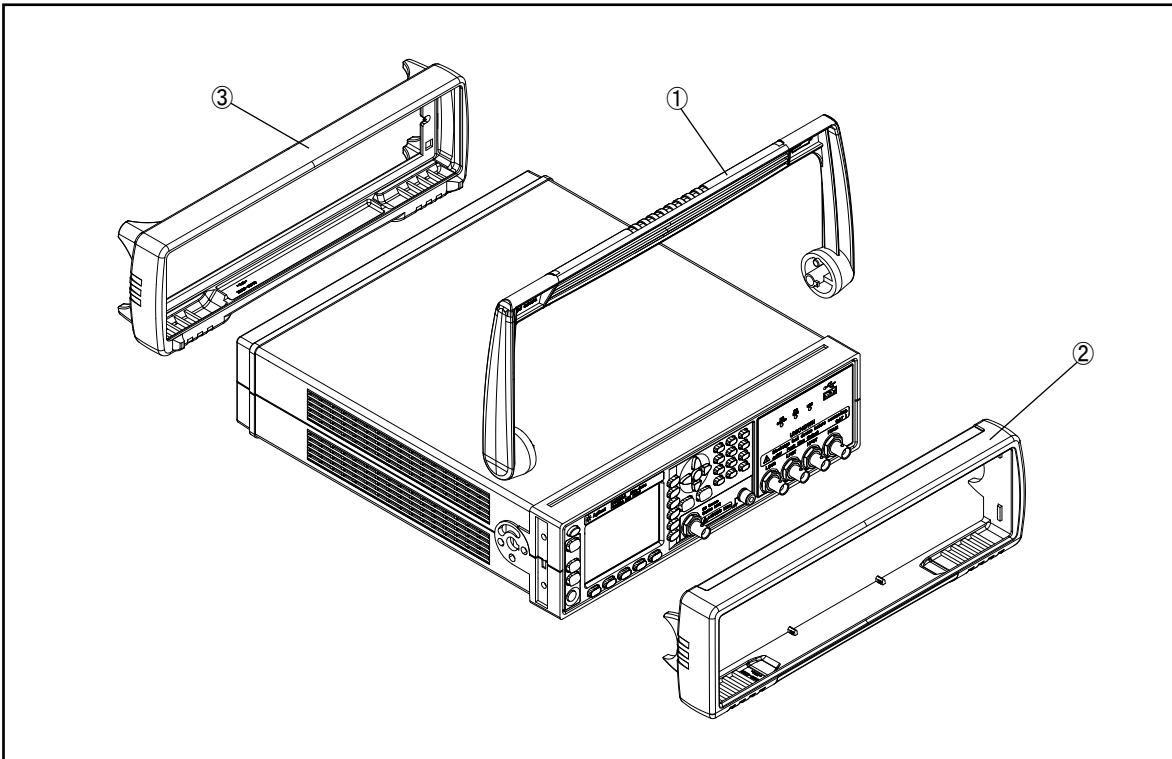

Replacement Procedure  
3/4 Rack Module Top Replacement

Figure 6-2 3/4 Rack Module Top Removal (2 of 3)

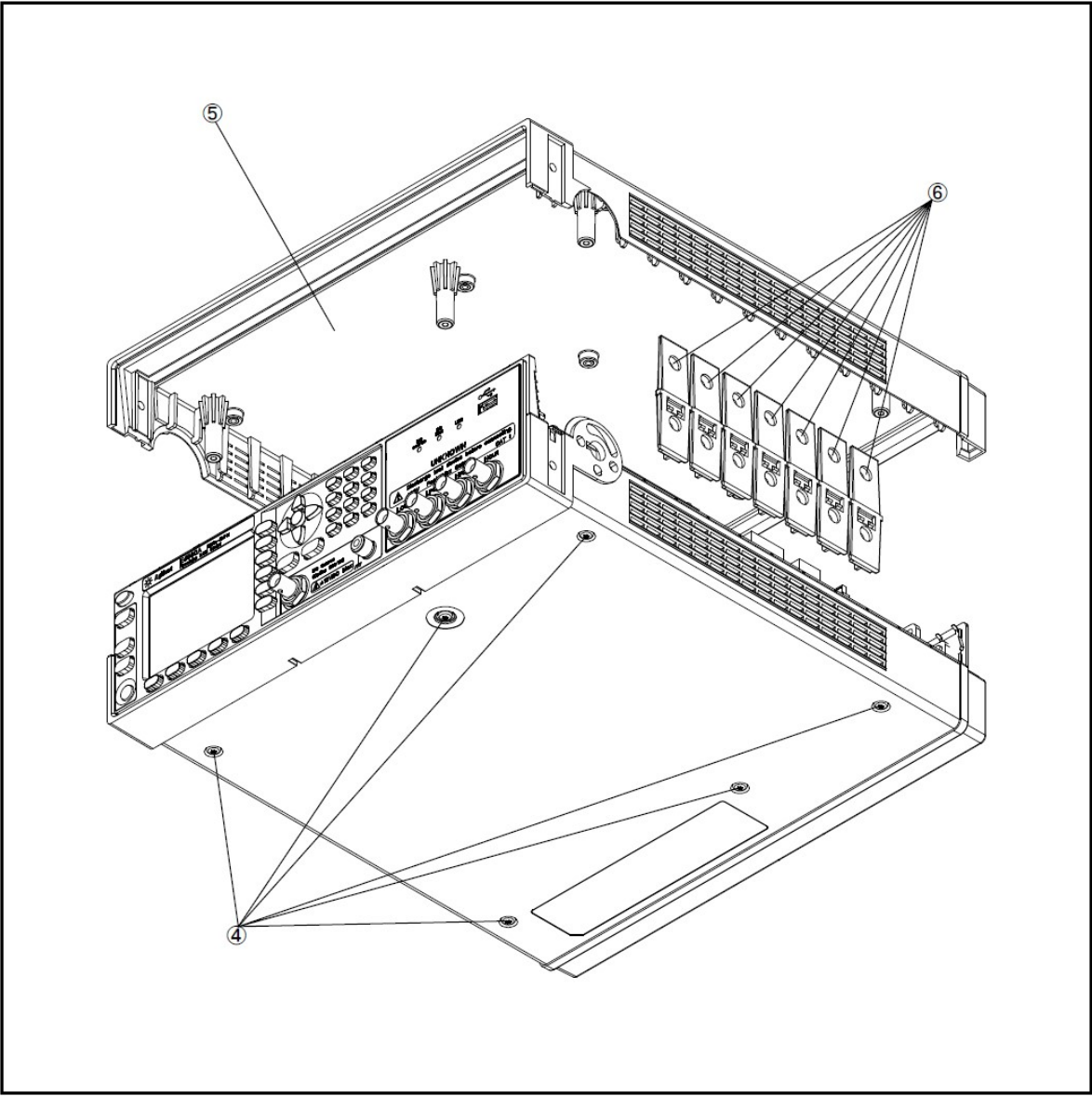

Replacement Procedure  
3/4 Rack Module Top Replacement

Figure 6-3 3/4 Rack Module Top Removal (3 of 3)

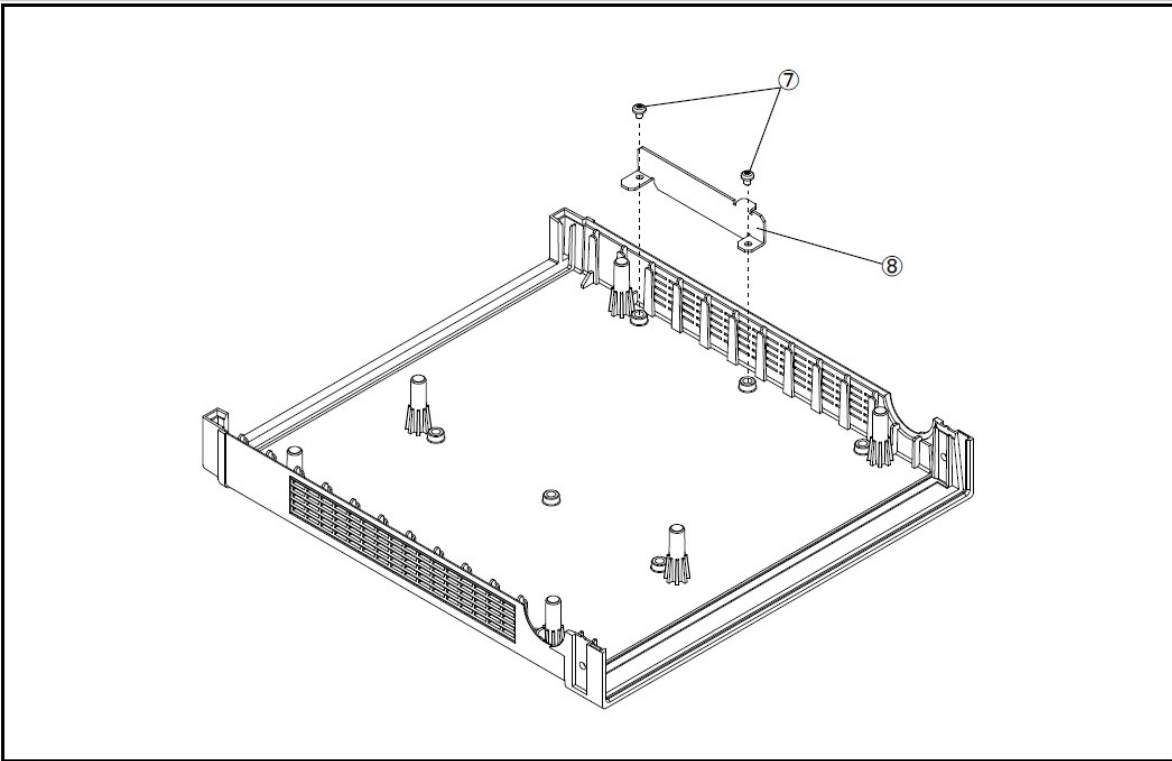

## A3 Analog Daughter Board Replacement

### Tools Required

- Torque screwdriver, TORX T10
- Torque screwdriver, TORX T20

### Removal Procedure

Refer to [Figure 6-4](#) and for this procedure.

- Step 1.** Remove the 3/4 rack module top as described in [“3/4 Rack Module Top Replacement” on page 73](#).
- Step 2.** Disconnect the front USB cable (item 1) from the front panel assembly.
- Step 3.** Disconnect the LCD cable (item 2) from the A1 Mother Board.
- Step 4.** Disconnect the power supply cable (item 3) from the A3 Analog Daughter Board.

#### NOTE

Pull out the power supply cable straight without touching the hook on the cable connector.

---

- Step 5.** Disconnect the two SMB cables (item 4) from the A3 Analog Daughter Board.
- Step 6.** Disconnect the Analog Source Cable (item 5) from the A3 Analog Daughter Board.
- Step 7.** Remove the four TORX T10 screws (item 6) fastening the A3 Analog Daughter Board.
- Step 8.** Remove the A3 Analog Daughter Board.

### Replacement Procedure

- Step 1.** Reverse the order of the removal procedure.

#### NOTE

When you replace the A3 Analog Daughter Board, stick the Foot Bumper (item 7) to the backside of the board as location of sub-figure in [Figure 6-4](#).

When you fasten the A3 Analog Daughter Board with the four TORX T10 screws, set screwdriver's torque to 8.7 in-lb.

When you connect the LCD Cable to the A1 Mother Board, make sure the LCD Cable lies beneath the Analog Source Cable.

---

Replacement Procedure  
A3 Analog Daughter Board Replacement

Figure 6-4 A3 Analog Daughter Board Removal

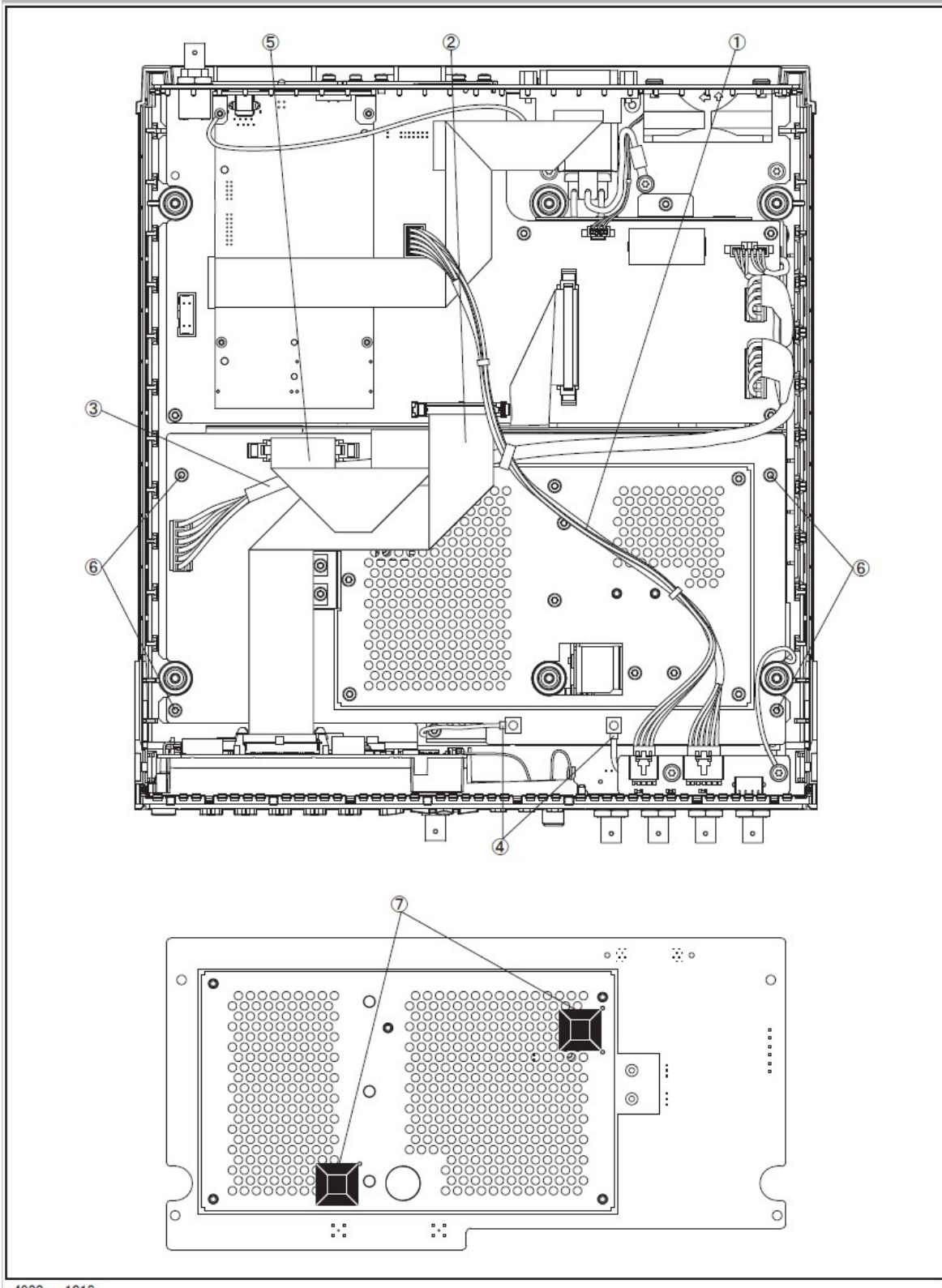

## A2 Analog Board Replacement

### Tools Required

- Torque screwdriver, TORX T10
- Torque screwdriver, TORX T20
- Box torque wrench, 7 mm
- Box torque wrench, 5/8 inch

### Removal Procedure

Refer to Figure 6-5 and for this procedure.

- Step 1.** Remove the 3/4 rack module top as described in “[3/4 Rack Module Top Replacement](#)” on page 73.
- Step 2.** Remove the A3 Analog Daughter Board as described in “[A3 Analog Daughter Board Replacement](#)” on page 77.
- Step 3.** Disconnect the Mother-Analog Cable (item 1) from the A2 Analog Board.
- Step 4.** Disconnect the Analog Source Cable (item 2) from the A2 Analog Board.
- Step 5.** Remove the four 7 mm Standoff (item 3) from the A2 Analog Board.
- Step 6.** Remove the TORX T20 screw (item 4) from the PCA E4980 USB. Then, Disconnect the ground cable from the PCA E4980 USB.
- Step 7.** Lift the A2 Analog Board and front panel toward upside.
- Step 8.** Remove the five 5/8 inch nuts and washers (item 5) fastening the BNC connector.
- Step 9.** Remove the A2 Analog Board from Front Panel.
- Step 10.** Disconnect the two SMB cables (item 6) from the A2 Analog Board.

### Replacement Procedure

- Step 1.** Reverse the order of the removal procedure.

#### NOTE

When you fasten the A2 Analog Board with the five 5/8 inch nuts and washers, set box torque wrench's torque to 17.4 in-lb.

When you fasten the A2 Analog Board with the four 7 mm Standoff, set box torque wrench's torque to 8.7 in-lb.

---

Replacement Procedure  
A2 Analog Board Replacement

Figure 6-5 A2 Analog Board Removal

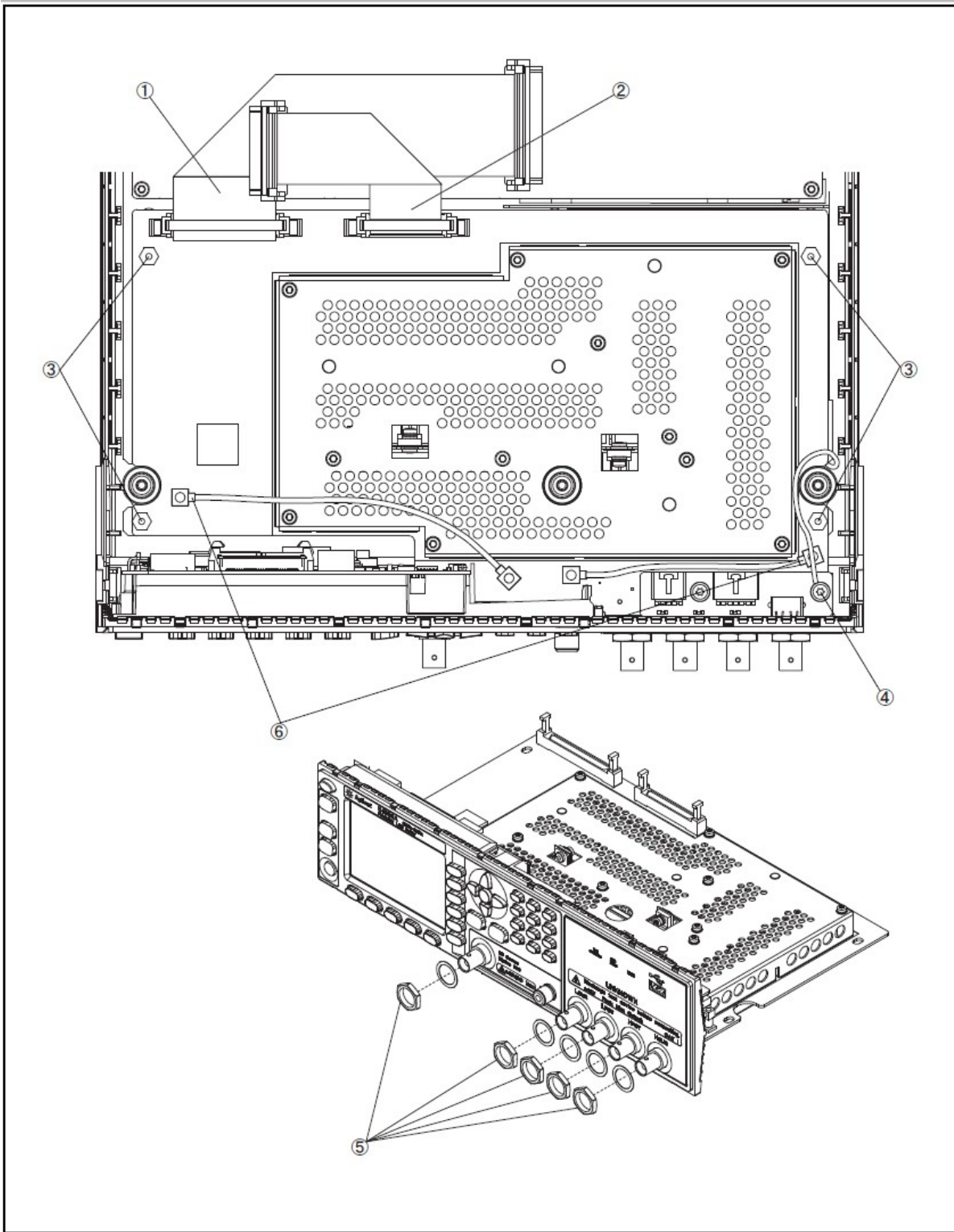



## Front Panel Assembly Removal

### Tools required

- Torque screwdriver, TORX T10
- Torque screwdriver, TORX T20
- Box torque wrench, 7 mm
- Box torque wrench, 5/8 inch

### Removal Procedure

The Front Panel Assembly removal process is same as A2 Analog Board removal process. Refer to removal procedure of the **“A2 Analog Board Replacement” on page 79.**

### Replacement Procedure

The Front Panel Assembly replacement process is reverse order of the A2 Analog Board removal process. Refer to removal procedure of the **“A2 Analog Board Replacement” on page 79.**

## Option Interface Replacement

### Tools Required

- Torque screwdriver, TORX T10

### Removal Procedure

Refer to **Figure 6-6** for this procedure.

- Step 1.** Remove the two TORX T10 screws (item 1) fastening the Option Interface.
- Step 2.** Pulls the Option Interface carefully.
- Step 3.** Carefully disconnect the flat cable (item 2) of Option Interface side. Release the cable's connector by pressing the locking hooks at the sides of the connector.
- Step 4.** Remove the two TORX T10 screws (item 3) fastening the option panel.
- Step 5.** Remove the option panel from the option interface board.
- Step 6.** Disconnect the flat cable from the A1 Mother Board connector (item 4).

### Replacement Procedure

- Step 1.** Reverse the order of the removal procedure.

#### NOTE

When you fasten the option panel with the two TORX T10 screws, set screwdriver's torque to 8.7 in-lb.

When you fasten the interface card with the two TORX T10 screws, set screwdriver's torque to 7 in-lb.

---

Figure 6-6 Option Interface Removal

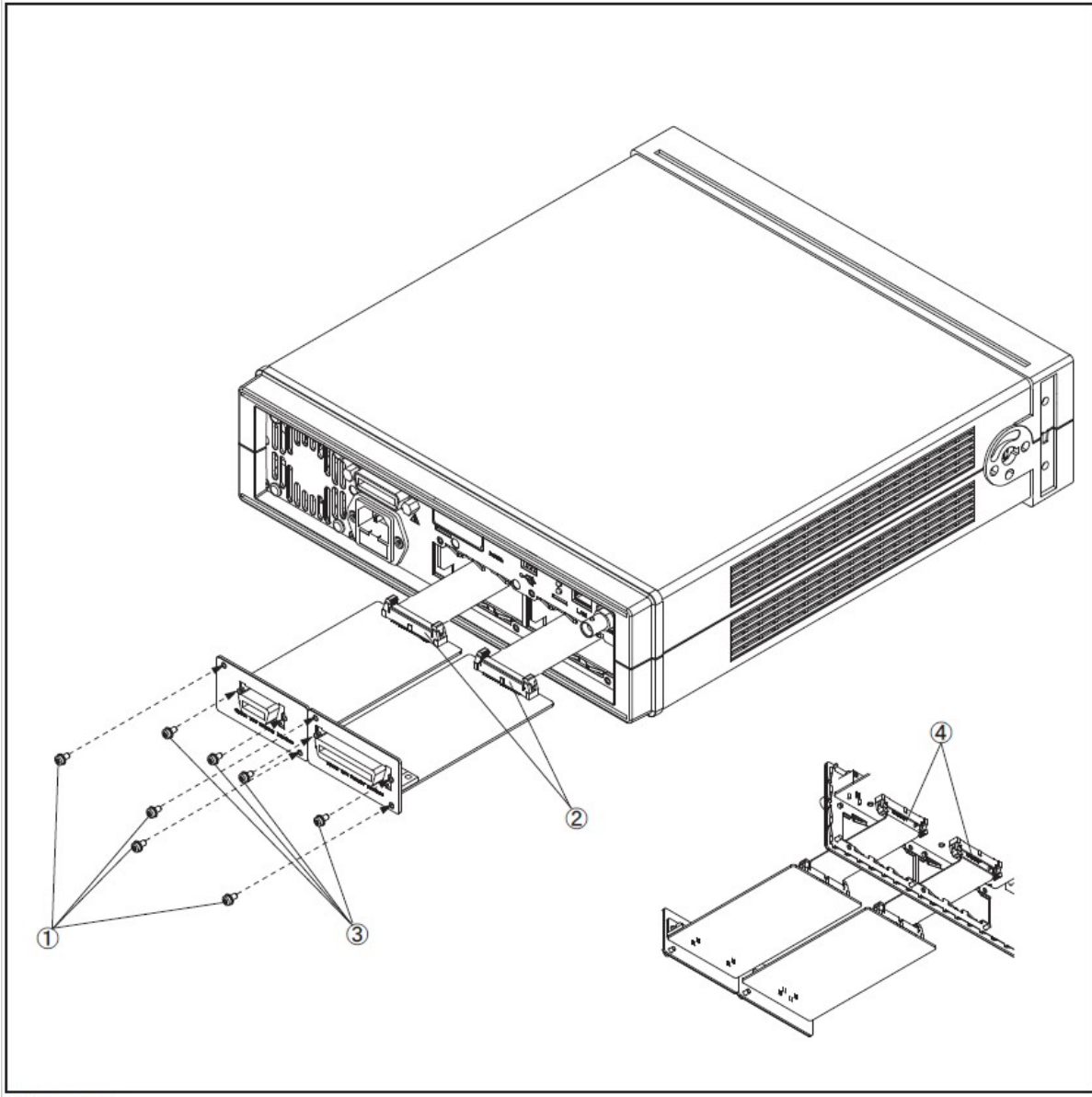

## PPMC PCA Replacement

### Tools Required

- Torque screwdriver, TORX T20
- Torque screwdriver, TORX T8

### Removal Procedure

Refer to **Figure 6-7** for this procedure.

- Step 1.** Remove the 3/4 rack module top as described in **“3/4 Rack Module Top Replacement” on page 73**.
- Step 2.** Remove the four TORX T8 screws (item 1) fastening the PPMC PCA.
- Step 3.** Remove the Angle CPU (item 2) from the PPMC PCA.
- Step 4.** Disconnect the ground cable (item 3).
- Step 5.** Carefully disconnect the PPMC PCA from A1 Mother Board.
- Step 6.** Carefully disconnect the GPIB cable (item 4) from PPMC PCA.
- Step 7.** Remove the USB gasket (item 5) from the PPMC PCA.

### Replacement Procedure

- Step 1.** Reverse the order of the removal procedure.

#### NOTE

When you fasten the PPMC PCA with the four TORX T8 screws, set screwdriver's torque to 3 in-lb.

---

Replacement Procedure  
PPMC PCA Replacement

Figure 6-7 PPMC PCA Removal

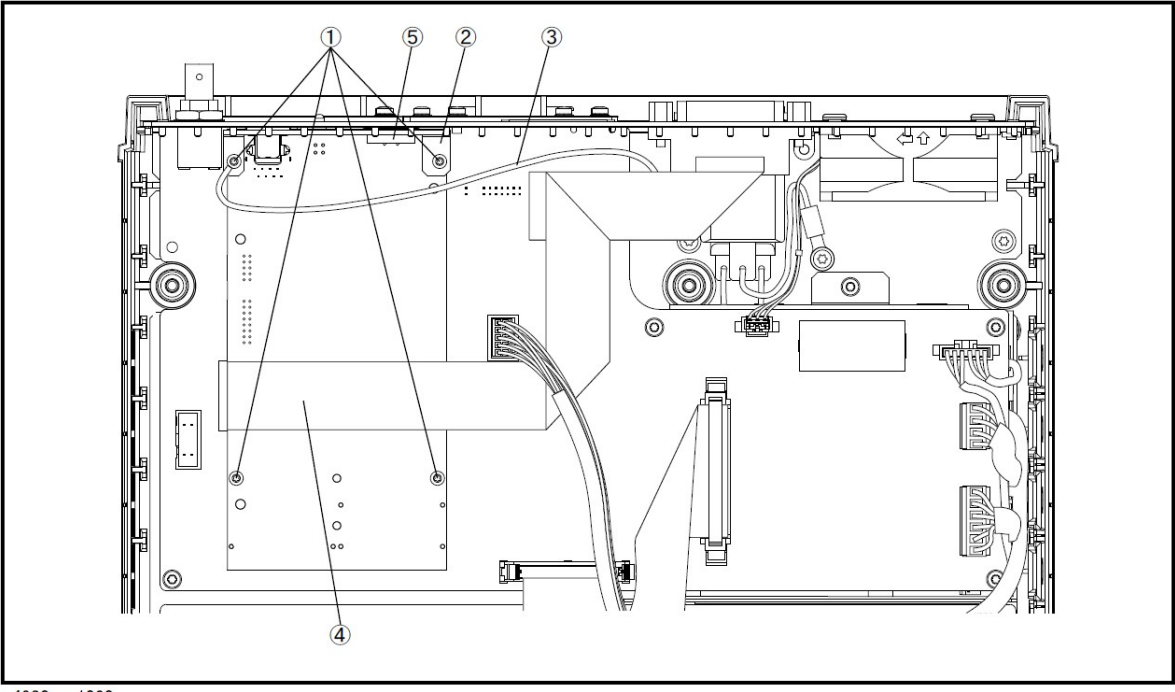

## A1 Mother Board Replacement

### Tools Required

- Torque screwdriver, TORX T20
- Torque screwdriver, TORX T8
- Torque screwdriver, TORX T10
- Box torque wrench, 5/8 inch

### Removal Procedure

Refer to **Figure 6-8** for this procedure.

- Step 1.** Remove the 3/4 rack module top as described in “**3/4 Rack Module Top Replacement**” on page 73.
- Step 2.** Remove the PPMC PCA as described in “**PPMC PCA Replacement**” on page 84.
- Step 3.** Disconnect the Mother-Analog cable (item 1) from A1 Mother Board.
- Step 4.** Disconnect the front USB cable (item 2) from A1 Mother Board.
- Step 5.** Disconnect the cable power control (item 3) from A1 Mother Board.
- Step 6.** Disconnect the power supply cables (item 4) from A1 Mother Board.

#### NOTE

Pull out the power supply cables straight without touching the hook on the cable connector.

---

- Step 7.** Disconnect the LCD cable (item 5) from Front Panel Assembly.
- Step 8.** Disconnect the fan cable (item 6) from FAN Assembly.
- Step 9.** Remove the 5/8 inch nut and washer (item 7) fastening the BNC connector.
- Step 10.** Remove the five TORX T10 screws (item 8) from the A1 Mother Board.
- Step 11.** Remove the A1 Mother Board toward front side.

### Replacement Procedure

- Step 1.** Reverse the order of the removal procedure.

#### NOTE

When you fasten the BNC connector with the 5/8 inch nut and washer, set box torque wrench's torque to 17.4 in-lb.

When you fasten the A1 Mother Board with the five TORX T10 screws, set screwdriver's torque to 8.7 in-lb for left-under screw of item 8 in the Figure 6-8, and set screwdriver's torque to 4.35 in-lb for other screws.

When you connect the LCD Cable to the A1 Mother Board, make sure the LCD Cable is at the bottom of the Analog Source Cable.

---

Replacement Procedure  
A1 Mother Board Replacement

Figure 6-8 A1 Mother Board Replacement

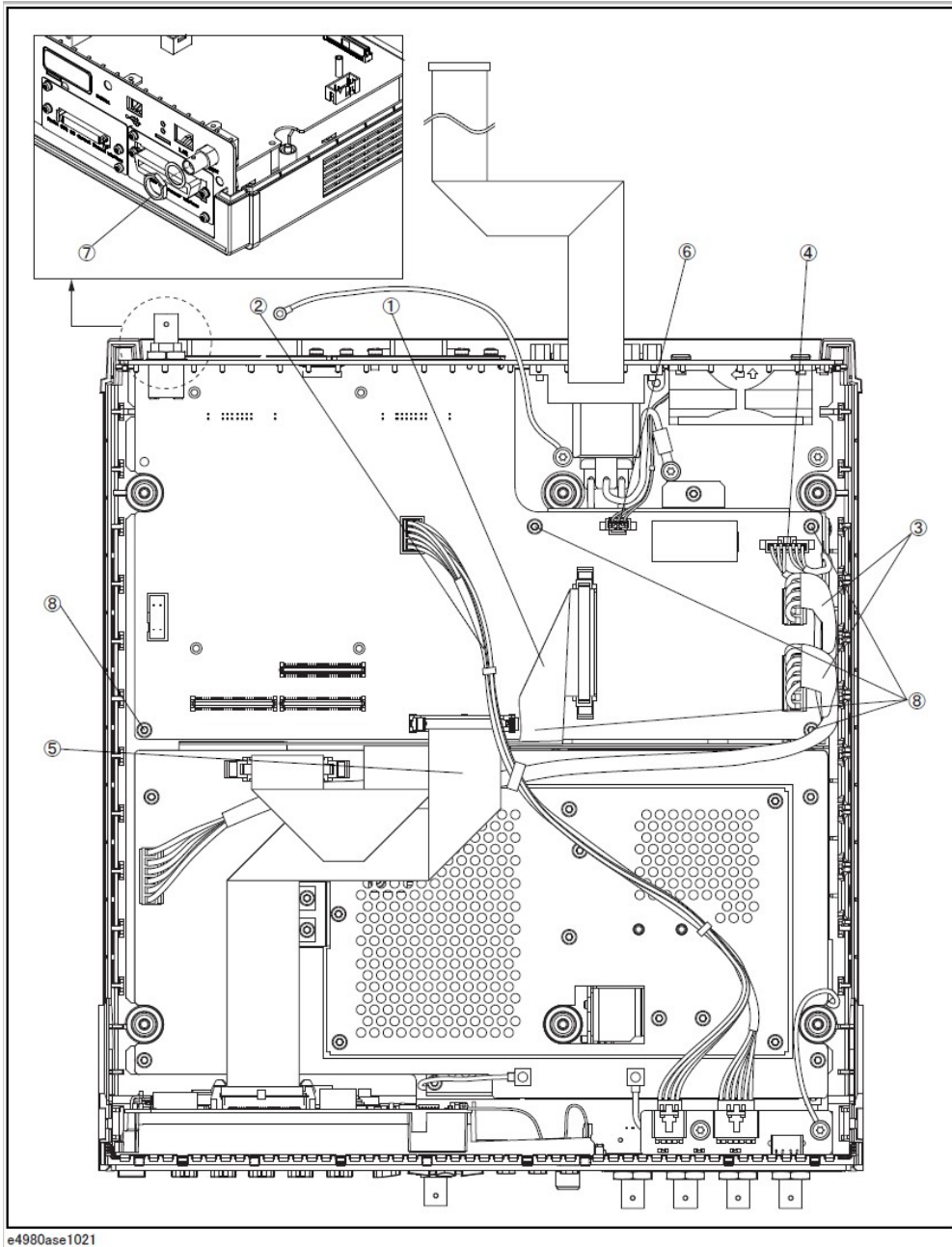

## Power Supply Assembly Replacement

### Tools Required

- Torque screwdriver, TORX T20
- Torque screwdriver, TORX T8
- Torque screwdriver, TORX T10
- Box torque wrench, 5/8 inch
- Box torque wrench, 5.5 mm

### Removal Procedure

Refer to **Figure 6-9** for this procedure.

- Step 1.** Remove the 3/4 rack module top as described in “**3/4 Rack Module Top Replacement**” on page 73.
- Step 2.** Remove the PPMC PCA as described in “**PPMC PCA Replacement**” on page 84.
- Step 3.** Remove the A1 Mother Board as described in “**A1 Mother Board Replacement**” on page 86.
- Step 4.** Disconnect the cable of the inlet (item 1) from the Power Supply Assembly.
- Step 5.** Remove the four 5.5 mm Standoff (item 2).
- Step 6.** Remove the TORX T10 screw (item 3) fastening the CPU cover.
- Step 7.** Remove the CPU cover (item 4).
- Step 8.** Remove the Power Supply Assembly with the cable power control.
- Step 9.** Disconnect the cable power control (item 5) from the Power Supply Assembly.

#### NOTE

Do not pull out the power cable (P/N : E4980-61601) from the Power Supply Assembly when you detach the Power Supply Assembly. There is a possibility that the Power Supply Assembly could break when the power cable is forcibly pulled out. (Refer to sub-figure in **Figure 6-9**)

---



## Replacement Procedure

**Step 1.** Reverse the order of the removal procedure.

### NOTE

When you fasten the CPU cover with the TORX T10 screw, set screwdriver's torque to 8.7 in-lb.

When you fasten the Power Supply Assembly with the 5.5 mm Standoff, set box torque wrench's torque to 7 in-lb.

When you replace the Power Supply Assembly with a new one, use a new power cable (P/N : E4980-61601).Note

---

Figure 6-9 Power Supply Assembly Removal

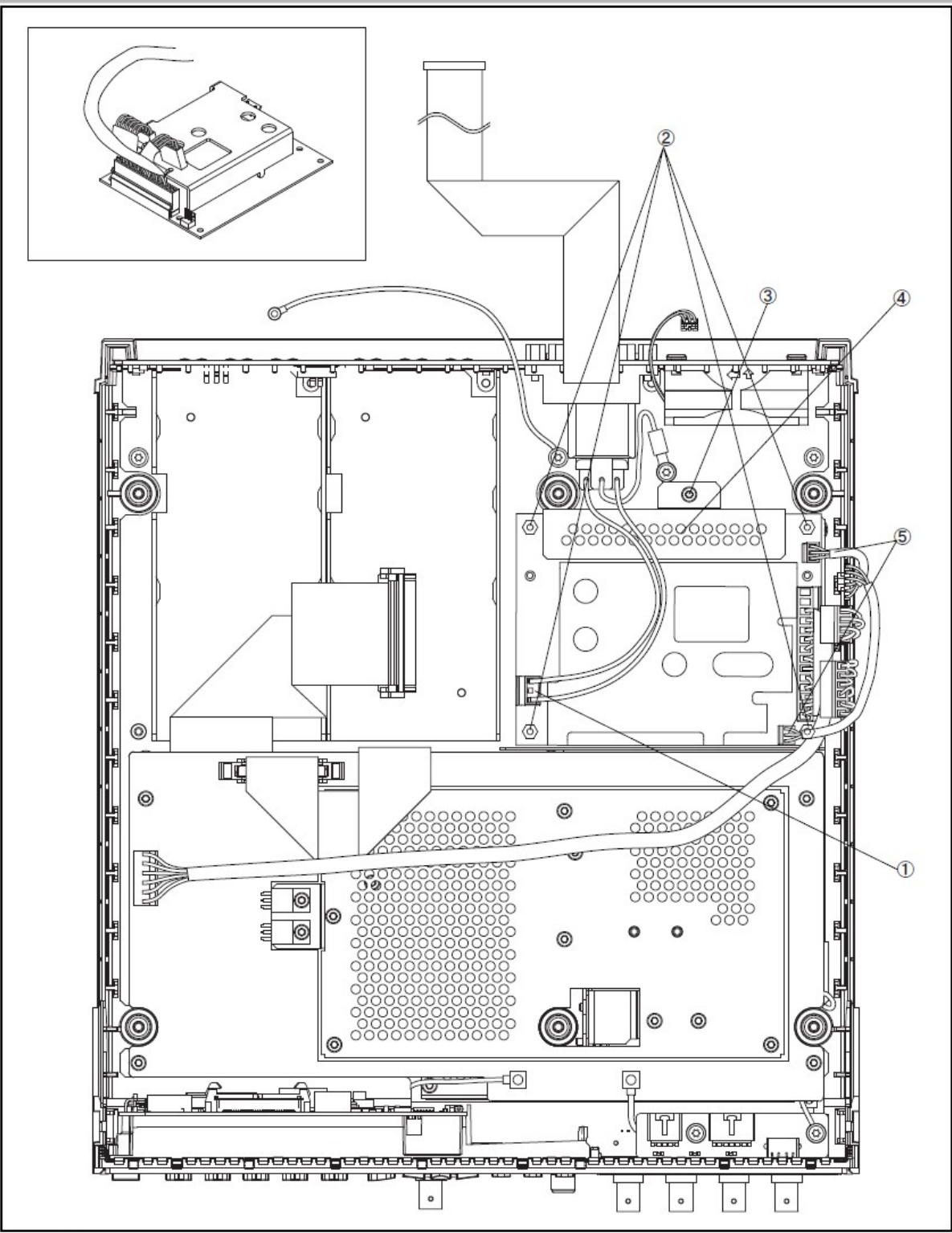

## Base Plate Replacement

### Tools Required

- Torque screwdriver, TORX T20
- Torque screwdriver, TORX T8
- Torque screwdriver, TORX T10
- Box torque wrench, 5/8 inch
- Box torque wrench, 5.5 mm
- Box torque wrench, 7 mm

### Removal Procedure

Refer to [Figure 6-10](#) for this procedure.

- Step 1.** Remove the Option Interface as described in [“Option Interface Replacement” on page 82](#).
- Step 2.** Remove the 3/4 Rack Module Top as described in [“3/4 Rack Module Top Replacement” on page 73](#).
- Step 3.** Remove the A3 Analog Daughter Board as described in [“A3 Analog Daughter Board Replacement” on page 77](#).
- Step 4.** Remove the A2 Analog Board as described in [“A2 Analog Board Replacement” on page 79](#).
- Step 5.** Remove the two TORX T10 screws (item 1) fastening the Shield Angle.
- Step 6.** Remove the Shield Angle (item 2) from the Base Plate.
- Step 7.** Remove the PPMC PCA as described in [“PPMC PCA Replacement” on page 84](#).
- Step 8.** Remove the A1 Mother Board as described in [“A1 Mother Board Replacement” on page 86](#).
- Step 9.** Remove the Power Supply Assembly as described in [“Power Supply Assembly Replacement” on page 88](#).
- Step 10.** Remove the seven TORX T20 screws (item 3) fastening the Base Plate.
- Step 11.** Remove the two TORX T20 screws (item 4) fastening the Base Plate and the ground cables. Then, remove the ground cables (item 5).
- Step 12.** Remove the Rack Module Bottom from the Base Plate.
- Step 13.** Remove the Rear Panel as described from [Step 9](#) to [Step 11](#) in [“Rear Panel Assembly Replacement” on page 94](#).
- Step 14.** Remove the Base Plate from the Rear Panel.

## Replacement Procedure

**Step 1.** Reverse the order of the removal procedure.

### NOTE

When you fasten the ground cable and the Base Plate with the two TORX T20 screws, set screwdriver's torque to 21.1 in-lb.

When you fasten the Base Plate with the seven TORX T20 screws, set screwdriver's torque to 21.1 in-lb.

When you fasten the Shield Angle with the two TORX T10 screws, set screwdriver's torque to 8.7 in-lb.

---

Figure 6-10 Base Plate Board Removal

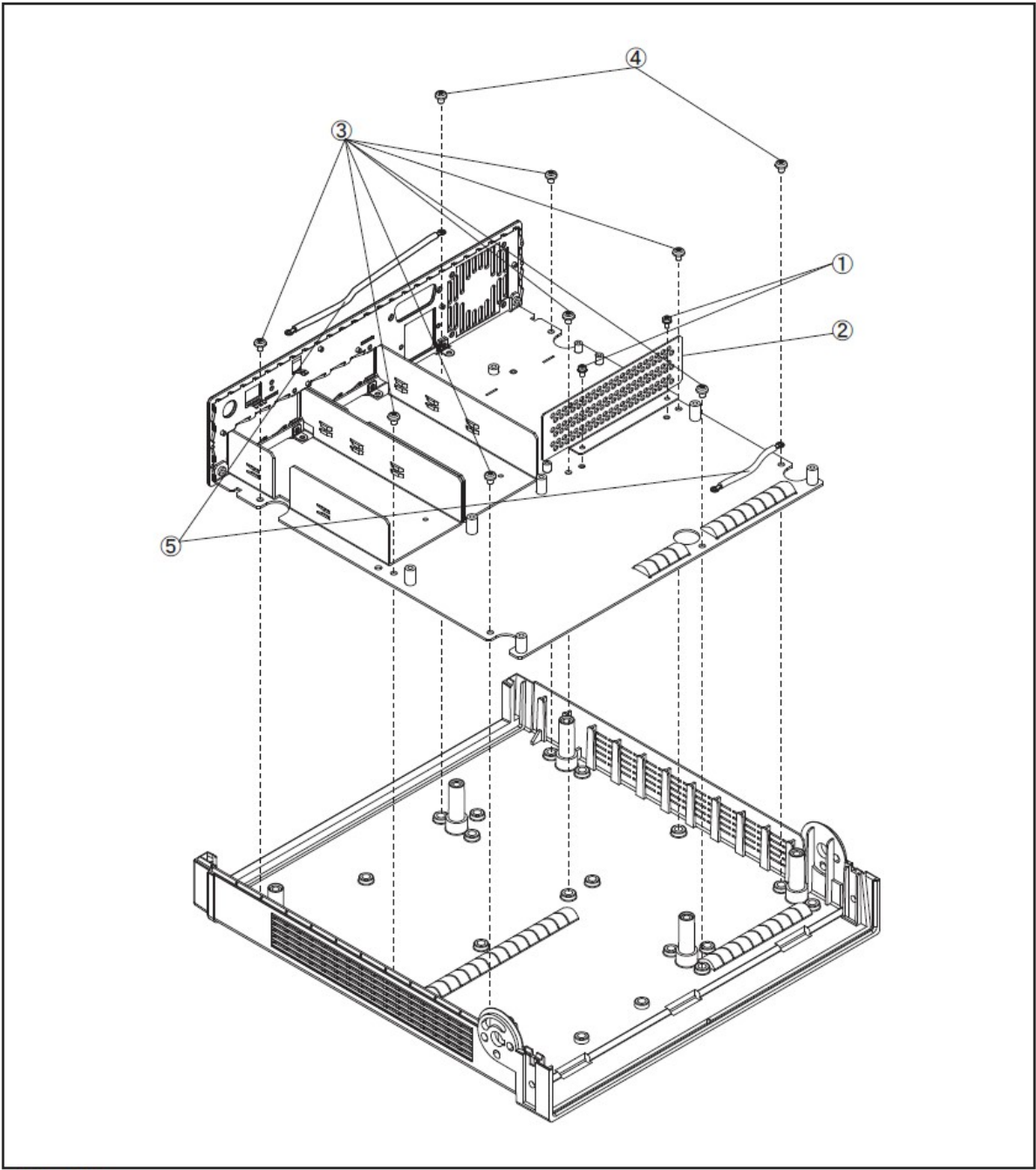

## Rear Panel Assembly Replacement

### Tools Required

- Torque screwdriver, TORX T20
- Torque screwdriver, TORX T8
- Torque screwdriver, TORX T10
- Box torque wrench, 5/8 inch
- Box torque wrench, 5.5 mm
- Box torque wrench, 7 mm

### Removal Procedure

Refer to **Figure 6-11** for this procedure.

- Step 1.** Remove the Option Interface as described in **“Option Interface Replacement” on page 82.**
- Step 2.** Remove the 3/4 Rack Module Top as described in **“3/4 Rack Module Top Replacement” on page 73.**
- Step 3.** Remove the A3 Analog Daughter Board as described in **“A3 Analog Daughter Board Replacement” on page 77.**
- Step 4.** Remove the A2 Analog Board as described in **“A2 Analog Board Replacement” on page 79.**
- Step 5.** Remove the PPMC PCA as described in **“PPMC PCA Replacement” on page 84.**
- Step 6.** Remove the A1 Mother Board as described in **“A1 Mother Board Replacement” on page 86.**
- Step 7.** Remove the Power Supply Assembly as described in **“Power Supply Assembly Replacement” on page 88.**
- Step 8.** Remove the bottom clamshell as described from **Step 10 to Step 12** in **“Base Plate Replacement” on page 91.**
- Step 9.** Remove the one TORX T20 screw (item 1) fastening the ground cable.
- Step 10.** Remove the five TORX T10 screws (item 2) fastening the Rear Panel Assembly.
- Step 11.** Remove the Rear Panel Assembly from the Base Plate.

Replacement Procedure

**Step 1.** Reverse the order of the removal procedure.

**NOTE**

When you fasten the Rear Panel with the five TORX T10 screws, set screwdriver's torque to 8.7 in-lb.

When you fasten the ground cable with the TORX T20 screw, set screwdriver's torque to 21.1 in-lb.

Figure 6-11 Rear Panel Assembly Removal

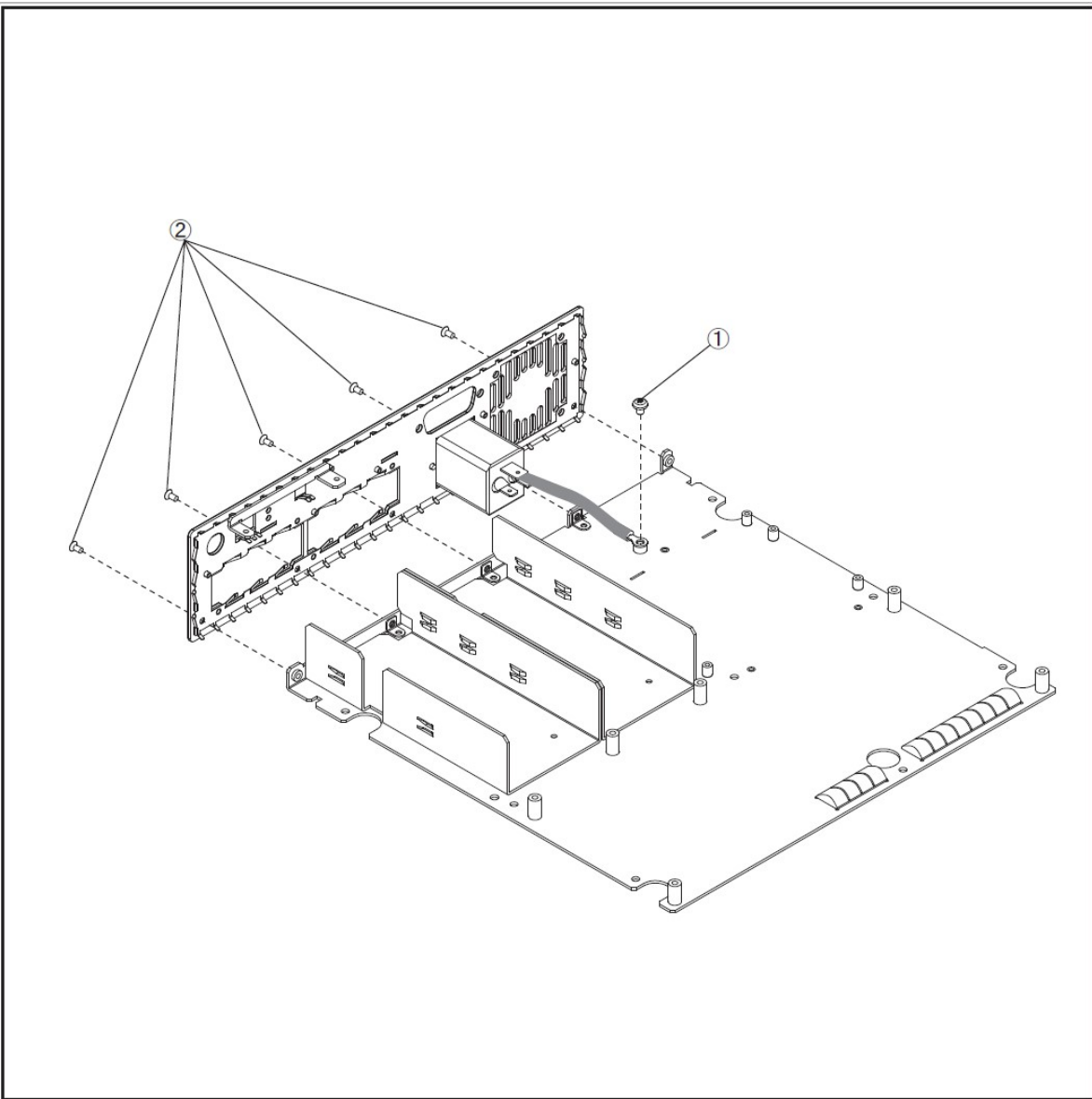

## FAN Assembly Replacement

### Tools Required

- Torque screwdriver, TORX T20

### Removal Procedure

Refer to **Figure 6-12** for this procedure.

- Step 1.** Remove the 3/4 Rack Module Top as described in **“3/4 Rack Module Top Replacement” on page 73**.
- Step 2.** Disconnect the connector of the fan cable on the A1 Mother Board (item 1) from Fan Assembly.
- Step 3.** Push the four Rivets (item 2) from the inside, then, remove the four Rivets fastening the Fan Assembly.

#### NOTE

If you can not push the rivets out easily, push the rivets out using a flat-edge driver.

---

- Step 4.** Remove the Fan Assembly (item 3) from the Rear Panel.

### Replacement Procedure

- Step 1.** Reverse the order of the removal procedure.

#### NOTE

When you replace the Fan Assembly, use new rivets.

---



Figure 6-12 FAN Assembly Removal

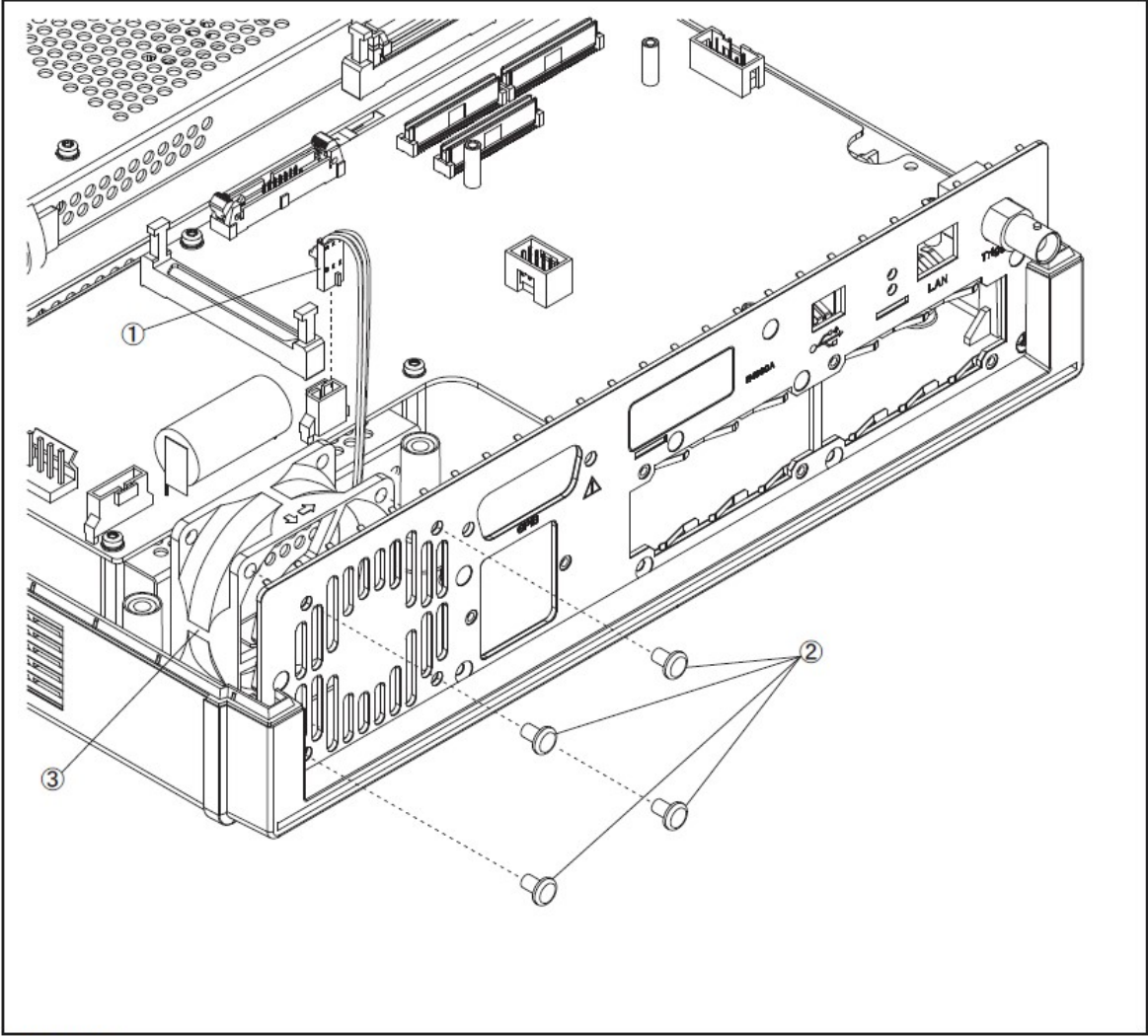

## GPIB Cable Replacement

### Tools Required

- Torque screwdriver, TORX T20
- Box torque wrench, 7 mm

### Removal Procedure

Refer to **Figure 6-13** for this procedure.

- Step 1.** Remove the 3/4 Rack Module Top as described in **“3/4 Rack Module Top Replacement”** on page 73.
- Step 2.** Disconnect the GPIB Cable connector (item 1) from PPM PCA card.
- Step 3.** Remove the two 7mm standoff (item 2) fastening the GPIB cable.
- Step 4.** Remove the GPIB Cable (item 3) from the Rear Panel Assembly.

### Replacement Procedure

- Step 1.** Reverse the order of the removal procedure.

#### NOTE

When you fasten the GPIB Cable with the two 7 mm standoff, set box torque wrench's torque to 8.7 in-lb.

---

Figure 6-13 GPIB Removal

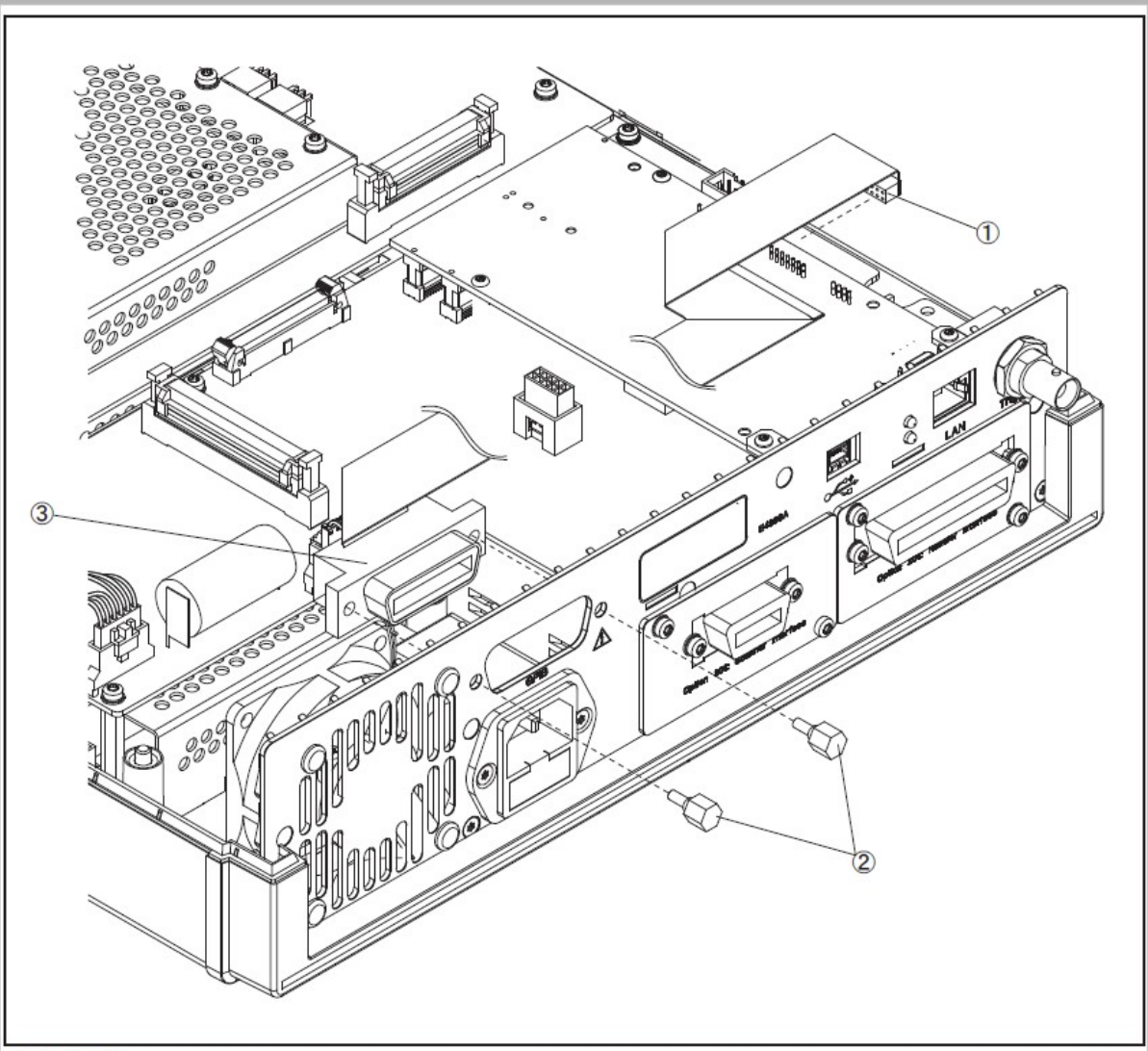

## Power Inlet Assembly Replacement

### Tools Required

- Torque screwdriver, TORX T20
- Torque screwdriver, TORX T8
- Torque screwdriver, TORX T10
- Box torque wrench, 5/8 inch

### Removal Procedure

Refer to **Figure 6-14** for this procedure.

- Step 1.** Remove the 3/4 Rack Module Top as described in **“3/4 Rack Module Top Replacement” on page 73.**
- Step 2.** Remove the PPMC PCA as described in **“PPMC PCA Replacement” on page 84.**
- Step 3.** Remove the A1 Mother Board as described in **“A1 Mother Board Replacement” on page 86.**
- Step 4.** Disconnect the power cable connector (item 1) from the Power Supply Assembly.
- Step 5.** Remove the TORX T20 screw (item 2) fastening the ground cable.
- Step 6.** Remove the two TORX T10 screws (item 3) fastening the Inlet Assembly.
- Step 7.** Remove the Inlet Assembly (item 4) from the Rear Panel.
- Step 8.** Detach the fuse box (item 5) from the original Inlet Assembly and remove the fuse (item 6 ).

### Replacement Procedure

- Step 1.** Reverse the order of the removal procedure.

#### NOTE

When you fasten the ground cable with the TORX T20 screw, set screwdriver's torque to 21.1 in-lb.

When you fasten the Inlet Assembly with the two TORX T10 screws, set screwdriver's torque to 4.5 in-lb.

Do not forget to insert the fuse in the new Inlet Assembly.

---

Figure 6-14 POWER INLET Assembly Removal

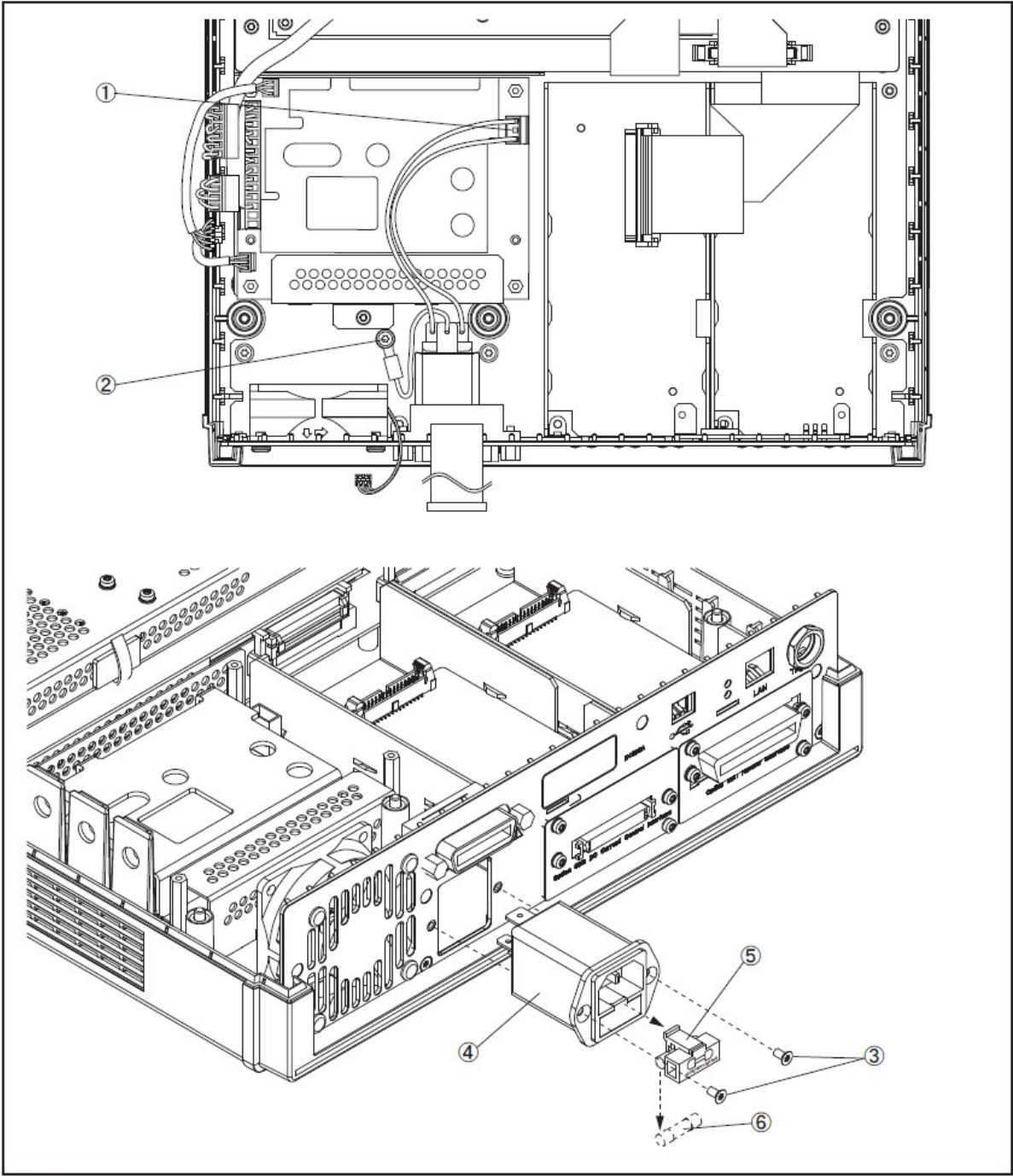

## PCA E4980 USB Replacement

### Tools Required

- Torque screwdriver, TORX T20

### Removal Procedure

Refer to **Figure 6-15** for this procedure.

- Step 1.** Remove the 3/4 Rack Module Top as described in **“3/4 Rack Module Top Replacement”** on page 73.
- Step 2.** Disconnect the Front USB Cable (item 1) from PCA E4980 USB.
- Step 3.** Remove the two TORX T20 screws (item 2) fastening the PCA E4980 USB and the ground cable.
- Step 4.** Remove the PCA E4980 USB (item 3) from the Front Panel Assembly.

### Replacement Procedure

- Step 1.** Reverse the order of the removal procedure.

#### NOTE

When you fasten the PCA E4980 USB and the ground cable with the two TORX T20 screws, set screwdriver's torque to 14 in-lb.

Figure 6-15 PCA E4980 USB Removal

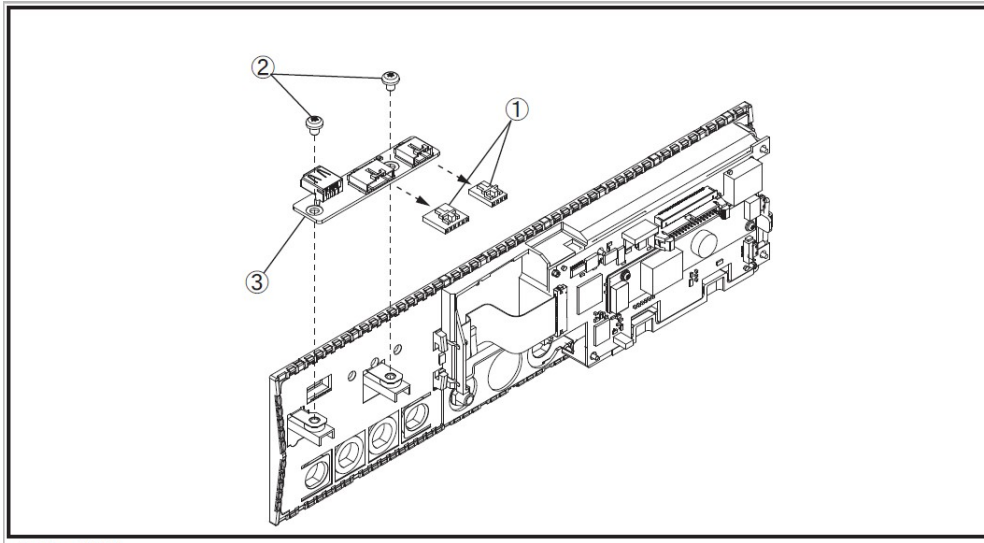

## Binding Post Sgl Replacement

### Tools Required

- Torque screwdriver, TORX T10
- Torque screwdriver, TORX T20
- Box torque wrench, 7 mm
- Box torque wrench, 5/8 inch
- Box torque wrench, 3/8 inch

### Removal Procedure

Refer to **Figure 6-16** for this procedure.

- Step 1.** Remove the 3/4 Rack Module Top as described in **“3/4 Rack Module Top Replacement” on page 73.**
- Step 2.** Remove the A3 Analog Daughter Board as described in **“A3 Analog Daughter Board Replacement” on page 77.**
- Step 3.** Remove the A2 Analog Board as described in **“A2 Analog Board Replacement” on page 79.**
- Step 4.** Remove the Front Panel as described in **“Front Panel Assembly Removal” on page 81.**
- Step 5.** Remove the 3/8 inch nut (item 1) and washer (item 2) fastening the Binding Post Sgl.
- Step 6.** Slide the Binding Post Sgl (item 3) from the Front Panel Assembly.

### Replacement Procedure

- Step 1.** Reverse the order of the removal procedure.

#### NOTE

When you fasten the Binding Post Sgl with the 3/8 inch nut and washer, set box torque wrench's torque to 17.4 in-lb.

---

Figure 6-16 Binding Post Sgl Removal

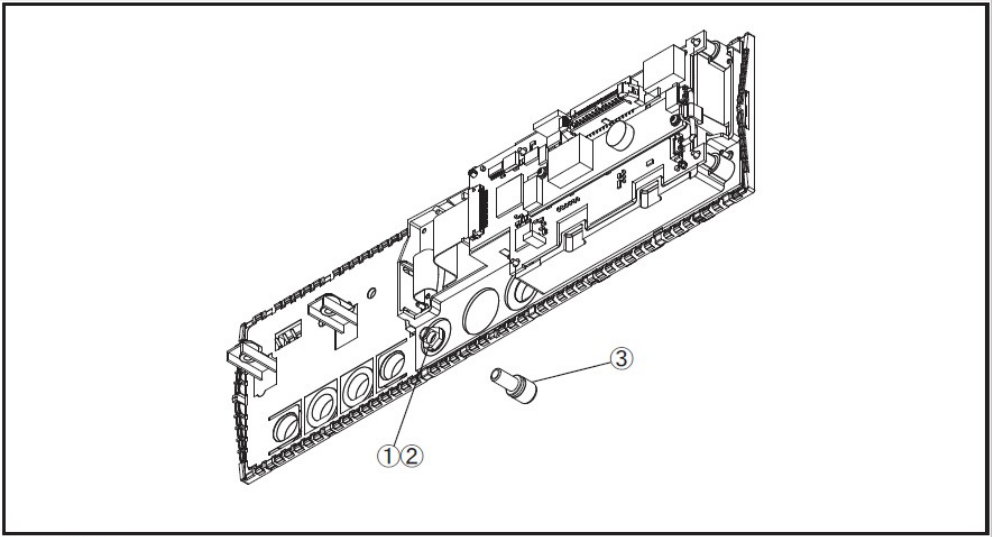



## Inverter Replacement

### Tools Required

- Torque screwdriver, TORX T10
- Torque screwdriver, TORX T20
- Torque screwdriver, TORX T6
- Box torque wrench, 7 mm
- Box torque wrench, 5/8 inch

### Removal Procedure

Refer to **Figure 6-17** for this procedure.

- Step 1.** Remove the 3/4 Rack Module Top as described in “**3/4 Rack Module Top Replacement**” on page 73.
- Step 2.** Remove the A3 Analog Daughter Board as described in “**A3 Analog Daughter Board Replacement**” on page 77.
- Step 3.** Remove the A2 Analog Board as described in “**A2 Analog Board Replacement**” on page 79.
- Step 4.** Remove the Front Panel Assembly as described in “**Front Panel Assembly Removal**” on page 81.
- Step 5.** Disconnect the display cable (item 1) from the Inverter.
- Step 6.** Release the Cable Assy from the clip (item 2) on the Front Panel Assembly.
- Step 7.** Disconnect the Cable Assy (item 3) from the Front Panel Assembly.
- Step 8.** Remove the two TORX T6 screws (item 4) fastening the Inverter and the insulator.
- Step 9.** Remove the Inverter (item 5) with the insulator (item 6) from the Front Panel Assembly. Then, remove the Inverter from the insulator.

### Replacement Procedure

- Step 1.** Reverse the order of the removal procedure.

#### NOTE

When you fasten the Inverter and the insulator with the two TORX T6 screws, set screwdriver's torque to 3.05 in-lb.

---

Replacement Procedure  
Inverter Replacement

Figure 6-17 Inverter Removal

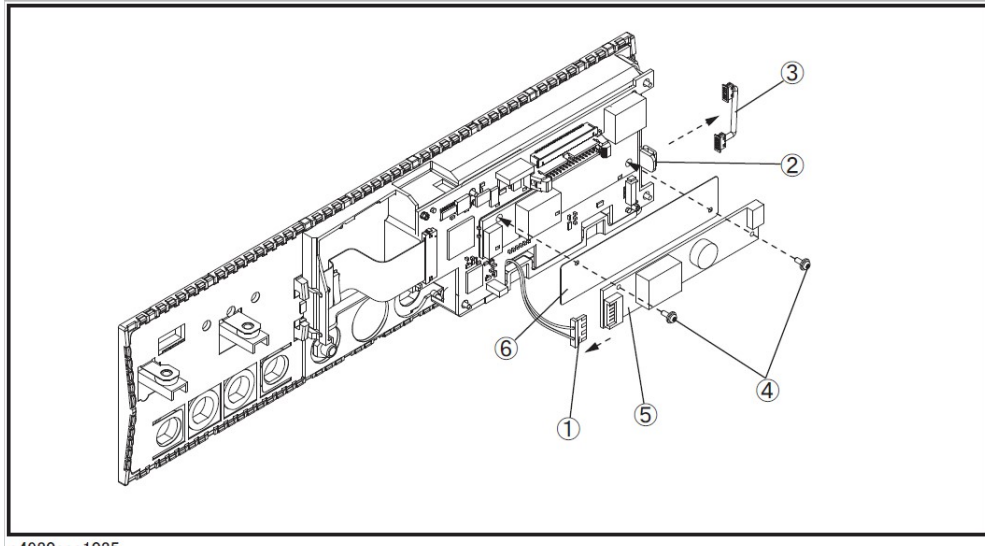

## Front Panel, Key Pad, and Key Flex Circuit Replacement

### Tools Required

- Torque screwdriver, TORX T10
- Torque screwdriver, TORX T20
- Box torque wrench, 7 mm
- Box torque wrench, 5/8 inch

### Removal Procedure

Refer to **Figure 6-18** for this procedure.

- Step 1.** Remove the 3/4 Rack Module Top as described in **“3/4 Rack Module Top Replacement” on page 73.**
- Step 2.** Remove the PCA E4980 USB as described in **“PCA E4980 USB Replacement” on page 102.**
- Step 3.** Remove the A3 Analog Daughter Board as described in **“A3 Analog Daughter Board Replacement” on page 77.**
- Step 4.** Remove the A2 Analog Board as described in **“A2 Analog Board Replacement” on page 79.**
- Step 5.** Remove the Front Panel Assembly as described in **“Front Panel Assembly Removal” on page 81.**
- Step 6.** Disconnect the Display Cable (item 1) from the Key Flex Circuit.
- Step 7.** Carefully remove the Display Support with the LCD display (item 2) from the Front Panel.

#### NOTE

When removing the Display Support, release the hook (flat cable side) of the Display Support first, and then carefully release the other hooks of the Display Support.

Be careful not to break the hooks.

---

- Step 8.** Remove the Front Panel (item 3) from the Key Pad (item 4), the Window EMI Shield (item 5), the Key Flex Circuit (item 6), and the EMI Shield (item 7).

### Replacement Procedure

- Step 1.** Reverse the order of the removal procedure.

Replacement Procedure  
Front Panel, Key Pad, and Key Flex Circuit Replacement

Figure 6-18 Front Panel, Key Pad, and Key Flex Circuit Removal

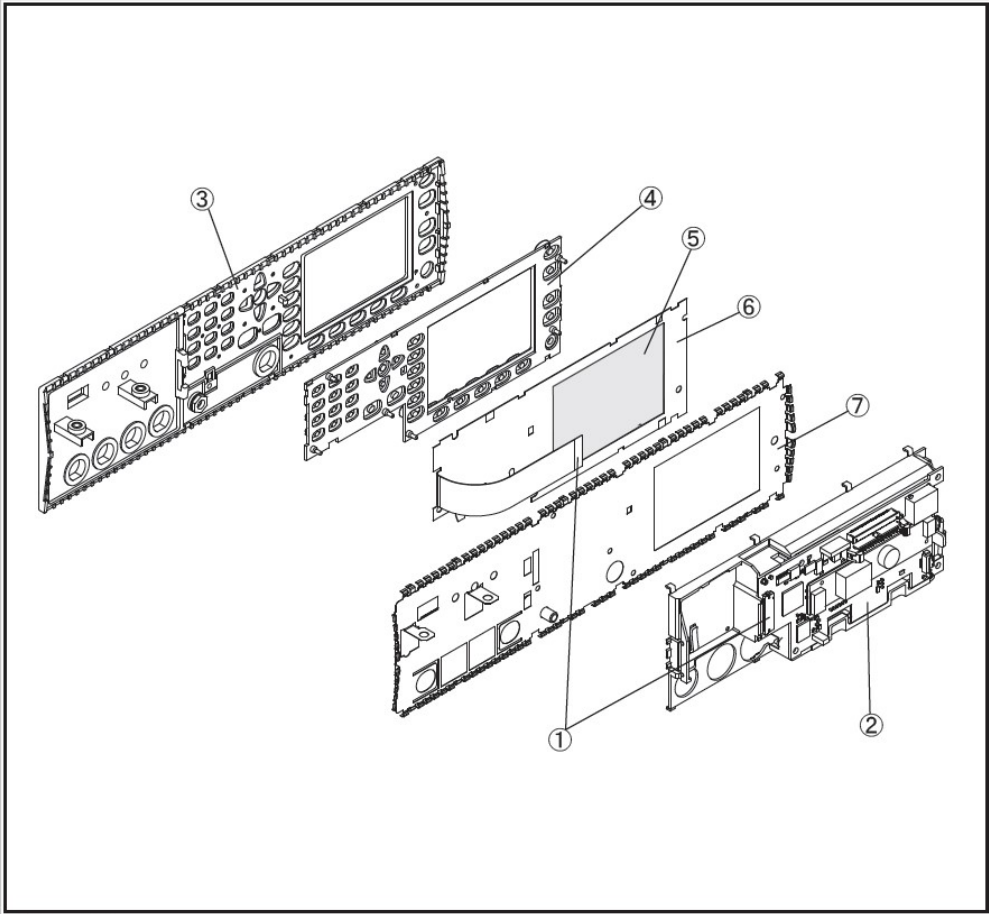

## Display Interface Replacement

### Tools Required

- Torque screwdriver, TORX T10
- Torque screwdriver, TORX T20
- Torque screwdriver, TORX T6
- Box torque wrench, 7 mm
- Box torque wrench, 5/8 inch

### Removal Procedure

Refer to **Figure 6-19** for this procedure.

- Step 1.** Remove the 3/4 Rack Module Top as described in **“3/4 Rack Module Top Replacement” on page 73.**
- Step 2.** Remove the PCA E4980 USB as described in **“PCA E4980 USB Replacement” on page 102.**
- Step 3.** Remove the A3 Analog Daughter Board as described in **“A3 Analog Daughter Board Replacement” on page 77.**
- Step 4.** Remove the A2 Analog Board as described in **“A2 Analog Board Replacement” on page 79.**
- Step 5.** Remove the Front Panel Assembly as described in **“Front Panel Assembly Removal” on page 81.**
- Step 6.** Remove the Inverter as described in **“Inverter Replacement” on page 105.**
- Step 7.** Remove the Front Panel, the Key Pad, and the Key Flex Circuit as described in **“Front Panel, Key Pad, and Key Flex Circuit Replacement” on page 107.**
- Step 8.** Remove the four TORX T6 screws (item 1) fastening the LCD Display.
- Step 9.** Remove the LCD Display (item 2) from the Display Support with the Display Interface.
- Step 10.** Carefully remove the Display Interface (item 3) from the Display Support (item 4).

### Replacement Procedure

- Step 1.** Reverse the order of the removal procedure.

#### NOTE

When you fasten the LCD Display with the four TORX T6 screws, set screwdriver's torque to 3.05 in-lb.

When you replace the LCD Display with a new one, stick new gaskets (P/N : E4980-25003 x 2, E4980-25004 x 2) to surroundings on the LCD Display.

---

Replacement Procedure  
Display Interface Replacement

Figure 6-19 Display Interface Removal

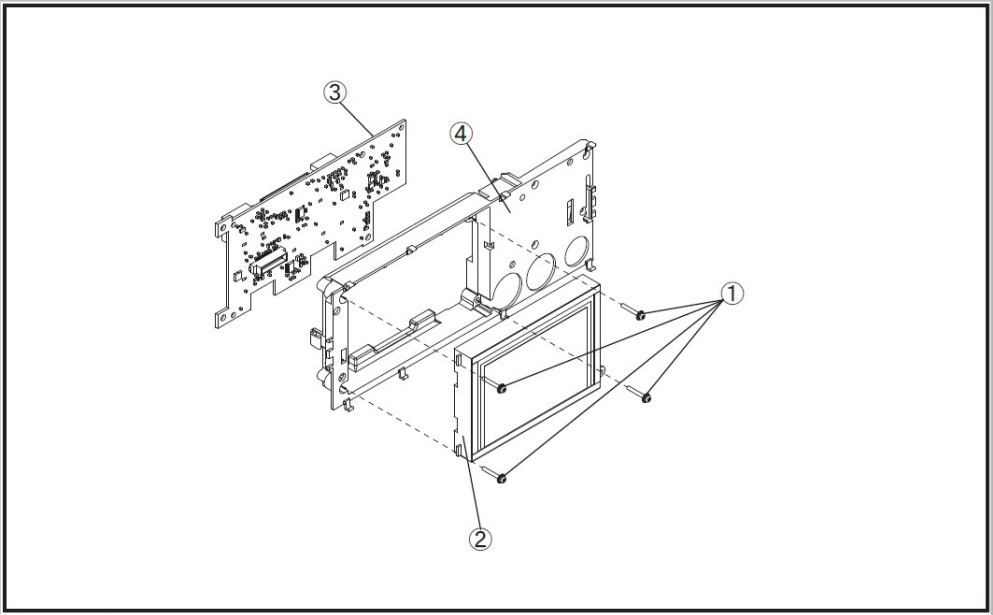

## 7 Post-Repair Procedures

This chapter lists the procedures required to verify the E4980A/ E4980AL operation after an assembly is replaced with a new one.

### Post-Repair Procedures

**Table 7-1** Post Repair Procedures lists the required procedures that must be performed after the replacement of an assembly. These are the recommended minimum procedures to ensure that the replacement is successfully completed.

**Table 7-1 Post-Repair Procedures**

Replaced Assembly or Part	Required Adjustments Correction Constants (CC)	Verification
PPMC Processor and IO Module (E4980-62004)	At first, it is required to install the latest firmware based on "Appendix B Firmware Update".  Perform the following required adjustments using "PPMC" in Spot Adjustment of the program.  Power On Test Limit	Inspect the booting process, and power on test result.
A1 Mother Board	Perform the following required adjustments using "A1 Board" in Spot Adjustment of the program.  Write ID	Inspect the booting process, and power on test result.

Table 7-1 Post-Repair Procedures

Replaced Assembly or Part	Required Adjustments Correction Constants (CC)	Verification
A2 Analog Board	Perform the following required adjustments using “A2 Board” in Spot Adjustment of the program. Write Null phase track default data Null DC offset Adjustment Null ADC DC offset Adjustment ADC Linearity Adjustment DC Bias Adjustment DC level V monitor Adjustment (for opt 001) DC level I monitor Adjustment (for opt 001) DC Source Adjustment (for opt 001) DCR Adjustment (for opt 001) Impedance Adjustment AC Level monitor Adjustment OSC Level Adjustment	Inspect the booting process, and power on test result.  DC Bias V Level Monitor Accuracy Test (for opt 001) DC Bias I Level Monitor Accuracy Test (for opt 001) AC Signal Level Monitor Accuracy Test Impedance Measurement Accuracy Test DCR Measurement Accuracy Test (for opt 001)
A3 Analog Board	Perform the following required adjustments using “A3 Board” in Spot Adjustment of the program. DC Bias Adjustment DC level V monitor Adjustment (for opt 001) DC level I monitor Adjustment (for opt 001) DC Source Adjustment (for opt 001) DCR Adjustment (for opt 001) Impedance Adjustment AC Level monitor Adjustment OSC Level Adjustment	Inspect the booting process, and power on test result.  Frequency Accuracy Test DC Source Level Monitor Accuracy Test (for opt 001) DC Bias Level Accuracy Test (for opt 001) AC Signal Level Accuracy Test Impedance Measurement Accuracy Test DCR Measurement Accuracy Test (for opt 001)
USB Board	No adjustment needed	Inspect the booting process, and power on test result.  <b>“To Check the Front USB port” on page 49</b>



Table 7-1 Post-Repair Procedures

Replaced Assembly or Part	Required Adjustments Correction Constants (CC)	Verification
Power Supply	No adjustment needed	Inspect the booting process, and power on test result.
Fan Assembly	No adjustment needed	Inspect the booting process, and power on test result.
LCD Assembly	No adjustment needed	Inspect the booting process, and power on test result. <b>“To Check the LCD” on page 48</b> DC Bias Level Accuracy Test (for opt 001)
Key Assembly	No adjustment needed	Inspect the booting process, and power on test result. <b>“To Check the Front Panel” on page 48</b> DC Bias Level Accuracy Test (for opt 001)
Handler I/F (option 201)	No adjustment needed	Inspect the booting process, and power on test result. <b>“To Check the Handler Interface Function (Option 201 only)” on page 52</b>
Scanner I/F (option 301)	No adjustment needed	Inspect the booting process, and power on test result. <b>“To Check the Scanner Interface Function (Option 301 only)” on page 57</b>
Bias Current I/F (option 002)	No adjustment needed	Inspect the booting process, and power on test result. <b>“To Check the Bias Current Interface Function (Option 002 only)” on page 60</b>

Post-Repair Procedures  
Post-Repair Procedures

## A Manual Changes

This appendix contains the information required to adapt this manual to versions or configurations of the E4980A/E4980AL manufactured earlier than the current printing date of this manual. The information in this manual applies directly to E4980A/E4980AL units with the serial number that is printed on the title page of this manual.

### Manual Changes

To adapt this manual to your E4980A/E4980AL, refer to [Table A-1](#) and [Table A-2](#).

**Table A-1 Manual Changes by Serial Number**

Serial Prefix or Number	Make Manual Changes

**Table A-2 Manual Changes by Firmware Version**

Version	Make Manual Changes

The ten-character serial number is printed on the serial number label ([Figure A-1](#)) on the rear panel.

Figure A-1 Serial Number Plate Example



Manual Changes  
Manual Changes

## B Firmware Update

This appendix describes how to update the E4980A/ E4980AL firmware. When you want to update the E4980A/ E4980AL firmware, refer to this appendix.

### Update the E4980A/ E4980AL firmware using USB/GPIB interface

Refer to [Keysight E4980A/AL Product Page](#) for detailed instruction.

#### Required Equipment

- E4980A/ E4980AL.
- 82357A USB/GPIB interface.
- Personal Computer with I/O Libraries Suite (Windows 2000/XP/ 7).

#### How to update E4980A/ E4980AL firmware using USB/GPIB interface

The following is the procedure to update the E4980A/ E4980AL firmware using USB/GPIB interface.

- Step 1.** Connect the USB/GPIB interface from the USB terminal in your computer to the GPIB terminal in the E4980A/ E4980AL rear panel. Then turn the E4980A/ E4980AL on.
- Step 2.** Copy the following file from Keysight Technologies web site to the temporary work folder in your computer's HDD.
  - fw\_upd.exe
- Step 3.** Execute the **Command Prompt** on your computer.
- Step 4.** Change the current folder to the temporary working folder with the "fw\_upd.exe" file using **cd** command.
- Step 5.** Enter **fw\_upd.exe GPIB0::17::INSTR** command to execute the firmware update program. The numerical value of "17" in the command is GPIB address of the E4980A/ E4980AL. Then, press the Enter key.
- Step 6.** Wait a few minutes until the command prompt is displayed again.

## Firmware Update

Update the E4980A/ E4980AL firmware using USB/GPIB interface

- Step 7.** Press **System** key on the E4980A/ E4980AL front panel to check the firmware revision.

## Update the E4980A/ E4980AL firmware using USB cable

### Required Equipment

- E4980A/ E4980AL.
- USB cable connecting the E4980A/ E4980AL and external controller (with type A/4-prong male or type mini-B/5-prong male connectors depending on device used).
- Personal Computer with I/O Libraries Suite (Windows 2000/XP/ 7).

### How to update E4980A/ E4980AL firmware using USB cable

The following is the procedure to update the E4980A/ E4980AL firmware using USB cable.

- Step 1.** Connect the USB cable from the USB terminal in your computer to the USB terminal in the E4980A/ E4980AL rear panel. Then turn the E4980A/ E4980AL on.
- Step 2.** Copy the following file from Keysight Technologies web site to the temporary work folder in your computer's HDD.
  - fw\_upd.exe
- Step 3.** Execute the **Command Prompt** on your computer.
- Step 4.** Change the current folder to the temporary working folder with the "fw\_upd.exe" file using **cd** command.
- Step 5.** Enter **fw\_upd.exe USB0::2391::2313::MY12345678::0::INSTR** command to execute the firmware update program. The entered value of "2391::2313::MY12345678" in the command is USB ID of the E4980A/ E4980AL, and the entered value of "MY12345678" is serial number of the E4980A/ E4980AL. Then, press the Enter key.
- Step 6.** Wait a few minutes until the command prompt is displayed again.
- Step 7.** Press **System** key on the E4980A/ E4980AL front panel to check the firmware revision.

Firmware Update  
Update the E4980A/ E4980AL firmware using USB cable



## C Power Requirement

### Replacing Fuse

#### Fuse Selection

Select proper fuse according to the [Table C-1](#).

**Table C-1 Fuse Selection**

Fuse Rating/Type	Fuse Part Number
3A 250Vac UL/CSA type Time Delay	2110-1017

#### Setting up the fuse

Use the fuse that meets the following specifications.

**UL/CSA type, Slo-Blo, 5x20mm miniature fuse, 3A 250V (part number: 2110-1017)**

Spare fuses are available from Keysight Technologies sales office. To check or replace the fuse, disconnect the power cable and pull out the fuse holder (refer to [Figure C-1](#)) towards you (refer to [Figure C-2](#)).

**Figure C-1 Fuse holder and power cable socket**

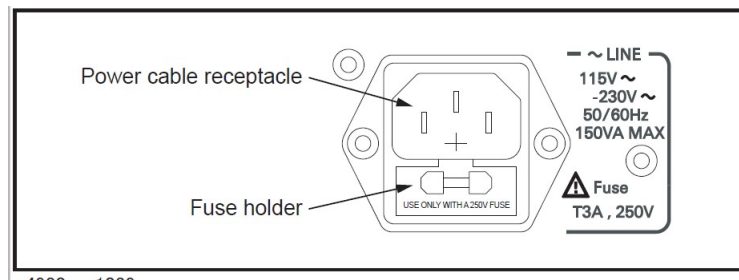
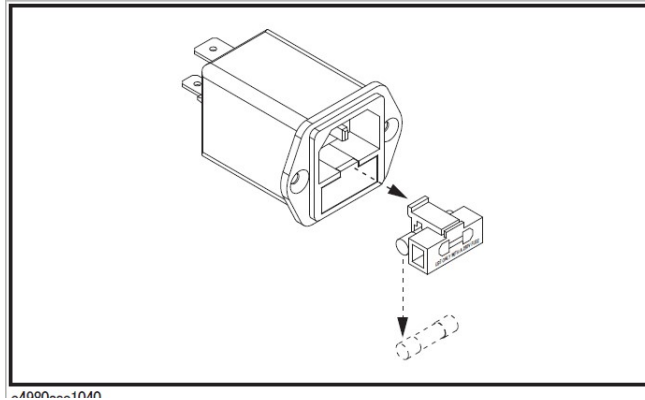

Figure C-2

### Removing the fuse



## Power Requirements

The E4980A/ E4980AL requires the following power source.

Voltage : 90 to 132 Vac, 198 to 264 Vac  
Frequency : 47 to 63 Hz  
Power : 150 VA maximum

### Power Cable

In accordance with international safety standards, this instrument is equipped with a three-wire power cable. When connected to an appropriate ac power outlet, this cable grounds the instrument frame.

The type of power cable shipped with each instrument depends on the country of destination.

For power cord list, refer to <https://www.keysight.com/find/powercords> which shows the power cable options.

### **WARNING**

For protection from electrical shock, the power cable ground must not be defeated.

The power plug must be plugged into an outlet that provides a protective earth ground connection.

---

## D Error Messages

The Keysight E4980A/ E4980AL provides error messages to indicate its operating status. This appendix describes the error messages of the E4980A/ E4980AL in alphabetical order.

### Error Messages

An error message is displayed in the instrument status display area in the lower-left part of the screen. Pressing the cursor arrow key on the front panel or executing the :DISP:CCL command clears the error message. Moreover, about a specific error message, when a sweep is started again, the display of an error message may disappear. Errors caused by operation of a front panel key simply appear on the display; with a few exceptions, these are not stored in the error queue.

The log of an error message, a maximum of 100 pieces are recorded, and it can go back and check from the oldest error. Executing the :SYST:ERR? command checks error logs. This operation can be performed only by "SCPI" command. It cannot be operated from the front panel.

An error with a positive error number is one uniquely defined for this instrument. On the other hand, an error with a negative error number is basically one defined for common GPIB devices in IEEE488.2.

	A	
1103		<b>A1 EEPROM write error</b>
		An error is generated while writing data to A1 EEPROM. When this error occurs, contact Keysight Technology's Sales and Service Office or the company from which you bought the device.
	B	
62		<b>Bias off, Turn bias on</b>
		DC bias sweep is performed with the DC BIAS function OFF.
-160		<b>Block data error</b>
		Block data is improper.

-168           **Block data not allowed**  
Block data is not allowed.

C

-140           **Character data error**  
Character data is improper.

-148           **Character data not allowed**  
Character data not allowed for this operation.

-144           **Character data too long**  
Character data is too long (maximum length is 12 characters).

-100           **Command Error**  
Improper command.

41             **Correction measurement aborted**  
Correction data measurement is aborted.

1201           **CPU Bd EEPROM write error**  
An error is generated while writing data to EEPROM. When this error occurs, contact Keysight Technology's Sales and Service Office or the company from which you bought the device.

1200           **CPU Bd FLASH ROM write error**  
An error is generated while writing data to FLASH. When this error occurs, contact Keysight Technology's Sales and Service Office or the company from which you bought the device.

29             **Cycle power of 42841A and Preset**  
The connection was not established with the 42841A. Cycle the power of the 42841A, then preset the E4980A/ E4980AL.

D

90             **Data buffer overflow**  
This error occurs when the amount of data exceeds the defined data buffer memory size. If this error occurs during the measurement after pressing [Save/Recall] - SAVE DATA - START LOG, press SAVE & STOP.

-230           **Data corrupt or stale**  
The setting file or correction data to be read cannot be read out with the current firmware version because the setting file or correction data is corrupt or old.

-222           **Data out of range**

A data element (not violating the standard) outside the range defined by this instrument has been received. This error occurs, for example, when an integer-based command for which the parameter can be rounded exceeds the range of -2147483648 to +2147483647 or when a real-number-based command for which the parameter can be rounded exceeds the range of -9.9e37 to +9.9e37. This error also occurs when a numeric value other than a specified one is entered into a command in which the “BIN number” and “list table number” are specified as parameters and thus the parameters are not rounded.

-104

**Data type error**

Improper data type used (for example, string data was expected, but numeric data was received).

26

**DC bias I sink overload**

DC bias sink current is overloaded. When this error occurs, lower the value of the current setting.

25

**DC bias I source overload**

DC bias source current is overloaded. When this error occurs, lower the value of the current setting

19

**DC bias not available**

DC bias cannot be turned on in Rdc measurement.

18

**DC bias opt not installed**

Operation that requires option 001 is performed in a model not having the power amp/DC bias option (option 001).

28

**DC bias unit connection changed**

The connection with the 42841A has been changed. Cycle the power of the 42841A, then preset the E4980A/ E4980AL.

27

**DC bias unit disconnected**

The 42841A is not connected. Confirm the connection to the 42841A.

20

**DC bias unit powered down**

The 42841A is switched off. Turn on the switch.

63

**DC source off, Turn DC source on**

DC source sweep is performed with the DC source function OFF. Set the DC source function to ON.

E

10

**Exceeded AC+DC limit**

The amount of the voltage level exceeds 42V peak. Lower the DC voltage or AC voltage setting.

- 200           **Execution error**  
An error associated with execution has been generated for which this instrument cannot specify the error message. This code indicates that an error associated with execution defined in 11.5.1.1.5, IEEE488.2 has occurred.
- 123           **Exponent too long**  
The magnitude of the exponent was larger than 32000.
- 178           **Expression data not allowed**  
Expression data is not allowed.
- 170           **Expression error**  
Expression is improper.

F

- 1070           **Fan failed**  
Cooling fan hardware failure is detected. When this error occurs, contact Keysight Technology's Sales and Service Office or the company from which you bought the device.
- 21             **Fixture circuit defective**  
A fault has occurred in a circuit to absorb back-emf of the 42842A/B. Confirm the connection to the 42842A/B.
- 24             **Fixture cover open**  
The protective cover of the 42842A/B is open. Close the cover.
- 23             **Fixture OPEN det. defective**  
The opening and closing detection sensor of the 42842A/B protective cover detects an error. When this error occurs, contact Keysight Technology's Sales and Service Office or the company from which you bought the device.
- 22             **Fixture over temperature**  
The temperature inside the 42842A/B bias test fixture exceeds the limit. Turn off the DC bias and cool down the equipment.
- 30             **Function type not available**  
The Ls-Rdc, Lp-Rdc and Vdc-Idc are not available when the 42841A is connected.

G

- 105           **GET not allowed**  
GET is not allowed inside a program message.

## H

70                   **Handler I/F not installed**  
The handler interface function is set to ON in a model that does not have a handler interface board (option 201).

-114               **Header Suffix out of Range**  
The header suffix is out of range.

## I

73                   **I BIAS I/F not installed**  
The DC bias interface function is set to ON in a model that does not have the DC bias interface board (option 002).

-224               **Illegal parameter value**  
The parameter value is not properly set. This error occurs, for example, when the :FUNC:IMP command is used to specify an Impedance-parameter that does not exist (as CPRS).

51                   **Inconsistent limit setting**  
For the comparator function, user attempts to set the threshold in the sequential mode by sending the COMP:SEQ:BIN command, although the tolerance mode is now selected. Select the sequential mode using COMP:MODE.

-161               **Invalid block data**  
Invalid block data was received (for example, END received before length satisfied).

-101               **Invalid character**  
Invalid character was received.

-141               **Invalid character data**  
Bad character data or unrecognized character data was received.

-121               **Invalid character in number**  
Invalid character in numeric data.

-171               **Invalid expression**  
Invalid expression was received (for example, illegal character in expression).

-103               **Invalid separator**  
The message unit separator (for example, “;”, “;”) is improper.

-151               **Invalid string data**

Invalid string data was received (for example, END received before close quote).

-131

**Invalid suffix**

Units are unrecognized, or the units are not appropriate.

M

-250

**Mass storage error**

An error occurred while accessing the USB memory. A USB memory-related error other than -257 error (File Name Error) occurred.

43

**Measurement failed**

A measurement error occurred during correction data measurement. The OPEN or SHORT state connected to the UNKNOWN terminals may be inappropriate.

-109

**Missing parameter**

The number of parameters is less than that required for the command, or the parameter has not been entered. For example, the command “:CORR:USE” requires one more parameter. Therefore, when a message “:CORR:USE” is sent to a correct program message “:CORR:USE 11,” this instrument receives the former message as an invalid one because all parameters have not been entered. Enter command parameters correctly.

N

83

**No data to load**

There is no setup data for the selected number. Or the USB memory is not inserted.

60

**No values in sweep list**

List sweep measurement is performed when the measurement point is not set on the LIST SWEEP SETUP screen.

-128

**Numeric data error**

Numeric data is improper.

-128

**Numeric data not allowed**

Numeric data not allowed for this operation.

O

83

**Out of Memory**

The E4980A/ E4980AL has insufficient memory to perform the requested operation.



P

- 220      **Parameter error**
- When a parameter-related error other than Errors -221 through -229 occur, this error message is displayed.
- 108      **Parameter not allowed**
- The number of parameters exceeds that required for the command. For instance, when a program message “:FORM:BORD NORM, ASC” is sent instead of a correct program message with a command “:FORM:BORD NORM”, which requires a parameter, the instrument receives the message that the number of parameters is invalid. See the command reference to confirm the required number of parameters.
- 1080      **Power failed**
- Power unit hardware failure is detected. Contact Keysight Technology’s Sales and Service Office or the company from which you bought the device.
- 1000      **Power on test failed**
- An error occurs during a self test at power-on. The E4980A/ E4980AL may be faulty. Contact Keysight Technology’s Sales and Service Office or the company from which you bought the device.
- A self test fails when an interface board is removed or not connected properly. Check the connection with a cable when you change the setting of the interface board.
- 112      **Program mnemonic too long**
- Program mnemonic is too long (maximum length is 12 characters).

Q

- 350      **Queue overflow**
- There is no room in the queue and an error occurred but was not recorded. Clear the error queue.
- 430      **Query DEADLOCKED**
- Input buffer and output buffer are full; cannot continue.
- 400      **Query error**
- Query is improper.
- 410      **Query INTERRUPTED**
- Query is followed by DAB or GET before the response is completed.
- 420      **Query UNTERMINATED**
- Addressed to talk, incomplete program message received.

-440		<b>Query UNTERMINATED error after indefinite response</b> A query that requests arbitrary data response ( <b>*IDN?</b> and <b>*OPT?</b> queries) is sent before normal queries in a program message (for example, <b>FREQ?;*IDN?</b> is expected, but <b>*IDN?;FREQ?</b> is received).
	R	
16		<b>Reference Measurement aborted</b> Reference data measurement is aborted.
	S	
71		<b>Scanner I/F not installed</b> Operation that requires option 301 is performed in a model that does not have a scanner interface board (option 301).
82		<b>Store failed</b> User attempts to save data into number 10 to 19 when a USB memory device is not inserted. Prepare the USB memory device or save data into number 0 to 9.
-150		<b>String data error</b> String data is improper.
-158		<b>String data not allowed</b> String data is not allowed.
-138		<b>Suffix not allowed</b> A suffix is not allowed for this operation.
-102		<b>Syntax error</b> Unrecognized command or data type was received.
	T	
-223		<b>Too many digits</b> The received numeric value is too long (exceeds 255 digits).
-223		<b>Too much data</b> The block-, expression-, or character-string-type program data that are received conform with the standard but exceed the amount that can be processed under the condition of the memory or conditions specific to memory-related devices. In this instrument, this error occurs when the number of characters exceeds 254 in a character-string parameter.
-211		<b>Trigger ignored</b>

The instrument receives and detects a trigger command (“:TRIG”) or an external trigger signal, but it is ignored due to the timing condition (the instrument is not in the wait-for- trigger state, for example). Change the setup so that a trigger command or an external trigger signal can be sent after the instrument has entered the wait-for- trigger state.

## U

-113

### **Undefined header**

A command not defined in this instrument, though not illegal in the syntactic structure, has been received. For example, when the message “:OUTP:DC:ISOL:FREQ:AUTO ON” is sent instead of the correct program message “:OUTP:DC:ISOL:LEV:AUTO ON” the message sent is received as an undefined command by this instrument. See the command reference and use the correct command.

## V

14

### **V bias disabled**

The DC voltage bias is set when the 42841A is connected. Set the DC current bias or disconnect the 42841A.

45

### **Valid in single mode only**

SINGLE channel correction data is measured when the MULTI channel correction mode is set.

## Warning Message

A warning message is displayed in the instrument status display area in the lower-left part of the display. Pressing any of the front panel keys or executing the :DISP:CCL command clears the message.

This message simply appears on the display since it is not known to remote environments such as GPIB. This message is not displayed when another error message has been already displayed in the instrument message/warning area.

The warning messages for this instrument are as follows.

### Numeric

#### **1 I bias unit**

The E4980A/ E4980AL finds one current bias unit (42841A) connected.

#### **2 I bias units**

The E4980A/ E4980AL finds two current bias units (42841A) connected.

### A

#### **ALC unable to regulate**

The voltage level setting is inappropriate for using the ALC function. The ALC function does not work and the operation will be the same as when the ALC function is turned off. The measurement data status is set to 4. Refer to E4980A/ E4980AL User's Guide.

### C

#### **Clear the table first**

This error occurs when the value of MODE has been changed when the LIMIT TABLE SETUP screen is moved to another screen or the sweep parameter on the LIST SWEEP SETUP screen is changed even though a sweep list for another measurement parameter exists. Clear the table first.

#### **Correction, not effective**

The correction function does not work because the MULTI correction mode is used but the test frequency is not equal to the spot frequency.

### I

#### **Improper high/low limits**

The upper limit value is less than the lower limit value. Set the lower limit value to less than the upper limit value.

#### **Incompatible state file**

Error Messages  
Warning Message

The setting file recalled from a USB memory device has been saved using an E4980A/ E4980AL with a different firmware version or different options. There may be some parameters set up incorrectly. Check the setting.

S

### **Signal source overload**

The signal source is overloaded. The measurement data is not guaranteed to be valid. The measurement result data status of the measurement result output is set to 3.

When measuring Ls-Rdc/Lp-Rdc, set both RANGE and DCR RNG properly, or "OVERLOAD" will be displayed.

### **Signal source overvoltage**

The signal source voltage exceeds its limit. Lower the voltage setting of the signal source.

Error Messages  
Warning Message

This information is subject to change without notice.  
© Keysight Technologies 2006-2023  
Edition 9, March 2023



E4980-90120  
[www.keysight.com](http://www.keysight.com)