

# Keysight M8192A

Synchronization module for M8190A  
and M8121A

User's Guide

# Notices

© Keysight Technologies, Inc. 2022

No part of this manual may be reproduced in any form or by any means (including electronic storage and retrieval or translation into a foreign language) without prior agreement and written consent from Keysight Technologies, Inc. as governed by United States and international copyright laws.

## Manual Part Number

M8192-91020

## Edition

Edition 9.0, February 2022

Keysight Technologies,  
Deutschland GmbH  
Herrenberger Str. 130  
71034 Böblingen, Germany

## For Assistance and Support

<http://www.keysight.com/find/assist>

## Limitation of Warranty

The foregoing warranty shall not apply to defects resulting from improper or inadequate maintenance by Buyer, Buyer-supplied software or interfacing, unauthorized modification or misuse, operation outside of the environmental specifications for the product, or improper site preparation or maintenance. No other warranty is expressed or implied. Keysight Technologies specifically disclaims the implied warranties of Merchantability and Fitness for a Particular Purpose.

## ESD sensitive device

All front-panel connectors of the M8192A and the M8190A/M8121A are sensitive to Electrostatic discharge (ESD). We recommend to operate the instrument in an electrostatic safe environment.

There is a risk of instrument malfunction when touching a connector.

Please follow this instruction:

Before touching the front-panel connectors, discharge yourself by touching the properly grounded mainframe.

## Warranty

**THE MATERIAL CONTAINED IN THIS DOCUMENT IS PROVIDED "AS IS," AND IS SUBJECT TO BEING CHANGED, WITHOUT NOTICE, IN FUTURE EDITIONS. FURTHER, TO THE MAXIMUM EXTENT PERMITTED BY APPLICABLE LAW, KEYSIGHT DISCLAIMS ALL WARRANTIES, EITHER EXPRESS OR IMPLIED, WITH REGARD TO THIS MANUAL AND ANY INFORMATION CONTAINED HEREIN, INCLUDING BUT NOT LIMITED TO THE IMPLIED WARRANTIES OF MERCHANTABILITY AND FITNESS FOR A PARTICULAR PURPOSE. KEYSIGHT SHALL NOT BE LIABLE FOR ERRORS OR FOR INCIDENTAL OR CONSEQUENTIAL DAMAGES IN CONNECTION WITH THE FURNISHING, USE, OR PERFORMANCE OF THIS DOCUMENT OR OF ANY INFORMATION CONTAINED HEREIN. SHOULD KEYSIGHT AND THE USER HAVE A SEPARATE WRITTEN AGREEMENT WITH WARRANTY TERMS COVERING THE MATERIAL IN THIS DOCUMENT THAT CONFLICT WITH THESE TERMS, THE WARRANTY TERMS IN THE SEPARATE AGREEMENT SHALL CONTROL.**

## Technology Licenses

The hardware and/or software described in this document are furnished under a license and may be used or copied only in accordance with the terms of such license.

## Restricted Rights Legend

If software is for use in the performance of a U.S. Government prime contract or subcontract, Software is delivered and licensed as

"Commercial computer software" as defined in DFAR 252.227-7014 (June 1995), or as a "commercial item" as defined in FAR 2.101(a) or as "Restricted computer software" as defined in FAR 52.227-19 (June 1987) or any equivalent agency regulation or contract clause. Use, duplication or disclosure of Software is subject to Keysight Technologies' standard commercial license terms, and non-DOD Departments and Agencies of the U.S. Government will receive no greater than Restricted Rights as defined in FAR 52.227-19(c)(1-2) (June 1987). U.S. Government users will receive no greater than Limited Rights as defined in FAR 52.227-14 (June 1987) or DFAR 252.227-7015 (b)(2) (November 1995), as applicable in any technical data.

## Safety Notices

### CAUTION

A **CAUTION** notice denotes a hazard. It calls attention to an operating procedure, practice, or the like that, if not correctly performed or adhered to, could result in damage to the product or loss of important data. Do not proceed beyond a **CAUTION** notice until the indicated conditions are fully understood and met.

### WARNING





A **WARNING** notice denotes a hazard. It calls attention to an operating procedure, practice, or the like that, if not correctly performed or adhered to, could result in personal injury or death. Do not proceed beyond a **WARNING** notice until the indicated conditions are fully understood and met.

## Safety Summary



General Safety Precautions	<p>The following general safety precautions must be observed during all phases of operation of this instrument. Failure to comply with these precautions or with specific warnings elsewhere in this manual violates safety standards of design, manufacture, and intended use of the instrument. For safe operation the general safety precautions for the M9502A and M9505A AXIe chassis, must be followed. See: <a href="http://www.keysight.com/find/M9505A">http://www.keysight.com/find/M9505A</a> Keysight Technologies Inc. assumes no liability for the customer's failure to comply with these requirements. Before operation, review the instrument and manual for safety markings and instructions. You must follow these to ensure safe operation and to maintain the instrument in safe condition.</p>
Initial Inspection	<p>Inspect the shipping container for damage. If there is damage to the container or cushioning, keep them until you have checked the contents of the shipment for completeness and verified the instrument both mechanically and electrically. The Performance Tests give procedures for checking the operation of the instrument. If the contents are incomplete, mechanical damage or defect is apparent, or if an instrument does not pass the operator's checks, notify the nearest Keysight Technologies Sales/Service Office.</p> <p><b>WARNING</b> To avoid hazardous electrical shock, do not perform electrical tests when there are signs of shipping damage to any portion of the outer enclosure (covers, panels, etc.).</p>
General	<p>This product is a Safety Class 3 instrument. The protective features of this product may be impaired if it is used in a manner not specified in the operation instructions.</p>
Environment Conditions	<p>This instrument is intended for indoor use in an installation category II, pollution degree 2 environment. It is designed to operate within a temperature range of 0 °C – 40 °C (32 °F – 105 °F) at a maximum relative humidity of 80% and at altitudes of up to 2000 meters.</p> <p>This module can be stored or shipped at temperatures between -40 °C and +70 °C. Protect the module from temperature extremes that may cause condensation within it.</p>
Before Applying Power	<p>Verify that all safety precautions are taken including those defined for the mainframe.</p>
Line Power Requirements	<p>The Keysight M8192A and the M8190A/M8121A operates when installed in an Keysight AXIe mainframe.</p>
Do Not Operate in an Explosive Atmosphere	<p>Do not operate the instrument in the presence of flammable gases or fumes.</p>
Do Not Remove the Instrument Cover	<p>Operating personnel must not remove instrument covers. Component replacement and internal adjustments must be made only by qualified personnel. Instruments that appear damaged or defective should be made inoperative and secured against unintended operation until they can be repaired by qualified service personnel.</p>

## Safety Symbols

**Table 1 Safety Symbol**

Symbol	Description
	Indicates warning or caution. If you see this symbol on a product, you must refer to the manuals for specific Warning or Caution information to avoid personal injury or damage to the product.
	C-Tick Conformity Mark of the Australian ACA for EMC compliance.
	CE Marking to state compliance within the European Community: This product is in conformity with the relevant European Directives.
	General Recycling Mark

**Table 2 Compliance and Environmental Information**

Symbol	Description
	This product complies with the WEEE Directive (2002/96/EC) marketing requirements. The affixed label indicates that you must not discard this electrical/electronic product in domestic household waste. Product category: With reference to the equipment types in the WEEE Directive Annexure I, this product is classed as a "Monitoring and Control instrumentation" product.
	Do not dispose in domestic household waste.
	To return unwanted products, contact your local Keysight office, or see <a href="http://about.keysight.com/en/companyinfo/environment/takeback.shtml">http://about.keysight.com/en/companyinfo/environment/takeback.shtml</a> for more information.

## Contents

<b>1</b>	<b>Introduction</b>	
1.1	Document History	11
1.2	Accessories	12
1.3	M8192A Front Panel	12
<b>2</b>	<b>M8192A Installation</b>	
2.1	Introduction	16
2.1.1	Pre-Requisites	16
2.1.2	Installation Process	17
2.1.3	Post Installation Steps	23
2.1.4	How to Control the Instrument	24
2.2	AXI Chasis	24
2.2.1	ESM Front Panel Connector	24
<b>3</b>	<b>System Configuration</b>	
3.1	Introduction	28
3.1.1	4 M8190A/M8121A Arbitrary Waveform Generator Channels	28
3.1.2	6 (or 8) M8190A/M8121A Arbitrary Waveform Generator Channels	29
3.1.3	10 (or 12) M8190A/M8121A Arbitrary Waveform Generator Channels	29
3.2	Supported AXIe Frame Combinations	29
3.3	Controlling One AXIe Chassis	31
3.4	Controlling Multiple AXIe Chassis	33
3.4.1	One PC Controls Multiple Chassis	33
3.4.2	Multiple PC Controls Multiple Chassis	35
3.5	Synchronous System Cabling	36
3.6	Controlling the Synchronous System	37
3.6.1	Requirements for Controlling the Synchronous System	37
3.6.2	Synchronous System Operation Modes	37
3.6.3	Control Parameters	39
<b>4</b>	<b>M8192A Soft Front Panel</b>	
4.1	Introduction	42
4.2	Launching the M8192A Soft Front Panel	42
4.3	M8192A Soft Front Panel	44
4.3.1	Title Bar	45
4.3.2	Menu Bar	45

4.3.3	Status Bar	47
4.3.4	Tabs (Module/Sync Tabs)	47
4.3.5	Numeric Control Usage	47
4.4	Driver Call Log Window	49
4.5	Errors List Window	50
4.6	Module Tab	51
4.7	Sync Tab	53

## 5 Remote Programming

5.1	Introduction	56
5.2	SCPI Programming	56
5.2.1	AgM8192SFP.exe	56
5.3	Programming Recommendations	59
5.4	System Related Commands (SYSTEM Subsystem)	60
5.4.1	:SYSTEM:ERRor[:NEXT]?	60
5.4.2	:SYSTEM:HELP:HEADers?	60
5.4.3	:SYSTEM:LIcense:EXTended:LIST?	61
5.4.4	:SYSTEM:SET[?]	61
5.4.5	:SYSTEM:VERSion?	61
5.4.6	:SYSTEM:COMMunicate:*?	62
5.5	Common Command List	64
5.5.1	*IDN?	64
5.5.2	*CLS	64
5.5.3	*ESE	64
5.5.4	*ESR?	64
5.5.5	*OPC	64
5.5.6	*OPC?	64
5.5.7	*OPT?	64
5.5.8	*RST	65
5.5.9	*SRE[?]	65
5.5.10	*STB?	65
5.5.11	*TST?	65
5.5.12	*LRN?	65
5.5.13	*WAI	65
5.6	Status Model	66
5.6.1	:STATus:PRESet	68
5.6.2	Status Byte Register	68
5.6.3	Questionable Data Register Command Subsystem	69
5.6.4	Operation Status Subsystem	71
5.6.5	Run Status Subsystem	73
5.7	:ARM/TRIGger Subsystem	74
5.7.1	:ABORt	74
5.7.2	:INITiate:CONTinous[:STATe][?] OFF ON 0 1	74
5.7.3	:INITiate:IMMEDIATE	75

5.7.4	:ARM[:SEQuence][:START][:LAYer]:TRIGger:LEVel[?] <level> MINimum MAXimum	75
5.7.5	:ARM[:SEQuence][:START][:LAYer]:TRIGger:IMPedance[?] LOW HIGH	76
5.7.6	:TRIGger[:SEQuence][:START]:BEGin[:IMMediate]	76
5.7.7	:TRIGger[:SEQuence][:START]:BEGin:HWDisable[:STATe][?] 0 1 OFF ON	76
5.8	INSTRument Subsystem	77
5.8.1	:INSTRument:SLOT[:NUMBer]?	77
5.8.2	Multi-module configuration commands	78
5.9	MMEMory Subsystem	80
5.9.1	:MMEMory:CATalog? [<directory_name>]	80
5.9.2	:MMEMory:CDIRectory [<directory_name>]	81
5.9.3	:MMEMory:COpy <string>,<string>[,<string>,<string>]	81
5.9.4	:MMEMory:DELeTe <file_name>[,<directory_name>]	82
5.9.5	:MMEMory:DATA <file_name>,<data>	82
5.9.6	:MMEMory:DATA? <file_name>	82
5.9.7	:MMEMory:MDIRectory <directory_name>	83
5.9.8	:MMEMory:MOVE <string>,<string>[,<string>,<string>]	83
5.9.9	:MMEMory:RDIRectory <directory_name>	83
5.9.10	:MMEMory:LOAD:CSTate <file_name>	84
5.9.11	:MMEMory:STORe:CSTate <file_name>	84
5.10	TEST Subsystem	85
5.10.1	:TEST:PON?	85
5.10.2	:TEST:TST?	85

## 6 Characteristics

6.1	Performance Specification	88
6.2	General	88
6.3	Maintenance	89
6.3.1	ESD Protection	89
6.3.2	Power and Ventilation Requirements	90
6.3.3	Thermal Protection	90
6.3.4	Cleaning Recommendation	90





# 1 Introduction

- 1.1 Document History / 11
- 1.2 Accessories / 12
- 1.3 M8192A Front Panel / 12

## Introduction

This chapter provides an overview of Keysight M8192A module.

The M8192A synchronization module is used together with 2 to 6 M8190A/M8121A modules to build a fully synchronous, phase coherent multi-channel generator system with up to 12 analog channels and 24 marker outputs.

When running in synchronous mode, all of the M8190A/M8121A modules work with the same sample clock and start at the same time. One of the M8190A/M8121A modules is designated as the “master” module and the remaining 1 to 5 modules as “slave”. The common sample clock is derived either from the master module’s internal clock synthesizer or from an external sample clock that is connected to the master module’s sample clock input.

The skew between any two channels is guaranteed to be within +/- 20 ps (without system level calibration) independent of the sample rate. Using the fine delay adjust capability of the M8190A/M8121A with 50 fs resolution, the skew can be adjusted to less than 1 ps between any two channels. Once adjusted, the skew is maintained across loading new waveforms, changing sample rate and power cycles to better than 2 ps.

A common trigger input is available on the synchronization module to trigger all the connected M8190A/M8121A modules simultaneously with deterministic latency. Triggered waveforms have the same inter-channel skew as continuous waveforms. To achieve the lowest possible trigger delay uncertainty, the trigger input can be synchronized externally to the SYNC CLK output.

The M8192A module has its own Soft Front Panel but no extra firmware like the M8190A which allows you to control the trigger mode, trigger level and common start/stop of the multi-module setup.

<b>Features and Benefits</b>	<p>M8192A provides following features and benefits:</p> <ul style="list-style-type: none"> <li>• Synchronization of up to 6 M8190A/M8121A modules (= 12 channels)</li> <li>• One trigger input can trigger up to 6 M8190A/M8121A modules with deterministic latency</li> <li>• Skew repeatability of 2 ps between any two channels – independent of sample rate</li> <li>• Skew resolution of 50 fs between any two channels</li> <li>• 1U AXIe module for high port density</li> </ul>
<b>Additional Documents</b>	<p>Additional documentation can be found at:</p> <ul style="list-style-type: none"> <li>• <a href="http://www.Keysight.com/find/M9505A">http://www.Keysight.com/find/M9505A</a> for 5-slot chassis related documentation.</li> <li>• <a href="http://www.Keysight.com/find/M9502A">http://www.Keysight.com/find/M9502A</a> for 2-slot chassis related documentation.</li> <li>• <a href="http://www.Keysight.com/find/M9045A">http://www.Keysight.com/find/M9045A</a> for PCIe laptop adapter card related documentation.</li> <li>• <a href="http://www.Keysight.com/find/M9047A">http://www.Keysight.com/find/M9047A</a> for PCIe desktop adapter card related documentation.</li> <li>• <a href="http://www.Keysight.com/find/M9536A">http://www.Keysight.com/find/M9536A</a> for embedded AXIe controller related documentation.</li> <li>• <a href="http://www.Keysight.com/find/M8190A">http://www.Keysight.com/find/M8190A</a> for AXIe based AWG module related documentation.</li> <li>• <a href="http://www.Keysight.com/find/M8121A">http://www.Keysight.com/find/M8121A</a> for AXIe based AWG module related documentation.</li> </ul>

## 1.1 Document History

<b>Edition 1.0</b> (October 2013)	Edition 1.0 of the user guide describes the functionality of firmware version 3.0.
<b>Edition 2.0</b> (December 2013)	Edition 2.0 of the user guide describes the functionality of firmware version 3.0.
<b>Edition 3.0</b> (April 2014)	Edition 3.0 of the user guide describes the functionality of firmware version 3.2.
<b>Edition 4.0</b> (November 2014)	Edition 4.0 of the user guide describes the functionality of firmware version 5.0.
<b>Edition 5.0</b> (February 2015)	Edition 5.0 of the user guide describes the functionality of firmware version 5.0.
<b>Edition 6.0</b> (June 2017)	Edition 6.0 of the user guide describes the functionality of firmware version 5.4.
<b>Edition 7.0</b> (October 2017)	Edition 7.0 of the user guide describes the functionality of firmware version 5.4.
<b>Edition 8.0</b> (January 2020)	Edition 8.0 of the user guide describes the M8192A support with M8121A.
<b>Edition 9.0</b> (February 2020)	Edition 9.0 - Removed Win 8.1 support references from the document.

## 1.2 Accessories

The M8192A is delivered with three clock cables and two trigger cables to build a 4-channel synchronous system using two M8190A/M8121A. To synchronize more than two M8190A/M8121A, additional clock and trigger cables must be ordered, as listed in the following table.

**Table 3** Accessories for M8190A/M8121A synchronization

Number of M8190A/M8121A in the Synchronous System	Additional M8192A-801 Clock Cables Needed	Additional M8192A-802 Trigger Cables Needed
2	None	None
3	1	1
4	2	2
5	3	3
6	4	4

## 1.3 M8192A Front Panel

The following figure shows the front panel of the M8192A module:



Figure 1 Front Panel of M8192A

### Inputs/Outputs

The inputs and outputs available on the front panel of the M8192A module are described in Table 4.

**Table 4** Inputs and Outputs available on the front panel of the M8192A module

Input/Outputs	Description	Connector Type
SYS CLK IN	Connect to SYS CLK OUT of the M8190A/M8121A master module	Proprietary multi-coax
SYS CLK OUT	Connect to SYS CLK IN of M8190A/M8121A master module and M8190A/M8121A slave module	Proprietary multi-coax
SYNC CLK OUT	Optional: Connect to external DUT	SMA
TRIGGER IN	Optional: Connect Trigger signal from external DUT for synchronous external triggering across all M8190A/M8121A modules	SMA
TRIGGER OUT	Connect to TRIGGER IN of M8190A/M8121A master module and M8190A/M8121A slave module	QMA

**Status LED**

Two LEDs are available at the front panel to indicate the status of the M8192A module:

The green “**Access**”LED indicates that the controlling PC exchanges data with the M8192A module.

The red “**Fail**”LED has following functionality:

- It is “ON” for about 30 seconds after powering the AXIe chassis.
- After about 30 seconds the LED is switched “OFF”. If an external PC is used to control the AXIe chassis, this PC can be powered after this LED has switched OFF.
- During normal operation of the module this LED is “OFF”. In case of an error condition such as e.g. a self-test error, the LED is switch “ON”.

In case the output relay has shut-off because of an external overload condition, this LED flashes.



# 2 M8192A Installation

2.1 Introduction / 16

2.2 AXI Chasis / 24

## 2.1 Introduction

This chapter explains the steps required to install M8192A module.

### 2.1.1 Pre-Requisites

The following are the pre-requisites for installing Keysight M8192A software:

- The supported operating systems are:
  - Windows 10 (32 bit or 64 bit)
  
- Ensure that you have Keysight IO Libraries Suite Version 16.3 or higher installed on your system. The Keysight IO Libraries Suite can be found on the CD that is part of shipment content or at <http://www.Keysight.com/find/iosuite>.



## 2.1.2 Installation Process

Follow the given steps to install M8192A module on your system:

1. Double-click the executable (*M8192\_Setup.exe*). This executable file will be available on either CD or Web.



2. The Keysight **M8192A Setup** will prepare the InstallShield Wizard for the installation process. The following window will appear.

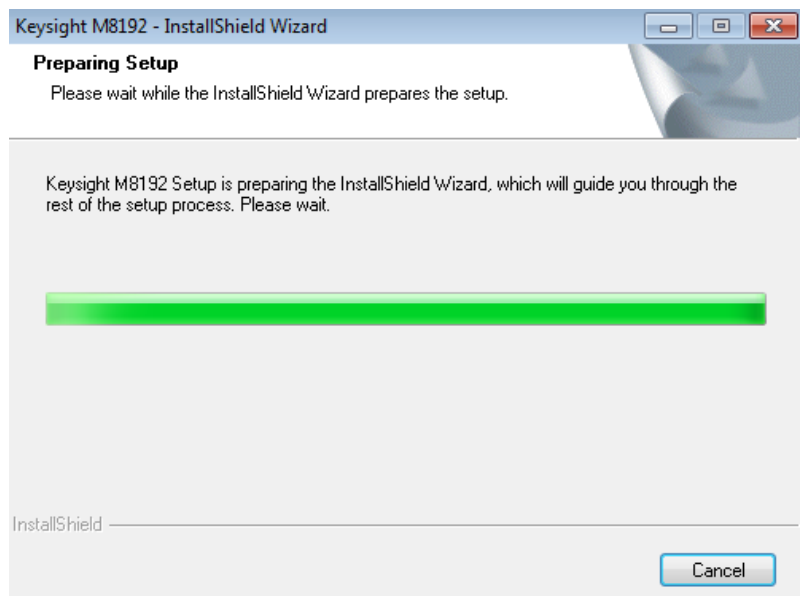

3. Follow the onscreen instructions to begin the installation process. Click **Next**.

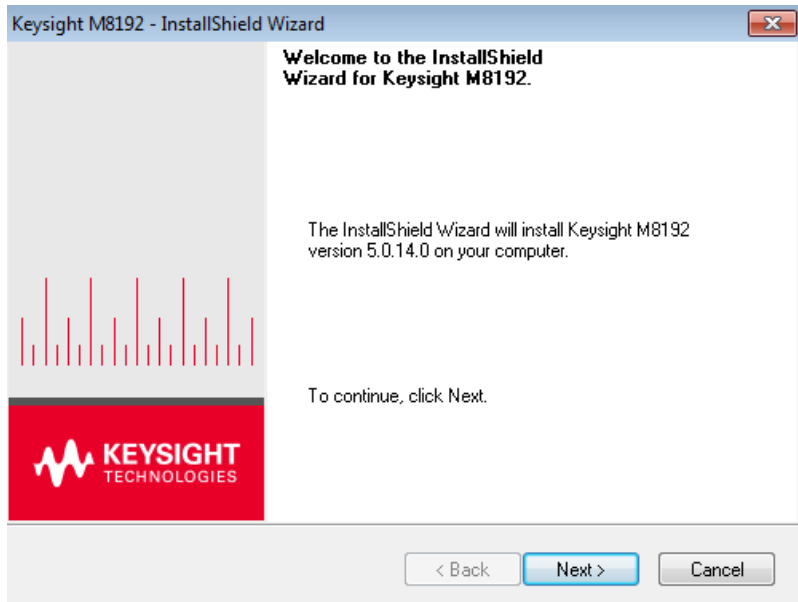

4. We recommend you read the document to check if your hardware configuration is supported.  
Click **Next** to proceed to the license agreements.

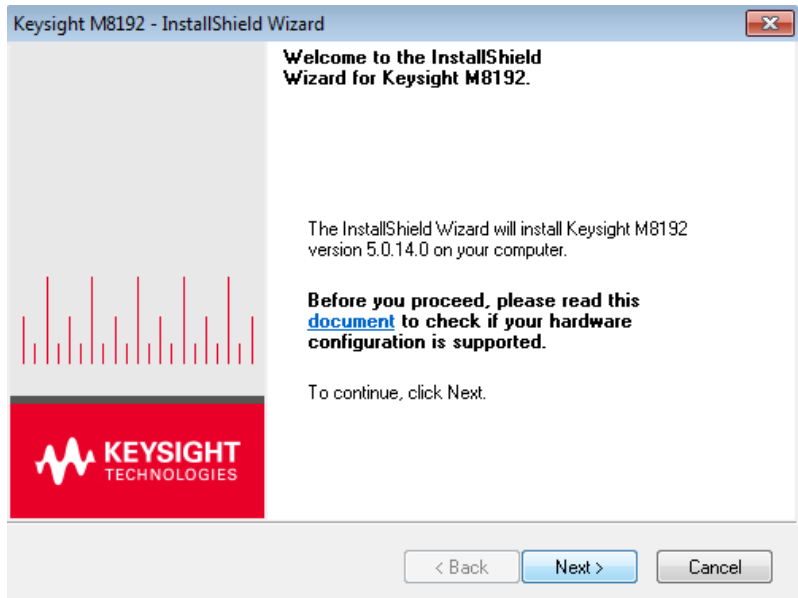

5. Accept the terms of Keysight software end-user license agreement. Click **Next**.

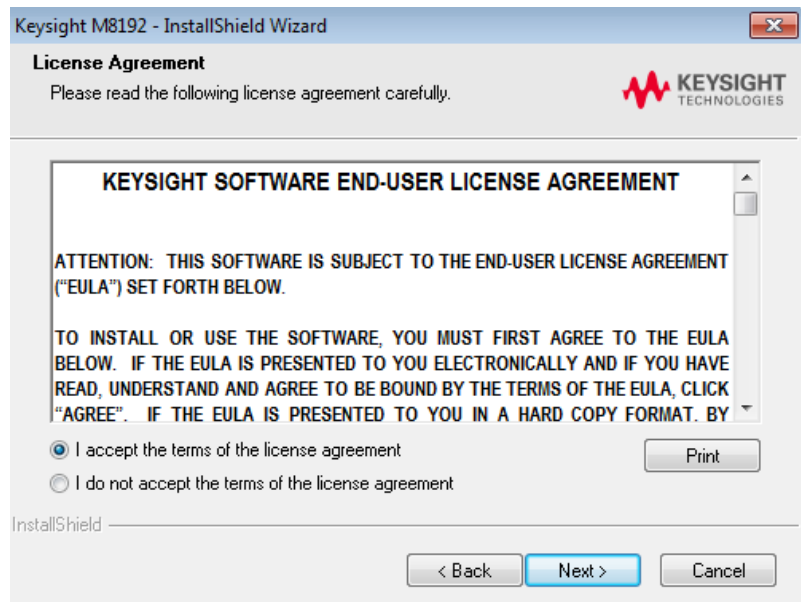

6. Accept the terms of Keysight IVI Driver Source Code license agreement. Click **Next**.

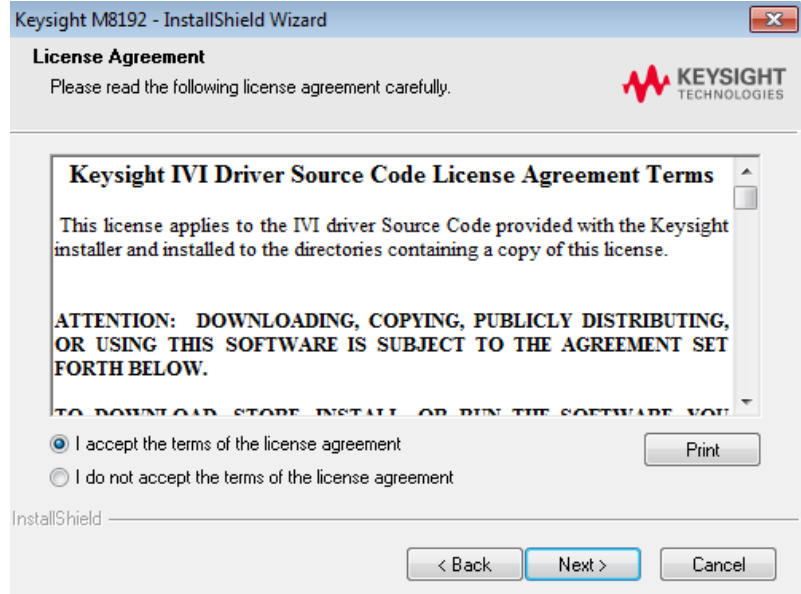

7. Select **Yes** if you want to read the post-installation instructions.  
Click **Next**.

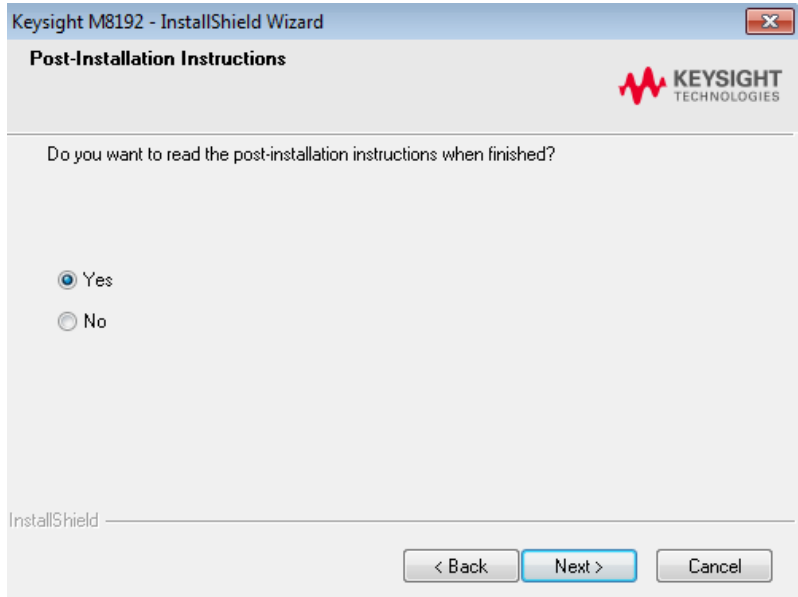

8. Select a setup type either **Complete** or **Custom**.  
Click **Next**.

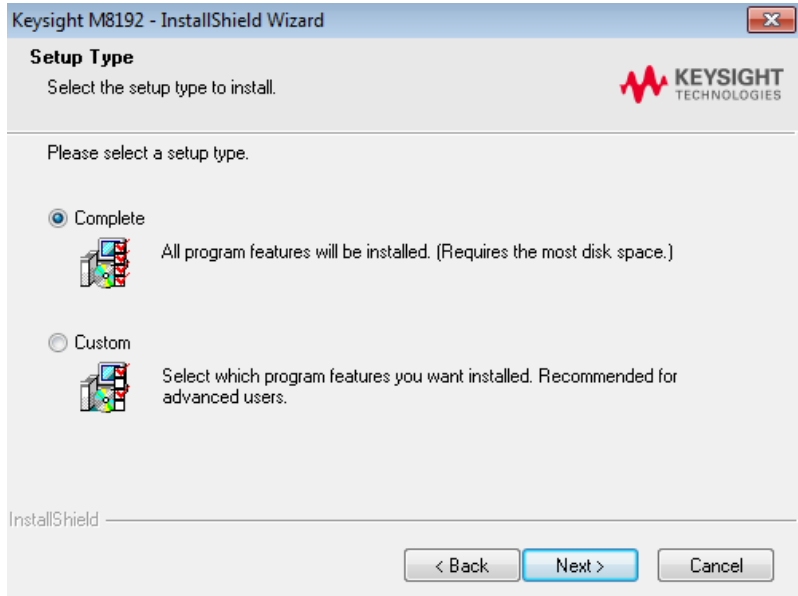

9. Click **Install** to begin installation.

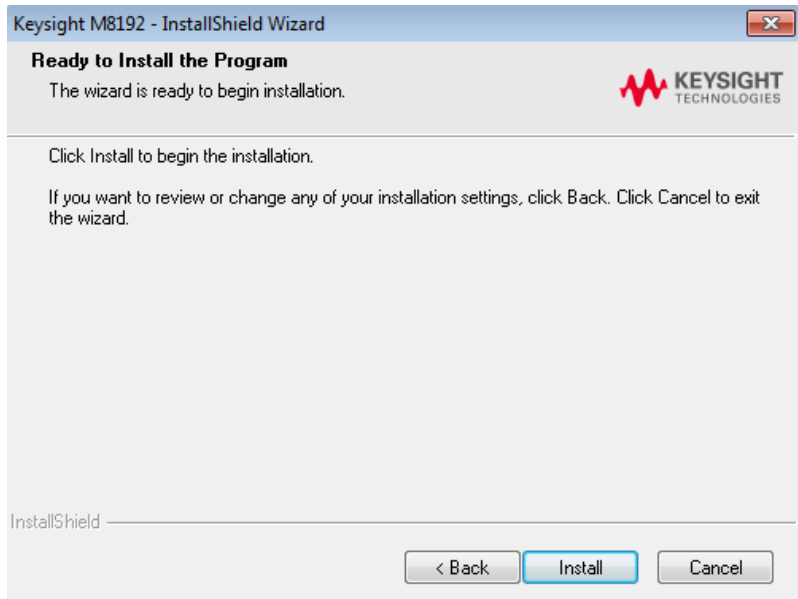

10. The Keysight M8192A will configure the new software installation.

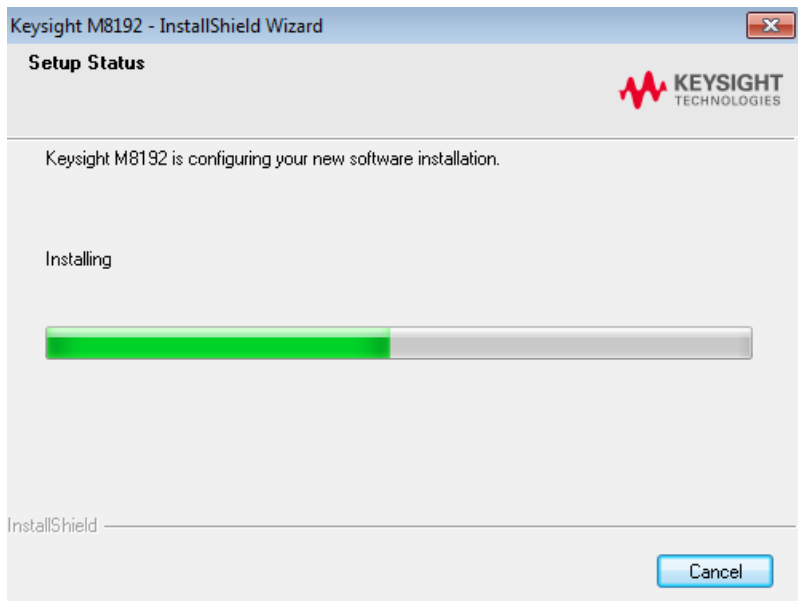

11. The following screen will appear once the Keysight M8192A software is successfully installed on your system. Click **Finish** to restart your system.

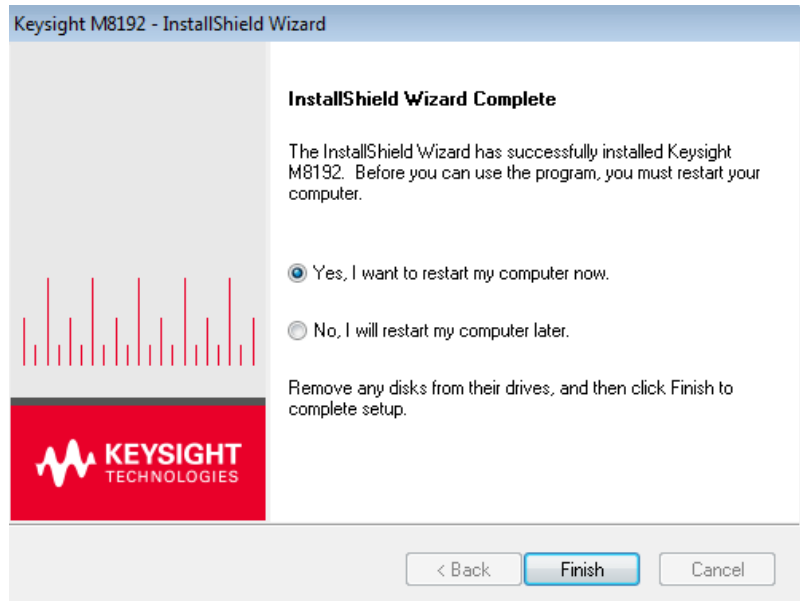

This completes the Keysight M8192A software installation.

### 2.1.3 Post Installation Steps

**NOTE**

If your instrument is already powered up and connected to your PC using the PCIe cable, just reboot your PC and start with step 5.

---

Follow the post installation steps as shown below:

1. Shut down PC and instrument.
2. Connect instrument to PC using the PCIe cable.
3. Switch on instrument. Wait until the “Access” LED of the M8192A has switched from red to green.
4. Switch on PC.
5. The PC should automatically recognize the instrument.  
Check this in the device manager; e.g. via *Computer* → *Manage* → *Device Manager*:  
The instrument should be visible in the device tree as *Keysight* → *M8192*.

**NOTE**

Your PC might request a reboot. Reboot your PC, if requested.

---

6. Check if the M8192 is also visible in the Keysight Connection Expert:  
e.g. via *Start Menu* → *Keysight IO Libraries Suite* → *Keysight Connection Expert*.  
If something went wrong and the Instrument is not shown in the PXI section, it may be necessary to reboot the PC once more.

## 2.1.4 How to Control the Instrument

To control the instrument:

1. Start the Soft Front Panel (**Start > All Programs > Keysight > M8192 > M8192 Soft Front Panel**).
2. A dialog will open, in which you can select your instrument.
3. Add Keysight M8190A/M8121A instruments to the system and connect them to the M8192.
4. Use **Help > About** to get information about available remote connections.

## 2.2 AXI Chassis

The detailed documentation for the AXIe chassis can be found at:

- <http://www.Keysight.com/find/M9505A> for 5-slot chassis
- <http://www.Keysight.com/find/M9502A> for 2-slot chassis.

### 2.2.1 ESM Front Panel Connector

The ESM Front Panel Connector is shown in the figure below:

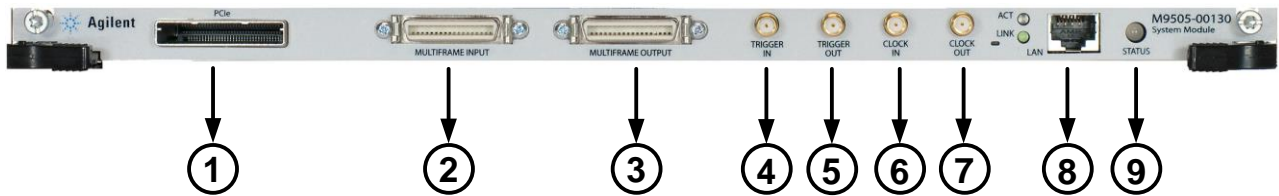



1	PCIe	Connects a host PC to the chassis via PCIe. PCIe is the only interface that can be used to control the M8192A module.
2	Multiframe Input	Synchronizes timing signals with multiple daisy-chained chassis.
3	Multiframe Output	These signals are not needed to synchronize M8190A/M8121A modules. The M8192A synchronization module is needed instead.
4	Trigger In	External Trigger connections.
5	Trigger Out	The Trigger In of the AXle ESM cannot be used to trigger the M8192A. The M8192A has its own Trigger In. The Trigger Out of the AXle ESM cannot be controlled by the M8192A.
6	Clock In	External clock connections.
7	Clock Out	
8	LAN	Connects the host PC to the chassis, via 10/100/1000 Ethernet. In particular, the LAN connector is used for ESM configuration, but NOT to communicate to the M8192A.
9	Status Light	Indicates the chassis status.



# 3 System Configuration

- 3.1 Introduction / 28
- 3.2 Supported AXle Frame Combinations / 29
- 3.3 Controlling One AXle Chassis / 31
- 3.4 Controlling Multiple AXle Chassis / 33
- 3.5 Synchronous System Cabling / 36
- 3.6 Controlling the Synchronous System / 37

## 3.1 Introduction

This chapter describes how to configure a synchronous system. The term ‘synchronous system’ describes multiple M8190A/M8121A AWG modules that operate entirely synchronous with respect to timing parameters including synchronous start, synchronous sequencing, common trigger and common sample clock. A synchronous system consists of:

- M8192A synchronization module
- One M8190A/M8121A AWG master module
- One or up to five M8190A/M8121A AWG slave modules
- One or more M9502A 2-slot AXIe chassis or M9505A 5-slot AXIe chassis
- An external PC to control the synchronous system
- Trigger cables and clock cables to synchronize all modules in the system
- M8192A software that controls the synchronous operation of the system

### NOTE

Any M8190A/M8121A module may become a master module or slave module by software configuration and by connecting external cables accordingly.

The M8192A synchronization module is designed to synchronize up to six M8190A/M8121A arbitrary waveform generator modules. The M8190A/M8121A modules can be in the same or different AXIe chassis as the M8192A. This allows very flexible configurations to address a variety of applications.

A synchronous trigger signal to start the system synchronously and a common clock signal is distributed using special cables. These cables are connected on the front panel between the M8192A synchronization module and the M8190A/M8121A arbitrary waveform generator modules.

All synchronous system configurations require an external desktop PC or laptop PC with PCIe interface cable connection to control the system. In case of multiple AXIe chassis configurations, a desktop PC with two or even three PCIe adapters is required.

Any even and odd number of up to 12 Arbitrary Waveform Generator channels can be configured using a combination of 1-channel and 2-channel M8190A/M8121A Arbitrary Waveform Generators (see section 3.2). Typical multi-channel configurations are described in the following subchapters:

### 3.1.1 4 M8190A/M8121A Arbitrary Waveform Generator Channels

To configure a synchronous system with 4 channels, use one 5-slot AXIe chassis, one M8192A and two M8190A/M8121A 2-channel Arbitrary Waveform Generator modules.

This configuration can be ordered as a pre-configured M8190A/M8121A's multi-channel AWG system.

### 3.1.2 6 (or 8) M8190A/M8121A Arbitrary Waveform Generator Channels

To configure a synchronous system with 6 (or 8) channels, use two 5-slot AXIe chassis, one M8192A and 3 (or 4) M8190A/M8121A 2-channel Arbitrary Waveform Generator modules. This synchronous system can be controlled from one external PC that supports two PCIe adapter cards.

This 8-channel configuration can be ordered as a pre-configured M8190A/M8121A's multi-channel AWG system.

### 3.1.3 10 (or 12) M8190A/M8121A Arbitrary Waveform Generator Channels

To configure a synchronous system with 10 (or 12) channels, use three 5-slot AXIe chassis, one M8192A and 5 (or 6) M8190A/M8121A 2-channel Arbitrary Waveform Generator modules. This synchronous system can be controlled from one external PC that supports three PCIe adapter cards.

## 3.2 Supported AXIe Frame Combinations

Besides the typical and most common synchronous system configurations described in chapter 3.1 the synchronous system configuration is not limited to these examples. A general configuration of a synchronous system can be configured by a combination of up to seven M9502A 2-slot AXIe chassis and M9505A 5-slot AXIe chassis.

The trigger and clock cables needed for the synchronous system are limited in physical length. As a result, when using three or more AXIe chassis to configure a synchronous system, the M8192A synchronization module must be inserted in the middle AXIe chassis.

Due to limited physical length of the trigger cables and clock cables, synchronous systems as listed in Table 5 can be configured.

**Table 5 Valid Synchronous System Configurations**

Number of M8192A	Number of M8190A/M8121A	Supported AXle Chassis Combinations
1	2	Three M9502A 2-slot AXle chassis or One M9505A 5-slot AXle chassis or Two M9505A 5-slot AXle chassis
1	3	Four M9502A 2-slot AXle chassis or One M9505A 5-slot AXle chassis plus one M9502A 2-slot AXle chassis or Two M9505A 5-slot AXle chassis
1	4	Five M9502A 2-slot AXle chassis or One M9505A 5-slot AXle chassis plus two M9502A 2-slot AXle chassis or Two M9505A 5-slot AXle chassis
1	5	Six M9502A 2-slot AXle chassis or One M9505A 5-slot AXle chassis plus three M9502A 2-slot AXle chassis or Two M9505A 5-slot AXle chassis plus one M9502A 2-slot AXle chassis
1	6	Seven M9502A 2-slot AXle chassis or One M9505A 5-slot AXle chassis plus four M9502A 2-slot AXle chassis or Two M9505A 5-slot AXle chassis plus two M9502A 2-slot AXle chassis or Three M9505A 5-slot AXle chassis

### 3.3 Controlling One AXIe Chassis

This section describes the basic configuration of a synchronous system with four synchronous M8190A/M8121A AWG channels, however Figure 2 displays the configuration with M8190A.

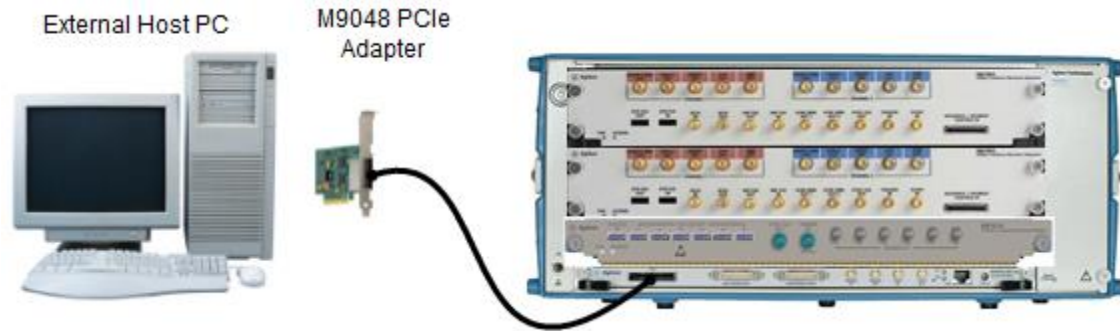

Figure 2 One AXIe chassis connected to external host PC

A synchronous system with four synchronous M8190A/M8121A AWG channels consists of:

- Two M8190A/M8121A 2-channel arbitrary waveform generator modules
- M8192A synchronization module. The delivery content of the M8192A synchronization module includes:
  - Three clock cables with proprietary multi-coax connectors at each side. See Figure 3.
  - Two trigger cables with a QMA connector at one end and a SMA connector at the other end. See Figure 4.
- M9505A AXIe chassis
- External controlling PC including PCIe IF card and PCIe cable

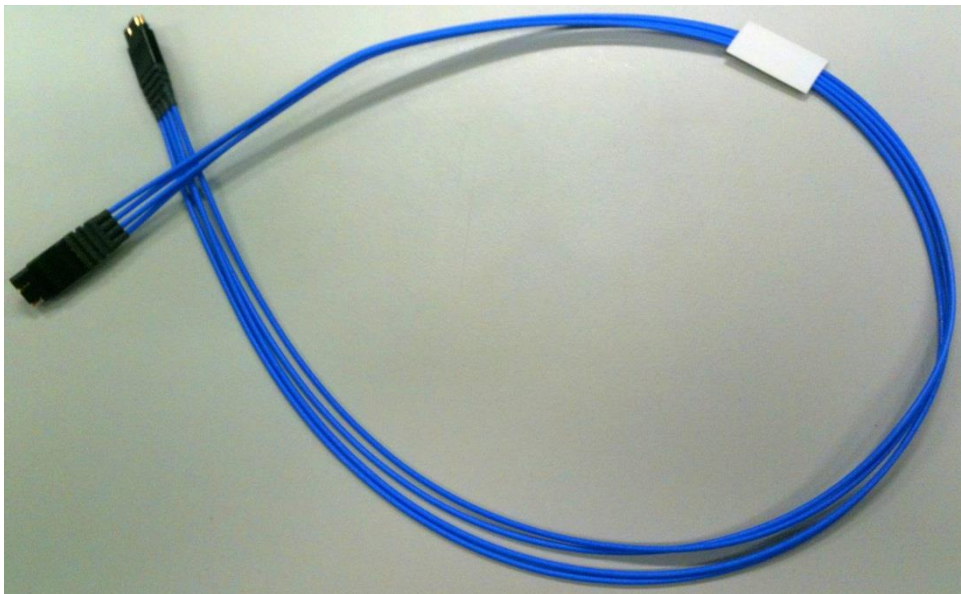

Figure 3 M8192A-801 proprietary multi-coax clock cable



Figure 4 M8192A-802 QMA to SMA trigger cable



### 3.4 Controlling Multiple AXIe Chassis

A synchronous system that consists of multiple (more than one) AXIe chassis can be controlled in the following two ways:

- One PC controls multiple chassis
- Multiple PCs control multiple chassis

#### 3.4.1 One PC Controls Multiple Chassis

If you are using multiple AXIe chassis (any combination of the Keysight M9502A 2-Slot or M9505A 5-Slot chassis) connected to your PC, Keysight Connection Expert finds both the chassis at the same local IP address (TCPIP0::169.254.1.0::5052:SOCKET). Refer to Figure 5.



Figure 5 Multiple AXIe chassis connected to external host PC

Keysight Connection Expert finds both chassis but since the IP addresses are the same, it is impossible to use the Chassis Web Interface, Soft Front Panel, or specify a chassis for programming.

If you have two or more AXIe chassis, the solution is to connect them to an optional switch or hub as shown in Figure 6.

In this scenario, the Host PC must connect to the same network hub or switch as the AXIe chassis.

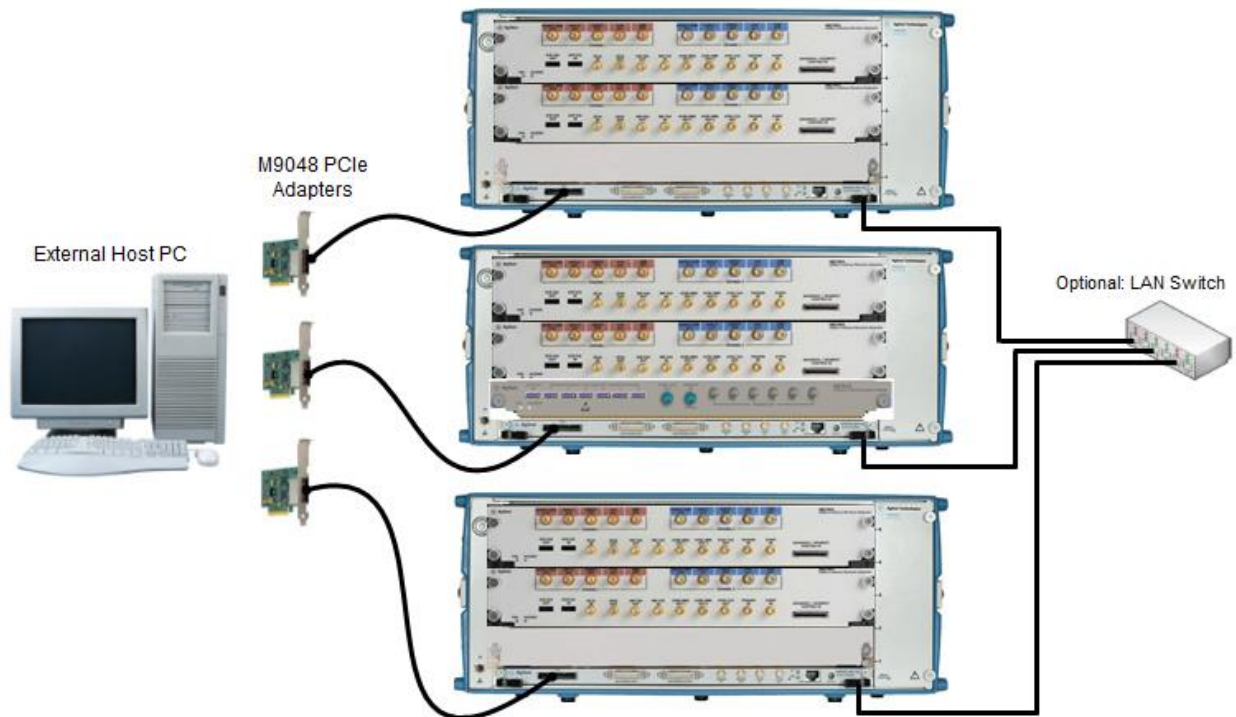

Figure 6 Using a LAN switch for multiple AXIe chassis

Although it is not required, manually assigned a unique, static IP address in the optional switch, will speed up network resolution at Windows startup and eliminate any potential network resolution issues.

### 3.4.2 Multiple PC Controls Multiple Chassis

The configuration where multiple PCs are used to control multiple AXIe chassis may be used to increase the data throughput over each PCIe link from the host PC to the AXIe chassis. Streaming applications that require multiple synchronous AWG channels can exploit this type of configuration to increase the streaming throughput to each AWG channel.

If you have multiple PCs that are connected to multiple AXIe chassis, each PC controls one AXIe chassis over PCIe using an M9048A PCIe IF card.

The “Master” PC that controls the M8192A over PCIe, controls the “Slave” PCs using the LAN IF card.

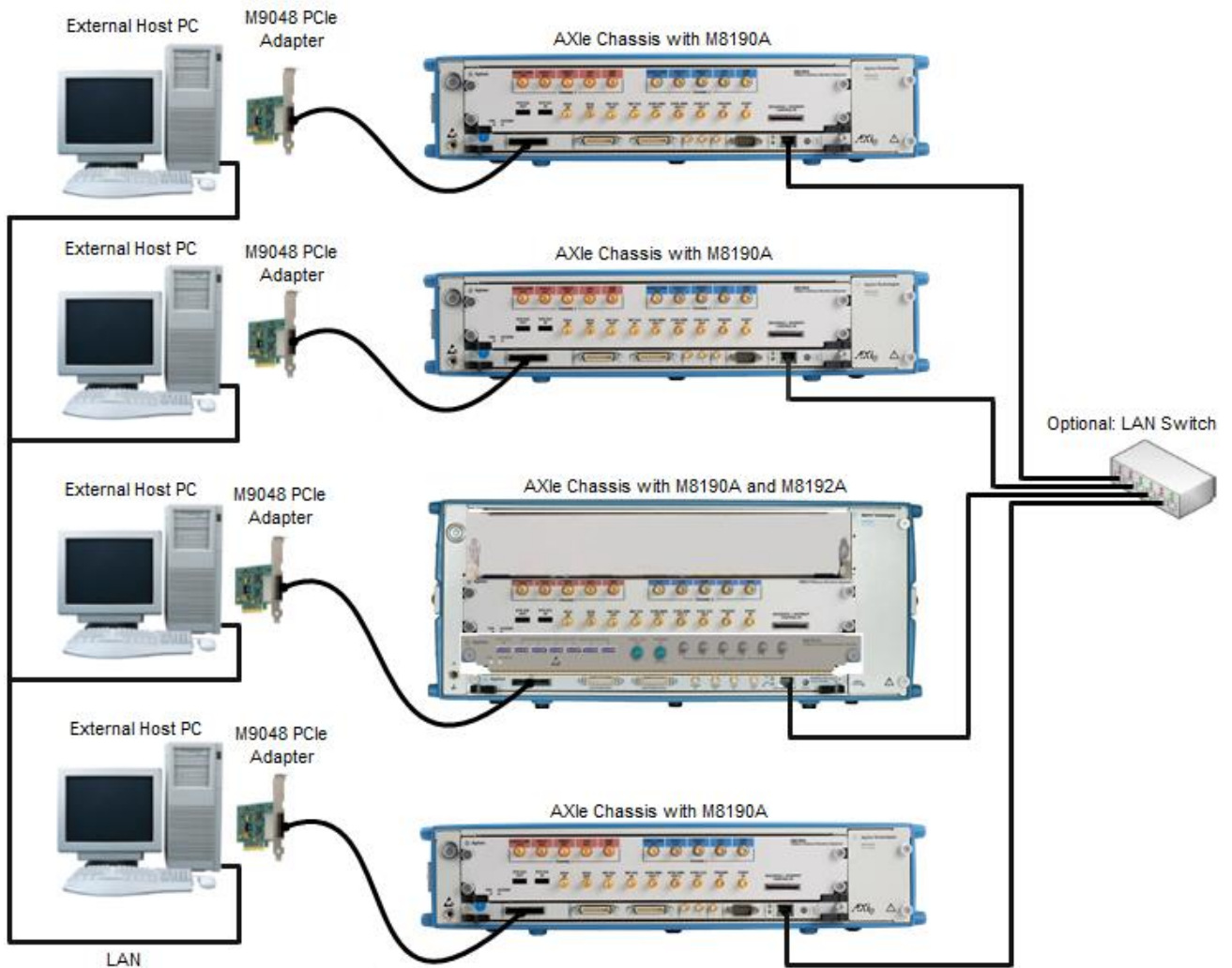

Figure 7 Multiple PCs controls multiple AXIe chassis

#### NOTE

Figure 7 displays the configuration with M8190A module, similar configuration can be done using the M8121A module.

### 3.5 Synchronous System Cabling

This section describes the cable connections of an eight-channel synchronous system. An eight-channel synchronous system consists of:

- Four M8190A/M8121A 2-channel arbitrary waveform generator modules
- M8192A synchronization module. The delivery content of the M8192A synchronization module includes:
  - Five clock cables with proprietary multi-coax connectors at each side.
  - Four trigger cables with a QMA connector at one end and a SMA connector at the other end.
- Two M9505A AXIe chassis
- External controlling PC including PCIe IF card and PCIe cable

Figure 8 depicts the eight-channel synchronous system cabling.

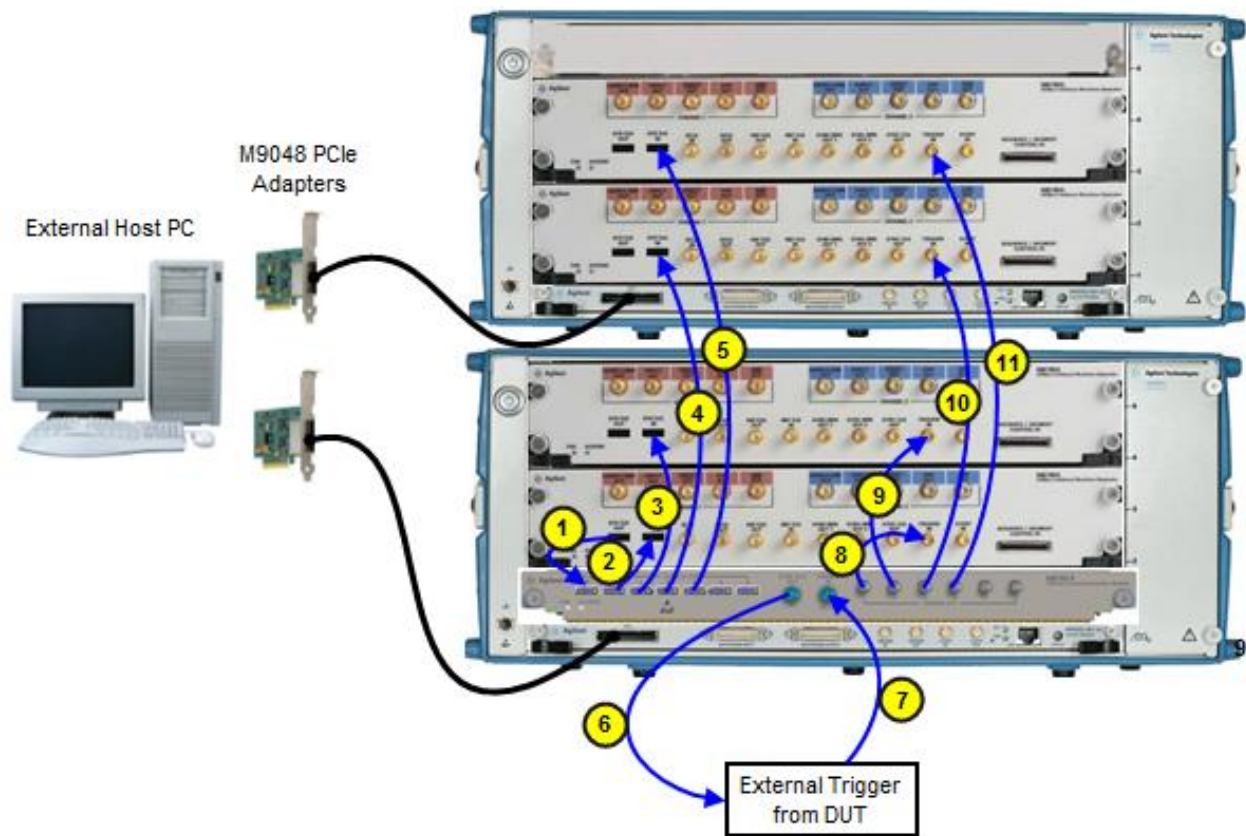

Figure 8 System level cabling of an eight-channel synchronous system

The highlighted cables in the synchronous system cabling are described in

**Table 6.**

**Table 6 Cable Connections**

Cable No.	Cable Type	Source	Destination
1	Proprietary multi-coax	Master module: SYS CLK OUT	Sync module: SYS CLK IN
2	Proprietary multi-coax	Sync module: SYS CLK OUT	Master module: SYS CLK IN
3-5	Proprietary multi-coax	Sync module: SYS CLK OUT	Up to 5 slave modules: SYS CLK IN
6	SMA to SMA	Sync module: SYNC CLK OUT	Device Under Test (DUT)
7	SMA to SMA	Device Under Test (DUT)	Sync module: Trigger IN
8	QMA to SMA	Sync module: TRIGGER OUT	Master module: Trigger IN
9-11	QMA to SMA	Sync module: TRIGGER OUT	Up to 5 slave modules: Trigger IN

## 3.6 Controlling the Synchronous System

This section describes the ways to control the synchronous system.

### 3.6.1 Requirements for Controlling the Synchronous System

The requirements for controlling the synchronous system are as follows:

- Any remotely controlled M8190A/M8121A module that will become part of the synchronous system must be made visible in ACE (Keysight Connection Expert)
- The M8190A/M8121A firmware of each module of the synchronous system must be started prior to configuring the synchronous system.
- SYS CLK outputs of the M8192A must be used in ascending order without leaving a gap. Example: For four M8190A/M8121A, SYSCLK OUT 1, SYSCLK OUT 2, SYSCLK OUT 3 and SYSCLK OUT 4 must be connected.

### 3.6.2 Synchronous System Operation Modes

The synchronous system has the following two modes of operation:

1. Configuration mode
2. Operation mode

### 3.6.2.1 Configuration Mode

The configuration mode is used while connecting external cables of the synchronous system or during configuration of main parameters such as setting the common sample clock frequency that affects the entire synchronous system. Specifically, when defining which M8190A/M8121A found by Keysight Connection Expert (ACE) modules belong to the synchronous system or to determine which M8190A/M8121A is the master module or a slave module or when system parameters (see section 3.6.3.2) are being changed, the system must be stopped and set in configuration mode:

### 3.6.2.2 Operation Mode

The operation mode is used for data generation and to synchronously start the system. To start data generation, you must switch to operation mode.

Whenever the user switches from configuration mode to operation mode, following system checks and actions are performed:

- Verify that the firmware version of all M8190A/M8121A AWG modules and the M8192A synchronization module of the synchronous system is identical and higher than V3.0.0
- Verify that each M8190A/M8121A of the synchronous system has a common set of options. E.g. all M8190A/M8121A of the synchronous system must operate in the same bit mode. I.e. when operating the synchronous system in 14-bit mode, option -14B must be installed on each M8190A/M8121A of the synchronous system. When operating the synchronous system in interpolation mode, option -DUC must be installed on each M8190A/M8121A of the synchronous system.
- Each M8190A/M8121A in the synchronous system measures the frequency of the sample clock and synchronization clock. As a result, correct cabling of the clock cables is verified.
- Verify that a trigger propagates from the M8192A synchronization module to each M8190A/M8121A of the synchronous system. As a result, correct cabling of the trigger cables is verified.
- Transfer the settings of sample frequency, bit mode (including interpolation factor) to the slave modules.
- Set arm mode of all the modules in the synchronous system to “Armed”.
- Set trigger mode of all the modules in the synchronous system identical to the trigger mode of the controlling M8192A module.
- Perform accurate delay alignment among all M8190A/M8121A channels in the synchronous system.

### 3.6.3 Control Parameters

In a synchronous system, many parameters such as the common sample clock frequency cannot be adjusted individually on each M8190A/M8121A AWG module. Otherwise, synchronous operation would not be possible. This section describes how to control parameters that affect the entire synchronous system. This section describes as well if a specific system parameter is modified by the M8192A or the M8190A/M8121A.

#### 3.6.3.1 Using M8192A Soft Front Panel

The Soft Front Panel of the M8192A lists all M8190A/M8121A that are available in the local PC or in ACE in a table. Using this table, the user can define that a certain M8190A/M8121A will be,

- Part of the synchronous system (or will not be part)
- The master module
- The slave module

Following parameters can be controlled using the M8192A Soft Front Panel:

- Trigger mode
- Trigger threshold
- Trigger input impedance
- Trigger input enable
- Synchronous start and stop of all M8190A/M8121A modules in the system by software

#### 3.6.3.2 Using M8190A Soft Front Panel

The following parameters that affect the entire synchronous system can be controlled from the M8190A master module.

- Sample Clock Frequency
- Sample Clock Source (Internal or External)
- Reference Clock Source (Backplane, Reference CLK In, Internal)
- Output Mode (14bit or 12 bit or interpolation mode and interpolation factor)

Above parameters are disabled in the M8190A slave modules. To modify above parameter, you need to switch to configuration mode first.

### 3.6.3.3 Using M8121A Soft Front Panel

The following parameters that affect the entire synchronous system can be controlled from the M8121A master module.

- Sample Clock Frequency
- Sample Clock Source (Internal or External)
- Reference Clock Source (Backplane, Reference CLK In, Internal)
- Output Mode (14bit or 12 bit or interpolation mode and interpolation factor)

Above parameters are disabled in the M8121A slave modules. To modify above parameter, you need to switch to configuration mode first.

### 3.6.3.4 Parameters controlled from M8192A and M8190A/M8121A

The Table 7 lists the common synchronous system parameters that can be controlled by the M8192A or M8190A/M8121A.

**Table 7 Parameters controlled from M8192A and M8190A/M8121A**

Functionality	M8192A Synchronization Module	M8190A/M8121A Master Module	M8190A/M8121A Slave Module
Sample frequency	Not available	Controls all M8190A/M8121A. Modification is only possible in configuration mode	Disabled
Output Mode :14 bit or 12 bit or interpolation mode (INTx3, INTx12, INTx24 or INTx48)	Not available	Controls all M8190A/M8121A. Modification is only possible in configuration mode	Disabled
Coupling between channels	All M8190A/M8121A always operate in coupled mode	Coupled mode is always turned on by the M8192A and uncoupled mode is disabled	Coupled mode is always turned on by the M8192A and uncoupled mode is disabled
Arm mode	All M8190A/M8121A must operate in arm mode 'self' (arm mode 'armed' is not supported)	Arm mode 'armed' is disabled	Arm mode 'armed' is disabled
Trigger mode	All M8190A/M8121A must operate in triggered or continuous mode (gated is not enabled)	Gated is not selectable	Gated is not selectable
Trigger Threshold	Affects all M8190A/M8121A	Disabled	Disabled
Trigger Impedance	Affects all M8190A/M8121A	Disabled	Disabled
Trigger Input Enable/Disable	Affects all M8190A/M8121A	Disabled	Disabled
Force trigger	Affects all M8190A/M8121A	Locally available for debugging	Locally available for debugging
Force event	Not available	Locally available for debugging	Locally available for debugging
Run/Stop	Enhanced by: Armed, Trigger, Armed & Trigger, Stop	Disabled	Disabled



# 4 M8192A Soft Front Panel

- 4.1 Introduction / 42
- 4.2 Launching the M8192A Soft Front Panel / 42
- 4.3 M8192A Soft Front Panel / 44
- 4.4 Driver Call Log Window / 49
- 4.5 Errors List Window / 50
- 4.6 Module Tab / 51
- 4.7 Sync Tab / 53

## 4.1 Introduction

This chapter describes the M8192A Soft Front Panel (SFP).

## 4.2 Launching the M8192A Soft Front Panel

There are three ways to launch the M8192A Soft Front Panel. They are as following:

1. From the *Start Menu*, select *All Programs* → *Keysight* → *M8192* → *M8192 Soft Front Panel*.
2. From the *Keysight Connection Expert*, select the discovered M8192 module, press the right mouse key to open the context menu and select “*Send Commands To This Instrument*”.
3. From the *Keysight Connection Expert*, select the discovered M8192 module, select the “*Installed Software*” tab and press the “*Start SFP*” button.

The following screen will appear:

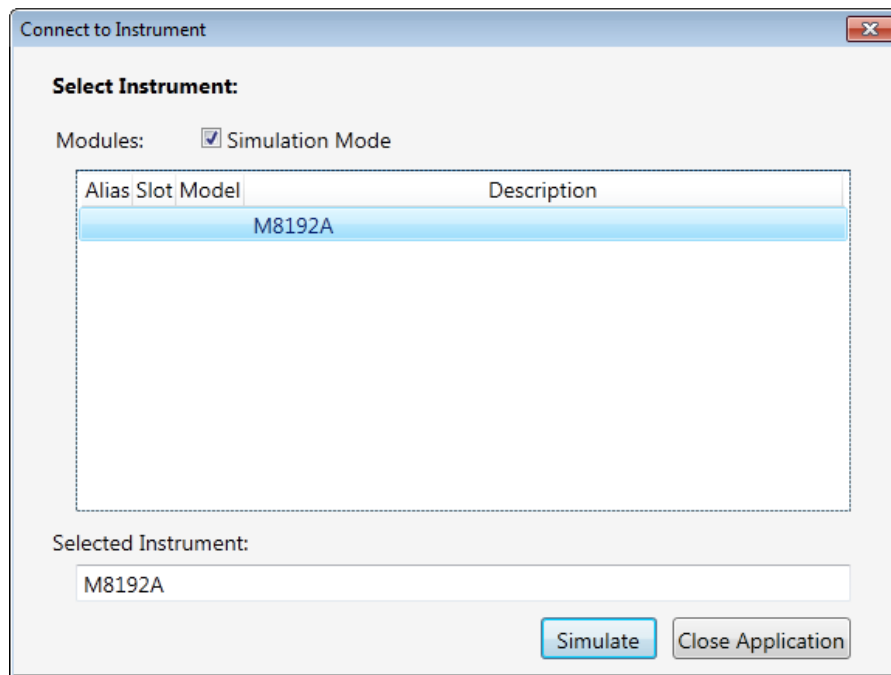

Figure 9 M8192A connected to PC

The instrument selection dialog shows the addresses of the discovered M8192A modules. Select a module from the list and press “Connect”.

If no M8192A module is connected to your PC, you can check “Simulation Mode” to simulate an M8192A module.

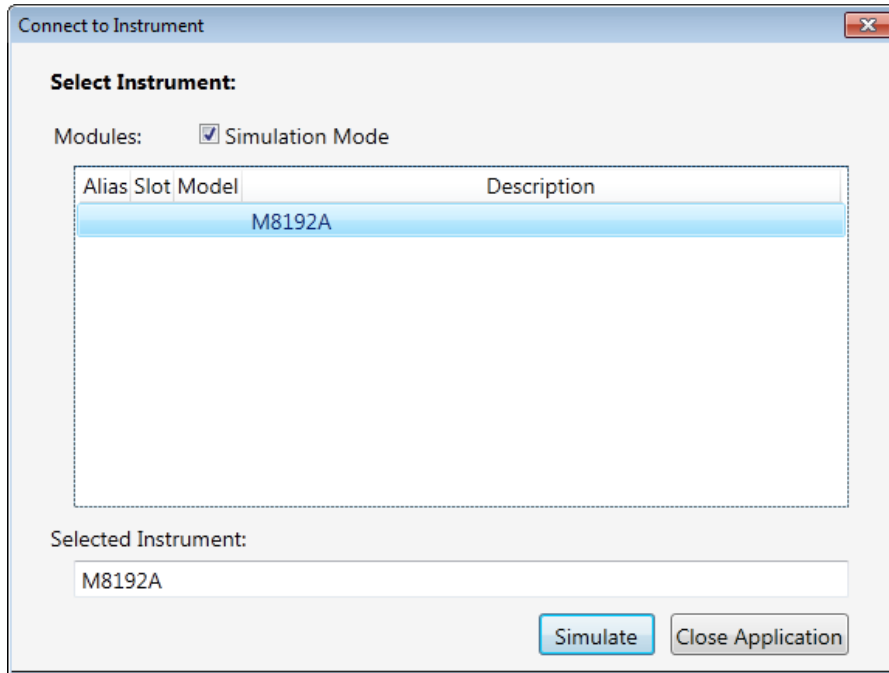

Figure 10 M8192A connected in simulation mode

### 4.3 M8192A Soft Front Panel

The M8192A Soft Front Panel allows you to:

- Configure a multi-module group,
- Control the M8192 trigger input parameters,
- Synchronously start all channels of the multi-module group.

It includes the following GUI items:

- Title Bar
- Menu Bar
- Status Bar
- Tabs (Module, Sync)

The detailed information on these GUI items is described in the sections that follow.

### 4.3.1 Title Bar

The title bar contains the standard Microsoft Windows elements such as the window title and the icons for minimizing, maximizing, or closing the window.

### 4.3.2 Menu Bar

The menu bar consists of various pull down menus that provide access to the different functions and launch interactive GUI tools.

The menu bar includes the following pull down menu:

- File
- View
- Utilities
- Tools
- Help

Each pull down menu and its options are described in the following sections.

#### 4.3.2.1 File

The *File* menu includes the following selections:

- File → Connect...  
Opens the instrument selection dialog.
- File → Save Configuration As...  
Saves configuration as a text file.
- File → Load Configuration...  
Load the previously saved configuration file.
- File → Exit  
Exits the soft front panel.

### 4.3.2.2 View

The *View* menu includes the following selections:

- View → Refresh  
Reads the instrument state and updates all fields.
- View → Hide  
Minimize the M8192A to notification icon.

### 4.3.2.3 Utilities

The *Utility* menu includes the following selections:

- Utility → Reset  
Resets the instrument, reads the state and updates all fields.
- Utility → Self Test...  
Opens the “*Self Test*” window to start the self-test and display the result after completion.

### 4.3.2.4 Tools

The *Tools* menu includes the following selections:

- Tools → Monitor Driver Calls  
Opens the “*Driver Call Log*” window.

### 4.3.2.5 Help

The *Help* menu includes the following selections:

- Help → User Guide  
Opens the M8192A user guide.
- Help → Driver Help  
Opens the IVI driver online help.
- Help → Online Support  
Opens the instrument's product support web page.
- Help → About  
Displays revision information for hardware, software and firmware. Displays the serial number of the connected module.

### 4.3.3 Status Bar

The *Status Bar* contains the following two fields from left to right:

- Connection Status
  - “Not Connected” – No instrument is connected.
  - “Connected: <Instrument resource string>” – An instrument is connected. The resource string, for example PXI36::0::0::INSTR is displayed.
  - “Simulation Mode” – No real instrument is connected. The user interface is in simulation mode.  
Click this field to open the “*Connect to Instrument*” dialog.
- Error status
  - “Error” – The connected instrument reported an error.
  - “No Error” – No errors occurred.  
Click this field to open the “*Error*” window.

### 4.3.4 Tabs (Module/Sync Tabs)

These tabs are used to configure the most important parameters of the M8192A module.

### 4.3.5 Numeric Control Usage

The numeric control is used to adjust the value and units. Whenever you bring the mouse pointer over the numeric control, a tooltip appears which shows the possible values in that range.



Figure 11 Tooltip showing possible values in the range

The numeric controls can be used in the following ways:

- Use the up/down arrows to change the value. The control automatically stops at the maximum/minimum allowed value.
- You can increase or decrease the value starting at a specific portion of the value. To do this, place the cursor to the right of the targeted digit and use the up/down arrows. This is especially useful when changing a signal characteristic that is immediately implemented, and observing the result in another instrument. For example, you can change the signal generator's frequency by increments of 10 MHz and observe the measured result in a signal analyzer:



Figure 12 Typing directly into the field

- Type directly into the field and press the Enter key. If you enter a value outside the allowed range, the control automatically limits the entered value to the maximum or minimum allowed value.
- When you type the value, you can type the first letter of the allowed unit of measure to set the units. For example, in the Frequency control you can use "H", "K", "M", or "G" to specify hertz, kilohertz, megahertz, or gigahertz, respectively. (The control is not case sensitive.)

The controls allow scientific notation if it is appropriate to the allowed range. Type the first decimal number, enter an "E", and omit any trailing zeroes. For example, in the Frequency control you can type 2.5e+9 and press Enter to set the frequency to 2.5 GHz. (The plus sign is automatically inserted if it is omitted.)



## 4.4 Driver Call Log Window

Use this window to inspect the sequence of SCPI commands used to configure the M8192A module.

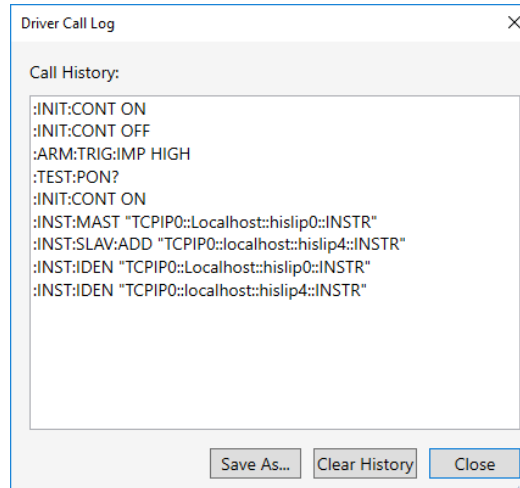

Figure 13 Driver Call Log Window

It has the following buttons:

- Save As...  
Saves the Driver Call Log as a text file.
- Clear History  
Clears the Driver Call Log.
- Close  
Exits the window.

## 4.5 Errors List Window

Use this window to view errors, warnings, and information.

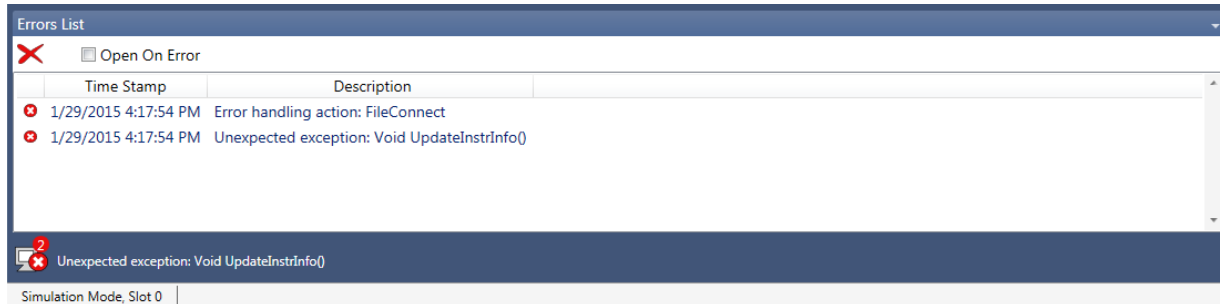









Figure 14 Errors List Window

It has the following controls, signs, and columns:

1.  Open On Error  
Select this check box to automatically open the errors list window whenever an error occurs. This window will show error details i.e time stamp and description.
2.  (Clear All)  
Use this option to clear all the errors from the errors list window.
3.  or  (Hide Errors List Window or Show Errors List Window)  
Use this toggle option to respectively show or hide the errors list window. It also shows total number of errors in the list. When the window has no errors, the green tick icon will appear.
4.  (Error)  
This icon represents an error.
5.  (Warning)  
This icon represents a warning.
6.  (Information)  
This icon represents an information.
7. Time Stamp  
This column lists the time stamp of individual errors in the format: DD/MM/YYYY HH:MM:SS.
8. Description  
This column provides the description of individual errors.
9.  (Window Controls)  
This drop down list provides window control options like:
  - Float
  - Dock
  - Auto Hide
  - Close

## 4.6 Module Tab

The module panel allows you to discover available M8190A/M8121A modules and to define a multi-module group consisting of one master and up to five slave modules. The VISA resource strings for available M8190A/M8121A modules are displayed in a list under column “VISA Resource”. The drop-down list under column “Mode” provides options to specify whether a module will be part of multi-module group or not. Select either “Master” or “Slave” to add a module to the multi-module group. The option “None” indicates that the module is not part of the group. The module tab also allows you to switch between “Configuration” and “Operation” mode using the “Configuration Mode” check box.

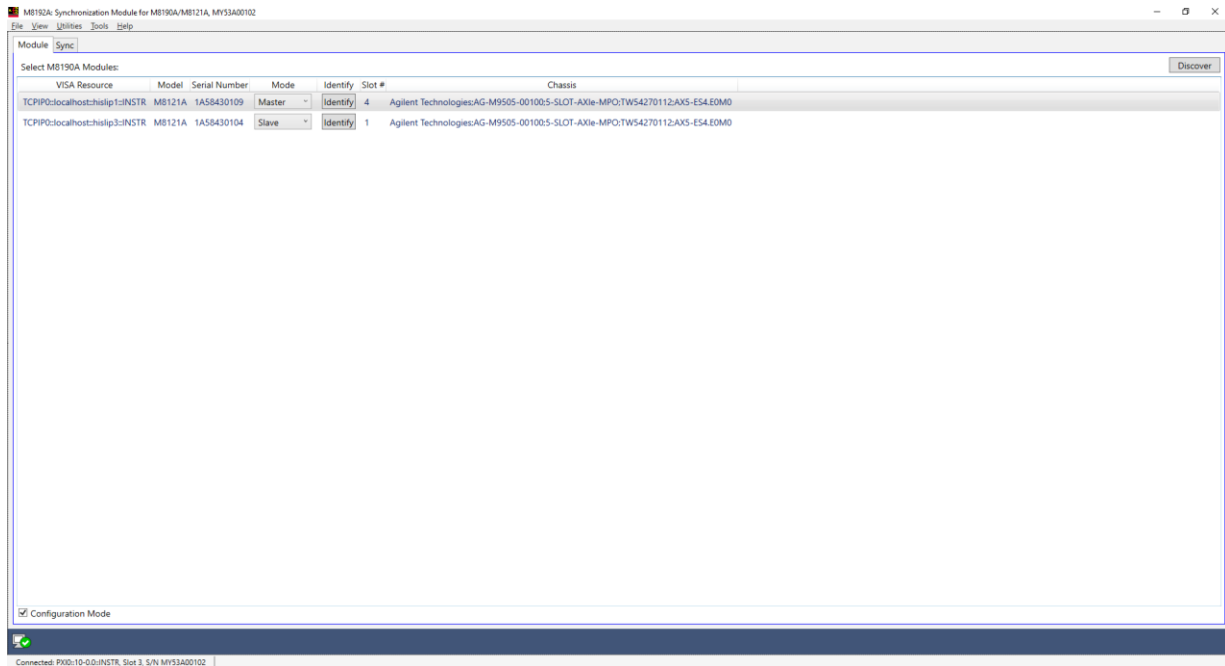

Figure 15 Module Tab

It has the following controls:

- Discover: Click this button to find the available M8190A/M8121A modules. The modules that are found are displayed in the list. The firmware of the modules to be discovered must be running and the modules must be entered into the Keysight Connection Expert.
- M8190A/M8121A Module Selection List: It has following columns:
  - VISA Resource: Displays the visa resource string of the M8190A/M8121A module.
  - Model: Displays the model number of the module.
  - Mode: The combo-box in this column can be used to set the multi-module mode of the module. Select either “Master” or “Slave” to add a module to synchronization group. The option “None” is used to indicate that the module is not part of the synchronization group.
  - Serial Number: Displays the serial number of M8190A/M8121A module.
  - Slot Number: Displays the slot number in AXIe chassis.
  - Chassis: Displays the AXIe chassis information.
  - Identify: The “Identify” button under this column is used to identify a module. On clicking this button, the access LED of the M8190A/M8121A module will be flashed for 10 seconds. This allows easy identification of module in a setup consisting of multiple AXI frames and multiple modules.
- Configuration Mode: This check box can be used to switch between “Configuration” and “Operation” mode. The check box is enabled only when “Master” module is selected as it is not possible to switch to “Operation” mode if no master is selected. Similarly, while in “Operation” mode if signal generation is started this check box is disabled. You need to stop the signal generation to switch to “Configuration” mode.

#### NOTE

It is recommended to follow the below order when exiting the application:

- Stop the system.
- Switch to Configuration Mode.
- Exit the M8192 Soft Front Panel.
- Exit any M8190A/M8121A Soft Front Panel if necessary.
- Exit the M8190A firmware instances if not required any more.

## 4.7 Sync Tab

The Sync tab allows you to modify parameters that affect all the modules in the synchronous system. This tab can be used to:

- Configure the M8192 trigger input
- Set trigger threshold and impedance
- Set the multi-module group in arm mode and send software trigger to start signal generation
- Stop signal generation and disable arm mode.

In addition, the Sync tab provides the graphical representation of:

- Sys Clk In and Sync Clk Out for master and slave modules
- Trigger In and Trigger Out for master and slave modules.

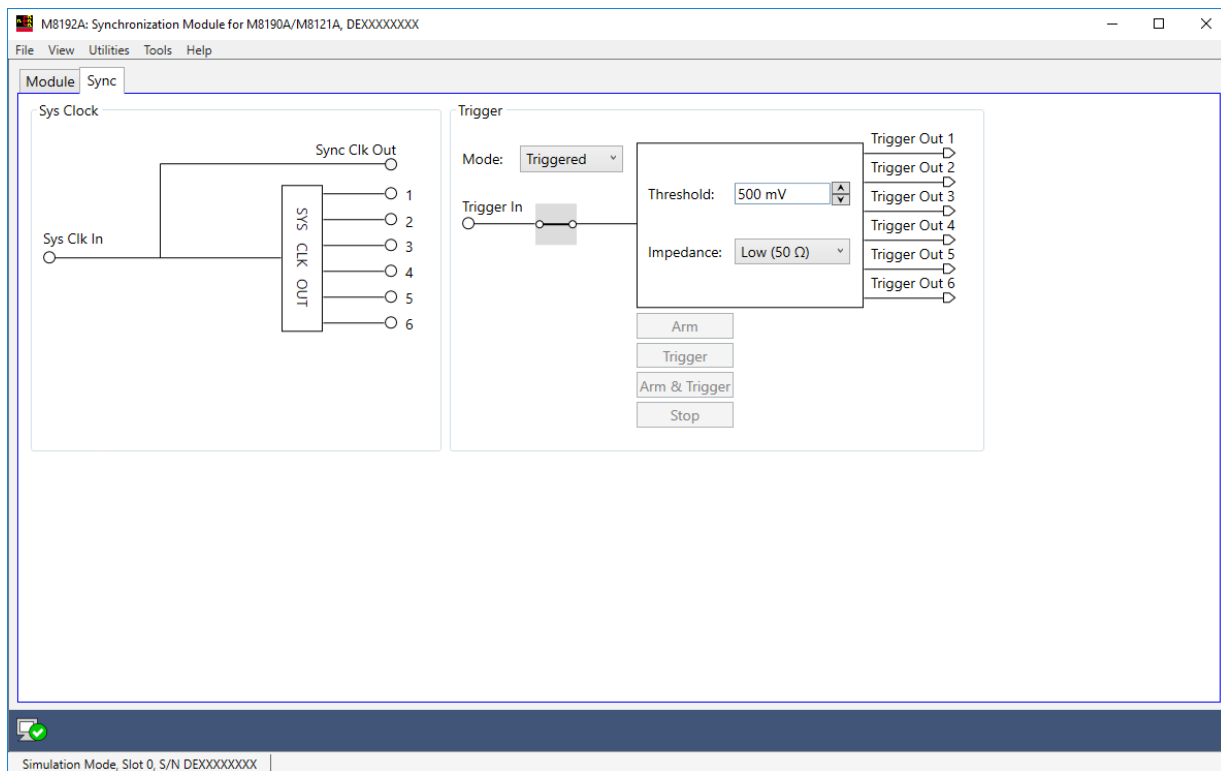

Figure 16 Sync Tab

The Sync Tab provides following controls:

- Sys Clk Out: Shows the Sys Clk Out connection to master and slave modules. While switching to "Operation" mode if there is no cabling issue and Sys Clk Out connections are valid, the output symbols corresponding to each module turn "Green". In case of cabling issues, the symbols turn "Red".
- Trigger In On/Off: Use this switch to enable/disable the trigger hardware input. When hardware input is disabled, trigger can only be generated using software trigger (see "Trigger" and "Arm & Trigger" button descriptions below).
- Trigger Out: Shows the Trigger Out connection to master and slave modules. While switching to "Operation" mode if there is no cabling issue and Trigger Out connections are valid, the output symbols corresponding to each module turn "Green". In case of cabling issues, the symbols turn "Red".
- Trigger mode  
Refer to the note described in the `:INITiate:CONTInous[:STATe][?]`  
`OFF|ON|0|1` command for setting the trigger mode.  
The following trigger modes are available:
  - Continuous – Signal generation starts after a trigger is received. The waveform or sequence is repeated endlessly.
  - Triggered – Signal generation is started by a trigger. After the waveform or sequence is played once, the next trigger starts the next iteration of the waveform or sequence.
- Threshold: Use the numeric control to enter the threshold level of the M8192A trigger input.
- Impedance: Use this dropdown list to set the impedance of the M8192A trigger input.
- Arm: Press this button to set all channels of the multi-module group to an armed state. Signal generation is started after a trigger is received.
- Trigger: Press this button to send software trigger to all channels of the multi-module group for synchronous start of waveform generation.
- Arm & Trigger: Press this button to set all channels of the multi-module group to an armed state and to send software trigger to all channels for synchronous start of waveform generation.
- Stop: Press this button to stop signal generation and arming mode on all channels of the multi-module group.

An example to create a triggered waveform is shown in the description of the `:INIT:IMM` command. For details, see `:INITiate:IMMEDIATE` command.

# 5 Remote Programming

- 5.1 Introduction / 56
- 5.2 SCPI Programming / 56
- 5.3 Programming Recommendations / 59
- 5.4 System Related Commands (SYSTEM Subsystem) / 60
- 5.5 Common Command List / 64
- 5.6 Status Model / 66
- 5.7 :ARM/TRIGger Subsystem / 74
- 5.8 INSTRument Subsystem / 77
- 5.9 MMEMory Subsystem / 80
- 5.10 TEST Subsystem / 85

## 5.1 Introduction

This chapter describes the SCPI commands that are used to program M8192A module.

## 5.2 SCPI Programming

The SCPI programming is supported by the following three LAN protocols:

- **VXI-11:** The Visa Resource String is e.g. "TCPIP0::localhost::inst0::INSTR".
- **HiSLIP:** this protocol is recommended. It offers the functionality of VXI-11 protocol with better performance that is near socket performance. Visa Resource Strings look like "TCPIP0::localhost::hislip0::INSTR". The correct resource string is shown in the M8192A Soft Front Panel's "About" dialog under "VISA Resource String for...". To use the HiSlip protocol an I/O library such as the Keysight I/O Libraries Suite must be installed. Since the protocol is new it might not be supported by the installed I/O library. The Keysight I/O Libraries Suite 16.1 and above supports it. However, the Keysight I/O Libraries Suite might be installed as secondary I/O library. In this case, check if the primary I/O library supports HiSLIP. If it does not, the socket protocol must be used.
- **Socket:** this protocol can be used with any I/O library or using standard operating system socket functionality connecting to port 5025. This protocol must be used if the used I/O library is not supporting HiSLIP protocol. Visa Resource string looks like "TCPIP0::localhost::5025::SOCKET", the exact resource string can be seen in the M8192A Soft Front Panel's "About" dialog under "VISA Resource String for...".

### NOTE

AgM8192 Firmware.exe must be started prior to sending SCPI to the instrument. (See [AgM8192SFP.exe](#))

---

### 5.2.1 AgM8192SFP.exe

The M8192A Software Front Panel and Firmware are one application. You need to start M8192 Soft Front Panel (AgM8192SFP.exe) before sending SCPI commands to the instrument. This can be done in the Windows *Start* menu (*Keysight* → *M8192* → *M8192 Soft Front Panel*). You can open the "About" dialog from the M8192A Soft Front Panel to see the VISA Resource String for the different connection types.



## 5.2.1.1 Command Line Arguments

(See [Communication](#) for details about /s, /t, /i, /AutoID, /NoAutoID, /FallBack).

**Table 8** Command Line Arguments

Option	Description
/Socket socketPort	Set the socket port at which the firmware waits for SCPI commands
/Telnet telnetPort	Set the telnet port at which the firmware waits for SCPI commands
/Inst instrumentNumber	Set the instrument number (instN, hislipN) at which the firmware waits for SCPI commands
/AutoID	Automatically select ports and number for the connections (default behavior).
/NoAutoID	Disable the default behavior; i.e. do not automatically select ports and number for the connections.
/FallBack	Try to find unused ports and number if starting a server fails.
/r resourceName	Visa PXI resource string of the module to connect to, e.g. PXI12::0::0::INSTR. If this is the last parameter on the command line, the "/r" can be omitted.
/Master masterModule	Set the M8190A/M8121A clock master module (LAN VISA resource string, i.e. SOCKET, INST, or HiSLIP).
/Slave slaveModule	Add an M8190A/M8121A clock slave module (LAN VISA resource string, i.e. SOCKET, INST, or HiSLIP)

## 5.2.1.2 Communication

Depending on the command line arguments /s, /t, /i, /AutoID, /NoAutoID, /FallBack, the firmware starts several servers to handle SCPI commands. (Refer to the table above.)

**/Socket, /Telnet, /Inst:** If -1, don't start the respective servers

- Defaults:
  - Socket port: 5025 (e.g. TCPIP0::localhost::5025::SOCKET)
  - Telnet port: 5024
  - HiSLIP, VXI-11.3: 0 (e.g. TCPIP0::localhost::hislip0::INSTR, TCPIP0::localhost::inst0::INSTR)

**/Fallback** : If starting a server fails because of a conflict, try using another port or number

- HiSLIP, VXI-11.3: increase the index until a server can be started successfully
- Socket, Telnet: start with the port 60000, then increase it until the servers can be started successfully. If neither socket nor telnet is disabled the firmware tries to start the servers on two consecutive ports
- (socket port = telnet port + 1)

**/AutoID** : Automatically select ports and number for the connections, which are unique per instrument.

- This is the default behavior; it is not necessary to specify this argument on the command line.
- If only one AXIe module is connected to this PC and it is an M8192 module, first try to use the command line arguments /Socket, /Telnet, /Inst or their respective default values if they are not specified. If starting the servers fails, proceed with the steps below.
- /Socket, /Telnet, /Inst are ignored (unless they are -1 and a server is disabled)
- If the firmware detects more than one AXIe module, use a special mechanism to obtain a number for the HiSLIP and VXI-11.3 servers, which makes sure that the firmware uses always the same VISA resource string per module
- The socket and telnet port are then calculated from the HiSLIP index:
  - telnet port = 60000 + 2 \* <HiSLIP index>
  - socket port = 60000 + 2 \* <HiSLIP index> + 1

**/NoAutoID** : Do not automatically select ports and number for the connections, use the values specified with /Socket, /Telnet, /Inst or their respective default values instead.

If both /NoAutoID and /AutoID are specified, /AutoID overrides /NoAutoID.

## 5.3 Programming Recommendations

This section lists some recommendations for programming the instrument.

Start programming from the default setting. The common command for setting the default setting is:

```
*RST
```

The SCPI standard defines a long and a short form of the commands. For fast programming speed, it is recommended to use the short forms. The short forms of the commands are represented by upper case letters. For example the short form of the command to start/begin event to all channels of the multi-module group is:

```
: TRIG: BEG
```

To improve programming speed it is also allowed to skip optional subsystem command parts. Optional subsystem command parts are depicted in square brackets, e.g. :TRIGger[:SEQuence][:START]:BEGin[:IMMEdiate]

If it is important to know whether the last command is completed then send the common query:

```
*OPC?
```

It is recommended to test the new setting which will be programmed on the instrument by setting it up manually. When you have found the correct setting, then use this to create the program.

In the program it is recommended to send the command for starting data generation (:INIT:IMM) as the last command. This way intermediate stop/restarts are avoided and optimum execution performance is achieved.

```
*RST           # set default settings
...           # other commands to set modes
...           # and parameters
:ARM:TRIG:IMP HIGH # set trigger impedance to High
:INIT:IMM      # start data generation.
```

## 5.4 System Related Commands (SYSTEM Subsystem)

### 5.4.1 :SYSTEM:ERRor[:NEXT]?

<b>Command</b>	:SYST:ERR?
<b>Long</b>	:SYSTEM:ERRor?
<b>Parameters</b>	None
<b>Parameter Suffix</b>	None
<b>Description</b>	<p>Read and clear one error from the instrument's error queue.</p> <p>A record of up to 30 command syntax or hardware errors can be stored in the error queue. Errors are retrieved in first-in-first-out (FIFO) order. The first error returned is the first error that was stored. Errors are cleared as you read them.</p> <p>If more than 30 errors have occurred, the last error stored in the queue (the most recent error) is replaced with "Queue overflow". No additional errors are stored until you remove errors from the queue.</p> <p>If no errors have occurred when you read the error queue, the instrument responds with 0, "No error".</p> <p>The error queue is cleared by the *CLS command, when the power is cycled, or when the firmware is re-started.</p> <p>The error queue is not cleared by a reset (*RST) command.</p> <p>The error messages have the following format (the error string may contain up to 255 characters):</p> <p>error number,"Description", e.g.</p> <p>-113,"Undefined header".</p>
<b>Example</b>	<p>Query</p> <p>:SYST:ERR?</p>

### 5.4.2 :SYSTEM:HELP:HEADers?

<b>Command</b>	:SYST:HELP:HEAD?
<b>Long</b>	:SYSTEM:HELP:HEADers?
<b>Parameters</b>	None
<b>Parameter Suffix</b>	None
<b>Description</b>	<p>The HEADers? query returns all SCPI commands and queries and IEEE 488.2 common commands and common queries implemented by the instrument. The response is a &lt;DEFINITE LENGTH ARBITRARY BLOCK RESPONSE DATA&gt; element. The full path for every command and query is returned separated by linefeeds. The syntax of the response is defined as: The &lt;nonzero digit&gt; and sequence of &lt;digit&gt; follow the rules in IEEE 488.2, Section 8.7.9. An &lt;SCPI header&gt; is defined as: It contains all the nodes from the root. The &lt;SCPI program mnemonic&gt; contains the node in standard SCPI format. The short form uses uppercase characters while the additional characters for the long form are in lowercase characters. Default nodes are surrounded by square brackets (□).</p>
<b>Example</b>	<p>Query</p> <p>:SYST:HELP:HEAD?</p>

### 5.4.3 :SYSTem:LICense:EXTended:LIST?

<b>Command</b>	:SYST:LIC:EXT:LIST?
<b>Long</b>	:SYSTem:LICense:EXTended:LIST?
<b>Parameters</b>	None
<b>Parameter Suffix</b>	None
<b>Description</b>	This query lists the licenses installed.
<b>Example</b>	Query :SYST:LIC:EXT:LIST?

### 5.4.4 :SYSTem:SET[?]

<b>Command</b>	:SYST:SET[?]
<b>Long</b>	:SYSTem:SET[?]
<b>Parameters</b>	<binary block data>
<b>Parameter Suffix</b>	None
<b>Description</b>	In query form, the command reads a block of data containing the instrument's complete set-up. The set-up information includes all parameter and mode settings, but does not include the contents of the instrument setting memories or the status group registers. The data is in a binary format, not ASCII, and cannot be edited. In set form, the block data must be a complete instrument set-up read using the query form of the command. This command has the same functionality as the *LRN command.
<b>Example</b>	Command :SYST:SET <binary block data>  Query :SYST:SET?

### 5.4.5 :SYSTem:VERSion?

<b>Command</b>	:SYST:VERS?
<b>Long</b>	:SYSTem:VERSion?
<b>Parameters</b>	None
<b>Parameter Suffix</b>	None
<b>Description</b>	This query returns a formatted numeric value corresponding to the SCPI version number for which the instrument complies, for example "1999.0".
<b>Example</b>	Query :SYST:VERS?

## 5.4.6 :SYSTem:COMMunicate:\*?

These queries return information about the instrument firmware's available connections. If a connection is not available the returned value is -1.

This is only useful if there is more than one Keysight module connected to a PC, otherwise one would normally use the default connections (HiSLIP and VXI-11 instrument number 0, socket port 5025, telnet port 5024)

One can never be sure if a socket port is already in use, so one could e.g. specify a HiSLIP number on the command line (`AgM8192Firmware.exe /AutoID /i 5 /Fallback /r ...`) and let the firmware find an unused socket port. Then this socket port can be queried using the HiSLIP connection.

### 5.4.6.1 :SYSTem:COMMunicate:INSTr[:NUMBer]?

<b>Command</b>	<code>:SYST:COMM:INST?</code>
<b>Long</b>	<code>:SYSTem:COMMunicate:INSTr?</code>
<b>Parameters</b>	None
<b>Parameter Suffix</b>	None
<b>Description</b>	This query returns the VXI-11 instrument number used by the firmware.
<b>Example</b>	Query <code>:SYST:COMM:INST?</code>

### 5.4.6.2 :SYSTem:COMMunicate:HISLip[:NUMBer]?

<b>Command</b>	<code>:SYST:COMM:HISL?</code>
<b>Long</b>	<code>:SYSTem:COMMunicate:HISLip?</code>
<b>Parameters</b>	None
<b>Parameter Suffix</b>	None
<b>Description</b>	This query returns the HiSLIP number used by the firmware.
<b>Example</b>	Query <code>:SYST:COMM:HISL?</code>

### 5.4.6.3 :SYSTem:COMMunicate:SOCKet[:PORT]?

<b>Command</b>	:SYST:COMM:SOCK?
<b>Long</b>	:SYSTem:COMMunicate:SOCKet?
<b>Parameters</b>	None
<b>Parameter Suffix</b>	None
<b>Description</b>	This query returns the socket port used by the firmware.
<b>Example</b>	Query :SYST:COMM:SOCK?

### 5.4.6.4 :SYSTem:COMMunicate:TELNet[:PORT]?

<b>Command</b>	:SYST:COMM:TELN?
<b>Long</b>	:SYSTem:COMMunicate:TELNet?
<b>Parameters</b>	None
<b>Parameter Suffix</b>	None
<b>Description</b>	This query returns the telnet port used by the firmware.
<b>Example</b>	Query :SYST:COMM:TELN?

## 5.5 Common Command List

### 5.5.1 \*IDN?

Read the instrument's identification string, which contains four fields separated by commas. The first field is the manufacturer's name, the second field is the model number, the third field is the serial number, and the fourth field is a revision code which contains four numbers separated dots and a fifth number separated by a dash:

Keysight Technologies, M8192A,<serial number>, x.x.x.x-h

x.x.x.x= Firmware revision number, e.g. 2.0.0.0

h= Hardware revision number

### 5.5.2 \*CLS

Clear the event register in all register groups. This command also clears the error queue and cancels a \*OPC operation. It doesn't clear the enable register.

### 5.5.3 \*ESE

Enable bits in the Standard Event Status Register to be reported in the Status Byte. The selected bits are summarized in the "Standard Event" bit (bit 5) of the Status Byte Register. The \*ESE? query returns a value which corresponds to the binary-weighted sum of all bits enabled decimal by the \*ESE command. These bits are not cleared by a \*CLS command. Value Range: 0–255.

### 5.5.4 \*ESR?

Query the Standard Event Status Register. Once a bit is set, it remains set until cleared by a \*CLS (clear status) command or queried by this command. A query of this register returns a decimal value which corresponds to the binary-weighted sum of all bits set in the register.

### 5.5.5 \*OPC

Set the "Operation Complete" bit (bit 0) in the Standard Event register after the previous commands have been completed.

### 5.5.6 \*OPC?

Return "1" to the output buffer after the previous commands have been completed. Other commands cannot be executed until this command completes.

### 5.5.7 \*OPT?

Read the installed options. The response consists of any number of fields separated by commas.



### 5.5.8 \*RST

Reset instrument to its factory default state.

### 5.5.9 \*SRE[?]

Enable bits in the Status Byte to generate a Service Request. To enable specific bits, you must write a decimal value which corresponds to the binary-weighted sum of the bits in the register. The selected bits are summarized in the “Master Summary” bit (bit 6) of the Status Byte Register. If any of the selected bits change from “0” to “1”, a Service Request signal is generated. The \*SRE? query returns a decimal value which corresponds to the binary-weighted sum of all bits enabled by the \*SRE command.

### 5.5.10 \*STB?

Query the summary (status byte condition) register in this register group. This command is similar to a Serial Poll but it is processed like any other instrument command. This command returns the same result as a Serial Poll but the “Master Summary” bit (bit 6) is not cleared by the \*STB? command.

### 5.5.11 \*TST?

Execute Self Tests. If self-tests pass, a 0 is returned. A number larger than 0 indicates the number of failed tests.

To get actual messages, use :TEST:TST?

### 5.5.12 \*LRN?

Query the instrument and return a binary block of data containing the current settings (learn string). You can then send the string back to the instrument to restore this state at a later time. For proper operation, do not modify the returned string before sending it to the instrument. Use :SYST:SET to send the learn string. See section [5.4.4](#).

### 5.5.13 \*WAI

Prevents the instrument from executing any further commands until the current command has finished executing.

## 5.6 Status Model

### Introduction

This section describes the structure of the SCPI status system used by the M8192A. The status system records various conditions and states of the instrument in several register groups as shown on the following pages. Each of the register groups is made up of several low level registers called Condition registers, Event registers, and Enable registers which control the action of specific bits within the register group.

These groups are explained below:

- A condition register continuously monitors the state of the instrument. The bits in the condition register are updated in real time and the bits are not latched or buffered. This is a read-only register and bits are not cleared when you read the register. A query of a condition register returns a decimal value which corresponds to the binary-weighted sum of all bits set in that register.
- An event register latches the various events from changes in the condition register. There is no buffering in this register; while an event bit is set, subsequent events corresponding to that bit are ignored. This is a read only register. Once a bit is set, it remains set until cleared by query command (such as `STAT:QUES:EVENT?`) or a `*CLS` (clear status) command. A query of this register returns a decimal value which corresponds to the binary-weighted sum of all bits set in that register.
- An enable register defines which bits in the event register will be reported to the Status Byte register group. You can write to or read from an enable register. A `*CLS` (clear status) command will not clear the enable register but it does clear all bits in the event register. A `STAT:PRES` command clears all bits in the enable register. To enable bits in the enable register to be reported to the Status Byte register, you must write a decimal value which corresponds to the binary weighted sum of the corresponding bits.
- Transition Filters are used to detect changes of the state in the condition register and set the corresponding bit in the event register. You can set transition filter bits to detect positive transitions (PTR), negative transitions (NTR) or both. Transition filters are read/write registers. They are not affected by `*CLS`.

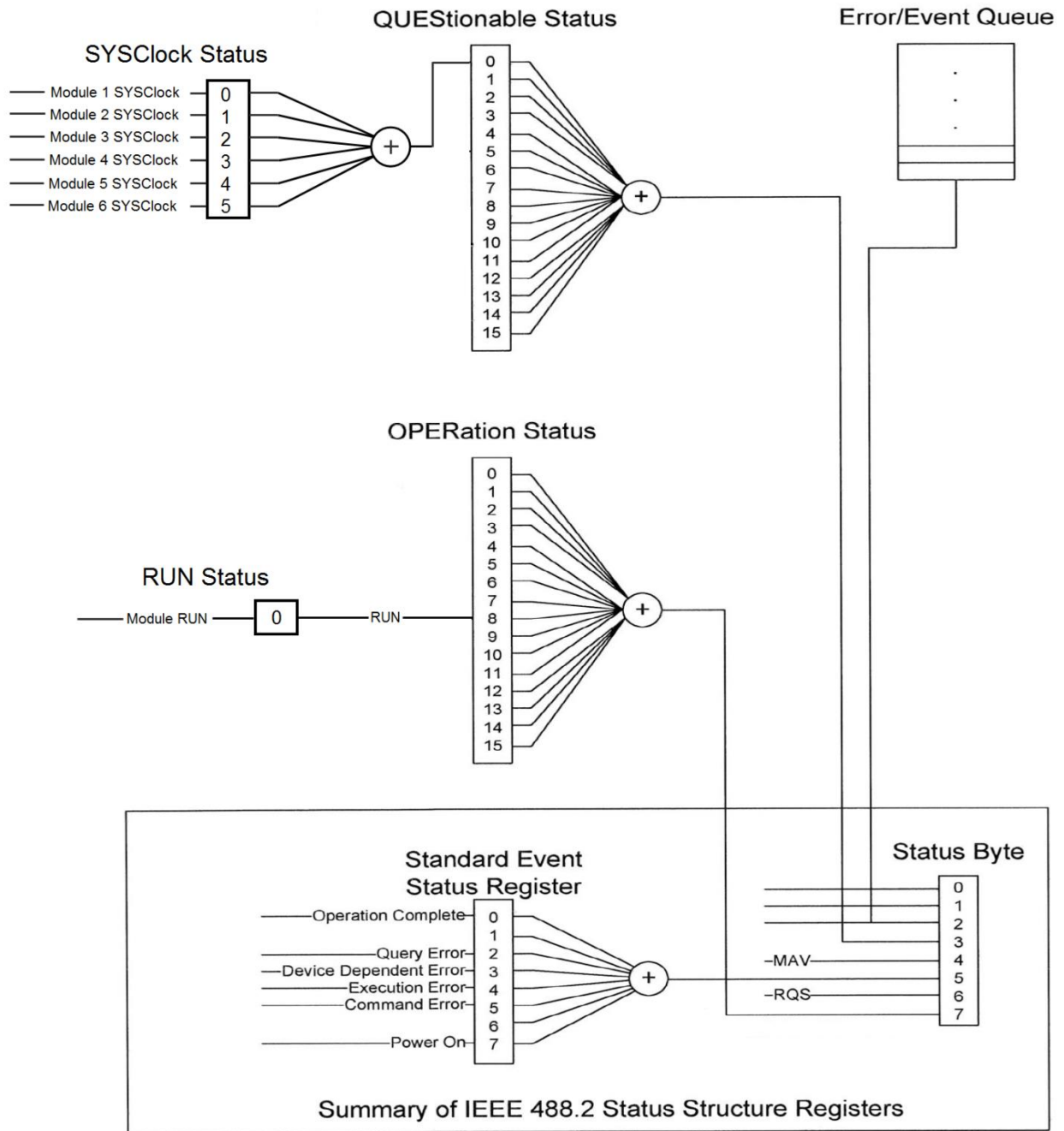

Figure 17 Status Register Structure

### 5.6.1 :STATus:PRESet

Clears all status group event registers. Presets the status group enables PTR and NTR registers as follows:

ENABLE = 0x0000, PTR = 0xffff, NTR = 0x0000

### 5.6.2 Status Byte Register

The Status Byte summary register reports conditions from the other status registers. Data that is waiting in the instrument's output buffer is immediately reported on the "Message Available" bit (bit 4) for example. Clearing an event register from one of the other register groups will clear the corresponding bits in the Status Byte condition register. Reading all messages from the output buffer, including any pending queries, will clear the "Message Available" bit. To set the enable register mask and generate an SRQ (service request), you must write a decimal value to the register using the \*SRE command.

**Table 9** Status Byte Register

Bit Number		Decimal Value	Definition
0	Not used	1	Not Used. Returns "0"
1	Not used	2	Not Used. Returns "0"
2	Error Queue	4	One or more errors are stored in the Error Queue
3	Questionable Data	8	One or more bits are set in the Questionable Data Register (bits must be enabled)
4	Message Available	16	Data is available in the instrument's output buffer
5	Standard Event	32	One or more bits are set in the Standard Event Register
6	Master Summary	64	One or more bits are set in the Status Byte Register
7	Operational Data	128	One or more bits set in the Operation Data Register (bits must be enabled)

### 5.6.3 Questionable Data Register Command Subsystem

The Questionable Data register group provides information about the quality or integrity of the instrument. Any or all of these conditions can be reported to the Questionable Data summary bit through the enable register.

**Table 10** Questionable Data Register

Bit Number		Decimal Value	Definition
0	SYSClock Status warning	1	One or multiple system clock outputs have been switched off (to protect themselves).
1	Not used	2	Returns "0"
2	Not used	4	Returns "0"
3	Not used	8	Returns "0"
4	Not used	16	Returns "0"
5	Not used	32	Returns "0"
6	Not used	64	Returns "0"
7	Not used	128	Returns "0"
8	Not used	256	Returns "0"
9	Not used	512	Returns "0"
10	Not used	1024	Returns "0"
11	Not used	2048	Returns "0"
12	Not used	4096	Returns "0"
13	Not used	8192	Returns "0"
14	Not used	16384	Returns "0"
15	Not used	32768	Returns "0"

The following commands access the questionable status group.

#### 5.6.3.1 :STATus:QUESTIONable[:EVENT]?

Reads the event register in the questionable status group. It's a read-only register. Once a bit is set, it remains set until cleared by this command or the \*CLS command. A query of the register returns a decimal value which corresponds to the binary-weighted sum of all bits set in the register.

#### 5.6.3.2 :STATus:QUESTIONable:CONDition?

Reads the condition register in the questionable status group. It's a read-only register and bits are not cleared when you read the register. A query of the register returns a decimal value which corresponds to the binary-weighted sum of all bits set in the register.

#### 5.6.3.3 :STATus:QUESTIONable:ENABle[?]

Sets or queries the enable register in the questionable status group. The selected bits are then reported to the Status Byte. A \*CLS will not clear the enable register but it does clear all bits in the event register. To enable bits in the enable register, you must write a decimal value which corresponds to the binary-weighted sum of the bits you wish to enable in the register.

#### 5.6.3.4 :STATus:QUESTIONable:NTRansition[?]

Sets or queries the negative-transition register in the questionable status group. A negative transition filter allows an event to be reported when a condition changes from true to false. Setting both positive/negative filters true allows an event to be reported anytime the condition changes. Clearing both filters disable event reporting. The contents of transition filters are unchanged by \*CLS and \*RST.

### 5.6.3.5 :STATus:QUEStionable:PTRansition[?]

Set or queries the positive-transition register in the questionable status group. A positive transition filter allows an event to be reported when a condition changes from false to true. Setting both positive/negative filters true allows an event to be reported anytime the condition changes. Clearing both filters disable event reporting. The contents of transition filters are unchanged by \*CLS and \*RST.

## 5.6.4 Operation Status Subsystem

The Operation Status register contains conditions which are part of the instrument's normal operation.

**Table 11** Operation Status Register

Bit Number		Decimal Value	Definition
0	Not used	1	Returns "0"
1	Not used	2	Returns "0"
2	Not used	4	Returns "0"
3	Not used	8	Returns "0"
4	Not used	16	Returns "0"
5	Not used	32	Returns "0"
6	Not used	64	Returns "0"
7	Not used	128	Returns "0"
8	Run Status	256	Indicates if the multi-module group is in running/armed state (:INIT:IMM was executed).
9	Not used	512	Returns "0"
10	Not used	1024	Returns "0"
11	Not used	2048	Returns "0"
12	Not used	4096	Returns "0"
13	Not used	8192	Returns "0"
14	Not used	16384	Returns "0"
15	Not used	32768	Returns "0"

The following commands access the operation status group.

### 5.6.4.1 :STATus:OPERation[:EVENT]?

Reads the event register in the operation status group. It's a read-only register. Once a bit is set, it remains set until cleared by this command or \*CLS command. A query of the register returns a decimal value which corresponds to the binary-weighted sum of all bits set in the register.

#### 5.6.4.2 :STATus:OPERation:CONDition?

Reads the condition register in the operation status group. It's a read-only register and bits are not cleared when you read the register. A query of the register returns a decimal value which corresponds to the binary-weighted sum of all bits set in the register.

#### 5.6.4.3 :STATus:OPERation:ENABLE[?]

Sets or queries the enable register in the operation status group. The selected bits are then reported to the Status Byte. A \*CLS will not clear the enable register but it does clear all bits in the event register. To enable bits in the enable register, you must write a decimal value which corresponds to the binary-weighted sum of the bits you wish to enable in the register.

#### 5.6.4.4 :STATus:OPERation:NTRansition[?]

Sets or queries the negative-transition register in the operation status group. A negative transition filter allows an event to be reported when a condition changes from true to false. Setting both positive/negative filters true allows an event to be reported anytime the condition changes. Clearing both filters disable event reporting. The contents of transition filters are unchanged by \*CLS and \*RST.



### 5.6.4.5 :STATus:OPERation:PTRansition[?]

Set or queries the positive-transition register in the operation status group. A positive transition filter allows an event to be reported when a condition changes from false to true. Setting both positive/negative filters true allows an event to be reported anytime the condition changes. Clearing both filters disable event reporting. The contents of transition filters are unchanged by \*CLS and \*RST.

## 5.6.5 Run Status Subsystem

The Run Status register contains the run status conditions of the multi-module group.

The following SCPI commands and queries are supported:

```
:STATus:OPERation:RUN[:EVENT]?
:STATus:OPERation:RUN:CONDition?
:STATus:OPERation:RUN:ENABle[?]
:STATus:OPERation:RUN:NTRansition[?]
:STATus:OPERation:RUN:PTRansition[?]
```

**Table 12** Run Status Register

Bit Number	Decimal Value	Definition
0 Run Status	1	Indicates if the multi-module group is in running/armed state (:INIT:IMM was executed).

## 5.7 :ARM/TRIGger Subsystem

### 5.7.1 :ABORt

Command	:ABOR
Long	:ABORt
Parameters	None
Parameter Suffix	None
Description	Stop signal generation on all channels of the multi-module group.
Example	Command :ABOR

### 5.7.2 :INITiate:CONTInous[:STATe][?] OFF|ON|0|1

#### NOTE

Normally triggers are sent by the M8192A to the M8190A/M8121A modules as rising edges. It can happen that the trigger to start signal generation is already sent to the M8190A/M8121A modules by the M8192A, when there is high a level signal present on the trigger input of the M8192A. The M8192A trigger input is routed through two synchronization flip-flops, then passed on to the M8190A/M8121A. The flip-flops are held in reset while the M8190A/M8121A modules are set up and armed. This is necessary because the process of arming the M8190A/M8121A modules happens sequentially and it must be guaranteed that during that time no trigger pulses are forwarded to the M8190A/M8121A modules. As soon as all of the M8190A/M8121A modules are ready, the reset on the synchronization flip flops is released. If there is a high-level signal present on the trigger input at that time, it will cause an immediate trigger edge for the M8190A/M8121A modules.

If this behavior is not acceptable it is recommended to use some external “gating” circuitry that disables the trigger signal until the system has been started and then enables the trigger signal.

---

Command	:INIT:CONT[:STAT][?]
Long	:INITiate:CONTInous[:STATe][?]
Parameters	OFF ON 0 1
Parameter Suffix	None
Description	Set or query the continuous mode. <ul style="list-style-type: none"> <li>• 0/OFF – Continuous mode is off, that is the mode is “triggered”. Signal generation is started by a trigger. After the waveform or sequence is played once, the next trigger starts the next iteration of the waveform or sequence.</li> <li>• 1/ON – Continuous mode is on. Signal generation is started by a trigger. The waveform or sequence is repeated endlessly</li> </ul>

<b>Example</b>	Command :INIT:CONT:STAT ON
	Query :INIT:CONT:STAT?

### 5.7.3 :INITiate:IMMediate

<b>Command</b>	:INIT:IMM
<b>Long</b>	:INITiate:IMMediate
<b>Parameters</b>	None
<b>Parameter Suffix</b>	None
<b>Description</b>	Set all channels of the multi-module group to an armed state. Signal generation is started after a trigger is received.
<b>Example</b>	The following commands create a triggered waveform. // Create a synchronous system using the multi-module configuration commands // from the INSTRUMENT Subsystem. // Load waveforms into all channels of the M8190A/M8121A modules. // Set triggered mode. :INIT:CONT 0 // Leave configuration mode and enter operation mode. :INST:MMOD:CONF 0 // Set the advancement modes on all M8190A/M8121A channels to "Auto". // Start signal generation. :INIT:IMM // On every software trigger the waveform is generated once. :TRIG:BEG

### 5.7.4 :ARM[:SEQuence][:STARt][:LAYer]:TRIGger:LEVel[?] <level>|MINimum|MAXimum

<b>Command</b>	:ARM[:SEQ] [:STAR] [:LAY] :TRIG:LEV[?]
<b>Long</b>	:ARM[:SEQuence] [:STARt] [:LAYer] :TRIGger:LEVel[?]
<b>Parameters</b>	<level> MINimum MAXimum
<b>Parameter Suffix</b>	Volt (V) or millivolt (mV)
<b>Description</b>	Set or query the threshold level of the M8192A trigger input. <level> – Threshold level voltage.
<b>Example</b>	Command :ARM:TRIG:LEV 3e-9  Query :ARM:TRIG:LEV?

### 5.7.5 :ARM[:SEQuence][:STARt][:LAYer]:TRIGger:IMPedance[?] LOW|HIGH

<b>Command</b>	:ARM[:SEQ][[:STAR][[:LAY]:TRIG:IMP[?]
<b>Long</b>	:ARM[:SEQuence][[:STARt][[:LAYer]:TRIGger:IMPedance[?]
<b>Parameters</b>	LOW HIGH
<b>Parameter Suffix</b>	None
<b>Description</b>	Set or query the impedance of the M8192A trigger input. LOW – low impedance (50 $\Omega$ ) HIGH – high impedance (1 k $\Omega$ )
<b>Example</b>	Command :ARM:TRIG:IMP HIGH  Query :ARM:TRIG:IMP?

### 5.7.6 :TRIGger[:SEQuence][:STARt]:BEGin[:IMMediate]

<b>Command</b>	:TRIG[:SEQ][[:STAR]:BEG[:IMM]
<b>Long</b>	:TRIGger[:SEQuence][[:STARt]:BEGin[:IMMediate]
<b>Parameters</b>	None
<b>Parameter Suffix</b>	None
<b>Description</b>	Send the start/begin event to all channels of the multi-module group.
<b>Example</b>	Command :TRIG:BEG

### 5.7.7 :TRIGger[:SEQuence][:STARt]:BEGin:HWDisable[:STATe][?] 0|1|OFF|ON

<b>Command</b>	:TRIG[:SEQ][[:STAR]:BEG:HWD[:STAT][?]
<b>Long</b>	:TRIGger[:SEQuence][[:STARt]:BEGin:HWDisable[:STATe][?]
<b>Parameters</b>	0 1 OFF ON
<b>Parameter Suffix</b>	None
<b>Description</b>	Set or query the M8192A's hardware input disable state for the trigger function. When the hardware input is disabled, a trigger can only be generated using the :TRIGger[:SEQuence][:STARt]:BEGin[:IMMediate] command. When the hardware input is enabled, a trigger can be generated by command or by a signal present at the trigger input of the M8192A.
<b>Example</b>	Command :TRIG:BEG:HWD ON  Query :TRIG:BEG:HWD?

## 5.8 INSTRUMENT Subsystem

### 5.8.1 :INSTRUMENT:SLOT[:NUMBER]?

<b>Command</b>	:INST:SLOT[:NUMB]?
<b>Long</b>	:INSTRUMENT:SLOT[:NUMBER]?
<b>Parameters</b>	None
<b>Parameter Suffix</b>	None
<b>Description</b>	Query the instrument's slot number in its AXIe frame.
<b>Example</b>	Query :INST:SLOT?

## 5.8.2 Multi-module configuration commands

These commands and queries are used to identify reachable M8190A/M8121A modules and to define a multi-module group consisting of one master module and up to five slave modules.

### 5.8.2.1 :INSTrument:MDIScover?

<b>Command</b>	:INST:MDIS?
<b>Long</b>	:INSTrument:MDIScover?
<b>Parameters</b>	None
<b>Parameter Suffix</b>	None
<b>Description</b>	This query returns a comma-separated list of VISA resource strings of all M8190A/M8121A modules known by the VISA Resource Manager.
<b>Example</b>	Query :INST:MDIS?

### 5.8.2.2 :INSTrument:IDENTify <visa\_resource\_string>

<b>Command</b>	:INST:IDEN
<b>Long</b>	:INSTrument:IDENTify
<b>Parameters</b>	<visa_resource_string>
<b>Parameter Suffix</b>	None
<b>Description</b>	This command toggles the green "Access" LED of the M8190A/M8121A module with the passed VISA resource string for 10 seconds. This allows easy identification of one module in a setup consisting of multiple AXI frames and multiple modules.
<b>Example</b>	Command :INST:IDEN "TCPIP0::localhost::hislip0::INSTR"

### 5.8.2.3 :INSTrument:SLAVe:LIST?

<b>Command</b>	:INST:SLAV:LIST?
<b>Long</b>	:INSTrument:SLAVe:LIST?
<b>Parameters</b>	None
<b>Parameter Suffix</b>	None
<b>Description</b>	This query returns a comma-separated list of VISA resource strings of all M8190A/M8121A slave modules that belong to the multi-module group.
<b>Example</b>	Query :INST:SLAV:LIST?

#### 5.8.2.4 :INSTrument:MMODule:CONFIg[?] 0|1|OFF|ON

<b>Command</b>	:INST:MMOD:CONF[?]
<b>Long</b>	:INSTrument:MMODule:CONFIg[?]
<b>Parameters</b>	0 1 OFF ON
<b>Parameter Suffix</b>	None
<b>Description</b>	<p>The command form enables (1 ON) or disables (0 OFF) the multi-module configuration mode for the complete multi-module group. The command forms of the following SCPIs for master and slave selection are only available in multi-module configuration mode. When the multi-module configuration mode is disabled, the modifications become active.</p> <p>Furthermore, the commands for setting the clocking parameters on the M8190A/M8121A master module (DAC output mode, internal sample frequency, external sample frequency, sample clock source, reference clock source, and reference frequency) are only available in multi-module configuration mode.</p> <p>The query form returns the state of the multi-module configuration mode.</p>
<b>Example</b>	<p>Command</p> <pre>:INST:MMOD:CONF ON</pre> <p>Query</p> <pre>:INST:MMOD:CONF?</pre>

#### 5.8.2.5 :INSTrument:SLAVe:ADD < visa\_resource\_string >

<b>Command</b>	:INST:SLAV:ADD
<b>Long</b>	:INSTrument:SLAVe:ADD
<b>Parameters</b>	< visa_resource_string >
<b>Parameter Suffix</b>	None
<b>Description</b>	This command adds the M8190A/M8121A module with the passed VISA resource string as slave to the multi-module group.
<b>Example</b>	<p>Command</p> <pre>:INST:SLAV:ADD "TCPIP0::localhost::hislip0::INSTR"</pre>

#### 5.8.2.6 :INSTrument:SLAVe:DELeTe < visa\_resource\_string >

<b>Command</b>	:INST:SLAV:DEL
<b>Long</b>	:INSTrument:SLAVe:DELeTe
<b>Parameters</b>	< visa_resource_string >
<b>Parameter Suffix</b>	None
<b>Description</b>	This command deletes the M8190A/M8121A slave module with the passed VISA resource string from the multi-module group.
<b>Example</b>	<p>Command</p> <pre>:INST:SLAV:DEL "TCPIP0::localhost::hislip0::INSTR"</pre>

### 5.8.2.7 :INSTrument:SLAVe:DELeTe:ALL

Command	:INST:SLAV:DEL:ALL
Long	:INSTrument:SLAVe:DELeTe:ALL
Parameters	None
Parameter Suffix	None
Description	This command deletes all M8190A/M8121A slave modules from the multi-module group.
Example	Command :INST:SLAV:DEL:ALL

### 5.8.2.8 :INSTrument:MASTer[?][<visa\_resource\_string>]

Command	:INST:MAST[?]
Long	:INSTrument:MASTer[?]
Parameters	<visa_resource_string>
Parameter Suffix	None
Description	The command form selects the M8190A/M8121A module with the passed VISA resource string as master. The query form returns the VISA resource string of the M8190A/M8121A module that is the master or an empty string, if no master is selected.
Example	Command :INST:MAST "TCPIP0::localhost::hislip0::INSTR"  Query :INST:MAST?

## 5.9 MMEMory Subsystem

### NOTE

MMEM commands requiring <directory\_name> assume the current directory if a relative path or no path is provided. If an absolute path is provided, then it is ignored.

---

### 5.9.1 :MMEMory:CATalog? [<directory\_name>]

Command	:MMEM:CAT?
Long	:MMEMory:CATalog?
Parameters	None
Parameter Suffix	None



<b>Description</b>	<p>Query disk usage information (drive capacity, free space available) and obtain a list of files and directories in a specified directory in the following format:</p> <pre>&lt;numeric_value&gt;,&lt;numeric_value&gt;,{&lt;file_entry&gt;}</pre> <p>This command returns two numeric parameters and as many strings as there are files and directories. The first parameter indicates the total amount of storage currently used in bytes. The second parameter indicates the total amount of storage available, also in bytes. The &lt;file_entry&gt; is a string. Each &lt;file_entry&gt; indicates the name, type, and size of one file in the directory list:</p> <pre>&lt;file_name&gt;,&lt;file_type&gt;,&lt;file_size&gt;</pre> <p>As the Windows file system has an extension that indicates file type, &lt;file_type&gt; is always empty. &lt;file_size&gt; provides the size of the file in bytes. In case of directories, &lt;file_entry&gt; is surrounded by square brackets and both &lt;file_type&gt; and &lt;file_size&gt; are empty.</p>
<b>Example</b>	<pre>Query :MMEM:CAT?</pre>

### 5.9.2 :MMEMory:CDIRectory [<directory\_name>]

<b>Command</b>	:MMEM:CDIR
<b>Long</b>	:MMEMory:CDIRectory
<b>Parameters</b>	None
<b>Parameter Suffix</b>	None
<b>Description</b>	<p>Changes the default directory for a mass memory file system. The &lt;directory_name&gt; parameter is a string. If no parameter is specified, the directory is set to the *RST value. At *RST, this value is set to the default user data storage area, that is defined as System.Environment.SpecialFolder.Personal e.g. C:\Users\Name\Documents</p> <p>MMEMory:CDIRectory? – Query returns full path of the default directory.</p>
<b>Example</b>	<pre>Command :MMEM:CDIR "C:\Users\Name\Documents"</pre> <pre>Query :MMEM:CDIR?</pre>

### 5.9.3 :MMEMory:COPY <string>,<string>[,<string>,<string>]

<b>Command</b>	:MMEM:COPY
<b>Long</b>	:MMEMory:COPY
<b>Parameters</b>	<string>,<string>
<b>Parameter Suffix</b>	None

<b>Description</b>	<p>Copies an existing file to a new file or an existing directory to a new directory. Two forms of parameters are allowed. The first form has two parameters. In this form, the first parameter specifies the source, and the second parameter specifies the destination.</p> <p>The second form has four parameters. In this form, the first and third parameters specify the file names. The second and fourth parameters specify the directories. The first pair of parameters specifies the source. The second pair specifies the destination. An error is generated if the source doesn't exist or the destination file already exists.</p>
<b>Example</b>	<p>Command</p> <pre>:MMEM:COPY "C:\data.txt", "C:\data_new.txt"</pre>

#### 5.9.4 :MMEMory:DELeTe <file\_name>[,<directory\_name>]

<b>Command</b>	:MMEM:DEL
<b>Long</b>	:MMEMory:DELeTe
<b>Parameters</b>	<file_name>
<b>Parameter Suffix</b>	None
<b>Description</b>	Removes a file from the specified directory. The <file_name> parameter specifies the file to be removed.
<b>Example</b>	<p>Command</p> <pre>:MMEM:DEL "C:\data.txt"</pre>

#### 5.9.5 :MMEMory:DATA <file\_name>, <data>

<b>Command</b>	:MMEM:DATA
<b>Long</b>	:MMEMory:DATA
<b>Parameters</b>	<file_name>, <data>
<b>Parameter Suffix</b>	None
<b>Description</b>	The command form is MMEMory:DATA <file_name>,<data>. It loads <data> into the file <file_name>. <data> is in 488.2 block format. <file_name> is string data.
<b>Example</b>	<p>Command</p> <pre>:MMEM:DATA "C:\data.txt", #14test</pre>

#### 5.9.6 :MMEMory:DATA? <file\_name>

<b>Command</b>	:MMEM:DATA?
<b>Long</b>	:MMEMory:DATA?
<b>Parameters</b>	<file_name>
<b>Parameter Suffix</b>	None
<b>Description</b>	The query form is MMEMory:DATA? <file_name> with the response being the associated <data> in block format.
<b>Example</b>	<p>Query</p> <pre>:MMEM:DATA? "C:\data.txt"</pre>

### 5.9.7 :MMEMory:MDIRectory <directory\_name>

<b>Command</b>	:MMEM:MDIR
<b>Long</b>	:MMEMory:MDIRectory
<b>Parameters</b>	<directory_name>
<b>Parameter Suffix</b>	None
<b>Description</b>	Creates a new directory. The <directory_name> parameter specifies the name to be created.
<b>Example</b>	Command :MMEM:MDIR "C:\data_dir"

### 5.9.8 :MMEMory:MOVE <string>,<string>[,<string>,<string>]

<b>Command</b>	:MMEM:MOVE
<b>Long</b>	:MMEMory:MOVE
<b>Parameters</b>	<string>,<string>[,<string>,<string>]
<b>Parameter Suffix</b>	None
<b>Description</b>	Moves an existing file to a new file or an existing directory to a new directory. Two forms of parameters are allowed. The first form has two parameters. In this form, the first parameter specifies the source, and the second parameter specifies the destination.  The second form has four parameters. In this form, the first and third parameters specify the file names. The second and fourth parameters specify the directories. The first pair of parameters specifies the source. The second pair specifies the destination. An error is generated if the source doesn't exist or the destination file already exists.
<b>Example</b>	Command :MMEM:MDIR "C:\data_dir","C:\newdata_dir"

### 5.9.9 :MMEMory:RDIRectory <directory\_name>

<b>Command</b>	:MMEM:RDIR
<b>Long</b>	:MMEMory:RDIRectory
<b>Parameters</b>	<directory_name >
<b>Parameter Suffix</b>	None
<b>Description</b>	Removes a directory. The <directory_name> parameter specifies the directory name to be removed. All files and directories under the specified directory are also removed.
<b>Example</b>	Command :MMEM:RDIR "C:\newdata_dir"

### 5.9.10 :MMEMory:LOAD:CState <file\_name>

<b>Command</b>	:MMEM:LOAD:CST
<b>Long</b>	:MMEMory:LOAD:CState
<b>Parameters</b>	<file_name >
<b>Parameter Suffix</b>	None
<b>Description</b>	Current STate of instrument is loaded from a file.
<b>Example</b>	Command :MMEM:LOAD:CST "C:\data.txt"

### 5.9.11 :MMEMory:STORE:CState <file\_name>

<b>Command</b>	:MMEM:STOR:CST
<b>Long</b>	:MMEMory:STORE:CState
<b>Parameters</b>	<file_name >
<b>Parameter Suffix</b>	None
<b>Description</b>	Current STate of instrument is stored to a file.
<b>Example</b>	Command :MMEM:STOR:CST "C:\data.txt"

## 5.10 TEST Subsystem

### 5.10.1 :TEST:PON?

Command	:TEST:PON?
Long	:TEST:PON?
Parameters	None
Parameter Suffix	None
Description	Return the results of the power on self-tests.
Example	Query :TEST:PON?

### 5.10.2 :TEST:TST?

Command	:TEST:TST?
Long	:TEST:TST?
Parameters	None
Parameter Suffix	None
Description	Same as *TST?, but the actual test messages are returned.
Example	Query :TEST:TST?

#### NOTE

Currently same as :TEST:PON?

---



# 6 Characteristics

6.1 Performance Specification / 88

6.2 General / 88

6.3 Maintenance / 89

## 6.1 Performance Specification

The performance specification can be found in the data sheet available at:

<http://www.Keysight.com/find/M8192A>

## 6.2 General

**Table 13**      **Characteristics**

Characteristics	Description
Power consumption	60 W
Operating temperature	0 °C to 40 °C
Storage temperature	-40 °C to 70 °C
Operating humidity	5 % to 80 % relative humidity
Operating altitude	up to 2000 m
Safety designed to	IEC61010-1, UL61010, CSA22.2 61010.1 tested
Interface to controlling PC	PCIe (see AXIe chassis specification)
Form factor	1-slot AXIe module
Dimensions (W x H x D)	351 mm x 29 mm x 310 mm
Weight	3.1 kg
Warm-up time	30 minutes
Calibration interval	2 years recommended
Cooling Requirements	When operating the M8192A, choose a location that provides at least 80 mm of clearance at rear, and at least 30 mm of clearance at each side for the AXIe chassis.

### WARNING

The instrument is not designed for outdoor use. Do not expose the instrument to rain or other excessive moisture. Protect the instrument from humidity and temperature changes, which could cause condensation within the instrument.

Do not operate the instrument in the presence of flammable gases, fumes or powders. Operation of any electrical instrument in such an environment constitutes a definite safety hazard.



## 6.3 Maintenance

### 6.3.1 ESD Protection



#### CAUTION

All the connectors are very sensitive to electrostatic discharge (ESD). When you connect a device or cable that is not fully discharged to these connectors, you risk damage to the instrument and expensive instrument repairs.

---

#### CAUTION

Electrostatic discharge (ESD) can damage the circuits of the M8192A. Avoid applying static discharges to the front-panel connectors. Before connecting any coaxial cable to the connectors, momentarily short the center and outer conductors of the cable together. Avoid touching the front-panel connectors without first touching the frame of the instrument. Be sure the instrument and all connected devices (DUT, etc.) are properly earth-grounded (to a common ground) to prevent buildup of static charge and electrical over-stress.

---

## 6.3.2 Power and Ventilation Requirements

For power and ventilation requirements, refer to:

- <http://www.Keysight.com/find/M9505A> for 5-slot chassis related documentation.
- <http://www.Keysight.com/find/M9502A> for 2-slot chassis related documentation.

## 6.3.3 Thermal Protection

**Overheating Detection** The instrument monitors its internal temperature. If the temperature exceeds approximately 80 °C the power supply is switched off. The instrument will not turn on automatically if the temperature is decreasing again.

**Fan Failure** If a fan is broken or prevented from operating by a blockage the temperature will increase. When the temperature exceeds approximately 80 °C the overheating detection switches off the instrument for safety reasons. For reliability it is recommended to send instruments with broken or defective fans immediately to Keysight Service for repair.

## 6.3.4 Cleaning Recommendation

**WARNING**

To prevent electrical shock, disconnect the instrument from mains before cleaning. Use a dry cloth or one slightly dampened with water to clean external case parts. Do not attempt to clean internally.

---





This information is subject to change without notice.  
© Keysight Technologies 2022  
Edition 9.0, February 2022



M8192-91020

[www.keysight.com](http://www.keysight.com)