

# E8740A Automotive Radar Signal Analysis and Generation Solution

The Keysight E8740A automotive radar signal analysis and generation solution analyzes and generates automotive radar signals across the full frequency range for 24 GHz, 77 GHz and 79 GHz radar and provides scalable analysis bandwidth from 2.5 GHz to > 5 GHz, depending on test requirements.



## Table of Contents

Next-generation Automotive Radar Test Challenges .....	3
Keysight Automotive Radar Signal Analysis and Generation Solution .....	3
Radar Signal Analysis Solution Configurations .....	4
Signal generation solutions .....	5
E8740A-010 Radar RF Signal Analysis .....	6
E8740A-020 Basic Radar Signal Analysis .....	7
E8740A-030 Basic Plus Radar Signal Analysis .....	8
E8740A-040 Advanced Radar Signal Analysis .....	9
E8740A-050 Advanced Plus Radar Signal Analysis .....	10
E8740A-060 Performance Radar Signal Analysis .....	11
E8740A-070 Performance Radar Signal Generation .....	12
E8740A-080 Interference Test Solution .....	13
E8740A-090 Conformance Spurious Emission Test Solution .....	14
Hardware – Instruments .....	15
Software .....	18
FMCW Radar Analysis .....	21
Hardware Bundles .....	22
Definitions and acronyms .....	23

## Next-generation Automotive Radar Test Challenges

Automotive Radar has become a standard feature of mid-class cars and the radar technology continues to evolve, with higher frequencies, wider bandwidths, better resolution, and multiple targets. It can be a challenge to stay current with the advancing technologies, evolving standards, and emerging test requirements related to automotive radar systems.

There are many challenges during the test setup when working with mmWave frequencies such as 79 GHz radar. You need to consider the test setup, ultra-wideband mmWave measurements, signal-to-noise (SNR) loss as well as emerging standard requirements per region for interference testing. Not accounting for these requirements will impact the quality and performance of your radar module, potentially leading to expensive redesign, lengthened design cycles, and even possible product recalls.

## Keysight Automotive Radar Signal Analysis and Generation Solution

The Keysight E8740A automotive radar signal analysis and generation solution analyzes and generates automotive radar signals across the full frequency range for 24 GHz, 77 GHz and 79 GHz radar. It provides scalable analysis bandwidths, from 2.5 GHz to > 5 GHz, depending on your test requirement.

Our software application provides immediate access to accelerate your radar module testing. The Keysight KS83200A automation platform for automotive radar is a suite of standards-compliant routines for testing and validation of radar transmitters and receivers. Its automated routines simplify programming, customization and testing, and timely updates keep it current with the latest standards. The Keysight 89600 VSA software adds the capability of frequency modulated continuous wave (FMCW) radar analysis while Keysight N6708 Signal Studio enables custom waveform creation. In addition, you can expand your test capabilities by integrating the Keysight SystemVue automotive radar library software for simulation of multi-target detection and automotive radar 3D scan.

Within our overall solution there are two solution configurations for signal generation, and six solution configurations for analyzing automotive radar signals, depending on test requirements and budget.

The following pages outline each of the configurations, specifications associated with each as well as additional information.

# Automotive Radar Signal Analysis Solution Configurations

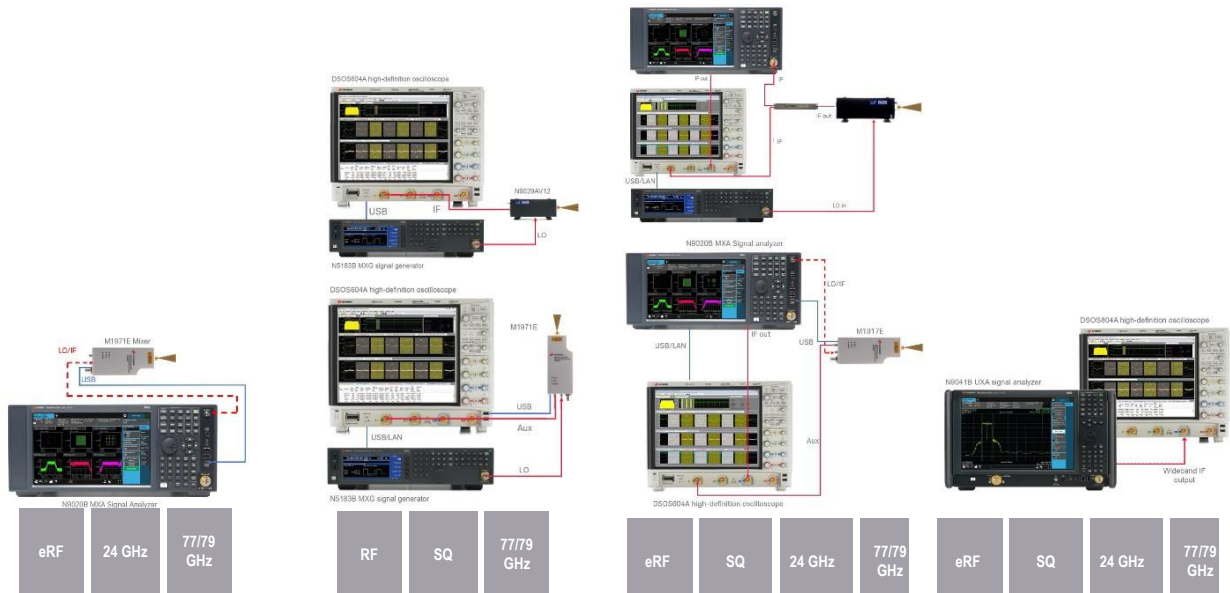

## E8740A-010 Radar RF, SA

### Cost effective radar RF test tool

- 3 Hz to 26.5 GHz, 60 GHz to 90 GHz
- RF analysis

## E8740A-020, 030 Basic SA

### Radar signal quality test

- 60 GHz to 90 GHz
- 2.5 GHz BW (020)
- > 5 GHz BW (030)
- FMCW quality analysis

## E8740A-040, 050 Advanced SA

### Benchmark for demanding applications

- 3Hz to 26.5 GHz, 60 GHz to 90 GHz
- 2.5 GHz BW (040)
- > 5 GHz BW (050)
- FMCW quality analysis
- Spurious emissions

## E8740A-060 Performance SA

### Wide-open performance

- 3 Hz to 110 GHz
- > 5 GHz BW for
- DANL -174 dBm
- 2.4 mm, 1 mm input
- FMCW quality analysis
- Spurious emissions
- SEM and ACLR

## X-Series Applications

Ready-to-use RF measurements

### 89600 VSA Software

Comprehensive demodulation & vector signal analysis

### KS83200A/KS83ST0A Automation platform for automotive Radar

Basic and ETSI standards-compliant test cases

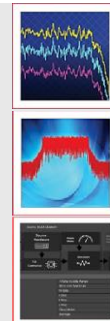

# Automotive Radar Signal generation solutions

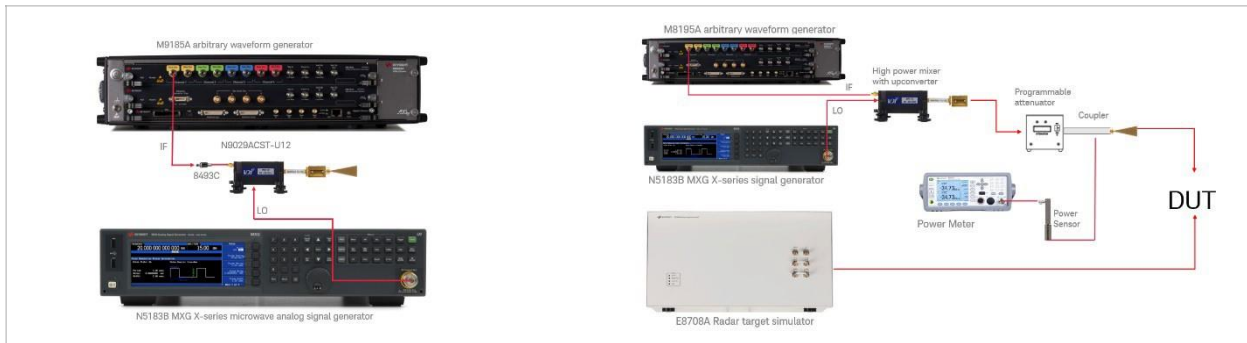

## E8740A-070 Performance SG

### Wide-open performance

- DC to 25 GHz, 60 GHz to 90 GHz
- > 5 GHz 3 dB BW
- FM, PM, FMCW, pulse sequence, MFSK, customer OFDM
- Linear FMCW multi-targets, automotive radar 3D scan and walking pedestrian scenarios with micro Doppler effect using SystemVue

## E8740A-080 Interference Test

### Standardized and custom test cases

- DC to 25 GHz, 60 GHz to 90 GHz
- > 5 GHz 3 dB BW
- mmW automatic power control loop
- FMCW up/down/tri, Custom Chirp signal, MFSK, CW signal capabilities

## Signal Studio

N7608C FMCW/MFSK signal creation

**KS83200A/KS83ST0A/KS83RX0A Automation Platform for Automotive Radar**  
Basic, ETSI standards-compliant test cases and Rx/Interference



## E8740A-010 Radar RF Signal Analysis

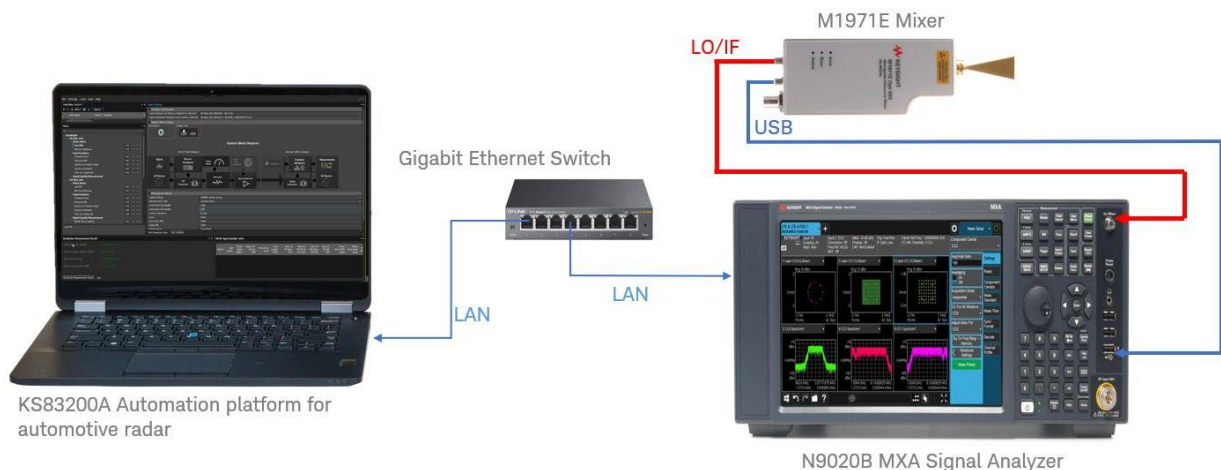

The E8740A-010 solution provides cost-effective testing for automotive radar RF, from 3 Hz to 26.5 GHz and 60 GHz to 90 GHz including RF analysis and access to test standards with KS8320A.

This is the most basic of signal analysis package from Keysight for automotive radar testing. This option for the Keysight automotive radar tools can do in-band RF measurements for transmitter systems. If you need higher frequency performance or wider bandwidth please consider E8740A-020, E8740A-030, E8740A-040, E8740A-050 or E8740A-060.

### Solution Specifications and Characteristics

Signal analysis	RF analysis & test
Frequency range	3 Hz to 26.5 GHz, 60 GHz to 90 GHz
DANL/Noise floor	-165 dBm/Hz at 1 GHz -139 dBm/Hz at 77 GHz, typical
Total absolute amplitude accuracy	3 Hz to 26.5 GHz, $\pm (0.33 \text{ dB} + \text{frequency response})$ (10 dB attenuation, 20 to 30 °C, 1 Hz $\leq$ RBW $\leq$ 1 MHz, input signal -10 to -50 dBm, all settings autocoupled except Auto Swp Time = Accy, any reference level, any scale, $\sigma$ = nominal standard deviation)  60 GHz to 90 GHz, $\pm 2.2 \text{ dB}$ , Calibration accuracy <sup>1</sup> (nominal)
RF input limit : Compr./damage (dBm)	30 dBm upto 26.5 GHz 20 dBm at 60 GHz to 90 GHz
Connector type	N-type connector and WR12

<sup>1</sup> Calibration accuracy is the difference between the conversion loss factors measured and programmed into the M1971E/V/W at the factory and the actual conversion loss of the mixer when used with an X-Series signal analyzer and Option EXM. The values shown include test system uncertainty, interpolation error, and the effects of the difference between the X-Series environment and the factory calibration environment. The system amplitude accuracy is worse than the M1971E/V/W only calibration accuracy due to the SWR effects between the M1971E/V/W and the X-Series IF input, and due to gain accuracy at the IF input of the X-Series analyzer used.

## E8740A-020 Basic Radar Signal Analysis

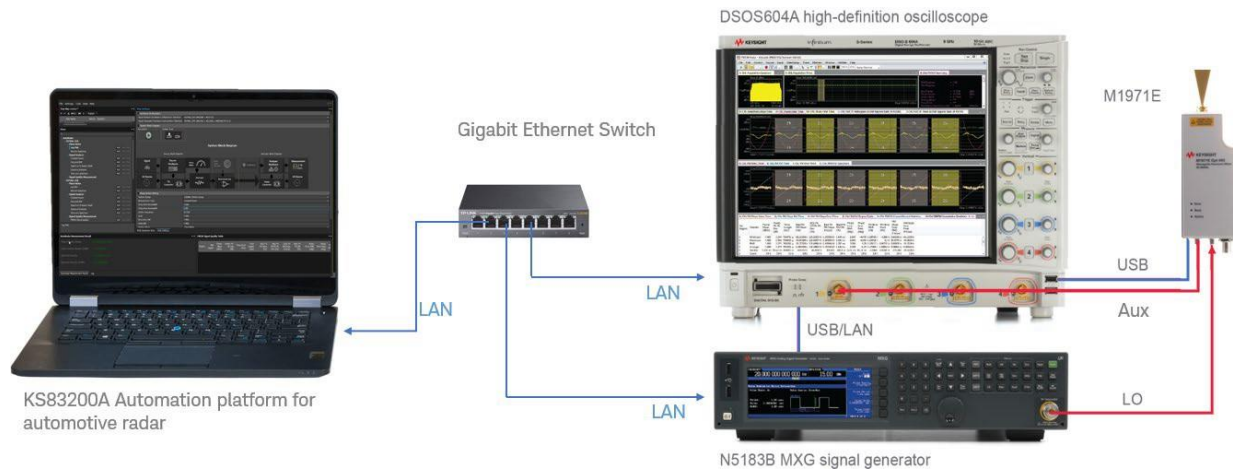

The E8740A-020 solution provides a testing configuration for automotive radar signal quality verification. Expand to simultaneous two channel analysis with two M1971E mixers set at the same frequency. Make RF power, frequency stability, modulation quality, RF and FMCW signal quality measurements. The E8740A-020 will provide in-band measurements for your radar transmitter systems.

If you need higher frequency performance or wider bandwidth please consider E8740A-030, E8740A-040, E8740A-050 or E8740A-060.

### Solution Specifications and Characteristics

Signal analysis	RF test (FFT) and FMCW signal quality
Frequency range	DC to 6 GHz, 60 GHz to 90 GHz
Demodulation bandwidth	2.5 GHz (3 dB BW) (using M1971E AUX path mode with DSO scope)
External digitizer resolution and ADC bit	10 bits up to 8 GHz (Min resolution: 0.781 mV)
DANL	-139 dBm/Hz at 76 – 81 GHz (with M1971E dual conversion mode)
Absolute amplitude accuracy	$\pm 1$ dB at 0 to 6 GHz (DSOS604A scope input) $\pm 2$ dB at 76 to 81 GHz (Typical with correction)
RF input limit : Compr./damage (dBm)	20 dBm at 60 GHz to 90 GHz 0 dBm P1dB
Connector type	WR12

## E8740A-030 Basic Plus Radar Signal Analysis

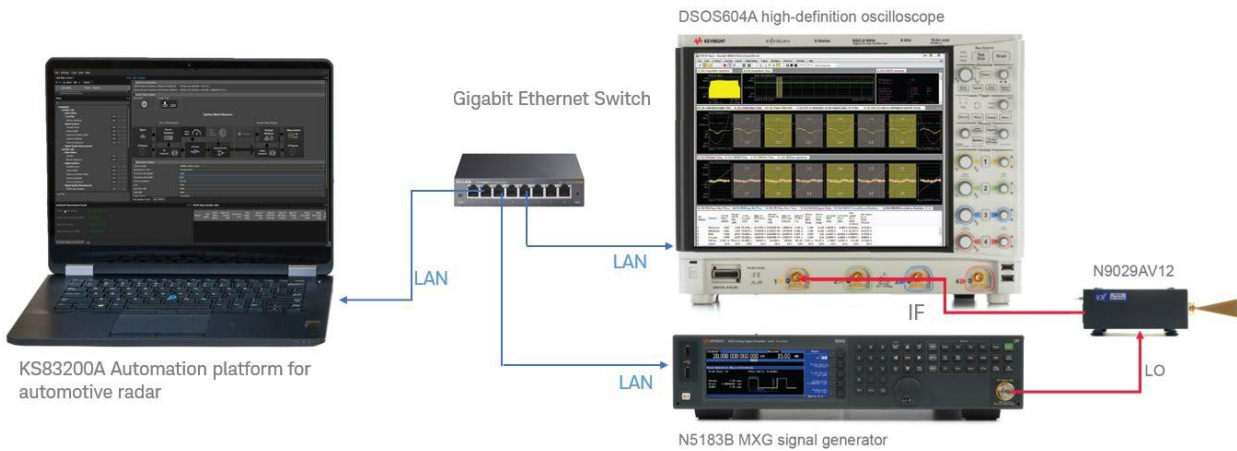

The E8740A-030 solution provides user interface and testing configuration for automotive radar signal quality verification. Covering frequencies DC to 6 GHz as well as higher banded 60-90 GHz and with 3.5 GHz bandwidth verify the accurate transmission of radar signals. Use for RF test with an FFT and FMCW signal quality including harmonic, spurious, and spectrum emissions, OBW, phase noise, analog/digital I/Q input, modulation quality, and linearity measurements. The E8740A-030 will help provide in-band measurements for your radar transmitter systems

If you need higher frequency performance or wider bandwidth please consider E8740A-040, E8740A-050 or E8740A-060.

### Solution Specifications and Characteristics

Signal analysis	RF test (FFT) and FMCW signal quality
Frequency range	DC to 6 GHz, 60 GHz to 90 GHz
Demodulation bandwidth	3.5 GHz (3 dB BW) 5 GHz with correction
External digitizer resolution and ADC bit	10 bits up to 8 GHz (Min. resolution: 0.781 mV)
DANL/Noise floor	-135 dBm/Hz at 76 – 81 GHz (DSOS604A with N9029AV12)
Absolute amplitude accuracy	$\pm 1$ dB at 0 to 6 GHz (DSOS604A scope input) $\pm 2$ dB at 76 to 81 GHz (Typical with correction)
RF input limit: Compr./damage (dBm)	-10 dBm / 0 dBm at 60 GHz to 90 GHz -10 dBm P1dB
Connector type	WR12



## E8740A-040 Advanced Radar Signal Analysis

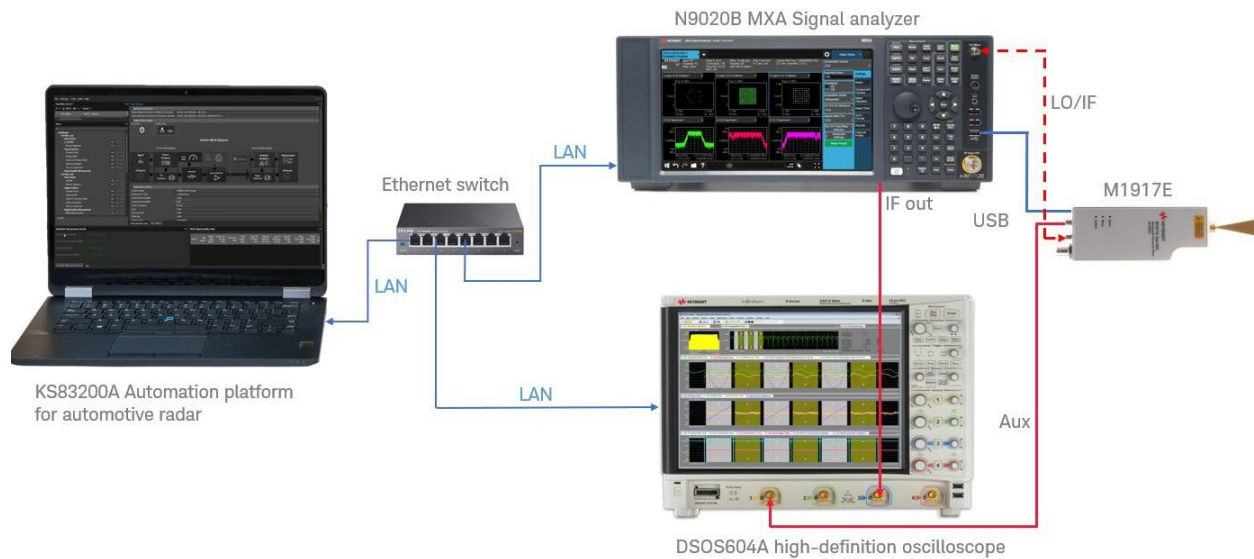

The E8740A-040 covers frequencies 3 Hz to 26.5 GHz as well as higher banded 60-90 GHz and with 2.5 GHz bandwidth verify the accurate transmission of radar signals for both 24 GHz and 77/79 GHz. Use it for RF test with an FFT and FMCW signal quality including harmonic, spurious, and spectrum emissions, phase noise, analog/digital I/Q input, modulation quality, linearity, as well as other measurements.

If you need higher frequency performance or wider bandwidth, please consider E8740A-050 or E8740A-060.

Solution Specifications and Characteristics		E8740A-040 Advanced SA
Signal analysis	RF test and FMCW signal quality	
Frequency range	3 Hz to 26.5 GHz, 60 GHz to 90 GHz	
Demodulation bandwidth	2.5 GHz (3 dB BW) using M1917E AUX path mode with DSO scope	
External digitizer resolution	10 bits up to 6 GHz (Min. resolution: 0.781 mV)	
DANL/Noise floor	N9020B (DANL) -166 dBm / Hz at 1 GHz -139 dBm/Hz at 76 GHz	DSOS604A (Noise floor) -126 dBm/Hz at 76 to 81 GHz
Absolute amplitude accuracy	3 Hz to 26.5 GHz, $\pm 0.33$ dB + frequency response with N9020B (10 dB attenuation, 20 to 30 °C, $1 \text{ Hz} \leq \text{RBW} \leq 1 \text{ MHz}$ , input signal -10 to -50 dBm, all settings autocoupled except Auto Swp Time = Accy, any reference level, any scale, $\sigma$ = nominal standard deviation) 60 GHz to 90 GHz, $\pm 2.2$ dB, Calibration accuracy <sup>2</sup> (nominal) with N9020B option EXM 76 GHz to 81 GHz, $\pm 2$ dB (typical with correction), using M1917E AUX path with scope	
RF input limit: Compr./damage (dBm)	30 dBm up to 26.5 GHz, 20 dBm at 60 GHz to 90 GHz	
Connector type	N-type connector and WR12	
Resolution bandwidth extended (optional)	8 MHz standard, up to 133 MHz (N9020B)	

<sup>2</sup> Calibration accuracy is the difference between the conversion loss factors measured and programmed into the M1917E/V/W at the factory and the actual conversion loss of the mixer when used with an X-Series signal analyzer and Option EXM. The values shown include test system uncertainty, interpolation error, and the effects of the difference between the X-Series environment and the factory calibration environment. The system amplitude accuracy is worse than the M1917E/V/W only calibration accuracy due to the SWR effects between the M1917E/V/W and the X-Series IF input, and due to gain accuracy at the IF input of the X-Series analyzer used.

## E8740A-050 Advanced Plus Radar Signal Analysis

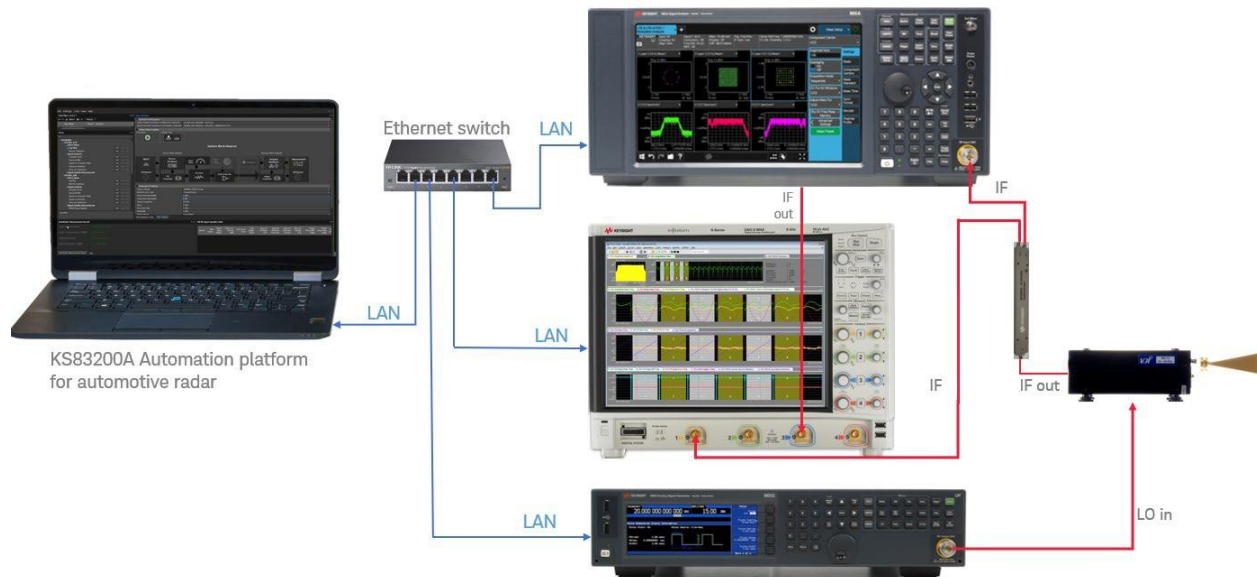

The E8740A-050 solution provides the frequency and bandwidth to accurately test both short range and long-range radar. Capture, analyze and test RF signals with an FFT or use it for FMCW signal quality including spectrum emissions, phase noise, modulation quality, linearity, and more measurements. If you need a wider frequency sweep or wider bandwidth, please consider our most advanced signal analysis option with the E8740A-060.

### Solution Specifications and Characteristics

Signal analysis	RF test and FMCW signal quality	
Frequency range	3 Hz to 26.5 GHz, 60 GHz to 90 GHz	
Demodulation bandwidth	3.5 GHz (3 dB BW), 5 GHz with correction	
External digitizer resolution	10 bits up to 8 GHz (Min resolution: 0.781 mV)	
DANL/Noise floor	N9020B	DSOS604A
	-166 dBm/Hz at 1 GHz -140 dBm/Hz at 76 GHz	-135 dBm/Hz at 76 GHz
Absolute amplitude accuracy	3Hz to 26.5GHz, $\pm (0.33 \text{ dB} + \text{frequency response})$ with N9020B (10 dB attenuation, 20 to 30 °C, $1 \text{ Hz} \leq \text{RBW} \leq 1 \text{ MHz}$ , input signal -10 to -50 dBm, all settings autocoupled except Auto Swp Time = Accy, any reference level, any scale, $\sigma = \text{nominal standard deviation}$ ) 60GHz to 90 GHz, $\pm 2.0 \text{ dB}$ (typical with system correction) with N9020B $\pm 2.0 \text{ dB}$ at 76 GHz to 81 GHz (typical with system correction) with DSO604A	
RF input limit: Compr/damage (dBm)	30 dBm up to 26.5 GHz, -10 dBm / 0 dBm at 60GHz to 90GHz	
Connector type	N-type connector and WR12	

## E8740A-060 Performance Radar Signal Analysis

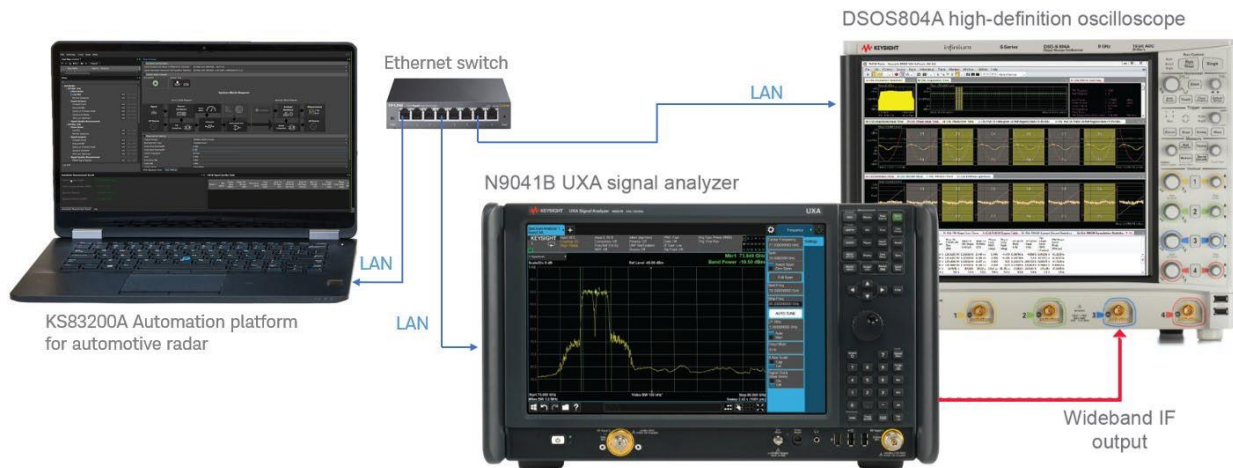

The E8740A-060 Performance Radar Signal Analysis Solution provides a wide field of view for the most advanced automotive radar performance test and analysis. Measurements include RF power, harmonic, spurious, and spectrum emissions, OBW, frequency stability as well as modulation quality, phase noise and noise figure and out-of-band SEM and ACLR.

If you are interested in radar signal analysis and do not need the ultra-performance available with the N9041B UXA consider the other configurations; E8740A-010, E8740A-020, E8740A-030, E8740A-040, or E8740A-050.

### Solution Specifications and Characteristics

Signal analysis	RF test and FMCW signal quality
Frequency range	3 Hz to 110 GHz
Demodulation bandwidth	> 5 GHz
External digitizer resolution	10 bits up to 8 GHz (Min resolution: 0.781 mV)
DANL/Noise floor	-174 dBm 20 MHz to 3.6 GHz (Preamp On with Opt NF2), -149 dBm 55 GHz to 70 GHz -144 dBm 70 GHz to 82 GHz
Absolute amplitude accuracy	$\pm 0.19$ dB at 0.05 to 3.6 GHz Input 1 <i>10 dB input attenuation, <math>1 \text{ Hz} \leq \text{RBW} \leq 1 \text{ MHz}</math>, input signal -10 to -50 dBm, all settings auto-coupled except Auto Swp Time = Accy, any reference level, any scale</i> $\pm 2.5$ dB at 75 – 110 GHz Input 2 (Nominal)
Maximum safe input level	+30 dBm (1W), Input 1 frequency $\leq 50$ GHz +5 dBm (0.003W), Input 2 frequency > 65 GHz, Attenuator 2 setting = 0 dB
Connector type	Dual input rugged 2.4 mm and 1 mm connector
Resolution bandwidth extended (opt)	8 MHz standard, up to 212 MHz (N9041B)

## E8740A-070 Performance Radar Signal Generation

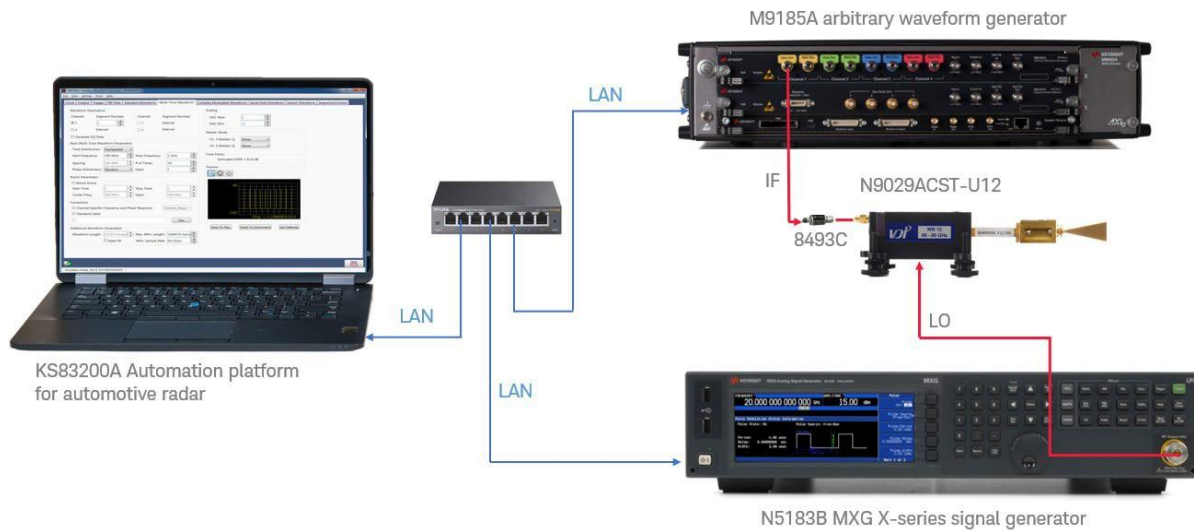

The E8740A-070 solution provides wide-field signals with wide modulation bandwidth (> 4 GHz) offering flexible modulation formats to generate ideal reference signals as well as interference, clutter, or jamming signals for a complete and robust receiver test solution. System design is possible with linear FMCW multi-targets, automotive radar 3D scan and walking pedestrian scenarios with micro Doppler effect using W1908 SystemVue.

### Solution Specifications and Characteristics

Frequency range	DC to 25 GHz, 60 GHz to 90 GHz
Signal bandwidth for IF/RF	IF/RF up to 25 GHz
3 dB bandwidth for mmW	5 GHz for FMCW at 79 GHz Fc (with correction)
P1dB	-14.6 dBm at 76 GHz -13.5 dBm at 79 GHz
Amplitude flatness (at SMA connector, <sup>3</sup> compensated for $\sin(x)/x$ )	$\pm 2$ dB (typ), $f_{out}$ = DC to 10 GHz $+2$ dB, $-3$ dB (typ), $f_{out}$ = 10 to 25 GHz (typ)
Amplitude resolution	200 $\mu$ V (normal)
DAC resolution	8-bit
AWG sample rate	13.44 GSa/s to 65 GSa/s
Sample memory (internal/extended)	1 MSa / 16 GSa
Frequency switching time	505 $\mu$ s / 38 ps (opt FSW)
MIMO and beam forming	Expandable to 16 synchronized channels
mmW modulation signals	FM, PM, FMCW, pulse sequence, MFSK, custom OFDM

<sup>3</sup> Measured at Data Out.

## E8740A-080 Interference Test Solution

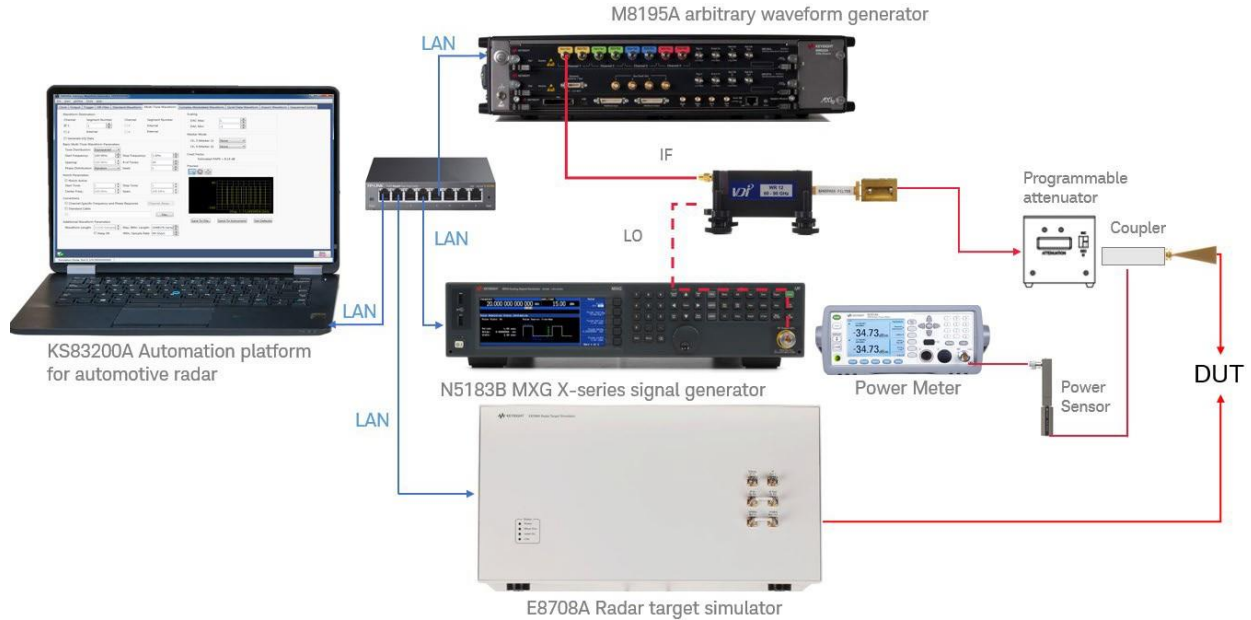

The E8740A-080 Interference test solution provides a way to generate specific or custom interference tests enabling a way to stress your radar module. Including wide-field signals, wide modulation bandwidth (> 4 GHz) and flexible modulation formats. Keysight's M8195A arbitrary waveform generator (AWG) can generate extremely wide modulated bandwidth radar signals thereby making it possible to discern targets close together. The instantaneous frequency hopping and overlapping pulses at different frequencies make realistic simulation of multiple emitters that are transmitting simultaneously. Coupling that with the effective simulation of a target in Keysight's E8708A radar target simulator (RTS) you can mimic the real-world interference that will undoubtedly occur and is required for regional standards in today's radar modules.

## E8740A-090 Conformance Spurious Emission Test Solution

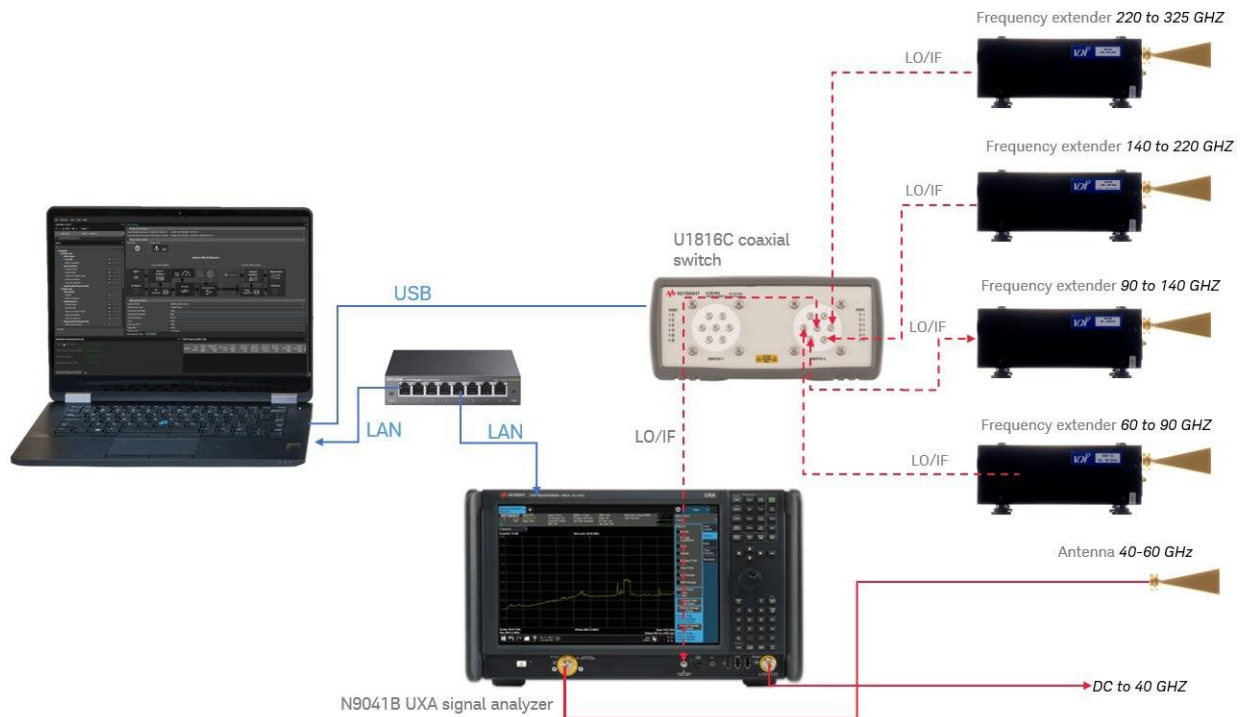

The E8740A-090 solution provides all of the hardware components for you to analyze signals from 0 - 330 GHz for emission testing. Tests include; operating frequency range, mean power, peak power, unwanted emissions in the out-of-band domain as well as unwanted emissions in the spurious domain for both transmitter and receiver conformance.

Each frequency band can be purchased individually. A signal analyzer N9041B is required to see the results of the emission testing. You can purchase an N9041B through the E8740A-060, stand alone or use a unit already owned. Please see configuration guide for more details.

Model	Description
E8740A-090	Conformance and Spurious Emission test solution covering frequencies from 0-330 GHz
E8740A-091	Conformance and emission test 40-60 GHz
E8740A-092	Conformance and emission test 60-90 GHz
E8740A-093	Conformance and emission test 90-140 GHz
E8740A-094	Conformance and emission test 140-220 GHz
E8740A-095	Conformance and emission test 220-325 GHz

## Hardware – Instruments

---

### N9041B UXA signal analyzer

[www.keysight.com/find/n9041b](http://www.keysight.com/find/n9041b)

Developing off-the-shelf tools for extremely high frequencies requires Keysight's proven blend of measurement science and millimeter-wave expertise. The N9041B UXA X-Series signal analyzer exemplifies the company's unique expertise, and the development team focused on meeting three key challenges in mmWave signal analysis: sensitivity, frequency range and analysis bandwidth.



### N9020B MXA signal analyzer

[www.keysight.com/find/n9020b](http://www.keysight.com/find/n9020b)

The Keysight N9020B MXA is the optimum choice as you take new-generation wireless devices to market. It has the flexibility to quickly adapt to evolving test requirements, today and tomorrow.



### DSOS604A/DSOS804A high-definition oscilloscope

[www.keysight.com/find/infiniium](http://www.keysight.com/find/infiniium)

Infiniium S-Series oscilloscopes incorporate innovative technology designed to deliver superior measurements.

Our new 10-bit ADC and low-noise front-end technology work together to provide up to 8 GHz performance with the industry's best signal integrity. We put these in an advanced frame with a solid-state drive for fast boot-up, capacitive 15" display for easy touch capability, and a high-powered motherboard for fast processing. It's all compatible with a myriad of probes and Infiniium applications.

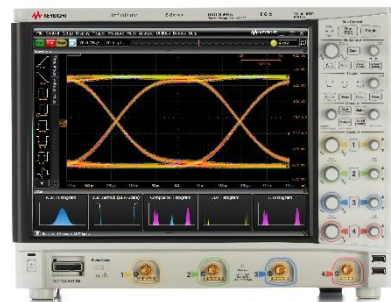

---

## N9029AV12

[http://www.keysight.com/find/sa\\_mmwave](http://www.keysight.com/find/sa_mmwave)

The Keysight N9029AV12 millimeter-wave signal analyzer frequency extension module is one of the mixer/amplifier/multiplier chain series (WRxx SAX Series) from VDI Inc. that has been designed to work directly with the N9030A PXA, N9020A MXA or N9010A EXA X-Series signal analyzers. The module provides high sensitivity millimeter measurements for the WR12 waveguide band covering 60 to 90 GHz. The N9029AV12 extends the high-performance attributes of the X-Series signal analyzer into millimeter frequencies.



For more millimeter test equipment solutions, please contact Virginia Diodes, Inc. (VDI) at [www.vadiodes.com](http://www.vadiodes.com).

---

## N9029ACST-U12

[http://www.keysight.com/find/sa\\_mmwave](http://www.keysight.com/find/sa_mmwave)

The Keysight N9029ACST- U12, D12 Compact Converter (CCU, CCD) modules are manufactured by Virginia Diodes, Inc. (VDI).

The CCU module provides high performance broadband frequency upconversion and the CCD provides the down-conversion. The modules can be used with microwave signal generators and spectrum analyzers to extend the frequency range. These modules achieve low conversion loss and excellent noise figure. Refer to the VDI User's Guide included on the USB drive.



For more millimeter test equipment solutions, please contact Virginia Diodes, Inc. (VDI) at [www.vadiodes.com](http://www.vadiodes.com).

---

## M1971E waveguide harmonic mixers (smart mixers)

[www.keysight.com/find/smartmixers](http://www.keysight.com/find/smartmixers)

The Keysight M1971E 55/60 to 90 GHz waveguide harmonic mixer provides a complete solution for wideband millimeter-wave signal analysis of more than 2.5 GHz with X-Series signal analyzers. Smart features are embedded to help you to greatly simplify your overall test setup and improve the DANL and TOI of your test system. Go smart with harmonic mixing for your millimeter-wave applications.





---

## N5183B MXG X-series microwave analog signal generator

[www.keysight.com/find/mxg](http://www.keysight.com/find/mxg)

The Keysight N5183B MXG is the pure and precise alternative to the analog PSG, with advantages in size and speed. It delivers the performance you need—spectral purity, output power, and more—to perform module- and system-level testing.



---

## M8195A 65 GSa/s Arbitrary waveform generator

[www.keysight.com/find/m8195a](http://www.keysight.com/find/m8195a)

The Keysight M8195A arbitrary waveform generator (AWG) provides up to 65 GSa/s, 25 GHz bandwidth, 8 bits vertical resolution, and up to 4 channels in a 1-slot AXIe module, simultaneously. As devices and interfaces become faster and more complex, the M8195A AWG gives you the versatility to create the signals you need for digital applications, advanced research, wideband radar, satcom, and optical communications.



---

## E8708A Radar Target Simulator

[www.keysight.com/find/E8708A](http://www.keysight.com/find/E8708A)

The E8708A radar target simulator is designed for simulating targets for radar units in the 76 GHz to 77 GHz range. Accurately and repeatedly simulate targets to test radar units from 4 m to 300 m. The E8708A is available in either dual-horn - Tx and Rx, or a single horn configuration with built-in circulator



## Software

For immediate access to common standards, test cases, instrument configurations, and calibration data you will want to take advantage of Keysight's automation platform for automotive Radar – KS83200A software. The Keysight KS83200A, KS83ST0A and KS83RX0A automation software automotive radar are a suite of standards-compliant routines for testing and validation of radar transmitters and receivers. Its automated routines simplify programming, customization and testing, and timely updates keep it current with the latest standards. Five essential capabilities accelerate test development:

- Easy-to-configure user interface for test setup and sequencing
- Libraries of test routines for specific automotive radars
- Pre-defined test setups for ETSI standards
- Functional blocks for testing of transmitters & receivers
- Customizable test scenarios that simplify creation of unique test cases
- Links to the necessary high-frequency instruments, including calibration information

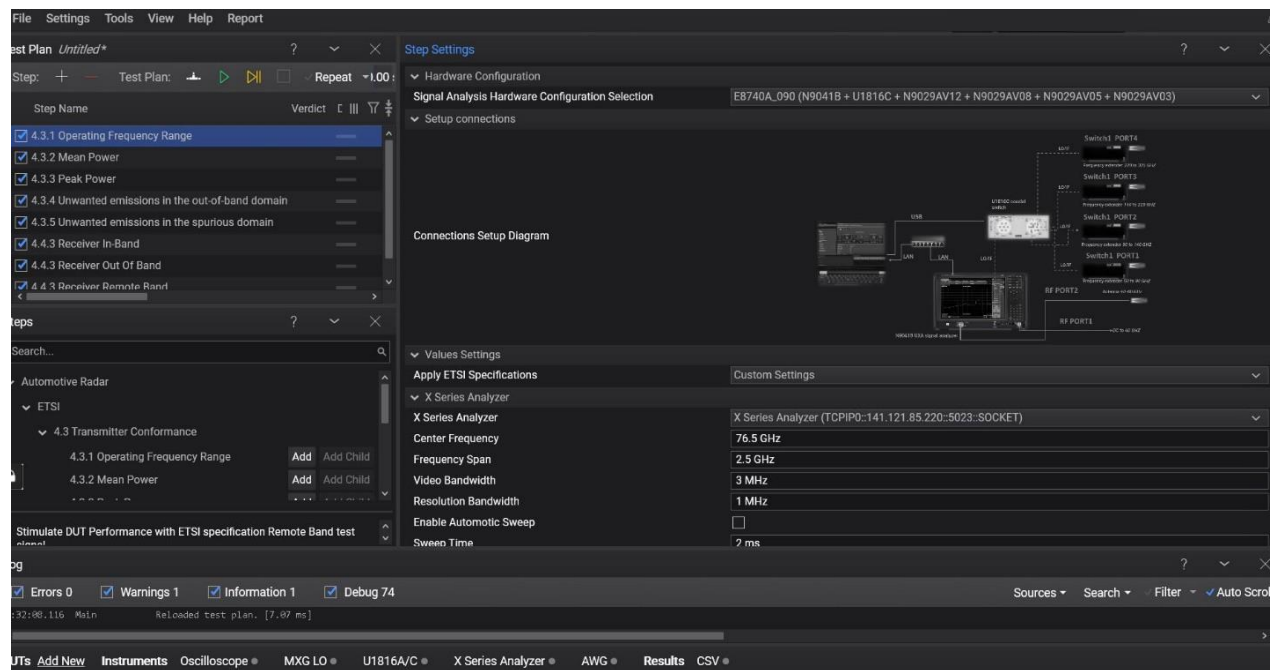

The platform includes calibration routines that account for the instruments and fixtures in each specific test setups. Minimizing loss is especially important when working with mmWave instruments and signals as even the slightest variation can cause erroneous go/no-go results.

## KS8400A Test Automation on PathWave(TAP) Developer's suite

The Keysight KS83200A, KS83ST0A and KS83RX0A automation software for automotive radar is built as a plugin to the Keysight KS8400A TAP. The Keysight TAP software provides powerful, flexible and extensible test sequence and test plan creation with additional capabilities that optimize your test software development and overall performance. TAP is a modern Microsoft .NET-based application that can be used stand-alone or in combination with higher level test executive software environments.

- **Fast execution and test flow analysis.** TAP's core engine is designed for speed-optimized execution. Additional tools provide visualization, analysis and insights to maximize your overall test flow performance.
- **User interfaces.** TAP provides a graphical user interface (GUI) so that both beginning and experienced programmers can quickly construct test plans consisting of multiple test steps. Flow operations are supported, along with parallel testing.
- **Modular "plugin" software architecture.** Test steps, instrument/DUT (device under test) interfaces, and result storage are architected as plugins. You can build unique test solutions quickly using the provided plugins. Or, for additional flexibility, adapt and modify the provided plugins for your applications. You can also create new plugins to optimize your application.
- **Microsoft .NET test step development.** TAP makes it easy to implement new test steps and plugins leveraging Microsoft Visual Studio and .NET.

More information [www.keysight.com/find/pathwavetest](http://www.keysight.com/find/pathwavetest)

The screenshot displays the Keysight Test Automation software interface. The main window is titled 'Test Plan' and shows a test plan with two steps: 'Charge' (3.58 s) and 'Discharge' (4.42 s). The 'Step Settings' panel on the right shows configuration for the 'Discharge' step, including 'Power Analyzer' (PSU), 'Measurements' (Voltage), 'Measure Interval' (0.2 s), 'Cell' (Target Voltage Margin: 0.8 V), 'Power Supply' (Discharge Current: 5 A, Output: 2.2 V), and 'Output' (Discharge Time: 4.4173227 s). The 'Log Panel' at the bottom shows a detailed log of test steps and their results, including voltage measurements and discharge times. Below the screenshot, three boxes labeled 'DUT Plugins', 'Hardware Plugins', and 'Result Storage' are shown with arrows pointing to the corresponding components in the software interface.

TAP's Core Sequencing Engine and GUI showing a test plan consisting of multiple test steps, settings for each test step, and a log panel with helpful status information to aid troubleshooting, hardware interfaces, databases and test plan optimization.

## FMCW Radar Analysis

The Keysight 89600 VSA software is used within the E8740A when an oscilloscope is in the configuration for a comprehensive signal demodulation, vector signal analysis and time domain analysis. Option BHP for FMCW radar analysis helps R&D and design verification test engineers make automated modulation quality measurements on multi-chirp linear FM signals according to the evolving requirements for radar sensor performance and detection techniques in the automotive industry.

The 89601B-BHP FMCW option provides signal synchronization, quick access to multiple FMCW modulation domain result traces, metrics, statistics, histograms and trend lines.

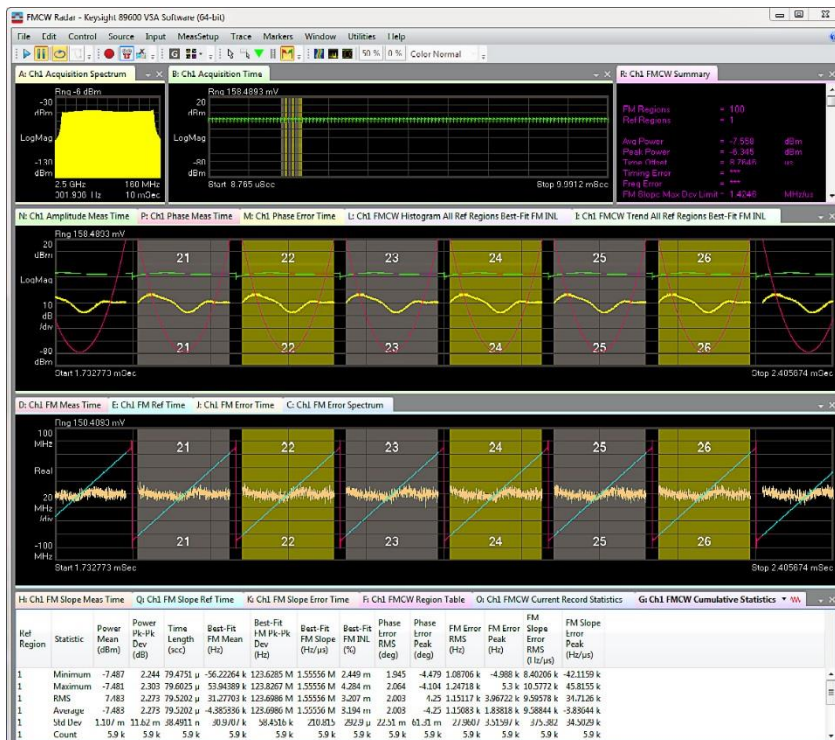

View spectrum and time domain results on multi-chirp FM signals. In the image pictured here highlighting six selected FM regions (number 21 through 26) in synchronized time domain traces. The FMCW cumulative statistic table below provides accumulated results over all detected regions.

89601B-BHP as well as the standard 89601B-200 the basic VSA software are required for all configurations within the E8740A that utilize an oscilloscope. There are multiple licensing configurations available. VSA software supports three types of licenses: a transportable license (89601B), a floating license (89601BN) and USB portable license (89601BK).

Visit <http://www.keysight.com/find/VSA> for more information.

## Custom automotive radar signal creation

The E8740A automotive radar signal analysis and generation solution Keysight N7608 Signal Studio to enable custom signal creation.

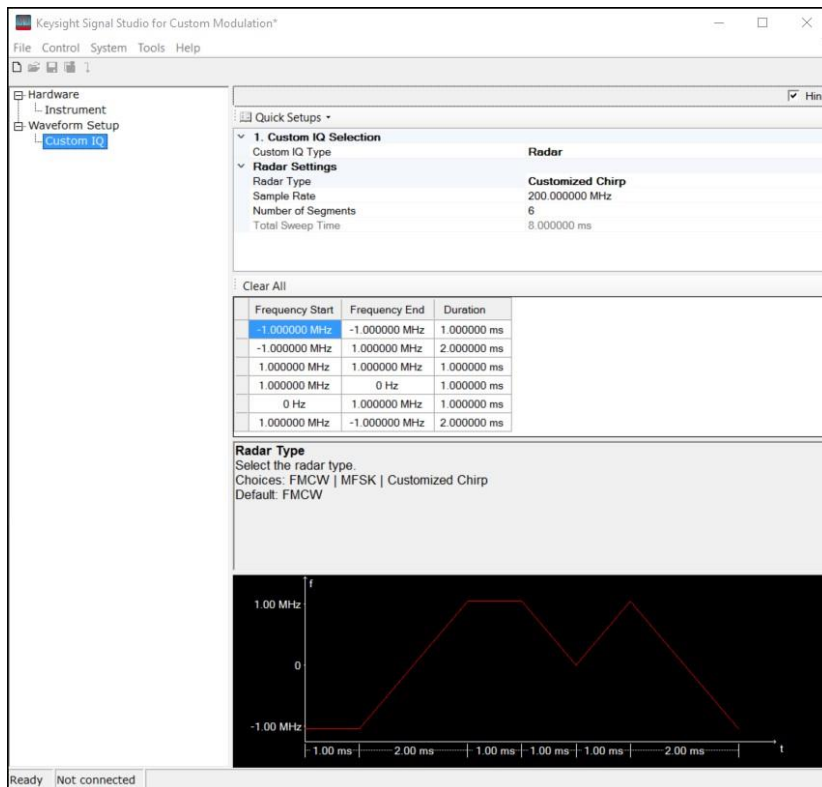

Custom waveforms with a wide range of modulation schemes can be imported into the AWG with the N7608APPC Signal Studio Software.

## Configure custom signals with Signal Studio

Signal Studio for custom modulation can be used to generate custom test signals for early testing of receiver system and component hardware. Pair with 89600 VSA software or X-Series measurement application software with Keysight signal analyzers and oscilloscopes to evaluate receiver performance at various stages of the receiver chain (RF, IF, and IQ).

N7608 is required for all configurations within E8740A that test a receiver 070 and 080. There are multiple licensing configurations available. Signal Studio Pro for Custom Modulation supports three types of licenses: a PC-based license (N7608APPC), a waveform playback license (N7608EMBC) and RAW IQ export license (N7608RAWC). Visit [www.keysight.com/find/ss-custom](http://www.keysight.com/find/ss-custom) for more information.

## Hardware Bundles

There are different configurations available from basic transmission testing through advanced signal analysis. For more configuration options, please refer to the E8740A configuration guide, literature part number 5992-2630EN [www.keysight.com/find/E8740A](http://www.keysight.com/find/E8740A)

Model	Description
E8740A-010	Radar RF signal analysis with N9020B, M1971E and automation software KS83200A
E8740A-020	Basic radar signal analysis with DSOS604A, M1971E, N5138B, 89601B VSA software, and FMCW radar analysis assistant
E8740A-030	Basic+ radar signal analysis with DSOS604A, N9029AV12, N5138B, 89601B VSA software, and FMCW radar analysis assistant
E8740A-040	Advanced radar signal analysis with N9020B, DSOS604A, M1971E, and automation software KS83200A
E8740A-050	Advanced Plus radar signal analysis with N9020B, DSOS604A, N9029AV12, N5183B, and automation software KS83200A
E8740A-060	Performance radar signal analysis with N9041B, DSOS804A, and automation software KS83200A
E8740A-070	Performance radar signal generation with M8195A, N5183B, N9029ACST, and automation software KS83RX0A
E8740A-080	Receiver and Interference test solution M8195A, N5183B, E8708A, and automation software KS83RX0A
E8740A-090	Conformance and Spurious Emission test solution covering frequencies from 0-330 GHz (Available only with E8740A-060)

## Software selections

Model	Description	Comments
89601B-200	Basic VSA and hardware connectivity	VSA software is used to visualize FMCW analysis. Both options are required in configurations that includes an oscilloscope.
89601B-BHP	FMCW radar analysis	
N7608A	Signal Studio	This is required for signal generation and is utilized in E8740A-070 and E8740A-080. There are a variety of licensing options available.
KS8400A	Test Automation Platform (TAP) Developer's System	This is required software to run the automotive radar plugins below
KS83200A	Automation platform for Automotive Radar – Basic	Applicable to all HW configurations; E8740A-010, E8740A-020, E8740A-030, E8740A-040, E8740A-050, E8740A-060, E8740A-070, E8740A-080, E8740A-090.
KS83RX0A	Automation platform for Automotive Radar – Receiver and Interference test	Applicable to E8740A-070, E8740A-080. KS83200A and N7608C are required.
KS83ST0A	Automation platform for Automotive Radar tests according to ETSI standards	Applicable to E8740A-010, E8740A-040, E8740A-050, E8740A-060, E8740A-070, E8740A-080. KS83200A required. Order E8740A-090 for spurious emission

## Compatibility matrix

Software component	E8740A 010	E8740A 020	E8740A 030	E8740A 040	E8740A 050	E8740A 060	E8740A 070	E8740A 080	E8740A 090
KS8400A TAP developer's system	✓	✓	✓	✓	✓	✓	✓	✓	✓
KS83200A Basic Automation platform for Automotive Radar	✓	✓	✓	✓	✓	✓	✓	✓	✓
89601 VSA (200 and BHP)		✓	✓	✓	✓	✓			
N7608A Signal Studio							✓	✓	
KS83RX0A Rx and Interference Automation platform for Automotive Radar							optional	optional	
KS83ST0A ETSI standards Automation platform for Automotive Radar	optional			optional	optional	optional	optional	optional	optional

## Definitions and acronyms

Acronyms	Definition	Comments
<b>ACLR</b>	Adjacent Channel Leakage Ratio	Ratio of the transmitted power to the power in the adjacent radio channel – verifies that a transmitter is performing within specified limits.
<b>CW</b>	Continuous Wave	A sin wave signal with no modulation.
<b>eRF</b>	enhanced RF	Measurement with swept mode using a spectrum or signal analyzer, typically to support emission testing
<b>FM</b>	Frequency Modulation	Encoding of information in a carrier wave by varying the frequency.
<b>FMCW</b>	Frequency Modulated Continuous Wave	Type of modulation currently specified for automotive radar transmissions
<b>I/Q</b>	IQ modulation type.	A signal can be defined by its I, in-phase, and Q, quadrature or “ $\pi/2$ radians offset” components.
<b>IF/RF</b>	Intermediate Frequency	Refers to the lower frequency modulated signal. RF is radio frequency and usually refers to the higher frequency carrier signal (See CW).
<b>MFSK</b>	Multiple Frequency Shift Keying	A signal modulation method where more than one frequency is employed
<b>OBW</b>	Occupied bandwidth	Specifications and measurement made with a signal or spectrum analyzer to test its ‘goodness’
<b>OFDM</b>	Orthogonal Frequency Division Multiplexing	Modulation schema that uses multiple carrier frequencies
<b>PM</b>	Pulse Modulation	Pulses are varied either by width or amplitude
<b>Rx</b>	Receiver	Typically referred to in testing the receiving capability of a module. The test (or tester) generates an ideal or known signal to check that the receiver is working
<b>SA</b>	Signal Analyzer	Instrument that measures the magnitude and phase of a signal, testing transmitter capabilities.
<b>SEM</b>	Spectrum emission mask	The SEM measurement is used to measure the excess emissions that would interfere to other channels or to other systems. The mask portion is “drawn” within the spectrum to give an indication as to when the signal crosses applicable thresholds. SEMs are defined by various standards bodies
<b>SG</b>	Signal Generator	Device that generates repeating or non-repeating signals, generally to test receiver capabilities
<b>SQ</b>	Signal Quality	A measurement to identify quality. Typically specifying how much the tested signal deviates from the ideal signal.
<b>Tx</b>	Transmitter	Typically referred to in testing the transmission capability of a module. The test (or tester) receives the signal and displays it for comparison to what has been sent.

Learn more at: [www.keysight.com](http://www.keysight.com)

For more information on Keysight Technologies’ products, applications or services, please contact your local Keysight office. The complete list is available at: [www.keysight.com/find/contactus](http://www.keysight.com/find/contactus)

